

19971017 122

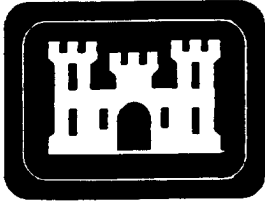

**ENERGY REPORT**

**ENERGY ENGINEERING  
ANALYSIS PROGRAM**

**ENERGY SAVINGS OPPORTUNITY SURVEY**

**FORT HUACHUCA, ARIZONA  
1994**

**VOLUME I**

**DTIC QUALITY INSPECTED 2**

**PREPARED FOR**

**DEPARTMENT OF THE ARMY  
SACRAMENTO DISTRICT, CORPS OF ENGINEERS  
SACRAMENTO, CALIFORNIA**

**PREPARED BY**

**KELLER & GANNON  
ENGINEERS • ARCHITECTS  
1453 MISSION STREET, SAN FRANCISCO, CA 94103**

**CONTRACT NO. DACA05-C-92-0155**

**EEAP Energy Savings Opportunity Survey  
Fort Huachuca, Arizona**

**Prefinal Submittal  
Instructions for Inserting Corrections  
Into Interim Submittal Documents**

<i>Remove and discard the following pages:</i>		<i>Insert the following pages:</i>	
<b>ENERGY REPORT - VOLUME I</b>			
Table of Contents	page i	Table of Contents	page i
List of Figures	page ii	List of Figures	page ii
List of Tables	page iii	List of Tables	page iii
SECTION 1.0	page 1-1	SECTION 1.0	pages 1-1 through 1-6 (Complete section)
SECTION 2.0	page 2-1	SECTION 2.0	page 2-1
SECTION 3.0	page 3-1 page 3-2 page 3-4	SECTION 3.0	page 3-1 page 3-2 page 3-4
SECTION 4.0	pages 4-1 through 4-13	SECTION 4.0	pages 4-1 through 4-14 (Complete section)
SECTION 5.0	page 5-2	SECTION 5.0	page 5-2
SECTION 6.0	pages 6-1 through 6-9	SECTION 6.0	pages 6-1 through 6-11 (Complete section)
APPENDIX A	No pages to discard	APPENDIX A	Add Minutes of Meeting dated 10 January 1995 and Attachments (1) through (4)
APPENDIX B	No pages to discard	APPENDIX B	Add pages B-9 and B-10
APPENDIX C	pages C-i through C-5	APPENDIX C	pages C-i through C-5 (Complete appendix)
APPENDIX D	pages D-i through D-8	APPENDIX D	pages D-i through D-8 (Complete appendix)
<b>APPENDICES - VOLUME II</b>			
APPENDIX E	pages E-i through E-25	APPENDIX E	pages E-i through E-27 (Complete appendix)
APPENDIX F	pages F-i through F-13	APPENDIX F	pages F-i through F-13 (Complete appendix)
APPENDIX H	pages H-i through H-75	APPENDIX H	ages H-i through H-75 (Complete appendix)
APPENDIX J	pages J-i through J-23	APPENDIX J	pages J-i through J-62 (Complete appendix)



**EEAP Energy Savings Opportunity Survey  
Fort Huachuca, Arizona**

<i>Remove and discard the following pages:</i>		<i>Insert the following pages:</i>	
APPENDIX K	No pages to discard	APPENDIX K	Insert pages K-199.1/K-199.2 following page K-199 Insert pages K-201.1/K.201.2 following page K-201





**DEPARTMENT OF THE ARMY**  
CONSTRUCTION ENGINEERING RESEARCH LABORATORIES, CORPS OF ENGINEERS  
P.O. BOX 9005  
CHAMPAIGN, ILLINOIS 61826-9005

REPLY TO  
ATTENTION OF: TR-I Library

17 Sep 1997

Based on SOW, these Energy Studies are unclassified/unlimited.  
Distribution A. Approved for public release.

  
Marie Wakefield,  
Librarian Engineering

## Table of Contents

- 1.0 Executive Summary
  - 1.1 Introduction
  - 1.2 Energy Conservation Projects
  - 1.3 Cogeneration Feasibility
  - 1.4 Harmonic Distortion Survey
- 2.0 Introduction
  - 2.1 Purpose
  - 2.2 Scope
  - 2.3 Methodology
- 3.0 Description of Installation
  - 3.1 Location, Size and Climate
  - 3.2 Electrical Power and Natural Gas Utilities
  - 3.3 Central Heating/Cooling Plants
- 4.0 Energy Conservation Retrofit Evaluations
  - 4.1 Life Cycle Cost Analysis Assumptions
  - 4.2 Construction Cost Estimate Methodology
  - 4.3 Utility Rebate Programs
  - 4.4 Energy Conservation Opportunities Studied
  - 4.5 Recommended Energy Conservation Projects
- 5.0 Harmonic Distortion Survey
  - 5.1 Description of the Problem
  - 5.2 Methodology and Data Summary
  - 5.3 Evaluation and Recommendations
- 6.0 Cogeneration Feasibility Evaluations
  - 6.1 Natural Gas Piping Capacity
  - 6.2 Turbine-Generator Facilities to Serve Central Heating/Cooling Plants
  - 6.3 Engine-Generator Facilities to Serve Central Heating/Cooling Plants
  - 6.4 Turbine-Generator Facilities to Serve Fort Huachuca and the City of Sierra Vista
- APPENDIX
  - A Scope of Work and Minutes of Project Meetings
  - B Utility Rate and Rebate Schedules
  - C Motor Survey Data and Retrofit Calculations
  - D Natural Gas Cooling Retrofit Calculations
  - E Building Envelope Retrofit Calculations
  - F HVAC Controls Retrofit Calculations
  - G Lighting Data and Energy Calculations
  - H Lighting Retrofit Calculations
  - I Harmonic Distortion Monitoring Data
  - J Backup Data to Cogeneration Analyses
  - K Carrier HAP Program Data



### List of Figures

Figure 3-1	Fort Huachuca Location Map . . . . .	3-3
Figure 3-2	Fort Huachuca Historical Electrical Demand, March 1993 to March 1994: Maximum Daily kW . . . . .	3-4
Figure 3-3	Fort Huachuca Historical Electrical Demand for 1984 to 1994: Maximum Monthly kW . . . . .	3-5
Figure 3-4	Fort Huachuca Historical Power Factor for 1984 to 1994: Monthly Average Power Factor in Percent . . . . .	3-6
Figure 6-1	Combined Cycle Cogeneration, PURPA Qualifying Facility Flow Diagram . . . . .	6-7
Figure 6-2	Combined Cycle Exempt Wholesale Generation Flow Diagram . . . . .	6-7
Figure 6-3	Cogeneration Alternative 1C1: Ebullient Cooled Engine Generator with Heat Recovery and Single-Stage Absorption Chilling . . . . .	6-8
Figure 6-4	Cogeneration Alternative 1C2: Gas Engine Generator with Exhaust Heat Recovery and Two-Stage Absorption Chilling . . . . .	6-8
Figure 6-5	Cogeneration Alternative 1C3: Ebullient Cooled Engine Generator with Exhaust and Jacket Heat Recovery, One- and Two-Stage Absorption Chilling . . . . .	6-9



### List of Tables

Table 1-1	Project Group Summaries for Recommended ECOs . . . . .	1-3
Table 1-2	Summary of Life Cycle Cost Analyses for Central Heating/ Cooling Plant Cogenerative Alternatives . . . . .	1-5
Table 1-3	Summary of Life Cycle Cost Analyses for Power Generation Alternatives Serving Fort Huachuca and Sierra Vista . . . . .	1-6
Table 2-1	Potential ECO Evaluation List . . . . .	2-4
Table 4-1	Summary of Analysis Results for Recommended ECOs . . . . .	4-7
Table 4-2	Summary of Analysis Results for ECOs Not Recommended . . . . .	4-9
Table 4-3	Summary of Energy-Efficient Motor Retrofit Evaluations . . . . .	4-10
Table 4-4	Summary of Building Envelope Retrofit Evaluations . . . . .	4-11
Table 4-5	Summary of HVAC Controls Retrofit Evaluations . . . . .	4-12
Table 4-6	Summary of Lighting and Controls Retrofit Evaluations . . . . .	4-13
Table 5-1	Summary of Harmonic Distortion Monitoring Data . . . . .	5-4
Table 5-2	Comparison of Monitored Harmonics Levels with IEEE Guidelines . . . . .	5-5
Table 6-1	Summary of Life Cycle Cost Analyses of Cogeneration to Serve Central Heating/Cooling Plants . . . . .	6-10
Table 6-2	Summary of Life Cycle Cost Analyses of Power Generation to Serve Fort Huachuca and Sierra Vista . . . . .	6-11



## **1.0 Executive Summary**

### **1.1 Introduction**

This report summarizes all work performed for the Energy Engineering Analysis Program (EEAP) Energy Savings Opportunity Survey (ESOS) at Fort Huachuca, Arizona, authorized under Contract DACA05-92-C-0155 with the U.S. Army Corps of Engineers, Sacramento District, Sacramento, California.

The purpose of this study is to develop projects and actions that will reduce facilities energy consumption and operating costs at Fort Huachuca. Implementation of these projects will contribute to achieving the goal of the Army Facilities Energy Plan of a reduction in energy consumption per square foot of building floor area of 20 percent by FY2000 from FY1985 baseline levels.

The facility survey and evaluation effort was limited to 21 buildings and a specific set of energy conservation opportunities (ECOs) having a high likelihood of proving to be economically feasible. Also included were feasibility evaluations of cogeneration alternatives including (a) cogenerating alternatives serving the existing central heating/cooling plants, (b) a generating facility sized to serve the total electric power requirements of Fort Huachuca and (c) a generating facility sized to serve the total power requirements of both Fort Huachuca and the adjacent city of Sierra Vista. Both turbine generators and reciprocating-engine generators were evaluated for a cogeneration facility serving the two central heating/cooling plants.

Harmonic distortion sampling at four buildings containing significant computer loads or electronic fluorescent ballasts was also included in the study scope.

### **1.2 Energy Conservation Projects**

Successful ECOs were packaged into project groups containing similar trades in order to eliminate the extra charges associated with subcontractor services. A Work Request (EHSC Form 4283-1) was prepared for each project group. Each programming document included complete supporting data: retrofit descriptions, energy and cost savings calculations, construction cost estimates and life cycle cost analysis summaries. Data summaries for each of the project groups appear in Table 1-1.

Each of the following ECOs was found to be cost-effective in at least one of the buildings studied:

- Roof and wall insulation
- Low emissivity roof coating
- Replacing electric motor-driven chiller with gas engine-driven chiller
- Economizer and supply air temperature reset controls
- High-efficiency motor retrofits
- Lighting fixture and control retrofits



**EEAP Energy Savings Opportunity Survey  
Fort Huachuca, Arizona**

**1.3 Cogeneration Feasibility**

A number of cogeneration alternatives serving either one or both of the central heating/cooling plants and containing either gas turbine or gas-fired reciprocating engine prime movers were evaluated. A summary of life cycle cost analyses for these central heating/cooling plant cogeneration alternatives appears in Table 1-2. The recommended alternative, based on highest savings-to-investment ratio (SIR), is a cogeneration facility serving both central heating/cooling plants and containing ebullient-cooled gas-engine generators with single-stage absorption chilling and steam heat exchangers to provide chilled and hot water for building HVAC use.

A summary of life cycle cost analyses for power generation facilities sized to serve Fort Huachuca and the City of Sierra Vista appears in Table 1-3. Generation facilities of the sizes required to serve Fort Huachuca and Sierra Vista cannot be served from existing gas distribution on post or upstream from Southwest Gas Corporation's Fort Huachuca regulating station. Budget costs for installing gas supply piping from a point 4.5 miles from the potential generating facility site were included in the investment amount. However, an in-depth engineering analysis to determine the need for additional facilities must first be performed by Southwest Gas Corporation before the overall economic feasibility of a power generating plant serving Fort Huachuca and the City of Sierra Vista can be determined.

**1.4 Harmonic Distortion Survey**

Harmonic distortion monitoring conducted at a representative sample of four buildings revealed that all measured voltage distortion levels were within the 5 percent recommended by ANSI/IEEE Standard 519. Current distortion percentages measured during early May were generally higher than those recommended by Standard 519, but are expected to fall within the guidelines during peak summer electrical demand periods when linear motor loads increase dramatically.



EEAP Energy Savings Opportunity Survey  
Fort Huachuca, Arizona

Table 1-1. Project Group Summaries for Recommended ECOs

Building or ECO Number	Retrofit Description	Energy Savings		Gas (Million BTU/Yr)		Energy Cost Savings		O&M Savings		Investment (\$)	Payback (Years)	SIR
		Electric (kW)	Electric (kWH/Year)	Gas	Electric (\$/Year)	Gas (\$/Year)	Electric (\$/Year)	Gas (\$/Year)				
<b>Building Envelope Modifications</b>												
15544	Wall & Roof Insul + Low E Roof Coat	0.0	27,827	442	\$1,750	\$1,556	\$43,080	\$0	\$0	\$24,210	7.32	1.78
20200	Retrofit Roof Insulation	0.0	4,029	64	\$253	\$226	\$6,245	\$0	\$0	\$4,147	8.65	1.51
43083	Roof: Insulation & Low E	0.0	124,909	1,228	\$7,857	\$4,318	\$155,623	\$0	\$0	\$58,567	4.81	2.66
51005	Apply Low E Roof Coating	0.0	(14,401)	928	(\$906)	\$3,264	\$35,364	\$0	\$0	\$16,822	7.13	2.10
56301	Apply Low E Roof Coating	0.0	149,852	567	\$9,426	\$1,994	\$141,556	\$0	\$0	\$6,437	0.56	21.99
91114	Apply Low E Roof Coating	0.0	5,460	(16)	\$343	(\$57)	\$3,321	\$0	\$0	\$1,498	5.23	2.22
<b>Subtotal, Building Envelope Modifications</b>		<b>0.0</b>	<b>297,676</b>	<b>3,214</b>	<b>\$18,724</b>	<b>\$11,301</b>	<b>\$385,191</b>	<b>\$0</b>	<b>\$0</b>	<b>\$111,681</b>	<b>3.72</b>	<b>3.45</b>
<b>Gas Engine-Driven Chiller Retrofit</b>												
56301	Gas Engine-Driven Chiller - 72 Tons	67.0	267,690	(1,823)	\$21,508	(\$8,218)	\$142,078	(\$1,032)	\$0	\$122,512	9.99	1.06
<b>Building HVAC Control Modifications and High Efficiency Motor Retrofits</b>												
56301	Economizer Control & SA Reset @ OA Temp	0.0	382,501	28,726	\$1,577	\$1,443	\$39,403	\$0	\$0	\$16,548	5.48	2.38
15544	SA Fan HVAC Unit	1.2	10,783	0	\$679	\$0	\$10,235	\$0	\$80	\$1,356	2.00	7.55
43083	SA Fan AHU No. 1	0.2	2,068	0	\$130	\$0	\$1,963	\$0	\$46	\$476	3.66	4.12
43083	SA Fan AHU No. 2	0.2	2,068	0	\$130	\$0	\$1,963	\$0	\$46	\$476	3.66	4.12
56301	SA Fan, North HVAC Unit	0.3	2,246	0	\$141	\$0	\$2,132	\$0	\$56	\$578	4.09	3.69
56301	SA Fan, Central HVAC Unit	0.3	2,246	0	\$141	\$0	\$2,132	\$0	\$56	\$578	4.09	3.69
56301	SA Fan, South HVAC Unit	0.3	2,246	0	\$141	\$0	\$2,132	\$0	\$56	\$578	4.09	3.69
56301	CHW Circ. Pump 1	0.3	1,168	0	\$73	\$0	\$1,108	\$0	\$17	\$421	5.73	2.63
56301	CHW Circ. Pump 2	0.2	727	0	\$46	\$0	\$694	\$0	\$17	\$421	9.20	1.64
56301	Condenser Fan 1	0.2	661	0	\$46	\$0	\$694	\$0	\$46	\$476	10.35	1.46
56301	Condenser Fan 2	0.2	661	0	\$46	\$0	\$694	\$0	\$46	\$476	10.35	1.46
57305	CHW Circ. Pump 2	0.5	2,368	0	\$149	\$0	\$2,248	\$0	\$88	\$1,623	10.89	1.38
61701	Pool Circ. Pump	0.4	3,472	0	\$219	\$0	\$3,296	\$0	\$75	\$947	4.33	3.48
62704	SA Fan	0.6	4,974	0	\$313	\$0	\$4,721	\$0	\$87	\$1,091	3.48	4.33
62704	RA Fan	0.3	2,246	0	\$141	\$0	\$2,132	\$0	\$56	\$578	4.09	3.69
67601	AHU 1 SA Fan	0.5	887	0	\$95	\$0	\$1,438	\$0	\$58	\$766	8.03	1.88
67601	AHU 2 SA Fan	0.5	887	0	\$95	\$0	\$1,438	\$0	\$58	\$766	8.03	1.88
67601	AHU 3 SA Fan	0.5	887	0	\$95	\$0	\$1,438	\$0	\$58	\$766	8.03	1.88
67601	AHU 4 SA Fan	0.5	887	0	\$95	\$0	\$1,438	\$0	\$58	\$766	8.03	1.88
67601	AHU 5 SA Fan	0.5	887	0	\$95	\$0	\$1,438	\$0	\$58	\$766	8.03	1.88
67601	AHU 7 SA Fan	0.5	887	0	\$95	\$0	\$1,438	\$0	\$58	\$766	8.03	1.88
80505	SA Fan East	0.9	7,536	0	\$474	\$0	\$7,154	\$0	\$85	\$1,266	2.67	5.65
80505	SA Fan West	0.9	7,536	0	\$474	\$0	\$7,154	\$0	\$85	\$1,266	2.67	5.65

EEAP Energy Savings Opportunity Survey  
Fort Huachuca, Arizona

Table 1-1. Project Group Summaries for Recommended ECOs

Building or ECO Number	Retrofit Description	Energy Savings		Energy Cost Savings		O&M Savings (\$/Year)	Utility Rebate (\$)	Investment (\$)	Payback (Years)	SIR
		Electric (kW)	Electric (kWh/Year)	Gas (Million BTU/Yr)	Electric (\$/Year)					
80505	RA Fan East	10	3,226	0	\$203	\$0	\$56	\$578	2.85	5.30
80505	RA Fan West	10	3,226	0	\$203	\$0	\$56	\$578	2.85	5.30
80505	Fan Coil Unit, Rm 213	5	1,789	0	\$113	\$0	\$35	\$520	4.62	3.26
80505	HWP-1	7.5	1,459	0	\$92	\$0	\$46	\$476	5.19	2.91
80505	Fan Coil Unit, Rm 249	7.5	1,935	0	\$122	\$0	\$46	\$708	5.82	2.59
80505	CHWP-1	15	1,959	0	\$123	\$0	\$58	\$766	6.21	2.43
80505	CHWP-2	15	1,959	0	\$123	\$0	\$58	\$766	6.21	2.43
80505	VAVH2 West, Roof FCU	15	1,676	0	\$105	\$0	\$58	\$766	7.26	2.08
80505	VAVH2, Roof FCU	15	1,676	0	\$105	\$0	\$58	\$766	7.26	2.08
91114	HW Circ. Pump	5	1,439	0	\$91	\$0	\$17	\$421	4.65	3.24
<b>Subtotal, Building HVAC Control Modifications and High Efficiency Motor Retrofits</b>		<b>13.2</b>	<b>461,172</b>	<b>28,726</b>	<b>\$6,775</b>	<b>\$1,443</b>	<b>\$1,778</b>	<b>\$40,098</b>	<b>4.88</b>	<b>2.94</b>
<b>Lighting Fixture and Control Retrofits</b>										
Lights A	LED Exit Fixtures	108 EA	17,171	0	\$1,082	\$0	\$972	\$5,438	5.94	2.03
Lights B2	Ballasts/T8s 2xF30T12	124 EA	8,124	0	\$868	\$0	\$1,240	\$5,502	5.66	2.12
Lights D1	Ballasts/T8, 1xF40T12	120 EA	9,066	0	\$658	\$0	\$1,080	\$5,217	9.99	1.20
Lights D2	Ballasts/T8, 2xF40T12	1,401 EA	107,700	0	\$9,046	\$0	\$14,010	\$67,229	7.47	1.61
Lights D5	Delamp 4 to 3 T8s, Ballasts	671 EA	144,543	0	\$13,296	\$0	\$12,749	\$43,531	3.16	3.81
Lights E1	Ballasts 2 xF48T12HO	48 EA	5,491	0	\$468	\$0	\$192	\$2,107	4.50	2.67
Lights F1	Ballasts/T8, 4xF96T12	20 EA	1,872	0	\$193	\$0	\$200	\$1,822	11.35	1.06
Lights F2	Ballasts/T8, 4xF96T12	1 EA	166	0	\$18	\$0	\$20	\$182	11.73	1.03
Lights G1	DTT 13W CF-Downlights	2 EA	139	0	\$18	\$0	\$10	\$37	1.44	8.36
Lights G2	TRI 20W Compact Fluor.	24 EA	4,547	0	\$523	\$0	\$35	\$62	0.08	153.60
Lights G3	TT 7W Compact Fluor.	71 EA	4,488	0	\$519	\$0	\$225	\$1,166	1.52	7.87
Lights G4	DTT 13W CF-Ceiling	45 EA	3,786	0	\$446	\$0	\$230	\$876	1.48	8.12
Lights G5	TRI 23W Compact Fluor.	28 EA	4,965	0	\$535	\$0	\$150	\$894	2.00	6.02
Lights H1	17W CF Table Lamps	249 EA	23,384	0	\$2,499	\$0	\$1,245	\$4,876	1.40	8.60
Lights J1	150W HPS & Ballast	33 EA	5,448	0	\$673	\$0	\$320	\$6,568	9.05	1.33
Lights J2	200W HPS & Ballast	54 EA	23,475	0	\$2,578	\$0	\$1,129	\$6,387	3.06	3.92
Lights K1	Ceiling PIR Controls	239 EA	162,912	0	\$7,877	\$0	\$1,784	\$79,611	8.33	1.44
Lights K3	Wall Switch PIR Controls	162 EA	35,138	0	\$1,699	\$0	\$768	\$17,829	8.43	1.42
<b>Subtotal, Lighting Fixture and Control Retrofits</b>		<b>123.6</b>	<b>562,417</b>	<b>0</b>	<b>\$42,996</b>	<b>\$0</b>	<b>\$36,359</b>	<b>\$251,336</b>	<b>5.34</b>	<b>2.25</b>
<b>Totals for Successful ECOs (SIR's &gt; 1.0)</b>		<b>203.8</b>	<b>1,588,955</b>	<b>30,117</b>	<b>\$80,003</b>	<b>\$4,526</b>	<b>\$38,137</b>	<b>\$525,627</b>	<b>5.39</b>	<b>2.28</b>

5/4/06 - 5/27/06  
2003.500/yr  
APPROVAL: 0313ENGR/PREF/VALUARY.XLS Table 1-1

**EEAP Energy Savings Opportunity Survey  
Fort Huachuca, Arizona**

**Table 1-2. Summary of Life Cycle Cost Analyses for  
Central Heating / Cooling Plant Cogeneration Alternatives**

	Description of Cogeneration Alternative	Power kW	Investment	Annual Cost Savings		SIR	Payback Years
				Energy \$/Year	Non-Energy \$/Year		
Alternative 1A1 \$2,923 / Kw	Gas <u>Turbine-Generator</u> Cogeneration Facility serving Fort Huachuca's South Central Heating/Cooling Plant.	3,312	\$9,682,629	\$961,462	(\$29,459)	1.16	10.39
Alternative 1A2 \$2,873 / Kw	Gas <u>Turbine-Generator</u> Cogeneration Facility serving Fort Huachuca's North Central Heating/Cooling Plant.	3,312	\$9,517,018	\$935,657	(\$29,059)	1.13	10.50
Alternative 1B \$2,924 / kW	Gas <u>Turbine-Generator</u> Cogeneration Facility serving both South & North Central Heating/Cooling Plants.	4,727	\$13,821,209	\$1,610,329	\$1,396	1.51	8.58
Alternative 1C1 \$1,568 / kW	Gas <u>Engine-Generator</u> Cogeneration Facility serving both Central Heating/Cooling Plants: Ebullient Cooled, Single-Stage Absorption Chilling.	6,600	\$10,346,129	\$1,384,319	(\$29,531)	1.74	7.64
Alternative 1C2 \$1,654 / kW	Gas <u>Engine-Generator</u> Cogeneration Facility serving both Central Heating/Cooling Plants: Two-Stage Absorption Chilling.	8,800	\$14,559,263	\$1,915,853	(\$141,775)	1.55	8.21
Alternative 1C3 \$1,829 / kW	Gas <u>Engine-Generator</u> Cogeneration Facility serving both Central Heating/Cooling Plants: Ebullient Cooled, Single & Two-Stage Absorption Chilling.	5,500	\$10,059,783	\$1,186,046	\$4,348	1.60	8.45

**EEAP Energy Savings Opportunity Survey  
Fort Huachuca, Arizona**

**Table 1-3. Summary of Life Cycle Cost Analyses for  
Power Generation Alternatives Serving Fort Huachuca and Sierra Vista**

	Description of Cogeneration Alternative	Power kW	Investment	Annual Cost Savings		SIR	Payback Years
				Energy \$/Year	Non-Energy \$/Year		
Alternative 2 \$1,084 / kW	Gas Turbine Combined Cycle Cogeneration Facility serving Fort Huachuca and Sierra Vista. Power generated to match electric demand.	52,248	\$56,615,344	\$17,407,722	(\$1,237,129)	1.98	6.24
Alternative 3 \$1,718 / kW	Gas Turbine Combined Cycle Cogeneration Facility serving Fort Huachuca <u>only</u> . Power generation to match electric demand.	22,248	\$38,215,478	\$7,349,328	(\$481,712)	1.39	9.19
Alternative 2 Max \$1,084 / kW	Gas Turbine Combined Cycle Cogeneration Facility serving Fort Huachuca and Sierra Vista. Power generated at plant capacity with excess power sales through the grid.	52,248	\$56,615,344	\$22,514,378	(\$1,799,860)	1.89	5.88
Alternative 3 Max \$1,718 / kW	Gas Turbine Combined Cycle Cogeneration Facility serving Fort Huachuca <u>only</u> . Power generated at plant capacity with excess power sales through the grid.	22,248	\$38,215,478	\$9,911,580	(\$766,408)	1.54	7.83



## 2.0 Introduction

This report contains the results of all work for the Energy Engineering Analysis Program (EEAP), Energy Savings Opportunity Survey (ESOS) at Fort Huachuca, Arizona. The work was authorized under Contract Number DACA05-92-C-0155 with the U.S. Army Corps of Engineers, Sacramento District, Sacramento, California.

### 2.1 Purpose

The purpose of this energy survey is to develop a set of projects and actions that will reduce energy consumption and operating costs of selected facilities at Fort Huachuca, Arizona.

### 2.2 Scope

The scope of work as established by the U.S. Army Corps of Engineers, Sacramento District, consists of the following tasks:

- Limited site investigation of specific buildings and systems.
- Evaluation of specific energy conservation opportunities (ECOs) to determine economic feasibility.
- Monitoring of harmonic distortion, both voltage and current, at the main distribution panels in a group of buildings having large percentages of nonlinear loads.
- Feasibility evaluations of several cogeneration options, including: (a) Public Utilities Regulatory Policies Act (PURPA) Qualified Facilities to serve central boiler/chiller plants, (b) a facility to serve the total electric power requirements of both Fort Huachuca and the city of Sierra Vista, and (c) a facility to serve the total electric power requirements of Fort Huachuca.
- Preparation of funding documentation for recommended ECOs.
- Preparation of a comprehensive report documenting the data collected, analyses performed, and projects recommended.

The complete scope of work, together with minutes of the prenegotiation conference, appears in Appendix A. The final matrix of facilities to be surveyed and energy conservation measures to be evaluated that resulted from revisions to the scope of work appears in Table 2-1.

### 2.3 Methodology

The sequence of the study, in chronological order, progressed from the site investigation to the interim report preparation to the pre-final and final report preparation. Methodologies used during each phase of the study are addressed as follows:



**EEAP Energy Savings Opportunity Survey  
Fort Huachuca, Arizona**

**2.3.1 Site Investigation**

An entry briefing attended by the architect/engineer (A/E) and representatives of Fort Huachuca Directorate of Engineering and Housing (DEH) was held prior to beginning the facility inspections. Survey schedules and support requirements from Fort Huachuca DEH were discussed during this briefing.

Field team members then inspected buildings, lighting systems and HVAC systems and recorded findings on the standard forms developed by the A/E for this purpose. Harmonic distortion data were monitored and recorded using a Basic Measurement Instruments (BMI) Model 3030A harmonic analyzer. Approximately four hours of data were recorded at the main service panel of four facilities. In addition, "snapshots" of harmonic spectrums were taken on various distribution panels to aid in assessing harmonic current sources.

Copies of available architectural, mechanical and electrical as-built drawings were obtained for the buildings included in the survey as well as appropriate utility distribution plans and site maps.

An exit briefing was held at the completion of the facility investigations. The purpose of the briefing was to report progress and to report any maintenance needs or "quick fix" measures that could be readily implemented by DEH.

**2.3.2 Interim Report**

The first step in preparation of the Interim Report was the compilation of building databases for the survey population covering HVAC systems, lighting and building envelope data. Those buildings designated for evaluation of HVAC and insulation retrofits were modeled with the Carrier Hourly Analysis Program (HAP) to develop baseline energy usage and demand load estimates.

Following completion of the building databases and energy modeling, potential ECOs were evaluated for each study building according to the scope of work. Computer modeling, as described above, spreadsheet software and, where necessary, manual calculations were employed to determine the relative benefits of each ECO. Life cycle cost analyses were performed for all ECOs in accordance with the latest "Energy Conservation Investment Program (ECIP) Guidance."

The results of the ECO analyses were summarized into two listings as follows:

- (1) All ECOs that were analyzed and recommended, arranged in order of descending savings-to-investment ratio (SIR).
- (2) All ECOs that were analyzed and not recommended, arranged in order of descending SIRs.

**2.3.3 Prefinal and Final Reports**

Following the Interim Report presentation and review conference, funding documents will be prepared for combinations of viable ECOs as directed by the Government review. In addition,



**EEAP Energy Savings Opportunity Survey  
Fort Huachuca, Arizona**

revisions resulting from the review conference will be incorporated into these documents. For all projects with savings-to-investment ratios (SIRs) greater than 1.0, the following funding categories will apply:

- ECIP Project: Construction cost greater than \$300,000, simple payback period less than 10 years and SIR equal to or greater than 1.25.
- Regular Military Construction, Army (MCA) Program: Construction cost greater than \$300,000 and simple payback period of 4 to 25 years.
- Low Cost/No Cost projects: Projects that Fort Huachuca DEH can perform with in-house resources or by contract.



**EEAP Energy Savings Opportunity Survey  
Fort Huachuca, Arizona**

**Table 2-1**

POTENTIAL ECO EVALUATION LIST <sup>1</sup>								
Bldg.	Description	SF	Lighting	Motors	HVAC controls	Natural gas cooling	Low E roof	Insulation
15544	Instruction Building	12,990	X	X				X
20200	Residential Duplex	3,808	X	X				X
22422	Facilities Engineering Building	12,474	X	X				X
30118	Cold Storage Warehouse	17,577		X				
43002	Officers Club	31,430	X	X				
43083	Visitors Quarters	83,230		X				X
51005	Riley Barracks	250,000					X	
52054	Guest House	13,064		X				
53301	Communications Equipment	40,000	X	X				
56301	Communications Equipment	30,000	X	X	X	X	X	
57428	Communications Equipment	18,998	X	X				
61701	Gym and Indoor Pool	52,158	X	X				X
62704	Instruction Building	18,733	X	X				
67601	Middle School	50,000		X				
70525	NCO Club	22,464	X	X				X
80305	Barracks	50,680	X	X				
80505	TTA Instruction Building	72,000	X	X				
90312	Warehouse	36,920	X	X				X
90507	Salvage Storage	4,800	X	X				
90508	Storage Warehouse	8,640	X	X				
91114	Airfield Maintenance Hangar	35,973	X	X				X

<sup>1</sup>Based on Annex E and Enclosure 1 to the Scope of Work dated 25 January 1994 as revised by Supplemental Scope of Work dated 8 April 1994.



### 3.0 Description of Installation

#### 3.1 Location, Size and Climate

Fort Huachuca is located in Southern Arizona, approximately 70 miles southeast of Tucson, adjacent to the city of Sierra Vista, as shown in Figure 3-1. The installation covers 73,000 acres at an average elevation of 4,700 feet.

The summer design dry and wet bulb temperatures are 92° and 68°, respectively. These are the temperatures equalled or exceeded 2 1/2 percent of the time, on the average, during the warmest four consecutive months (June through September). The dry bulb temperature exceeds 80° an average of 1,154 hours per year and the wet bulb temperature exceeds 67° an average of 209 hours per year during the six warmest months of the year. The Fort Huachuca Meteorological Team reports the 30-year mean cooling degree days (the difference between mean daily temperature and a base temperature of 65°F) as 1,595 per year.

The winter design dry bulb temperature is 28°. This temperature is equalled or exceeded 2 1/2 percent of the time, on the average, during the coldest consecutive three months (December through February). Heating degree days (the difference between the mean daily temperature and a base temperature of 65°F), as listed in TM 5-785, total 2,551 annually. The Fort Huachuca Meteorological Team reports this value as the 30-year mean and averages of 2,500 and 2,510 heating degree days, respectively.

#### 3.2 Electrical Power and Natural Gas Utilities

Electrical power is provided to Fort Huachuca by Tucson Electric Power (TEP) Company via 138kV primary and 46kV alternate aerial subtransmission lines. The primary transformer is rated 25/33/42 MVA and the alternate transformer is rated 15/20/25 MVA. Capacitor banks for power factor correction at the 13.8kV substation busses have increased the average power factor as measured by TEP to approximately 0.95. Power distribution to facilities throughout the Fort is via both aerial 13.8kV lines and underground 13.8kV cable.

Daily electricity consumption for the period from 1 March 1993 through 31 March 1994 is shown in Figure 3-2. Historical maximum electrical demands by month for the period October 1984 to March 1994 is shown in Figure 3-3, indicating a consistent pattern of growth.

Power factors for the period of October 1984 through March 1994 are plotted on Figure 3-4. Recent improvements in the power factor are fairly dramatic.

Natural gas is delivered to Fort Huachuca by Southwest Gas Company via two 4-inch, 400 psi lines, one paralleling Arizona State Highway 90 and the other entering the Fort west of the built-up area. Pressure reducing stations as well as gas company metering mark the transition to the Government-owned distribution system. Historical natural gas consumption by month is shown in Figure 3-5.



### 3.3 Central Heating/Cooling Plants

There are two central heating/cooling plants at Fort Huachuca: the North Plant (Building 81504) which is currently in operation, and the South Plant (Building 62701), which is currently undergoing a major expansion that essentially duplicates the North Plant installation.

#### 3.3.1 North Central Heating/Cooling Plant

Cooling is provided by three Trane 400-ton water-cooled centrifugal chillers sized to serve the following buildings: seven barracks, two dining halls, a battalion headquarters, TTA/TTD facility, MCD/EMCS facility, and the NCO Academy. Heating is provided by two 8400 MBH, gas-fired hot water boilers, manufactured by ABCO, each sized for 88 percent of the total load of the above listed buildings.

A chilled water thermal storage system consisting of tankage with a capacity of 480,000 gallons is provided with a total system capacity of 3,500 Ton-hours and a demand capability of 400 Tons. Two injection pumps, each rated for 750 gpm at 152 feet of head, move chilled water from the tanks into the distribution system during charging or discharging.

The central plant is physically arranged with the chillers and boilers installed at grade level, three induced draft Baltimore Air Coil cooling towers installed on grade and the chilled water, condenser water and thermal storage injection pumps located in the basement below the chillers.

Control of the plant is via a Johnson Controls Metasys system interfaced to direct digital controls. Software includes demand-limiting algorithms to sequence operation of the chillers and thermal storage system. In December of 1994, a construction contract was awarded to simplify the controls in the central plant.

Energy-saving features incorporated into the central plant design include a plate-and-frame heat exchanger rated at 3,600 MBH to provide free cooling during low-load conditions and variable frequency drives for three 25 HP cooling tower fan motors and two 50 HP thermal storage injection pumps. An isolation transformer is installed on the line side of each variable frequency drive to block injection of current harmonics into the plant's electrical distribution system.

#### 3.3.2 South Central Heating/Cooling Plant

Heating and cooling loads of the following buildings are planned to be served by the South Plant when the expansion project is completed: MTD facility, OPS facility, BMD facility, NCO Academy, NCO Barracks, plus 240,000 square feet of future construction. Estimated diversified cooling load is 1,500 tons and total estimated heating load is 11,124 MBH. Similar to the North Plant, an estimated 400 tons of cooling will be provided by a chilled water thermal storage system.



Figure 3-1

Fort Huachuca Location Map

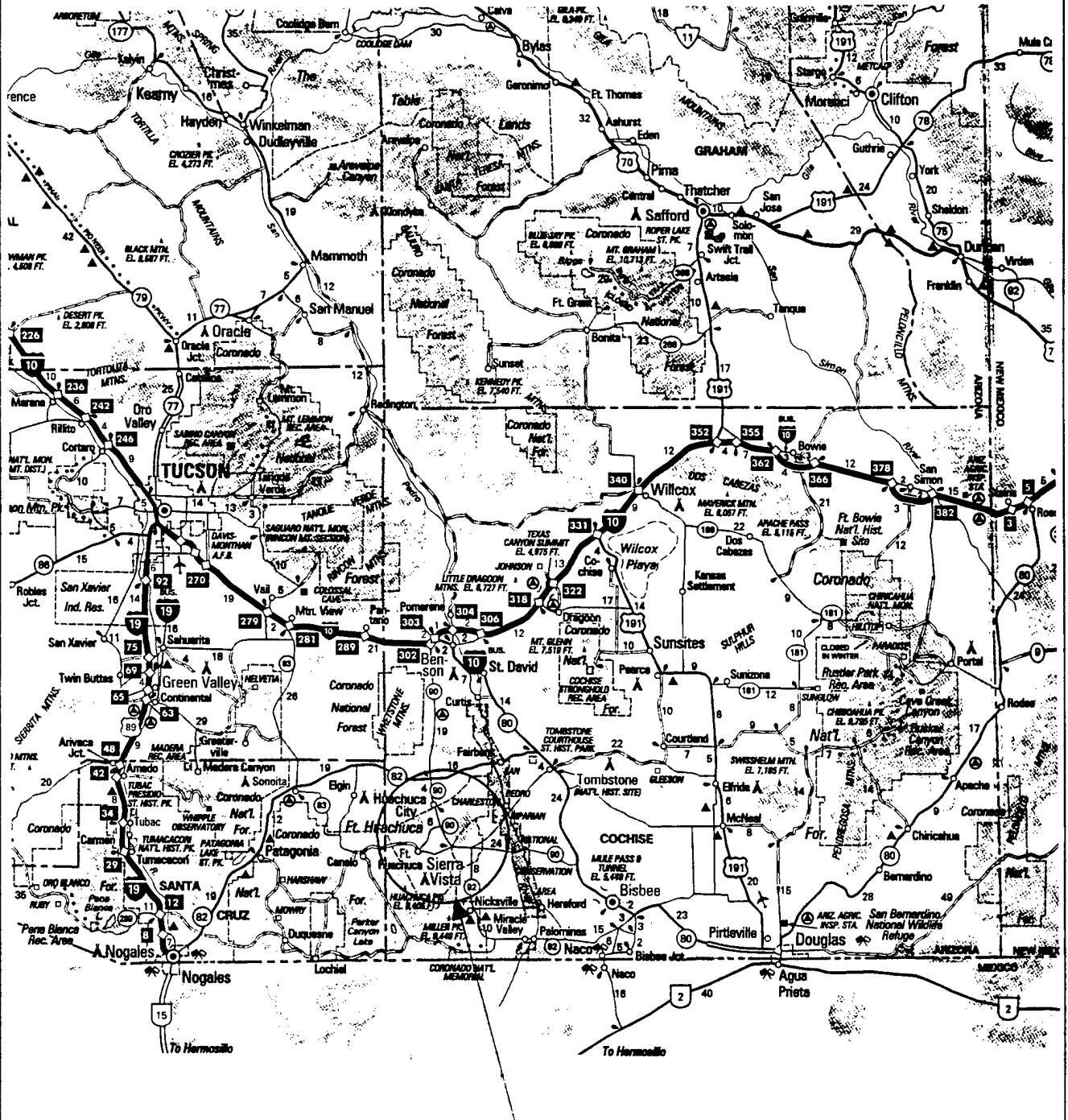

FORT  
HUACHUCA

Figure 3-2. Fort Huachuca Historical Electric Demand March '93 to '94  
Maximum kW Demands per Day  
Note reductions each weekend

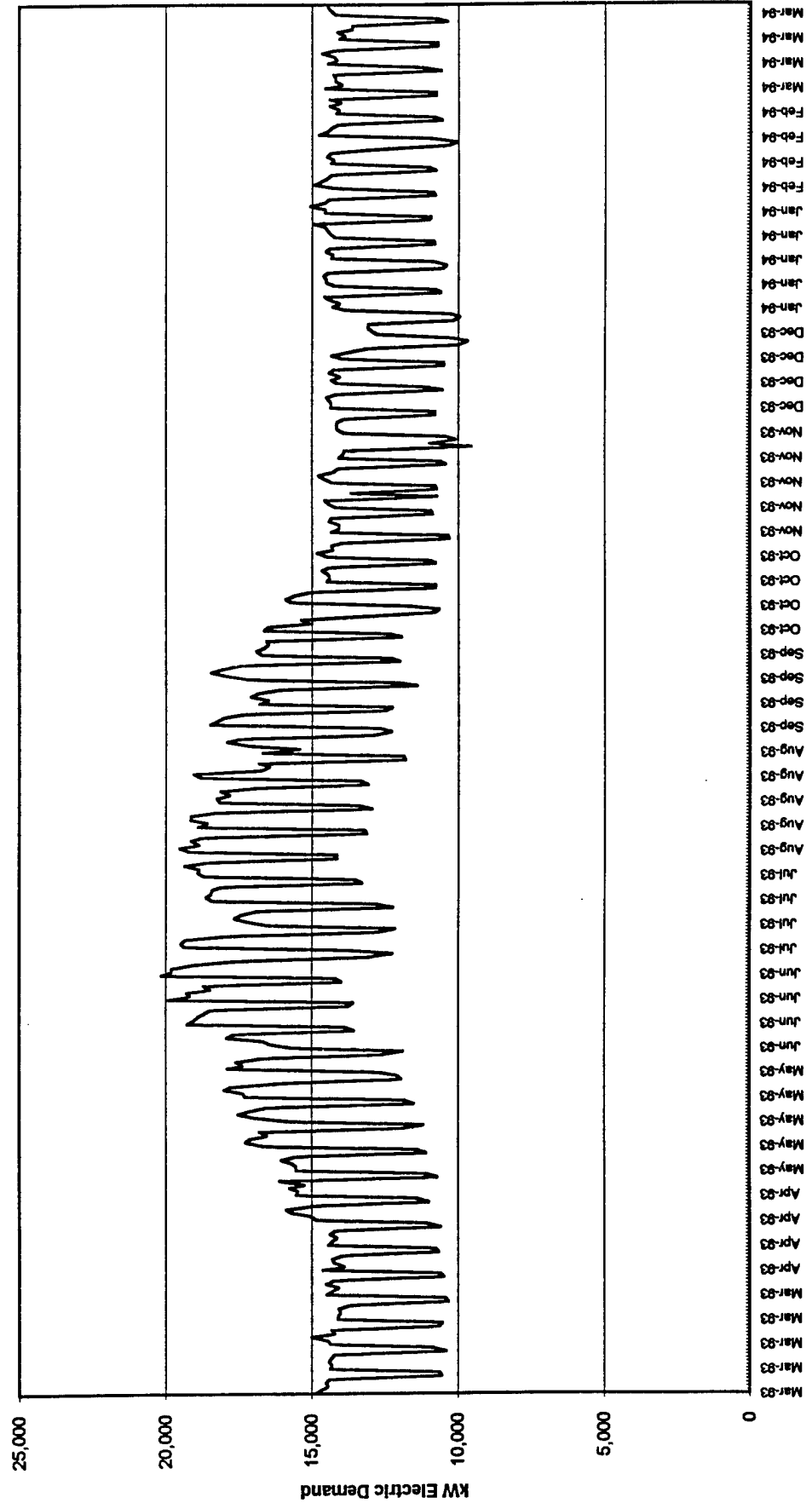

EEAP Energy Savings Opportunity Survey  
Fort Huachuca, Arizona

Figure 3-3. Fort Huachuca Historical Electrical Demand for 1984 to 1994  
Maximum Monthly kW Demands

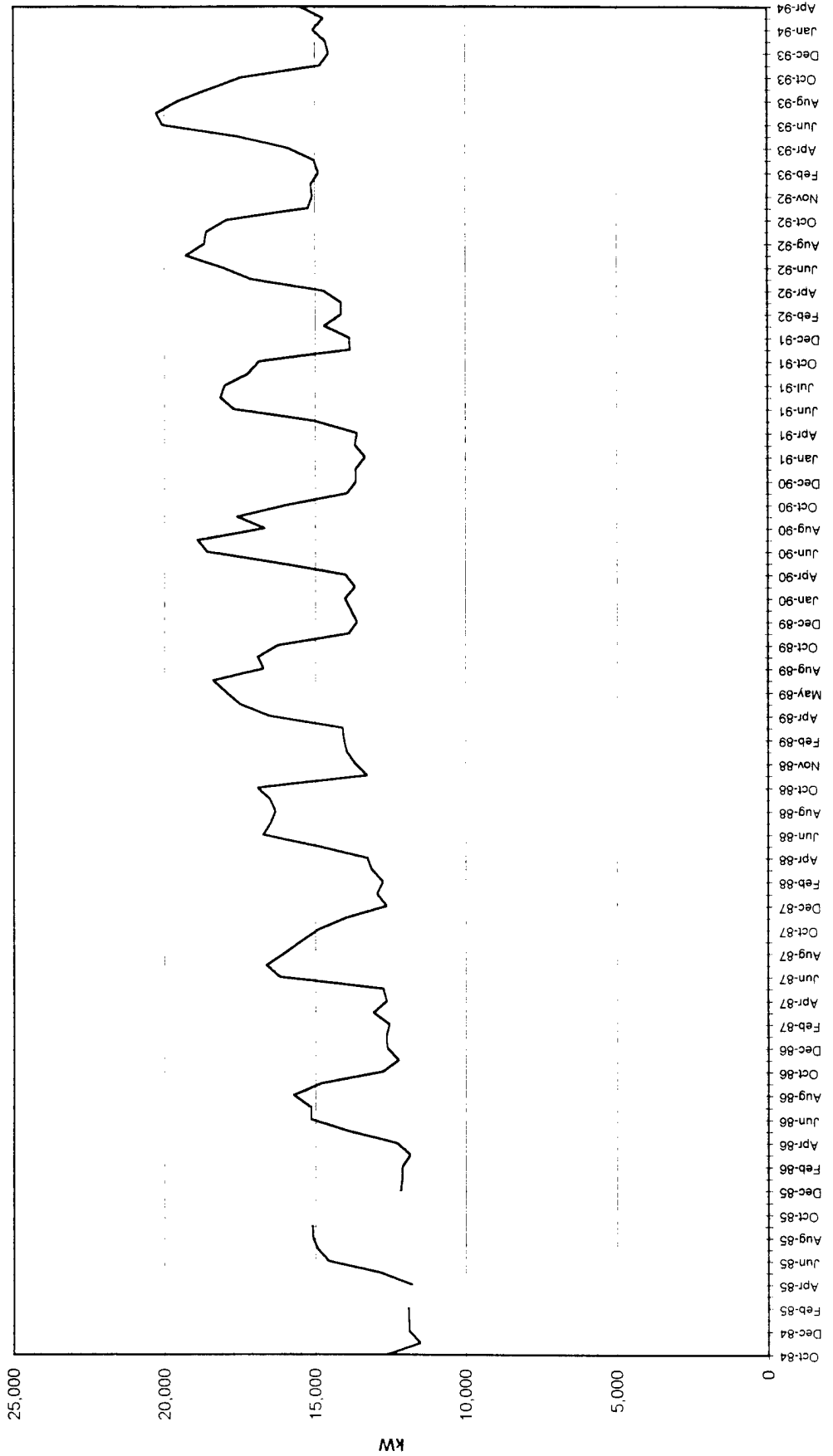

EEAP Energy Savings Opportunity Survey  
Fort Huachuca, Arizona

Figure 3-4. Fort Huachuca Historical Power Factor for 1984 to 1994  
Monthly Average Power Factor in Percent

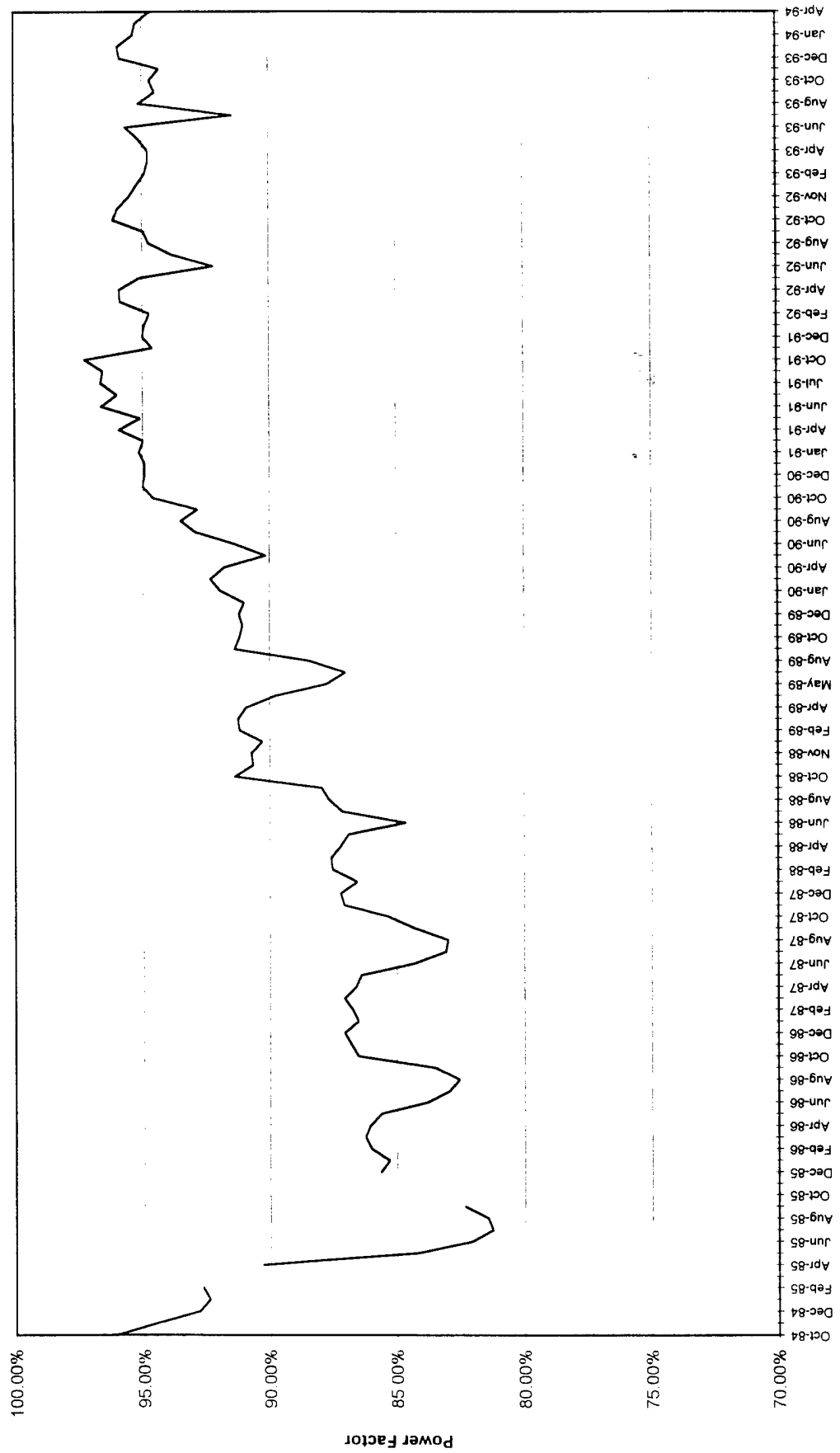

## 4.0 Energy Conservation Evaluations

### 4.1 Life Cycle Cost Analysis Assumptions

#### 4.1.1 Economic Assumptions

Economic analyses based on present value techniques were performed for all potential energy conservation opportunities using the economic analysis form and procedures outlined in "Energy Conservation Investment Program (ECIP) Guidance" dated January 1994. The following assumptions and methods were used to develop standard input for economic analysis of all projects:

- a. Investment costs include the following: Construction costs; contingency estimated at 10% of construction costs; supervision, inspection and overhead (SIOH) at 6% of construction costs; and design at 6% of construction costs. To compute total investment, the sum of the above costs was reduced by the amount of the expected utility rebate, if applicable.
- b. The economic analysis was performed based on current (fourth quarter FY94) costs.
- c. Discount factors and uniform present value factors used in computing present values are obtained from the supplement to NIST Handbook 135, "Energy Prices and Discount Factors for Life-Cycle Cost Analysis 1995." The discount rate set for 1994 by the Dept. of Energy is equivalent to a market rate of 6.6%. Allowing for an assumed rate of general price inflation yields a "real" discount rate lower than the 3.0 percent floor prescribed in 10 CFR 436. Thus, the 3.0 percent floor is used as a real discount rate for FY1995 analyses. Uniform present value factors (designated UPV\*) using the 3.0% discount rate and adjusted for average fuel price escalation in the industrial sector for Census Region 4 are used in the analyses below.
- d. The present value of recurring non-energy benefits and costs was obtained using a 0% differential rate and a 3.0% discount rate.

#### 4.1.2 Energy Cost Assumptions

##### 4.1.2.1 Electricity

Electric power is provided to Fort Huachuca by Tucson Electric Power Company under "Large Light and Power Rate No. 14," which includes a demand charge with ratcheting provision, an energy charge and an adjustment for power factor. Current rates—including the effect of Arizona sales tax, Arizona Corporation Commission assessment and power factor discount used in the analyses—are as follows:



Electrical Demand Charge

Demand Charge	\$10.17	per kW per Month
Power Factor Correction:	(\$0.065)	per kW per Month (see below)
Adjusted Demand Charge:	\$10.105	per kW per Month
Arizona Sales Tax and Arizona Corporation Commission Assessment Charges:	5.43%	
Total Electric Demand Charge:	\$10.653	per kW per Month, or
	\$127.84	per kW per Year.

Electrical Usage Charges

Electrical usage charges depend on the time of year. They are:

May through October:	\$0.04694	per kWh
November through April:	\$0.04459	per kWh

Usage charges are also subject to the 5.43% Arizona Sales Tax and Corporation Commission Assessment Charges. The seasonal rates, considering the latest complete year of electrical consumption records results in a weighted-average Total Electric Usage Charge of:

	\$0.04835	per kWh
(\$4.17 per Million BTU's, or	\$0.01343	per Million Joules)

Power Factor Correction

The power factor correction is \$0.013 per kW per Month per percent power factor above (+) or below (-) 90 percent. The maximum discount allowed is \$0.13 per kW per Month.

**4.1.2.2 Natural Gas**

Natural gas is provided to Fort Huachuca by the Central Arizona Division of Southwest Gas Corporation. Under rate schedule "CG-35 Gas Service to Armed Forces." The commodity charge for natural gas is \$0.42758 per therm. Including Arizona sales tax and Arizona Corporation Commission assessment yields a billing rate of \$0.4508 per therm (\$4.508 per million BTUs or \$0.0041 per million Joules).

Copies of current (third quarter 1994) utility rate schedules appear in Appendix B.

**4.2 Construction Cost Estimate Methodology**

Construction costs are estimated for each energy conservation opportunity evaluated. Cost estimates may be considered as a budgeting level of accuracy. Labor and material costs are based predominantly on the 1994 Means Cost Estimating Guides with adjustments for geographic location and difficulty of retrofit work, as appropriate. Whenever feasible, budget quotes from equipment manufacturers have been used to improve accuracy.



Factors added to the subtotal of labor and materials costs include:

- Arizona Transaction Privilege Tax at 3.75% (added to materials cost only)
- Contractor Overhead and Profit at 25%
- Bond at 1.5%
- Estimating Contingency at 10%

The resulting total probable construction costs are subsequently used in life cycle cost analyses.

Energy conservation opportunities are estimated assuming that construction contracts are let to contractors who specialize in each project type. Costs are reduced in this way, by eliminating the extra charges for subcontractor services.

Cogeneration and power generation alternatives are evaluated using cost estimates which assume the use of a general contractor and subcontractors.

#### **4.3 Utility Rebate Programs**

Tucson Electric Power Company (TEP), the electric utility serving Fort Huachuca, currently offers the following energy conservation retrofit rebate programs applicable to Fort Huachuca facilities:

- Commercial and Industrial Lighting Efficiency Program
- Commercial and Industrial Motor Efficiency Program
- Commercial and Industrial High Efficiency Air Conditioning Program (Proposed for 1994)

The lighting program provides per unit rebates for specific lighting equipment retrofits including compact and T-8 fluorescent lamps, electronic ballasts, reflectors, occupancy sensors, LED and fluorescent retrofitted exit signs, and indoor high-pressure sodium or metal halide fixture conversions. TEP will dispose of the old ballasts at no cost to the customer. Rebates for this program are limited to \$40,000 annually per customer.

The motor efficiency program provides rebates for replacement motors that meet a specified minimum qualifying efficiency which equals or exceeds the standard definition for energy-efficient motors provided in National Electrical Manufacturers Association (NEMA) Publication MG 1, News Release dated March 1989. In addition to the "base" rebate for meeting the minimum qualifying efficiency, an additional "bonus factor" is multiplied times the NEMA nominal percent efficiency that the new motor exhibits in excess of the qualifying level.



The high efficiency air conditioning prescriptive program provides rebates for air conditioning equipment that meets minimum qualifying efficiencies, expressed as EER (Energy Efficiency Ratio) for unitary air conditioners and heat pumps or kW/Ton for water chillers. If the new cooling unit efficiency exceeds the minimum qualifying efficiency, an additional rebate per 0.1 EER or 0.01kW/Ton is added to the base rebate.

Copies of TEP rebate schedules appear in Appendix B.

#### **4.4 Energy Conservation Opportunities Studies**

ECOs evaluated in this study are briefly described in the following paragraphs:

##### **4.4.1 Energy-Efficient Motor Retrofits**

The survey was limited to motors with rated horsepower of 5 HP or more, since units below this size do not qualify for TEP rebates and have little likelihood of cost-effective retrofits. Generally, economic replacement of operational standard-efficiency motors with energy-efficient units requires a high level of annual operating hours. Refer to Appendix C for a summary of motor test data and retrofit evaluations.

##### **4.4.2 Building Envelope Retrofits**

Baseline energy consumption and energy savings resulting from envelope retrofits were calculated using the Carrier HAP simulation program. Wall insulation retrofits considered included installation of blown-in, batt or rigid fiberglass board insulation, depending on wall construction, to achieve as high an insulating value as possible within the constraints of the existing construction. Roof insulation retrofits considered included fiberglass batt or rigid fiberglass board insulation to achieve an insulating value of R-30. Application of a low-emissivity coating, such as LO/MIT-1, to roof exterior surfaces was also considered for each of the buildings evaluated for insulation retrofits. Refer to Appendix D for Carrier HAP simulation results and Appendix E for building envelope retrofit analyses.

##### **4.4.3 HVAC Controls Retrofits**

The HVAC system at the Communications Equipment Building 56301 was evaluated for the following three controls modifications:

- Integrated dry bulb temperature control that positions the economizer damper based on a comparison of return and outside air temperatures,
- Supply air temperature reset control based on outside air temperature, and
- Supply air temperature reset control based on the zone with the greatest demand.

Refer to Appendix F for calculations.



#### 4.4.4 Lighting and Controls Retrofits

Specific lighting and lighting controls retrofits for the study buildings are listed as follows:

ECO I.D.	DESCRIPTION OF RETROFIT	TYPE
A	Exit Fixture LED Retrofit	Fixture
B1	Install Electronic Ballasts - 2 Lamp F30T12 Fixtures, or	Fixture
B2	Install Electronic Ballasts and T8 Lamps - 2 Lamp F30T12 Fixtures	Fixture
C1	Install Electronic Ballasts - 1 Lamp F32T8 Fixtures	Fixture
C2	Install Electronic Ballasts - 2 Lamp F32T8 Fixtures	Fixture
D1	Install Electronic Ballasts and T8 Lamps - 1 Lamp F34T12 and F40T12 Fixtures	Fixture
D2	Install Electronic Ballasts and T8 Lamps - 2 Lamp F34T12 and F40T12 Fixtures	Fixture
D3	Install Electronic Ballasts and T8 Lamps - 3 Lamp F34T12 and F40T12 Fixtures	Fixture
D4	Install Electronic Ballasts and T8 Lamps - 4 Lamp F34T12 and F40T12 Fixtures	Fixture
D5	Install Reflector and Delamp 4 Lamp Fixtures to 3 Lamps with Electronic Ballasts and T8 Lamps	Fixture
E1	Install Electronic Ballasts - 2 Lamp F48T12HO Fixtures	Fixture
E2	Install Electronic Ballasts and T8 Lamps - 2 Lamp F40T12U Fixtures	Fixture
E3	Install Electronic Ballasts and T8 Lamps - 3 Lamp F40T12U Fixtures	Fixture
F1	Install Electronic Ballasts and T8 Lamps - 2 Lamp F96T12 Fixtures	Fixture
F2	Install Electronic Ballasts and T8 Lamps - 4 Lamp F96T12 Fixtures	Fixture
G1	Install DTT 13W Compact Fluorescent Lamps for Downlight Incandescents	Fixture
G2	Install TRI 20W Compact Fluorescent Lamps to Replace Incandescents	Fixture
G3	Install TT 7W Compact Fluorescent Lamps to Replace Incandescents	Fixture
G4	Install DTT 13W Compact Fluorescent Lamps for Ceiling Incandescents	Fixture
G5	Install TRI 23W Compact Fluorescent Lamps to Replace Incandescents	Fixture
H1	Install 17W Compact Fluorescent Lamps for Incandescent Table Lamps	Fixture
J1	Install 150W HPS Lamps and Ballasts to Replace 250W MV Lamps	Fixture
J2	Install 200W HPS Lamps and Ballasts to Replace 400W MV Lamps	Fixture
K1	Install Ceiling Mounted PIR Occupancy Sensors to Control Lights	Control
K2	Install Ceiling Mounted Ultrasonic Occupancy Sensors to Control Lights	Control
K3	Install Wall Switch Type PIR Occupancy Sensors to Control Lights	Control



Refer to Appendix G for lighting survey data and baseline energy demand/consumption calculations and Appendix H for retrofit calculations and life-cycle cost analyses.

#### 4.4.5 Natural Gas Cooling Retrofits

For the CETEC Communications Equipment Building 56301, the feasibility of replacing the existing electric-powered chiller with a natural gas engine-driven unit was evaluated. Refer to Appendix K for calculations and life-cycle cost analysis of this marginally-attractive project.

#### 4.5 Recommended Energy Conservation Projects

A summary of overall analysis results for recommended ECOs, with projects arranged in order of descending SIR, appears in Table 4-1; and a summary of analysis results for ECOs not recommended appears in Table 4-2. Individual summaries of analysis results for each ECO category appear in the following tables:

Table 4-3: Energy-efficient motor retrofits

Table 4-4: Building envelope retrofits

Table 4-5: HVAC controls retrofits

Table 4-6: Lighting and controls retrofits



Table 4-1. Summary of Analysis Results for Recommended ECOs

Building or ECO Number	Retrofit Description	Electric (kW)	Energy Savings		Energy Cost Savings		O&M Savings (\$/Year)	Utility Rebate (\$)	Investment Payback (\$)	Economic Measures	
			Electric (kWH/Year)	Gas (Million BTU/yr)	Electric (\$/Year)	Gas (\$/Year)				(\$/Year)	(Years)
Lights G2	TRI 20W Compact Fluor.	2.4	4,547	0	\$523	\$0	\$6,284	\$35	\$62	0.08	153.60
56301	Apply Low E Roof Coating	0.0	149,852	567	\$9,426	\$1,994	\$141,556	\$0	\$6,437	0.56	21.99
Lights H1	17W CF Table Lamps	10.7	23,384	0	\$2,499	\$0	\$30,043	\$1,245	\$4,876	1.40	8.60
Lights G1	DTT 13W CF-Downlights	2 EA	139	0	\$18	\$0	\$218	\$10	\$37	1.44	8.36
Lights G4	DTT 13W CF-Ceiling	2.1	3,786	0	\$446	\$0	\$5,360	\$230	\$876	1.48	8.12
Lights G3	TT 7W Compact Fluor.	2.4	4,488	0	\$519	\$0	\$6,239	\$225	\$1,166	1.52	7.87
15544	SA Fan HVAC Unit	1.2	10,783	0	\$679	\$0	\$10,235	\$80	\$1,356	2.00	7.55
Lights G5	TRI 23W Compact Fluor.	2.3	4,965	0	\$535	\$0	\$6,435	\$150	\$894	2.00	6.02
80505	SA Fan East	0.9	7,536	0	\$474	\$0	\$7,154	\$85	\$1,266	2.67	5.65
80505	SA Fan West	0.9	7,536	0	\$474	\$0	\$7,154	\$85	\$1,266	2.67	5.65
80505	RA Fan East	0.4	3,226	0	\$203	\$0	\$3,062	\$56	\$578	2.85	5.30
80505	RA Fan West	0.4	3,226	0	\$203	\$0	\$3,062	\$56	\$578	2.85	5.30
62704	SA Fan	0.6	4,974	0	\$313	\$0	\$4,721	\$87	\$1,091	3.48	4.33
43083	SA Fan AHU No. 1	0.2	2,068	0	\$130	\$0	\$1,963	\$46	\$476	3.66	4.12
43083	SA Fan AHU No. 2	0.2	2,068	0	\$130	\$0	\$1,963	\$46	\$476	3.66	4.12
Lights J2	200W HPS & Ballast	11.3	23,475	0	\$2,578	\$0	\$30,985	\$159	\$8,387	3.06	3.81
Lights D5	Delamp 4 to 3 T8s, Ballasts	49.3	144,543	0	\$13,296	\$0	\$159,823	\$12,749	\$43,531	3.16	3.92
56301	SA Fan, North HVAC Unit	0.3	2,246	0	\$141	\$0	\$2,132	\$56	\$578	4.09	3.69
56301	SA Fan, Central HVAC Unit	0.3	2,246	0	\$141	\$0	\$2,132	\$56	\$578	4.09	3.69
56301	SA Fan, South HVAC Unit	0.3	2,246	0	\$141	\$0	\$2,132	\$56	\$578	4.09	3.69
62704	RA Fan	0.3	2,246	0	\$141	\$0	\$2,132	\$56	\$578	4.09	3.69
61701	Pool Circ. Pump	0.4	3,472	0	\$219	\$0	\$3,296	\$75	\$947	4.33	3.48
80505	Fan Coil Unit, Rm 213	5	1,789	0	\$113	\$0	\$1,698	\$35	\$520	4.62	3.26
91114	HW Circ. Pump	0.3	1,439	0	\$91	\$0	\$1,366	\$17	\$421	4.65	3.24
80505	HWP-1	0.3	1,459	0	\$92	\$0	\$1,385	\$46	\$476	5.19	2.91
Lights E1	Ballasts 2 xF48T12HO	1.6	5,491	0	\$468	\$0	\$5,625	\$192	\$2,107	4.50	2.67
43083	Roof. Insulation & Low E	0.0	124,909	1,228	\$7,857	\$4,318	\$155,623	\$0	\$58,567	4.81	2.66
56301	CHW Circ. Pump 1	0.3	1,168	0	\$73	\$0	\$1,108	\$17	\$421	5.73	2.63
80505	Fan Coil Unit, Rm 249	0.2	1,935	0	\$122	\$0	\$1,836	\$48	\$708	5.82	2.59
80505	CHWP-1	0.4	1,959	0	\$123	\$0	\$1,859	\$56	\$766	6.21	2.43
80505	CHWP-2	0.4	1,959	0	\$123	\$0	\$1,859	\$58	\$766	6.21	2.43
56301	Economizer Control & SA Reset @ OA Temp	0.0	382,501	28,726	\$1,577	\$1,443	\$39,403	\$0	\$16,548	5.48	2.38
91114	Apply Low E Roof Coating	6,979 SF	5,460	(16)	\$343	(\$57)	\$3,321	\$0	\$1,498	5.23	2.22
Lights B2	Ballasts/T8s 2xF30T12	3.7	8,124	0	\$868	\$0	\$10,438	\$1,240	\$5,502	5.66	2.12
51005	Apply Low E Roof Coating	78,400 SF	12,401	928	(\$906)	\$3,264	\$35,364	\$0	\$16,822	7.13	2.10
80505	VAVH2 West, Roof FCU	0.2	1,676	0	\$105	\$0	\$1,591	\$58	\$766	7.26	2.08

Table 4-1. Summary of Analysis Results for Recommended ECOs

Building or ECO Number	Retrofit Description	Electric		Energy Savings		Energy Cost Savings		O&M Savings (\$/Year)	Utility Rebate (\$)	Investment (\$)	Economic Measures	
		(KW)	(KWH/Year)	Gas (Million BTU/yr)	Electric (\$/Year)	Gas (\$/Year)	LCC Savings (\$)				Payback (Years)	SIR
80505	VAVH2, Roof FCU	0.2	1,676	0	\$105	\$0	\$1,591	\$0	\$58	\$766	7.26	2.08
Lights A	LED Exit Fixtures	2.0	17,171	0	\$1,082	\$0	\$13,000	(\$165)	\$972	\$5,438	5.94	2.03
67601	AHU 1 SA Fan	0.5	887	0	\$95	\$0	\$1,438	\$0	\$58	\$766	8.03	1.88
67601	AHU 2 SA Fan	0.5	887	0	\$95	\$0	\$1,438	\$0	\$58	\$766	8.03	1.88
67601	AHU 3 SA Fan	0.5	887	0	\$95	\$0	\$1,438	\$0	\$58	\$766	8.03	1.88
67601	AHU 4 SA Fan	0.5	887	0	\$95	\$0	\$1,438	\$0	\$58	\$766	8.03	1.88
67601	AHU 5 SA Fan	0.5	887	0	\$95	\$0	\$1,438	\$0	\$58	\$766	8.03	1.88
67601	AHU 7 SA Fan	0.5	887	0	\$95	\$0	\$1,438	\$0	\$58	\$766	8.03	1.88
15544	Wall & Roof Insul + Low E Roof Coat	0.0	27,927	442	\$1,750	\$1,556	\$43,080	\$0	\$0	\$24,210	7.32	1.78
56301	CHW Circ. Pump 2	0.2	727	0	\$46	\$0	\$691	\$0	\$17	\$421	9.20	1.64
Lights D2	Ballasts/T8, 2x40T12	30.0	107,700	0	\$9,046	\$0	\$108,733	(\$48)	\$14,010	\$67,229	7.47	1.61
20200	Retrofit Roof Insulation	0.0	4,029	64	\$253	\$226	\$6,245	\$0	\$0	\$4,147	8.65	1.51
56301	Condenser Fan 1	0.2	661	0	\$46	\$0	\$694	\$0	\$46	\$476	10.35	1.46
56301	Condenser Fan 2	0.2	661	0	\$46	\$0	\$694	\$0	\$46	\$476	10.35	1.46
Lights K1	Ceiling PIR Controls	0.0	162,912	0	\$7,877	\$0	\$94,679	\$1,676	\$1,784	\$79,611	8.33	1.44
Lights K3	Wall Switch PIR Controls	0.0	35,138	0	\$1,699	\$0	\$20,421	\$416	\$768	\$17,829	8.43	1.42
57305	CHW Circ. Pump 2	0.5	2,368	0	\$149	\$0	\$2,248	\$0	\$88	\$1,623	10.89	1.38
Lights J1	150W HPS & Ballast	3.2	5,448	0	\$673	\$0	\$8,085	\$54	\$320	\$6,568	9.05	1.33
Lights D1	Ballasts/T8, 1x40T12	1.7	9,066	0	\$658	\$0	\$7,912	(\$136)	\$1,080	\$5,217	9.99	1.20
56301	Gas Engine-Driven Chiller - 72 Tons	67.0	267,690	(1,823)	\$21,508	(\$8,218)	\$142,078	(\$1,032)	\$0	\$122,512	9.99	1.06
Lights F1	Ballasts/T8, 2x40T12	0.8	1,872	0	\$193	\$0	\$2,317	(\$32)	\$200	\$1,822	11.35	1.06
Lights F2	Ballasts/T8, 4x40T12	0.1	166	0	\$18	\$0	\$220	(\$3)	\$20	\$182	11.73	1.03
<b>Totals for Successful ECOs (SIR's &gt; 1.0)</b>		<b>203.8</b>	<b>1,588,955</b>	<b>30,117</b>	<b>\$90,003</b>	<b>\$4,526</b>	<b>\$1,161,876</b>	<b>\$3,073</b>	<b>\$38,137</b>	<b>\$525,627</b>	<b>5.39</b>	<b>2.28</b>

Table 4-2. Summary of Analysis Results for ECOs Not Recommended

Building or ECO Number	Energy Saving Retrofit	Energy Savings		Gas (Million BTU/yr)		Electric (\$/Year)		Energy Cost Savings		O&M Savings (\$/Year)	Utility Rebate (\$)	Investment Payback (\$)	SIR (Years)
		(kW)	(kWh/Year)	Gas	Electric	Gas	Electric	LCC Savings (\$)					
Lights D4	Ballasts/T8, 4XF40T12, or D5	29.9	85,882	0	\$7,972	\$0	\$95,829	\$68,095	8.58	1.40			
56301	DB Control & SA Rest @ Zone or OA Air	0.0	385,988	30,504	\$1,410	\$680	\$26,580	\$23,939	11.46	1.11			
Lights B1	Ballasts, 2 x F30T12, or B2	1.6	3,521	0	\$9	\$0	\$4,523	\$4,437	11.79	1.02			
43083	Wall Insulation	89,946 SF	86,981	9,813	5,471	3,451	\$114,659	\$142,055	15.92	0.81			
53301	SA Fan	50 HP ODP	1,577	0	\$99	\$0	\$1,496	\$1,855	18.70	0.81			
Lights C2	Ballasts, 2 x F32T8	553 EA	13,718	0	\$1,441	\$0	\$17,320	\$4,424	15.31	0.79			
67601	HVAC Sys. Circ. Pump	15 HP ODP	354	0	\$38	\$0	\$574	\$766	20.11	0.75			
70525	Furnace SA Fan	10 HP ODP	520	0	\$40	\$0	\$608	\$852	21.13	0.71			
Lights E2	Ballasts/T8, 2XF40T12U	1 EA	41	0	\$3	\$0	\$41	\$70	17.06	0.70			
61701	Low-E Roof Coating	49,288 SF	11,772	(450)	\$740	(\$158)	\$6,660	\$9,674	16.61	0.69			
20200	Wall & Roof Insulation	1,565 SF	2,282	345	144	121	\$3,446	\$5,327	20.10	0.65			
Lights E3	Ballasts/T8, 3XF40T12U	1 EA	45	0	\$4	\$0	\$45	\$105	22.30	0.54			
53301	SA Fan HVAC Unit	30 HP ODP	640	0	\$40	\$0	\$608	\$1,264	31.36	0.48			
91114	Wall Insulation	21,758 SF	11,224	947	706	333	\$13,204	\$28,223	27.16	0.47			
91114	Roof Insulation	21,758 SF	3,567	265	224	93	\$4,016	\$8,638	27.21	0.46			
Lights C1	Ballasts, 1 x F32T8	111 EA	1,674	0	\$166	\$0	\$1,996	\$4,346	26.17	0.46			
Lights D3	Ballasts/T8, 3XF40T12	575 EA	14,974	0	\$1,239	\$0	\$14,887	\$40,998	33.83	0.36			
61701	Roof Insulation	49,288 SF	14,694	1,012	924	356	\$16,150	\$50,850	39.73	0.32			
70525	Wall Insulation	36,478 SF	5	409	0	144	\$2,040	\$6,965	48.36	0.29			
Lights K2	Ceiling Ultrasonic Control	124 EA	15,450	0	\$747	\$0	\$8,979	\$41,682	44.68	0.27			
61701	Wall Insulation	49,288 SF	38,325	2,323	2,411	817	\$40,552	\$245,756	76.14	0.17			
90312B	Roof Insulation	240 SF	32	0	2	0	\$24	\$224	111.63	0.11			
90312A	Roof Insulation	350 SF	40	0	2	0	\$30	\$327	131.48	0.09			
90312A	Wall Insulation	350 SF	49	0	3	0	\$37	\$772	248.49	0.05			
70525	Low-E Roof Coating	36,478 SF	(2)	(178)	(\$0)	(\$63)	(\$889)	\$6,523	(103.98)	(0.14)			
20200	Low-E Roof Coating	1,565 SF	0	(109)	\$0	(\$38)	Not Evaluated because no energy is saved						

Note: The two lighting projects shown above (with descriptions ending "or B2", "or OA Air" and "or D5" are the less successful evaluations of two alternative projects evaluated for the same energy saving purpose. The alternative with the higher SIR is recommended; the less successful alternative is listed above.

Table 4-3. Summary of Energy Efficient Motor Retrofit Evaluations

Building No.	Equipment	Motor Enclosure HP	Oper. Hours/ Month	Oper. Months/ Year	Existing Efficiency	New Efficiency [4]	Est. Avg. Load Factor	Savings kW	Savings \$/Year [5]	Savings LCC \$ [6]	Construction Cost \$ [6]	SIOH & Design \$	TEP Rebate \$	Total Investment \$	SIR		
15544	SA Fan HVAC Unit	20	730	12	0.830	0.920	0.70	1.231	\$678	\$10,235	\$1,282	\$154	\$80	\$1,356	7.55		
43083	SA Fan AHU No. 1	7.5	730	12	0.853 (2)	0.896	0.75	0.236	\$130	\$1,963	\$466	\$56	\$46	\$476	4.12		
43083	SA Fan AHU No. 2	7.5	730	12	0.853 (2)	0.896	0.75	0.236	\$130	\$1,963	\$466	\$56	\$46	\$476	4.12		
53301	SA Fan HVAC Unit	30	730	12	0.924	0.928	0.70	0.073	\$40	\$608	\$1,206	\$145	\$87	\$1,264	0.48		
53301	SA Fan	50	730	12	0.930	0.936	0.70	0.190	\$577	\$99	\$1,763	\$212	\$119	\$1,855	0.81		
56301	CHW Circ. Pump 1	6	730	6	0.815	0.879	0.80	0.267	\$168	\$73	\$391	\$47	\$17	\$421	2.63		
56301	CHW Circ. Pump 2	6	730	6	0.838 (2)	0.879	0.80	0.166	\$72	\$46	\$91	\$47	\$17	\$421	1.64		
56301	SA Fan, North HVAC Unit	10	730	12	0.872 (2)	0.911	0.70	0.256	\$246	\$141	\$2,132	\$68	\$56	\$578	3.69		
56301	SA Fan, Central HVAC Unit	10	730	12	0.872 (2)	0.911	0.70	0.256	\$246	\$141	\$2,132	\$68	\$56	\$578	3.69		
56301	SA Fan, South HVAC Unit	10	730	12	0.872 (2)	0.911	0.70	0.256	\$246	\$141	\$2,132	\$68	\$56	\$578	3.69		
56301	Condenser Fan 1	7.5	500	6	0.853 (2)	0.896	0.70	0.220	\$61	\$46	\$466	\$56	\$46	\$476	1.46		
56301	Condenser Fan 2	7.5	500	6	0.853 (2)	0.896	0.70	0.220	\$61	\$46	\$466	\$56	\$46	\$476	1.46		
57305	CHW Circ. Pump 2	25	730	6	0.895	0.925	0.80	0.541	\$236	\$149	\$2,248	\$183	\$88	\$1,023	1.38		
61701	Pool Circ. Pump	20	730	12	0.895	0.920	0.88	0.396	\$472	\$219	\$3,296	\$110	\$75	\$947	3.48		
62704	RA Fan	10	730	12	0.872 (2)	0.911	0.70	0.256	\$246	\$141	\$2,132	\$68	\$56	\$578	3.69		
62704	SA Fan	25	730	12	0.892 (2)	0.928	0.70	0.568	\$474	\$313	\$4,721	\$126	\$87	\$1,091	4.33		
67601	AHU 1 SA Fan	15	180	9	0.860	0.915	0.70	0.547	\$87	\$95	\$1,438	\$88	\$58	\$766	1.88		
67601	AHU 2 SA Fan	15	180	9	0.860	0.915	0.70	0.547	\$87	\$95	\$1,438	\$88	\$58	\$766	1.88		
67601	AHU 3 SA Fan	15	180	9	0.860	0.915	0.70	0.547	\$87	\$95	\$1,438	\$88	\$58	\$766	1.88		
67601	AHU 4 SA Fan	15	180	9	0.860	0.915	0.70	0.547	\$87	\$95	\$1,438	\$88	\$58	\$766	1.88		
67601	AHU 5 SA Fan	15	180	9	0.860	0.915	0.70	0.547	\$87	\$95	\$1,438	\$88	\$58	\$766	1.88		
67601	AHU 7 SA Fan	15	180	9	0.860	0.915	0.70	0.547	\$87	\$95	\$1,438	\$88	\$58	\$766	1.88		
67601	HVAC Sys. Circ. Pump	15	180	9	0.895	0.915	0.80	0.218	\$54	\$38	\$736	\$88	\$58	\$766	1.88		
70525	Furnace SA Fan	10	365	6	0.860 (2)	0.895 (3)	0.70	0.237	\$20	\$40	\$786	\$96	\$40	\$852	0.75		
80505	CHWP-1	15	730	6	0.875	0.915	0.80	0.447	\$159	\$123	\$1,859	\$88	\$58	\$766	2.43		
80505	CHWP-2	15	730	6	0.875	0.915	0.80	0.447	\$159	\$123	\$1,859	\$88	\$58	\$766	2.43		
80505	HWP-1	7.5	730	6	0.840	0.896	0.80	0.333	\$159	\$92	\$1,395	\$56	\$46	\$476	2.91		
80505	Fan Coil Unit, Rm 249	5	730	12	0.852 (2)	0.895 (3)	0.70	0.221	\$935	\$122	\$1,836	\$81	\$46	\$708	2.59		
80505	Fan Coil Unit, Rm 213	5	730	12	0.833 (2)	0.875 (3)	0.95	0.204	\$178	\$113	\$496	\$59	\$35	\$520	3.28		
80505	VAVH2 West, Roof FCU	15	730	12	0.895	0.915	0.70	0.191	\$176	\$105	\$1,591	\$88	\$58	\$766	2.08		
80505	VAVH2, Roof FCU	15	730	12	0.895	0.915	0.70	0.191	\$176	\$105	\$1,591	\$88	\$58	\$766	2.08		
80505	SA Fan East	30	730	12	0.883	0.928	0.70	0.860	\$756	\$474	\$7,154	\$145	\$85	\$1,266	5.65		
80505	SA Fan West	30	730	12	0.883	0.928	0.70	0.860	\$756	\$474	\$7,154	\$145	\$85	\$1,266	5.65		
80505	RA Fan West	10	730	12	0.858	0.911	0.70	0.368	\$226	\$203	\$3,062	\$68	\$56	\$578	5.30		
80505	RA Fan East	10	730	12	0.858	0.911	0.70	0.368	\$226	\$203	\$3,062	\$68	\$56	\$578	5.30		
91114	HV Circ. Pump	5	730	6	0.815	0.879	0.99	0.328	\$439	\$91	\$1,369	\$47	\$17	\$421	3.24		
Totals for Motor Retrofits with BIR > 1.0																	
									13,213	78,671	\$6,198	\$78,386	\$22,615	\$2,714	\$1,778	\$23,661	3.33

(1) ODP = Open Drip Proof  
 (2) TEFC = Totally Enclosed Fan-Cooled  
 (3) Assumed Value, Based on Average Standard Motor Efficiencies  
 (4) Minimum Qualifying Efficiency for TEP Rebate  
 (5) Average Efficiency for Energy Efficient Motor from DOE Energy Efficient Electric Motor Selection Handbook, Rev. 3, January 1993  
 (6) Energy Cost Saved is based on \$0.04835 per kWh and \$127.84 per kW-Year, usage and demand costs, respectively.  
 (7) See Table C-3

Table 4-4. Summary of Building Envelope Retrofit Evaluations

Building Number	Insulation Retrofit		Energy Savings		Energy Cost Savings		Investment (\$)	Payback (Years)	SIR
	Roof	Wall	Electric (kWH/Year)	Gas (Million BTU/Yr)	Electric (\$/Year)	Gas (\$/Year)			
15544	•	•	27,827	442	\$1,750	\$1,556	\$43,080	7.32	1.78
20200	-	-	4,029	64	\$253	\$226	\$6,245	8.65	1.51
43083	•	-	124,909	1,228	\$7,857	\$4,318	\$155,623	4.81	2.66
51005	•	-	(14,401)	928	(\$906)	\$3,264	\$35,364	7.13	2.10
56301	•	-	149,852	567	\$9,426	\$1,994	\$141,556	0.56	21.99
61701	-	-							
70525	-	-							
90312A	-	-							
90312B	-	-							
91114	•	-	5,460	(16)	\$343	(\$57)	\$3,321	5.23	2.22
<b>Totals</b>	•	•	<b>297,676</b>	<b>3,214</b>	<b>\$18,724</b>	<b>\$11,301</b>	<b>\$385,191</b>	<b>3.72</b>	<b>3.45</b>

Note that only those insulation projects are listed above for which Life Cycle Cost Analyses resulted in an SIR above 1.0. Insulation retrofits recommended for each building are indicated by "•" symbols, above.

**Table 4-5. Summary of HVAC Control Retrofit Evaluations**

**Energy Costs and Adjustment Factors**  
 Electric Usage Cost & Taxes, including demand charges:  
 \$0.0629 per KWH 12.02 Uniform Present Worth, N=15  
 Natural Gas Cost, including Taxes:  
 \$4.5080 per Mil BTU 14.17 Uniform Present Worth, N=15

**Adjustment for El Paso, Texas vs. Fort Huachuca Energy Use:**  
 Location Heating DD/Year Cooling DD/Year  
 Simulations @ El Paso, Texas 2,678 2,098  
 Actual Site Fort Huachuca 2,551 1,595  
 Adjustment Factors: 0.953 0.760

Economizer Control Description	Electric kWH/Year	Gas Therms/Yr	Savings kWH/Year	Savings Therms/Yr	Elec Saved (\$/Year)	Gas Saved (\$/Year)	Constr. Cost (\$)	Invest- ment (\$)	LCCA Saved (\$)	SIR
Note: Both Supply Air Reset Options include										
Baseline	415,473	32,087	-	-	-	-	-	-	-	-
Supply Reset - Outside Air Temperature	382,501	28,726	25,067	3,202	\$1,577	\$1,443	\$14,775	\$16,548	\$39,403	2.38
Supply Reset - Greatest Zone Demand	385,988	30,504	22,416	1,508	\$1,410	\$680	\$21,374	\$23,939	\$26,580	1.11

**Recommended Control Retrofit: Integrated Dry-Bulb Temperature Control with Supply Air Temperature Reset (Economizer Control)**  
 Based on Outside Air Temperature

Table 4 - 6. Summary of Lighting and Controls Retrofit Evaluations

Lighting ECO Number	Description	Number Retrofit Units	Demand Saved (kW)	Energy Saved (kWH/Year)	Total LCC Cost Saved (\$)	ECO Investment (\$)	SIR	Payback (Years)
A	Exit Fixture LED Retrofit	108	1.97	17,171	\$11,025	\$5,438	2.03	5.94
B1	Install Electronic Ballasts - 2 Lamp F30T12 Fixtures, or	124	1.61	3,521	\$4,523	\$4,437	1.02	11.79
B2	Install Electronic Ballasts and T8 Lamps - 2 Lamp F30T12 Fixtures	124	3.72	8,124	\$11,682	\$5,502	2.12	5.66
C1	Install Electronic Ballasts - 1 Lamp F32T8 Fixtures	111	0.67	1,674	\$1,996	\$4,346	0.46	26.17
C2	Install Electronic Ballasts - 2 Lamp F32T8 Fixtures	553	6.08	13,718	\$17,320	\$22,059	0.79	15.31
D1	Install Electronic Ballasts and T8 Lamps - 1 Lamp F34T12 & F40T12 Fixtures	120	1.72	9,066	\$6,286	\$5,217	1.20	9.99
D2	Install Electronic Ballasts and T8 Lamps - 2 Lamp F34T12 & F40T12 Fixtures	1,401	30.03	107,700	\$108,164	\$67,229	1.61	7.47
D3	Install Electronic Ballasts and T8 Lamps - 3 Lamp F34T12 & F40T12 Fixtures	575	4.03	14,974	\$14,570	\$40,998	0.36	33.83
D4	Install Electronic Ballasts and T8 Lamps - 4 Lamp F34T12 & F40T12 Fixtures, or	671	29.88	85,882	\$95,385	\$68,095	1.40	8.58
D5	Install Reflector and Delamp 4 Lamp Fixtures to 3 Lamps with Electronic Ballasts and T8	671	49.34	144,543	\$165,753	\$43,531	3.81	3.16
E1	Install Electronic Ballasts - 2 Lamp F48T12HO Fixtures	48	1.58	5,491	\$5,625	\$2,107	2.67	4.50
E2	Install Electronic Ballasts and T8 Lamps - 2 Lamp F40T12U Fixtures	1	0.01	41	\$49	\$70	0.70	17.06
E3	Install Electronic Ballasts and T8 Lamps - 3 Lamp F40T12U Fixtures	1	0.01	45	\$56	\$105	0.54	22.30
F1	Install Electronic Ballasts and T8 Lamps - 2 Lamp F96T12 Fixtures	20	0.80	1,872	\$1,932	\$1,822	1.06	11.35

Table 4 - 6. Summary of Lighting and Controls Retrofit Evaluations

Lighting ECO Number	Description	Number Retrofit Units	Demand Saved (kW)	Energy Saved (kWH/Year)	Total LCC Cost Saved (\$)	ECO Investment (\$)	SIR	Payback (Years)
F2	Install Electronic Ballasts and T8 Lamps - 4 Lamp F96T12 Fixtures	1	0.08	166	\$187	\$182	1.03	11.73
G1	Install DTT 13W Compact Fluorescent Lamps for Downlight Incandescents	2	0.09	139	\$306	\$37	8.36	1.44
G2	Install TRI 20W Compact Fluorescent Lamps to Replace Incandescents	24	2.37	4,547	\$9,598	\$62	153.60	0.08
G3	Install TT 7W Compact Fluorescent Lamps to Replace Incandescents	71	2.36	4,488	\$9,175	\$1,166	7.87	1.52
G4	Install DTT 13W Compact Fluorescent Lamps for Ceiling Incandescents	45	2.06	3,786	\$7,117	\$876	8.12	1.48
G5	Install TRI 23W Compact Fluorescent Lamps to Replace Incandescents	28	2.31	4,965	\$5,386	\$894	6.02	2.00
H1	Install 17W Compact Fluorescent Lamps for Incandescent Table Lamps	249	10.71	23,384	\$41,911	\$4,876	8.60	1.40
J1	Install 150W HPS Lamps and Ballasts to Replace 250W MV Lamps	33	3.20	5,448	\$8,724	\$6,568	1.33	9.05
J2	Install 200W HPS Lamps and Ballasts to Replace 400W MV Lamps	54	11.29	23,475	\$32,880	\$8,387	3.92	3.06
K1	Install Ceiling Mounted PIR Occupancy Sensors to Control Lights	239	0.00	162,912	\$114,686	\$79,611	1.44	8.33
K2	Install Ceiling Mounted Ultrasonic Occupancy Sensors to Control Lights	124	0.00	15,450	\$11,200	\$41,682	0.27	44.68
K3	Install Wall Switch Type PIR Occupancy Sensors to Control Lights	162	0.00	35,138	\$25,393	\$17,829	1.42	8.43
<b>Total Successful Lighting Fixture and Controls Retrofits</b>		<b>3,400</b>	<b>123.62</b>	<b>562,417</b>	<b>\$565,829</b>	<b>\$251,336</b>	<b>2.25</b>	<b>5.34</b>

## 5.0 Harmonic Distortion Survey

### 5.1 Description of the Problem

Increased office efficiency and the penetration of energy savings devices have resulted in the proliferation of non-linear loads, i.e., loads that draw a non-sinusoidal current waveform when energized by a sinusoidal waveform. A non-sinusoidal current waveform is comprised of the fundamental 60 Hz wave plus current waveforms at multiples of the 60 Hz wave shape.

The most common sources of harmonic current distortion (and, consequently voltage distortion) are personal computers and other electronic equipment containing switch mode power supplies and several widely-implemented energy conservation retrofits, namely, variable speed motor drives and electronic fluorescent lamp ballasts.

Potential problems caused by harmonic currents and voltage distortion include:

- Overloading neutral conductors of four-wire systems with harmonic currents that result from unbalanced single-phase harmonic-laden loads plus the additive effect of triplen (3rd, 9th, 12th, etc.) harmonic currents.
- Increased heating of motor windings leading to failure or reduced life expectancy.
- Increased losses in transformers leading to potential overheating.
- Disruption of sensitive electronic equipment operation.

### 5.2 Methodology and Data Summary

Four facilities at Fort Huachuca containing significant computer loads or electronic fluorescent ballasts were selected to be monitored at the main service distribution panel for a minimum duration of four hours each. One facility - Rodney Hall, Building 41402 - was submonitored at several distribution panelboards and with electronic-ballasted lighting both energized and deenergized in an attempt to characterize the relative magnitudes of the harmonic sources in the distribution system. A BMI 3030A power analyzer was used to monitor the various power service points and to record the data on floppy disks for subsequent evaluation.

A summary of harmonic distortion monitoring data collected during the site investigation appears in Table 5-1.

Data summarized include minimums and maximums during the monitoring periods for demand kW, average power factor, average voltage, total harmonic distortion (THD), and average current THD. Total harmonic distortion is defined as follows:



$$\text{Voltage THD} = \left( \frac{\text{Sum of all squares of amplitudes of all harmonic voltages}}{\text{Square of the amplitude of the fundamental voltage}} \right)^{1/2} \times 100\%$$

$$\text{Voltage THD} = \left( \frac{\sum^{50} V_h^2}{V_1^2} \right)^{1/2} \times 100\%$$

where h is the order of the harmonic voltage.

$$\text{Current THD} = \left( \frac{\text{Sum of all squares of amplitudes of all harmonic currents}}{\text{Square of the amplitude of the fundamental current}} \right)^{1/2} \times 100\%$$

$$\text{Current THD} = \left( \frac{\sum^{50} I_h^2}{I_1^2} \right)^{1/2} \times 100\%$$

where h is the order of the harmonic current.

### 5.3 Evaluation and Recommendations

ANSI/IEEE Standard 519-1992 "IEEE Recommended Practices and Requirement for Harmonic Control in Electrical Power Systems" provides recommended voltage and current distortion limits. These limits are applicable to the "point of common coupling" with the utility system, or that point at which a customer's service tees off from the general utility system serving other customers. The recommended voltage distortion limits are 5 percent total voltage distortion THD with any individual harmonic limited to 3 percent. The recommended current distortion limits depend on the size of the load in comparison to the size of the power system at the point of connection, defined as  $I_{SC}/I_L$ , the ratio of available short circuit current to maximum fundamental load current.

A review of the voltage distortion data collected indicates that, in all cases, the average voltage THDs meet the 5 percent limitation.

The monitored current distortion data is expressed as a percentage of the measured fundamental load current rather than as a percentage of maximum demand load current as used in ANSI/IEEE Standard 519. Therefore, the measured distortion values must be adjusted to approximate values of total current demand distortion (TDD) prior to comparisons with the guidelines.

Table 5-2 was prepared to compare harmonic levels in the monitored buildings with the IEEE guidelines. As shown, TDDs estimated from the metered data were generally higher than those recommended in ANSI/IEEE Standard 519. It should be noted, however, that the harmonics data was collected during early May, not during the peak air conditioning season when motor loads increase significantly. Since motor loads are linear, TDDs are expected to decrease from those shown in Table 5-2 during the peak cooling months. The overnight recording of the main service



**EEAP Energy Savings Opportunity Survey  
Fort Huachuca, Arizona**

to Building 57305 clearly illustrates the effect of linear air conditioning loads with the current THD increasing from a daytime peak-load minimum of 6.2 percent to a nighttime maximum of 28.5 percent.

A review of the metering data indicates that both transformer capacities and neutral conductor sizes are adequate for the existing conditions. Snapshot data of neutral currents are summarized as follows:

Building Number	Phase Current			Neutral Current			Neutral to Phase Percentage
	Average of Fundamental Currents	Average Current THD	Total RMS Current	Fundamental Current	Current THD	Total RMS Current	
22320	75 Amps	18%	89 Amps	9 Amps	208%	28 Amps	31%
41402	52 Amps	15%	60 Amps	26 Amps	76%	46 Amps	77%
57305	604 Amps	11%	670 Amps	113 Amps	31%	148 Amps	22%
80505	180 Amps	10%	198 Amps	18 Amps	56%	28 Amps	14%

Since existing magnetic ballasts probably have current distortion levels exceeding 20 percent THD, retrofits with T8-lamp electronic ballasts specified with current THDs limited to 10 percent should reduce the harmonic distortion levels at both distribution panelboards and the building's service entrance.

If equipment operating problems are experienced that can be attributed to harmonic distortion, then some or all of the following actions may be taken to reduce harmonics to tolerable levels:

- In distribution panelboards with single-phase loads, rearrange circuits among phases to balance currents, thus reducing the neutral current.
- In branch circuits with significant harmonic distortion levels – probably those heavily loaded with personal computers or other electronic devices, provide isolation transformers.
- For large individual or groupings of small sensitive electronic equipment, provide active power line conditioners that combine adaptive and active harmonics filtering, transient voltage surge suppression and line voltage regulation.
- Provide harmonic filters for variable frequency drives (if not already installed internally) or separate isolation transformers.



**EEAP Energy Savings Opportunity Survey  
Fort Huachuca, Arizona**

**Table 5-1  
Summary of Harmonic Distortion Monitoring Data**

Building No.	Load Description	Date(s)	Time		Demand kW			Average Power Factor <sup>1</sup>			Average Voltage Percent THD <sup>2</sup>			Average Current Percent THD <sup>2</sup>		
			From	To	Min	Max	Min	Avg	Max	Min	Avg	Max	Min	Avg	Max	
22320	Main Service	5/9/94	0814	1300	22.1	210.4	.89	.92	.95	3.4	5.0	5.3	12.1	17.6	28.3	
41402	Main Service	5/9/94	1455	(snap-shot)	17.6	—	—	.95	—	—	4.4	—	—	14.5	—	
	Main Service with All Lighting Off	5/9/94	1552	(snap-shot)	5.6	—	—	.87	—	—	4.5	—	—	48.8	—	
57305	Basement Lighting Panel, 1 Ø	5/9/94	1400	1500	4.0	9.0	.88	.91	.97	4.3	4.5	4.6	16.7	32.0	40.2	
	Main Service	5/6-7/94	0900	0500	195.9	679.4	.72	.97	.98	3.7	4.3	4.9	6.2	15.5	28.5	
	Main Service 1	5/5-6/94	1200	0700	63.0	138.8	.64	.69	.76	3.0	3.6	4.0	7.0	8.8	11.5	
80505	Main Service 2	5/3/94	1815	2200	62.0	78.8	.64	.66	.68	3.0	3.4	3.7	7.3	8.5	10.4	

<sup>1</sup>Averages of three phases

<sup>2</sup>Averages of three phase THDs as a percentage of the fundamental magnitude

**EEAP Energy Savings Opportunity Survey  
Fort Huachuca, Arizona**

**Table 5-2  
Comparison of Monitored Harmonics Levels with IEEE Guidelines**

Building No.	Load Description	Transformer		Estimated Fault Duty, I <sub>sc</sub> (Amperes)	Estimated Maximum Demand, I <sub>L</sub>	I <sub>sc</sub> /I <sub>L</sub>	Avg. Measured Current THD <sup>1</sup>	Estimated Current TDD <sup>2</sup>	IEEE TDD
		Voltage	kVA						
22320	Main Service	120Y/208	150	16,000	300	53	17.6	14.7	12.0
41402	Main Service	120Y/208	300	16,000	300	53	14.5	12.7	12.0
57305	Main Service	277Y/480	2,500	35,000	900	39	15.5	13.4	8.0
80505	Main Service 1	277Y/480	750	14,000	350	40	8.8	8.1	8.0
80505	Main Service 2	277Y/480	750	14,000	350	40	8.5	7.8	8.0

<sup>1</sup>Total root-mean-square harmonic distortion as a percent of the fundamental

<sup>2</sup>Estimated Total Demand Distortion (TDD) =  $\frac{\text{Avg. Measured Current THD}}{1 + \text{Avg. Measured Current THD}}$

## 6.0 Cogeneration Feasibility Evaluations

The following cogeneration alternatives were evaluated for feasibility of implementation at Fort Huachuca:

Alternative 1: Cogeneration facility to serve existing central heating/cooling plants in Buildings 81504 (North Plant) and 62701 (South Plant), including expansion of the South Plant currently under construction. The following alternatives were considered:

- A. Separate qualified facilities (QF) under PURPA regulations
- B. Combined QF under PURPA, tied together with interconnected hot water and chilled water piping.

Alternative 2: Cogeneration facility with capacity to supply the total electric power requirements of both Fort Huachuca and the City of Sierra Vista.

Alternative 3: Cogeneration facility to serve the total electric power requirements of Fort Huachuca.

### 6.1 Natural Gas Piping Capacity

Southwest Gas Corporation was contacted concerning the adequacy of existing high pressure piping to serve possible power generating facilities being investigated.

Alternative 1 cogeneration plant sizes should be able to be served with existing interstate capacity, however a 4-inch dedicated high pressure pipeline is required between the regulating station and the plant site. The probable site for the Alternative 1 plant is about 3,000 feet away from the regulating station.

Alternative 2 and 3 sized cogeneration facilities cannot be served from the existing gas distribution system on post or upstream from Southwest's regulating station. In-depth engineering analysis will be required to determine the additional facilities and associated costs.

A request for determining the extent of the required upgrades has been forwarded to Southwest Gas Corporation. Budget costs to install gas piping from a point 4.5 miles from possible Alternative 2 and 3 sites are included in the construction cost estimates. These costs, based on Mean's construction cost estimating guides, are provided for evaluation purposes in this study.

The installation of these pipelines would be evaluated by the gas company to determine if the investment could be amortized within their tariff regulation.

An alternative is to install the pipeline at the project's expense. Possible rate adjustments might be negotiated with this approach.



## 6.2 Turbine-Generator Facilities to Serve Central Heating/Cooling Plants

For the purposes of evaluating feasibility, the conceptualized systems consist of natural gas turbine-generator sets, waste heat recovery steam boilers, two-stage steam absorption chillers for cooling and steam-to-hot water heat exchangers for heating. The absorption chiller and waste heat recovery boiler components are sized to match the cooling and heating loads, while the turbine-generator sets are sized as large as possible to fit within PURPA guidelines.

A typical system flow diagram for the individual plant or combined North and South Plant cogenerating facilities appears in Figure 6-1. Heating and cooling capacity calculations are summarized in the following paragraphs:

### South Central Plant Capacities (Building 62701):

Cooling: 1,500 Tons total design load, including future building expansions  
(400) Tons available from cold water storage system at peak conditions  
1,100 Tons required capacity to satisfy cooling load

Heating: 11,124 kBTUH total design load, including future building expansions

### North Central Plant Capacities (Building 81504):

Cooling: 1,370 Tons total design load; 3,500 Ton-Hours cold water storage available  
(400) Tons from cold water storage system at peak conditions (assume 8 hours use)  
970 Tons required capacity to satisfy cooling load

Heating: 9,545 kBTUH total design heating load (based on 2 hot water boilers of 8,400 kBTUH capacity sized for 88% of total load each)

Design basis performance is as follows, assuming no diversity of loads:

Alternative 1A1:	1,100 Tons Cooling	11,124 kBTUH Heating
Alternative 1A2:	970 Tons Cooling	9,545 kBTUH Heating
Alternative 1B:	2,070 Tons Cooling	20,669 kBTUH Heating

PURPA requires that useful thermal energy recovered from exhaust must be greater than five percent of the total energy input. Additionally, PURPA requires electricity generated plus 50 percent of the useful thermal energy recovered must be equal to or greater than 42.5 percent of the fuel energy input.

The conceptual feasibility analyses are based on performance data from Solar Turbines, Inc. for the gas turbine generating units and waste heat recovery steam boilers and from York for the



absorption chillers. Maximum output from the turbine generating set is 3,312 kW for both individual plant alternatives and 4,727 kW for the PURPA qualifying facility serving both central heating/cooling plants.

Results of the analyses are summarized in Table 6-1. As shown, the individual plant facilities, Alternatives 1A1 and 1A2, do not meet PURPA qualifying facility requirements with the turbine generating set operating at full rated capacity. The cogeneration facility serving both central plants, Alternative 1B, both meets PURPA QF requirements and achieves economic justification.

Refer to Appendix J for backup data to the cogeneration analyses.

### 6.3 Engine-Generator Facilities to Serve Central Heating/Cooling Plants

An Alternative 1B-sized cogenerating facility -- one that is sized to serve both North and South Central Plants -- is reevaluated for reciprocating engine-generators. Reciprocating engines offer heat recovery potential from both jacket cooling water and from the engine exhaust. Jacket water heat recovery is usually low temperature (below about 250°F) while exhaust heat recovery can be at higher temperatures.

Chilled water can be provided from single- and two-stage absorption chillers. Two-stage absorption chillers require high pressure steam, single-stage absorption chillers require only about 15 psig steam. Single stage absorption chillers require about twice the steam as two-stage absorption chillers.

York previously offered an YPC-HR series of heat recovery absorption chillers that provided both hot water and chilled water when coupled directly to an internal combustion engine's exhaust and jacket cooling water. Unfortunately, this line has been discontinued. A cogeneration system providing chilled and hot water from a gas engine-generator set now requires separate heat recovery boilers and absorption chillers.

Three configurations using engine-generator sets are evaluated. All three evaluations are based on operating and cost data for Waukesha Model VHP7100GSI gas-fired generating sets. The first (Alternative 1C1) employs low pressure steam production in ebullient cooled engines. Heat recovery boilers are installed to generate 15 psig steam for use in three-single stage absorption chillers. See Figure 6-3.

The second configuration (Alternative 1C2) uses the same engine-generator set with high pressure steam production to feed two two-stage steam absorption chillers. See Figure 6-4.

The third configuration (Alternative 1C3) is a combination of the first two. High pressure steam is generated from exhaust gasses and low pressure steam is generated from jacket cooling water. The high pressure steam is used in a two-stage absorption chiller while the lower pressure steam from jacket cooling water is used in two single-stage absorption chillers. See Figure 6-5.



Results of the analyses are summarized in Table 6-1; and backup data to the engine-generator cogeneration analyses appears in Appendix J.

#### **6.4 Turbine-Generator Facilities to Serve Fort Huachuca and the City of Sierra Vista**

These alternatives are evaluated assuming a combined-cycle gas turbine generating plants sized to serve the total projected electrical power requirements of both Fort Huachuca and the City of Sierra Vista (Alternative 2) and the total projected electrical power requirements of Fort Huachuca (Alternative 3). The facilities are conceived as Exempt Wholesale Generators (EWGs) under the Energy Policy Act of 1992, without cogeneration, since the only thermal loads practically available — the North and South Central Heating/Cooling Plant loads — represent but a fraction of the thermal output of a generating plant with the capacity to serve an installation the size of Fort Huachuca.

Siting of the generating plant under both alternatives is assumed to be west of the TEP Company Main Transformer Station. Another possible site for the Alternative 2 generating plant would be adjacent to the Arizona Electrical Power Cooperative Karchner Substation located on Kayetean Drive near Fort Huachuca's East Gate. This is one of two 69 kV service points to the Sulfur Springs Valley Electrical Cooperative system in the Sierra Vista area. The other Sierra Vista service point is the San Rafael Substation located two miles east of Highway 92 on Buffalo Soldier Trail, with a 69 kV tie line to the Karchner Substation.

##### **6.4.1 Electrical Demands for Fort Huachuca**

Based on records made available by Tucson Electric Power Company, the peak electric power demand for 1993 is listed at 20,148 kW; baseload demand exceeded 90 percent of the time is 8,745 kW based on recorded hourly demands for the period between 1 March 1993 and 31 March 1994. Based on 10 years of historical data, the peak electrical demand is clearly rising year to year. The rate of increase is fairly constant, at about 300 kW per year. The difference between base and peak loads has remained essentially constant.

Current and future construction activities for Base Relocation and Closure (BRAC) have been projected to increase electrical demand by about 7 MW. However, with about half the new construction completed now, only about 1.5 MW of the increased load has been realized. This may be explained by older building demolitions and relocation of equipment as new buildings are completed and occupied. Energy conservation measures currently under construction and several projects which have recently received funding will result in significant additional load reduction.

Feasibility evaluation of a power generation facility for Fort Huachuca must commence with a load study, considering current loads and all planned construction. For the purposes of this effort, a planning horizon of the year 2000 is selected. It is further assumed that the above considerations will increase electrical demand at the historical rate of about 300 kW per year. Thus, the projected electrical load for Fort Huachuca in the year 2000 is:

	<u>Base kW</u>	<u>Peak kW</u>	
Existing Loads	8,745	20,148	
Load Growth	<u>2,100</u>	<u>2,100</u>	(7 years at 300 kW/Year)
Projected Load	10,845	22,248	

#### 6.4.2 Electrical Demands for the City of Sierra Vista and Fort Huachuca

The city of Sierra Vista is supplied power from Sulfur Springs Valley Electrical Cooperative, Inc. (SSVEC). Limited data made available from SSVEC is as follows:

Electrical Demand:	20 to 25 MW
Monthly kWhs:	12 to 14 million
Load Factor:	60%

Sierra Vista is a rapidly growing city. Housing and commercial construction proceeds at a rapid pace. Load growth projections are not available; however, based on observation, the growth is expected to exceed that of Fort Huachuca. For the purposes of this evaluation, a future load of about 30,000 kW is assumed. Thus, the electric demands to be used in evaluations for Sierra Vista are:

	<u>Base kW</u>	<u>Peak kW</u>	
Existing Loads	15,000	25,000	
Load Growth	<u>5,000</u>	<u>5,000</u>	(7 years at 300 kW/Year)
Projected Load	20,000	30,000	

Total plant capacity is the sum of projected loads for Fort Huachuca and the City of Sierra Vista, as follows:

<u>Projected Load</u>	<u>Base kW</u>	<u>Peak kW</u>
Fort Huachuca	10,845	22,248
Sierra Vista	<u>20,000</u>	<u>30,000</u>
Total Projected Load	30,845	52,248

#### 6.4.3 Proposed Generating Plant Configurations

Based on application of Solar Turbines, Inc. gas turbine generator sets, the following configurations were used to determine the feasibility of Alternatives 2 and 3:

##### Alternative 2 - Fort Huachuca and City of Sierra Vista:

Peak Load: 4 x Mars 100 Gas Turbine/Generator Sets, with	29.6 MW
Duct Fired Heat Recovery Steam Turbine/Generator Set	24.1 MW
Internal Plant Load allowance	(1.5 MW)
Production: 52.2 MW	8,870 BTU/kWH Heat Rate



Base Load: 3 x Mars 100 Gas Turbine/Generator Sets, with	22.2 MW
Heat Recovery Steam Turbine/Generator Set (Not Fired), including losses	8.6 MW
Production: 30.8 MW	8,203 BTU/kWH Heat Rate

Alternative 3 - Fort Huachuca Only:

Peak Load: 2 X Mars 100 Gas Turbine/Generator Sets, with	14.8 MW
Duct Fired Heat Recovery Steam Turbine/Generator Set	7.9 MW
Internal Plant Load allowance	(0.5 MW)
Production: 22.2 MW	8,008 BTU/kWH Heat Rate

Base Load: 1 x Mars 100 Gas Turbine/Generator Set, with	7.9 MW
Duct Fired Heat Recovery Steam Turbine/Generator Set, including losses	2.9 MW
Production: 10.8 MW	8,292 BTU/kWH Heat Rate

**6.4.4 Results of Feasibility Analyses**

A summary of life-cycle cost analyses of Alternatives 2 and 3 appears in Table 6-2. Two cases were evaluated for each alternative: (1) power generation following the load and (2) power generation at maximum capacity with the excess wheeled through the grid to wholesalers. As shown, all four alternatives evaluated are economically viable.

Refer to Appendix J for detailed backup data and calculations.



Figure 6 - 1. Combined Cycle Cogeneration, PURPA Qualifying Facility Flow Diagram

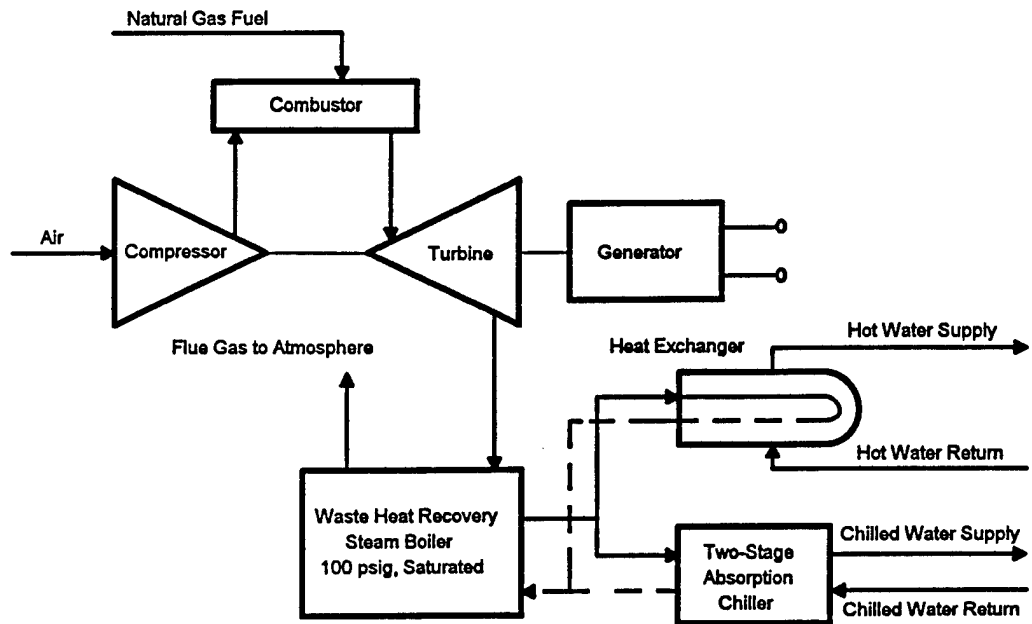
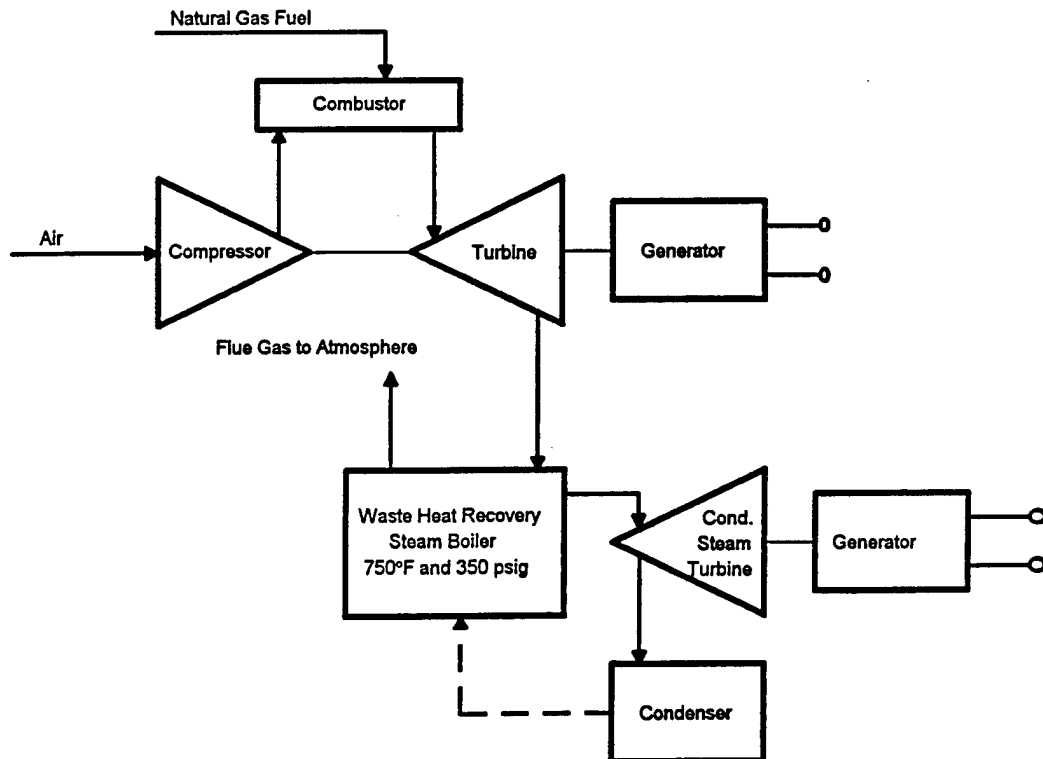
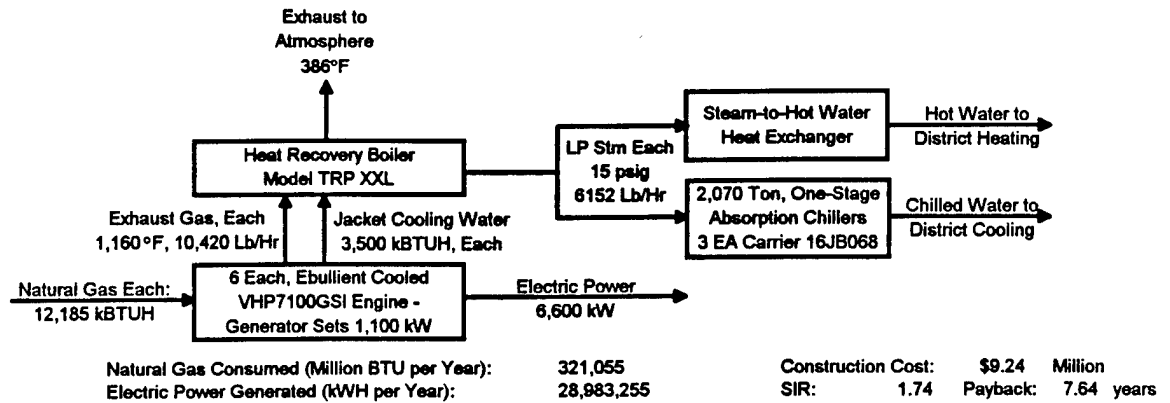

Figure 6 - 2. Combined Cycle Exempt Wholesale Generation Flow Diagram



**Figure 6-3. Cogeneration Alternative 1C1:  
Ebullient Cooled Engine Generator  
with Heat Recovery and Single Stage Absorption Chilling**



**Figure 6-4. Cogeneration Alternative 1C2:  
Gas Engine Generator  
with Exhaust Heat Recovery and Two Stage Absorption Chilling**

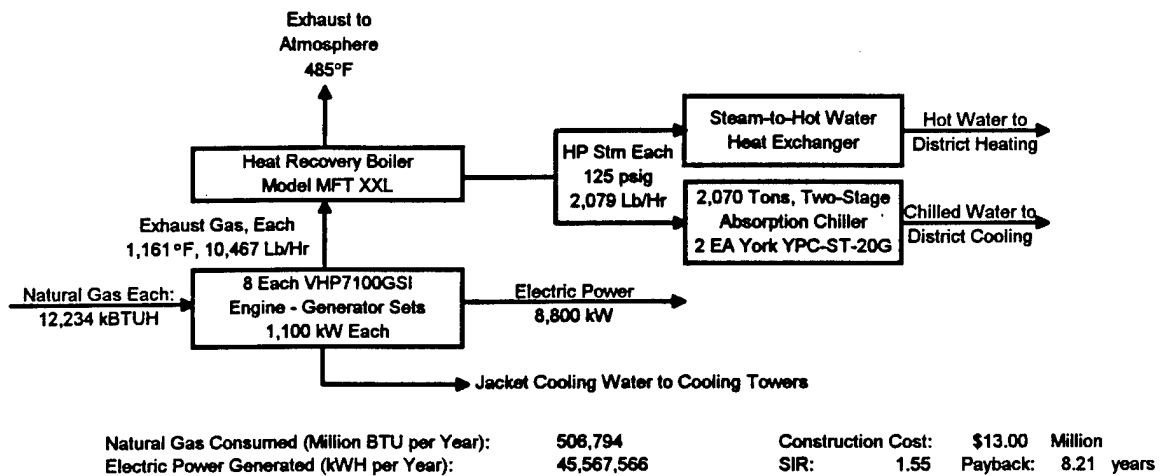

**Figure 6-5. Cogeneration Alternative 1C3:  
Ebullient Cooled Engine Generator  
with Exhaust and Jacket Heat Recovery, One & Two Stage Absorption Chilling**

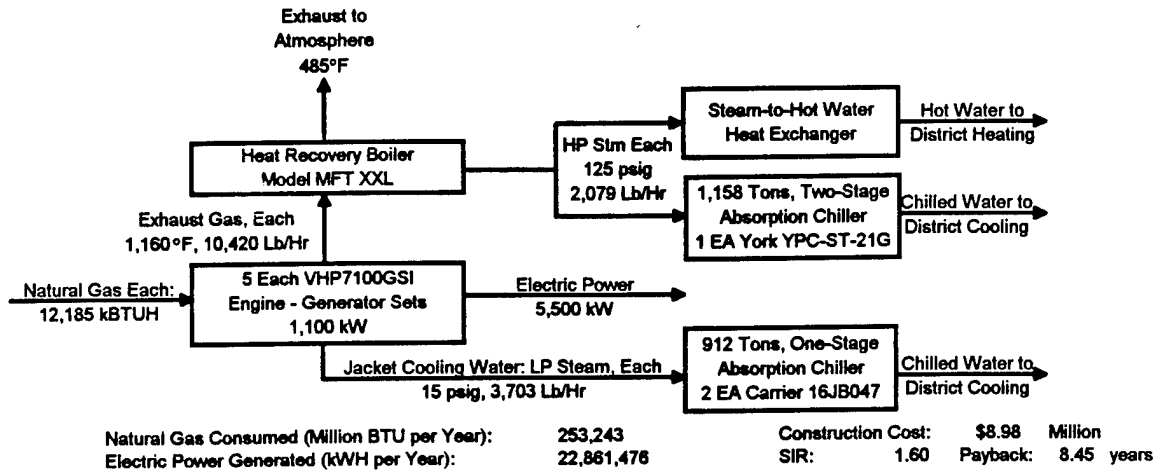

**Table 6-1  
Summary of Life Cycle Cost Analyses of Cogeneration Serving Central Heating/Cooling Plants**

Description of Cash Flow / Economic Measure	Gas Turbine-Generators and Absorption Chillers		Gas Engine-Generators and Absorption Chillers	
	South Plant Alternative 1A1	North Plant Alternative 1A2	Both Plants Alternative 1B	Both Plants Alternative 1C1
Generating Capacity (kW):	3,312	3,312	4,727	6,600
Construction Cost:	\$8,645,204	\$8,497,338	\$12,340,365	\$9,237,615
Investment per kW	\$9,682,629	\$9,517,018	\$13,821,209	\$10,346,129
	\$2,923	\$2,873	\$2,924	\$1,568
				\$1,654
				8,800
				\$12,999,342
				\$14,559,263
				\$1,829
				\$181,102
				\$333,631
				\$2,203,192
				\$264,505
				(\$885,599)
				\$1,397,941
				\$1,915,853
				\$181,102
				\$160,000
				(\$173,900)
				(\$15,631)
				(\$28,370)
				(\$141,775)
				\$4,348
				\$181,102
				\$333,631
				\$2,203,192
				\$264,505
				(\$885,599)
				\$1,397,941
				\$1,915,853
				\$181,102
				\$160,000
				(\$173,900)
				(\$15,631)
				(\$28,370)
				(\$141,775)
				\$4,348
				\$181,102
				\$333,631
				\$2,203,192
				\$264,505
				(\$885,599)
				\$1,397,941
				\$1,915,853
				\$181,102
				\$160,000
				(\$173,900)
				(\$15,631)
				(\$28,370)
				(\$141,775)
				\$4,348
				\$181,102
				\$333,631
				\$2,203,192
				\$264,505
				(\$885,599)
				\$1,397,941
				\$1,915,853
				\$181,102
				\$160,000
				(\$173,900)
				(\$15,631)
				(\$28,370)
				(\$141,775)
				\$4,348
				\$181,102
				\$333,631
				\$2,203,192
				\$264,505
				(\$885,599)
				\$1,397,941
				\$1,915,853
				\$181,102
				\$160,000
				(\$173,900)
				(\$15,631)
				(\$28,370)
				(\$141,775)
				\$4,348
				\$181,102
				\$333,631
				\$2,203,192
				\$264,505
				(\$885,599)
				\$1,397,941
				\$1,915,853
				\$181,102
				\$160,000
				(\$173,900)
				(\$15,631)
				(\$28,370)
				(\$141,775)
				\$4,348
				\$181,102
				\$333,631
				\$2,203,192
				\$264,505
				(\$885,599)
				\$1,397,941
				\$1,915,853
				\$181,102
				\$160,000
				(\$173,900)
				(\$15,631)
				(\$28,370)
				(\$141,775)
				\$4,348
				\$181,102
				\$333,631
				\$2,203,192
				\$264,505
				(\$885,599)
				\$1,397,941
				\$1,915,853
				\$181,102
				\$160,000
				(\$173,900)
				(\$15,631)
				(\$28,370)
				(\$141,775)
				\$4,348
				\$181,102
				\$333,631
				\$2,203,192
				\$264,505
				(\$885,599)
				\$1,397,941
				\$1,915,853
				\$181,102
				\$160,000
				(\$173,900)
				(\$15,631)
				(\$28,370)
				(\$141,775)
				\$4,348
				\$181,102
				\$333,631
				\$2,203,192
				\$264,505
				(\$885,599)
				\$1,397,941
				\$1,915,853
				\$181,102
				\$160,000
				(\$173,900)
				(\$15,631)
				(\$28,370)
				(\$141,775)
				\$4,348
				\$181,102
				\$333,631
				\$2,203,192
				\$264,505
				(\$885,599)
				\$1,397,941
				\$1,915,853
				\$181,102
				\$160,000
				(\$173,900)
				(\$15,631)
				(\$28,370)
				(\$141,775)
				\$4,348
				\$181,102
				\$333,631
				\$2,203,192
				\$264,505
				(\$885,599)
				\$1,397,941
				\$1,915,853
				\$181,102
				\$160,000
				(\$173,900)
				(\$15,631)
				(\$28,370)
				(\$141,775)
				\$4,348
				\$181,102
				\$333,631
				\$2,203,192
				\$264,505
				(\$885,599)
				\$1,397,941
				\$1,915,853
				\$181,102
				\$160,000
				(\$173,900)
				(\$15,631)
				(\$28,370)
				(\$141,775)
				\$4,348
				\$181,102
				\$333,631
				\$2,203,192
				\$264,505
				(\$885,599)
				\$1,397,941
				\$1,915,853
				\$181,102
				\$160,000
				(\$173,900)
				(\$15,631)
				(\$28,370)
				(\$141,775)
				\$4,348
				\$181,102
				\$333,631
				\$2,203,192
				\$264,505
				(\$885,599)
				\$1,397,941
				\$1,915,853
				\$181,102
				\$160,000
				(\$173,900)
				(\$15,631)
				(\$28,370)
				(\$141,775)
				\$4,348
				\$181,102
				\$333,631
				\$2,203,192
				\$264,505
				(\$885,599)
				\$1,397,941
				\$1,915,853
				\$181,102
				\$160,000
				(\$173,900)
				(\$15,631)
				(\$28,370)
				(\$141,775)
				\$4,348
				\$181,102
				\$333,631
				\$2,203,192
				\$264,505
				(\$885,599)
				\$1,397,941
				\$1,915,853
				\$181,102
				\$160,000
				(\$173,900)
				(\$15,631)
				(\$28,370)
				(\$141,775)
				\$4,348
				\$181,102
				\$333,631
				\$2,203,192
				\$264,505
				(\$885,599)
				\$1,397,941
				\$1,915,853
				\$181,102
				\$160,000
				(\$173,900)
				(\$15,631)
				(\$28,370)
				(\$141,775)
				\$4,348
				\$181,102
				\$333,631
				\$2,203,192
				\$264,505
				(\$885,599)
				\$1,397,941
				\$1,915,853
				\$181,102
				\$160,000
				(\$173,900)
				(\$15,631)
				(\$28,370)
				(\$141,775)
				\$4,348
				\$181,102
				\$333,631
				\$2,203,192
				\$264,505
				(\$885,599)
				\$1,397,941
				\$1,915,853
				\$181,102
				\$160,000
				(\$173,900)
				(\$15,631)
				(\$28,370)
				(\$141,775)
				\$4,348
				\$181,102
				\$333,631
				\$2,203,192
				\$264,505
				(\$885,599)
				\$1,397,94

**Table 6-2.**  
**Summary of Life Cycle Cost Analyses of Power Generation Serving Fort Huachuca and Sierra Vista**

<u>Description of Cash Flow / Economic Measure</u>	<u>Alternative 2</u>	<u>Alternative 3</u>	<u>Alt 2 Max</u>	<u>Alt 3 Max</u>
Generating Capacity (kW):	52,248	22,248	52,248	22,248
Construction Cost:	\$50,549,415	\$34,120,962	\$50,549,415	\$34,120,962
Investment:	\$56,615,344	\$38,215,478	\$56,615,344	\$38,215,478
Investment per kW	\$1,084	\$1,718	\$1,084	\$1,718
<b>Power Sales Revenues:</b>				
Fort Huachuca (\$/Year):	\$7,447,034	\$7,447,034	\$7,447,034	\$7,447,034
Sierra Vista (\$/Year):	\$10,211,615	\$0	\$10,211,615	\$0
Power Grid (\$/Year):	\$0	\$0	\$5,106,656	\$2,562,252
<b>Total Power Sales (\$/Year):</b>	<b>\$17,658,649</b>	<b>\$7,447,034</b>	<b>\$22,765,305</b>	<b>\$10,009,285</b>
<b>Standby Power Costs (to provide service to Sierra Vista and Fort Huachuca during plant outages)</b>				
Standby Service (\$/Year):	(\$136,570)	(\$53,177)	(\$136,570)	(\$53,177)
Standby Power Use (\$/Year):	(\$114,357)	(\$44,528)	(\$114,357)	(\$44,528)
<b>Total Standby Cost (\$/Year)</b>	<b>(\$250,927)</b>	<b>(\$97,706)</b>	<b>(\$250,927)</b>	<b>(\$97,706)</b>
Standby Service Costs 1st Year:	(\$1,503,122)	(\$585,284)	(\$1,503,122)	(\$585,284)
<b>Annual Operation &amp; Maintenance (\$/Year):</b>	<b>(\$1,237,129)</b>	<b>(\$481,712)</b>	<b>(\$1,799,860)</b>	<b>(\$766,408)</b>
<b>Economic Evaluation Measures:</b>				
Simple Payback Period (Years):	6.24	9.19	5.88	7.83
Total Net Discounted Savings (\$)	\$112,307,533	\$53,298,768	\$106,739,162	\$58,863,574
Savings to Investment Ratio:	1.98	1.39	1.89	1.54
<b>Alternatives Investigated Include:</b>				
Alternative 2	Facility serving Fort Huachuca and Sierra Vista. Power generation matching load.			
Alternative 3	Facility serving Fort Huachuca only. Power generation matching load.			
Alternative 2 Max	Facility serving Fort Huachuca and Sierra Vista. Power generation at maximum capacity.			
Alternative 3 Max	Facility serving Fort Huachuca only. Power generation at maximum capacity.			

**APPENDIX A**

**Scope of Work and Minutes of Project Meetings**

SCOPE OF WORK  
FOR AN  
ENERGY SAVINGS OPPORTUNITY SURVEY (ESOS)

TABLE OF CONTENTS

1. BRIEF DESCRIPTION OF WORK
2. GENERAL
3. PROJECT MANAGEMENT
4. SERVICES AND MATERIALS
5. PROJECT DOCUMENTATION
  - 5.1 ECIP Projects
  - 5.2 Non-ECIP Projects
  - 5.3 Nonfeasible ECOs
6. DETAILED SCOPE OF WORK
7. WORK TO BE ACCOMPLISHED
  - 7.1 Review Previous Studies
  - 7.4 Perform a Limited Site Survey
  - 7.3 Reevaluate Selected Projects
  - 7.4 Evaluate New ECOs
  - 7.5 Provide Programming or Implementation Documentation
  - 7.6 Submittals, Presentations and Reviews

ANNEXES

- A - GENERAL ENERGY CONSERVATION OPPORTUNITIES
- B - DETAILED SCOPE OF WORK
- C - REQUIRED DD FORM 1391 DATA
- D - EXECUTIVE SUMMARY GUIDELINE

1. BRIEF DESCRIPTION OF WORK: The Architect-Engineer (AE) shall:

1.1 Review for general information the previously completed Energy Engineering Analysis Program (EEAP) study and any other energy studies which were performed at this installation.

1.2 Perform a limited site survey of selected buildings or areas to insure that any methods of energy conservation which are practical and have not been evaluated in any previous energy study have been considered and the results documented.

1.3 Reevaluate selected projects and energy conservation opportunities (ECOs) from the previous studies to determine their economic feasibility based on revised criteria, current site conditions and technical applicability.

1.4 Evaluate selected ECOs to determine their energy savings potential and economic feasibility.

1.5 Provide complete programming or implementation documentation for all recommended ECOs.

1.6 Prepare a comprehensive report to document the work performed, the results and the recommendations.

2. GENERAL

2.1 Other studies performed under the EEAP have been performed at this installation. Criteria for both the study and the resulting documentation has changed since the previous study was completed. This study is intended to reevaluate selected projects from the previous study which have not been implemented nor programmed for implementation and to consider specific ECOs in buildings and areas that may have been overlooked previously or recently identified.

2.2 The information and analysis outlined herein are considered to be minimum essentials for adequate performance of this study.

2.3 The AE shall ensure that all methods of energy conservation which will reduce the energy consumption of the installation in compliance with the Energy Resources Management Plan including those listed in Annexes A and B have been considered and documented. All methods of energy conservation which are reasonable and practical shall be considered, including improvements of operational methods and procedures as well as the physical facilities. All energy conservation opportunities which produce energy or dollar savings shall be documented in this report. Any energy conservation opportunity considered infeasible shall also be documented in the report with reasons for elimination. A list of general energy conservation opportunities to be used when evaluating specific buildings or areas is included as Annex A to this scope. Annex B contains a list of ECOs specifically for this installation. Both of these lists shall be

considered and the evaluation of each ECO documented in the report. These lists are not intended to be restrictive but only to assure that basic and generally repetitive opportunities are addressed in the report. The AE may be aware of other ECOs not included in Annex A or Annex B that will produce energy, manpower or dollar savings. These should be evaluated the same as the listed ECOs. Some of the energy conservation opportunities in Annex A may not be applicable to the specific building or area at this installation. A statement to that effect is all that is required.

2.4 The study shall include the energy consuming buildings or areas listed in Annex B. The work in the areas may be reduced somewhat by building repetition.

2.5 The study shall consider the use of all energy sources. The energy sources may include electricity, natural gas, liquefied petroleum gas, bulk oil, other oil products, steam when procured, gasoline, coal, solar, etc.

2.6 The "Energy Conservation Investment Program (ECIP) Guidance", described in letter from CEHSC-FU, dated 4 November 1992, establishes criteria for ECIP projects and shall be used for performing the economic analyses of all ECOs and projects. Construction cost escalation for DD Form 1391 submission shall be calculated using the guidelines contained in AR 415-17 and the latest Tri-Service MCP Index. The Tri-Service MCP Index, when updated, is contained in the latest applicable edition of the Engineer Improvement Recommendation System (EIRS) bulletin.

2.7 Computer modeling will be used to determine the energy savings of ECOs which would replace or significantly change an existing heating, ventilating, and air-conditioning (HVAC) system. The requirement to use computer modeling applies only to heated and air-conditioned or air-conditioned-only buildings which exceed 8,000 square feet or heated-only buildings in excess of 20,000 square feet. Modeling will be done using a professionally recognized and proven computer program or programs that integrate architectural features with air-conditioning, heating, lighting and other energy-producing or consuming systems. These programs will be capable of simulating the features, systems, and thermal loads of the building under study. The program will use established weather data files and may perform calculations on a true hour-by-hour basis or may condense the weather files and the number of calculations into several "typical" days per month. The Detailed Scope of Work, Annex B, will list programs that are acceptable to the Contracting Officer. If the AE desires to use a different program, it must be submitted for approval with a sample run, an explanation of all input and output data, and a summary of program methodology and energy evaluation capabilities.

2.8 Energy conservation opportunities determined to be technically and economically feasible shall be developed into projects acceptable to installation personnel. This may involve combining similar ECOs into larger packages which will qualify for ECIP or

MCA funding, and determining, in coordination with installation personnel, the appropriate packaging and implementation approach for all feasible ECOs.

2.8.1 Projects which qualify for ECIP funding shall be identified, separately listed, and prioritized by the Savings to Investment Ratio (SIR).

2.8.2 All feasible non-ECIP projects shall be ranked in order of highest to lowest SIR.

2.8.3 At some installations Energy Conservation and Management (ECAM) funding will be used instead of ECIP funding. The criteria for each program is the same. The Director of Engineering and Housing will indicate which program is used at this installation. This Scope of Work mentions only ECIP, however, ECAM is also meant.

### 3. PROJECT MANAGEMENT

3.1 Project Managers. The AE shall designate a project manager to serve as a point of contact and liaison for work required under this contract. Upon award of this contract, the individual shall be immediately designated in writing. The AE's designated project manager shall be approved by the Contracting Officer prior to commencement of work. This designated individual shall be responsible for coordination of work required under this contract. The Contracting Officer will designate a project manager to serve as the Government's point of contact and liaison for all work required under this contract. This individual will be the Government's representative.

3.2 Installation Assistance. The Commanding Officer at each installation will designate an individual who will serve as the point of contact for obtaining information and assisting in establishing contacts with the proper individuals and organizations as necessary to accomplish the work required under this contract.

3.3 Public Disclosures. The AE shall make no public announcements or disclosures relative to information contained or developed in this contract, except as authorized by the Contracting Officer.

3.4 Meetings. Meetings will be scheduled whenever requested by the AE or the Contracting Officer for the resolution of questions or problems encountered in the performance of the work. The AE and/or the designated representative(s) shall be required to attend and participate in all meetings pertinent to the work required under this contract as directed by the Contracting Officer. These meetings, if necessary, are in addition to the presentation and review conferences.

3.5 Site Visits, Inspections, and Investigations. The AE shall visit and inspect/investigate the site of the project as necessary and required during the preparation and accomplishment

of the work.

### 3.6 Records

3.6.1 The AE shall provide a record of all significant conferences, meetings, discussions, verbal directions, telephone conversations, etc., with Government representative(s) relative to this contract in which the AE and/or designated representative(s) thereof participated. These records shall be dated and shall identify the contract number, and modification number if applicable, participating personnel, subject discussed and conclusions reached. The AE shall forward to the Contracting Officer within ten calendar days, a reproducible copy of the records.

3.6.2 The AE shall provide a record of requests for and/or receipt of Government-furnished material, data, documents, information, etc., which if not furnished in a timely manner, would significantly impair the normal progression of the work under this contract. The records shall be dated and shall identify the contract number and modification number, if applicable. The AE shall forward to the Contracting Officer within ten calendar days, a reproducible copy of the record of request or receipt of material.

3.7 Interviews. The AE and the Government's representative shall conduct entry and exit interviews with the Director of Engineering and Housing before starting work at the installation and after completion of the field work. The Government's representative shall schedule the interviews at least one week in advance.

3.7.1 Entry. The entry interview shall describe the intended procedures for the survey and shall be conducted prior to commencing work at the facility. As a minimum, the interview shall cover the following points:

- a. Schedules.
- b. Names of energy analysts who will be conducting the site survey.
- c. Proposed working hours.
- d. Support requirements from the Director of Engineering and Housing.

3.7.2 Exit. The exit interview shall briefly describe the items surveyed and probable areas of energy conservation. The interview shall also solicit input and advice from the Director of Engineering and Housing.

4. SERVICES AND MATERIALS. All services, materials (except those specifically enumerated to be furnished by the Government), plant, labor, superintendence and travel necessary to perform the work

and render the data required under this contract are included in the lump sum price of the contract.

5. PROJECT DOCUMENTATION. All energy conservation opportunities which the AE has considered shall be included in one of the following categories and presented in the report as such:

5.1 ECIP Projects. To qualify as an ECIP project, an ECO, or several ECOs which have been combined, must have a construction cost estimate greater than \$300,000, a Savings to Investment Ratio greater than one and a simple payback period of less than ten years. For ECAM projects, the \$300,000 limitation may not apply; in such cases, the AE shall check with the installation for guidance. The overall project and each discrete part of the project shall have an SIR greater than one. For all projects meeting the above criteria, complete programming documentation shall be required. Programming documentation shall consist of a DD Form 1391, life cycle cost analysis (LCCA) summary sheet(s) (with necessary backup data to verify the numbers presented), and a Project Development Brochure (PDB). A life cycle cost analysis summary sheet shall be developed for each ECO and for the overall project when more than one ECO are combined. The energy savings for projects consisting of multiple ECOs must take into account the synergistic effects of the individual ECOs. For projects and ECOs reevaluated from previous studies, the backup data shall consist of copies of the original calculations and analysis, with new pages revising the original calculations and analysis. In addition, the backup data shall include as much of the following as is available: the increment of work under which the project or ECO was developed in the previous study, title(s) of the project(s), the energy to cost (E/C) ratio, the benefit to cost (B/C) ratio, the current working estimate (CWE), and the payback period. The purpose of this information is to provide a means to prevent duplication of projects in any future reports.

5.2 Non-ECIP Projects. Projects which do not meet ECIP criteria with regard to cost estimate or payback period, but which have an SIR greater than one shall be documented. Projects or ECOs in this category shall be provided with the following documentation: the life cycle cost analysis (LCCA) summary sheet completely filled out, a description of the work to be accomplished, backup data for the LCCA, ie, energy savings calculations and cost estimate(s), and the simple payback period. The energy savings for projects consisting of multiple ECOs must take into account the synergistic effects of the individual ECOs. In addition these projects shall have the necessary documentation prepared, as required by the Government's representative, for one of the following categories:

a. Quick Return on Investment Program (QRIP). This program is for projects which have a total cost greater than \$3,000 but less than \$100,000 and a simple payback period of two years or less.

b. Productivity Enhancing Capital Investment Program (PE-CIP). This program is for projects which have a total cost of greater than \$3,000 but less than \$100,000 and a simple payback period of four years or less.

c. OSD Productivity Investment Funding (OSD PIF). This program is for projects which have a total cost of more than \$100,000 and a simple payback period of four years or less.

The above programs and the required documentation forms are all described in detail in AR 5-4, Change No. 1.

d. Regular Military Construction Army (MCA) Program. This program is for projects which have a total cost greater than \$300,000 and a simple payback period of four to twenty-five years. Documentation shall consist of DD Form 1391 and a Project Development Brochure.

e. Low Cost/No Cost Projects. These are projects which the Director of Engineering and Housing (DEH) can perform using his resources. Documentation shall be as required by the DEH.

5.3 Nonfeasible ECOs. All ECOs which the AE has considered but which are not feasible, shall be documented in the report with reasons and justifications showing why they were rejected.

6. DETAILED SCOPE OF WORK. The general Scope of Work is intended to apply to contract efforts for all Army installations included under this contract except as modified by the detailed Scope of Work for each individual installation. The detailed Scope of Work is contained in Annex B.

7. WORK TO BE ACCOMPLISHED.

7.1 Review Previous Studies. The AE shall review for general information the previous EEAP study along with any other energy studies performed at the installation. This review should acquaint the AE with the work that has been performed previously. Much of the information the AE may need to develop the ECOs in this project will be contained in the previous studies. The survey data contained in the previous study should be very helpful to the results of this study.

7.2 Perform a Limited Site Survey. The AE shall obtain all necessary data to evaluate the ECOs or projects by conducting a site survey. However, the AE is encouraged to use any data that may have been documented in a previous study. The AE shall document his site survey on forms developed for the survey, or standard forms, and submit these completed forms as part of the report. All test and/or measurement equipment shall be properly calibrated prior to its use.

7.3 Reevaluate Selected Projects. The AE shall reevaluate the projects and ECOs listed in Annex B. These projects and ECOs are projects and ECOs that the previous study has identified but that have not been accomplished or only parts have been accomplished. If the project or ECO is acceptable as is, that is, there are no changes to the basic project or ECO, the energy savings shown in the previous project may be accepted as accurate but the energy cost and construction cost estimates shall be updated based on the most current data available. With the above information the project shall then be analyzed based on current ECIP criteria. If the project or ECO is basically acceptable but some of the buildings in the original project have been deleted or new buildings can be added, the necessary changes shall be made to the energy savings, the energy costs and construction costs shall be updated and the revised project or ECO shall then be analyzed using current ECIP guidance. If the original project or ECO has had numerous changes made to it so that all of the numbers are suspected of being inaccurate, but the project or ECO is still considered feasible, the AE shall develop the project from the beginning and analyze it with the current ECIP guidance. These projects shall be separately listed in the report.

7.4 Evaluate New ECOs. These ECOs shall be analyzed in detail to determine their feasibility. Savings to Investment Ratios (SIRs) shall be determined using current ECIP guidance. The AE shall provide all data and calculations needed to support the conclusions. All assumptions shall be clearly stated. Calculations shall be prepared showing how all numbers in the ECO were figured. Calculations shall be an orderly step-by-step progression from the first assumption to the final number. Descriptions of the products, manufacturers catalog cuts, pertinent drawings and sketches shall also be included. A life cycle cost analysis summary sheet shall be prepared for each ECO and included as part of the supporting data. The following classes of ECOs are included:

a. General ECOs: The list of ECOs in Annex A shall be evaluated for the buildings or areas listed in Annex B. Those items on the list which are not practical, have been previously accomplished, are inappropriate or can be eliminated from detailed analysis based on preliminary analysis shall be listed in the report along with the reason for elimination from further analysis. All potential ECOs which are not eliminated by preliminary considerations shall be thoroughly documented and evaluated as to technical and economic feasibility.

b. Selected ECOs: These are the specific ECOs which are listed in Annex B.

c. Contractor-identified ECOs: These are those ECOs which the AE is aware of or notes during the field survey that are not included in Annex A or Annex B but will produce energy, manpower or dollar savings. These should be evaluated the same as the listed ECOs.

7.5 Provide Programming or Implementation Documentation. During the Interim Review Conference, as outlined in paragraph 7.6.1, the AE will be advised of the DEH's preferred packaging of recommended ECOs into projects for implementation. These projects will be documented as outlined in paragraphs 5.1, 5.2, and 5.3. Programming documentation will be included in the Prefinal Submittal per par 7.6.2. Programming documents shall be separate from the narrative report, and they shall be bound similarly to the final report in a manner which will facilitate repeated disassembly and reassembly.

7.6 Submittals, Presentations and Reviews. The work accomplished shall be fully documented by a comprehensive report. The report shall have a table of contents and be indexed. Tabs and dividers shall clearly and distinctly divide sections, sub-sections, and appendices. All pages shall be numbered. The AE shall give a formal presentation of all but the final submittal to installation, command, and other Government personnel. The AE shall prepare slides or view graphs showing the results of the study to date for his presentation. During the presentation, the personnel in attendance shall be given ample opportunity to ask questions and discuss any changes deemed necessary to the study. A review conference will be conducted the same day, following the presentation. Each comment presented at the review conference will be discussed and resolved or action items assigned. The AE shall provide the comments from all reviewers and written notification of the action taken on each comment to all reviewing agencies within three weeks after the review meeting. It is anticipated that each presentation and review conference will require approximately one working day. The presentation and review conferences will be at the installation on the date(s) agreeable to the Director of Engineering and Housing, the AE and the Government's representative. The Contracting Officer may require a resubmittal of any document(s), if such document(s) are not approved because they are determined by the Contracting Officer to be inadequate for the intended purpose.

7.6.1 Interim Submittal. An interim report shall be submitted for review after completion of the field survey and an analysis has been performed on all of the ECOs. The report shall indicate the work which has been accomplished to date, illustrate the methods and justifications of the approaches taken and contain a plan of the work remaining to complete the study. Calculations showing energy and dollar savings and SIRs of all the ECOs shall be included. The simple payback period of all ECOs shall be calculated and shown in the report. The AE shall submit the Scope of Work and any modifications to the Scope of Work as an appendix to the report. A narrative summary describing the work and results to date shall be a part of this submittal. During the review period, the Government's representative shall coordinate with the Director of Engineering and Housing and provide the AE with direction for packaging or combining ECOs for programming purposes and also indicate the fiscal year for which the programming or implementation documentation shall be prepared. A sample implementation document (DA Form 5108-R, sketches and

manufacturers data, life cycle cost analysis summary sheet and supporting data) for one project shall be submitted with this submittal for review and approval. The survey forms completed during this audit shall be submitted with this report. The survey forms only may be submitted in final form with this submittal. They should be clearly marked at the time of submission that they are to be retained. They shall be bound in a standard three-ring binder which will allow repeated disassembly and reassembly of the material contained within.

7.6.2 Prefinal Submittal. The AE shall prepare and submit the prefinal report when all work under this contract is complete. The AE shall submit the Scope of Work for the installation studied and any modifications to the Scope of Work as an appendix to the submittal. The report shall contain a narrative summary of conclusions and recommendations, together with all raw and supporting data, methods used, and sources of information. The report shall integrate all aspects of the study. The report shall include an order of priority by SIR in which the recommended ECOs should be accomplished. The synergistic effects of all of the ECOs on one another shall have been determined and the results of the original calculations adjusted accordingly. Completed programming and implementation documents for all recommended projects shall be included. The programming and implementation documents shall be ready for review and signature by the installation commander. The prefinal report, separately bound Executive Summary and all appendices shall be bound in standard three-ring binders which will allow repeated disassembly and reassembly. The prefinal submittal shall be arranged to include (a) a separately bound Executive Summary to give a brief overview of what was accomplished and the results of this study using graphs, tables and charts as much as possible (See Annex D for minimum requirements), (b) the narrative report containing a copy of the Executive Summary at the beginning of the volume and describing in detail what was accomplished and the results of this study, (c) appendices to include the detailed calculations and all backup material and (d) the programming and implementation documentation. A list of all projects and ECOs developed during this study shall be included in the Executive Summary and shall include the following data from the life cycle cost analysis summary sheet: the cost (construction plus SIOH), the annual energy savings (type and amount), the annual dollar savings, the SIR, the simple payback period and the analysis date. For all programmed projects also include the year in which it is programmed and the programmed year cost.

7.6.3 Final Submittal. Any revisions or corrections resulting from comments made during the review of the prefinal report or during the presentation and review conference shall be incorporated into the final report. These revisions or corrections may be in the form of replacement pages, which may be inserted in the prefinal report, or complete new volumes. Pen and ink changes or errata sheets will not be acceptable. If replacement pages are to be issued, it shall be clearly stated with the prefinal submittal that the submitted documents will be changed

only to comply with the comments made during the prefinal conference and that the volumes issued at the time of the prefinal submittal should be retained. Failure to do so will require resubmission of complete volumes. If new volumes are submitted, they shall be in standard three-ring binders and shall contain all the information presented in the prefinal report with any necessary changes made. Detailed instructions of what to do with the replacement pages should be securely attached to the replacement pages.

CESPK-ED-M (415-10f)

8 April 1994  
DSOWESFH/AA2Jwin  
FILE  
CONTRACT  
16-403-13

## SUPPLEMENTAL SCOPE OF WORK

SUBJECT: FY93 Energy Engineering Analysis Program (EEAP), Energy Savings Opportunity Survey (ESOS), Fort Huachuca, AZ

CONTRACT NO. DACA05-92-C-0155

A-E ADDRESS: Keller and Gannon  
1453 Mission Street  
San Francisco, California

POINTS OF CONTACT: Messrs. Richard Lennig/Blair Horst

PHONE NO: (415) 621-1199

FAX NO: (415) 864-3681

1. Project Data:

1.1 Installation and Location: Fort Huachuca, Arizona

1.2 Study Title: Energy Savings Opportunity Survey (ESOS) Study

1.3 Project No. 081

1.4 Authorization: TCR dated 7 April 1994, Subject: EEAP, ESOS Fort Huachuca, AZ.

1.5 Reference Supplemental Scope of Work dated (R) 25 January 1994, Subject: FY 93 Energy Engineering Analysis Program (EEAP), Energy Savings Opportunity Survey (ESOS), Fort Huachuca, AZ

2. Project Description/Services:

2.1 Energy Savings Opportunity Survey (ESOS) Study as specified in reference.

2.2 The reference Supplemental Scope of Work (SSOW) is revised as noted below:

a. Delete work and services specified in paragraphs 3.1, 3.3, 5.6, 5.7, and 5.8 of reference SSOW.

b. Delete Annex F (building list) in its entirety.

c. Delete options 2 and 3. The work specified in paragraphs 3.4 and 3.5 shall be performed under the basic contract requirement instead.

d. Delete the following items and/or buildings from Annex E list.

1) Item 12, Building 61801 (Admin., Computer Electronics Bldg).

2) Item 18, Building 90201 (Laundry)

3) Item 22, Building 907XX (Sewage Treatment Plant).

e. Paragraph 3.6 (Option 4), line 3, second sentence:  
Change "two weeks" to "four hours".

3. All requirements and criteria specified in reference SSOW remain unchanged except as noted hereinbefore.

  
NATHANIEL HUNTER  
Technical Manager

**DISTRIBUTION:**

A-B: Keller and Gannon (Mr. Lennig/Mr. Horst)

DEH: ATZS-EH-E (Mr. William Stein)

COE: CESAM-EN-CC (Mr. Battaglia)

COB: CESPDM-M

CESPK-ED-M (415-10f)

23 August 1993  
(R) 13 September 1993  
(R) 25 January 1994  
(R) 27 January 1994

DSOWESFH/AA2

SUPPLEMENTAL SCOPE OF WORK

SUBJECT: FY93 Energy Engineering Analysis Program (EEAP), Energy Savings Opportunity Survey (ESOS), Fort Huachuca, AZ

CONTRACT NO. DACA05-92-C-0155

A-E ADDRESS: Keller and Gannon ,  
1453 Mission Street  
San Francisco, California

POINTS OF CONTACT: Messrs. Richard Lennig/Blair Horst

PHONE NO: (415) 621-1199

FAX NO: (415) 864-3681

1. Project Data:

1.1 Installation and Location: Fort Huachuca, Arizona

1.2 Study Title: Energy Savings Opportunity Survey (ESOS) Study

1.3 Project No. 081

1.4 Authorization: CEMP-ET memorandum dated 25 Nov 92,  
Subject: Energy Engineering Analysis Program (EEAP) - FY93 Program.

2. Project Description/Services:

2.1 Energy Savings Opportunity Survey (ESOS) Study: The work and services for this project require an energy survey, evaluation and analyses of selected facilities, systems, equipment, and operations; and the feasibility of cogeneration. The General Scope of Work (GSOW) describes and specifies the general requirements and procedures for conducting, documenting the findings and, preparation of the study report.

2.2 This Supplemental Scope of Work (SSOW) supplements the GSOW by identifying specific facilities, sites, equipment, and systems to be investigated and/or studied. Should there be a conflict between the GSOW and this SSOW, the SSOW shall govern.

3. Evaluation and Survey of Projects and Energy Conservation Opportunities (ECO's):

3.1 Conduct an energy audit and survey for the buildings listed

in Annex F for the applicable ECO's listed in Annex A.

3.2 Evaluate the specific ECO's identified for the buildings listed in ANNEX E.

3.3 Review the FY81 Basewide EEAP Study and identify and update those potential ECO's that were not implemented but still remain valid (assume three ECO's require updating).

3.4 Option 1: Conduct an energy audit and survey for the buildings listed in Annex G for the applicable ECO's listed in Annex A.

3.4 Option 2: Conduct an economic analysis to determine feasibility of the following:

a. Cogeneration facility to serve existing central boiler/chiller plant (new), Building 81504 and the existing south boiler/chiller plant, Building 62701 (now programmed for immediate future expansion).

b. Cogeneration facility with ample capacity to supply electric power required for both Fort Huachuca and the adjacent city of Sierra Vista.

c. Cogeneration facility to serve Fort Huachuca and would qualify under the Public Utility Regulatory Policy Act (PURDA) of 1978 and/or as an Exempt Wholesale Generator (EWG) as defined in the Energy Policy Act of 1992.

3.5 Option 3: Monitor the harmonic distortion at the main distribution panel in the five buildings with the largest percentage of nonlinear loads. Each panel shall be monitored a minimum of two weeks. The monitoring will be conducted to determine whether harmonic filters are required at sensitive equipment locations due to retrofits such as electronic ballasts and variable frequency drives that generate additional harmonic distortion of the current and voltage wave forms.

3.6 Option 4, Document Review: Review existing PURPA & EWG policy and criteria, standards, etc., and prepare a summary report outlining procedures and design criteria required for compliance with policy and standards.

3.7 Option 5, EMCS Expansion:

3.7.1 Perform a preliminary screening (evaluation) of fifty (50) existing facilities to determine their potential for inclusion in the EMCS expansion study. The facilities selected for screening shall be done in coordination with the Fort Huachuca Energy Coordinator. The screening procedures shall identify those buildings with the greatest potential for integration into an existing (now under design) EMCS. The results of the screening shall be documented in a separate letter report. Six copies of the letter report shall be submitted to the

District project manager forty five (45) calendar days after receipt of Notice to Proceed (NTP) for the option.

3.7.2 Perform an ECO analysis to expand the existing EMCS to serve buildings identified in above screening process (assume forty buildings pass the screening test).

**NOTES:**

1) The FY91 EMCS ECIP project includes 14 buildings (Buildings 22208, 22422, 48101, 49013, 52030, 56301, 57305, 61610, 61701, 61801, 63845) and is to be advertised for construction in FY94. The A-E shall assume for the purpose of this study that the EMCS installation will be under construction during the study and fully operational by October 1994.

2) A-E's travel and per diem shall be identified separately for each option.

4. Programming Documents: Coordinate and prepare programming documents for feasible ECO's as specified in the GSOW. The ECO's shall be combined and package in programming documents as specified by the user (DEH). (Assume two (2) set of programming documents will be prepared under the basis study, and one (1) each under option 1 and option 7).

5. Submittals and Periods of Service:

5.1 Interim Report: The interim report is due one hundred fifty (150) calendar days after receipt of the Notice to Proceed (NTP). The interim report format and presentation shall be as specified in the GSOW.

5.2 Prefinal Report: The prefinal report is due seventy five (75) calendar days after the interim report review conference. The prefinal submittal shall conform with the requirements in the GSOW.

5.3 Final Report: The final report submittal shall be provided in accordance with requirements in the GSOW. The final report is due sixty (60) calendar days after the prefinal report review conference.

5.4 Review conferences will be as specified in the GSOW and will be held at the installation. A prestudy conference will be held to discuss and summarize survey data obtained during the field investigations with the installation staff to develop guidance and a consensus for assessing, organizing, and preparing the interim report. Two A-E representatives will attend each review conference specified above.

5.5 Option 1, Energy Audit and Survey:  
submittal periods shall be established at time option is exercised.

5.6 Option 2: The cogeneration economic analysis and feasibility study/report is due one hundred sixty days after exercise of option.

5.7 Option 3: Monitoring and harmonic distortion result shall be submitted forty five (45) calendar days after exercise of option.

5.8 Option 4, Document Review: The summary report shall be submitted forty (40) calendar days after exercise of option.

5.9 Option 5, EMCS Expansion: The draft letter report shall be submitted forty five (45) calendar days after exercise of option. Corrected documents shall be submitted within fourteen (14) days after receipt of review comments.

6. Points of Contact: Points of contact during the study are as noted below:

6.1 Mr. William Stein, DEH Energy Coordinator, Fort Huachu, AZ, (602) 533-1861.

6.2 Mr. Tony Battaglia, CESAM-EN-CM, Mobile District Mobile, AL, (205) 690-2618

6.3 Messrs. Richard C. Lennig or Blair Horst, Keller and Gannon (A-E), San Francisco, CA, 94142-2430

6.4 Mr. Nathaniel Hunter, CESPCK-ED-M/ISS), Sacramento District, Sacramento, CA, (916) 557-7413.

7. Numbers of Copies and Distribution: The numbers of copies and distribution of same shall be as specified below:

7.1 CDR, HQUSACE, ATTN: CEMP-ET (Mr. Dan Gentil), Washington D.C 20314-1000 - One (1) copy, final submittal Executive Summary only.

7.2 CDR, US Army Training and Doctrine Command, ATTN: LOEA-PL (Mr. Grant Keath), Fort Monroe, VA 23651-5000 - One (1) copy.

7.3 CDR US Army Information Command, ATTN: ATZS-EHE (Mr. William Stein, DEH Energy Coordinator), Fort Huachuca, AZ, 85613-5000 - six (6) copies.

7.4 U.S. Army Corps of Engineers, Mobile District, ATTN: CESAM-EN-CC (Mr. Tony Battaglia), P.O. Box 2288, Mobile, AL 36628-0001 - one (1) copy.

7.5 U.S. Army Corps of Engineers, Sacramento District, ATTN: CESPCK-ED-M (Mr. Hunter), 1325 J Street, Sacramento, CA 95814-2922 - five (5) copies.

8. Government Furnished Documents:

8.1 ETLs: 1110-3-282, Energy Conservation; 1110-3-301, Entrance Doors to Heater/Boiler Rooms; 1110-3-318, Procedures for Programming Energy Monitoring and Control Systems (EMCS) Funded through MCA Program; and, 1110-3-332, Economic Studies.

8.2 Architectural and Engineering Instructions/Design Guide Criteria dated 9 December 1991.

8.3 Energy Conservation Investment Program (ECIP) Guidance dated 10 January 1994 and the latest revision with current energy prices and discount factors for life cycle cost analyses.

8.4 TMs: 5-785, Engineering Weather Data; 5-800-2, General Criteria Preparation of Cost Estimates; 5-800-3, Project Development Brochure; and, 5-815-2, Energy Monitoring and Control Systems (EMCS).

8.5 Information on existing EMCS studies, designs, construction contracts, or operating systems.

8.6 ARs: 415-15, 1 Jan 84, Military Construction, Army (MCA) Program Development, Cost Estimating for Military Programming; 415-20, Construction, Program Development and Design Approval; and, 5-4, Change No. 1, Department of the Army Productivity Improvement Program.

8.7 The latest MCP Index.

8.8 Available as-built drawings, property book records, energy records, existing equipment data, fuel consumption records, etc.

8.9 The latest applicable Engineer Improvement Recommendation System (EIRS) bulletin.

8.10 Example of correctly completed implementation document for a project.

8.11 EEAP, Basewide Energy System Plan, Fort Huachuca, Arizona, dated 1981.

8.12 DEH EMCS Design Drawings, Number 91-039 (22 sheets) and Number 92-016 (12 sheets).

A computer program titled "Life Cycle Costing in Design" (LCCID) is available from the BLAST Support Office in Urbana, Illinois for a nominal fee. This computer program can be used for performing the economic calculations for ECIP and non-ECIP ECOs. The BLAST Support

Office can be contacted at 144 Mechanical Engineering Building, 1206 West Green Street, Urbana, Illinois 61801. The telephone number is (217) 333-3977 or 1-800-UI-BLAST.



NATHANIEL HUNTER  
Project Manager

DISTRIBUTION:

A-E: Keller and Gannon (Mr. Lennig/Mr. Horst)  
DEH: ATZS-EH-E (Mr. William Stein)  
COE: CESAM-EN-CC (Mr. Battaglia)  
COE: CESPDM-PM-M

## ANNEX E

## BUILDING LIST

FOR

SPECIFIC ECO'S EVALUATION, ESOS STUDY, FORT HUACHUCA, AZ

ITEM	BUILDING NO.	CAT. CODE	DESCRIPTION	SF
1.	15544*		INSTRUCTION BLDG.	12,990
2.	20200*		RESIDENTIAL DUPLEX	3,808
3.	22422*		FAC. ENGR. BLDG. (ADMIN)	12,474
4.	30118**		COLD STORAGE WAREHOUSE	17,577
5.	43002**		OFFICERS CLUB	31,430
6.	43083*		VISITORS QUARTERS	83,230
7.	51105**		-----	-----
8.	52054**		GUEST HOUSE	13,064
9.	53301**		COMM. EQUIP. FAC.	40,000
9.	56301**		COMM. EQUIP. FAC	30,000
10.	57428**		COMM. EQUIP. FAC.	18,998
11.	61701*		GYM & INDOOR POOL	52,158
12.	<del>x 61801**</del>		<del>ADMI., COMPUTER,</del>	<del>424,634</del>
			<del>ELECTRONICS BLDG.</del>	
13.	62704**		<del>INSTRUCTION BLDG.</del>	18,733
14.	67601**		MIDDLE SCHOOL	50,000
15.	70525*		NCO CLUB	22,464
16.	80305**		BARRACKS	50,680
17.	80505**		TTA INSTRUCTION BLDG.	72,000
18.	<del>x 90201**</del>		<del>LAUNDRY</del>	<del>35,993</del>
19.	90312*		WAREHOUSE	36,920
20.	90506**		SALVAGE STORAGE	4,800
21.	90508**		STORAGE WAREHOUSE	8,640
22.	<del>x 907XX**</del>		<del>SEWAGE TREATMENT PLANT</del>	
23.	91114*		AIRFIELD MAINT. HANGER	35,973

\* SPECIFIC ECO'S AS SPECIFIED IN PARAS 3 & 4 OF ENCLOSURE 1.

\*\* SPECIFIC ECO'S AS SPECIFIED IN PARAS 2, 4, 5, 6, AND 7 OF ENCLOSURE 1.

ANNEX D

EXECUTIVE SUMMARY GUIDELINE

1. Introduction.
  2. Boiler Data. (Number, sizes, efficiency, etc.)
  3. Present Energy Consumption.
    - o Total Annual Energy Used.
    - o Source Energy Consumption.
      - Electricity - KWH, Dollars, BTU
      - Fuel Oil - GALS, Dollars, BTU
      - Natural Gas - THERMS, Dollars, BTU
      - Propane - GALS, Dollars, BTU
      - Other - QTY, Dollars, BTU
    - o Energy Consumption by Systems.
  4. Historical Energy Consumption.
  5. Energy Conservation Analysis.
    - o ECOs Investigated.
    - o ECOs Recommended.
    - o ECOs Rejected. (Provide economics or reasons)
    - o ECIP Projects Developed. (Provide list)\*
    - o Non-ECIP Projects Developed. (Provide list)\*
    - o Operational or Policy Change Recommendations.
    - o Recommended Boiler Air/Fuel Mix Setting (Based UPON test performed on stack gases emission).
- \* Include the following data from the life cycle cost analysis summary sheet: the cost (construction plus SIOH), the annual energy savings (type and amount), the annual dollar savings, the SIR, the simple payback period and the analysis date. For all programmed projects also include the year in which it is programmed and the programmed year cost.
6. Energy and Cost Savings.
    - o Total Potential Energy and Cost Savings.

- o Percentage of Energy Conserved.
- o Energy Use and Cost Before and After the Energy Conservation Opportunities are Implemented.

7. Energy Plan.

- o Project Breakouts with Total Cost and SIR.
- o Schedule of Energy Conservation Implementation.

ANNEX C

REQUIRED DD FORM 1391 DATA

To facilitate ECIP project approval, the following supplemental data shall be provided:

- a. In title block clearly identify projects as "ECIP."
- b. Complete description of each item of work to be accomplished including quantity, square footage, etc.
- c. Claims for boiler and chiller plants efficiency improvements must identify data to support present properly adjusted boiler operation and future expected efficiency. If full replacement of boilers is indicated, explain rejection of alternatives such as replace burners, nonfunctioning controls, etc. Assessment of the complete existing installation is required to make accurate determinations of required retrofit actions.
- d. List references, and assumptions, and provide calculations to support dollar and energy savings, and indicate any added costs.
- e. An ECIP life cycle cost analysis summary sheet as shown in the ECIP Guidance shall be provided for the complete project and for each discrete part included in the project. The SIR is applicable to all segments of the project. Supporting documentation consisting of basic engineering and economic calculations showing how savings were determined shall be included.
- f. The DD Form 1391 face sheet shall include, for the complete project, the annual dollar and MBTU savings, SIR, simple payback period and a statement attesting that all buildings and retrofit actions will be in active use throughout the amortization period.
- g. The calendar year in which the cost was calculated shall be clearly shown on the DD Form 1391.
- h. The five digit category number for all ECIP projects except for Family Housing is 80000. The category code number for Family Housing projects is 71100.
- i. Lighting retrofit projects must identify number and type of fixtures, and wattage of each fixture being deleted and installed. New lighting shall be only of the level to meet current criteria. Lamp changes in existing fixtures is not considered an ECIP type project.

## ANNEX A

### GENERAL ENERGY CONSERVATION OPPORTUNITIES

- o Controls to assure proper combustion air-fuel ratio.
- o Feedwater Treatment.
- o Installation of new burner equipment.
- o Economizer/air preheaters.
- o Reduce excess air.
- o Loading characteristics and scheduling versus equipment capacity (equipment optimization).
- o Variable speed circulation pumps or alternate pumps based on seasonal loading.
- o Steam pressure or hot water temperature reduction based on seasonal loading and/or existing and projected requirements.
- o reduction in makeup water quantities.
- o Evaluation of electric versus absorption chillers for replacement.
- o Control system to operate chillers at their most efficient operating condition.
- o Blowdown control:
- o Common manifolding of chillers
- o Prevent air leakage.
- o Condenser/cooling tower water treatment.
- o Variable or two-speed cooling tower fan.
- o Free cooling cycle in lieu of chiller operation.
- o Storage of chilled water.
- o High efficient motors.
- o Steam driving auxiliaries versus electric drives.
- o Variable speed induced draft fans and forced draft blowers.
- o Instruments and controls facilitate efficient operations.

- o Variable volume pumping.
- o Use of smaller boilers where load has been reduced.
- o Correct sizing of traps.
- o Replace inefficient boilers with more efficient boilers.
- o Replace inefficient chillers with more efficient chillers.
- o Replace existing fluorescent lighting ballasts and lamps with more efficient lighting ballasts and lamps.
- o Occupancy sensors to control lighting.
- o Photocells to control lighting.
- o Separate switches to control lighting arrangements.

ANNEX F\*  
BUILDING LIST

FOR  
ENERGY AUDIT, SURVEY, HUACHUCA, AZ

ITEM	BUILDING NO.	CAT. CODE	DESCRIPTION	SF
1.	15544		INSTRUCTION BLDG.	12,990
2.	41410		-----	-----
3.	43002		OFFICERS CLUB	31,430
4.	43083		VISITORS QUARTERS	83,230
5.	61701		GYM & INDOOR POOL	52,158
6.	70525		NCO CLUB	22,464
7.	80305		BARRACKS	50,680

\*ENERGY AUDIT/SURVEY/ANALYSIS TO BE CONDUCTED UNDER THE BASIC STUDY.

ANNEX G\*  
BUILDING LIST

FOR  
ENERGY AUDIT, SURVEY, HUACHUCA, AZ

ITEM	BUILDING NO.	CAT. CODE	DESCRIPTION	SF
2.	20200		RESIDENTIAL DUPLEX	3,808
3.	22422		FAC. ENGR. BLDG. (ADMIN)	12,474
4.	30118		COLD STORAGE WAREHOUSE	17,577
8.	44411		-----	-----
7.	51005		-----	-----
8.	51105		-----	-----
8.	51420		-----	-----
7.	52054		GUEST HOUSE	13,064
9.	53301		COMM. EQUIP. FAC.	40,000
10.	56301		COMM. EQUIP. FAC	30,000
11.	57428		COMM. EQUIP. FAC.	18,998
12.	62704		INSTRUCTION BLDG.	18,733
13.	67601		MIDDLE SCHOOL	50,000
14.	70525		NCO CLUB	22,464
15.	80305		BARRACKS	50,680
16.	80505		TTA INSTRUCTION BLDG.	72,000
17.	90312		WAREHOUSE	36,920
18.	90506		SALVAGE STORAGE	4,800
19.	90508		STORAGE WAREHOUSE	8,640
20.	907XX		SEWAGE TREATMENT PLANT	-----
21.	91114		AIRFIELD MAINT. HANGER	35,973

\*ENERGY AUDIT/SURVEY TO BE CONDUCTED UNDER OPTION 1.

## CONFERENCE MINUTES (DRAFT)

SUBJECT: Energy Engineering Analysis Program (EEAP), FY93, Energy Savings Opportunity Survey, Fort Huachuca, Az.

1. A scope clarification and review conference was held at Fort , Huachuca, AZ on 26 May 1993. The persons in attendance are listed below.

<u>NAME</u>	<u>REPRESENTING</u>	<u>PHONE NUMBER</u>
Mr. Richard Lennig	Keller and Gannon	(415) 621-1199
Mr. William Stein	ATZS-EH-E, FT. Huachuca DEH	(602) 533-1861
Mr. Nathaniel Hunter	CESPK-ED-M/ISS, COE	(916) 557-7413

2. It was noted that the General Scope of Work (GSOW) out lines the study procedures and documentation requirements and the Detailed Scope of Work (DSOW) will define specific buildings, systems and tasks to be investigated. A summary of the conference is indicated below:

a. It was noted that should the DSOW and the GSOW conflict the DSOW will govern.

b. The conference discussion focused on the DSOW dated 1 April 93 prepared by Mr. Stein of ATZS-EH-E - see enclosure 1. The ATZS-EH-E DSOW identified a number of cogeneration and electric generating alternatives to be evaluated as part of subject study. The undersigned explained that the ESOS was intended for evaluating ECOs of the types listed in annex A of the GSOW and that the approval of Mr. Battaglia, CESAM-EN-CC, Mobile District is required to for the study of cogeneration and electric generation facilities. TM action.

c. The undersigned also noted that the study of cogeneration and electric generation would be negotiated as options. The cogeneration and electric generation options to be included are indicated in paragraph 4 of enclosure 2

d. Mr. Stein provided some general information (historical, current, and projected) about Fort Huachuca operations and facilities - see paragraph 2, Keller & Gannon (A-E) Minutes of Meeting dated 1 June 1993, enclosure 2.

e. Paragraph 3 of enclosure 2 lists several facilities that will not be included in the ESOS study. Existing temporary buildings and building on the historical register such as the old barracks listed in enclosure 2 will be excluded.

f. It was explained that Fort Huachuca does not have an existing operating EMCS in place. A final design of an EMCS for 13 buildings is underway. Enclosure 1 requests thet subject study include an economic analysis for the expanding EMCS to 100 buildings. This effort would also be an option. Mr. Stein will develop the list of buildings for EMCS evaluation.

g. Mr. Stein also asked that the A-E monitor the harmonic distortion at the main power distribution panel in five buildings - see paragraph 6 of enclosure 2. This task will be added to the basis

ECOs list of annex A.

h. Mr. Stein will provide the undersign with a list of the buildings and specific ECOs to be included in the study.

  
NATHANIEL HUNTER  
Technical Manager

cc:  
A-E: Keller and Gannon (Mr. Lennig)  
DEH: ATZS-EH-E, Fort Huachuca (Mr. Stein)  
TCX: CESAM EN-CC (Mr. Tony Battaglia)  
Mil Proj Br, A-E Nego Sec  
Mil Proj Br, ISS (Hunter)

3 June 1993

Detailed Scope of Work for  
Fort Huachuca ESOS

Per our meeting and discussion on 26 May 1993, the following detailed Scope of Work is submitted for the ESOS for Fort Huachuca.

The following is in priority order.

1. The cogeneration study as outlined in the 1 April 1993 detailed scope of work with the addition of looking at electrical generation only.
2. Analyze Building 56301 for high efficiency lighting, motors, natural gas cooling, improved HVAC controls, and application of a low emissivity roof coating.
3. Analyze thermal envelop upgrades on the following buildings: 15544, 20200, 22422, 41410, 43083, 44411, 51005, 51420, 61701, 70525, 90312, and 91114.
4. Analyze efficient lighting and motors upgrades on the following buildings: 155XX, 20200, 22422, 43002, 43083, 52054, 53301, 57428, 61701, 62704, 70525, 80305, 80505, 90312, 90506, 90508, 907XX, and 91114.
5. Analyze efficient motor upgrades on the following buildings: 30118, 61801, and 67601.
6. Analyze buildings 51105 and ~~61801~~ for application of a low emissivity roof coating.
7. Study the equipment, lighting and motors in the post laundry, building 90201.
8. Add buildings to the EMCS system. The drawings and specifications are available from Rhaj Sandu at the Sacramento Corps of Engineers. Look at adding up to 50 more buildings.

*William J. Stein*

William J. Stein  
Energy Coordinator  
(602) 533-1861

ENCL 1

**KELLER & GANNON**  
Engineers & Architects  
Quality Services Since 1941

Post-It™ brand fax transmittal memo 7671		# of pages ▶ 4
To: AMI NAT CENTER	From: RICH LENNIG	
Co. SACRAMENTO DISTRICT	Co. KELLER & GANNON	
Dept. CESPKE-ED-M/ISS	Phone #	
Fax # 916-557-7805	Fax #	

1 June 1993

MINUTES OF MEETING

**AT:** Directorate of Engineering and Housing, Building 22422  
Fort Huachuca, Arizona

**ON:** 26 May 1993

**SUBJECT:** Energy Savings Opportunity Study (ESOS)  
Fort Huachuca, Arizona

**ATTACHMENTS:** (1) Base-Wide Energy Study, Fort Huachuca, Prepared by  
Sullivan & Masson in 1980 (4 Volumes)  
(2) Base-Wide Energy Study Increment F, Fort Huachuca,  
Prepared by The Ellers Masson Group in 1983  
(3) DA Energy Awareness Program, Building Energy Monitors  
Session  
(4) Energy Policy Presentation, Dated 4 May 1993  
(5) General Site Maps, Fort Huachuca, 1"=400'  
(Sheet Nos. 7, 8, 9, 10 of 42)

**THOSE PRESENT:**

<u>Name</u>	<u>Affiliation</u>	<u>Telephone No.</u>
Bill Stein	Energy Coordinator, DEH, Fort Huachuca	602-533-1861
Nathaniel Hunter	CESPK-ED-M/ISS, COE Sacramento	916-557-7413
Richard Lennig	Keller & Gannon	415-621-1199

1. The purpose of the meeting was to discuss the detailed scope of work for an Energy Savings Opportunity Study of Fort Huachuca, Arizona.
2. General information concerning Fort Huachuca was provided as follows:
  - a. Missions at the post include:

\\TMP\05-26MN1.RCL  
930601-1

1453 Mission Street, San Francisco, California 94103  
Phone: (415) 621-1199 FAX: (415) 864-3681  
Mail: P.O. Box 422430, San Francisco, CA 94142-2430

- Electronic Proving Ground
  - Information Systems Command
  - Joint Test Facility
  - U.S. Army Intelligence School
- b. The post currently has 8 million SF of facilities, due to increase to approximately 9 million SF upon completion of current and programmed construction projects.
- c. The post contains approximately 800 facilities, plus 1,954 family housing units.
- d. Total installed refrigeration capacity is  $\pm$  5,000 tons.
- e. Electricity is supplied by Tucson Electric Power Co. at an overall cost of \$30.00/million BTU. At 20 MW, Fort Huachuca represents 5 percent of Tucson Electric Power's total load. The cost of electricity in FY92 was approximately \$6.5 million.
- f. Two natural gas transmission mains serve the post, with the point of connection at pressure-reducing stations near the east and west boundaries. Primary supply is from the west connection with peak periods augmented from east side connection. The annual natural gas bill is approximately \$3 million.
- g. Rate increases for both electricity and natural gas of 10 percent are expected in 1994.
3. A considerable amount of energy-savings project development already has been accomplished at Fort Huachuca. The following facilities will not be included in this ESOS scope:
- a. Hospital: A \$300,000 ECIP project already has been funded.
  - b. Greely Hall (400,000-SF): This facility is in a continuous state of renovation.. Mechanical equipment rooms should be included in the survey.
  - c. Old barracks complexes.
  - d. Family housing, except for consideration of overhangs. Many of the housing units have up to 40-percent glass in exterior walls, including southern and western exposures. There are 29 types of family housing.

4. The cogeneration options listed in the 1 April 1993 Detailed Scope of Work from B. Stein were clarified as follows:
  - a. There are two existing heating/cooling plants that serve a complex of buildings, plus one plant yet to be constructed. One of the existing plants contains chilled water storage and a Johnson Controls EMCS.
  - b. The option described under Item 1.d., Public Utility Regulatory Act of 1978 (PURPA) qualifying facility, will be included under other cogeneration options.
  - c. Option 1.h. will consider an electrical generating facility serving Fort Huachuca that reduces peak demand changes by Tucson Electric Power Co.
  - d. Assume that project documentation for cogeneration and generation options will consist of two DD Form 1391 packages.
  - e. The Sulfur Springs Valley Cooperative provides electrical power to the town of Sierra Vista, with a total demand of 20–30 MW. The cooperative purchases 50 percent of the power that it distributes. Fort Huachuca is within the city limits of Sierra Vista.
  - f. According to B. Stein, meeting air quality standards should not be a problem. The increase in gas burned for on-site generation may be offset by the reduction in gas usage by local heating plants.
5. The existing Base-wide EMCS, which includes 13 buildings, is at the completed design stage only. The largest 100 building loads are to be determined by the A/E. It was noted that in existing JC80 EMCS in Greely Hall is not functional.
6. The A/E will monitor harmonic distortion at the main distribution panel of 5 buildings considered to have the largest percentage of installed nonlinear loads. This sample survey will be used to determine whether harmonic filters are required at sensitive equipment due to retrofits such as electronic ballasts and variable frequency drives that generate additional harmonic distortion of the current and voltage waveforms.
7. The following documents were provided (or will be provided) to the A/E:
  - a. Base-Wide Energy Study, Fort Huachuca, 1980–1983 (Attachments [1] and [2])

- b. DA Energy Awareness Program (Attachment [3])
  - c. Energy Policy Presentation, 4 May 1993 (Attachment [4])
  - d. General Site Maps, 4 Sheets @ 1"=400' (Attachment [5])
  - e. Gulf States Cogeneration Program (to be provided)
  - f. Base-Wide EMCS Design Package (to be provided)
  - g. Base-Wide Energy Records for the Past 5 Years (to be provided)
8. To further clarify the ESOS Scope of Work, B. Stein will provide to N. Hunter of CESPCK a list of buildings to be investigated by the A/E. This list will include the following data and annotations:
- a. Building square footage
  - b. Facilities with large loads to be evaluated for absorption cooling
  - c. Facilities where escorts are required
9. Following the meeting, a windshield tour of Fort Huachuca was made by N. Hunter, B. Stein, and R. Lennig.

  
Richard C. Lennig

RCL:kt  
16-403-11

Copy without attachments to:

Mr. Nathaniel Hunter, CESPCK ED-M/ISS  
Corps of Engineers, Sacramento District

12 January 1995

MINUTES OF MEETING

AT: Directorate of Engineering and Housing, Fort Huachuca, Arizona

ON: 10 January 1995

SUBJECT: Contract No. DACA05-C-92-0155  
EEAP, FY93, Energy Savings Opportunity Survey  
Fort Huachuca, Arizona, Interim Submittal Presentation

- ATTACHMENTS:
- (1) Interim Submittal Review Comments: William Stein, ATZS-EHE, Fort Huachuca, Dated 2 December 1994
  - (2) Interim Submittal Review Comments: Memorandum for Bobby Harman, CEHND-PM-CR from Plyler McManus, P.E., Received 22 November 1994
  - (3) Interim Submittal Review Comments: Robert S. Woodruff, EN-DM, Mobile District Corps of Engineers, Dated 30 September 1994
  - (4) Keller & Gannon Responses to Review Comments

THOSE PRESENT:

<u>Name</u>	<u>Affiliation</u>	<u>Telephone No.</u>
Alex Azares	CESPK-ED-M (Army/ISS)	916-557-5126
William Stein	Fort Huachuca Energy Mgt Office	602-533-1861
Tony Battaglia	C.O.E., Mobile, Alabama	205-690-2618/2424
Greg Noble	Southwest Gas Corporation	602-794-6429
Richard C. Lennig	Keller & Gannon	415-621-1199
Blair I. Horst	Keller & Gannon	415-621-1199

1. The purpose of the meeting was to present findings of the subject study and to discuss and resolve review comments on the Interim Submittal.

2. Findings of the subject energy study were presented to the attendees by R. Lennig and B. Horst.
3. Interim submittal review comments and Keller & Gannon (K&G) responses were discussed — refer to Attachments (1) through (4). All K&G responses were accepted with the following clarifications:
  - a. William Stein Comment Nos. 3 and 4: The report will be clarified and calculations will be revised accordingly with a corrected natural gas, electrical demand and usage charges.
  - b. William Stein Comment No. 7 (refer to responses to Bobby Harman Comment No. 4): Cogeneration alternatives utilizing reciprocating engine-generator sets, prepared in draft for the Interim Submittal review meeting, will be incorporated into the Prefinal Submittal documents.
  - c. William Stein Comment No. 9: Energy saving project cost estimates will be modified for preparation of funding request documents using DA Form 4283, Facility Engineering Work Request, by adjusting to remove subcontractor markups on line item costs. The cost estimate modifications requested will result in cost estimates more in line with Supply Contracts recently negotiated by Mr. Stein for several energy saving projects.
  - d. William Stein Comment No. 10: Product information for the reflective coating will be added to the appropriate appendix.
  - e. Bobby Harman Comment No. 4: Cogeneration alternatives utilizing reciprocating engine-generator sets, prepared in draft for the Interim Submittal review meeting will be incorporated into the Prefinal Submittal documents.
  - f. Robert S. Woodruff Comment No. 2: Table 4-5 will be modified to clarify the information; "dry-bulb economizer" will be added to the project description.
  - g. Robert S. Woodruff Comment No. 4: Product information for the reflective coating will be added to the appropriate appendix.
4. During the meeting, Mr. Battaglia noted an error in the formulas shown on page 5-2; the error will be corrected.

5. Mr. Noble of Southwest Gas Corporation stated he has not heard back yet from the El Paso Natural Gas Company (operators of the interstate gas transmission pipeline) regarding availability of natural gas supplies for power generation Alternatives 2 and 3. (Power Generation Alternatives 2 and 3 are developed for providing 100% of the power requirements for Fort Huachuca and/or the city of Sierra Vista.) There is a possibility that a new compressor station would be required. Mr. Horst added that the approximate \$40 million cost for such a station would effectively "kill" Alternatives 2 and 3. A response from El Paso Natural Gas Company might be expected within the next few months, probably too late to be reflected in the Prefinal Submittal.
6. It was agreed that funding documents to be prepared for the Prefinal Submittal shall be prepared on DA Forms 4283, Facility Engineering Work Requests. It is not necessary to prepare funding request documentation on DD Forms 1391.



Blair I. Horst

BIH:kt  
16-403-13

Copy without attachments to:  
Mr. Alex Azares, CESP-K-ED-M/ISS  
Corps of Engineers, Sacramento District



**ENGINEERING REVIEW COMMENT CONT.** **PR NO. F50.5**

Sheet No. Para No.	Item No.	COMMENTS	ACTION
pg 6-1 →	7	We need to discuss this at the 10 Jan 95 meeting. This part of the study was discussed at a meeting w/ The Ohio Electric Power Company. Needs some re-fixing	
pg C-5	B	We have found from a recent contract that the cost of high efficiency motors is significantly less than these estimates. This changes the economics greatly!	
pg H-10	9	Material and labor costs on current contracts are only \$45 - not \$69 for 2 TB lamps and 1 electronic ballast retrofit. This changes the economics significantly. Some of other parts of retrofit \$! Demand savings in all analysis should be $10.17 \times 12 = 122.34$ No more U tubes please - use F17TB, new bracket; white reflectors for retrofit!	
K-143	10	How did you model the LOWe retrofit?	



### U.S. Army Corps of Engineers Huntsville Division

Facsimile Transmittal

**TO:** Name: MR. AZARES  
 Office: CESPK-ED-M  
 Tel: 916-557-5126  
 FAX: 916-557-7850

**FROM:** Name: BOBBY HARMAN  
 Office: CEHND-PM-CR  
 Tel: 205-955-4887  
 FAX: 205-955-4664

Number of Pages: 2 (Including Header)

**SUBJECT:** FORT HUACHUCA COGENERATION STUDY

Message:

MR. AZARES,  
MR. TONY BATTAGLIA AT MOBILE DISTRICT  
REQUESTED WE TAKE A LOOK AT THE SUBJECT  
STUDY WITH REGARD TO FEASIBILITY AS AN  
ENERGY SAVINGS PERFORMANCE CONTRACT (ESPE).

OUR TECHNICAL STAFF HAS REVIEWED THE  
STUDY AND COMMENTS ARE ATTACHED.

PLEASE GIVE ME A CALL IF YOU DESIRE TO  
DISCUSS THE PROJECT IN FURTHER DETAIL.

*Bobby Harman*  
**PROJECT MANAGER**

DATE REC'D: 11/22/94

TIME REC'D: 8:08 am

PROJECT No.: \_\_\_\_\_  
ORIGINAL: ACC FILE

COPY: TMR

MEMORANDUM FOR: Bobby Harman

SUBJECT: Cogeneration, Fort Huachuca

NARRATIVE: 1. I was asked by Bobby Harman to review an energy report provided to him which evaluates the economic feasibility of various cogeneration plant configurations which would supply electrical power and thermal energy to Fort Huachuca and in some cases the city of Sierra Vista. I have been asked to evaluate the proposed plant configurations to determine the feasibility of procuring the plants via a performance contract.

2. The report presents various alternative plant configurations with savings to investment ratios ranging from 0.98 to 1.74. Based on these figures, a performance contractor would not be able to receive a return on investment sufficient to offset the risk involved with the project. A savings to investment ratio of 3 or greater is typically required to interest investors.

3. A Third Party Contract is probably the most viable alternative for this type of work, particularly if the city of Sierra Vista is to be involved. Third Party Contracts for energy services have not been implemented since the mid 1980's due to changes in the tax laws and the requirement that MCA alternative be a less attractive alternative so I don't recommend that this approach be pursued unless Sierra Vista is involved in the project.

4. The proposed project is very aggressive and capital intensive. A quick check of the system first costs show an investment of between \$1600 per kw to \$2600 per kw which is high. The report alludes to a peak electrical demand of approximately 20 MW with a base demand of 9 MW. Based on this very limited data it appears that up to half of the installations demand may be eliminated with generation/cogeneration. I would recommend that a less aggressive approach be evaluated where by reciprocating engines are used to shave an optimum amount of electrical demand with heat recovery added as required to match the available thermal load. With only \$10 per KW demand to work with, the optimum plant would probably only be able to shave 5-7 MW, but this would depend heavily on the installations electrical load profile.

5. If you have any questions, call Plyler McManus at 205-955-5200



Plyler McManus, P.E.

<b>MOBILE DIST. OFFICE PROJECT REVIEW COMMENTS</b>		<b>DATE:</b> 30 SEP 94	<b>PAGE</b> 1 of 1
<b>TO:</b> CoE Sacramento Dist. Nathaniel Hunter		<b>FROM:</b> (Section): EN-DM (Reviewer): Robert S. Woodruff	
<b>PROJECT:</b> Energy Engineering Analysis Program <b>LOCATION:</b> Fort Huachuca, Arizona		<b>Year:</b> FY-94	<b>Line Item No.:</b>
<b>Type of Action:</b> 50+ Study Review			

Item No.	Drawing No. Or Par. No.	Comments	Review Action
1.	Vol. 1 Page 4-7	The minimum savings to investment ratio (SIR) for projects to be considered for construction is now 1.25. This was changed in the 10 January 1994 revised guidelines.	
2.	Vol. 1 Page 4-11	The savings produced by the Dry Bulb economizer controls should be presented in the study.	
3.	Vol. 1 Page 5-2	The study on Harmonic Distortion should address what effect the ECIP recommendations would have on this problem. Would the electronic lighting fixture ballasts make this situation worse ?	
4.	Vol. 2 Appx E Page E-6	If the LO-E roof coating increases the heating load on some buildings why doesn't it increase the heating load on all buildings on which it is used? Please supply more information on this coating.	

**EEAP Energy Savings Opportunity Survey, Fort Huachuca, Az**  
**Responses to Review Comments on Interim Submittal**

Reviewer: William Stein, ATZS-EHE 2 December 1994

Page/ Reference	Comment Number	Comment	K&G Response
3-1	1	Ft. Huachuca climatological data shows 30-year (1961-1990) average for CDD to be 1566 and the average HDD to be 2510.	CDD is 30-year mean from same source, HDD is from TM 5-785; both approaches are valid. The 1,777 CDD value is an error and will be corrected. The text statements will be clarified, calcs would not be significantly changed, and will, thus, not be modified.
3-2	2	Para 3.3.1 the 3 chillers are 400 Tons each, not 350 Tons. The chiller water storage is in one tank of 480,000 gallons. As of Dec '94, there is a contract to simplify the controls of the North Plant.	Chiller sizes will be corrected and thermal storage configuration will be clarified. The controls simplification construction contract will be mentioned in the text.
4-1	3	Para 4.1.2.1 the demand charge is \$10.17/kW.	The electric demand cost, adjusted for 97% power factor and tax is \$10.63 / kW-Month. Calculations will be revised appropriately.
	4	not used	
4-2	5	Para 4.1.2.2 the current total cost of natural gas is \$0.4518/therm.	Costs reported and used are from the SWG rate sheet, adjusted for state tax. No change will be made for these new rates.
4-4	6	Para 4.4.2 Model Energy Code requires R-19 not R-11 in walls.	Noted; text will be modified to state that wall insulation retrofits included as much added insulation as existing wall construction could economically accomodate.
6-1	7	We need to discuss this at the 1/10/95 mtg. This part of the study was discussed at the meeting with Tuscon Electric Power Company. Needs some refining.	Noted. K&G is anxious to discuss refinements.
6-5	8	We have found from a recent contract that the cost of high efficiency motors is significantly less than these estimates. This changes the economics greatly!	Noted. Prices shown are based on averages from the "DOE Energy Efficient Motor Handbook".
H-10	9	Material and labor costs on current contracts are only \$45, not \$69 for 2T8 lamps and one electronic ballast retrofit. This changes the economics significantly. Same for the other parts of Section H! Demand savings in all analyses should be \$10.17 x 12 = \$122.34 per kW-Year. No more U-Tubes please, use F17T8, with(?) bracket and white reflector for retrofit!	Labor rates used for lighting estimates are from Means '94 estimating guide, adjusted to Tucson, the nearest location for which Means has adjustment factors. Demand costs include the effect of the power factor correction credit. U-Tube retrofit is already not economic. Requiring added fixture modifications will increase the cost without improving economic performance.
K-143	10	How did you model the Low-E coating?	The "Absorptivity" of the roof structure is modified for Carrier HAP-30 simulations.

## Responses to Review Comments on Interim Submittal, continued

**Reviewer:** Bobby Harman CEHND-PM-CR, Plyier McManus, P.E. **Received:** 22 November 1994  
**Note:** Mr. Tony Battaglia, Mobile District requested review per an Energy Savings Performance Contract (ESPC).

Comment Number	Comment	K&G Response
1	Narrative: He has been asked to review various plant configurations to determine the feasibility of procuring plants via a performance contract.	Noted
2	SIRs range from 0.98 to 1.74; <u>performance contractors</u> want better economics, with SIRs of about 3.0 or higher.	Noted.
3	<u>Third Party Contract the most viable alternative,</u> particularly if Sierra Vista is to be involved. Third Party Contracts not implemented since early 1980s because of tax laws and requirement that MCA be less attractive. He does not recommend this approach	Noted.
4	Proposed project very aggressive & costly: \$1,600/kW to \$2,600/kW. Recommends a less aggressive approach using reciprocating engines, sized to match the thermal load via heat recovery. Optimum plant size would probably be 5 MW to 7 MW, depending on the load profile.	Alternative 1B is prepared for a 4.7 MW plant using a gas turbine and absorption chiller. Plant cost is about \$2,900 per kW. K&G will reevaluate Option 1B with reciprocating engine-generator sets and waste heat recovery rather than turbine-generators.
5	For any questions, call (205) 955-5200	Thank you.

**Reviewer:** Robert S. Woodruff, CESPCK-EN-DM for Tony Battaglia **30 September 1994**

Page/ Reference	Comment Number	Comment	K&G Response
Vol 1, 4-7	1	Minimum SIR for construction is now 1.25 per 10 January 1994 revised guidelines.	Projects are evaluated on a room-by-room or motor-by-motor basis with results totaled for each building. The resulting <u>total</u> SIR is tested against the 1.25 minimum. In lighting projects, for example, it is not reasonable to retrofit only those rooms that have the best SIRs; operations and maintenance is much more cost effective if only one type of fluorescent lamp is stocked.
Vol 1, 4-11	2	Savings produced by dry bulb economizer controls should be presented in the study.	Both the HVAC control retrofit evaluations summarized on Table 4-5 do include dry-bulb economizer control. This will be clarified.
Vol 1, 5-2	3	The study on Harmonic Distortion should address what effect the ECIP recommendations would have on this problem. Would electronic lighting fixture ballasts make the situation worse?	Requiring electronic ballasts to have a minimum current THD of 10% would not increase, and would possibly reduce, overall distortion levels. Refer to page 5-3.
Vol 2, E-6	4	If the LO-E roof coating increases the heating load on some buildings why doesn't it increase the heating load on all buildings on which it is used? Please supply more information on the coating.	It does increase the heating load for those surfaces upon which it is applied. Product information sheets will provided, to be added to Appendix E.

**APPENDIX B**

**Utility Rate and Rebate Schedules**



**APPENDIX B  
Table of Contents**

Tucson Electric Power (TEP) Company Rate Schedule . . . . . B-1

TEP Optional Backup Service Rate Schedule . . . . . B-2

TEP Commercial and Industrial Lighting Efficiency Program Rebate Schedule . . . . . B-4

TEP Commercial and Industrial Motor Efficiency Program Rebate Schedule . . . . . B-6

TEP Commercial and Industrial High Efficiency Cooling Systems Rebate Schedule . . . . . B-7

Southwest Gas Company Rate Schedules . . . . . B-8



TUCSON ELECTRIC POWER COMPANY  
Tucson, Arizona  
Filed by: Norman E. Johnson  
Title: Vice President, Sys. Plan. & Pricing  
District: Entire Electric Service Area

A.C.C. No. 565-K  
Cancelling A.C.C. No. 565-J  
Rate Schedule No. 14  
Sheet No. 1  
Tariff No. 7  
Filing: JANUARY 11, 1994  
Effective: Consumption on and  
after January 11, 1994

LARGE LIGHT AND POWER RATE NO. 14

AVAILABILITY

Rate No. 14 shall be available for any customer within the service territory of the Company if the Company has facilities of adequate capacity and a written contract, covering such matters as the Company and Customer shall determine, is executed for such service.

CHARACTER OF SERVICE

Service shall be three phase, 60 Hertz, and shall be supplied directly from any 46,000 volt, or higher voltage, system through distribution facilities used exclusively to serve Rate 14 customers at a delivery voltage of not less than 2400/4160 volts and delivered at a single point of delivery unless otherwise specified in the contract.

RATE

A monthly net bill at the following rate plus any adjustments incorporated in this rate schedule:

	<u>BILLING MONTHS</u>	
	<u>Summer</u> <u>May-Oct.</u>	<u>Winter</u> <u>Nov.-Apr.</u>
DEMAND CHARGE: Per kw of Billing Demand per month	\$10.17	\$10.17
ENERGY CHARGE: All kwh per month @	4.6935¢	4.4588¢

BILLING DEMAND

The billing demand shall be specified in the contract, but shall not be less than 3,000 kw.

POWER FACTOR ADJUSTMENT

The above rate is subject to a discount or a charge of 1.3¢ per kw of billing demand for each 1% the average monthly power factor is above or below 90% lagging to a maximum discount of 13.0¢ per kw of billing demand per month.

TAX CLAUSE

To the charges computed under the above rate, including any adjustments, shall be added the applicable proportionate part of any taxes or governmental impositions which are or may in the future be assessed on the basis of gross revenues of the Company and/or the price or revenue from the electric energy or service sold and/or the volume of energy generated or purchased for sale and/or sold hereunder.

TUCSON ELECTRIC POWER COMPANY  
 Tucson, Arizona  
 Filed by: R. W. Rosenwald  
 Title: Mgr., Rates & Economic Services  
 District: Entire Electric Service Area

A.C.C. No. 681  
 Cancelling A.C.C. No. -  
 Rate Schedule No. -  
 Sheet No. 1  
 Tariff No. 7  
 Filing: February 13, 1989  
 Effective: March 16, 1989

OPTIONAL BACKUP SERVICE FOR  
 COGENERATION AND SMALL POWER PRODUCTION QUALIFYING FACILITIES OVER 100 KW

AVAILABILITY

Available throughout Company's entire electric service area where the facilities of the Company are of adequate capacity and are adjacent to the premises.

APPLICABILITY

To any QF when all energy or capacity is supplied by Company at one point of delivery and through one metered service to replace energy ordinarily generated by a facility's own generation equipment during an unscheduled outage of the facility.

CHARACTER OF SERVICE

Single or three phase, 60 Hertz, and at one standard nominal voltage as mutually agreed and subject to availability at point of delivery. Primary metering may be used by mutual agreement.

- \* Service Charge: \$18.00 per month.
- Reservation Charge: All contracted kw per month @ \$ C per kw, where C is derived as follows:

$$\left[ \$15.56 \right] \times \left[ \frac{A}{B} \right] = C$$

A is the number of hours the facility's generation is inoperative in a contract year due to unscheduled maintenance. B is the number of hours in a contract year less the number of hours the facility's generation is inoperative in a contract year due to scheduled maintenance.

For billing purposes, during the first contract year the assumed value of A/B shall be 18%, with a true-up based on actual data at the end of the first contract year. For the second and subsequent contract years, the value used for billing purposes shall be based on the actual value of A/B during the previous contract year.

\* Not applicable if billed under the Optional Maintenance (MF) Service schedule.

Energy Charge: All kwh per month @ 2.19¢ per kwh.

TUCSON ELECTRIC POWER COMPANY  
 Tucson, Arizona  
 Filed by: R. W. Rosenwald  
 Title: Mer., Rates & Economic Services  
 District: Entire Electric Service Area

A.C.C. No. 662  
 Cancelling A.C.C. No. -  
 Rate Schedule No. -  
 Sheet No. 2  
 Tariff No. 7  
 Filing: FEBRUARY 13, 1989  
 Effective: MARCH 16, 1989

OPTIONAL BACKUP SERVICE FOR  
 COGENERATION AND SMALL POWER PRODUCTION QUALIFYING FACILITIES OVER 100 KW  
 (Continued)

PURCHASED POWER AND FUEL COST ADJUSTMENT

Charges for all kwh sold under this rate schedule are subject to the Company's Standard Purchased Power and Fuel Cost Adjustment for Electric Rate Schedules.

TAX CLAUSE

To the charges computed under the above rate, including any adjustments, shall be added the applicable proportionate part of any taxes or governmental impositions which are or may in the future be assessed on the basis of gross revenues of the Company and/or the price or revenue from the electric energy or service sold and/or the volume of energy generated or purchased for sale and/or sold hereunder.

TERMS AND CONDITIONS

- (1) The QF shall reimburse Company upon receipt of statement from Company for all interconnection costs.
- (2) The QF shall operate its electric generating equipment in accordance with Company rules, regulations and service requirements.
- (3) The Company may require a written contract and a minimum term of contract.
- (4) The standard Rules and Regulations of the Company as on file from time to time with the Arizona Corporation Commission shall apply where not inconsistent with this rate schedule.
- (5) The requirement for service shall not exceed the nameplate capacity of the QF.
- (6) The frequency and duration of service may be limited so that the rates remain compensatory by ensuring that usage retains the characteristics of partial requirements service.
- (7) A detented meter will be used for service supplied under this schedule.
- (8) A contribution in aid of construction will be required for any investment in metering equipment in excess of \$1800.

# NEW & RETROFIT CONSTRUCTION REBATE SCHEDULE

## Compact Fluorescent

<u>Lamp Wattage</u>	<u>Rebate</u>
5-W to 10-W	\$3.00
11-W to 26-W	\$5.00

## Fluorescent Lamps

<u>Lamp Type</u>	<u>Rebate</u>
17-W (T-8)	\$0.50*
32-W (T-8)	\$1.00*
59-W (8 foot T-8)	\$1.00*
40-W (T-10)	\$1.50**
GE Staybright XL	\$1.50**

\* Dedicated T-8 ballasts required.

\*\* Rebates for T-10 and GE Staybright lamps are only available in retrofit applications where the number of lamps per fixture is reduced. All disconnected ballasts, lamps and lamp holders must be removed from the fixture. All remaining lamp holders and lamps must be re-positioned for maximum fixture efficiency. The number of ballasts installed to operate the new system must be at least 30% lower than the original number of ballasts.

## Ballasts

<u>Ballast Type</u>	<u>Rebate</u>
Non T-8 Electronic	\$4.00
Hybrid	\$4.00
T-8 Electronic	\$8.00
T-8 Dimmable Electronic	\$10.00

Electronic ballasts must operate at 20 kHz or greater. A Hybrid ballast is defined as a 60-cycle output ballast with cathode heat cut-out. All ballasts must be listed and UL-approved, have a minimum power factor of 95% and a Total Harmonic Distortion (THD) of 20% or less. Dimmable ballasts must have totally automatic dimming through photocells, timers or energy management system. Manual override controls should not be easily accessible.

## Reflectors

<u>Size</u>	<u>Rebate</u>
2X2 Reflector	\$4.00
2X4 or 1X8 Reflector	\$8.00

Reflectors must be UL-approved, custom designed, rigid metallic inserts in existing fixtures. Rebates are only available in retrofit applications where the number of lamps per fixture is reduced. All disconnected ballasts, lamps and lamp holders must be removed from the fixture. All remaining lamp holders and lamps must be re-positioned for maximum fixture efficiency. The number of ballasts installed to operate the new system must be at least 30% lower than the original number of ballasts.

**Please Turn Over**

## Occupancy Sensors & Timers

<u>Type</u>	<u>Rebate</u>
Controlling 2-4 fixtures	\$4.00
Controlling 5 or more fixtures	\$8.00

Occupancy sensors must not have a readily accessible manual "on" switch and must be UL-approved.

## Exit Signs

<u>Type</u>	<u>Rebate</u>
Fluorescent Retrofit	\$6.00
LED	\$9.00

Must replace a system of at least 30 watts. Must be UL-approved as an entire unit and must comply with all applicable building safety and fire codes. It is the customer's responsibility to check compliance.

## HID Fixture Conversions

*(Indoor High Pressure Sodium & Metal Halide Retrofit Only)*

<u>Type</u>	<u>Rebate</u>
HID Retrofit	\$100/kW reduced

HID retrofit designs will qualify for the rebate on a case by case basis. Submit all existing and proposed lighting system information on the *Supplemental Application*. All equipment used must be UL-approved and meet all safety requirements of the space the equipment is installed in. Total rebate amount not to exceed 40% of the installed equipment cost.

For more information or to schedule a *FREE* lighting analysis,  
call your TEP Representative at 745-3538.

**1994 TOTALLY ENCLOSED FAN COOLED HIGH-EFFICIENCY MOTOR REBATE SCHEDULE**

MOTOR HP	MINIMUM QUALIFYING EFFICIENCY				BASE REBATE				BONUS FACTOR
	900 RPM	1200 RPM	1800 RPM	3600 RPM	900 RPM	1200 RPM	1800 RPM	3600 RPM	
5	85.5	87.5	87.5	87.5	\$20	\$35	\$35	\$35	\$10 per %
7.5	85.5	89.5	89.5	89.5	\$35	\$50	\$50	\$45	\$15 per %
10	88.5	89.5	89.5	89.5	\$40	\$40	\$40	\$40	\$15 per %
15	88.5	90.2	91.0	90.2	\$60	\$60	\$60	\$60	\$15 per %
20	89.5	90.2	91.0	90.2	\$65	\$50	\$55	\$50	\$25 per %
25	89.5	91.7	92.4	91.0	\$85	\$80	\$85	\$65	\$30 per %
30	91.0	91.7	92.4	91.0	\$75	\$70	\$80	\$65	\$35 per %
40	91.0	93.0	93.0	91.7	\$145	\$155	\$145	\$105	\$55 per %
50	91.7	93.0	93.0	92.4	\$85	\$100	\$85	\$60	\$35 per %
60	91.7	93.6	93.6	93.0	\$190	\$200	\$180	\$180	\$100 per %
75	93.0	93.6	94.1	93.0	\$210	\$190	\$200	\$150	\$100 per %
100	93.0	94.1	94.5	93.6	\$290	\$280	\$290	\$280	\$130 per %
125	93.6	94.1	94.5	94.5	\$645	\$325	\$355	\$675	\$300 per %
150	93.6	95.0	95.0	94.5	\$545	\$635	\$545	\$635	\$300 per %
200	94.1	95.0	95.0	95.0	\$510	\$600	\$425	\$595	\$425 per %

**1994 OPEN DRIP PROOF HIGH-EFFICIENCY MOTOR REBATE SCHEDULE**

MOTOR HP	MINIMUM QUALIFYING EFFICIENCY				BASE REBATE				BONUS FACTOR
	900 RPM	1200 RPM	1800 RPM	3600 RPM	900 RPM	1200 RPM	1800 RPM	3600 RPM	
5	87.5	87.5	87.5	85.5	\$15	\$15	\$15	\$10	\$5 per %
7.5	88.5	88.5	88.5	87.5	\$40	\$30	\$35	\$35	\$10 per %
10	89.5	90.2	89.5	88.5	\$40	\$35	\$40	\$35	\$10 per %
15	89.5	90.2	91.0	89.5	\$55	\$40	\$50	\$55	\$15 per %
20	90.2	91.0	91.0	90.2	\$60	\$55	\$60	\$40	\$20 per %
25	90.2	91.7	91.7	91.0	\$70	\$65	\$55	\$60	\$20 per %
30	91.0	92.4	92.4	91.0	\$70	\$75	\$70	\$65	\$25 per %
40	91.0	93.0	93.0	91.7	\$85	\$85	\$90	\$70	\$35 per %
50	91.7	93.0	93.0	92.4	\$95	\$95	\$100	\$95	\$40 per %
60	92.4	93.6	93.6	93.0	\$120	\$105	\$110	\$130	\$40 per %
75	93.6	93.6	94.1	93.0	\$105	\$85	\$105	\$90	\$45 per %
100	93.6	94.1	94.1	93.0	\$125	\$125	\$115	\$120	\$55 per %
125	93.6	94.1	94.5	93.6	\$155	\$175	\$185	\$120	\$110 per %
150	93.6	94.5	95.0	93.6	\$230	\$230	\$295	\$255	\$135 per %
200	93.6	94.5	95.0	94.5	\$335	\$335	\$420	\$465	\$210 per %

Air Cooled Unitary AC			
Capacity	High Efficiency EER	Rebate per Ton	Additional Rebate per 0.1 EER
< 65,000 Btuh	11.0	\$29	\$2
≥65,000 < 135,000	10.0	\$21	\$2
≥135,000 < 760,000	9.5	\$18	\$2
> 760,000 Btuh	9.5	\$28	\$2

Water Cooled Unitary AC			
Capacity	High Efficiency EER	Rebate per Ton	Additional Rebate per 0.1 EER
< 65,000 Btuh	11.0	\$35	\$2
≥65,000 < 135,000	11.5	\$15	\$2
≥135,000 < 760,000	10.5	\$17	\$2
> 760,000 Btuh	10.5	\$17	\$2

Air Cooled Unitary Heat Pump			
Capacity	High Efficiency EER	Rebate Per Ton	Additional Rebate Per 0.1 EER
< 65,000 Btuh	11.0	\$32	\$2
≥65,000 < 135,000	9.5	\$11	\$2
≥135,000 < 760,000	9.1	\$18	\$2
> 760,000 Btuh	9.1	\$28	\$2

Water Cooled Unitary Heat Pump			
Capacity	High Efficiency EER	Rebate Per Ton	Additional Rebate Per 0.1 EER
< 65,000 Btuh	11.5	\$40	\$2
≥65,000 < 135,000	11.5	\$20	\$2
≥135,000 < 760,000	10.5	\$21	\$2
> 760,000 Btuh	10.5	\$21	\$2

Water Cooled Chillers			
Capacity	High Efficiency kW/ton	Rebate Per Ton	Additional Rebate Per 0.01 kW/ton
<b>Centrifugal</b>			
< 150 Tons	0.67	\$10.00	\$2.00
≥ 150 < 300	0.65	\$10.00	\$2.00
≥ 300 < 500	0.60	\$10.00	\$2.00
> 500	0.60	\$10.00	\$2.00
<b>Rotary</b>			
< 150 Tons	0.70	\$10.00	\$2.00
≥ 150 < 300	0.67	\$10.00	\$2.00
≥ 300	0.65	\$10.00	\$2.00
<b>Reciprocating</b>			
≤ 60 Tons	0.80	\$10.00	\$2.00
> 60 ≤ 150	0.75	\$10.00	\$2.00
>150 ≤ 300	0.70	\$10.00	\$2.00

Air Cooled Chillers			
Capacity	High Efficiency kW/ton	Rebate Per Ton	Additional Rebate Per 0.01 kW/ton
<b>Centrifugal</b>			
< 150 Tons	NOT APPLICABLE		
≥ 150 < 300			
≥ 300 < 500			
> 500			
<b>Rotary</b>			
< 125 Tons	1.00	\$10.00	\$2.00
>= 150 < 300	n/a	n/a	n/a
>= 300	n/a	n/a	n/a
<b>Reciprocating</b>			
≤ 60 Tons	1.00	\$10.00	\$2.00
> 60 ≤ 150	n/a	n/a	n/a
>150 ≤ 300	n/a	n/a	n/a

**CG-55 Gas Service for**

**Compression—Large**

Customers whose compression equipment is rated above 30 cubic feet per minute or who receive service at pressure above 5 pounds per square inch.

Basic Service Charge per Month.....\$100.00  
Commodity Charge per Therm  
All Usage.....\$.35709

**CG-60 Cogeneration Gas Service**

Commodity Charge per Therm  
All Usage.....\$.26869  
1 J U L Y ' 9 4 \$ 0 . 2 6 1 6 3

**CG-75 Essential Agricultural Gas Service—Small**

Essential agricultural customers using less than 1,250,000 therms per year.

Basic Service Charge per Month.....\$ 25.00  
Commodity Charge per Therm  
All Usage.....\$.43596

**CG-80 Natural Gas Engine Gas Service**

Basic Service Charge per Month.....\$ 25.00  
Commodity Charge per Therm  
All Usage.....\$.36834

**CG-81 Irrigation Pumping Gas Service**

Agricultural irrigation pumping customers who qualify for service under Schedule No. CG-80.

Basic Service Charge per Month  
Off-Peak Season (Oct.-Mar.).....\$ 6.00  
Peak Season(Apr.-Sept.).....\$ 25.00  
Commodity Charge per Therm  
All Usage.....\$.38020

**CG-90 Electric Generation Gas Service**

Basic Service Charge per Month.....\$5,725.00  
Commodity Charge per Therm  
All Usage.....\$.29072  
1 J U L Y ' 9 4 \$ 0 . 2 7 1 3 9

**CG-95 Resale Gas Service**

Basic Service Charge per Month.....\$500.00  
Commodity Charge per Therm  
All Usage.....\$.24468

# SOUTHWEST GAS CORPORATION

## Central Arizona Division

- Residential Service
- General Service
- Air-Conditioning Service
- Compressed Natural Gas Service
- Cogeneration Service
- Natural Gas Engine Service



Effective March 16, 1994

SW5268 (03/94)

### Southwest Gas Corporation

As a result of Southwest's recent purchased gas adjustment proceeding, Southwest has been authorized by the Arizona Corporation Commission to increase natural gas rates to its Central Arizona Division customers effective March 16, 1994.

The new sales rates are listed by customer class.

For additional information call Southwest at the telephone number listed on the front of your bill.

#### CG-5 Residential Gas Service

Basic Service Charge per Month.....\$ 5.50  
Commodity Charge per Therm  
All Usage.....\$.65416

#### CG-10 Low Income Residential Gas Service

Residential customers with household incomes less than 150 percent of the Federal poverty level.

Basic Service Charge per Month.....\$ 5.50  
Commodity Charge per Therm  
Summer (April-October)  
All Usage.....\$.65416  
Winter (November-March)  
First 100 Therms.....\$.55604  
Over 100 Therms.....\$.65416

#### CG-15 Special Residential Gas Service

Residential customers with installed gas air conditioning and residential customers formerly served under Schedule No. PG-15.

Basic Service Charge per month.....\$ 5.25  
Demand Charge per Month:  
Peak Winter Month Usage Times  
Demand Charge per Therm.....\$ .08  
Commodity Charge per Therm  
All Usage.....\$.39436

#### CG-20 Master-Metered Mobile Home Park Gas Service

Basic Service Charge per Month.....\$ 15.00  
Commodity Charge per Therm  
All Usage.....\$.55356

#### CG-25 General Gas Service—Small

Commercial and industrial customers using less than 7,200 therms per year.  
Basic Service Charge per Month.....\$ 15.00  
Commodity Charge per Therm  
All Usage.....\$.55280

#### CG-25 General Gas Service—Medium

Commercial and industrial customers using between 7,200 therms per year and 180,000 therms per year.  
Basic Service Charge per Month.....\$100.00  
Commodity Charge per Therm  
All Usage.....\$.48329

#### CG-25 General Gas Service—Large

Commercial and industrial customers using more than 180,000 therms per year.

Basic Service Charge per Month.....\$750.00  
Commodity Charge per Therm  
All Usage.....\$.41115

#### CG-35 Gas Service to Armed Forces

Basic Service Charge per Month.....\$100.00  
Commodity Charge per Therm  
All Usage.....\$.42758

#### CG-40 Air-Conditioning Gas Service

Commercial and industrial customers with installed gas air conditioning.

Commodity Charge per Therm  
All Usage.....\$.33352

#### CG-45 Street Lighting Gas Service

Commodity Charge per Therm  
of Rated Capacity  
All Usage.....\$.68469

#### CG-55 Gas Service for

##### Compression—Small

Customers whose compression equipment is rated at 30 cubic feet per minute or less and who receive service at pressure of 5 pounds per square inch or less  
Basic Service Charge per Month.....\$ 15.00  
Commodity Charge per Therm  
All Usage.....\$.3653E



**Energy Costs and Life Cycle Analysis Factors for Prefinal Submittal  
Energy Saving Opportunity Survey of Fort Huachuca, Az**

**Single Cash Flow Discount Factors**

SPW year	1	0.971
	2	0.943
	3	0.915
	4	0.888
	5	0.863
	6	0.837
	7	0.813
	8	0.789
	9	0.766
	10	0.744
	11	0.722
	12	0.701
	13	0.681
	14	0.661
	15	0.642

**APPENDIX C**

**Motor Survey Data and Retrofit Calculations**

**APPENDIX C**  
**Table of Contents**

Survey Methodology . . . . .	C-1
Energy-Efficient Motor Retrofit Evaluations . . . . .	C-1
Table C-1 Summary of Motor Nameplate and Test Data . . . . .	C-3
Table C-2 Summary of Energy-Efficient Motor Retrofit Evaluations . . . . .	C-4
Table C-3 Energy-Efficient Motor Retrofit Costs . . . . .	C-5



## APPENDIX C Motor Survey Data and Retrofit Calculations

### Survey Methodology

The survey was limited to motors with a rated horsepower of 5HP or more since units below this size do not qualify for utility company rebates and have little likelihood of a cost-effective retrofit.

Performance data collected included operating speed RPM using a digital tachometer; and input voltage, input current and power factor using clamp-on instruments.

A summary of motor nameplate data and performance data collected during the field investigation appears in Table C-1.

### Energy-Efficient Motor Retrofit Evaluations

The following data and assumptions were used to evaluate the feasibility of replacing existing motors with energy-efficient units:

- Efficiency improvements between standard and energy-efficient motors are valid at partial loads since energy-efficient motors operate at higher partial-load efficiencies than standard motors.
- The replacement energy-efficient electric motor will match the full-load speed of the replaced standard motor.
- Efficiencies of energy-efficient motors were based on averages provided in the DOE "Energy-Efficient Electric Motor Selection Handbook, Revision 3," January 1993. In instances where the average energy-efficient motor efficiency was less than the minimum required to qualify for a TEP rebate, the rebate-qualifying efficiency was used.
- Motor costs were based on the list price averages provided in the DOE motor handbook, adjusted for inflation and a contractor's discount.

The following formulae were used in the spreadsheet calculations summarized in Table C-2:

$$\text{Savings, kW} = \left( \frac{1}{\text{Existing Efficiency}} - \frac{1}{\text{New Efficiency}} \right) \times \text{Estimated Load Factor} \times \text{Motor HP} \times 0.746 \text{ kW/HP}$$

$$\text{Savings, kWh} = \text{Savings kW} \times \text{Op. Hours/Month} \times \text{Op. Months/Year}$$

$$\text{Savings, \$/Year} = (\text{Savings, kWh} \times \$0.04835) + \left( \text{Savings, kW} \times \frac{\text{Op. Months/Year}}{12} \times \$127.84/\text{kW/Year} \right)$$

$$\text{Savings, LCC\$} = \text{Savings, \$/Year} \times 15.08 \text{ UPV Factor for 20 year life}$$



Construction Cost: From Table C-3

SIOH & Design = Construction Cost x 0.12

TEP Rebate: From schedule in Appendix B

Total Investment = Construction Cost + SIOH & Design - TEP Rebate

SIR = Savings LCC\$ ÷ Total Investment



**TABLE C-1. SUMMARY OF MOTOR NAMEPLATE AND TEST DATA**

Building No.	Nameplate Data				Measured Data				Calculated Values								
	Equipment	Motor Manufacturer	Motor HP	Voltage Rating	Enclosure Type (1)	Frame Size	Existing Efficiency	Full Load Speed, RPM	Input Volts Avg.	Input Amps Avg.	P. F.	Input Speed RPM	Operating Slip	Load Factor	HP Output	Input kW	Input kVA
15544	SA Fan HVAC Unit	BALDOR	20	230	TEFC	256T	0.930	1760	208	41.5	0.87	1773.0	27	0.88	13.50	10.02	14.95
43083	SA Fan AHU No. 1	MARATHON	7.5	200	ODP	213T	0.853 (2)	1755	200	23.3	0.7	1766.3	33.7	0.75	5.62	5.65	8.07
43083	SA Fan AHU No. 2	DAYTON	7.5	230	ODP	213T	0.853 (2)	1740	210	12.6	0.55	1784.5	15.5	0.26	1.94	2.52	4.58
53301	SA Fan HVAC Unit	CENTURY	30	460	ODP	S286T	0.924	1760	487.3	17.1	0.80	1790.7	9.3	0.23	6.97	8.68	14.46
53301	SA Fan	CENTURY	60	460	ODP	326T	0.930	1770	487.3	26.2	0.59	1794.5	5.5	0.18	9.17	13.06	22.14
56301	CHW Circ. Pump 1	BALDOR	5	460	ODP	184T	0.815	1725	NA	NA	NA	NA	NA	NA	NA	NA	NA
56301	CHW Circ. Pump 2	NA	5	460	ODP	NA	0.838	1750	NA	NA	NA	NA	NA	NA	NA	NA	NA
56301	SA Fan, North HVAC Unit	NA	10	460	ODP	NA	0.872 (2)	1760	NA	NA	NA	NA	NA	NA	NA	NA	NA
56301	SA Fan, Central HVAC Unit	NA	10	460	ODP	NA	0.872 (2)	1760	NA	NA	NA	NA	NA	NA	NA	NA	NA
56301	SA Fan, South HVAC Unit	NA	10	460	ODP	NA	0.872 (2)	1760	NA	NA	NA	NA	NA	NA	NA	NA	NA
56301	Condenser Fan 1	NA	7.5	460	ODP	NA	0.853 (2)	1760	NA	NA	NA	NA	NA	NA	NA	NA	NA
56301	Condenser Fan 2	NA	7.5	460	ODP	NA	0.853 (2)	1760	NA	NA	NA	NA	NA	NA	NA	NA	NA
57305	CHW Circ. Pump 2	US ELECT MTRS	25	460	TEFC	324T	0.895	NA	477.7	22.2	0.81	1189.0 (3)	NA	NA	NA	14.88	18.37
61701	Pool Circ. Pump	BALDOR	20	230	ODP	286U	0.895	1760	212.0	51.6	0.86	1765.0	35	0.88	17.50	16.28	18.94
62704	RA Fan	GOULD	10	460	ODP	S215T	0.872 (2)	1750	485.3	10.1	0.58	1767.2	32.8	0.66	6.56	4.92	8.49
62704	SA Fan	GOULD	25	460	ODP	284T	0.892 (2)	1750	484.7	20.7	0.59	1784.2	16.8	0.32	7.90	10.25	17.38
67601	AHU 1 SA Fan	MAGNATEK	15	460	ODP	S256T	0.860	1760	NA	NA	NA	NA	NA	NA	NA	NA	NA
67601	AHU 2 SA Fan	MAGNATEK	15	460	ODP	S256T	0.860	1760	484.7	14.5	0.58	1785.1	14.9	0.37	5.59	7.06	12.17
67601	AHU 3 SA Fan	MAGNATEK	15	460	ODP	S256T	0.860	1760	482.0	13.3	0.50	1194.4 (3)	NA	NA	NA	5.55	11.10
67601	AHU 4 SA Fan	MAGNATEK	15	460	ODP	S256T	0.860	1760	NA	NA	NA	NA	NA	NA	NA	NA	NA
67601	AHU 5 SA Fan	MAGNATEK	15	460	ODP	S256T	0.860	1760	483.3	14.1	0.44	1789.5	10.5	0.26	3.94	5.20	11.83
67601	AHU 6 SA Fan	MAGNATEK	15	460	ODP	S256T	0.860	1760	484.7	14.7	0.57	1782.0	18	0.45	6.75	7.05	12.37
67601	AHU 7 SA Fan	MAGNATEK	15	460	ODP	S256T	0.860	1760	484.7	14.7	0.57	1782.0	18	0.45	6.75	7.05	12.37
67601	HVAC Sys. Circ. Pump	UNIMOUNT	15	460	ODP	NA	0.895	NA	485.3	13.4	0.69	1785.7	14.3	NA	NA	7.77	11.26
70525	Furnace SA Fan	LINCOLN	10	200	TEFC	256-U	0.860 (2)	1740	203.2	16.4	0.11	1775.0	25	0.42	4.17	0.84	5.78
80505	CHWP-1	US ELECT MTRS	15	460	ODP	254T	0.875	1745	NA	NA	NA	NA	NA	NA	NA	NA	NA
80505	CHWP-2	US ELECT MTRS	15	460	ODP	254T	0.875	1745	471.1	13.1	0.54	1780.5	19.5	0.35	5.32	5.77	10.69
80505	HWP-1	US ELECT MTRS	7.5	460	ODP	213T	0.840	1740	467.6	7.0	0.40	1787.0	33	0.55	4.13	2.28	5.69
80505	Fan Coil Unit, Rm 249	NA	7.5	460	NA	NA	0.852 (2)	NA	NA	7.8	0.70	NA	NA	NA	NA	4.42	6.32
80505	Fan Coil Unit, Rm 213	WEQ	5	460	TEFC	NA	0.833 (2)	1740	467.6	4.9	0.80	1743.0	57	0.95	4.75	3.19	3.99
80505	VAVH2 West, Roof FCU	MAGNATEK	15	460	ODP	S254T	0.895	1750	467.6	10.4	0.35	1792.0	8	0.16	2.40	2.94	8.40
80505	VAVH2, Roof FCU	MAGNATEK	15	460	ODP	S254T	0.895	1750	NA	NA	NA	NA	NA	NA	NA	NA	NA
80505	SA Fan East	MAGNATEK	30	460	ODP	S286T	0.883	1750	467.6	18.8	0.60	1450.0 (3)	NA	NA	NA	9.12	15.20
80505	SA Fan West	MAGNATEK	30	460	ODP	S286T	0.883	1750	NA	NA	NA	NA	NA	NA	NA	NA	NA
80505	RA Fan East	MAGNATEK	10	460	ODP	S215T	0.856	1750	474.6	9.2	0.45	1719.0 (3)	NA	NA	NA	3.39	7.54
80505	RA Fan West	MAGNATEK	10	460	ODP	S215T	0.856	1750	NA	NA	NA	NA	NA	NA	NA	NA	NA
91114	HW Circ. Pump	US ELECT MTRS	5	200	ODP	184JM	0.815	1730	204.7	13.6	0.86	1731.0	69	0.99	4.93	4.15	4.82

NA - Data Not Available  
 (1) ODP = Open Drip Proof  
 TEFC = Totally Enclosed Fan-Cooled  
 (2) Assumed Value, Based on Average Standard Motor Efficiencies  
 (3) Motor Operated by Variable Speed Drive



TABLE C - 3. ENERGY EFFICIENT MOTOR RETROFIT COSTS

Motor Size HP	Manhours	Cost \$ {1}	ODP Material Cost \$ {2}	TEFC Material Cost \$ {2}	ODP Construction Cost \$ {3}	TEFC Construction Cost \$ {3}	Motor Size HP
5	3.6	76	197	269	\$391	\$496	5
7.5	3.8	80	245	388	\$466	\$673	7.5
10	4.0	85	309	468	\$566	\$796	10
15	5.0	106	406	625	\$736	\$1,053	15
20	6.1	129	506	761	\$913	\$1,282	20
25	6.4	135	596	925	\$1,051	\$1,528	25
30	6.7	142	696	1,095	\$1,206	\$1,784	30
40	8.0	169	867	1,404	\$1,491	\$2,269	40
50	10.0	212	1,013	1,729	\$1,763	\$2,799	50

{1} \$21.15/Hr Electrician per Means Bare Trade Rate, adjusted for location  
Labor - Use 2 x Means Manhours

{2} Averages from "DOE Energy Efficient Electric Motor Handbook Rev. 3"  
Jan. 1993 Escalated from 1990 Prices = (1 Jan. '94 Index/1 Jan. '90 Index) = (1887/1676)  
Reduced by 40% to Equal 'Supply' Contractor Price, Therefore  
Average List Price Multiplier = (0.60)(1887/1676) = 0.676

{3} Construction Cost = {Labor Cost + (Mat'l Cost x 1.0375)} x 1.25 OH & P  
x 1.015 Bond x 1.10 Contingency

**APPENDIX D**  
**Table of Contents**

Existing Chiller Energy Use . . . . .	D-1
Proposed Gas-Engine-Driven Chiller Energy Use . . . . .	D-2
Operating and Maintenance Costs . . . . .	D-2
Analysis Results . . . . .	D-2
Construction Cost Estimate . . . . .	D-3
Life Cycle Cost Analysis Summary . . . . .	D-4
Manufacturer's Data Sheets . . . . .	D-5



## Natural Gas Cooling for CETEC Communications Equipment Facility Building 56301

Building cooling is presently provided by an air cooled reciprocating chiller serving rooftop multi-zone air handling units.

The existing electric powered chiller has a capacity of about 80 Tons and serves a design cooling load of 69 Tons; the chiller's maximum electric power demand is 67.0 kW.

The possibility of replacing the existing electric powered chiller with a natural gas powered chiller is investigated. Three types of natural gas powered chillers are available:

- Direct Fired Absorption Chillers
- Hot Water Heated Absorption Chillers
- Gas Engine-Driven Chillers

The possibility of installing an absorption chiller to be used in conjunction with the hot water output from the hot water boiler in building 56301 was investigated, and found not to be feasible. Trane, Carrier, and York absorption chillers were investigated. It was determined that the hot water output from the boiler will not attain the minimum input temperature required. The minimum input water temperature required, according to catalog information, is 240°F, whereas the maximum output temperature from the boiler is controlled at approximately 182°F.

Use of a direct fired absorption chiller was also considered. The smallest capacity offered is about 100 tons, too large for building 56301.

Gas engine driven chillers available as packaged systems from Tecochill and Enchill are considered.

### Existing Chiller Energy Use

Power consumption data is not available for the building. Existing cooling energy use is calculated based on installed equipment capacity and building envelope data.

Capacities of installed air handling systems are as follows:

<u>Unit Description</u>	<u>Sensible BTUH</u>	<u>Total BTUH</u>
ACU/ACCU 1	48,300	56,820
AH1	240,440	253,095
AH2	248,760	261,860
AH3	240,550	253,210
<u>Totals</u>	<u>778,050</u>	<u>824,985</u>

Assuming capacity is selected at about 10% over the actual zone loads, the block cooling load is, thus:  
907,484 BTUH, or 76 Tons.

The Cooling Load Temperature Difference for the building is found to be about 15.14 °F, based on envelope data. The annual cooling-degree-days from the Fort Huachuca Meteorological Team report dated November 30, 1992 are: 1,595 Cooling-Degree-Days per Year.

The annual cooling load is, thus estimated at 2,294 Million BTU per Year.

Based on vendor information for the existing chiller, energy use is based on: 1.4 kW/Ton; annual

power consumption is, thus: 267,690 kWh per Year.

Electric Power Demand is charged at: \$10.65 per kW per month including applicable taxes and the effects of Fort Huachuca's high power factor.

Electric Power use is charged at: \$0.04835 per kWh including applicable taxes.

Annual power cost to operate the existing chiller is, thus: \$21,508 per year including demand & use charges.

### Proposed Gas Engine Driven Chiller Energy Use

The proposed gas engine driven chiller is:

ENCHILL Model ECA 70 G: HCFC R-22 Refrigerant  
72 Tons nominal capacity  
87 HP Engine  
1.21 HP/Ton  
7.21 Therms/Hour gas consumption  
1.21 C.O.P.

Full load operating hours, based on the above load calculations: 2,528 Hours per Year.

Fuel consumption based on chiller performance data: 1,823 Million BTU per Year

Natural Gas rate for gas engine driven systems offered by Southwest Gas Corporation under Schedule CG-35.  
\$4.2758 per Million BTU. Applicable taxes per current billings add an additional 5.430%  
for an overall natural gas cost of \$4.5080 per Million BTU.

Annual energy cost for operating a gas engine driven chiller are: \$8,218 per year.

### Operating and Maintenance (O&M) Costs

Based on a recent paper appearing in Energy Engineering, Vol. 91, No. 2, 1994, by D. J. Anderson, operating costs for the existing chiller and proposed engine driven chiller are:

80 Ton Existing:	\$0.0075 per Ton per Hour x	2,528 Hours =	\$1,517 per Year.
72 Ton Proposed:	\$0.0140 per Ton per Hour x	2,528 Hours =	\$2,549 per Year.

### Analysis Results

Installation costs are estimated on the next page

Life cycle cost analysis resulted in the following measures for a 15 year economic life.

Simple Payback Period:	9.99 Years
Savings to Investment Ratio (SIR):	1.06
Adjusted Internal Rate of Return (AIR)	4.90%

The proposed project is marginally economically attractive and should be considered for implementation.



**Life Cycle Cost Analysis Summary  
Energy Conservation Investment Program (ECIP)**

Location: Fort Huachuca, Arizona      Region No. 4      Project No.  
 Project Title: ECIP Facility Energy Improvements      Fiscal Year FY96  
 Discrete Portion: Building 56301 Gas Engine Driven Chiller Retrofit      Preparer: KELLER & GANNON  
 Analysis Date: August 1994      Economic Life: 15 Years

**1. Investment Costs**

A. Construction Costs	<u>\$109,385</u>	
B. SIOH	<u>\$6,563</u>	
C. Design Cost	<u>\$6,563</u>	
D. Total Cost (1A+1B+1C)	<u>\$122,512</u>	
E. Salvage Value of Existing Equipment		<u>\$0</u>
F. Public Utility Company Rebate		<u>\$0</u>
G. Total Investment (1D-1E-1F)		\$122,512

**2. Energy Savings (+)/Cost(-):**

Date of NISTIR 85-3273 Used for Discount Factors: October 1994

Energy Source	Cost \$/MBTU	Saving MBTU/Yr(2)	Annual \$ Savings(3)	Discount Factor(4)	Discounted Savings(5)
A. Elec.	<u>\$14.17</u>	<u>914</u>	\$12,943	<u>12.02</u>	\$155,572
B. Dist	<u>\$13.25</u>	<u>0</u>	\$0	-	\$0
C. LPG	<u>\$7.37</u>	<u>0</u>	\$0	-	\$0
D. Natural Gas	<u>\$4.51</u>	<u>(1,823)</u>	(\$8,218)	<u>14.17</u>	(\$116,449)
E. Demand Saved	<u>\$127.84</u>	<u>67.0 kW</u>	<u>\$8,565</u>	<u>12.02</u>	<u>\$102,955</u>
F. Total		<u>(909)</u>	<u>\$13,290</u>		<u>\$142,078</u>

**3. Non Energy Savings (+) or Cost (-):**

A. Annual Recurring (+/-)	<u>(\$1,032)</u>	
(1) Discount Factor (Table A)		<u>11.94</u>
(2) Discounted Savings/Cost (3A x 3A1)		(\$12,317)

**B. Non Recurring Savings (+) or Cost (-)**

Item	Savings(+) Cost(-)(1)	Year of Occur. (2)	Discount Factor(3)	Discounted Savings(+) Cost(-)(4)
a.	_____	_____	_____	_____
b.	_____	_____	_____	_____
c.	_____	_____	_____	_____
d. Total				

C Total Non Energy Discounted Savings (3A2 + 3Bd4)      (\$12,317)

4. Simple Payback 1G/(2F3 + 3A + (3Bd1/Economic Life)):	9.99	Years
5. Total Net Discounted Savings (2F5 + 3C):	\$129,761	
6. Savings to Investment Ratio (SIR) 5/1G:	1.06	
7. Adjusted Internal Rate of Return (AIRR):	4.9%	

# ENCHILL by MKW

## ENGINE DRIVEN CHILLERS

NATURAL GAS ENGINE  
 RECIPROCATING  
 COMPRESSOR  
 AIR-COOLED CONDENSING

**Standard Components and Features:**

- Heavy Duty Industrial Engine
- Industrial Grade High Efficiency Reciprocating Compressor
- Refrigerant HCFC R-22
- Fully Insulated Evaporator
- Automatic Microprocessor Controls/Monitor
- Torsional Coupling
- Automatic Lube Oil Make-up System.
- Heat Exchanger for Engine Cooling
- Engine Exhaust Gas Silencer
- Starting Batteries, Rack and Cable
- Static Battery Charger
- Flex Connectors for Gas and Engine Exhaust
- Spring Vibration Isolators
- Complete Manuals for Installation and Operation of the System
- One Year Parts Warranty

**Optional Equipment and Services:**

- Sound Attenuated Metal Enclosure
- Heat Recovery System for Engine Jacket and Exhaust
- Exhaust Gas Catalytic Converter
- Diesel or Propane Fueled Engine
- Constant or Variable Speed Control
- Custom Control or Remote Monitoring
- Installation/Start-up Supervision

**MODEL NUMBER**

**ECA 70 G**

**TONNAGE: 72 (CONTINUOUS)**

**Refrigerant: HCFC R-22**

**Horsepower: 87**

**Horsepower/Ton: 1.21**

**Fuel Input: 7.21 Therms/Hour**

**C.O.P. (w/losses) 1.20 \*\***

Available Heat (optional): 3.48

Therms/Hour

C.O.P. (w/heat recovery): 1.68 \*\*

**CONDENSER SPECIFICATION**

Air-Cooled 120° F Condensing  
 Temperature

**EVAPORATOR SPECIFICATION**

Flow @ 55° to 45° F = 173 GPM  
 Pressure Drop @ .00025 ff = 13 ft.  
 H<sub>2</sub>O

**\*\*Coefficient Of Performance (C.O.P.) uses Higher Heating Value (HHV) for the fuel input and includes all losses.**

**Weights and Dimensions:**

WEIGHT	L	W	H
5,600 (lb.)	130	88	72 (inches)

Note: Specifications are subject to change without notice and are within +/- 5%.

**ENCHILL** Sales & Marketing, 785 Grand Avenue, Suite 206, Carlsbad, California 92008  
 PHONE: (619) 720-1500 FAX: (619) 720-0070

EASTERN/GULF OFFICE: 1602 Pineland Street, Longview, TX 75604 PHONE: (903) 295-1810 FAX: (903) 295-1812

**EQUIPMENT LIST**

- (A) RECIPROCATING COMPRESSOR
- (B) TORSIONAL COUPLING
- (C) INDUSTRIAL GAS ENGINE
- (D) REFRIGERANT DRYER
- (E) EVAPORATOR
- (F) ENCHILL MICROPROCESSOR CONTROLS

**DIMENSIONS (INCHES)**

MODEL	LENGTH	WIDTH	HEIGHT
ECA-65-G	150	62	72
ECA-70-G	150	68	72
ECA-100-G	145	92	72
ECA-130-G	145	98	72

**CUSTOMER POINTS OF CONNECTION**

- 1 CHILLED WATER INLET
- 2 CHILLED WATER OUTLET
- 3 REFRIGERANT SUPPLY TO AIR COOLED CONDENSER
- 4 REFRIGERANT RETURN FROM AIR COOLED CONDENSER
- 5 ENGINE EXHAUST
- 6 RADIATOR SUPPLY
- 7 RADIATOR RETURN
- 8 NATURAL GAS INLET
- 9 LUBE OIL MAKE-UP
- 10 MOUNTING HOLES

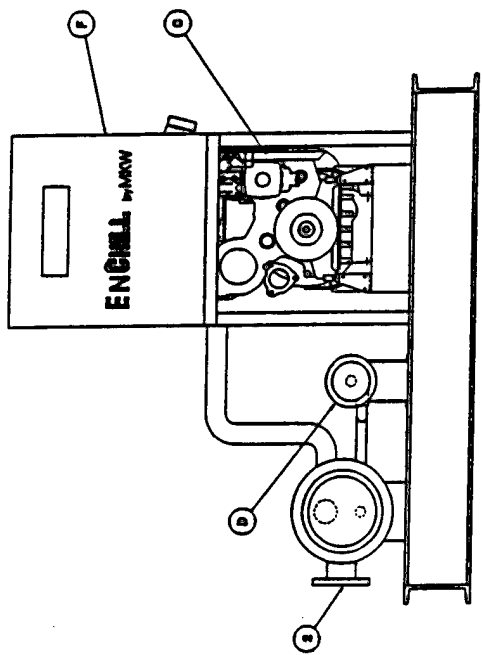

ENGINE DRIVEN CHILLER

ENGINE SKID ASSEMBLY  
FRONT ELEVATION

SCALE: 1/8" = 1'-0"

**A - 1**

REVISIONS

NO.	DATE	DESCRIPTION
1	11/14/94	REVISED
2	01/14/94	REVISED

**ENCHILL** by MKW

ENGINE DRIVEN CHILLERS

785 GRAND AVENUE, SUITE 208  
CARLSBAD, CA 92008

**BLS**

ENGINEERING CONSULTANTS, INC.

DATE: 11/14/94

BY: [Signature]

CHECKED: [Signature]

PROJECT: [Blank]

DESCRIPTION: [Blank]

DATE: [Blank]

BY: [Blank]

CHECKED: [Blank]

**EQUIPMENT LIST**

- (A) RECIPROCATING COMPRESSOR
- (B) TOPSONAL COUPLING
- (C) INDUSTRIAL GAS ENGINE
- (D) REFRIGERANT DRIVER
- (E) EVAPORATOR
- (F) ENCHILL MICROPROCESSOR CONTROLS

**DIMENSIONS (INCHES)**

MODEL	LENGTH	WIDTH	HEIGHT
ECA-65-G	120	82	72
ECA-70-G	130	88	72
ECA-100-G	145	92	72
ECA-130-G	145	98	72

**CUSTOMER POINTS OF CONNECTION**

- (1) CHILLED WATER INLET
- (2) CHILLED WATER OUTLET
- (3) REFRIGERANT SUPPLY TO AIR COOLED CONDENSER
- (4) REFRIGERANT RETURN FROM AIR COOLED CONDENSER
- (5) ENGINE EXHAUST
- (6) RADIATOR SUPPLY
- (7) RADIATOR RETURN
- (8) NATURAL GAS INLET
- (9) LUBE OIL MAKE-UP
- (10) MOUNTING HOLES

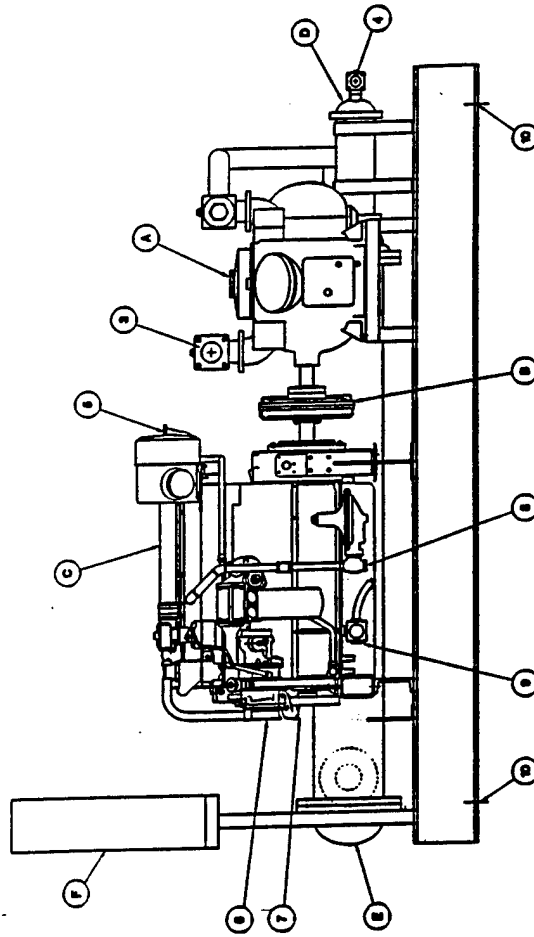

<p><b>ENGINE DRIVEN CHILLER</b></p>	<p><b>A - 2</b></p>	<p>DATE: 02/04/95 REV: 1</p>												
<p><b>ENGINE SKID ASSEMBLY LEFT SIDE ELEVATION</b></p>		<p>SCALE: 1/8" = 1'-0"</p>												
<p><b>ENCHILL</b> by MKW ENGINE DRIVEN CHILLERS 785 GRAND AVENUE, SUITE 206 CARLEBAD, CA 95008</p>		<p><b>PL CHAMP-AR</b></p>												
<p><b>PLF</b> POWER LINE FLEX CONCRETE ANCHORS</p>		<p>DATE: 02/04/95 REV: 1</p>												
<p>REVISIONS</p> <table border="1" style="width: 100%; border-collapse: collapse;"> <thead> <tr> <th>NO.</th> <th>DATE</th> <th>DESCRIPTION</th> </tr> </thead> <tbody> <tr> <td> </td> <td> </td> <td> </td> </tr> <tr> <td> </td> <td> </td> <td> </td> </tr> <tr> <td> </td> <td> </td> <td> </td> </tr> </tbody> </table>		NO.	DATE	DESCRIPTION										<p>DATE: 02/04/95 REV: 1</p>
NO.	DATE	DESCRIPTION												

**EQUIPMENT LIST**

- (A) RECIPROCATING COMPRESSOR
- (B) TORSIONAL COUPLING
- (C) INDUSTRIAL GAS ENGINE
- (D) REFRIGERANT DRYER
- (E) EVAPORATOR
- (F) ENCHILL MICROPROCESSOR CONTROLS

**DIMENSIONS (INCHES)**

MODEL	LENGTH	WIDTH	HEIGHT
ECA-75-C	120	82	72
ECA-75-E	130	88	72
ECA-100-C	145	88	72
ECA-130-C	160	98	72

**CUSTOMER POINTS OF CONNECTION**

- (1) CHILLED WATER INLET
- (2) CHILLED WATER OUTLET
- (3) REFRIGERANT SUPPLY TO AIR COOLED CONDENSER
- (4) REFRIGERANT RETURN FROM AIR COOLED CONDENSER
- (5) ENGINE EXHAUST
- (6) RADIATOR SUPPLY
- (7) RADIATOR RETURN
- (8) NATURAL GAS INLET
- (9) LUBE OIL MAKE-UP
- (10) MOUNTING HOLES

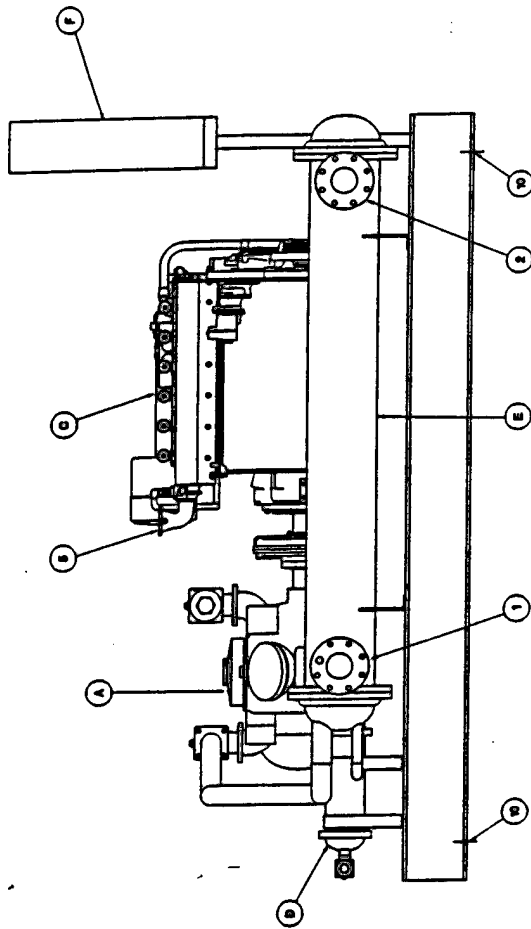

	<p><b>ENCHILL</b> by MKW ENGINE DRIVEN CHILLERS 785 GRAND AVENUE, SUITE 206 CARLSBAD, CA 92008</p>		<p><b>A - 3</b></p>
MODEL: _____ SERIAL: _____ DATE: _____ SIZE: _____ CODE: _____	SHEET: 1 OF 1 DATE: 8/27/91 SIZE: 1/2" X 1/2"	PROJECT: _____ DRAWING NO: _____ REVISIONS: _____	SCALE: _____ DATE: _____