

0521

REPORT DOCUMENTATION PAGE

Public reporting burden for this collection of information is estimated to average 1 hour per response, including gathering and maintaining the data needed, and completing and reviewing the collection of information. Send collection of information, including suggestions for reducing this burden, to Washington Headquarters Services, Directorate for Information Operations and Reports, 1215 Jefferson Davis Highway, Suite 1204, Arlington, VA 22202-4302, and to the Office of Management and Budget, Paperwork Reduction Project (0704-0188).

RES.
THIS
FORM

1. AGENCY USE ONLY (Leave blank)		2. REPORT DATE September 1; 1997		3. REPORT TYPE AND DATES COVERED Final - 9/1/96/96 to 8/31/97	
4. TITLE AND SUBTITLE High Temperature Sensors and Arrays for Turbomachines				5. FUNDING NUMBERS F49620-95-C-0041	
6. AUTHOR(S) Lawrence W. Langley					
7. PERFORMING ORGANIZATION NAME(S) AND ADDRESS(ES) Vatell Corporation P.O. Box 66 Christiansburg, VA 24073				8. PERFORMING ORGANIZATION REPORT NUMBER	
9. SPONSORING/MONITORING AGENCY NAME(S) AND ADDRESS(ES) Air Force Office of Scientific Research Bolling AFB, DC 20332-0001				10. SPONSORING/MONITORING AGENCY REPORT NUMBER NA	
11. SUPPLEMENTARY NOTES					
12a. DISTRIBUTION/AVAILABILITY STATEMENT Approved for public release: distribution is unlimited				12b. DISTRIBUTION CODE 19971021 180	
13. ABSTRACT (Maximum 200 words) The objective of this program was to create an apparatus and method for laser chemical vapor deposition (LCVD) of sensors in vacuum under control of a multi-axis positioning system. The system will be used to deposit sensors directly on the curved surfaces of turbine blades, which are insulated beforehand with a sputtered layer of alumina, 20 to 40 microns thick. This system embodies several departures from conventional LCVD. A continuous laser is employed instead of a pulsed laser, to improve the consistency and rate of deposition. The evaporation chamber is inside the vacuum chamber and closely coupled to the nozzle which floods the laser focal point. The entire vapor path is heated, with the objective of improving the speed and efficiency of vapor conversion to deposited metal. Unconverted vapor is scavenged by a carrier flow of inert gas before it can enter the main chamber.					
14. SUBJECT TERMS Laser Chemical Vapor Deposition Sensor				15. NUMBER OF PAGES 14	
				16. PRICE CODE	
17. SECURITY CLASSIFICATION OF REPORT UNCLASSIFIED	18. SECURITY CLASSIFICATION OF THIS PAGE UNCLASSIFIED	19. SECURITY CLASSIFICATION OF ABSTRACT UNCLASSIFIED	20. LIMITATION OF ABSTRACT none		

INFO QUALITY INSPECTED 4

Third Annual Progress Report

September 1, 1997

for the period 1 September, 1996 through 31 August, 1997

Contract F49620-95-C-0041

**High Temperature Sensors and Arrays
for Turbomachines**

for

Air Force Office of Scientific Research
Bolling AFB, DC 20332-0001

by

Vatell Corporation
P.O. Box 66
Christiansburg, VA 24073
(540) 961-2001 Fax (540) 953-3010
e-mail vatell@bev.net
home page <http://www.G3.net/vatell/>

Objective:

The objective of this program was to create an apparatus and method for laser chemical vapor deposition (LCVD) of sensors in vacuum under control of a multi-axis positioning system. The system will be used to deposit sensors directly on the curved surfaces of turbine blades, which are insulated beforehand with a sputtered layer of alumina, 20 to 40 microns thick.

Introduction:

Laser chemical vapor deposition is an established process for depositing fine lines of conductive and insulating materials on planar substrates. The only known commercial application is by Micrion, Inc, for the repair of flat panel displays¹. Research by others²⁻¹⁰ has shown that many metals and insulating materials can be deposited on substrates by LCVD, using a variety of organo-metallic precursor gas mixtures, and continuous or pulsed lasers.

During an earlier Phase I project simple line patterns of platinum metal were deposited on coupons of refractory metals which had been insulated with a thin layer of alumina. Deposition was achieved using a pulsed laser at surface speeds of 200 microns per second. The resulting lines were electrically conductive from end to end and electrically insulated from the base metal, demonstrating that the LCVD process produced continuous conductors on the surface without breaking through the alumina coating. Ohmic connections were achieved at line crossings. The system used in this demonstration was the Micrion, Inc. unit.

Summary of Progress:

During the Phase II project a system was constructed for pyrolytic LCVD of sensors on complex curved objects. Figure 1 is a partially sectional drawing of this system. The system consists of:

- (a) a vacuum chamber 1 and framework 2 supporting two linear and two rotary stages 3, 4, 5 and 6 which position the object that is to receive a sensor;
- (b) a fifth axis linear stage 7 supporting an evaporation chamber 8 and laser optics 9 for locally flooding the object's surface with an organo-metallic vapor while focusing the beam of a laser 10 on it;
- (c) a vacuum pump, gages, pressure and flow controls for an inert carrier gas; and
- (d) computer hardware and software for coordinating operation of the laser, the five axes of motion, the vacuum pump, pressure and flow controls.

This system embodies several departures from conventional LCVD. A continuous laser is employed instead of a pulsed laser, to improve the consistency and rate of deposition. The evaporation chamber is inside the vacuum chamber and closely coupled to the nozzle which floods the laser focal point. The entire vapor path is heated, with the objective of improving the speed and efficiency of vapor conversion to deposited metal. Unconverted vapor is scavenged by a carrier flow of inert gas before it can enter the main chamber.

The completed system is shown in figures #2-7.

Figure 2 shows the vacuum chamber mounted on the system base, and the computer operator station. Vacuum pumps, pressure and flow controls are mounted on a cart behind the system base.

Figure 3 is a view from the opposite direction, showing the same components, with vacuum pumps, pressure and flow controls in the foreground, to the left.

In Figure 4 the system is shown with the vacuum chamber lifted, revealing the yoke which supports the four stacked numerically controlled stages, and feed-throughs on the base for drive and control signals. To the right of center is the evaporator and laser objective assembly, mounted on the vertical stage.

Figure 5 is a closeup of the evaporator and laser focal assembly. The part to be instrumented with a sensor is mounted on the second rotary axis, shown to the left. The laser beam is focused at a spot on the bottom of the part. Precursor - carrier gas mixture flows from the evaporator out of the inner nozzle, flooding the laser focal point. Coordination of drive signals to the three linear and two rotary stages maintains spacing of the nozzle from the part, while always holding the part surface normal to the beam.

Figure 6 shows how the two linear and two rotary stages are mounted on the yoke inside the vacuum chamber.

Figure 7 illustrates the temperature control screen display of the Labview software which coordinates and controls motions, temperatures, pressures, and flows of the system, all in real time.

Functional tests of LCVD under two axis control are in progress. Depositions of line patterns in platinum and other metals on square coupons of Hastelloy-X, Waspalloy and Stellite will define system deposition rates, line widths and other performance parameters. Sensors initially produced will be platinum resistance temperature sensors and nickel strain gages, followed by thermocouples and heat flux gages. These sensors will be performance tested to establish the temperature limits of their adhesion, thermal characteristics and accuracy. The knowledge of system operation

gained from depositions on flat coupons will then be applied to depositions on curved surfaces such as cylinders, spheres and airfoils.

Detailed Description of Project:

A thorough search of the technical and patent literature on LCVD was carried out. There was a notable lack of references to sensor fabrication. The objective of most reported research was to produce fine conductors for repair of miniature circuits. CRI¹¹ had produced fine fibers of ZnSe by an LCVD process. Micrion, Inc. and CRI were both visited.

Conclusions from the literature search and visits were:

1. a vacuum in the vicinity of 1 torr would be needed;
2. consistent deposition would require extremely fine control of the precursor evaporation temperature and the carrier flow rates;
3. the laser intensity, focal distance and traverse speed would all have to be precisely controlled; and
4. the requirements for system coordination and control would be extremely stringent.

The first order of business in sizing the system was to decide on the maximum dimensions of turbine blades that it would accommodate. Contacts were made with Pratt & Whitney, General Electric and Allison. According to each manufacturer the blades which would be of the greatest interest to instrument were the first stage turbine blades, and these are typically among the smallest in an engine. It was concluded that a working volume of 4" by 2" by 1" would make the system useful for applying sensors to many gas turbine blades

Preliminary discussions with numerical motion control vendors forced the conclusion that it would be difficult, if not impossible, to stack all five stages of motion together with the necessary blade fixturing. The stage supporting all the others would have to be quite massive, and the vacuum chamber would, as a result, be very large. Alternatives for grouping the stages were explored, and it was decided to adopt an arrangement with four stages inside the vacuum chamber and one outside. For convenience in loading, the linear stage on the outside was located below the vacuum chamber, and the bell jar above it. This allowed use of a conventional bell jar crane, which was required because of the weight of the jar.

In order to achieve the objective of 1 micron positioning accuracy, the strains in the apparatus produced by vacuum forces had to be controlled. This was done by

mounting the four stages inside the vacuum chamber on a heavy, stiff yoke, and the fifth stage also on a yoke beneath the vacuum chamber. The attachment points of the two yokes were made coincident, so that compression of the bell jar and bending of the base under vacuum forces would not effect the position of the laser focus on the turbine blade.

LCVD processes are reported in the literature with both continuous and pulsed lasers, over a wide range of power levels. The table below is a summary of those which are reported in enough detail to be useful as references for the design of this system.

TABLE 1

	Harish	Müller	Jerominek	Jerominek
Laser power - watts	4.0	0.02	.40	.40
Power density - kW/cm ²	51	102	10523	105
Spot diameter - microns	100	5.0	2.2	11.0
Material deposited	Cu	Cu	Si	Si

The laser employed by Harish and Prabhakar¹² was a Q-switched Nd:YAG. The one used by Müller¹³ was a 100 kHz Q-switched, frequency doubled (532 nm) Nd:YAG. Jerominek¹⁴ used a continuous argon-ion type for his research.

The information in these reports did not clearly indicate a direction for the design of this system. A finite element analysis of the deposition process was attempted, but there were too many unknowns for the result to be useful. For example, there was no data available on the absorptivity of a thin film of alumina on a highly polished refractory metal alloy, taking temperature and wavelength into account. This information would be needed to predict the amount of energy initially absorbed from the laser beam. As soon as heating and deposition occur, the emissivity will change to that of a metallic thin film with changing surface roughness, and its absorptivity as a function of temperature and wavelength are also unknown. The dynamics of the LCVD process are too complex for analysis. The only way to understand them is by experiment.

It is believed that previous investigators did not choose a laser by any analytical process, but had access to an existing laser and used it, rather than buying one especially for their project.

Other considerations involved in the choice of a laser were the diffraction limitation to spot size, controllability, cost, reliability, stability and life. Diode-pumped infrared lasers met all the criteria. The final choice was a Spectra-Physics T10-V-106C-1-CW

laser, which produces a maximum continuous power of 2.95 watts at 1064 nm (infrared). The spot diameter of this laser is limited by diffraction to about 10 microns. At this diameter the maximum and minimum power densities of this laser are 3760 and 127 kw/cm² (assuming no losses in the optical path). If the lowest controlled power level for this laser turns out to be too high, it can be reduced by filtering. Thus it is possible with this laser to reach all the expected intensities for LCVD.

The only problem found with the Spectra-Physics laser was that its turn-on and turn-off times are too long for direct control of line writing. Much more rapid and direct control can be achieved by simply moving the vertical stage to de-focus the laser. This can be done in milliseconds.

Few details were available in the references regarding the physical arrangement of the evaporator and passages for precursor gas transport to the laser focal point. It had been observed during visits to Micrion, Inc. in Boston, MA and CRI in Evanston, IL, that their evaporators were not closely coupled to the point of deposition, but were connected to it by long plastic tubes. Clearly, the temperatures of these tubes could not be not accurately controlled. Much of the evaporated precursor would be likely to deposit out as it passed through them. Also, the temperature of the precursor gas mixture was not accurately controlled at the laser focal point.

It was decided that for sensor LCVD the system would have to control the composition and temperature of the precursor gas mixture much more closely. To do this, the tubes carrying the gas were shortened to a minimum by mounting the evaporator immediately adjacent to the laser focussing assembly on the external linear stage, but within the vacuum chamber. Locating it within the vacuum had the additional benefit of improving its thermal isolation, so that less power would be required for heating and the chamber temperature could be better controlled. Also, the temperature of the orifice surrounding the laser focal point would be controlled. Figures 1 and 5 show the final arrangement.

Another consequence of mounting the evaporator on the external linear stage was that all the heater and thermocouple wires and the gas supply tubes would have to be flexible, allowing the stage to move through more than 1" of travel without crimping them. This was achieved by dressing them in a short loop.

There was not enough room in the cabinet to mount the laser vertically, so a mirror was added to turn the beam 90° from the horizontal. This mirror was mounted on an alignment fixture, to allow final pointing of the beam after assembly of the system.

Mechanical, electrical, optical and thermal components of the system were designed and fabricated. Temperature, pressure and flow control instruments were selected and purchased, as well as the laser, linear and rotary stages, vacuum chamber,

vacuum pump and many other hardware items. Mechanical components which might produce vibration and interfere with positioning accuracy during system operation were mounted on a separate cart to isolate them. All parts of the system were assembled, wired and piped together and individually tested. To capture the minute amount of organo-metallic gas which would be discharged by the system in operation, a cold trap was added to the vacuum pumping system.

To produce sensors on turbine blades, the mechanical motions of this system have to be coordinated with the flow and temperature controls. The only practical way to do this is to have a supervisory computer which communicates with the various controllers, scheduling and commanding all system functions. A PC was selected, and Labview¹ software was written. Many difficulties were encountered in establishing communications between the PC and the variety of instruments it controls, because they came from different manufacturers. All these difficulties were solved, and the entire system was made to function as intended.

Conclusion:

A system for laser chemical vapor deposition of sensors on turbine blades and other objects with complex curvature has been designed and assembled. All functions have been individually tested, and the combined, coordinated function has been demonstrated. The next phase of this project is to use the system to perform depositions and test the resulting sensors.

This work was sponsored by the Air Force Office of Scientific research, USAF, under grant number F49620-95-C-0041. The views and conclusions contained herein are those of the author and should not be interpreted as necessarily representing the official policies or endorsements, either expressed or implied, of the Air Force Office of Scientific Research or the U.S. Government.

References:

1. "Production Repairs of Flat Panel Arrays Using Laser Photochemistry", Casey, J.D., Communale, R. and Libby, C., SEMI Kansai Technical Proceedings, pp. 89-92, 1991
2. "Laser-Induced Decomposition of Organo-Metallic Compounds", Gerassimov, R.B., Metev, S.M. and Savtchenk, S.K., Applied Physics, vol. B28, p.266, 1982
3. "Laser Writing of Copper Lines from Metalorganic Films", Gupta, A. and

¹Labview is a trademark of National Instruments

Jagannathan, R., Applied Physics Letters, vol. 51, pp. 2254-2256, 1987

4. "Deposition of Micron-Size Nickel Lines by Argon-ion Laser-Assisted Decomposition of Nickel Tetracarbonyl", Boughaba, S. and Auvert, G., Applied Surface Science, Vol 69, 1-4, May 2 1993 Proceedings of Symposium B on Laser, Lamp and Synchrotron Assisted Materials Surface Processing of the 1992 E-MRS Spring Conference, Strasbourg, France, Jun 2-5, 1992, pp. 79-86
5. "Photo-induced chemical vapour deposition of silicon oxide thin films", Gonzalez, P., Fernandez, D., Pou, J., Garcia, E., Serra, J., Leon, B. and Perez-Amor, M., Thin Solid Films, vol. 218 no. 1-2, Oct 15, 1992, pp 170-181
6. "Diode Laser Induced Chemical Vapor Deposition of W on TiN from WF_6 and SiH_4 ", Desjardins, P., Izquierdo, R. and Meunier, M., Journal of Applied Physics, vol 73, no. 10, pp 5216-5222, May 15, 1993
7. "Growth Kinetics of Micron-Size Nickel Lines Produced by Laser-assisted Decomposition of Nickel Tetracarbonyl", Boughaba, S. and Auvert, G., Journal of Applied Physics, vol. 73, no.12, pp 8590-8601, Jun 15, 1993
8. "Continuous-wave Laser-assisted fabrication of Microstructures in Silicon Microelectronics", Auvert, G., SPIE vol. 2045, pp. 72-83, Jun 1994
9. "Photo-CVD of Dielectric Materials by Pseudo-continuous Excimer Sources", Bergonzo, P., Kogelschatz, U. and Boyd, I.W., SPIE, vol. 2045, pp. 174-181, Jun 1994
10. "Three-Dimensional Laser Direct Writing: Applications to Multichip Modules", Nassupis, N., Mathews, R.H., Palmacci, S.T. and Ehrlich, D.J., Journal of Vacuum Science and Technology B, 12(6), pp.1-6, Nov/Dec 1994
11. "Production of Microstructures by Laser Pyrolysis", D. Bauerle, Materials Research Society Symposium Proceedings, Vol. 17, 19-28 (1983)
12. "A Novel Laser Direct Write Technique for Fabrication of Thin Film MIC's", Harish, C.M., Kumar, V. and Prabhakar, A., IEEE Transactions on Semiconductor Manufacturing, Vol. 6, No. 3, August 1993
13. "Photothermal Formation of Copper Conductors on Multichip Module Substrates Using a Nd:YAG Laser", Müller, H. G., IEEE Transactions on Components, Hybrids, and Manufacturing Technology, Vol. 16, No. 5, August 1993
14. "Laser-Assisted Deposition and Etching of Silicon for Fabrication of Refractive and Diffractive Optical Elements", Jerominek, H. and Pan, J., SPIE, Vol. 2045

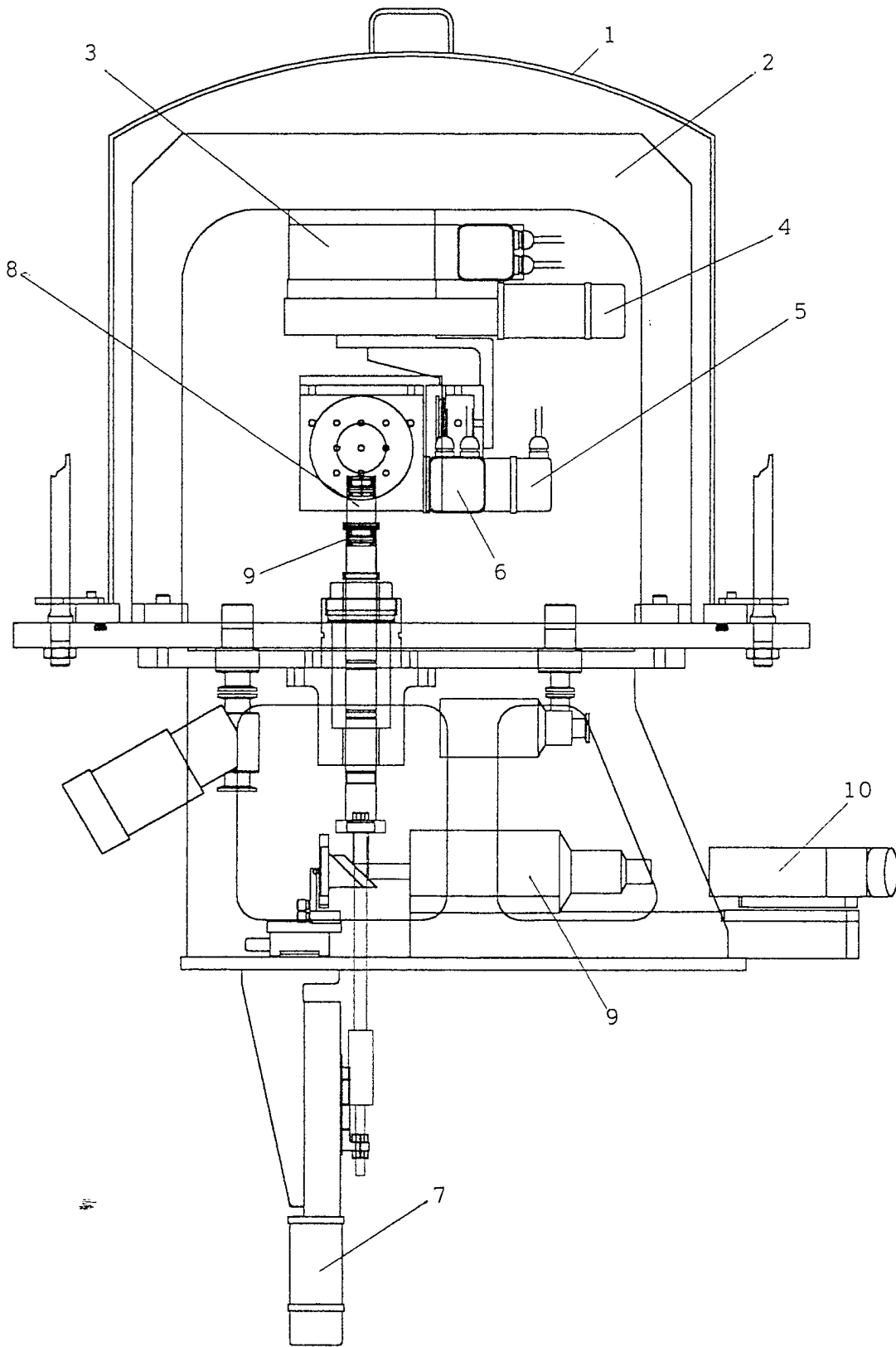

Figure 1

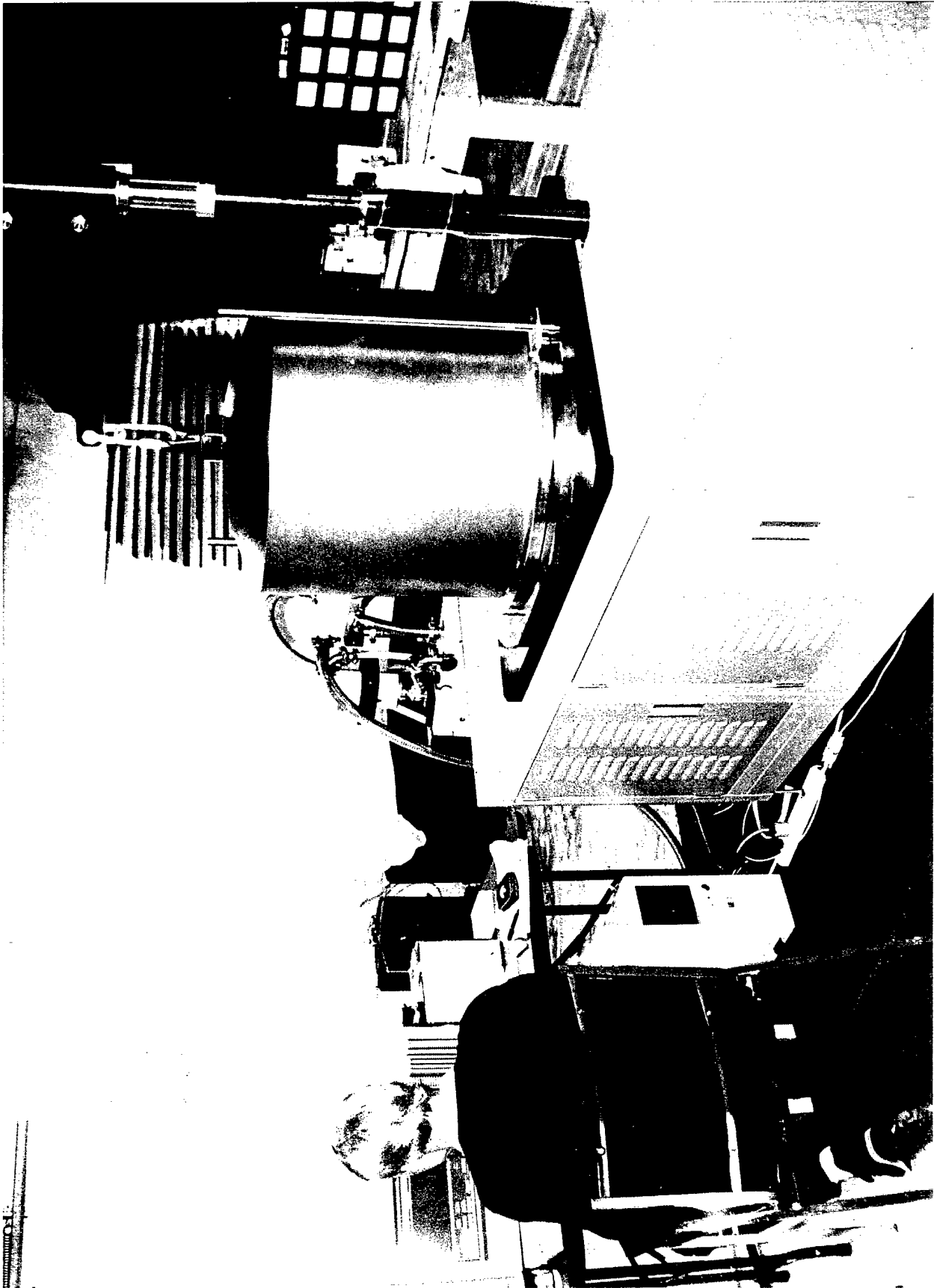

Figure 2

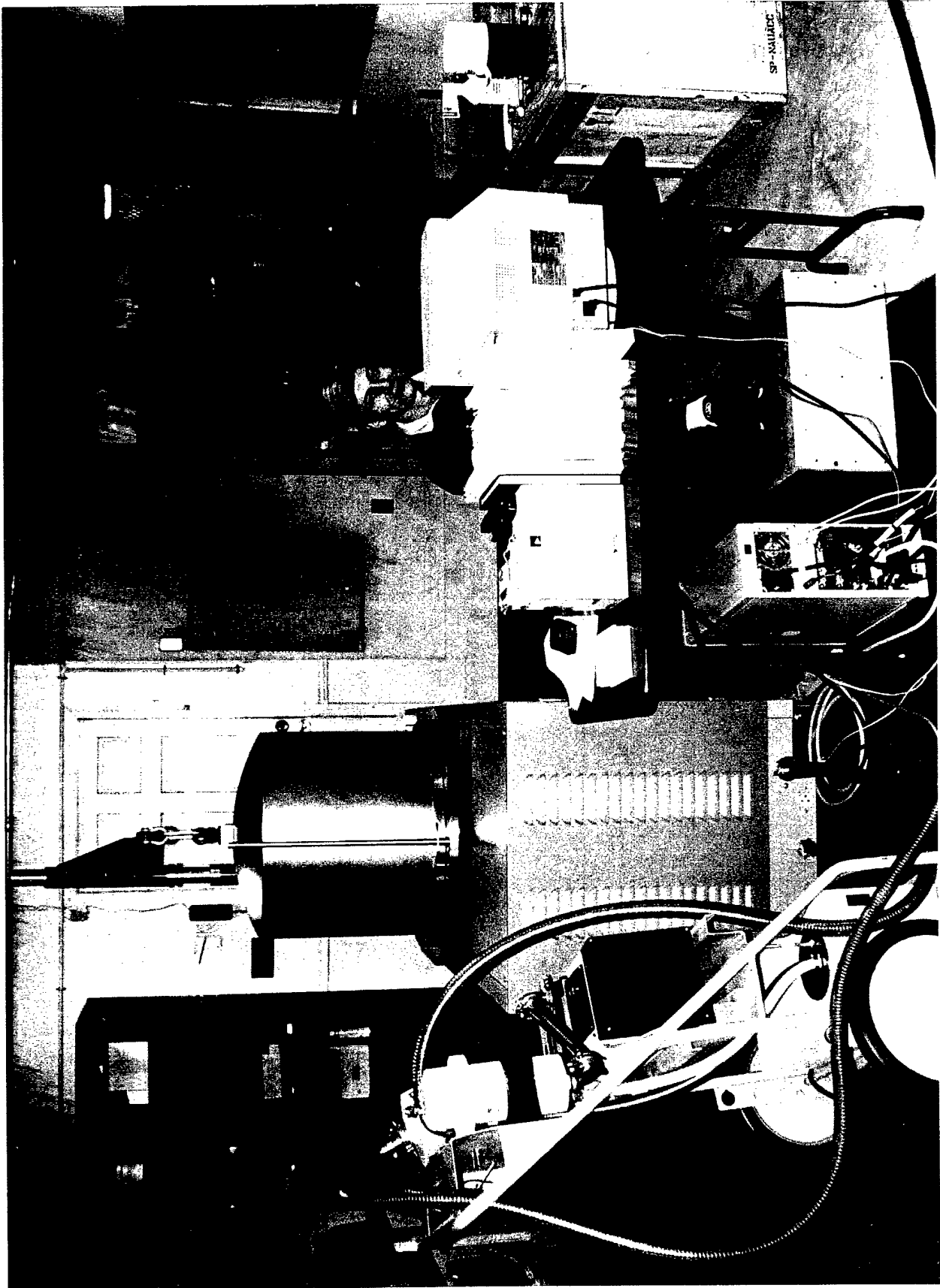

Figure 3

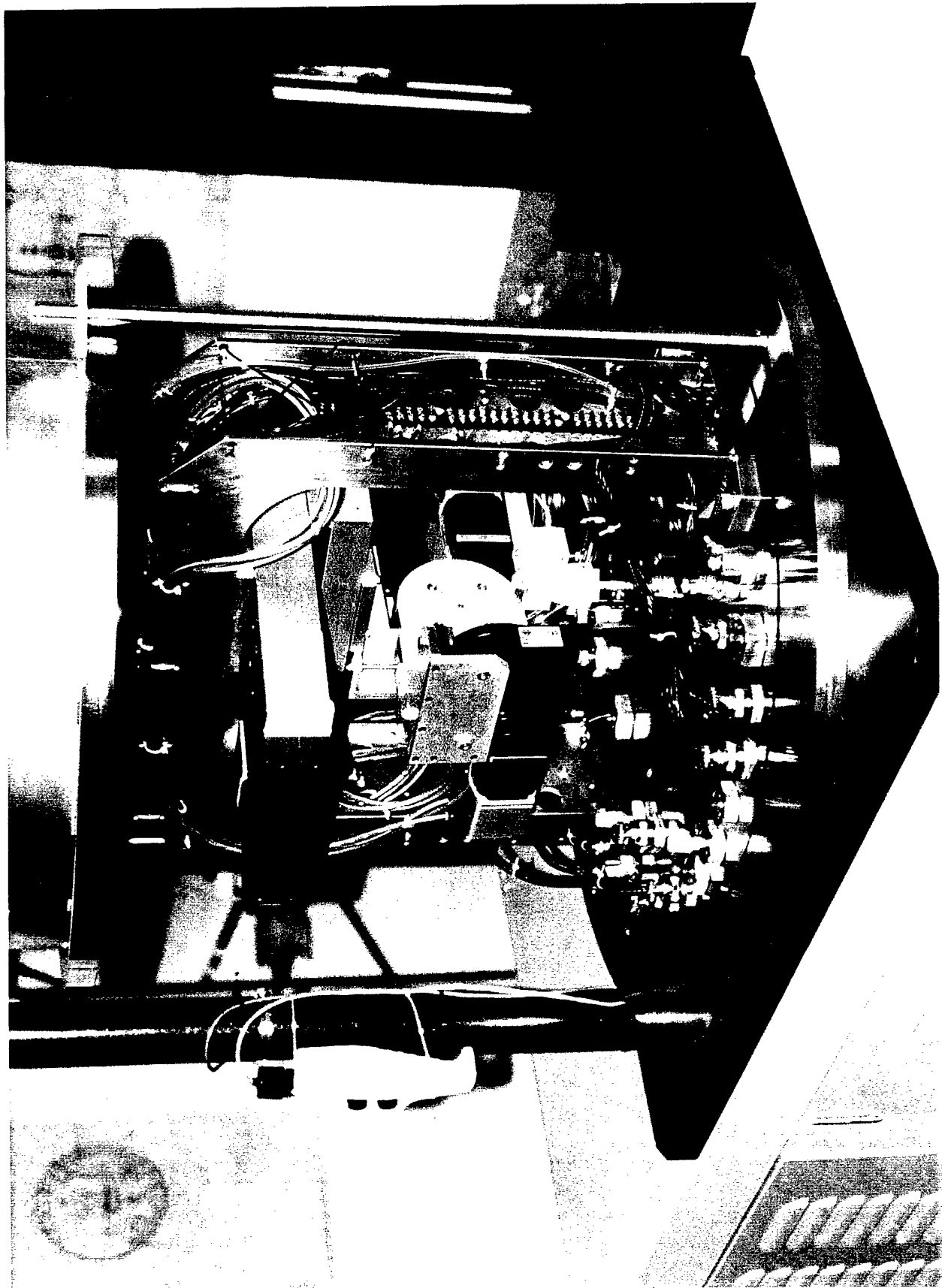

Figure 4
11

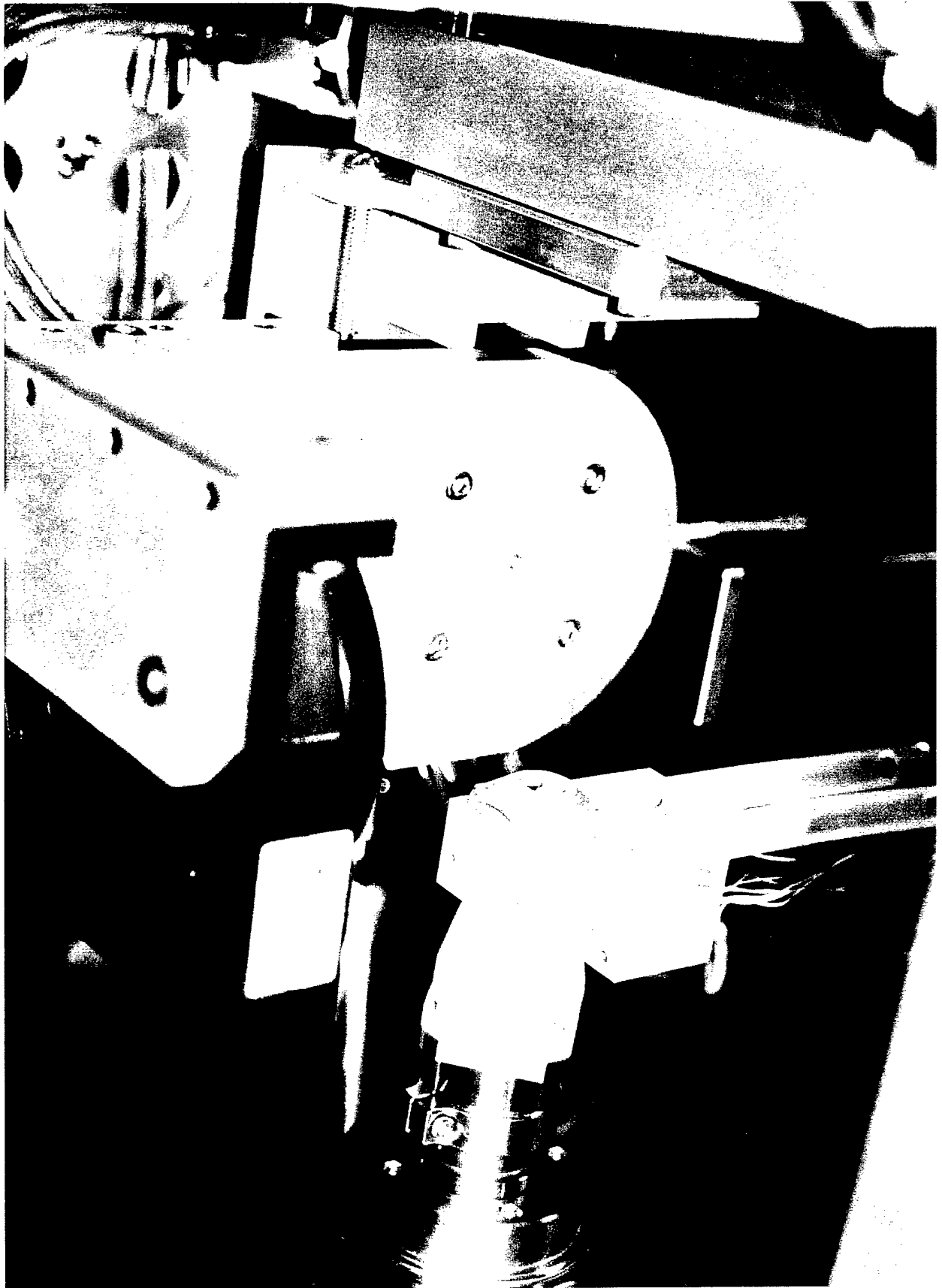

Figure 5

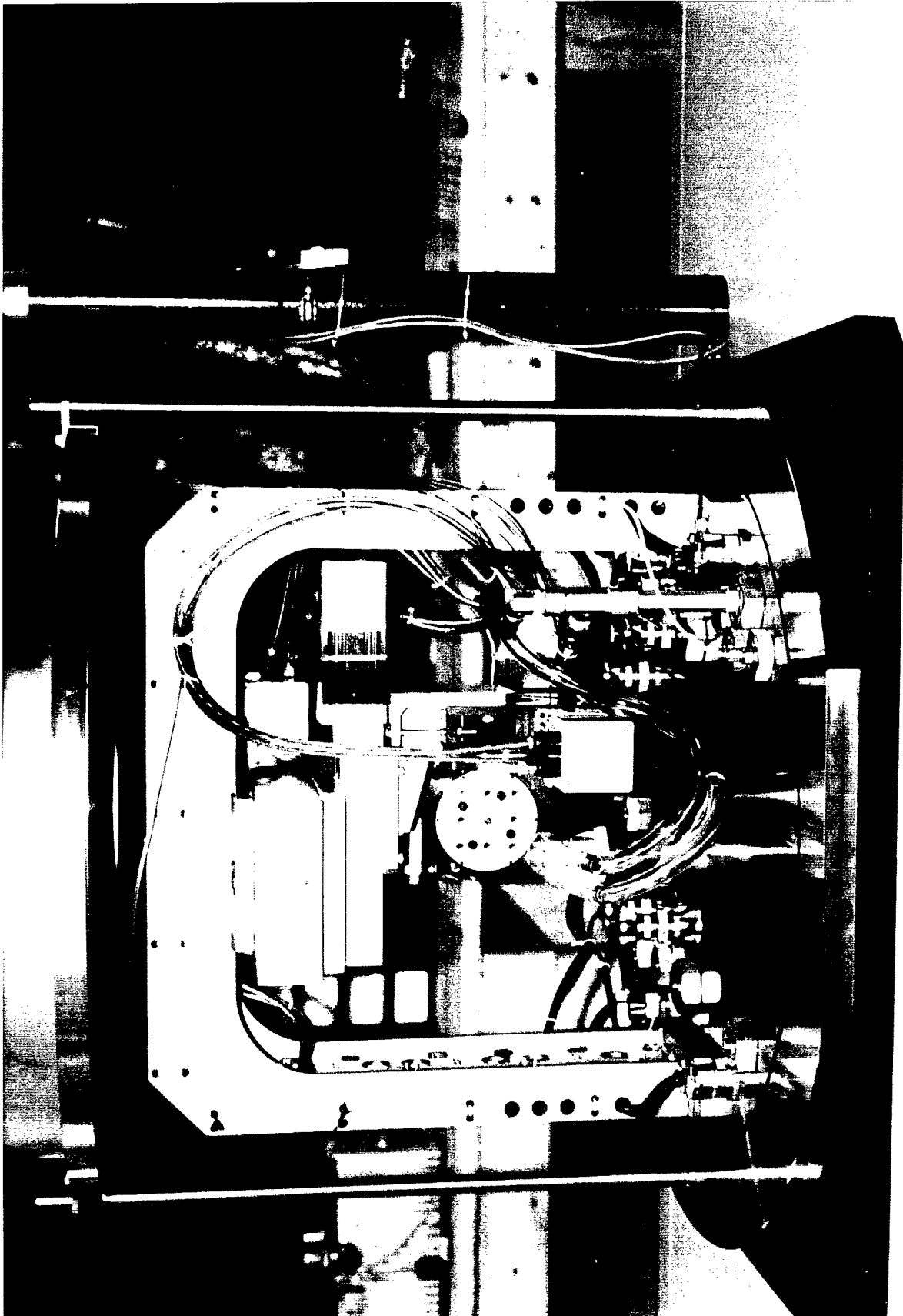

Figure 6

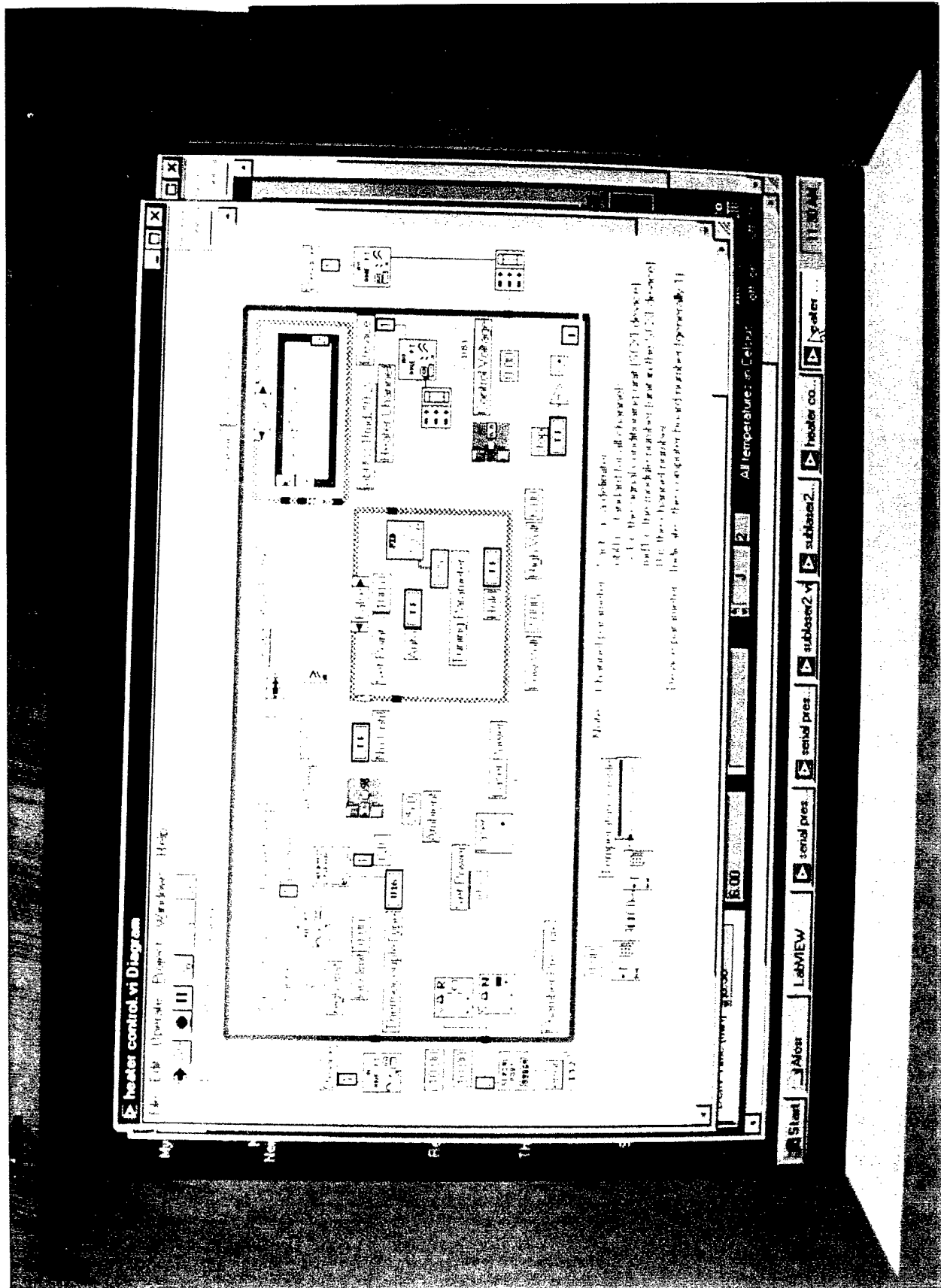

Figure 7