

aw

.....MAL SIGNATURE TARGETS FOR LIVE FIRE TRAINING WITH THERMAL SIGHTS

By Albert Marshall
Dr. Herbert Towle
Bon Shaw
George Siragusa

TECHNICAL
LIBRARY



19971017 299

DISTRIBUTION STATEMENT B
Approved for public release
Distribution Unlimited

FINAL REPORT VOLUME I

DTIC QUALITY INSPECTED 3

PREPARED FOR
U.S. ARMY PROJECT MANAGER FOR TRAINING DEVICES
NAVAL TRAINING EQUIPMENT CENTER (NTEC)
ORLANDO, FLORIDA 32813

BY
RESEARCH AND TECHNOLOGY DEPARTMENT NTEC

●
DECEMBER 1977

DISCLAIMER

The contents of this publication are not to be construed as an official Department of the Army position, unless so designated by other authorized documents.

Citation of manufacturer's or trade names does not institute an official endorsement or approval of the use thereof.

Destroy this report when no longer needed. Do not return it to the originator.

UNCLASSIFIED

SECURITY CLASSIFICATION OF THIS PAGE (When Data Entered)

REPORT DOCUMENTATION PAGE		READ INSTRUCTIONS BEFORE COMPLETING FORM
1. REPORT NUMBER PM TRADE-SE-78-0001	2. GOVT ACCESSION NO.	3. RECIPIENT'S CATALOG NUMBER
4. TITLE (and Subtitle) Thermal Signature Targets for Live Fire Training with Thermal Sights - Final Report Vol 1		5. TYPE OF REPORT & PERIOD COVERED Final Report Vol 1
		6. PERFORMING ORG. REPORT NUMBER PM TRADE-SE-78-0001
7. AUTHOR(s) Albert Marshall, Dr. Herbert Towle, Bon Shaw and George Siragusa		8. CONTRACT OR GRANT NUMBER(s)
9. PERFORMING ORGANIZATION NAME AND ADDRESS Naval Training Equipment Center Research and Technology Department Orlando, Florida 32813		10. PROGRAM ELEMENT, PROJECT, TASK AREA & WORK UNIT NUMBERS
11. CONTROLLING OFFICE NAME AND ADDRESS Project Manager for Training Devices United States Army Orlando, FL 32813		12. REPORT DATE December 1977
14. MONITORING AGENCY NAME & ADDRESS (if different from Controlling Office)		13. NUMBER OF PAGES 95
		15. SECURITY CLASS. (of this report) UNCLASSIFIED
		15a. DECLASSIFICATION/DOWNGRADING SCHEDULE
16. DISTRIBUTION STATEMENT (of this Report) Approved for public release; distribution unlimited.		
17. DISTRIBUTION STATEMENT (of the abstract entered in Block 20, if different from Report)		
18. SUPPLEMENTARY NOTES		
19. KEY WORDS (Continue on reverse side if necessary and identify by block number) Thermal Targets Infantry Targets Far Infrared Live Fire Targets Thermal Sights IR Targets Tank Targets Simulator		
20. ABSTRACT (Continue on reverse side if necessary and identify by block number) Volume 1 of this report describes research, development, construction and testing of thermal signature targets. These targets are designed to produce effective signatures in the 8 to 14um region. Volume 2 contains classified data of thermal target pictures taken through the thermal sight.		

DD FORM 1 JAN 73 1473

EDITION OF 1 NOV 65 IS OBSOLETE
S/N 0102

UNCLASSIFIED

SECURITY CLASSIFICATION OF THIS PAGE (When Data Entered)

SECURITY CLASSIFICATION OF THIS PAGE(When Data Entered)

SECURITY CLASSIFICATION OF THIS PAGE(When Data Entered)

PREFACE

The authors wish to thank David Holliday of the U.S. Army Armor Engineer Board for his cooperation in arranging the live-fire testing of the thermal targets at Ft. Knox, Kentucky.

The authors also wish to thank Joel Russeau, an FTU student, who aided in the design and construction of the prototype targets during summer employment.

Classified material taken through the thermal sight is contained in Volume 2 of this report of the same title.

TABLE OF CONTENTS

Preface	i
I. Introduction	I-1
II. Approach	II-1
III. Thermal Signature Target Design.	III-1
A. General.	III-1
B. Design Analysis.	III-2
C. Description of the Target Materials.	III-8
D. Design Examples.	III-10
E. Scaled Models.	III-17
F. Target Temperature Control	III-20
IV. Construction of Thermal Signature Targets.	IV-1
A. Thermal Signature Targets (Temsheet) T-62 Full-Scale Frontal View Target Construction	IV-1
B. Thermal Signature Targets (Temsheet) T-62 Full-Scale Flank View Target Construction	IV-10
C. Thermal Signature Man Target Construction.	IV-30
V. Test Results	V-1
A. Laboratory Testing	V-1
B. Field Testing.	V-6
VI. Conclusions.	VI-1
References	R-1
Appendix	
A Program to Calculate Thermal Target Performance Using the HP-67 Calculator	A-1

DMIC QUALITY INSPECTED

ILLUSTRATIONS

III-1	Calculated Temperature Rises on the Front and Back Surface of a Target Versus Power Input.	III-4
III-2	Calculated Temperature Rises Versus Power Input with Wind Losses Considered	III-5
III-3	Effective Wheel Resistance.	III-15
III-4	Temperatures Both Calculated and Measured on a Wheel (Paint Target).	III-18
III-5	Temperatures Both Calculated and Measured on a Wheel (Tensheet).	III-19
IV-1	Frontal Target Turret Section (Front Side).	IV-2
IV-2	Frontal Target Right Section (Front Side)	IV-3
IV-3	Frontal Target Left Section (Front Side).	IV-4
IV-4	Frontal Target Frame Layout (Rear Side)	IV-5
IV-5	Frontal Target Frame Member Specifications (Rear Side).	IV-6
IV-6	Frontal Target Piece Assembly (Front Side).	IV-7
IV-7	Staple Locations in Copper Electrode.	IV-8
IV-8	Copper Electrode Folded to Fit Curved Surface	IV-9
IV-9	Frontal Target Screw Locations (Front Side)	IV-11
IV-10	Frontal Target Aluminum Conductor Placement (Rear Side)	IV-12
IV-11	Frontal Target Negative Aluminum Conductor (Rear Side).	IV-13
IV-12	Frontal Target Positive Aluminum Conductor (Rear Side).	IV-14
IV-13	Frontal Target Battery Hookup (Rear Side)	IV-15
IV-14	Flank Target Piece Assembly (Front Side).	IV-16
IV-15	Flank Target Rear Section (Front Side).	IV-17
IV-16	Flank Target Middle Section (Front Side).	IV-18
IV-17	Flank Target Front Section (Front Side)	IV-19
IV-18	Flank Target Turret (Front Side).	IV-20

IV-19	Flank Target Engine Box (Front Side)	IV-21
IV-20	Wheel Hub Construction.	IV-22
IV-21	Folding of Copper Electrode to Form a Wheel Rim	IV-22
IV-22	Stapling of Copper Electrode.	IV-23
IV-23	Flank Target Frame Specifications (Rear Side)	IV-25
IV-24	Flank Target Screw Locations (Front Side)	IV-26
IV-25	Flank Target Negative Aluminum Conductor (Rear Side).	IV-27
IV-26	Flank Target Positive Aluminum Conductor (Rear Side).	IV-28
IV-27	Flank Target Aluminum Conductor Placement (Rear Side)	IV-29
IV-28	Flank Target Battery Hookup (Rear Side)	IV-32
IV-29	Man Target Center Conductor (Front Side).	IV-34
IV-30	Man Target Center and Edge Conductors (Front Side).	IV-35
IV-31	Man Target Battery Hookup (Rear Side)	IV-36
V-1	Temperature Measurement on Frontal Temsheet Target.	V-2
V-2	Temperature Measurement on Frontal Paint Target	V-3
V-3	Temperature Measurement on Flank Temsheet Target.	V-4
V-4	Temperature Measurement on Flank Paint Target	V-5
V-5	Flank Target (0 mph wind)	V-9
V-6	Flank Target (17 mph wind).	V-9
V-7	Flank Target (25 mph wind).	V-9
V-8	Frontal Target (0 mph wind)	V-10
V-9	Frontal Target (15 mph wind).	V-10
V-10	Frontal Target (25 mph wind).	V-10
V-11	Full-Scale Targets.	V-12
V-12	Frontal Target (Full Scale)	V-13
V-13	Frontal and Flank Target (Full Scale)	V-13
V-14	Man and Man Target.	V-13

SECTION I

INTRODUCTION

Thermal sights are scheduled for issue beginning in May 1978. Thermal signature targets for live-fire exercises, however, are not scheduled for issue until a later date as part of the Armor Remote Target System (ARETS). Interim thermal signature targets are, therefore, needed for training exercises until ARETS targets become available.

This report describes research, development, construction and testing of effective interim thermal signature targets. These targets have been successfully tested in live-fire training exercises by tank gunners using thermal sights. Both Armor and Infantry thermal targets were developed. The thermal targets are rugged, low cost, and can be locally manufactured with lightweight, low-cost materials. Thermal signatures produced by targets have been demonstrated during field test at Ft. Knox to closely resemble the actual target's signature.

Analysis, design, breadboard design and testing results are described. Methods of target construction are also included.

Classified material taken through the thermal sight is contained in Volume 2 of this report of the same title.

SECTION II

APPROACH

The research and development approach was divided into four phases.

- PHASE I
 - . Study methods of thermal target signature generation
 - . Study thermal sights
 - . Study target materials
 - . Recommend thermal target configuration
- PHASE II
 - . Breadboard design and fabrication
- PHASE III
 - . Field test of breadboard
- PHASE IV
 - . Final report

Four basic approaches to target configurations were identified and studied.

- . Direct heating of selected target areas using electrical heating methods
- . Heating a target panel by rear illumination
- . Heating a target panel by front illumination
- . Reflection of passive, sky radiation

The results achievable by these various methods were compared using the following set of comparison factors.

1. Cost
2. Simplicity
3. Mobility
4. Ease of Fabrication
5. Maintenance
6. Suitability to Automation
7. Adaptation to 3-D Targets
8. Supporting Equipment Needed
9. Manageability
10. Adaptation to Other than Plywood
11. Fidelity of Effect
12. Dependence on Environment

13. Weatherability
14. Safety
15. Power Consumption
16. Efficiency of Energy Use
17. Power Utilization

Direct heating of selected target areas using electrical methods received the highest overall rating. This method was selected by PM TRADE. The passive sky reflection method received the second highest score.

This study was performed jointly by NAVTRAEQUIPCEN and the Environmental Research Institute of Michigan, ERIM, formerly Willow Run Laboratories, The University of Michigan. Details of this study are contained in reference 1, the ERIM report.

After completion of this study, NAVTRAEQUIPCEN designed, fabricated and tested thermal targets using the direct heating approach. Subsequent sections of the report describe this effort.

SECTION III

THERMAL SIGNATURE TARGET DESIGN

A. GENERAL

A thermal sight views its surroundings in the far-infrared, 8 to 14 micron range. The sight responds to electromagnetic, EM, radiation of wavelengths between 8×10^{-6} meters and 14×10^{-6} meters. Electromagnetic, EM, radiation is generated by vibration and rotation of atoms and molecules within any material whose temperature is above absolute zero. Objects near room temperature produce EM radiation, most of which is to be found to have wavelengths in the 8 to 14 micron range.

Light, TV, X-rays, and radiation from fissioning uranium all are examples of EM radiation. Their wavelengths, however, are far different; for example, 1 Mev gamma rays have a wavelength of 1.24×10^{-12} m or about 10 million times shorter than the wavelengths to which the thermal sight responds. The longest wavelength of visible light is approximately 0.7 microns or 0.7×10^{-6} meters, nearly 10 times shorter than the infrared region viewed by the thermal sight.

The total amount of radiation emitted by a heated body may be calculated from the Stefan-Boltzmann equation:

$$Q_r = \epsilon A \sigma T^4$$

where, Q_r = radiated power, watts

ϵ = emissivity (unitless)

A = Area, m^2

σ = Stephan-Boltzman constant, 56.697×10^{-9} watts/m² - ($^{\circ}K$)⁴

T = temperature, $^{\circ}K$, ($^{\circ}C + 273.15$). (1)

From equation (1), it is evident that the EM radiation is a strong, 4th degree, function of temperature, T . In fact, it follows that a 1 percent change in temperature T produces a 4 percent change in radiated power. This explains the great sensitivity of the thermal sight to temperature differences of viewed objects.

To effect a temperature increase of a thermal target, power is needed not only to supply the useful EM radiated power but losses as well. These losses are caused by:

- (1) Radiation emitted from surfaces of the target not viewed by the thermal sight.
- (2) Convection from all surfaces.

(3) The heat capacity of the target or its "thermal inertia."

Convection losses occur through temperature increase of the air in contact with the target. This heated air provides essentially no useful radiation. Convection losses increase rapidly with cross wind unless the target surface is protected by a suitable thermal insulating blanket. Cellular plastic packing material is good because it causes little decrease in radiation while providing dead air thermal insulation of the target from the surrounding moving air.

Radiation from surfaces may also be controlled by using high emissivity material, i.e., a black surface. Materials used in the construction of the target are black, with $\epsilon > .9$.

B. DESIGN ANALYSIS

A power balance between input and output can be written as:

$$Q_{in} = Q_{rs} + Q_{rb} + Q_{cs} + Q_{cb} + C \frac{dT}{dt} \quad (2)$$

where,

Q_{in} = Input power, watts

Q_r = Radiated power, watts

Q_c = Convected power, watts

C = Heat capacity, watt-sec/ $^{\circ}C$

dT/dt = Temperature rise rate, $^{\circ}C/sec$

s = Front surface and

b = Back surface.

At thermal equilibrium, dT/dt vanishes so the last term in equation (2) may be dropped. Target tests have shown that equilibrium is reached after approximately 10 to 15 minutes. In the following analysis, it is assumed that equilibrium has been attained. Expanding equation (2) yields

$$Q_{in} = \epsilon_s A_s T_s^4 + \epsilon_b A_b T_b^4 + h_s A (T_s - T_o) + h_b A (T_b - T_o) \quad (3)$$

Where the four right-hand side terms correspond to the four right-hand side terms of equation (2). The term T_o is the air temperature. The power

input to the target will be supplied by radiation from the surroundings and also by electrical heating. Reference 2 considers the case of a clear sky at the low temperature of space with the ground at 20°C and air at 15°C. With no electrical heating, the target surface equilibrium temperature in the referenced report was shown to be a few degrees below 15°C because of the clear cold sky. The effect of cloud cover is included in the present analysis by assuming a single ambient temperature for the entire surroundings and air. With this assumption, the thermal input is chosen to be the sum of the electrical power and the radiation to both surfaces from the surroundings, or

$$Q_{in} = Q_{elec} + 2\rho A\sigma T_0^4 \quad (4)$$

The ρ term is absorptivity which at equilibrium is equal to emissivity.

From equations (3) and (4), assuming $h_s = h_b = h$, $\rho = \epsilon$, and h is the heat transfer coefficient.

$$q_{elec} \triangleq \frac{Q_{elec}}{A} = \epsilon_s \sigma (T_s^4 - T_0^4) + \epsilon_b \sigma (T_b^4 - T_0^4) + h(T_s - T_0) + h(T_b - T_0) \text{ (watts/m}^2\text{)}. \quad (5)$$

A second relation can be obtained by considering the heat flow through the target plywood. Assuming that power is supplied electrically only on the front surface, it is evident that the net power lost from the back side must be conducted through the plywood. Thus, we can equate

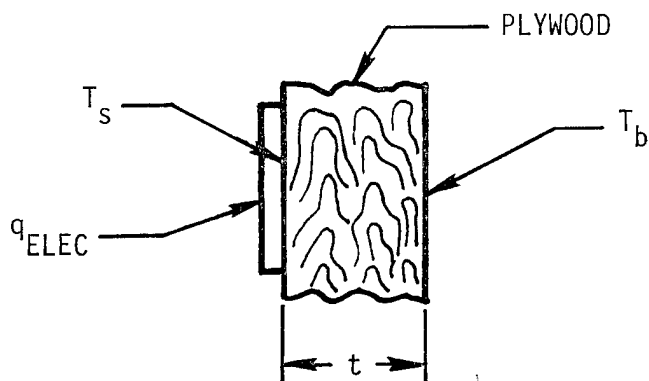

backside
power loss
(watts/m²)

$$= \epsilon_b \sigma (T_b^4 - T_0^4) + h(T_b - T_0)$$

$T_0 = 22^\circ\text{C} = \text{AMBIENT TEMP.}$ $h\left(\frac{\text{watts}}{\text{m}^2 \cdot ^\circ\text{C}}\right) = 5.7 + 3.8 V \text{ (M/sec)}$

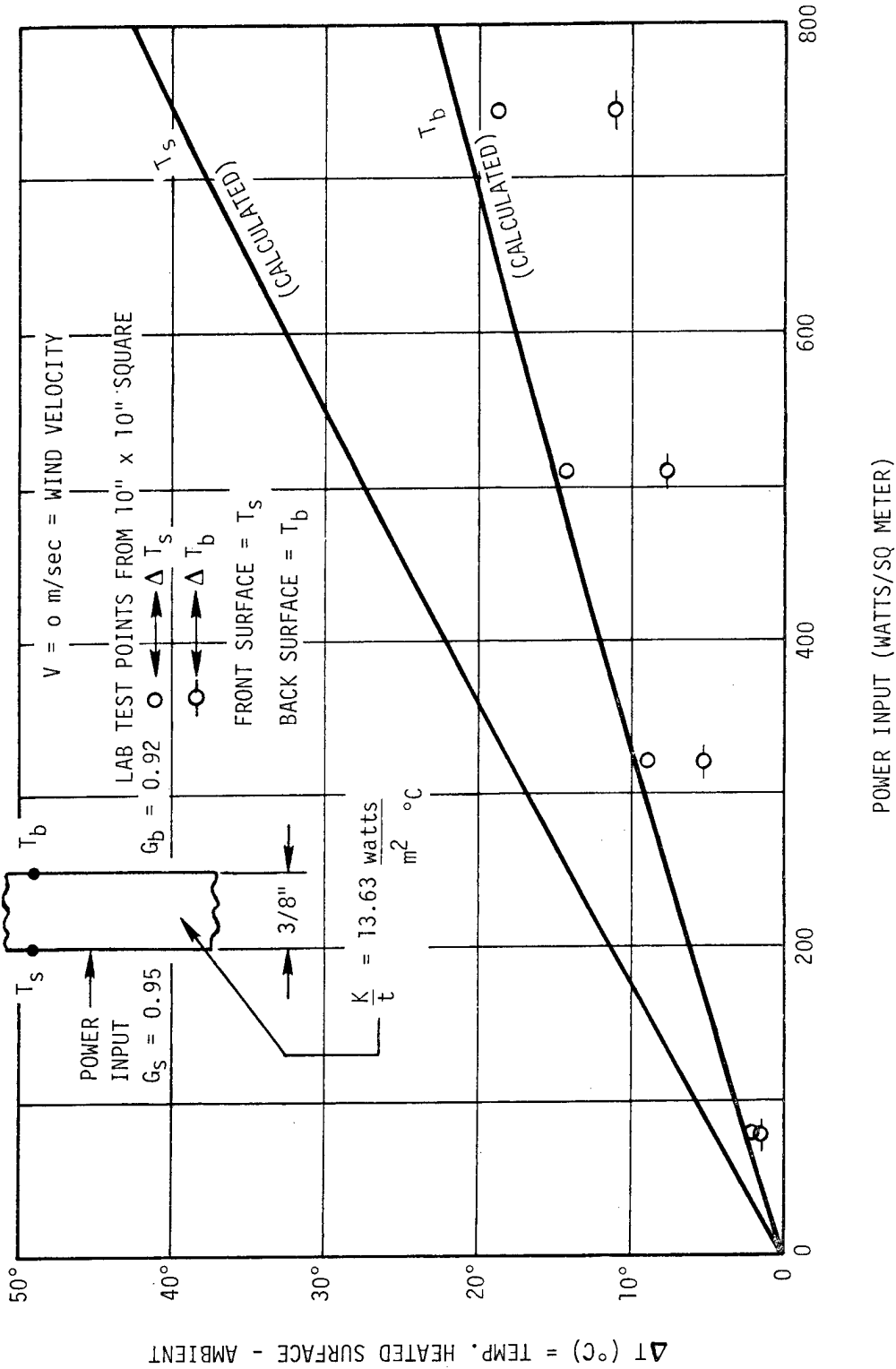

Figure III-1. Calculated Temperature Rises on the Front and Back Surface of a Target Versus Power Input

$h_c \text{ (watts/m}^2\text{)} = 8.6 + 3.8 V \text{ (m/sec)}$

○ LAB TESTS ON 10" x 10" SHEET
FRONT SURFACE, ΔT_s

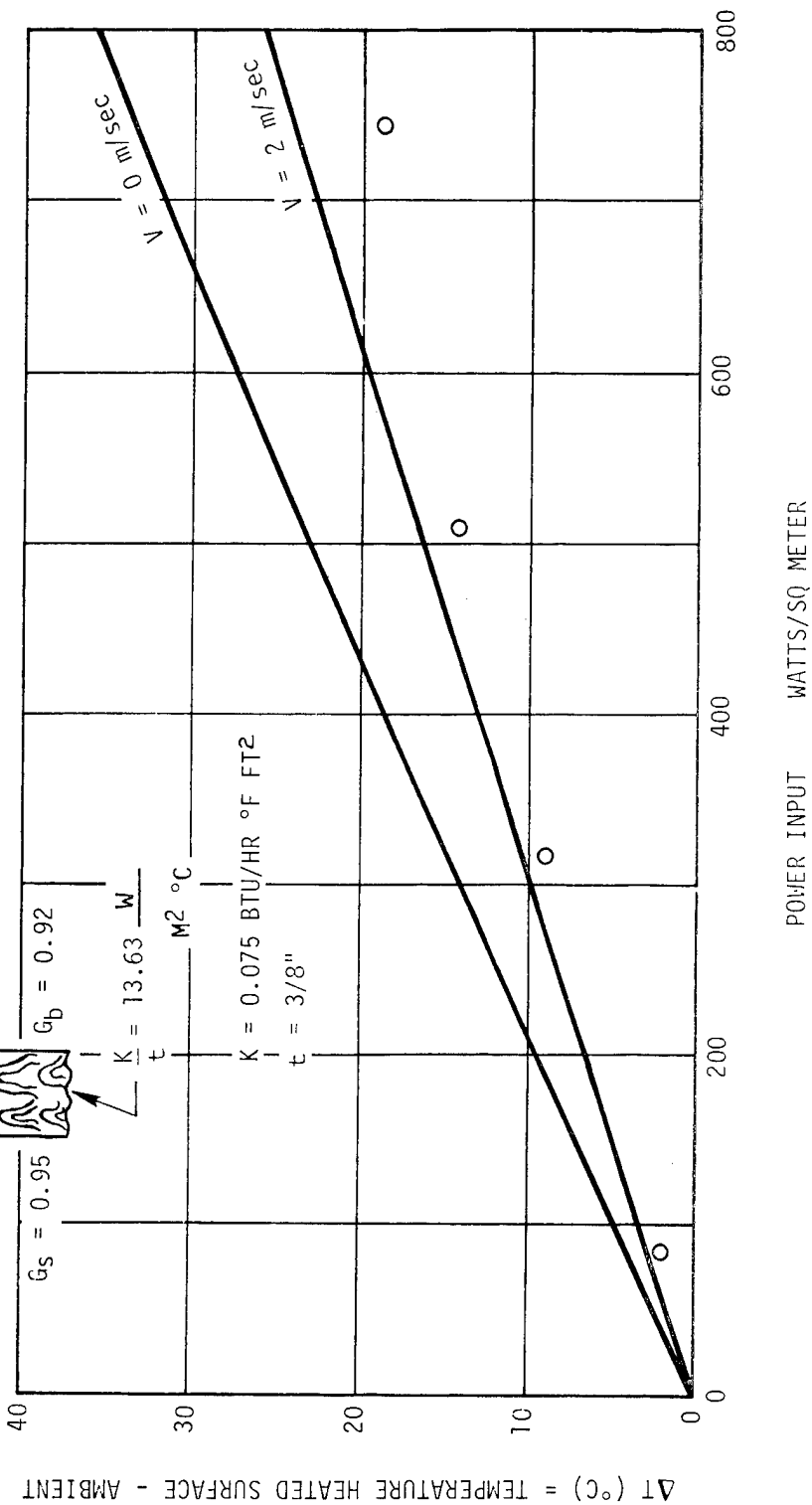
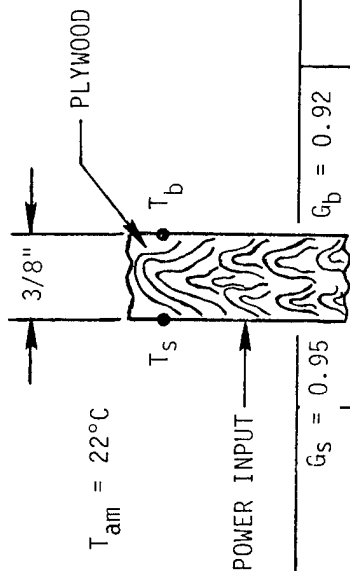

Figure III-2. Calculated Temperature Rises Versus Power Input with Wind Losses Considered

to the

$$\begin{aligned} \text{Power} \\ \text{conducted} \\ \text{(watts/m}^2\text{)} \end{aligned} = \frac{k}{t} (T_s - T_b)$$

where k is thermal conductance, watts/m($^{\circ}$ C), and t is the plywood thickness, in meters.

$$\text{Thus, } \frac{k}{t} (T_s - T_b) = \epsilon \sigma (T_b^4 - T_o^4) + h(T_b - T_o) \quad (6)$$

There are no data readily available for k and h for the models as fabricated. McAdams, reference 3, indicates that for oak ϵ is 0.90. Plywood would appear to be somewhat more porous with a resulting slightly higher emissivity. McAdams gives the thermal conductivity, k , of white fir at 0.062 Btu/ft($^{\circ}$ F)hr or 0.107 w/m($^{\circ}$ K) and oak at 0.12 Btu/ft ($^{\circ}$ F)hr or 0.208 watts/m($^{\circ}$ K). The glue in plywood raises its density and k might be expected to have an intermediate value between that of white fir and oak.

Duffie and Beckman, reference 2, give the convective heat transfer coefficient as

$$h(\text{w/m}^2(\text{^{\circ}C})) = 5.7 + 3.8V(\text{m/sec}). \quad (7)$$

No consideration was made of any scale or Reynold's Number effect, but one would expect small models to have a thinner boundary layer and consequently higher values for h than with larger models. There appears to be some experimental verification for this expectation. See the section on test results.

Appendix A gives details of the solution of equations (5) and (6). Figures III-1 and III-2 show calculated temperature rises for selected parameter sets.

The electrical power input to the target causes the surface temperature to rise; this increases the emitted electromagnetic radiation which allows the target to be viewed through the thermal sight. In the present target design, the input power is provided electrically. Power is equal to the product of applied volts times amperes.

The input power may be adjusted in the design process by selecting the proper target resistance as seen at the electrical input terminals. A metal target would have a low resistance and require large currents to provide the needed input power. A bare plywood target would not conduct sufficient current at safe voltages because of the high resistance. Reasonable resistance can, however, be obtained by covering a plywood target with a carbon filled material either as paint or as a separate layer of carbon impregnated paper.

The coverings used for the first full scale targets were:

- (a) Eccocoat SEC Carbon Latex Paint, Emmerson and Cuming
- (b) Temsheet 60 /square Paper, Armstrong Cork.

The most important electrical characteristic of the above materials is resistance in ohms per square. Consider a rectangle of electrically conductive material of uniform thickness, t , (m) and resistivity,

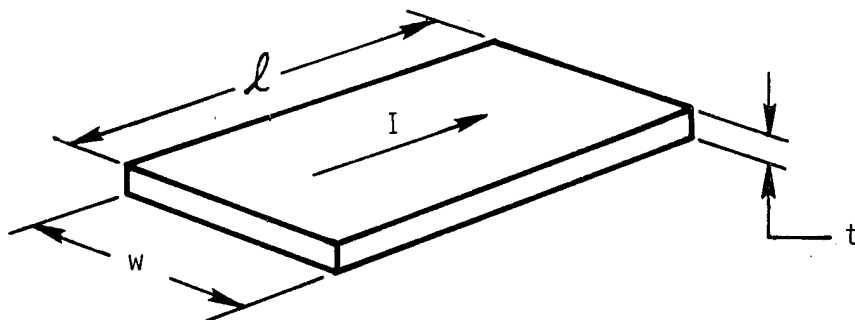

The resistance of this rectangle is

$$R(\Omega) = \frac{\rho(\Omega\text{-m}) l(\text{m})}{A(\text{m}^2)}$$

where A is the area of the surface through which the current flows. Here $A = w(\text{m}) t(\text{m})$ or

$$R(\Omega) = \frac{\rho l}{wt} \tag{8}$$

If $w = l$, the rectangle becomes a square and

$$R' \triangleq \frac{\rho(\Omega\text{-m})}{t(\text{m})} \tag{9}$$

Note that the result, R' , is independent of the l dimension and holds for any square from the largest to the smallest. The only parameters of importance for a square are the thickness of the conductive surface and the resistivity of the material.

Because the resistance of the layer is the same for any square, the term "ohms per square" is commonly used. In this report, it is represented by the letter symbol R' . The resistance of a rectangular layer is easily calculated by multiplication of the ohms per square by the number of squares in series and division by the number in parallel, l/w . For example, a sheet of 60Ω per square Temsheet 15.5 inches long and 36.7 inches wide would have

a resistance of $60 \times 15.5 / 36.7 = 25.3 \Omega$. SEC paint has a resistivity $\rho = 0.6$ ohm - cm and a layer of SEC paint, 4 mils thick, is stated by the manufacturer to give $60 \Omega/\text{sq}$. Two coats, brush applied directly to unprimed plywood at NAVTRAEQUIPCEN give results in the 250 to $300 \Omega/\text{sq}$ range. Some of the paint must fill the surface pores and the effective thickness is 20μ or 0.002cm. The second coat may be applied after a two-hour first coat drying time, and provides a usable conductive layer.

C. DESCRIPTION OF THE TARGET MATERIALS

Two different target materials were utilized to construct the prototype targets. These materials are described next.

1. TEMSHEET

Temsheet is a thin, highly flexible sheet material for low-cost electrical resistance heating. It can produce heat over large areas with less than 2 percent deviation from point to point.

Temsheet used on this project has a nominal resistance of 60 ohms per square. Thin copper strips serve as electrodes, and when these are connected to a power source, the Temsheet becomes a resistance heating element.

Temsheet contains no wires or ribbons and for that reason is free of localized hot spots, burnout and breakage problems. It can be bent around a $\frac{1}{4}$ " radius with little effect on its electrical properties.

Temsheet offers long-term stability. At 150 F, for example, stability is measured in tens of years. At 200 F, stability is measured in months.

Temsheet is available from Armstrong in rolls up to 900 feet long and widths of one, two, four, and six feet. Tables III-1 and III-2 show the electrical and physical properties of Temsheet.

TABLE III-1. TEMSHEET ELECTRICAL CHARACTERISTICS

Resistance:

Nominal, 60 ohms/square at 75 F.

Temperature Coefficient:

Resistance decreases 3% for 100 F rise in zero F to 220 F range.

Uniform Conductivity:

Within 2% from point to point over typical sheet, regardless of direction of current flow in plane of sheet.

Power Level: Varies with applied voltage and electrode spacing.

Type of Current: Works on either AC or DC.

TABLE III-2. TEMSHEET PHYSICAL PROPERTIES

Uniform Gauge:

Nominal 0.031" thickness controlled to $\pm .0015$. Selected sheets uniform to $\pm .001$.

Flexible:

Can be rolled around $\frac{1}{4}$ " radius at room temperature. Withstands repetitive flexing.

Lightweight:

Approximately 0.10 lb/sq ft in nominal 0.031" thickness.

Moisture Resistant:

Properties unchanged by exposure to dampness and redrying.

Wetness will cause an increase in electrical resistance.

Temsheet can be cut with shears or knives. It can be stapled, stitched, tacked, or punched with holes. Temsheet has unusual ability to make solid contact with common metal foils used as electrodes.

2. ECCOCOAT SEC (Electrically Resistive Paint Coating). Eccocoat is a single component paint material which can be applied to a surface to produce an electrically resistive flexible film. This paint is based on latex, and contains water and can be diluted with water.

Eccocoat may be applied by brush or spray and cures at room temperature to a tough solvent and chemically resistant film. It has excellent adhesion to most materials and exhibits good weatherability. It can be applied to large areas to act as an electrically resistive coating.

TABLE III-3. ECCOCOAT

Properties

Color	Black
Surface Resistivity, 4 mil film, ohms/sq.	60
Volume Resistivity, ohm-cm	0.6
Elongation, %	100

Before application, the surfaces to be coated should be free of oil, grease and foreign matter. Eccocoat SEC as received in the shipping container will have some settlement. It is absolutely essential for proper results to mix the entire contents to a uniform consistency before painting. The paint can be applied by brush, roller or spray. If viscosity adjustment is required for spraying, add a small amount of clean cool water and again mix thoroughly. Coating will dry tack-free in one hour; complete cure will develop in 24 hours. To seal porous surfaces, multiple coats are required. Allow at least two hours between coats.

D. DESIGN EXAMPLES

This section includes two design examples using the resistive heating materials discussed in the previous section.

Various temperature gradients on the surface of a thermal target can be established by properly selecting the location of electrodes on the targets surface. If the targets electrodes have a configuration as pictured below, we have essentially four squares in parallel.

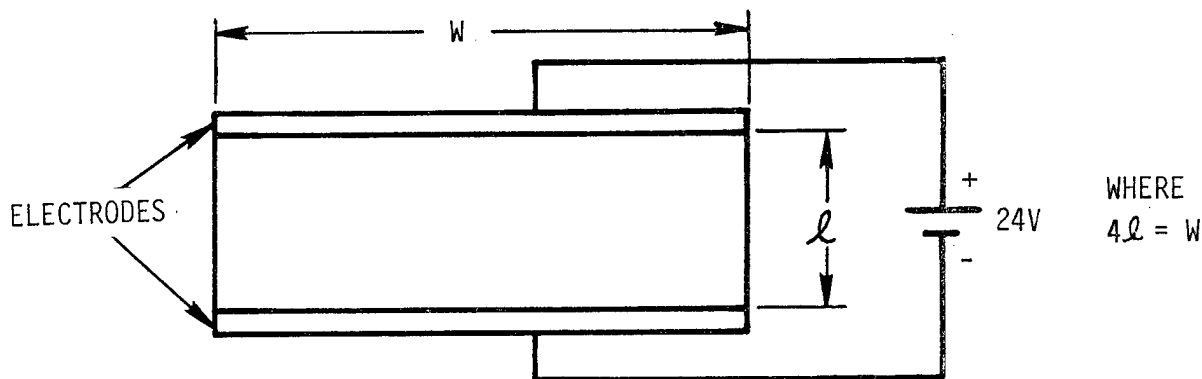

The electrical equivalent circuit analogy for this case is shown below.

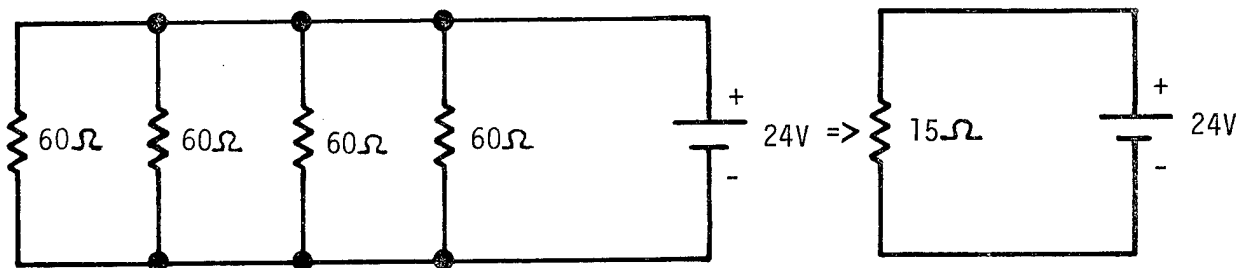

Assuming the resistance of a single square is 60 ohms, the equivalent resistance of the four resistors in parallel is 15 ohms.

Power input to this configuration is then

$$P = EI = \frac{E^2}{R} = \frac{(24)^2}{15} = 38.4 \text{ watts}$$

If the configuration of the electrodes are as shown below, we now have four squares in series.

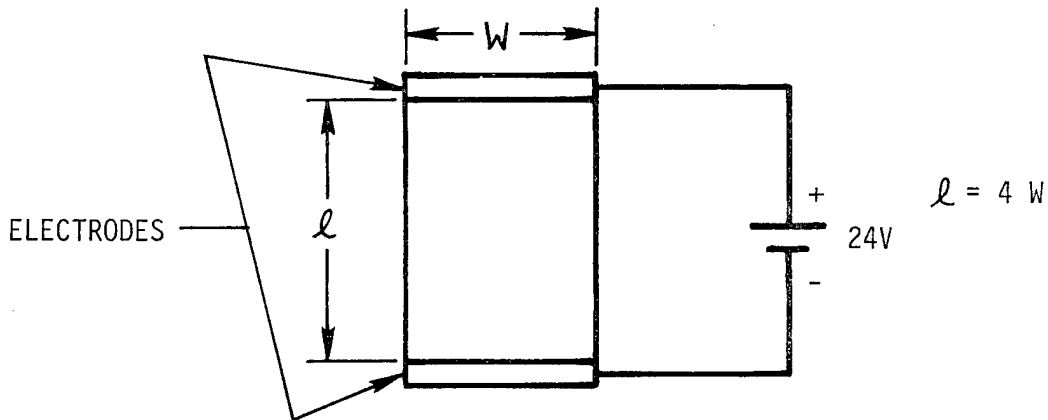

The electrical equivalent circuit analogy for this case is

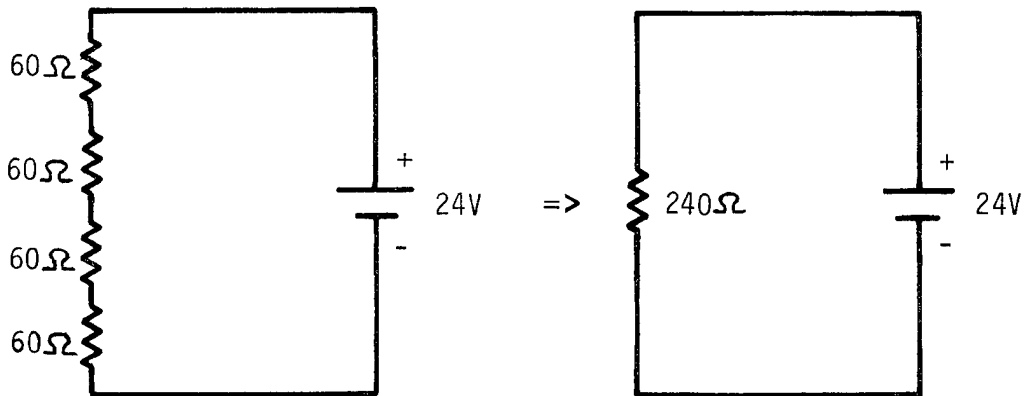

Power input to this configuration is then

$$P = \frac{(24)^2}{240} = 2.4 \text{ watts}$$

The above examples were given to illustrate how the configuration of electrodes on the target material can change the power and hence the radiation emitted. Using this information, two designs will be illustrated next.

1. DESIGN EXAMPLE I

As an example of a design using a resistive material, consider the design of the engine compartment area. The dimensions are to be 5 feet long by 1 foot high, and it is desired to select a suitable voltage to apply to 60 ohms per square Temsheet. For a temperature rise of 5°C, 9°F, the required input power is conservatively estimated to be 200 watts per square meter. We will now calculate the electrical potential V to achieve this condition.

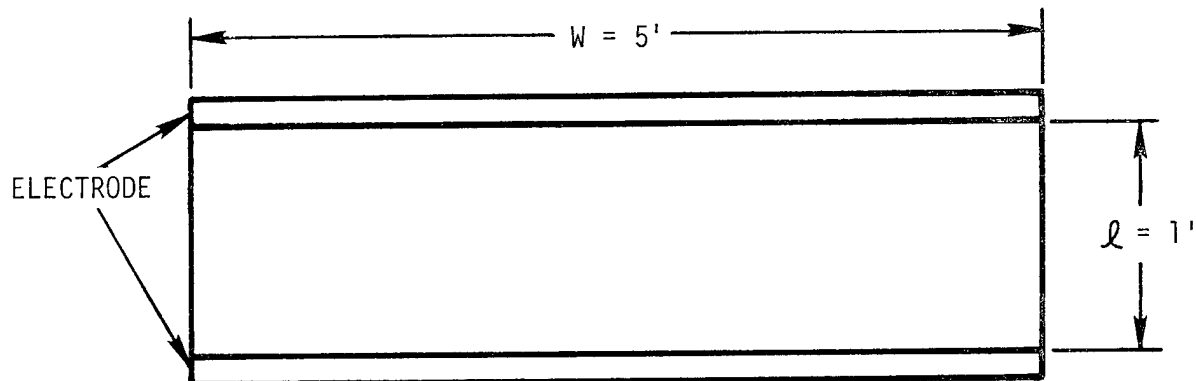

The input power density to the rectangle is

$$p(W/m^2) = \frac{P(w)}{(m)w(m)} = \frac{\Delta V(\text{volts})^2}{R(\Omega)lW}$$

From equations (8) and (9)

$$R(\Omega) = R'(\Omega \text{ per sq}) \frac{l}{W}$$

and

$$p(W/m^2) = \frac{(\Delta V)^2}{R'l^2}$$

Finally

$$\Delta V(\text{volts}) = l(m) \sqrt{p(W/m^2) R'(\Omega \text{ per sq})} \quad (10)$$

From (10) with $l(m) = 1 \text{ (ft)} = 0.3048 \text{ (m/ft)} = 0.3048 \text{ m}$

$$V = 0.3048 \sqrt{200 \times 60} = 33.39 \text{ volts} \Rightarrow 33.4 \text{ volts}$$

2. DESIGN EXAMPLE II

A more complex problem is encountered in the design of nonrectangular surfaces such as the vehicle wheels. For example, it might be required to select a wheel hub diameter for one of the 30-inch diameter wheels for use with 110 volts when the conductive surface is two uniform coats of Eccocoat SEC latex paint having a resistance of $300 \Omega/\text{sq}$. The desired average input power is to be $400 \text{ watts}/\text{m}^2$.

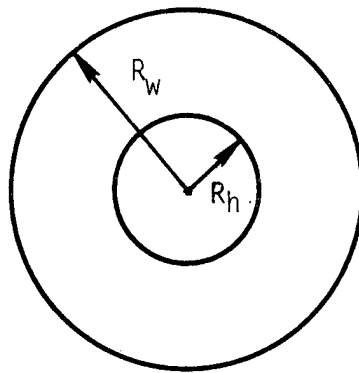

$$R_w = 15.5''$$

$$R_h = 3.5''$$

Current I flows from the rim to the hub in a symmetric manner and because of Kirchhoff's Current Law, the current density

$$j \left(\frac{\text{Amp}}{\text{m}^2} \right) = \frac{I}{2\pi r t}; \quad r_h \leq r \leq r_w$$

where t is the paint thickness.

From Ohms law

$$j \left(\frac{\text{Amps}}{\text{m}^2} \right) = - \frac{1}{\rho (\Omega \cdot \text{m})} E (\text{v/m})$$

where ρ is the paint resistivity and E is the radial voltage gradient. Because $E = dv/dr$

$$\int_{r_w}^r dV = \int_{r_w}^r E(r) dr = \int_{r_w}^r - \frac{\rho I}{2\pi r t} dr$$

Thus

$$V(r_w) - V(r) = \frac{\rho I}{2\pi t} \int_{r_w}^r \frac{dr}{r} = \frac{\rho I}{2\pi t} \text{Ln} \frac{r}{r_w} \quad \text{and}$$

$$V(r_w) - V(r_h) = \frac{\rho I}{2\pi t} \text{Ln} \frac{r_w}{r_h},$$

substituting $R' = \rho/t$ in ohms/sq

$$V(r_w) - V(r_h) = \frac{R'}{2\pi} I \ln \frac{r_w}{r_h}.$$

The effective resistance of the wheel

$$R_{\text{eff}} = \frac{V(r_h) - V(r_w)}{I} = \frac{R'}{2\pi} \ln \frac{r_w}{r_h}.$$

See figure III-3.

The average power loss is

$$P_{\text{avg}}(\text{watts}) = \frac{(\Delta V)^2}{R_{\text{eff}}} = \frac{2\pi(\Delta V)^2}{r' \ln\left(\frac{r_w}{r_h}\right)}$$

and letting the power density, $\bar{p} = \frac{P_{\text{avg}}}{\text{wheel area}}$ we have

$$\bar{p} \left(\frac{\text{watts}}{\text{m}^2} \right) = \frac{P_{\text{avg}}}{\pi(r_w^2 - r_h^2)} = \frac{2(V)^2}{\pi(r_w^2 - r_h^2)R' \ln \frac{r_w}{r_h}}$$

or r_h is the solution to

$$\left[1 - \left(\frac{r_h}{r_w} \right)^2 \right] \ln \left(\frac{r_w}{r_h} \right) = \frac{2(V)^2}{r_w^2 P R'}$$

the right hand side is $\frac{2 \times 110^2}{0.381^2(\text{m}) \times 400 \times 300} = 1.39.$

The solution to this nonlinear equation can be shown to be

$$\frac{r_h}{r_w} = 0.23$$

and

$$R_{\text{eff}} = \frac{300}{2\pi} \ln \left(\frac{1}{0.348} \right) = 70.2 \Omega$$

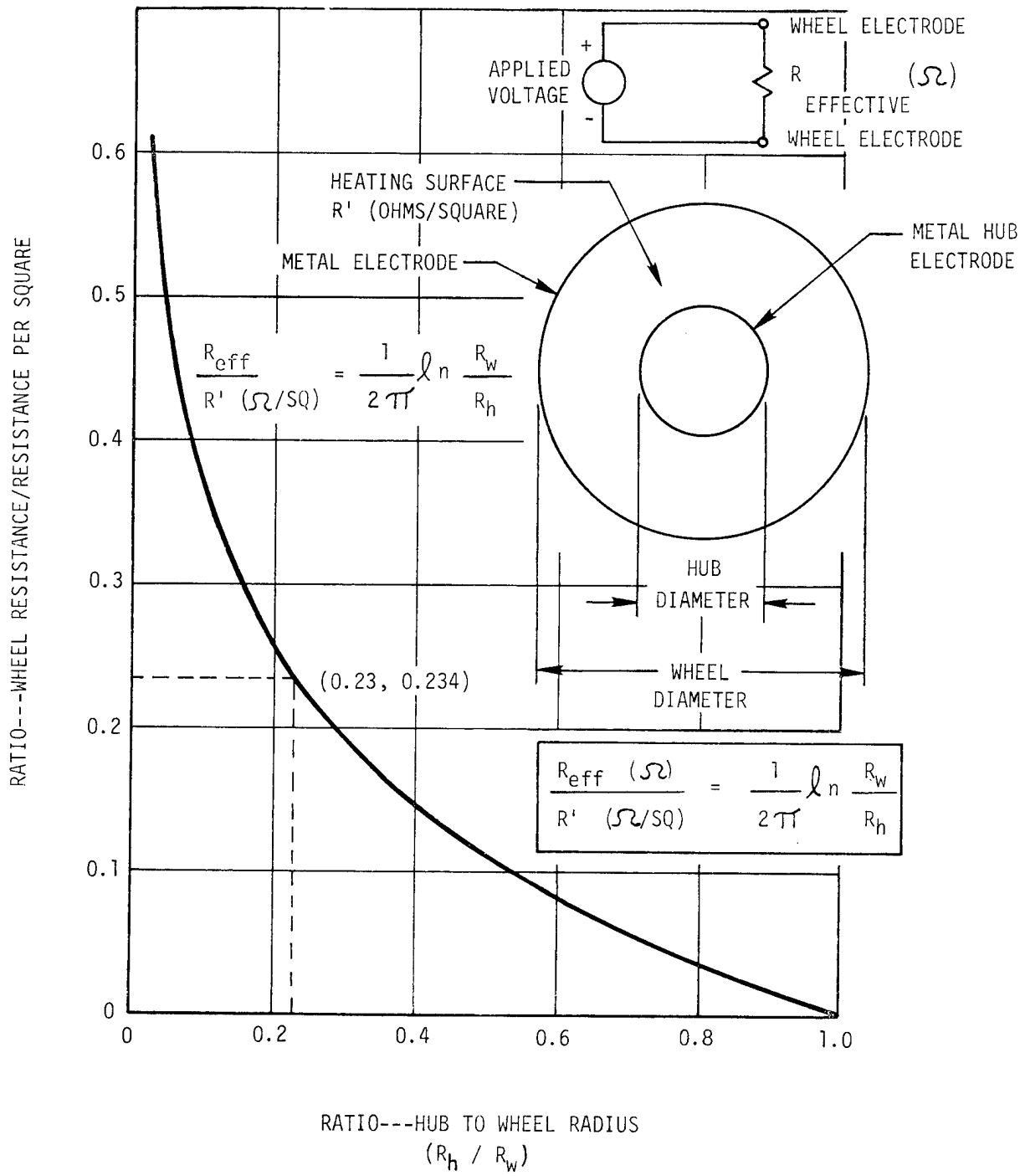

Figure III-3. Effective Wheel Resistance

The power density

$$\begin{aligned}
 p(w/m^2) &= \int_{(r_2-m)}^{\left[j \left(\frac{A}{m^2} \right) \right]^2} t(m) \\
 &= R' \left[\frac{I}{2\pi r t} \right]^2 t^2 = \frac{I^2 R'}{(2\pi r)^2} \\
 p(w/m^2) &= \left(\frac{\Delta V}{R_{\text{eff}}} \right)^2 \frac{R'}{(2\pi r)^2} = \frac{(\Delta V)^2 / R'}{\left[r \ln \frac{r_w}{r_h} \right]^2} \quad (11) \\
 &= \left(\frac{110^2 / 300}{\ln 4.35} \right) \frac{1}{r^2} = \frac{27.4}{r^2} \text{ watts/m}^2 \text{ re } [r_h, r_w] = [0.2655, 0.762].
 \end{aligned}$$

Or with $r_w = 0.381$ meters (15 inches)

$$p(w/m^2) = \frac{189.1}{(r/r_w)^2}; \quad 0.23 \leq \frac{r}{r_w} \leq 1.$$

Table III-4 shows calculated power and temperature distribution for this design. Based on the results of tests on the 10" X 10" square, the expected temperature rises should be about half the calculated values.

TABLE III-4. CALCULATED POWER AND TEMPERATURE DISTRIBUTION

r/r_w	$p(w/m^2)$	ΔT calculated $^{\circ}C$	ΔT expected $^{\circ}C$
1.0	189.1	10.5	5.2
0.9	233.5	12.9	6.5
0.8	295.5	16.2	8.1
0.7	385.9	21.0	10.5
0.6	525.3	28.2	14.1
0.5	756.4	39.7	18.8
0.45	933.8	48.1	24.1
0.40	1181.9	59.5	29.7
0.35	1543.7	75.0	37.6
0.30	2101.1	97.4	48.7
0.25	3025.6	130.3	65.2
0.23	3574.7	147.9	74.0

Figures III-4 and III-5 show measured versus expected temperatures for the painted and Tensheet target. Note that the "expected" ΔT is taken as one-half of the calculated value and the measured values are still lower. There is little question about measurement of the electrical input power. The analysis neglects heat flow parallel to the target surface which may explain "end effects" such as why essentially no ΔT was measured near the wheel rim. Otherwise, the shape of the measured ΔT curves is similar to predicted. The poor quantitative results are probably due to poor temperature measurement and/or poor heat transfer data. The resolution of these discrepancies, while interesting, is probably of more academic than practical interests.

E. SCALED MODELS

Small scale models can be used on scaled firing ranges or to predict the performance of a thermal target. Scale effects can be demonstrated from equation (11) for a wheel and equation (10) for a rectangle. Equation (11) when solved for ΔV yields

$$\Delta V = \eta_{Ln} \left(\frac{r_w}{r_h} \right) \sqrt{P R'}$$

and from equation (10)

$$\Delta V = L \sqrt{P R'}$$

Both of these equations are of the form

$$\Delta V = K L \sqrt{P R'} \quad (12)$$

where K is a factor or proportionality, $K = 1$ for a rectangle and $K = L_n (r_w/r_h)$ for a wheel. L , the characteristic length is the path length, l , for a rectangle and the radius to the point of interest for the wheel or any annular surface. In both cases, p is power density, watts/m², and R' is the characteristic resistance, ohms per square, of the electrically conductive surface.

While equation (12) evidently holds for rectangles and annular surfaces (wheels), it also applies for any geometrically similar surfaces as may be demonstrated by dimensional analysis.

Letting subscripts "f" and "m" represent full scale and model characteristics, equation (12) gives

$$\frac{\Delta V_f}{\Delta V_m} = \frac{L_f}{L_m} \sqrt{\frac{P_f R'_f}{P_m R'_m}}$$

because $K_m = K_f$ for geometrically similar models.

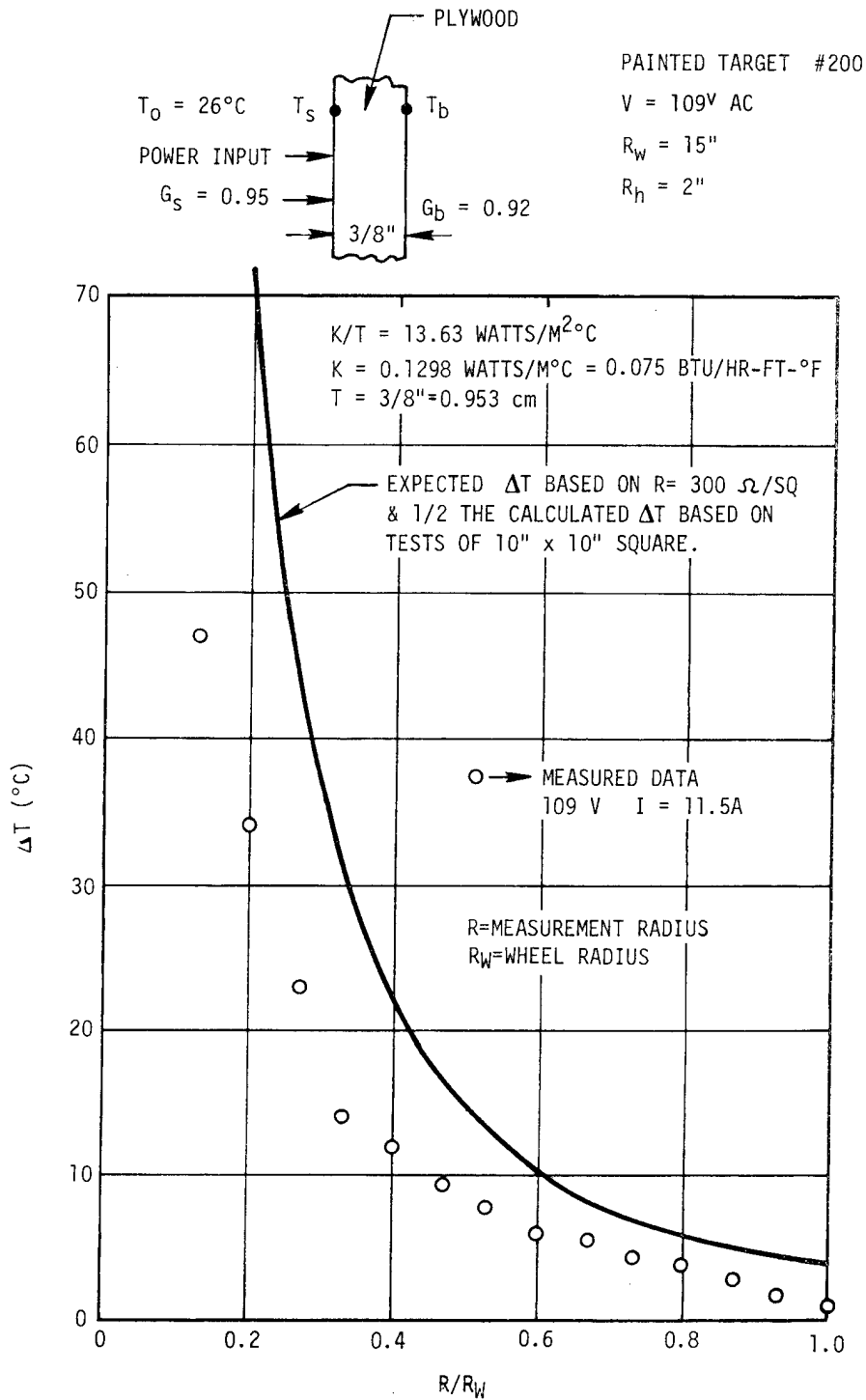

Figure III-4. Temperatures Both Calculated and Measured on a Wheel (Paint Target)

TEM SHEET TARGET

#201 V = 38.8V

$R_w = 15''$

$R_h = 2''$

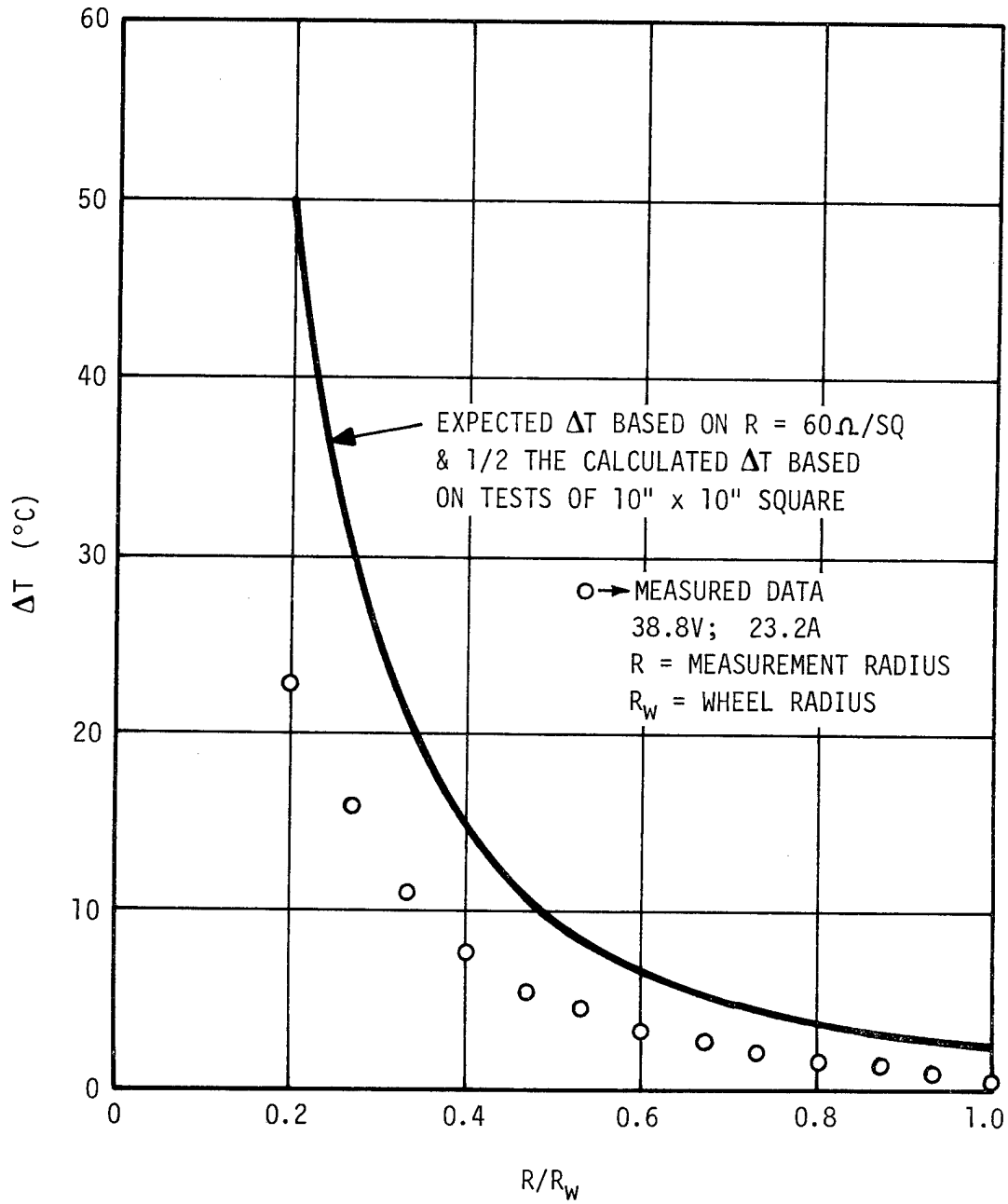

Figure III-5. Temperatures Both Calculated and Measured on a Wheel (Temsheet)

Assuming it is desired to operate both full and small scale models at the same power density to obtain comparable surface temperature rises, $P_f = P_m$. In this case

$$\frac{\Delta V_f}{\Delta V_m} = \frac{L_f}{L_m} \sqrt{\frac{R_f}{R_m}} \quad (13)$$

For example, thermal sight viewing of a 1/3rd scale model showed that satisfactory visibility was obtained with $\Delta V = 35$ volts. Because $L_f = 3L_m$,

$$\Delta V_f = 35 \times 3 \sqrt{\frac{R_f}{R_m}}$$

If the same surface treatment is to be used for both full and scale models, $R_f = R_m$ and

$$\Delta V_f = 105 \text{ volts}$$

Equation (13) is, evidently, very useful in extrapolating model results to full scale.

F. TARGET TEMPERATURE CONTROL

The visibility of a target is dependent upon surface temperature rise above ambient, background emissivity, wind, sun and sky brightness as well as thermal sight parameters.

Power input to the target serves as the control variable and a hypothetical closed loop target control system might be represented as:

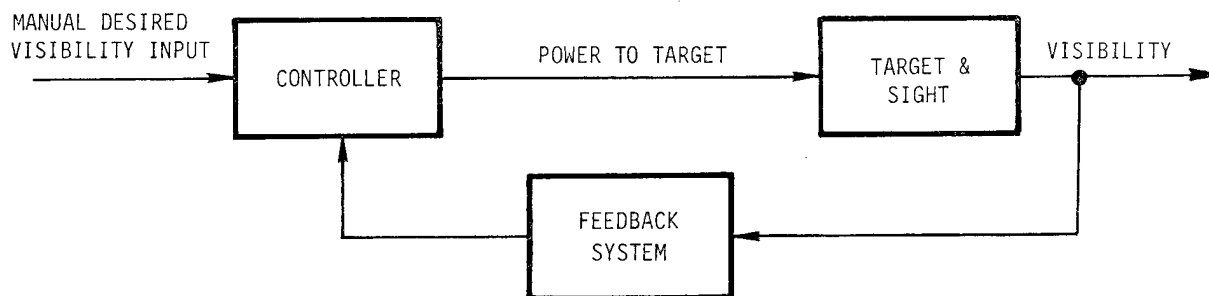

Such a system would provide all the usual benefits of feedback such as insensitivity of the system to:

- Target surface preparation
- System aging
- Power supply voltage
- Target damage

The measurement of target visibility, unfortunately, would require a modified, dedicated thermal sight trained on the target at all times as well as control lines or a radio link extending from the sight to the target. To overcome these difficulties, a closed loop may be provided to control the temperature rise above ambient of a selected point on the target surface. The temperature controller is

Model Number H1503 (modified)
Hawthorne Industries
Hollywood, Florida

Thermistor temperature sensors are used to measure both the ambient and target surface temperature. The control provides relay control of the target power, with the desired target temperature rise, ΔT , being set by a dial on the front face of the controller. Shell fire damage to the target sensor causing it to open will turn target power "on-full." Shell damage to the ambient sensor will turn target power off. Consequently, this ambient sensor must be located at a remote location protected from shell fire as far as possible.

During the tests, it was concluded that temperature controllers are not necessary under ordinary range conditions. If precise temperature differences are required, a control of this nature may be utilized.

The next section describes methods of thermal signature target construction (Section IV).

SECTION IV

CONSTRUCTION OF THERMAL SIGNATURE TARGETS

Thermal signature targets were fabricated with both "Temsheet" and "Eccocoat SEC" paint to provide the electrically heated surfaces. Both front (frontal) and side (flank) view tank targets were fabricated.

A. THERMAL SIGNATURE TARGETS (TEMSHEET) T-62 FULL-SCALE FRONTAL VIEW TARGET CONSTRUCTION

1. Cut target sections from 3/8" plywood according to frontal view figure IV-1, IV-2, and IV-3.
2. Mark plywood target with pencil lines indicating proper placement of 1/2" wide, .002" thick copper stripping.
3. Assemble the target frame according to figures IV-4 and IV-5. Use 8-penny nails to attach the 2-by-4 lumber frame pieces to themselves.
4. Lay the assembled target frame in a horizontal position with the two 8' frame members on the bottom, i.e., facing down. Next, lay the plywood target pieces (pencil markings up) on the frame and align as shown in figure IV-4. Secure the target pieces to the frame by using 4-penny nails.

NOTE: Space nails at least six inches vertically and two inches horizontally apart.

Avoid driving nails which will protrude through the bracing or target. If a nail is driven through an electrically active area on the front of the target and does protrude thru the rear bracing, there is a chance of an electrical short with the wiring on the back of the target. Therefore, any protruding nails should be replaced with shorter nails.

5. Starting with the bottom of the target, see figure IV-6. Lay a horizontal strip of 2-ft wide Temsheet across the target from left to right, end to end. You may tack it in place with a few staples.

NOTE: When tacking the Temsheet down, keep the staples horizontal with respect to the top and bottom of the target. This is necessary because the electrical current runs through the target in a vertical direction, and if the staple is vertical, then the staple will allow the current to run through itself rather than making the current run through the Temsheet.

Next, lay a horizontal 20-inch wide strip of Temsheet just above the lower piece. The seam between the two pieces of Temsheet will be covered by a strip of copper conductor running from end to end, therefore make sure the seam is straight and true.

NOTE: Do not overlap the pieces of Temsheet! If the Temsheet is overlapped, the copper strip which you will lay over the Temsheet seam will not make a good electrical contact with Temsheet.

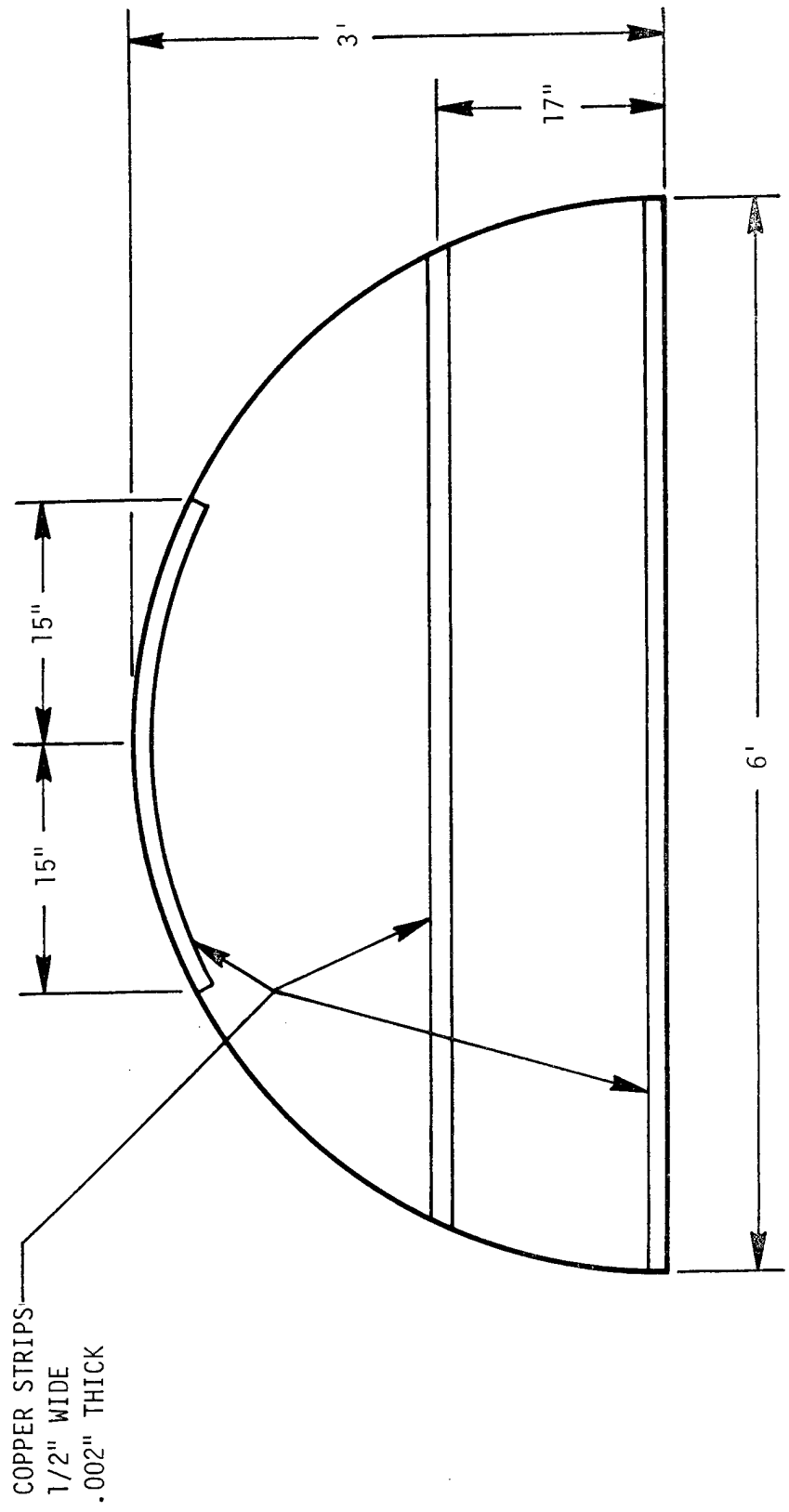

Figure IV-1. Frontal Target Turret Section (Front Side)

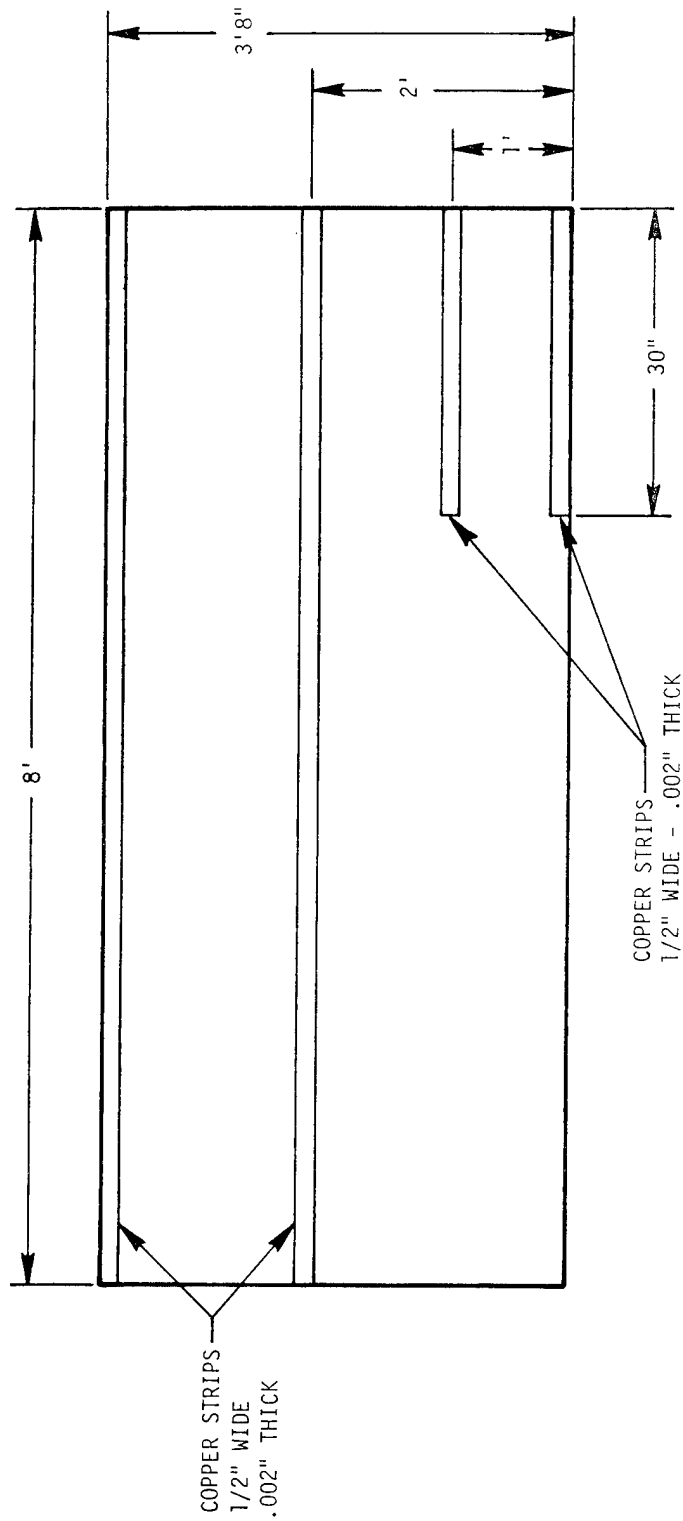

Figure IV-2. Frontal Target Right Section (Front Side)

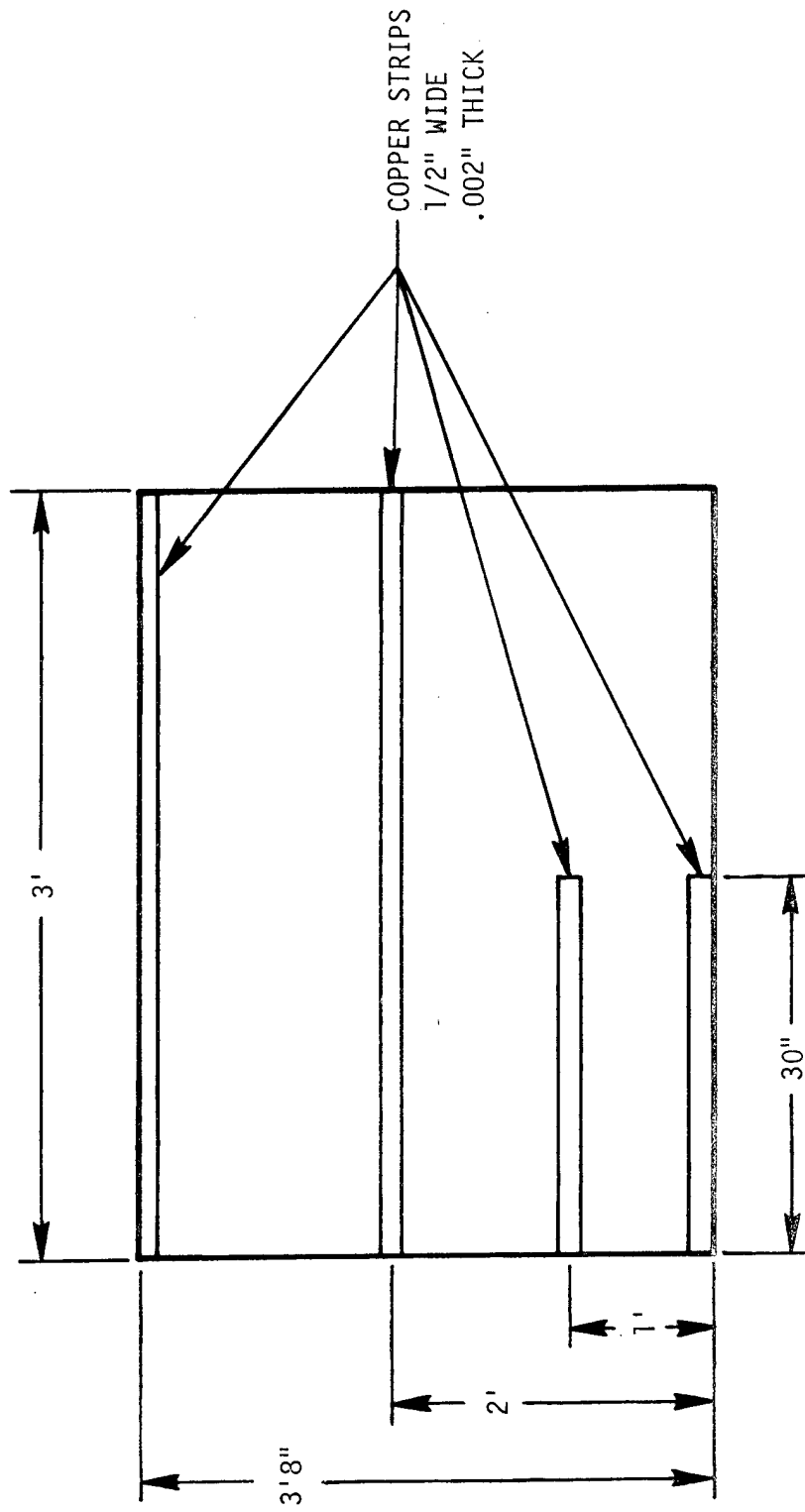

Figure IV-3. Frontal Target Left Section (Front Side)

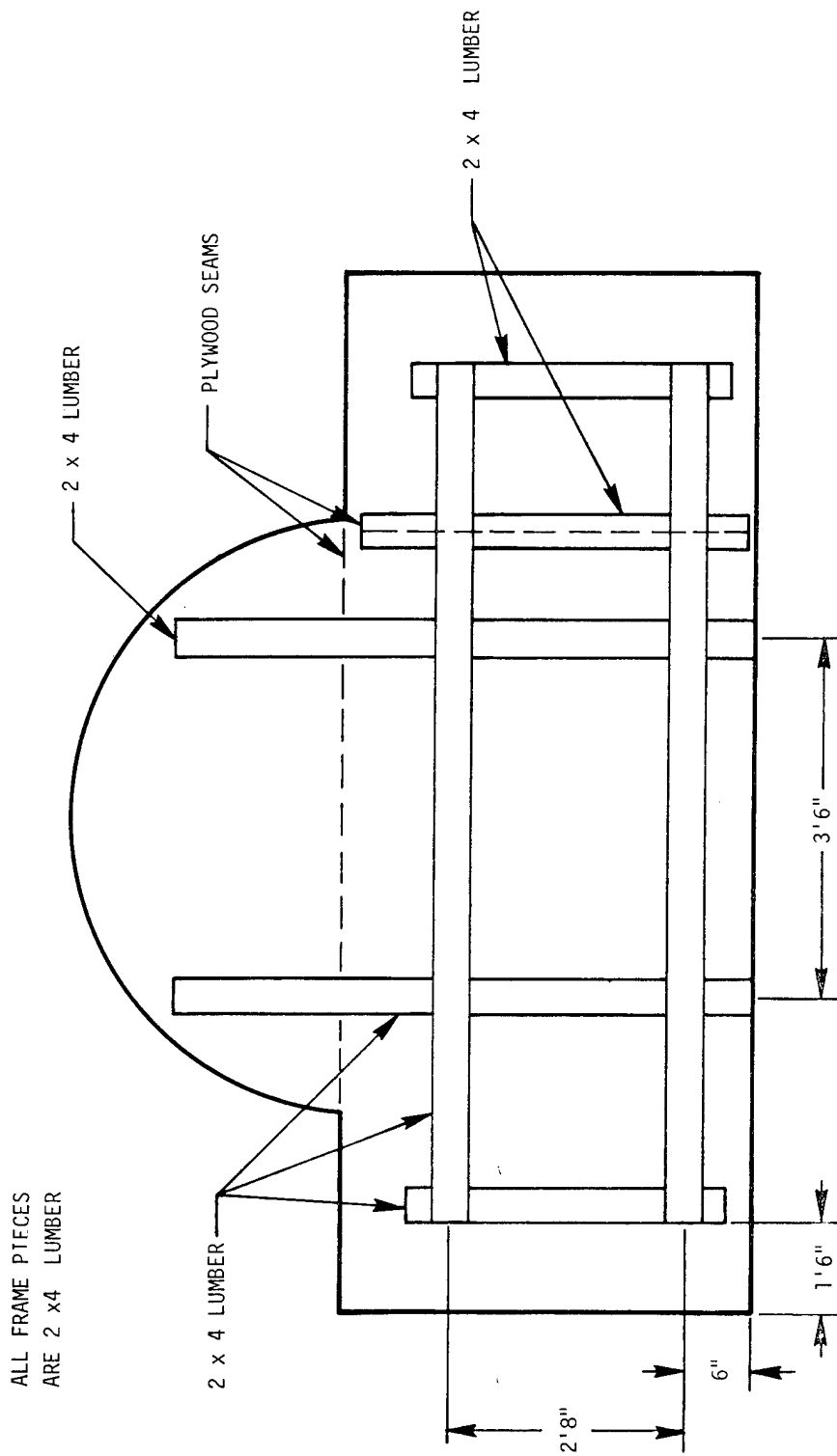

Figure IV-4. Frontal Target Frame Layout (Rear Side)

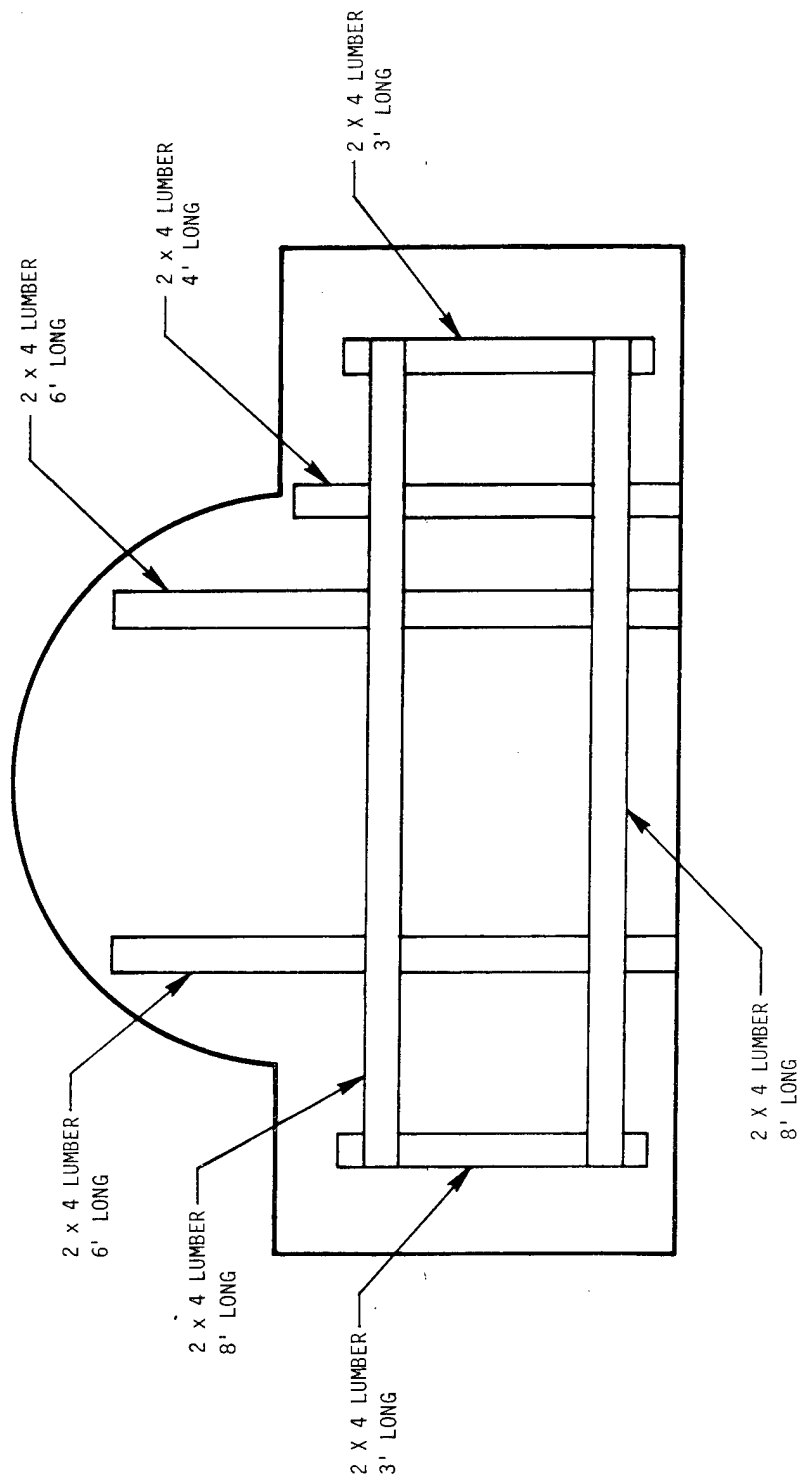

Figure IV-5. Frontal Target Frame Member Specifications (Rear Side)

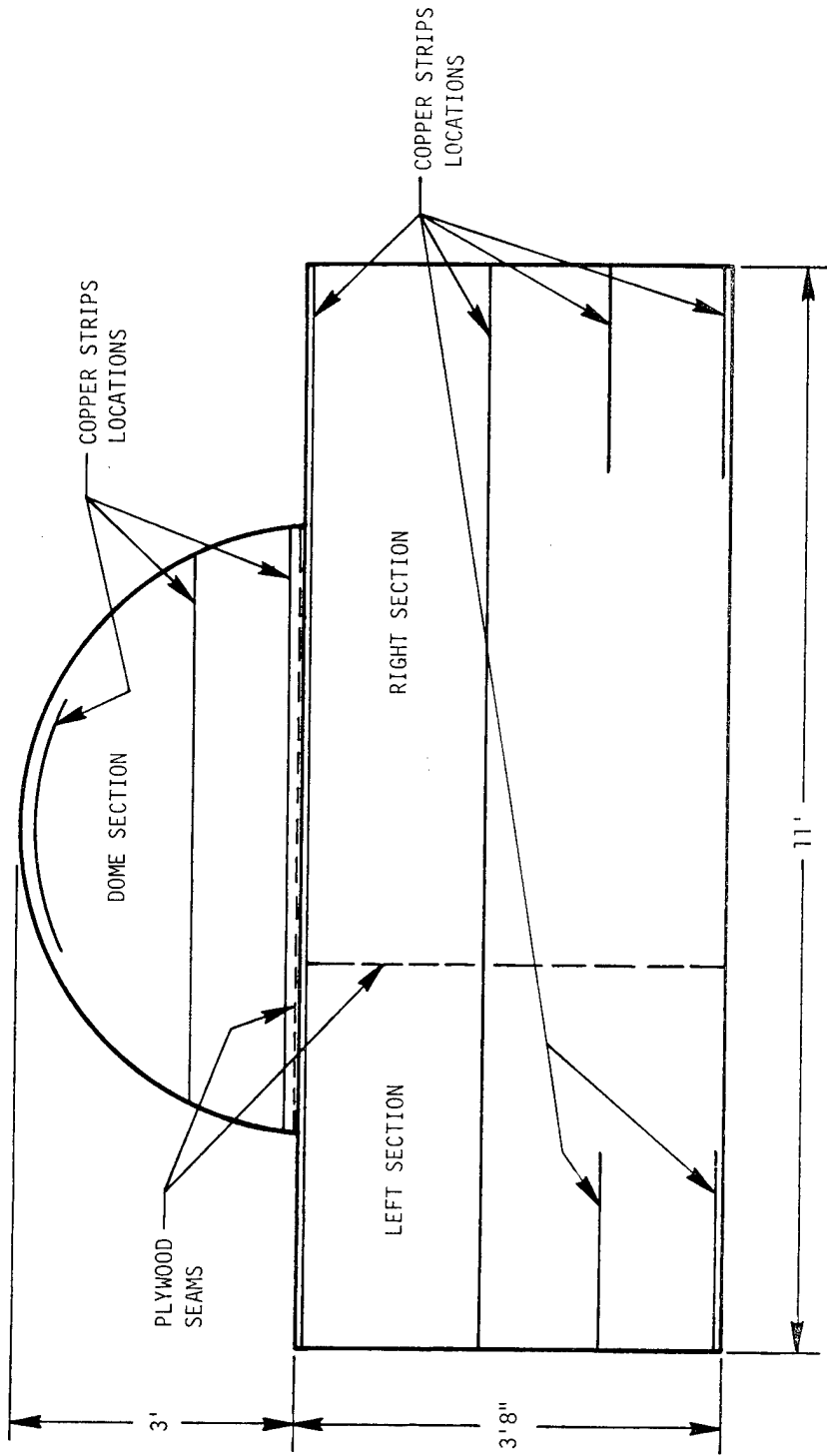

Figure IV-6. Frontal Target Piece Assembly (Front Side)

Tack down the Temsheet as required to hold it in place. Position the copper stripping on the Temsheet following the layout figures, IV-2, IV-3, and IV-6. Staple the copper stripping as shown in figure IV-7. Use 20 staples per foot.

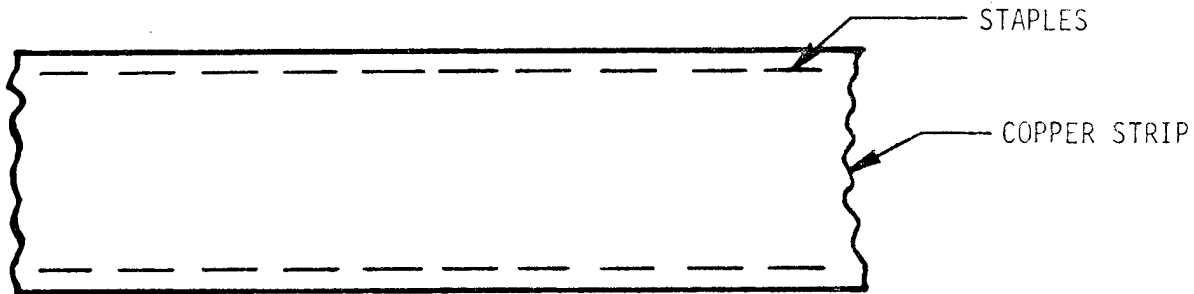

Figure IV-7. Staple Locations in Copper Electrode

6. Cover the bottom half of the dome (17" width) with a horizontal strip of Temsheet and tack in place -- see figure IV-1. Cover the top half of the dome (19" width) with another horizontal piece of Temsheet: pay special attention to matching the seam of the top and bottom half of the Temsheet to each other. Do not overlap! Tack the top half of Temsheet in place.

7. Tack down copper stripping along the seam of the Temsheet top and bottom halves. Make sure that the copper strip covers both top and bottom pieces of Temsheet along the entire length of the seam. Staple down the copper strip with the top row of staples fastening the top piece of Temsheet and the bottom row of staples fastening the bottom piece of Temsheet.

8. Apply the top and bottom copper strips to the dome, according to figure IV-1, and staple down as shown in figure IV-7 to create the arc at the top of the dome, fold the copper stripping as shown in figure IV-8.

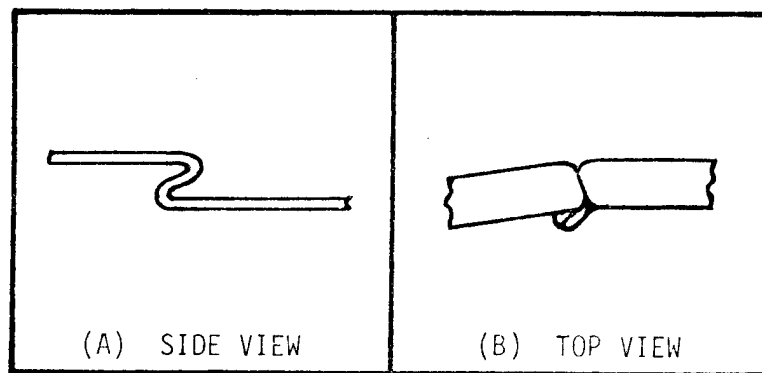

Figure IV-8. Copper Electrode Folded to Fit Curved Surface

9. Holes are now drilled from the front side of the target. Through the copper stripping using a 5/32" drill bit. The approximate hole placement is shown on figure IV-9. The exact location of these holes may depend upon frame member placement. Working from the back side, layout the aluminum tape following the pattern on figures IV-10, IV-11, and IV-12. When laying the

aluminum tape over a 2-by-4 frame member, position the tape so that it follows the contour, i.e., run the tape up the side of the 2-by-4, across, and then down the other side.

NOTE: The aluminum tape on figure IV-11 must not connect with the aluminum tape on figure IV-12.

10. Insert #6-32 machine screws, with washer on front and back, thread on the proper nut, and tighten securely. Repeat this for all connection points on the target.

NOTE: Remove all staples that are underneath the screw and washer. This will assure a good electrical connection.

11. Paint all screw heads, washers, copper stripping, and nail heads with SEC conductive paint. This is done to insure a good electrical contact of the copper stripping to the Temsheet. The painting strokes should be such as to draw the conductive paint under as well as over the edges of the copper stripping. This procedure is best performed with the target in a horizontal position.

NOTE: Frequent and thorough mixing of the SEC conductive paint is imperative to mix the carbon particles in the paint.

12. Wrap the front side of the target with bubble plastic sheet. Wrap it around top and side edges of the target and staple it on the back side of the target. A 4' wide by 11.5' long piece of bubble plastic should be used for the rectangular 'body' portion of the target and a 6.5' by 3.5' piece should be used for the 'dome' of the target.

ELECTRICAL HOOKUP OF TARGET

The frontal target requires 36 volts DC power supply. This may be obtained from three 12-volt batteries, wired in series. Figure IV-13 shows a recommended hookup procedure. Do not exceed 36 volts or three 12-volt batteries in series!

Before using the target, the following test must be performed. An ohmmeter must be attached to the completed target. This connection must be made at the same points that you will attach the battery. The resistance of a frontal target will read between 1.5 and 5 ohms. When the resistance check has been made and the resistance is found to be satisfactory, then remove the ohmmeter and the target is complete.

SOME SPECIAL NOTES

The aluminum tape makes good electrical contact on the ungummed side only. The end of the tape must be folded over (gum inside) before a piece of tape may be attached (stapled) to another piece of tape.

Any or all painting with SEC conductive paint may be delayed until the target construction is nearly complete, as this will save time and paint.

Staples should be hammered down to insure good electrical contact between the Temsheet and the copper stripping.

Twenty-four volts (two batteries in series) may be used under some environmental conditions, i.e., low wind speeds, if the thermal signature is judged adequate by the user. In some cases, under sunny daytime conditions, no battery power may be necessary due to solar heating of the target.

REPAIR

Repairs are made in the field by replacing damaged aluminum tape with new tape. This is done by using a short section of aluminum tape, with both ends folded over (gum inside), and stapling it over the damaged tape.

Copper stripping may be replaced in the same manner on the front side of the target. An ohmmeter should be used as a final check on repair work done. Connect the meter to the screws which are being used for the wires from the batteries (do this only with batteries disconnected). The ohmmeter should measure some finite value of resistance. The actual resistance will vary depending upon the number of 'hits' taken by the target. If the target is electrically shorted, then the resistance will read zero (0) ohms and the target needs further inspection and corrective action must be taken to remove the short.

*****CAUTION*****CAUTION*****CAUTION*****CAUTION*****

The batteries must not be connected to a shorted target! Permanent damage will result to the batteries and there is a chance that the batteries will explode!

B. THERMAL SIGNATURE TARGETS (TEMSHEET), T-62 FULL-SCALE FLANK VIEW TARGET CONSTRUCTION

1. Figure IV-14 shows the five sections used to construct a flank target. Cut target sections from 3/8" plywood according to flank view figures, IV-15, IV-16, IV-17, IV-18, and IV-19.
2. Mark plywood target pieces with pencil lines indicating proper placement of 1/2" wide, .002" thick copper stripping.
3. Cut out 31" diameter wheels using 60 ohm per square Temsheet.
4. Cut out 7" diameter wheel hubs from copper sheet.
5. Fit the Temsheet to form a wheel of the target. Tack down the Temsheet by positioning a wheel hub (7" disk) in the center of the wheel and tack down as shown in Figure IV-20. A few staples may be used to hold down the outer rim of the Temsheet during this operation.

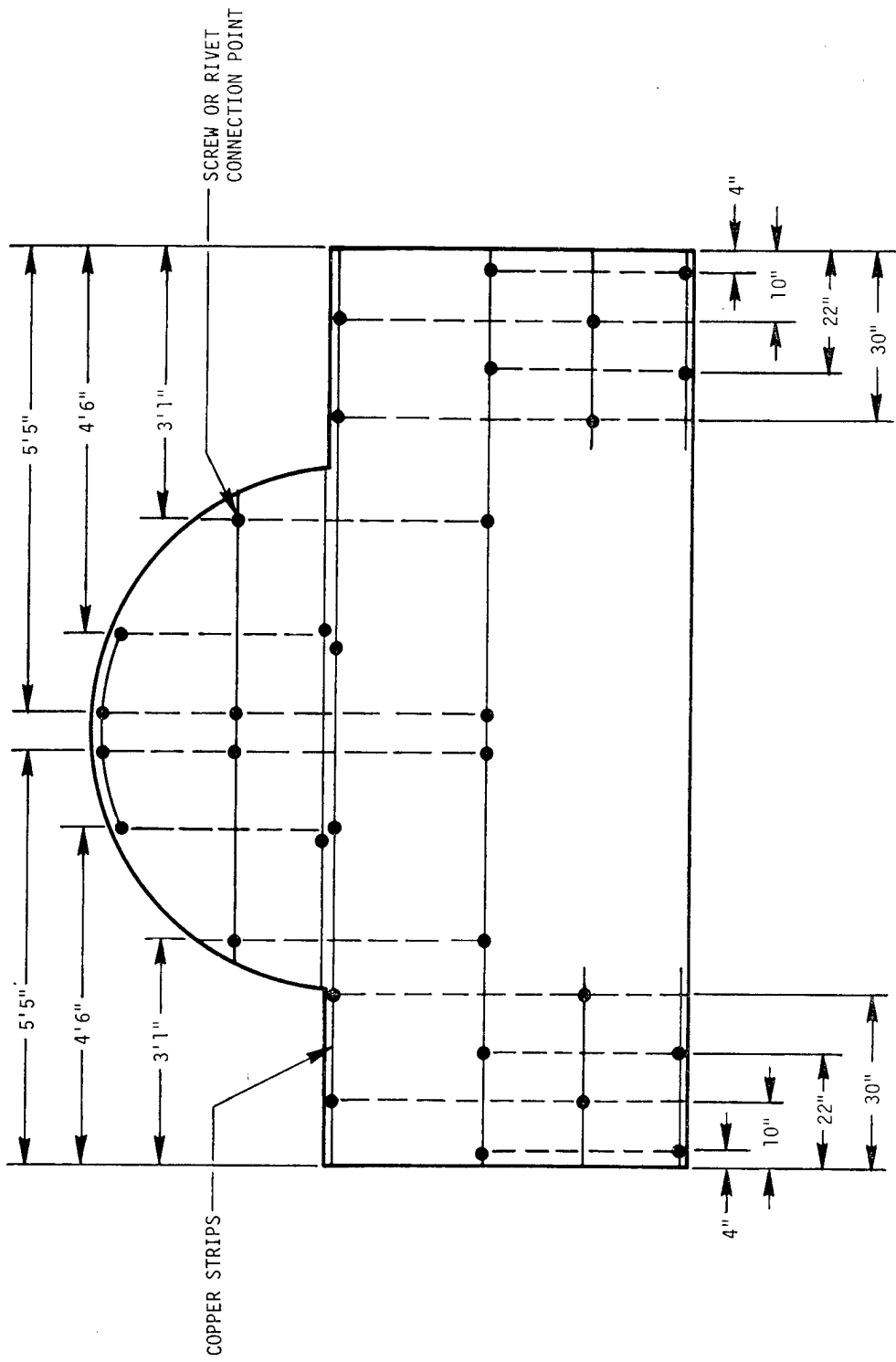

Figure IV-9. Frontal Target Screw Locations (Front Side)

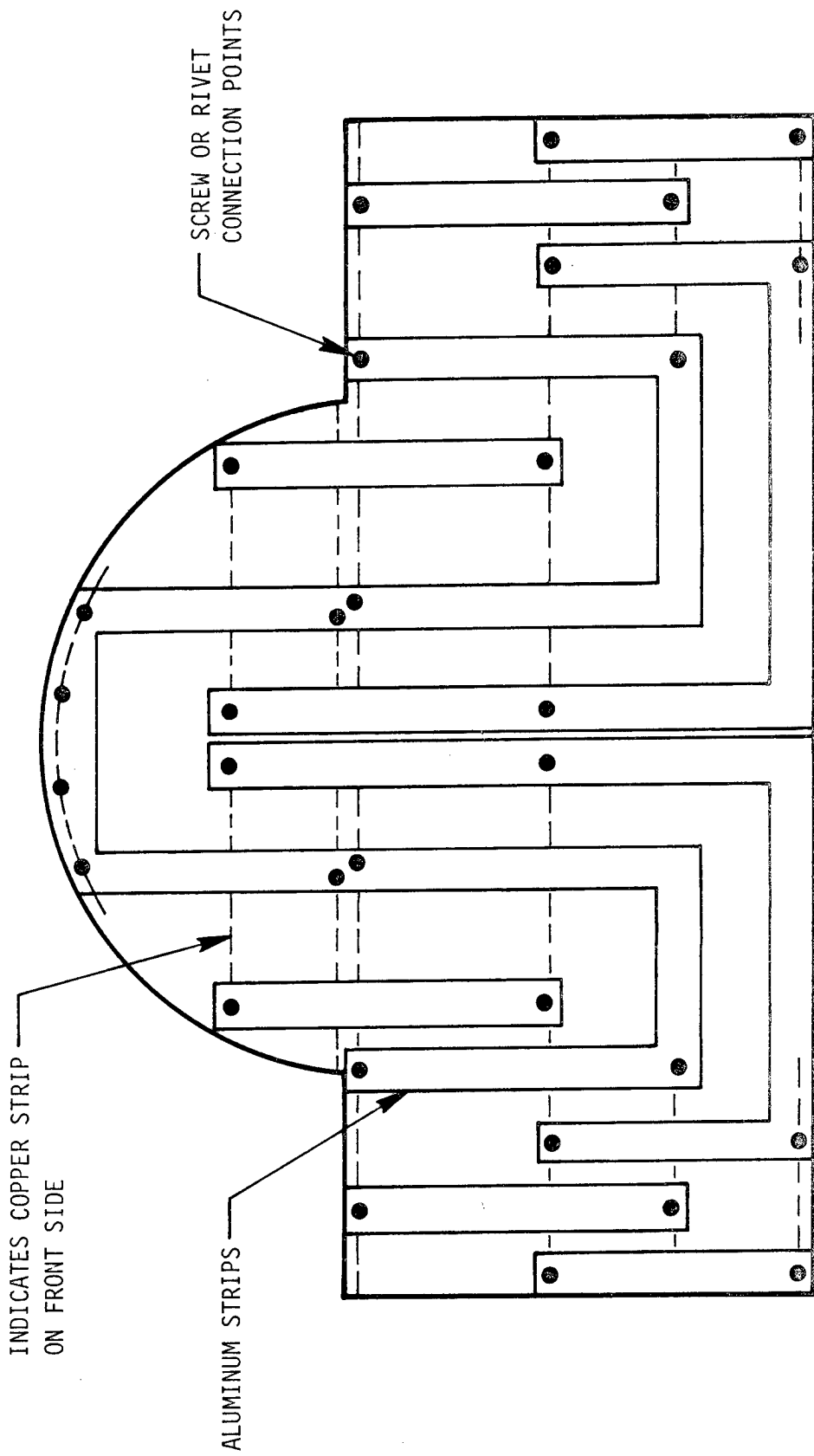

Figure IV-10. Frontal Target Aluminum Conductor Placement (Rear Side)

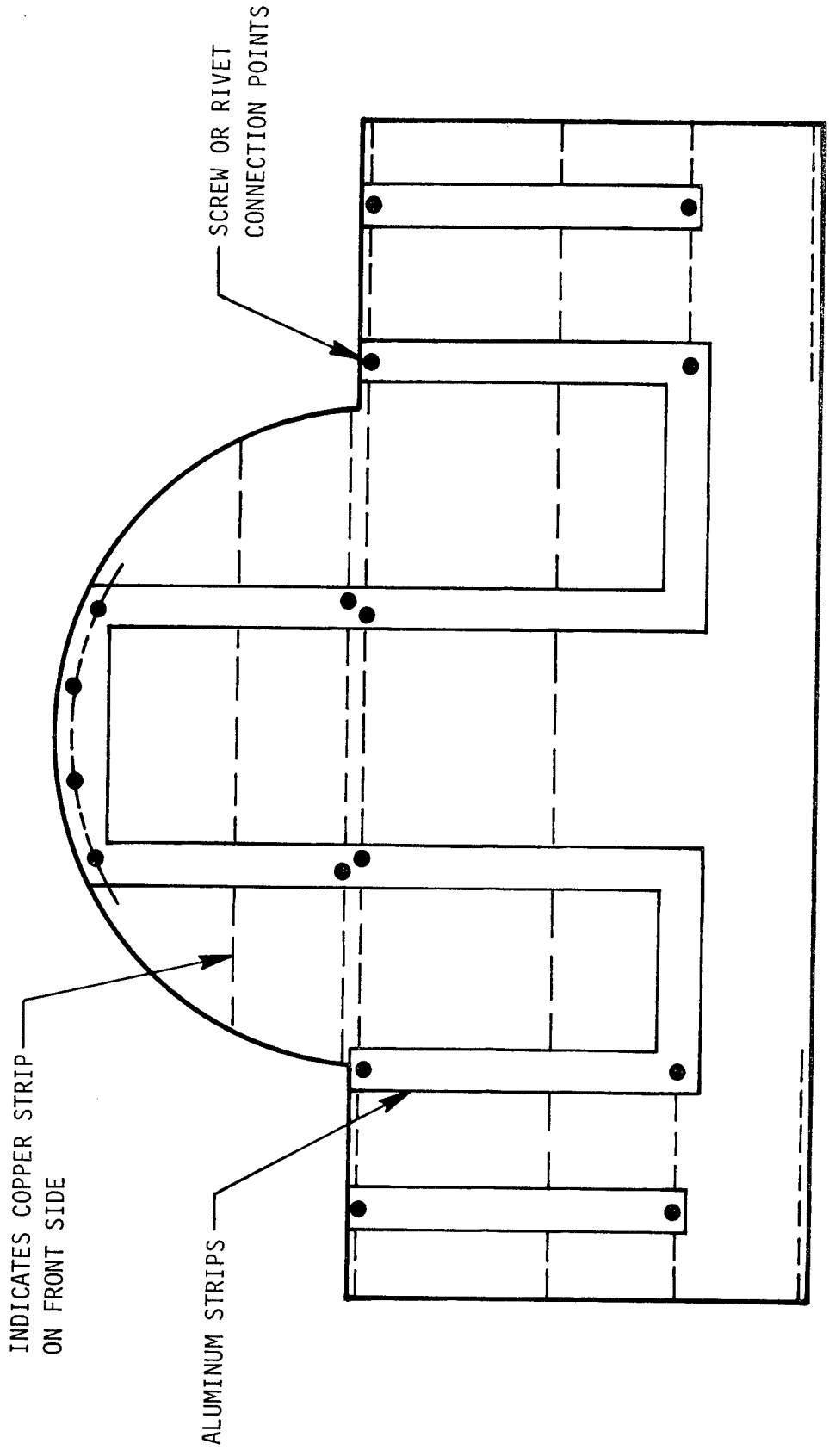

Figure IV-11. Frontal Target Negative Aluminum Conductor (Rear Side)

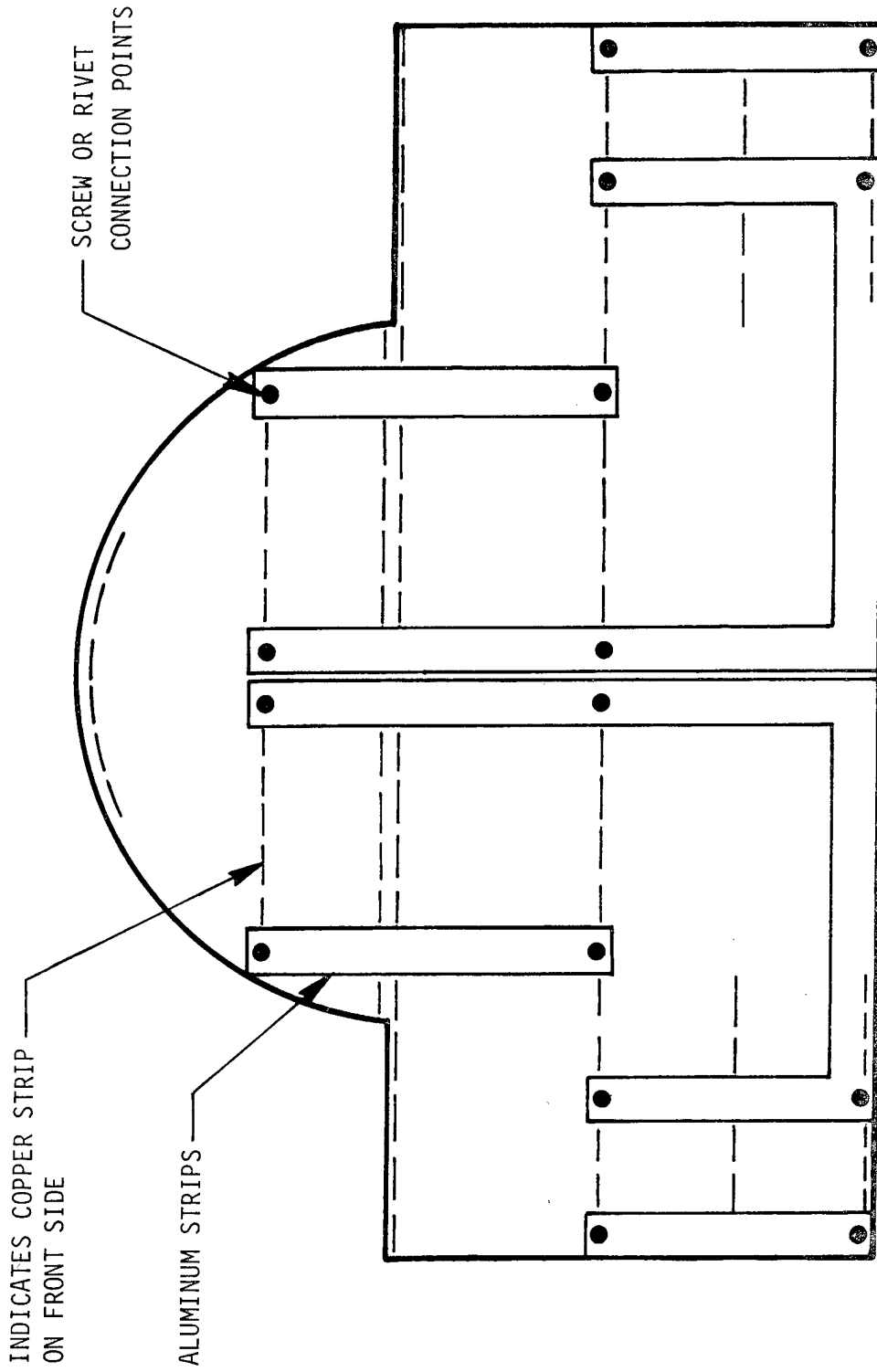

Figure IV-12. Frontal Target Positive Aluminum Conductor (Rear Side)

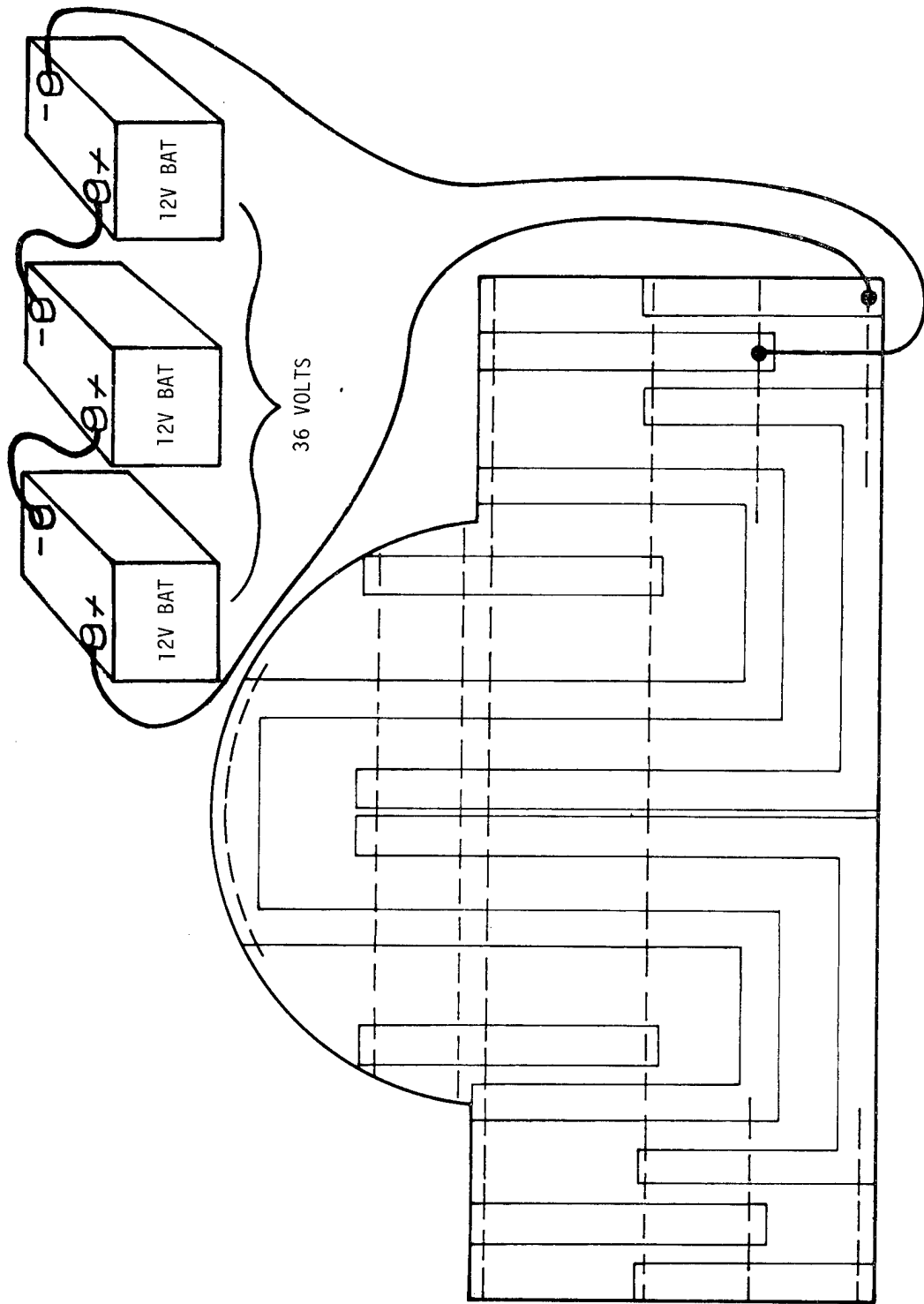

Figure IV-13. Frontal Target Battery Hookup (Rear Side)

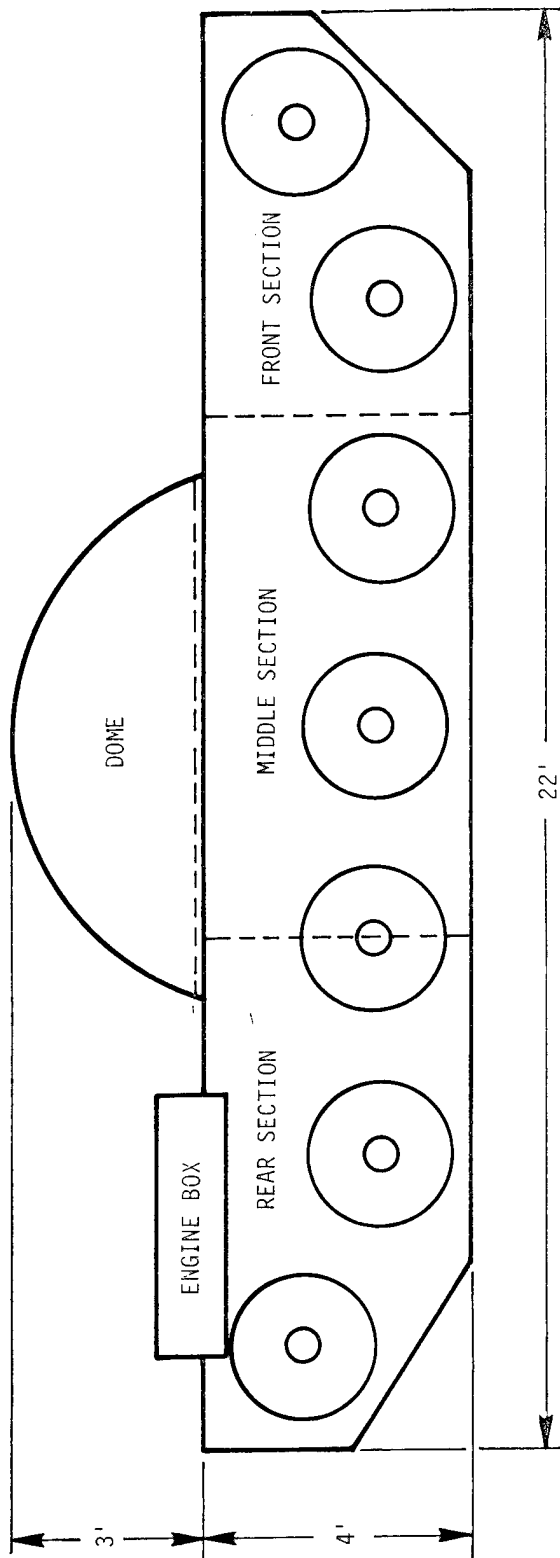

Figure IV-14. Flank Target Piece Assembly (Front Side)

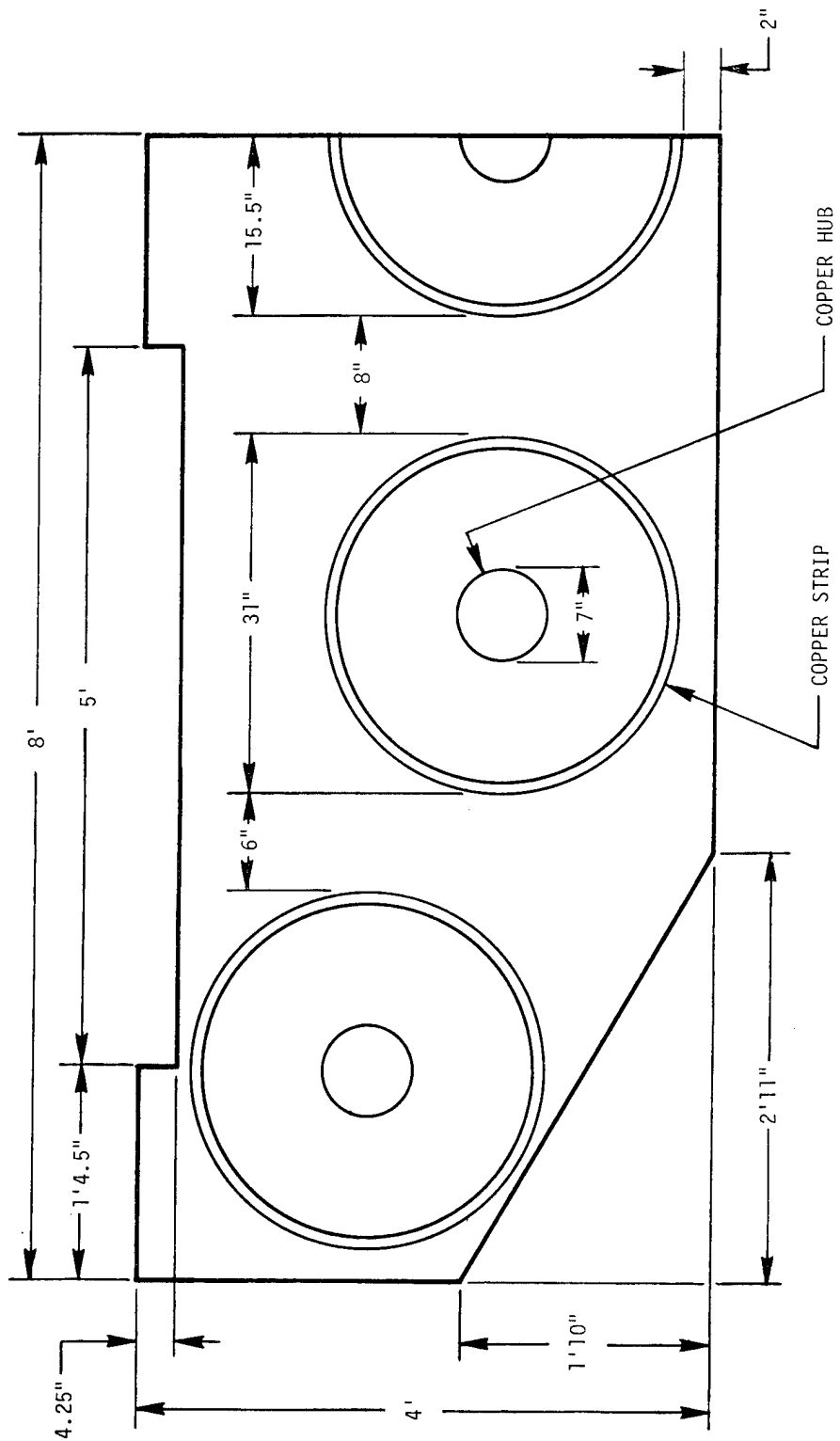

Figure IV-15. Flank Target Rear Section (Front Side)

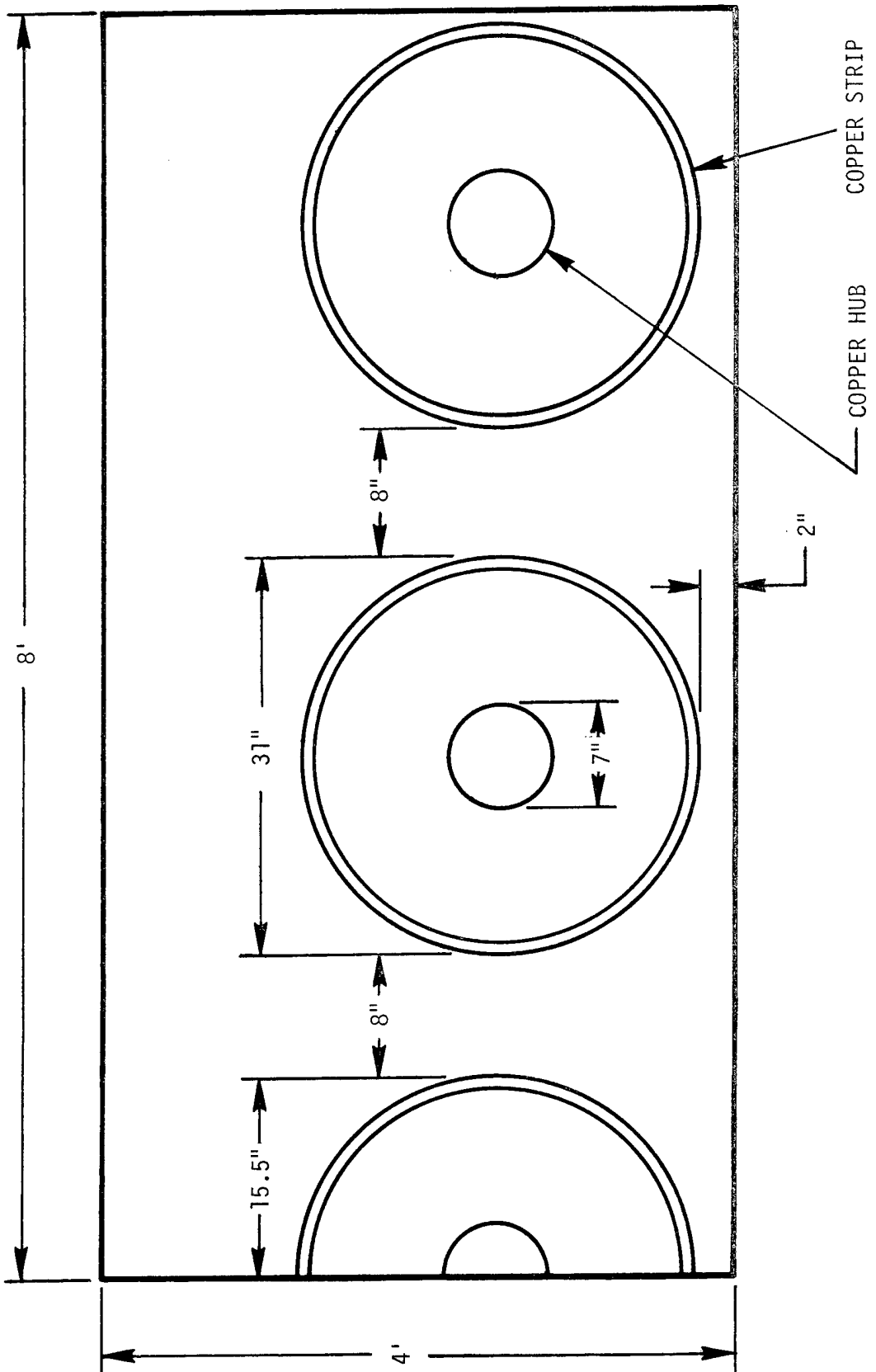

Figure IV-16. Flank Target Middle Section (Front Side)

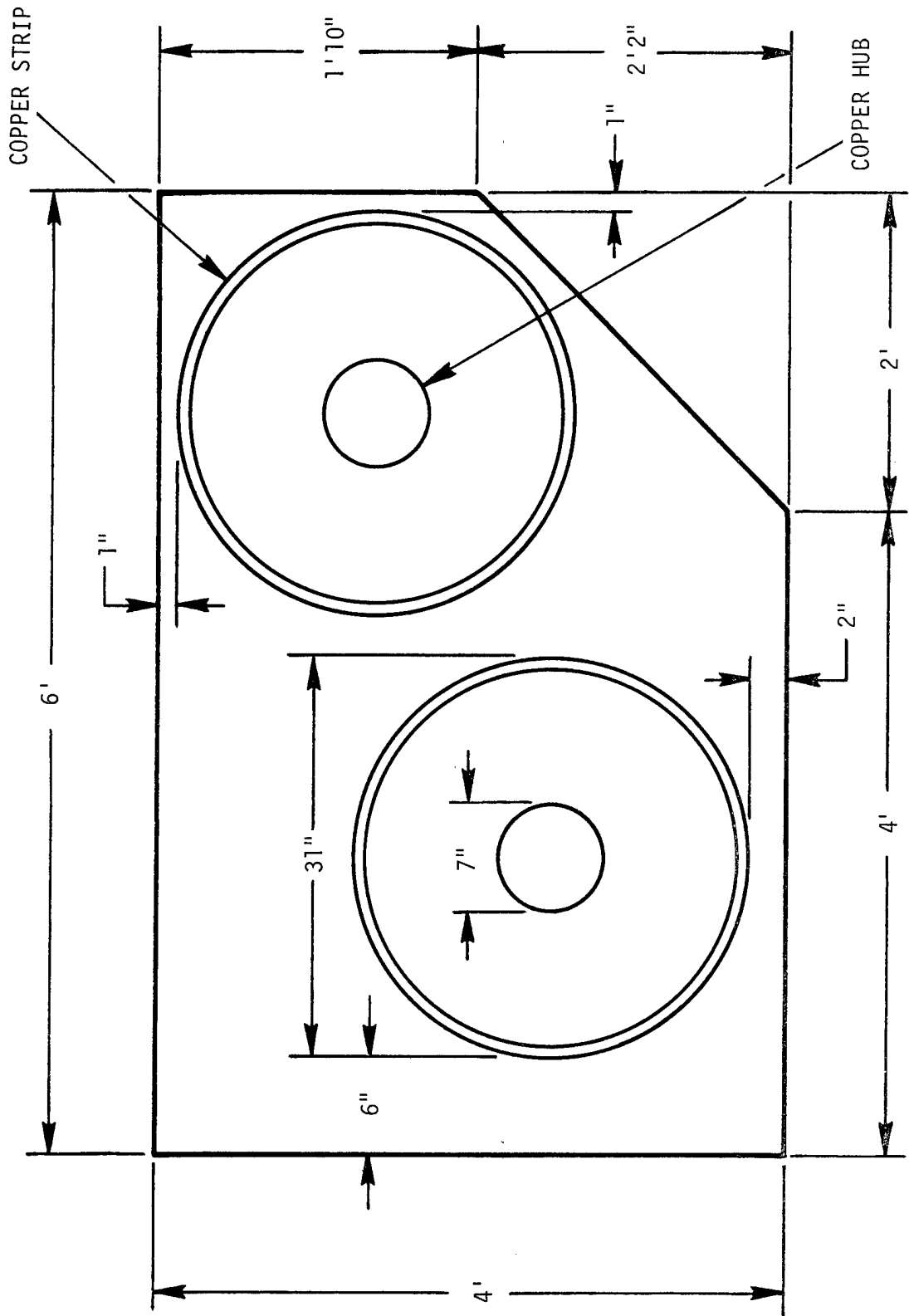

Figure IV-17. Flank Target Front Section (Front Side)

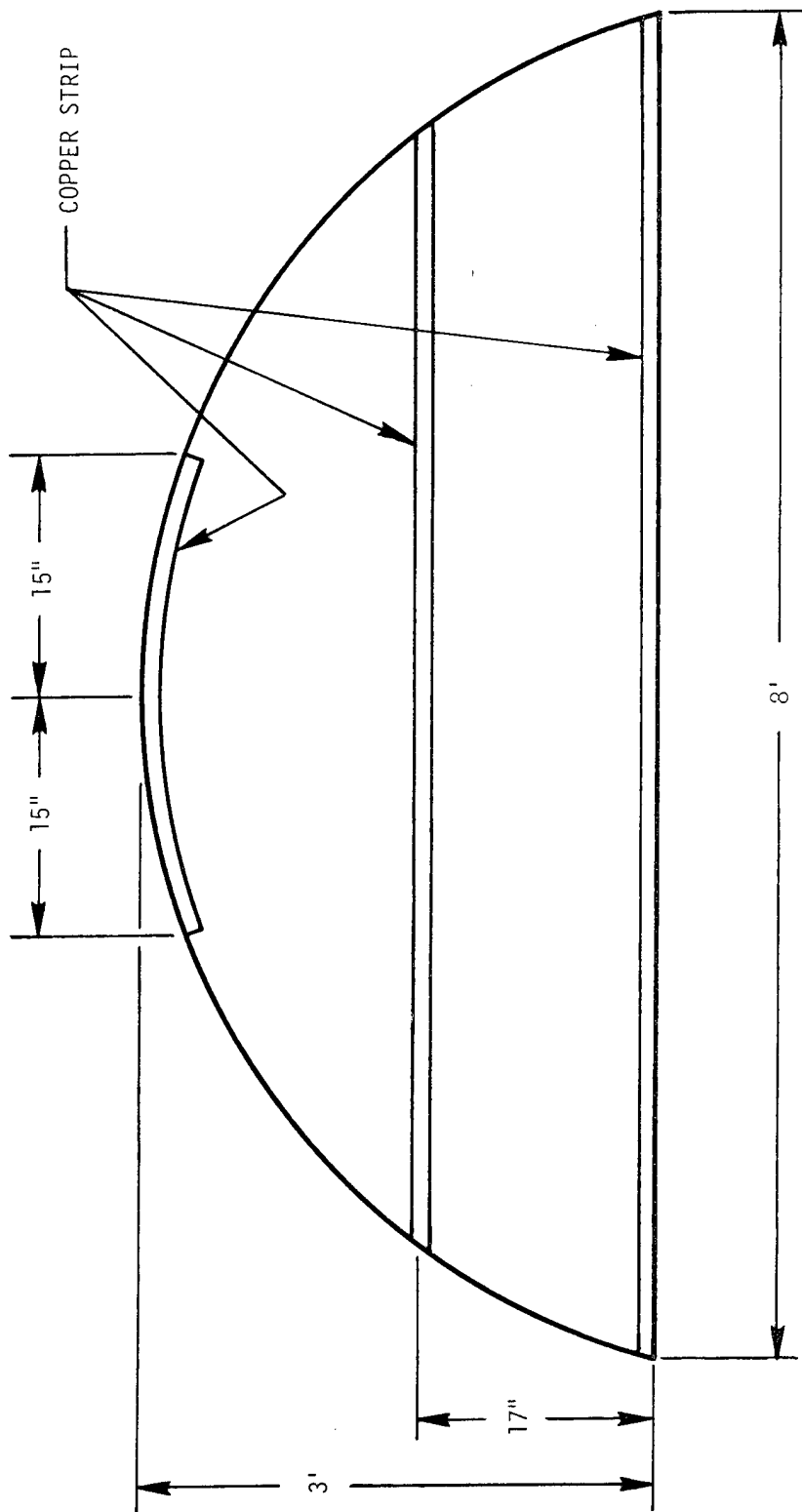
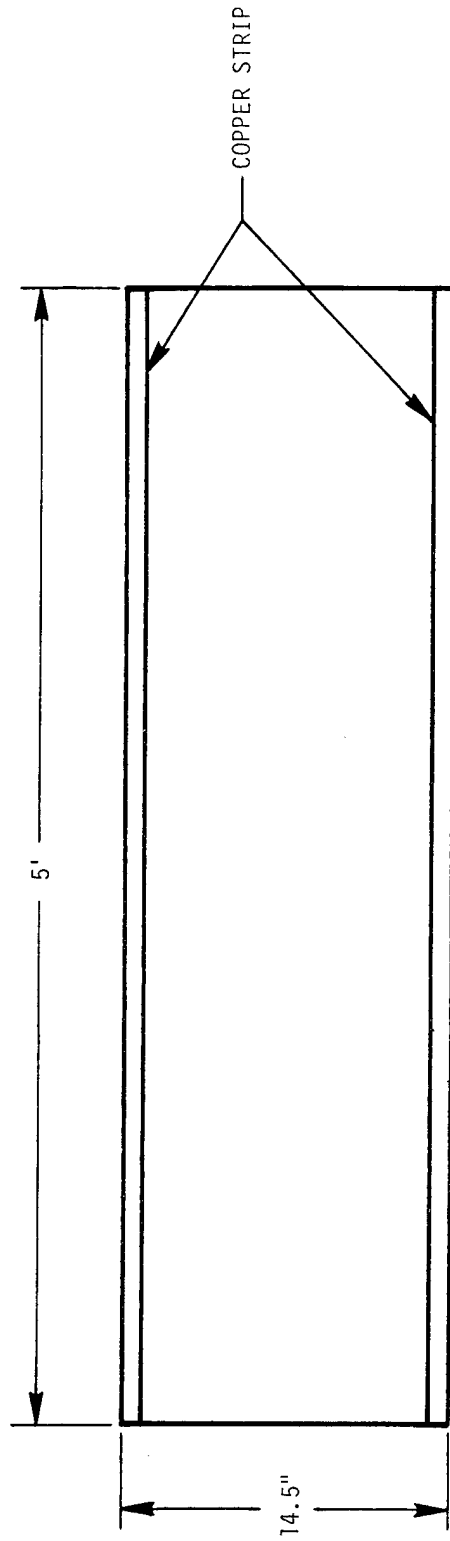

Figure IV-18. Flank Target Turret (Front Side)



IV-21

Figure IV-19. Flank Target Engine Box (Front Side)

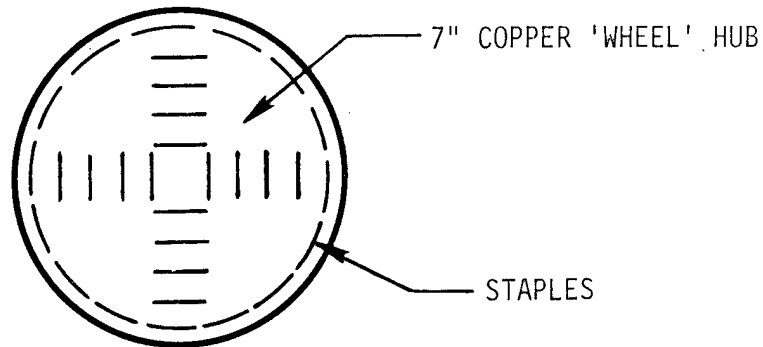

Figure IV-20. Wheel Hub Construction

6. Copper stripping ($\frac{1}{2}$ " wide, .002" thick) is now added to the outer rim of the Tensheet wheel. The copper stripping must be folded as it is formed to the circumference of the wheel. The folding reduces the tendency for the stripping to buckle and, therefore, produces an excellent electrical contact with the Tensheet. Figure IV-21 details this folding procedure. Figure IV-21(A) shows a profile view and figure IV-21(B) is a top view of the copper strip after it has been folded and before it has been pressed and subsequently stapled down to the Tensheet. Repeat this procedure for all wheels on the front, middle, and rear plywood target sections.

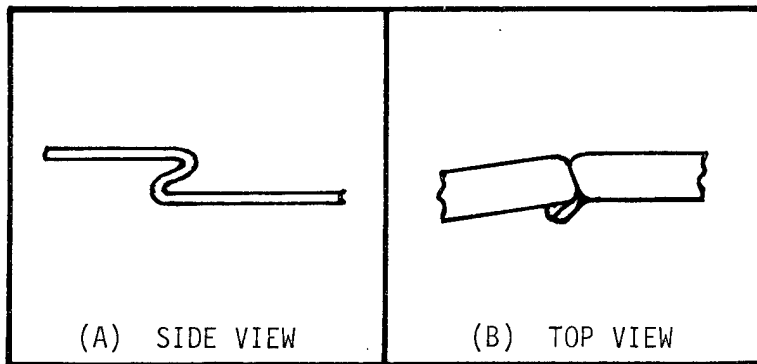

Figure IV-21. Folding of Copper Electrode to Form a Wheel Rim

The proper stapling pattern for the copper stripping is as shown in figure IV-22. Use 20 staples per foot along the copper stripping and the staples should be close to the edges of the strip.

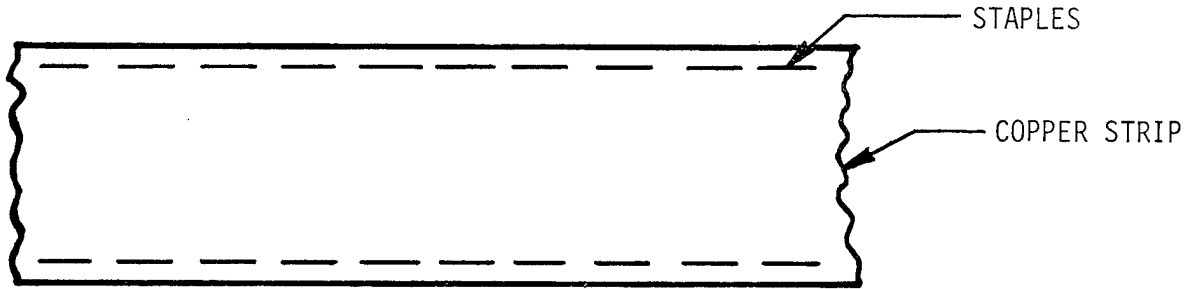

Figure IV-22. Stapling of Copper Electrode

7. Cover the bottom half of the dome (17" width) with a horizontal strip of Tensheet and tack in place -- see figure IV-18. Cover the top half of the dome (19" width) with another horizontal piece of Tensheet: pay special attention to matching the seam of the top and bottom half of the Tensheet to each other. Do not overlap! Tack the top half of the Tensheet in place.

8. Tack down copper stripping along the seam of the Tensheet top and bottom halves. Make sure that the copper strip covers both top and bottom pieces of Tensheet along the entire length of the seam. Staple down the copper strip with the top row of staples fastening the top piece of Tensheet and the bottom row of staples fastening the bottom piece of Tensheet.

9. Apply the top and bottom copper strips to the dome, according to figure IV-14, and staple down as shown in figure IV-22. To create the arc at the top of the dome, fold the copper stripping as shown in figure IV-21.

10. Cover the engine box with a lengthwise strip of Tensheet; see figure IV-19. Fasten the copper stripping to the top and bottom edges as shown.

11. Assemble the target frame according to figure IV-23. Use 8-penny nails to attach the 2-by-4 lumber frame pieces to themselves.

12. Lay the assembled target frame in a horizontal position with the two 16-foot pieces on the bottom, i.e., facing down. Next, lay the plywood target pieces on the frame and align as per figure IV-23. Secure the target pieces to the frame by using 4-penny nails.

NOTE: Space nails at least six inches vertically and two inches horizontally apart.

Avoid driving nails which will protrude through the bracing or target. If a nail is driven through an electrically active area on the front of the target and does protrude thru the rear bracing, there is a chance of an electrical short with the wiring on the back of the target. Therefore, any protruding nails should be replaced with shorter length nails.

13. Holes are now drilled from the front side of the target, through the copper stripping using a 5/32" drill bit. The approximate hole placement is shown on figure IV-24. The exact location of these holes may depend upon frame member placement.

14. Working from the back side, layout the aluminum tape following the pattern on figure IV-25, IV-26, and IV-27. When laying the aluminum tape over a 2-by-4 frame member, position the tape so that it follows the contour, i.e., run the tape up the side of the 2-by-4, across, and then down the other side.

15. Insert #6-32 machine screws, with washer on front and back; thread on the proper nut, and tighten securely. Repeat this for all connection points on the target.

NOTE: Remove all staples that are underneath the screw and washer. This will assure a good electrical connection.

16. Paint all screw heads, washers, copper stripping, and nail heads with SEC conductive paint. This is done to insure a good electrical contact of the copper stripping to the Temsheet. The painting strokes should be such as to draw the conductive paint under as well as over the edges of the copper stripping. This procedure is best performed with the target in a horizontal position.

NOTE: Frequent and thorough mixing of the SEC conductive paint is imperative to mix the carbon particles in the paint.

17. Paint all remaining exposed plywood on the front side of the target with any water-based flat-black paint.

18. Wrap the front side of the target with bubble plastic sheet. Wrap it around top and side edges of the target and staple it on the back side of the target. A 4' wide by 23' long piece of bubble plastic should be used for the 'body' portion of the target and a 8.5' by 3.5' piece should be used for the 'dome' of the target.

ELECTRICAL HOOKUP OF TARGET

The flank target requires 36 volts DC power supply. This may be obtained from three 12-volt batteries wired in series. Figure IV-28 shows a recommended hookup procedure.

Do not exceed 36 volts or three 12-volt batteries in series!

Before using the target, the following test must be performed. An ohmmeter must be attached to the completed target. This connection must be made at the same points that you will attach the battery. The resistance of a flank target will read between 1.5 and 5 ohms. When the resistance check has been made and the resistance is found to be satisfactory, then remove the ohmmeter and the target is complete.

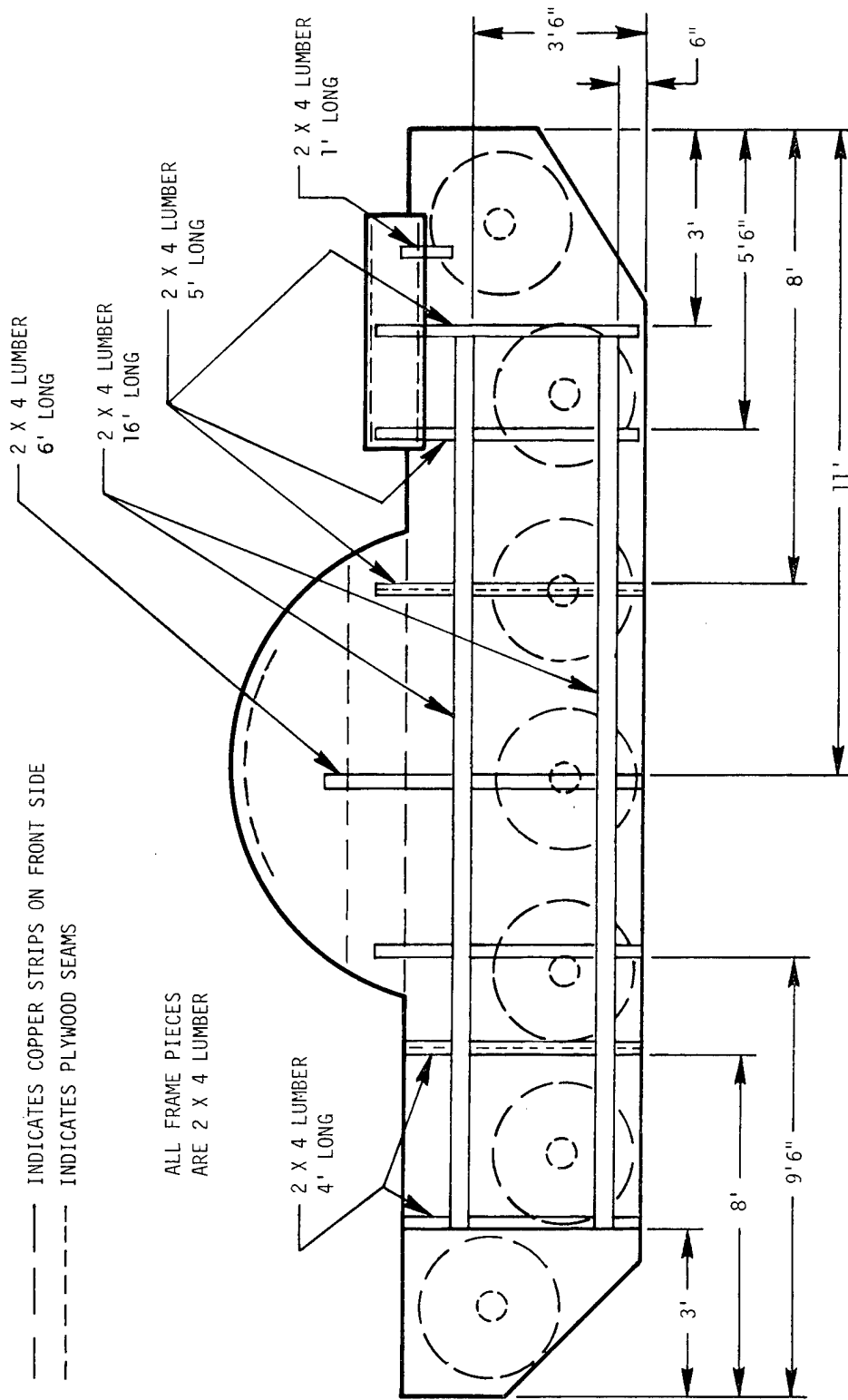

Figure IV-23. Flank Target Frame Specifications (Rear Side)

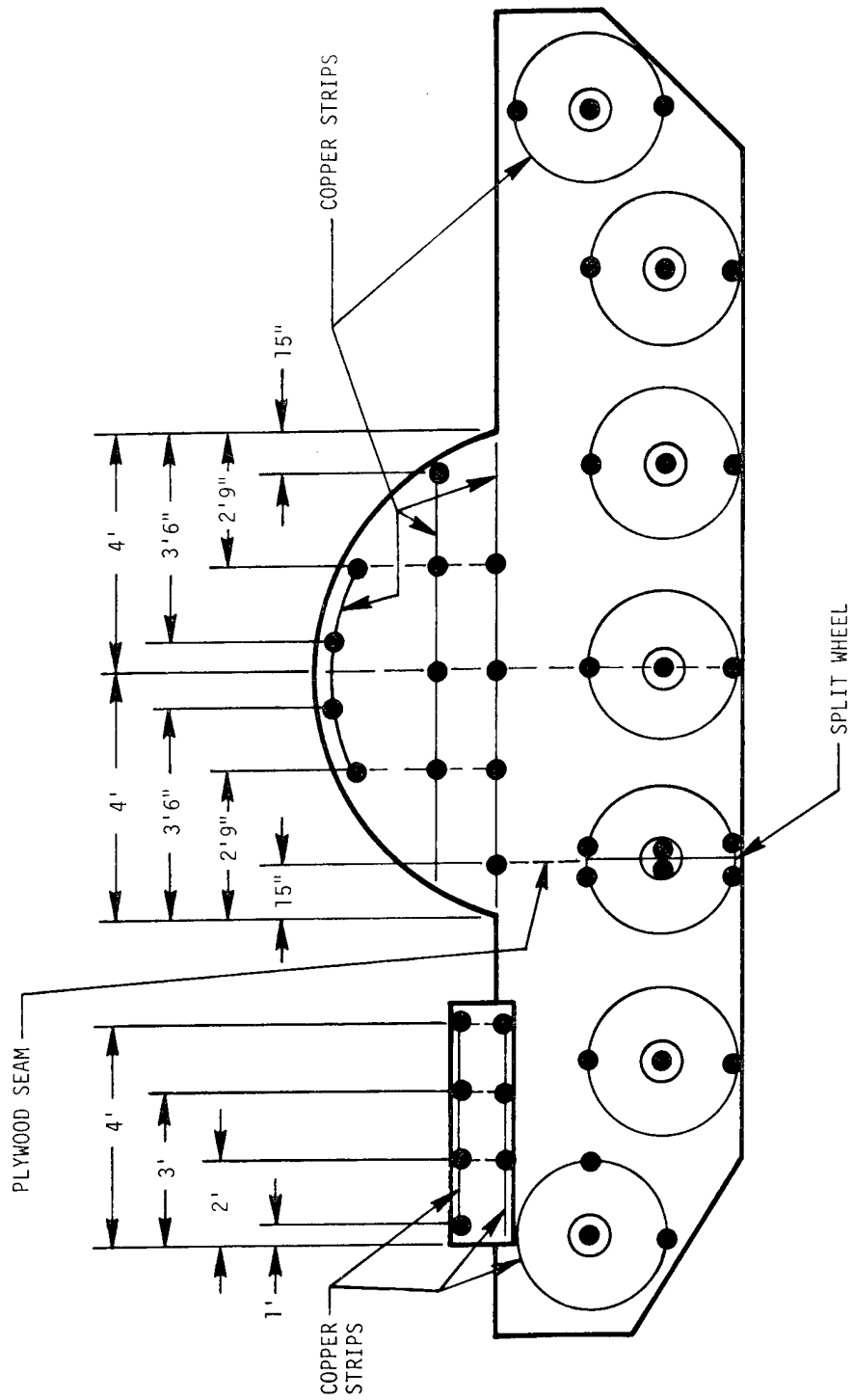

Figure IV-24. Flank Target Screw Locations (Front Side)

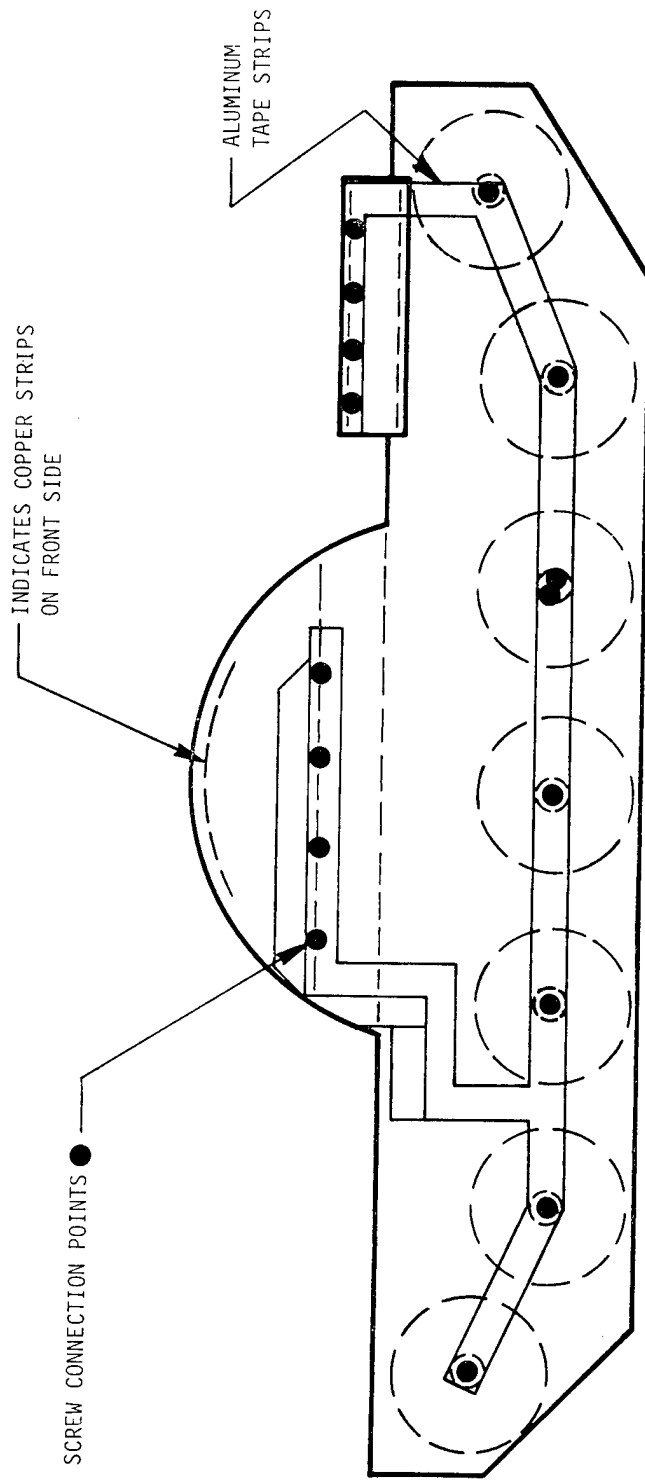

Figure IV-25. Flank Target Negative Aluminum Conductor (Rear Side)

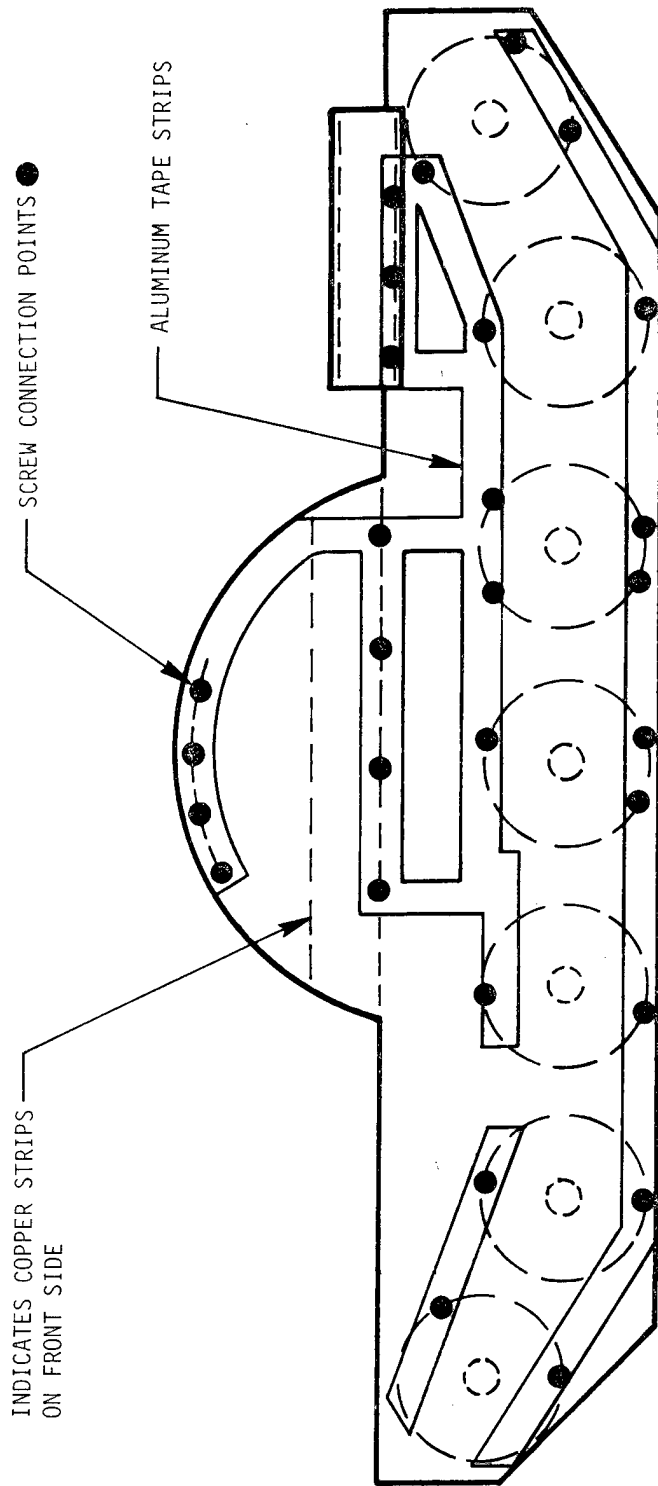

Figure IV-26. Flank Target Positive Aluminum Conductor (Rear Side)

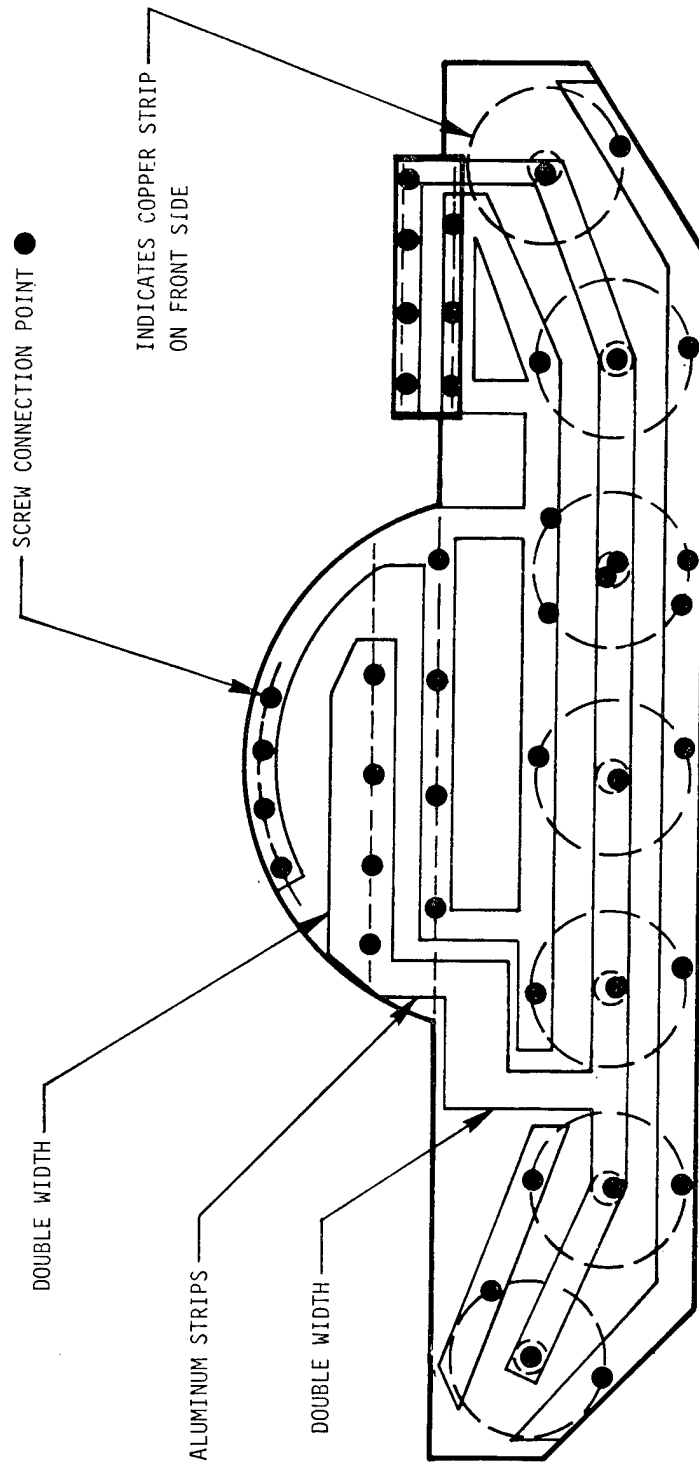

Figure IV-27. Flank Target Aluminum Conductor Placement (Rear Side)

SOME SPECIAL NOTES

The aluminum tape makes good electrical contact on the ungummed side only. The end of the tape must be folded over (gum inside) before a piece of tape may be attached (stapled) to another piece of tape.

Any or all painting with SEC conductive paint may be delayed until the target construction is nearly complete, as this will save time and paint.

Staples should be hammered down to insure good electrical connection between the Tensheet and the copper stripping.

Twenty-four volts (two batteries in series) may be used under some environmental conditions, i.e., low wind speeds, if the thermal signature is judged adequate by the user. In some cases, under sunny daytime conditions, no battery power may be necessary due to solar heating of the target.

REPAIR

Repairs to the thermal targets in the field can be approached two different ways. The target can simply be restored to operation by replacing the aluminum tape and/or copper stripping with patches of new aluminum and/or copper stripping, thus restoring electrical continuity to the target. The second method includes the previous repairs and in addition to this, the damaged Tensheet is patched, thereby producing a flawless thermal signature as when new. The repair of thermal targets has been divided into two basic approaches because Method 1 has proven to be 'adequate' in the field under our test conditions and Method 2 is a complete target repair method. Depending upon the results desired, either repair method is satisfactory.

METHOD 1

Repairing damaged aluminum tape with new tape is accomplished by using a short section of aluminum tape, with both ends folded over (gum inside), and stapling it over the damaged tape. Due to the sometimes severe damage afflicted to a target, it is wise for the repairman to be familiar with the wiring layout or for him to have a wiring diagram of the target. This precaution will help insure that the target will be rewired correctly.

Copper stripping on the front side of the target should be replaced in the same manner as the aluminum tape on the back. An area on either end of the damaged copper strip should be scraped clean of paint to insure a good electrical connection. A piece of copper stripping should have its ends folded over for strength and then the strip laid over the discontinuity and stapled down securely to the areas that were previously scraped clean.

An ohmmeter should be used as a final check on repair work done. Connect the meter to the screws which are being used for the wires from the batteries (do this only with the batteries disconnected). The ohmmeter should measure some finite value of resistance. The actual resistance will vary depending upon the number of 'hits' taken by the target. If the target is electrically shorted, then the resistance will read zero ohms and the target needs further inspection and corrective action must be taken to remove the short.

METHOD 2

Method 2 involves the same repair routine as in Method 1, however, Method 2 incorporates repairing the Tensheet areas as well. To repair the Tensheet first cut out a rectangular piece of Tensheet 'patch' material sized to cover the damage. Next staple the patch piece over the damaged Tensheet. The stapling should be done so as to keep the staples in a horizontal direction only. Also, staples should be no closer than one inch apart.

*****CAUTION*****CAUTION*****CAUTION*****CAUTION*****

The batteries must not be connected to a shorted target! Permanent damage will result to the batteries and there is a chance that the batteries will explode!

C. THERMAL SIGNATURE MAN TARGET CONSTRUCTION

1. Using an Army standard polyethylene man target, lightly sand both front and back sides to insure good paint adhesion.

2. Referring to figure IV-29, apply a 2" wide vertical strip of aluminum tape to the center of the target. This aluminum strip should start in the middle of the target, 4" from the bottom, and run vertically upwards to the top of the target, over the top and then down the back side of the target, just as on the front side.

3. Referring to figure IV-30, starting 4" from the bottom, fold a 2" wide vertical strip of aluminum tape along the right edge of the man target. The tape should be folded to provide half of the width of the aluminum tape on the front side and the other half of the width on the back side. Repeat this step for the left edge.

4. With the target in a horizontal position, paint the front side of the target with a coat of SEC conductive paint. The entire front side of the target should be painted, i.e., polyethylene and aluminum tape except the bottom 4" of the target; front and back. Allow four hours drying time and then apply a second coat and allow to dry. Turn the target over and repeat this procedure on the back side.

NOTE: Frequent and thorough mixing of the SEC conductive paint is imperative to mix the carbon particles in the paint. Be sure to loosen and mix completely all sediment on the bottom of the can.

5. Drill 5/32" holes in the location shown in figure IV-30. Scrape away the paint around the hole (front and back) and insert #6-32 machine screws with washer on front and back, thread on the proper nut, and tighten securely.

ELECTRICAL HOOKUP

6. Connect the two edge strips of aluminum tape to each other by a #12 gauge stranded wire between their respective screw connectors.

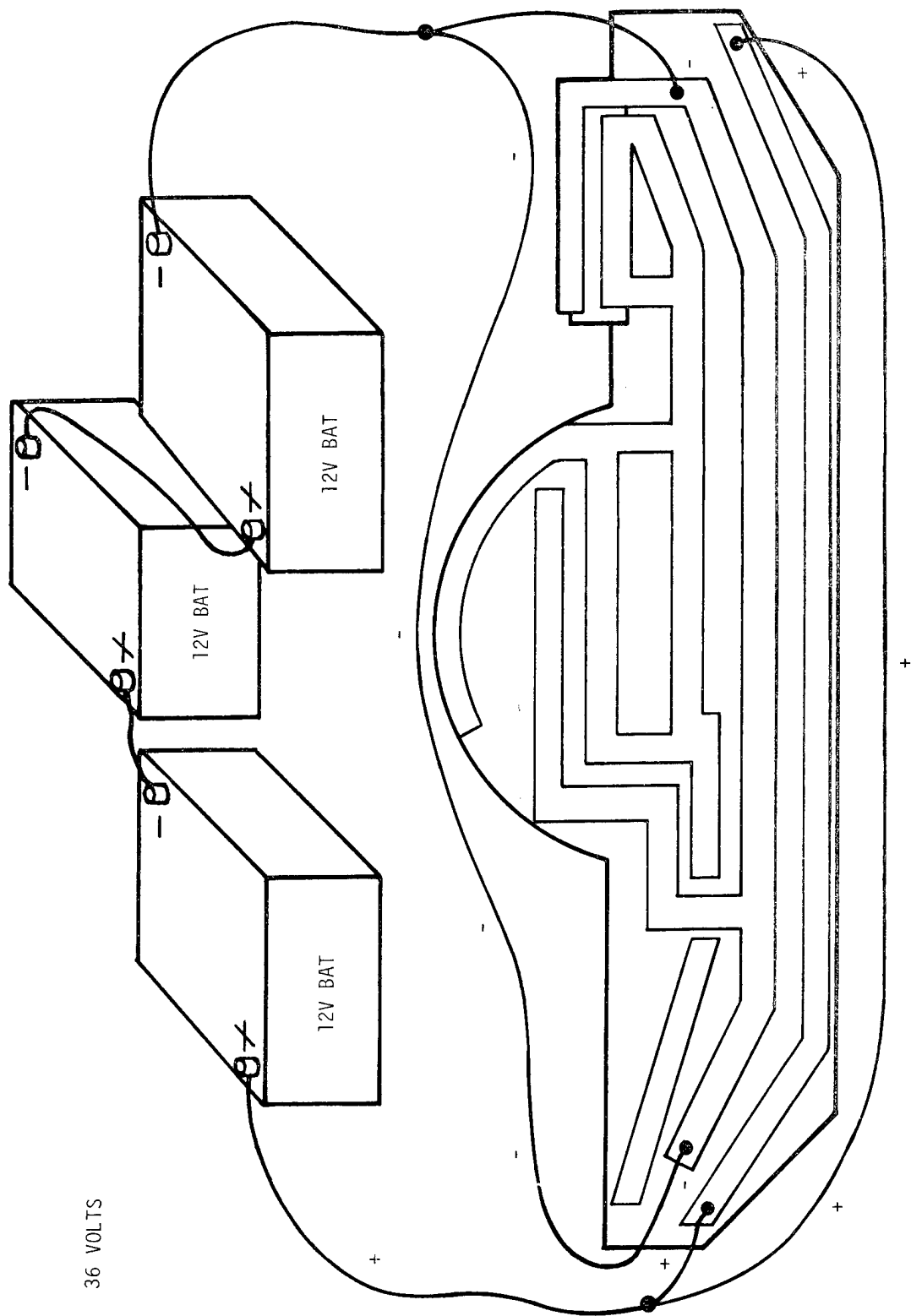

36 VOLTS

Figure IV-28. Flank Target Battery Hookup (Rear Side)

7. The man target requires 24-volt direct current (DC) power supply. This may be obtained from two 12-volt batteries wired in series. Figure IV-31 shows a recommended hookup procedure. Connect the positive battery lead to the screw on the center aluminum strip and the negative battery lead to either of the screws. This is illustrated in figure IV-31.

SOME SPECIAL NOTES

The aluminum tape makes good electrical contact on the ungummed side only. Therefore, do not attempt to patch together two pieces of aluminum tape when making a man thermal target.

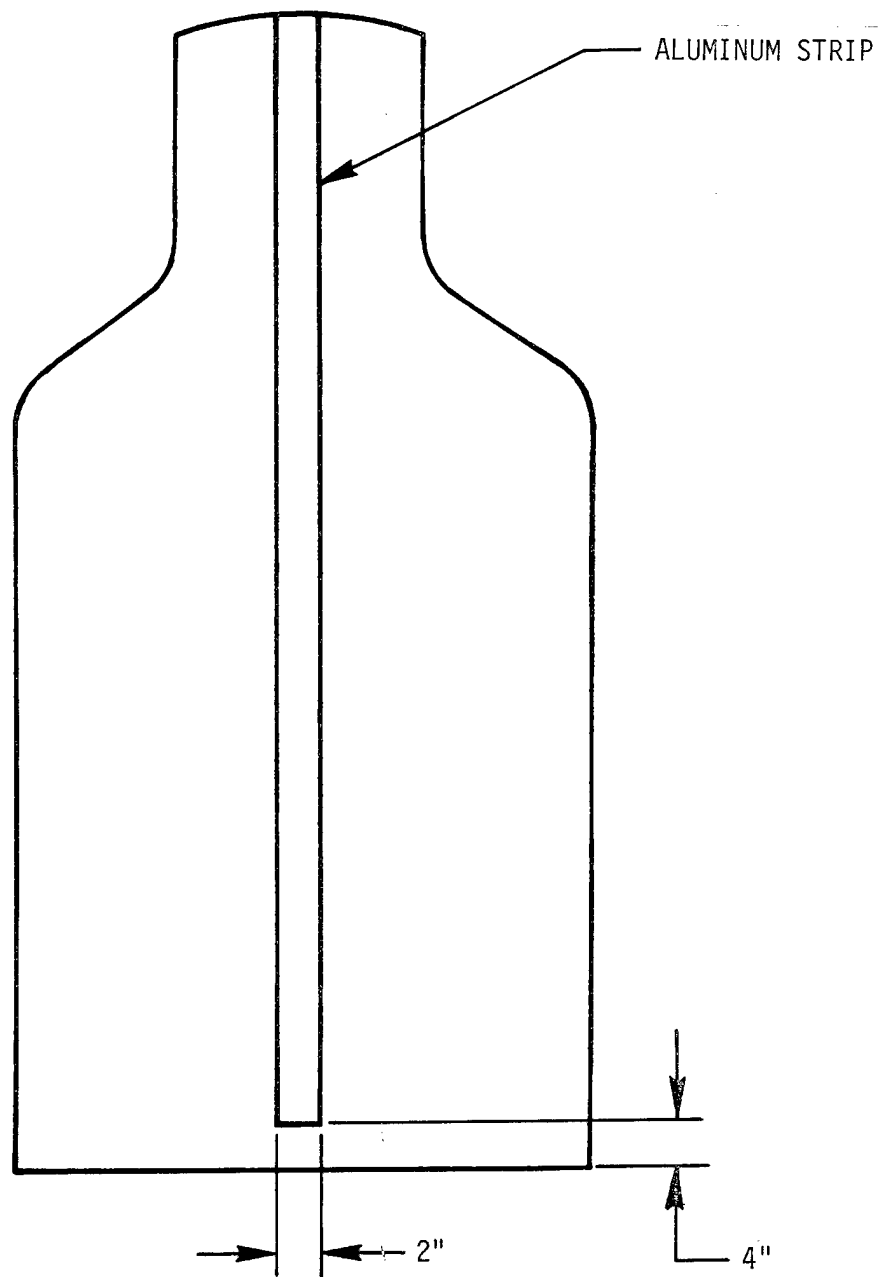

Figure IV-29. Man Target Center Conductor (Front Side)

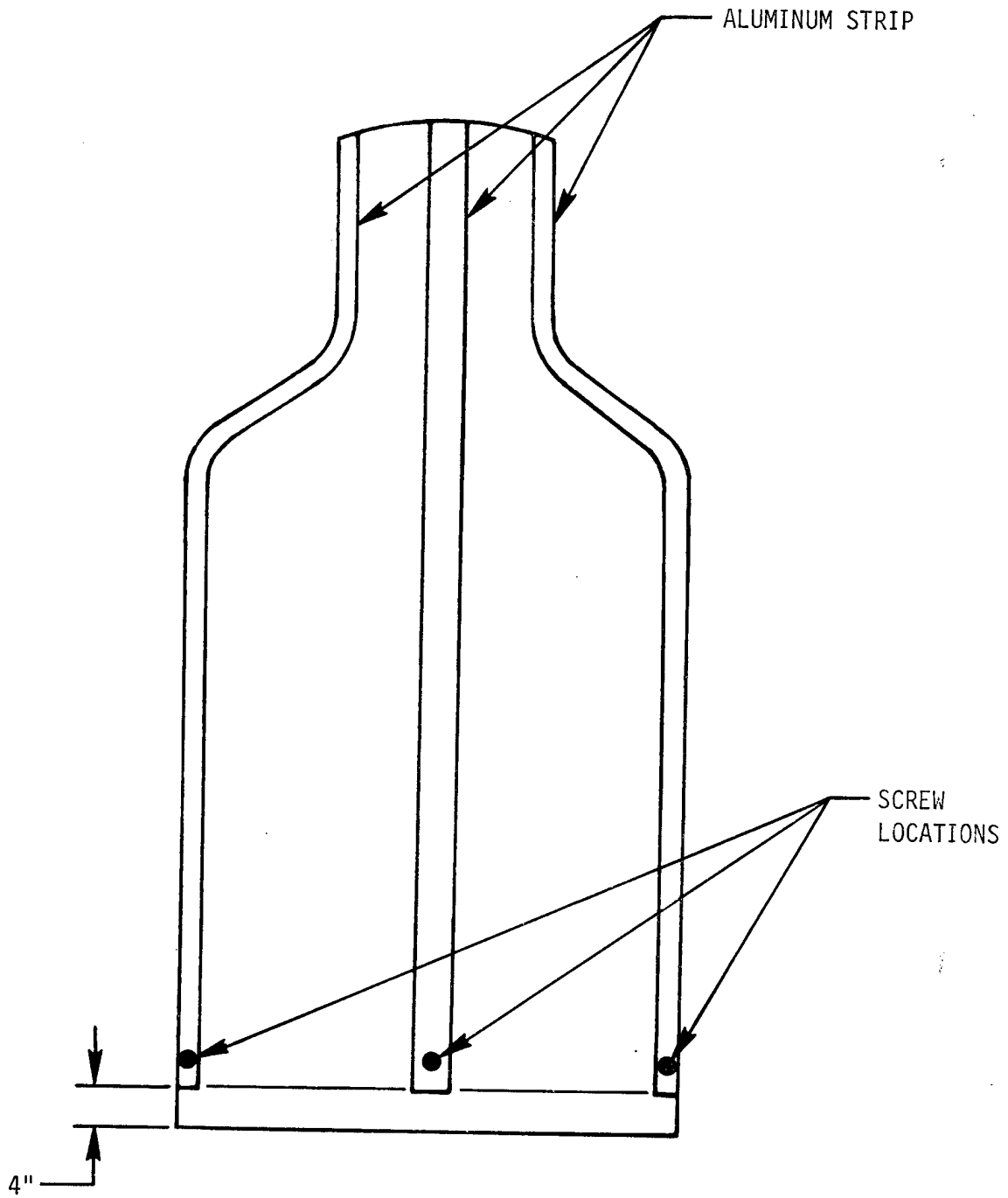

Figure IV-30. Man Target Center and Edge Conductors (Front Side)

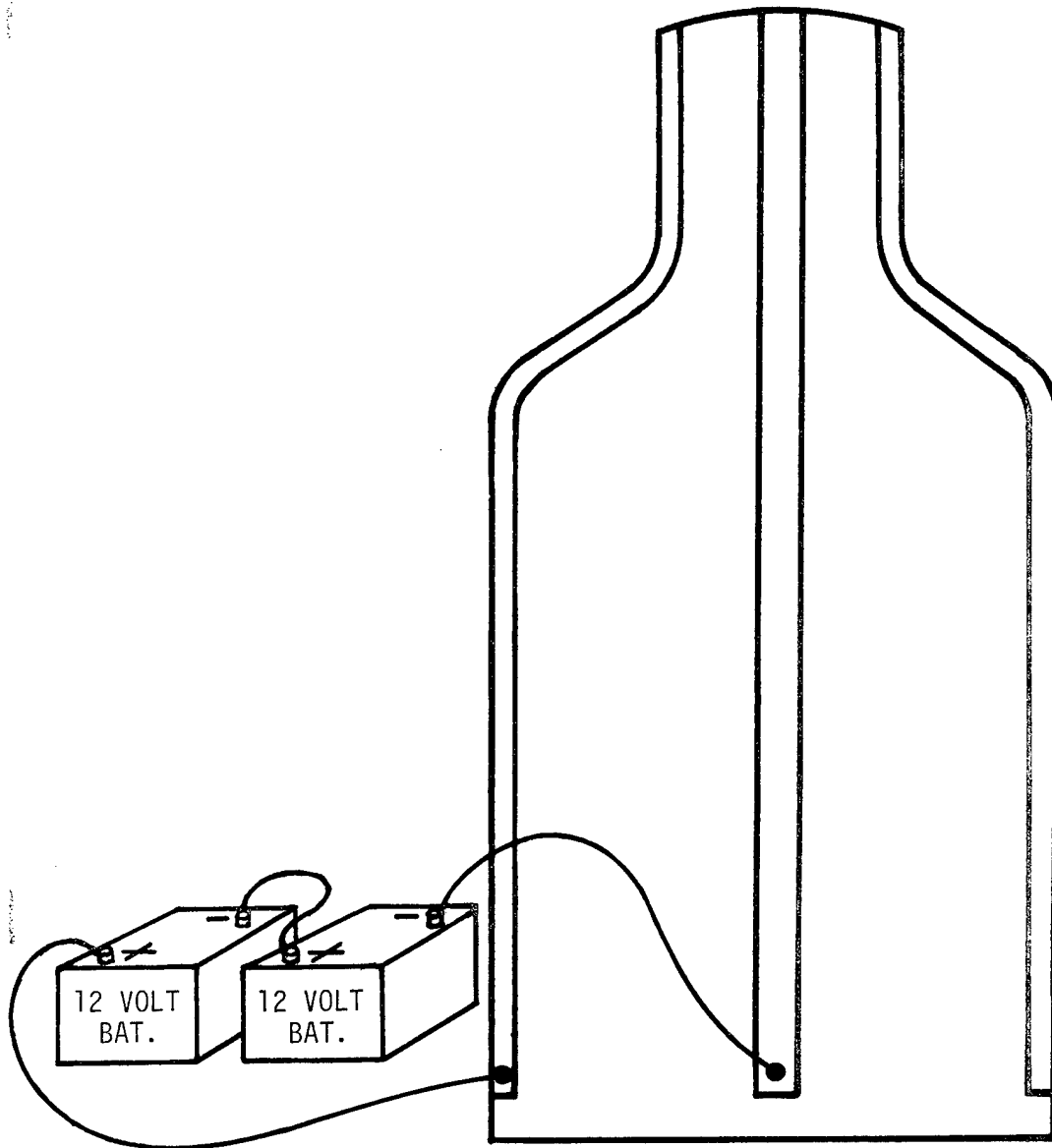

Figure IV-31. Man Target Battery Hookup (Rear Side)

SECTION V
TEST RESULTS

A. LABORATORY TESTING

Both scaled target models and full-scale targets were constructed and measured in the laboratory. Temperature measurements and thermal sight measurements, using a Hughes sight, were made in the laboratory to evaluate the targets prior to constructing other identical targets for live-fire tests at Ft. Knox.

Figure V-1 thru V-4 show temperature measurements made on both paint and Tensheet targets.

Figure V-1 is a frontal (Tensheet) target. Note that by proper electrode placement, the tracks are the hottest areas, followed by the turret area. The resistance of this target was 2.2 ohms. Using 39 volts, temperature differentials as high as 25° F were achieved in the tank tread areas.

Figure V-2 is a frontal (paint) target. The electrode placement is the same for both targets; however, the heating surface is paint versus Tensheet. The paint has a higher resistance, 10.6 ohms; therefore, to achieve equivalent temperature rises a higher voltage, i.e., 110 volts was necessary.

While equivalent thermal images resulted, some distinct disadvantages occurred:

1. The higher voltages required for paint targets require personnel safety precautions.
2. The 110 volts required to power a paint target cannot be provided by reasonable battery sources.
3. Small cracks were noted to appear in the paint surface as a result of weathering. The higher voltage for paint targets can cause sparking across these cracks and present a potential fire hazard.
4. Paint targets are more time-consuming to construct.
5. It is difficult to obtain a uniform coating using paint.

Figures V-3 and V-4 show temperature profile data for flank targets using Tensheet and paint targets. Note that the highest temperatures occur in the area where the tank engine is located. The next highest temperatures occur on the wheels followed by the turret.

A thermal sight detects the radiated power from a target. The convected power is loss that must be minimized. This was accomplished using a cellular plastic film ordinarily used in packing shipping containers. This plastic is inexpensive and causes only a small loss to the radiated power that passes through it. The air bubbles contained in the plastic material act as a good insulator to the convected power and tend to minimize this loss.

SCALE: FULL
 MATERIAL: TEMSHEET
 COVERING: NONE

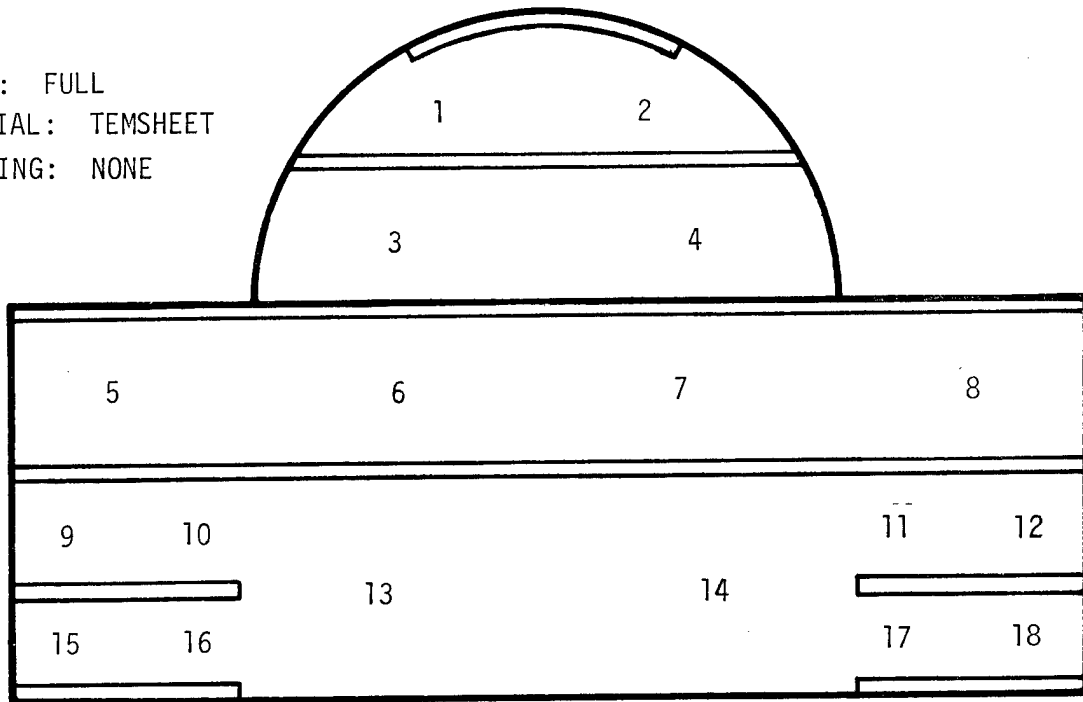

DATE: 8-8-77
 TIME: 1455
 LOCATION: MACHINE SHOP (INSIDE)
 POWER AC
 VOLTAGE: 39V
 CURRENT: 17.5A
 AMBIENT TEMP: 76.3°F
 WIND: NONE
 MODEL RESISTANCE: 2.2Ω
 COMMENTS:

TARGET TEMPERATURE: °F

#1 85.3°	#10 95.9°
#2 86.1°	#11 100.7°
#3 88.0°	#12 97.2°
#4 87.1°	#13 79.7°
#5 87.6°	#14 80.5°
#6 85.7°	#15 94.4°
#7 85.6°	#16 93.9°
#8 86.5°	#17 97.0°
#9 95.3°	#18 95.6°

NO'S INDICATE MEASUREMENT LOCATIONS

Figure Y-1. Temperature Measurement on Frontal Temsheet Target
 V-2

SCALE: FULL
 MATERIAL: PAINT *
 COVERING: NONE

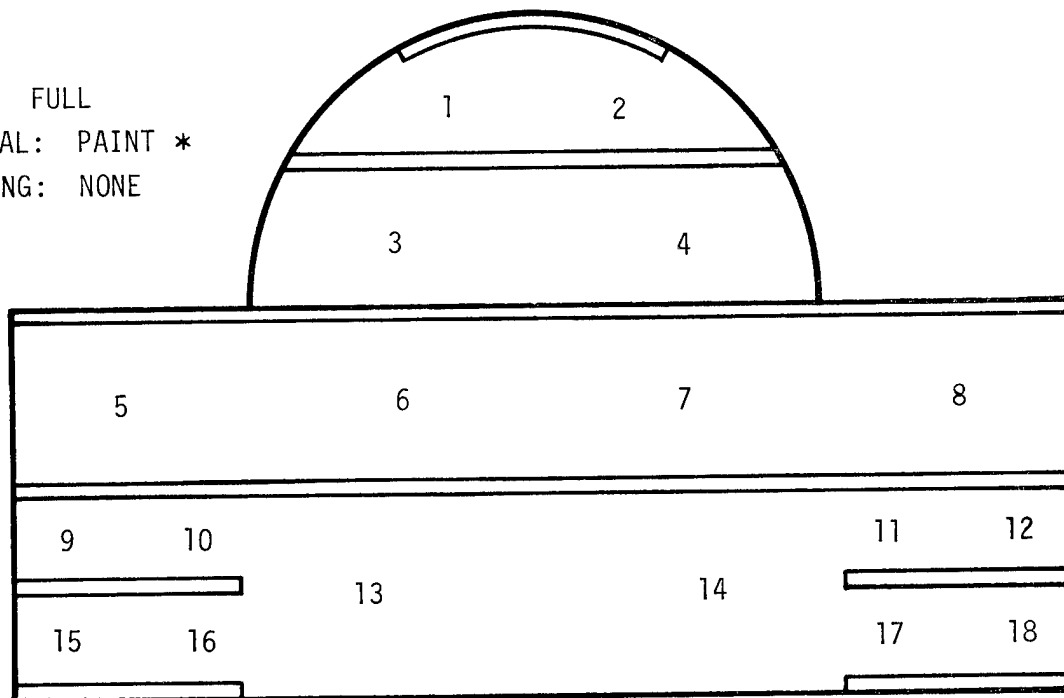

DATE: 8-9-77
 TIME: 1500
 LOCATION: MACHINE SHOP (INSIDE)
 POWER AC
 VOLTAGE: 110V
 CURRENT: 10.4A
 AMBIENT TEMP: 76.2°
 WIND: NONE
 MODEL RESISTANCE: 10.6 Ω
 COMMENTS:

TARGET TEMPERTURE: °F	
#1 93.4°	#10 108.9°
#2 93.7°	#11 106.9°
#3 99.6°	#12 106.9°
#4 99.3°	#13 78.8°
#5 97.1°	#14 78.6°
#6 96.7°	#15 108.7°
#7 95.5°	#16 108.9°
#8 96.2°	#17 105.8°
#9 110.4°	#18 105.9°

*PAINT - 2 COATS

NO'S INDICATE MEASUREMENT LOCATIONS

Figure V-2. Temperature Measurement on Frontal Paint Target

SCALE: FULL

MATERIAL: TEMSHEET
COVERING: NONE

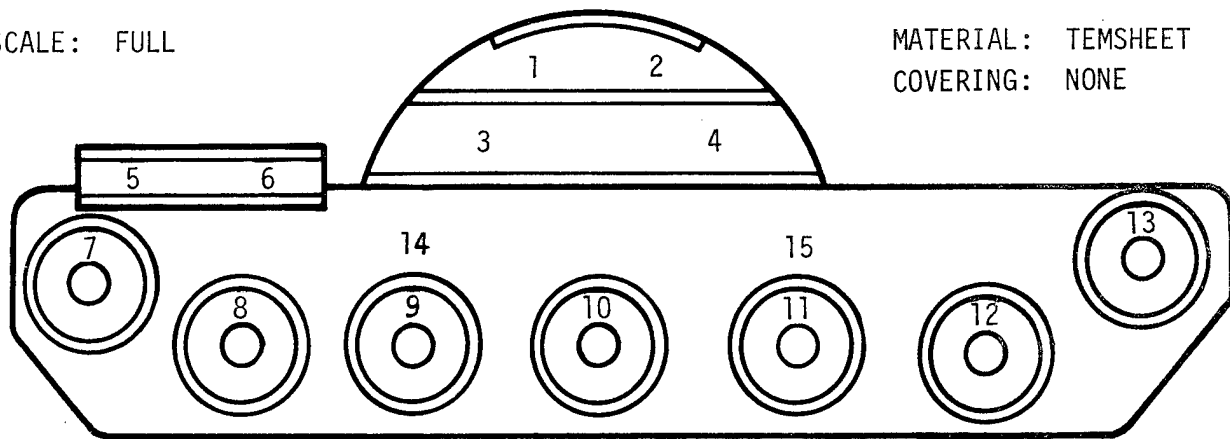

DATE: 8-8-77

TIME: 1000

LOCATION: MACHINE SHOP (INSIDE)

POWER AC

VOLTAGE: 38.8V

CURRENT: 23.2A

AMBIENT TEMP: 78.8°F

WIND: NONE

MODEL RESISTANCE: 1.672 Ω

COMMENTS:

TARGET TEMPERATURE: °F

#1	85.9°	#9	87.0°
#2	86.3°	#10	86.7°
#3	87.3°	#11	87.1°
#4	87.6°	#12	87.7°
#5	91.3°	#13	86.2°
#6	92.0°	#14	81.4°
#7	86.7°	#15	80.3°
#8	86.6°		

NO'S INDICATE MEASUREMENT LOCATIONS

$R_{cold} = 1.728 \Omega$

$R_{steady} = 1.672 \Omega$

Figure V-3. Temperature Measurement on Flank Temsheet Target

SCALE: FULL

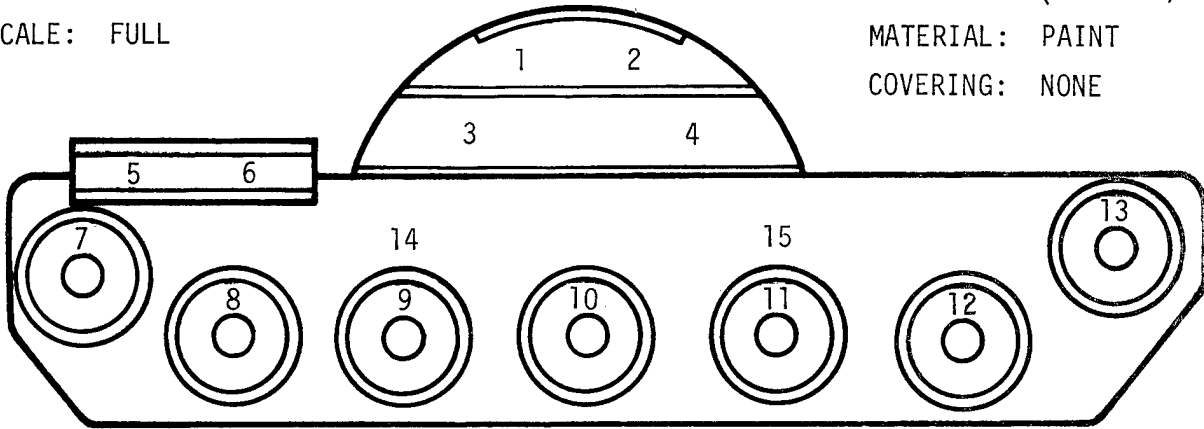

(2 COATS)*

MATERIAL: PAINT

COVERING: NONE

DATE: 8-10-77

TIME: 1535

LOCATION: MACHINE SHOP (INSIDE)

POWER AC

VOLTAGE: 109V

CURRENT: 11.5A

AMBIENT TEMP: 81.6°F

WIND: NONE

MODEL RESISTANCE: 9.478 Ω

TARGET TEMPERATURE: °F

#1 90.4° #9 95.6°

#2 90.2° #10 95.2°

#3 90.2° #11 96.6°

#4 90.0° #12 95.1°

#5 97.5° #13 95.3°

#6 97.7° #14 84.9°

#7 95.0° #15 84.8°

#8 95.4°

NO'S INDICATE MEASUREMENT LOCATIONS

Figure V-4. Temperature Measurement on Flank Paint Target

To illustrate the effects, we covered only the right side of a one-third scale model target with the cellular plastic. Photographs were then taken thru the thermal sight and are shown in figures V-5 through V-10. Figure V-5 is a flank view with zero wind. Figure V-6 is a flank view with 17 mph wind and figure V-7 illustrates 25 mph winds.

Winds were simulated using several fans.

Figure V-8 thru V-10 demonstrate the effects of the cellular plastic insulation on a frontal target. Data was taken with the Hughes thermal sight.

During August 1977, four full scale targets were built in Orlando and tested outdoors. Targets were constructed of both paint and Tensheet (figure V-11).

Flank and frontal targets were made of each kind of material. Figures V-12 and V-13 illustrate the data. Photos taken thru the sight do not fully achieve the same thermal image quality seen by the human eye, thru the sight.

Figure V-14 is a photo of a human target and the man target.

B. FIELD TESTING

During the week of 17 October 1977, live-fire testing was conducted at Ft. Knox on the Baum/St. Vith Range. Eight full-scale targets were constructed at Ft. Knox, using both SEC latex paint and Tensheet.

Major T. Sanford, Jr., US Army Armor and Engineer Board, Board Project Officer for the M60/A3 Thermal Sight System; Captain John Craddock, US Army Armor and Engineer Board, Deputy Project Officer for Thermal Sight System; and LTC Norman Porter, Assistant Test Manager, Armor, US Army, OTEA, witnessed the test firing. Major Sanford and Captain Craddock were asked for their opinion on the suitability of the thermal signature targets. Both officers stated that they were highly pleased with the thermal signatures. They felt that the signatures were realistic and the targets offered an excellent training device. LTC Porter thought the signatures were incredibly accurate and highly believable.

Video tapes of the firing were taken by the USAARENBD, test engineer, Mr. David C. Holliday. Copies are in the custody of both Mr. Holliday and Dr. B. Rashis of PM TRADE.

A letter from the Armor Board to PM TRADE is shown here.

Mr. Holliday/ey/464-4100

ATZK-AE-TA

9 November 1977

SUBJECT: Observations on Thermal Target Experiment at Fort Knox,
Kentucky, 20-28 October 1977

PM, TRADE
Naval Training Equipment Center
ATTN: Dr. Bernard Rashis
Orlando, Florida 32813

1. The Thermal Target experiment which took place at Fort Knox from 20-28 October can only be called an overwhelming success. The observations made here are intended to provide you with information on those features which we found a preference for or where we think modifications might enhance the system.
2. Our most important finding is that the targets can in fact be powered by tank batteries. This is a tremendous advantage to Army units in the field. Generators in the quantities needed are difficult to obtain, hard to maintain, and require a great deal of labor to protect them down range. The batteries on the other hand can be readily obtained, are easily maintained and recharged, and require minimal range preparation.
3. The problem experienced during the experiment of targets falling over should not be of major concern. Due to the short preparation time, the target boots were exposed. This caused the target to be easily knocked down by rounds landing short-line. In the future, we would anticipate putting in the target boots in defilade. This should drastically reduce target knock down.
4. During the experiment, the weather was quite adverse with rain and/or damp heavy fog predominating. The materials used for the targets held up very well to the environment.
5. The targets demonstrated the capability to take a large number of hits before needing repair, and the repairs were done under field conditions without an inordinate amount of lost time. It is significant that the moving target had approximately 25 holes and was still operating very well.

ATZK-AE-TA

9 November 1977

SUBJECT: Observations on Thermal Target Experiment at Fort Knox,
Kentucky, 20-28 October 1977

6. As to the targets themselves, I feel that we would opt for a reduced size flank tank for the moving target, but retain the full size flank target at extended ranges. Another area of investigation might be to heat only the upper portion of the tank road wheels. If this presents particular problems in development, however, it is not a major area of concern.

7. In summary, the experiment proved the concept as viable, and it should be pursued in order to provide thermal targetry to the field in the time frame of the fielding of the thermal sights. We look forward to continuing cooperation and dialog and thank you for the professionalism exhibited by all of your personnel connected with the project.

FOR THE PRESIDENT:

CHARLES L. KNAPP
LTC Armor
Executive Officer

SEE VOLUME 2

Figure V-5. Flank Target (0 mph wind)

SEE VOLUME 2

Figure V-6. Flank Target (17 mph wind)

SEE VOLUME 2

Figure V-7. Flank Target (25 mph wind)

SEE VOLUME 2

Figure V-8. Frontal Target (0 mph wind)

SEE VOLUME 2

Figure V-9. Frontal Target (15 mph wind)

SEE VOLUME 2

Figure V-10. Frontal Target (25 mph wind)

V-10

The test results can be summarized as follows:

- . Thermal Signature Properties: Very realistic, closely resembling the actual tank target.
- . Target Survivability: Comparable to plywood targets now in use on the range, with regular sights.
- . Target Power: The targets proved capable of being powered by tank batteries. (Two or three batteries are required in the field.)
- . Target Reparability: Targets were repaired in the field and in use with up to 32 hits.
- . Field Manufacturability: The targets were manufactured in a range house at Ft. Knox and transported to the range.

This demonstrated that the targets could be locally manufactured.

In addition to three static targets, a moving target was also configured and powered with two tank batteries. This target sustained 32 hits and was still operational. During the tests, two targets were completely destroyed by short rounds. The short rounds hit bedrock in front of the target propelling it and the mud against the targets. This happens with any plywood target. A solution would be to construct a berm in front of the target and necessitate a slight target elevation. This is how the moving target is configured and it is immune to short shots.

Temsheet proved superior to the painted targets for the following reasons:

- . Ease of manufacture. Painted targets are more time-consuming to construct.
- . Lower voltage to power the target. The Temsheet targets can be powered by batteries. The paint targets require a motor generator.
- . Durability.
- . Safety. The higher voltage necessary for painted targets presents a safety problem. Temsheet targets require only 24 or 36 volts and do not present a safety problem.
- . Signature Uniformity. The Temsheet provides a more uniformly heated target.

Both aluminum foil and wire were used to provide electric current to the target's surface material. The gunners have an optical filter they can place in front of their eyepiece. This should be in place to avoid a specular reflection from pieces of aluminum or wire on the range from a damaged target.



Figure V-11. Full-Scale Targets

SEE VOLUME 2

Figure V-12. Frontal Target (Full Scale)

SEE VOLUME 2

Figure V-13. Frontal and Flank Target (Full Scale)

SEE VOLUME 2

Figure V-14. Man and Man Target

V-13

It was noticed that during the daytime, solar heating of the black surface covered by the cellular plastic gave a good signature without any power, due to the "green house" effect. During the night, a weak "negative" image or reverse image was observed by reflecting the cold sky, when the target was not heated. Thus, the targets are marginally useful even in the advent of power failure.

SECTION VI

CONCLUSIONS

This research program has developed the technology for construction of effective thermal signature targets from inexpensive materials.

Target detail was chosen as a compromise of construction ease and thermal signature detail as can be viewed at target ranges of 1400 meters and 2700 meters. However, unlimited detail is feasible using a slight modification of this technology if more detail is required.

This report fully explained thermal signature target technology and also gives plans for local construction of thermal targets.

REFERENCES

1. LaRocca, A. J. and J. G. Braithwaite, "Thermal Signature Targets Study," Environmental Research Institute of Michigan, Ann Arbor, Michigan, June 1977.
2. Duffie, J. H. and W. A. Beckman, "Solar Energy Thermal Processes," John Wiley and Sons, New York, 1974.
3. McAdams, W. H., "Heat Transfer," McGraw-Hill, New York, 1954.

APPENDIX A

PROGRAM TO CALCULATE THERMAL TARGET PERFORMANCE USING THE HP-67 CALCULATOR

The simultaneous solution of the nonlinear equations (5) and (6) may be restated as finding the value of the vector $x = \begin{bmatrix} x_1 \\ x_2 \end{bmatrix}$ such that the vector valued function $f(x) = \begin{bmatrix} f_1(x) \\ f_2(x) \end{bmatrix}$ vanishes. For this approach, define

$$(A-1) \quad x_1 \triangleq T_f$$

$$(A-2) \quad x_2 \triangleq T_b$$

$$(A-3) \quad f_1(x) \triangleq q_{elec} - \epsilon_f \sigma (x_1^4 - T_0^4) - \epsilon_b \sigma (x_2^4 - T_0^4) \\ - h (x_1 - T_0) - h (x_2 - T_0)$$

$$(A-4) \quad f_2(x) \triangleq \frac{k}{t} (x_1 - x_2) - \epsilon_b \sigma (x_2^4 - T_0^4) - h (x_2 - T_0)$$

The solution of these equations may be obtained by the Newton-Raphson method. This method uses an iteration starting with some arbitrary value for x , called x^0 . $f(x)$ evaluated at x^0 is $f(x^0)$ and will be non-zero. The value of $f(x^0 + \Delta x^0)$ will be approximately

$$f(x^0 + \Delta x^0) \approx f(x^0) + \frac{\partial f}{\partial x} (x^0) \Delta x^0.$$

It is desired that the value of $f(x^0 + \Delta x^0)$ vanish and this will be accomplished approximately if we choose Δx^0 such that

$$f(x^0) + \frac{\partial f}{\partial x} (x^0) \Delta x^0 = 0$$

or

$$(A-4) \quad \Delta x^0 = - \frac{\partial f}{\partial x} (x^0)^{-1} f(x^0).$$

Let x^1 be defined as $x^1 \triangleq x^0 + \Delta x^0$. Evidently $f(x^1)$ will still probably not vanish because of the first order approximation made in obtaining Δx^0 in A-4. Thus, the process is continued until $f(x)$ is as close to zero as desired.

That is if we have reached the i , the iteration we have $x^i = x^{i-1} + \Delta x^{i-1}$ and

$$\Delta x^i = -\left[\frac{\partial f(x^i)}{\partial x}\right]^{-1} f(x^i).$$

Thus, for the next iteration $x^{i+1} = x^i + \Delta x^i$.

Because $f(x)$ is a vector valued function of the vector x

$$\frac{\partial f}{\partial x} = \begin{bmatrix} \frac{\partial f_1}{\partial x_1} & \frac{\partial f_1}{\partial x_2} \\ \frac{\partial f_2}{\partial x_1} & \frac{\partial f_2}{\partial x_2} \end{bmatrix}$$

a matrix.

An HP-67 program was developed to perform the iterations and determine the temperature rises $(T_s - T_0)$ and $(T_b - T_0)$ as a function of power input and values for the parameters $\epsilon_s, \epsilon_b, k, t$ and T_0 . The value of h is computed from equation (7). Program documentation giving instruction storage register contents, an example and program code follows.

THERMAL TARGET PROGRAM INSTRUCTIONS

0. Read in the program.
1. Store the Stefan-Boltzmann constant, 5.6697×10^{-8} (watts/sq.M-DEG. C**4) in Register A.
2. Enter VSQUARE/RA into the stack.
 - V in volts
 - R is ohms per square
 - A is the area per square in square meters.
3. Enter the ambient temperature in degrees Celsius into stack.
4. Enter emissivity of back side surface into stack.
5. Enter emissivity of front surface into stack.
6. Press "A".

7. Enter K/T , $K(\text{watts/sq. meter-deg. C})$, T (meters)
 $= 68.1391601 \times K(\text{BTU/hr-sq. ft-deg F}) / T(\text{inches})$
into stack.
8. Enter V (meters/sec.) into stack.
9. Press "B".

RESULTS:---

X register contains the front side Delta T (C).
Y register contains the back side Delta T (C).

SECONDARY REGISTERS

05. $\text{EPSI} = 0.01$.
15. $F1$.
25. $F2$.
35. Iterations needed for convergence.
45. $J(2,1)$ and $J^{*(-1)}(2,1)$.
55. $J(2,2)$ and $J^{*(-1)}(2,2)$.
65. Not used.
75. $J(1,1)$ and $J^{*(-1)}(1,1)$.
85. $J(1,2)$ and $J^{*(-1)}(1,2)$.
95. Determinant of J .

THERMAL TARGET PROGRAM STORAGE LOCATION CONTENTS

- A. Stefan-Boltzmann constant, $\text{SIGMA} = 5.6697 \times 10^{*(-8)}$,
watts/sq. M-deg. C**4.
- B. Front surface emissivity, ES .
- C. Back surface emissivity, EB .
- D. Ambient temperature, $T0$, degrees Kelvin.

E. Electrical power input, V^2/RA , watts/sq. meter.

PRIMARY REGISTERS

0. Thermal conductivity, K/T , watts/sq. M-deg. C.
1. Wind speed, U , meters/second.
2. Convective heat transfer coefficient, H , watts/sq. M-deg. C.
 $H = 5.7 + 3.8U$.
3. Front side temperature, T_S , deg. Kelvin.
4. Back side temperature, T_B , deg. Kelvin.
5. $V^2/RA + 2HTO + (ES + EB) \text{ SIGMA} \cdot T_0^4$.
6. Front emissivity X Stefan-Boltzmann, $\text{SIGMA} \times ES$,
watts/sq. M-Deg. C^4 .
7. Back emissivity X Stefan-Boltzmann, $\text{SIGMA} \times EB$,
watts/sq. M-Deg. C^4 .
8. Total emissivity X Stefan-Boltzmann, $\text{SIGMA}(ES + EB)$,
watts/sq. M-Deg. C^4 .
9. $F1$ & $J1$.

THERMAL TARGET HP67 PROGRAM EXAMPLE

INPUT DATA:

$$V^2/RA = 100$$

$$T_0 = 25 \text{ Deg. C}$$

$$EB = 1.0$$

$$ES = 1.0$$

$$K/T = 20 \text{ watts/sq. M-Deg. C}$$

$$V = 0 \text{ m/sec}$$

#####

FINAL VALUES

SETTING ENG DSP 5

#####

STACK:	A = 56.6970*10**(-9)
X = 5.18281	B = 1.00000
Y = 3.25861	C = 1.00000
Z = 3.00000	D = 298.150
T = 3.00000	E = 100.000

PRIMARY STORAGE

SECONDARY STORAGE

0 = 20.00000	05 = 10.0000 -3
1 = 0.00000	15 = -150.500 -6
2 = 5.70000	25 = -59.5000 -6
3 = 303.333	35 = 3.00000
4 = 301.409	45 = -32.1511 -3
5 = 4.39495 3	55 = -19.3383 -3
6 = 56.6970 -9	65 = 0.00000
7 = 56.6970 -9	75 = -51.2969 -3
8 = 113.394 -9	85 = 19.1459 -3
9 = -12.0296	95 = 622.063

THERMAL TARGET HP67 PROGRAM

```

000
  31 25 11 *LBL A   Stores front & back emissivity, ambient temp.,
  33 12     STO B   & watts per square meter input power.
  35 53     DNS     Mnemonic for stack roll-down.
  33 13     STO C
005 35 53     DNS
  02       2       Converts Celsius to Kelvin.
  07       7
  03       3
  83
010 01       1
  05       5
  61       +
  33 14     STO D   Ambient temperature (Deg. Kelvin).
  35 53     DNS
015 33 15     STO E   Power input (watts/square meter).
  35 22     RTN
  31 25 12 *LBL B   Stores conductivity (W/SQ. M-C) & wind vel. (m/sec).
  33 01     STO 1
  35 53     DNS

```

020	33 00	STO 0	
	31 25 13	*LBL C	Computes & stores program constants.
	31 42	SWS	Mnemonic for swap storage registers.
	00	0	
	33 03	STO 3	Initializes iteration count.
025	83		
	00	0	
	01	1	
	33 00	STO 0	Initializes Epsilon --- for iteration escape.
	31 42	SWS	
030	34 14	RCL D	
	33 03	STO 3	Initial surface temp. = ambient temp.
	33 04	STO 4	Initial back temp. = ambient temp.
	05	5	
	83		
035	07	7	
	41	ENT	Mnemonic for enter.
	03	3	
	83		
	08	8	
040	34 01	RCL 1	
	71	X	
	61	+	
	33 02	STO 2	Heat transfer coefficient (w/sq. meter-Deg. C).
	34 11	RCL A	Stefan-Boltzmann, 5.6697×10^{-8} w/sq. $M-T^{**4}$.
045	34 12	RCL B	
	71	X	
	33 06	STO 6	Back emissivity X Stefan-Boltzmann.
	34 11	RCL A	
	34 13	RCL C	
050	71	X	
	33 07	STO 7	Front surface emissivity X Stefan-Boltzmann.
	61	+	
	33 08	STO 8	Emissivity sum X Stefan-Boltzmann.
	34 14	RCL D	
055	04	4	
	35 63	YEX	Mnemonic for Y EXP X.
	71	X	
	02	2	
	34 02	RCL 2	
060	71	X	
	34 14	RCL D	
	71	X	
	61	+	
	34 15	RCL E	
065	61	+	
	33 05	STO 5	Heat contribution of ambient conditions.
	31 25 14	*LBL D	Start of Newton-Raphson iterations.
	34 05	RCL 5	
	34 02	RCL 2	

070	34 03	RCL 3	
	71	X	
	51	-	
	34 03	RCL 3	
	04	4	
075	35 63	YEX	
	34 06	RCL 6	
	71	X	
	51	-	
	34 04	RCL 4	
080	34 02	RCL 2	
	71	X	
	51	-	
	34 04	RCL 4	
	04	4	
085	35 63	YEX	
	34 07	RCL 7	
	71	X	
	51	-	
	33 09	STO 9	F1.
090	34 02	RCL 2	
	34 14	RCL D	
	71	X	
	34 14	RCL D	
	04	4	
095	35 63	YEX	
	34 07	RCL 7	
	71	X	
	61	+	
	34 00	RCL 0	
100	34 03	RCL 3	
	71	X	
	61	+	
	34 00	RCL 0	
	34 02	RCL 2	
105	61	+	
	34 04	RCL 4	
	71	X	
	51	-	
	34 04	RCL 4	
110	04	4	
	35 63	YEX	
	34 07	RCL 7	
	71	X	
	51	-	
115	34 09	RCL 9	
	31 42	SWS	
	33 01	STO 1	F1.
	35 53	DNS	
	33 02	STO 2	F2.

120	31	42	SWS	
	34	02	RCL 2	
	34	06	RCL 6	
	04		4	
	71		X	
125	34	03	RCL 3	
	03		3	
	35	63	YEX	
	71		X	
	61		+	
130	42		CHS	
	33	09	STO 9	J(1,1),
	34	02	RCL 2	
	34	07	RCL 7	
	04		4	
135	71		X	
	34	04	RCL 4	
	03		3	
	35	63	YEX	
	71		X	
140	61		+	
	42		CHS	
	41		ENT	
	41		ENT	
	34	00	RCL 0	
145	51		-	
	34	09	RCL 9	
	34	00	RCL 0	
	31	42	SWS	
	33	04	STO 4	J(2,1).
150	35	53	DNS	
	33	07	STO 7	J(1,1).
	35	53	DNS	
	33	05	STO 5	J(2,2).
	35	53	DNS	
155	33	08	STO 8	J(1,2).
	34	07	RCL 7	
	34	05	RCL 5	
	71		X	
	34	04	RCL 4	
160	34	08	RCL 8	
	71		X	
	51		-	
	33	09	STO 9	Determinant of J.
	34	05	RCL 5	
165	34	09	RCL 9	
	81		DIV	Mnemonic for divide.
	34	07	RCL 7	
	34	09	RCL 9	
	81		DIV	

170	33 05	STO 5	J inverse (2,2).
	35 53	DNS	
	33 07	STO 7	J inverse (1,1).
	34 08	RCL 8	
	34 09	RCL 9	
175	81	DIV	
	42	CHS	
	33 08	STO 8	J inverse (1,2).
	34 04	RCL 4	
	34 09	RCL 9	
180	81	DIV	
	42	CHS	
	33 04	STO 4	J inverse (2,1).
	34 07	RCL 7	
	34 01	RCL 1	
185	71	X	
	34 08	RCL 8	
	34 02	RCL 2	
	71	X	
	61	+	
190	42	CHS	Delta X1.
	34 04	RCL 4	
	34 01	RCL 1	
	71	X	
	34 05	RCL 5	
195	34 02	RCL 2	
	71	X	
	61	+	
	42	CHS	Delta X2.
	01	1	
200	33 61 03	STO + 3	Increment count.
	35 53	DNS	
	32 72	RTP	Mnemonic for rectangular to polar conversion.
	34 00	RCL 0	
	32 81	XGY	Mnemonic for X greater than Y?
205	22 31 11	GTO FA	Iterations finished, go to clean-up.
	35 53	DNS	
	31 72	PTR	Mnemonic for polar to rectangular conversion.
	31 42	SWS	
	33 61 04	STO +4	
210	35 53	DNS	
	33 61 03	STO +3	
	22 14	GTO D	Return for another iteration.
	32 25 11	*LBLF A	Clean-up.
	34 03	RCL 3	
215	31 42	SWS	
	34 04	RCL 4	
	34 14	RCL D	
	51	-	
	34 03	RCL 3	
220	34 14	RCL D	
	51	-	
	84	R/S	Front temp displayed, back temp in Y register.