

# Moss Landing Marine Laboratories

P. O. Box 450 Moss Landing, CA 95039-0450 (408) 633-3304

## EFFECTS OF ATOC SOUNDS ON THE HARBOR SEAL, *PHOCA VITULINA RICHARDSI*, IN MONTEREY BAY

JAMES T. HARVEY  
TOMO HARU EGUCHI

19971021 269

Moss Landing Marine Laboratories Technical Publication No. 97-1

**DISTRIBUTION STATEMENT B**

Approved for public release;  
Distribution Unlimited

MAR 27 1997

ERIC QUARME INTERCOMS & MARCH 1997

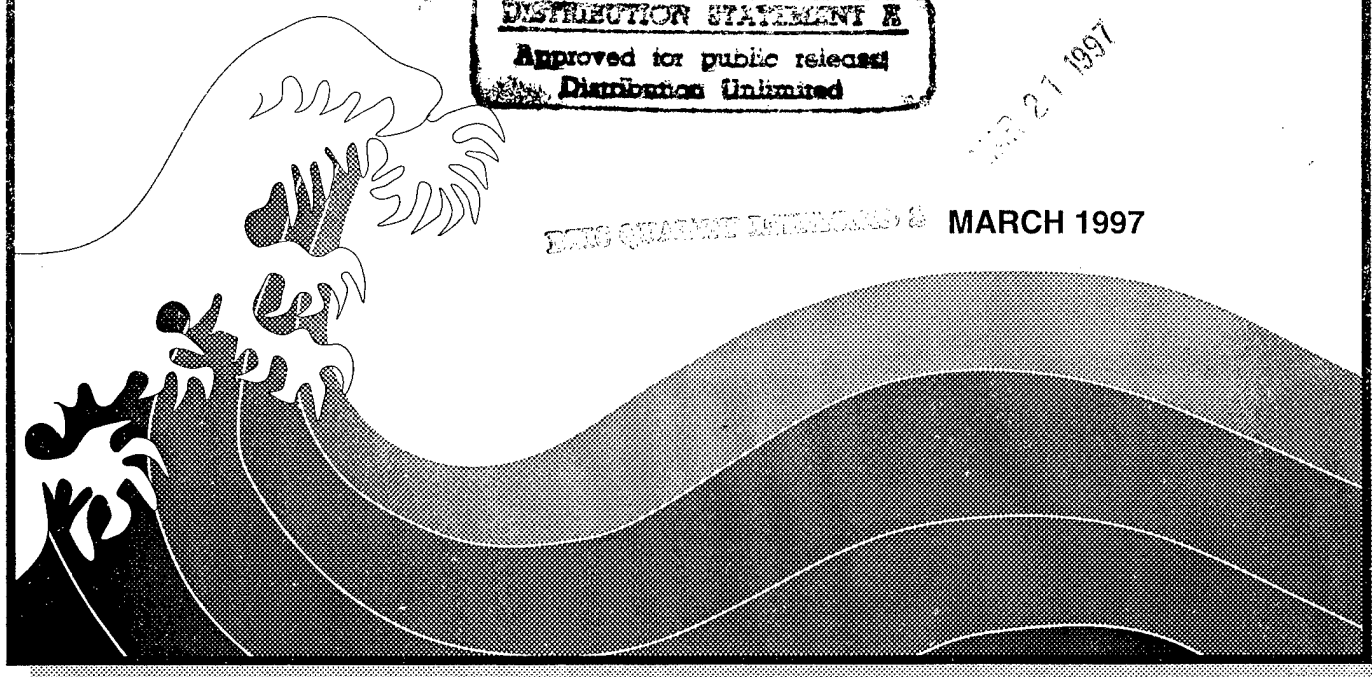
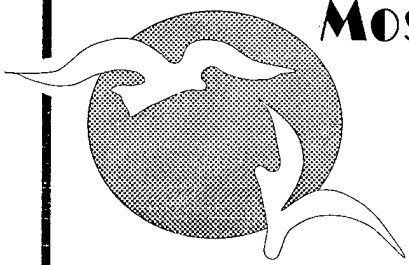

# REPORT DOCUMENTATION PAGE

Form Approved  
OMB No. 0704-0188

Public reporting burden for this collection of information is estimated to average 1 hour per response, including the time for reviewing instructions, searching existing data sources, gathering and maintaining the data needed, and completing and reviewing the collection of information. Send comments regarding this burden estimate or any other aspect of this collection of information, including suggestions for reducing this burden, to Washington Headquarters Services, Directorate for Information Operations and Reports, 1215 Jefferson Davis Highway, Suite 1204, Arlington, VA 22202-4302, and to the Office of Management and Budget, Paperwork Reduction Project (0704-0188), Washington, DC 20503.

1. AGENCY USE ONLY (Leave Blank)		2. REPORT DATE 8 March 1997	3. REPORT TYPE AND DATES COVERED Final Report	
4. TITLE AND SUBTITLE Effects of ATOC sounds on the harbor seal, <i>Phoca vitulina richardsi</i> , in Monterey Bay.			5. FUNDING NUMBERS G: N00014-94-1-1075  PR: 3231227---01	
6. AUTHOR(S) James T. Harvey Tomoharu Eguchi			8. PERFORMING ORGANIZATION REPORT NUMBER MLML Tech. Publ. 97-1	
7. PERFORMING ORGANIZATION NAME(S) AND ADDRESS(ES) Moss Landing Marine Laboratories. P.O. Box 450 Moss Landing, CA 95039-0450			9. SPONSORING/MONITORING AGENCY NAME(S) AND ADDRESS(ES) Department of the Navy Office of Naval Research 800 North Quincy Street Arlington, VA 22217-5660	
11. SUPPLEMENTARY NOTES To be published in a refered professional journal (possibly Marine Mammal Science or Journal of Mammalogy)				
12a. DISTRIBUTION/AVAILABILITY STATEMENT  <b>DISTRIBUTION STATEMENT A</b> Approved for public release Distribution Unlimited			12b. DISTRIBUTION CODE  MAR 27 1997	
13. ABSTRACT (Maximum 200 words)  The purpose of this study was to determine any effects of ATOC signals (low frequency sounds) on the diving behavior and heart rate of harbor seals near Point Sur, California. Harbor seals (n=149; 92 males, 57 females) were captured in Elkhorn Slough, California between June 1994 and November 1996. To determine diving and foraging behavior, time-depth-recorders (TDRs) and radio tags were placed on 33 harbor seals and 19 also outfitted with heart rate monitors. Radio-tagged harbor seals occasionally moved from Elkhorn Slough to haul-out sites at Ano Nuevo, Monterey, Point Lobos, Yankee Point, and Point Sur, all returned to the slough. Harbor seals fed on the oceanic shelf, along the shelf break of the Monterey Submarine Canyon, and off Sunset State Beach. Twenty-eight TDRs were recovered (n=16,403 dives), more dives were recorded at night (mean=574 dives) than daytime (mean=337 dives). There was no difference in the duration or depth of dives between daytime and nighttime. Harbor seal dives sometimes exceeded 500 m depth and 30 min duration. Because of variable heart rates and the behavior of seals we were unable to determine if there was any effect of the ATOC-like sounds projected toward harbor seals underwater. Based on transmission loss, depth of dive, and distance harbor seal occur from shore, we concluded there is negligible chance that harbor seals would be affected by the ATOC sound source on Pioneer Seamount.				
14. SUBJECT TERMS Harbor seals, ATOC sound source, diving behavior, low frequency sounds			15. NUMBER OF PAGES 55 pages	
			16. PRICE CODE	
17. SECURITY CLASSIFICATION OF REPORT	18. SECURITY CLASSIFICATION OF THIS PAGE	19. SECURITY CLASSIFICATION OF ABSTRACT	20. LIMITATION OF ABSTRACT UL	

**Effects of ATOC sounds on the harbor seal,  
*Phoca vitulina richardsi*, in Monterey Bay**

Submitted to:

The Office of Naval Research  
800 North Quincy Street  
Arlington, VA 22217-5660

Contract Number: N00014-94-14075  
R&T Code: 4113-011

Submitted by:

James T. Harvey  
Tomoharu Eguchi

Moss Landing Marine Laboratories  
P.O. Box 450  
Moss Landing, CA 95039-0450

MLML Technical Publication No. 97-01

8 March 1997

### Abstract

Harbor seals ( $n=149$ ) were captured in Elkhorn Slough between June 1994 and November 1996 (92 males and 57 females). Greater number of male harbor seals were captured than females ( $\chi^2 = 8.595$ ,  $p = 0.0034$ ). Standard length of harbor seals in Elkhorn Slough ranged from 74 to 169 cm, whereas weight ranged from 7.9 to 131.5 kg. Males were larger in length ( $\bar{x}_{\text{male}} = 131.8$  cm,  $SE_{\text{male}} = 2.51$ ,  $n_{\text{male}} = 89$ ;  $\bar{x}_{\text{female}} = 124.2$  cm,  $SE_{\text{female}} = 2.41$ ,  $n_{\text{female}} = 56$ ;  $t = 2.06$ ,  $df = 143$ ,  $p = 0.042$ ) and weight ( $\bar{x}_{\text{male}} = 63.5$  kg,  $SE_{\text{male}} = 3.02$ ,  $n_{\text{male}} = 90$ ;  $\bar{x}_{\text{female}} = 51.4$  kg,  $SE_{\text{female}} = 2.79$ ,  $n_{\text{female}} = 57$ ;  $t = 2.76$ ,  $df = 145$ ,  $p = 0.0066$ ) than females but no difference between sexes was found in axillary girth ( $\bar{x}_{\text{male}} = 97.1$  cm,  $SE_{\text{male}} = 2.18$ ,  $n_{\text{male}} = 80$ ;  $\bar{x}_{\text{female}} = 93.0$  cm,  $SE_{\text{female}} = 2.14$ ,  $n_{\text{female}} = 52$ ;  $t = 1.28$ ,  $df = 130$ ,  $p = 0.202$ ). A positive linear relationship was found between length and girth of harbor seals in Elkhorn Slough (girth =  $10.858 + 0.662 \times (\text{length})$ ,  $r^2 = 0.791$ ). An exponential relationship was found between weight and standard length of harbor seals in Elkhorn Slough ( $\log(\text{weight}) = 0.455 + 0.01 \times (\text{length})$ ,  $r^2 = 0.896$ ). No difference was found in regression coefficients of length and girth, and length and weight between males and females. The average growth rate of 16 recaptured harbor seals was 6.84 kg/yr ( $SE = 4.38$ ), whereas the average growth rate of 12 seals with positive growth rate was 15.39 kg/yr ( $SE = 2.08$ ). To estimate effects of "ATOC-like" transmissions on diving behavior of the Pacific harbor seal, 33 TDRs and radio transmitters, and 19 heart rate monitors were deployed on harbor seals in Elkhorn Slough, California between June 1994 and November 1996. Radio-tagged harbor seals occasionally moved from Elkhorn Slough to Año Nuevo, Hopkins Marine Station, Point Lobos, Yankee Point, and Point Sur. All seals eventually returned to Elkhorn Slough. Radio-tagged harbor seals fed over the oceanic shelf, along the shelf break of the Monterey submarine canyon, the mouth of Soquel submarine canyon, and off Sunset Beach, and rested in Elkhorn Slough. Twenty-eight TDRs were recovered and 16,403 dives recorded for 18 seals. More dives were recorded between dusk and dawn ( $\bar{x} = 573.9$  dives,  $SE = 99.08$ ) than between dawn and dusk ( $\bar{x} = 337.33$  dives,  $SE = 61.3$ ). No difference was found in the average depth of dives between night ( $\bar{x} = 52.4$  m,  $SE = 9.57$ ,  $n = 18$ ) and day ( $\bar{x} = 49.45$  m,  $SE = 8.74$ ,  $n = 17$ ). No difference was found between the average duration of dives between night ( $\bar{x} = 5.04$  min,  $SE = 0.42$ ,  $n = 18$ ) and day ( $\bar{x} = 4.78$  min,  $SE = 0.46$ ,  $n = 17$ ). Dives were deeper during the late summer and early winter than the remainder of the year. The maximum depth of dives were positively correlated with average rate of descent and the average rate of ascent. Because of the great variability of heart rate of harbor seals, direct estimates of effects of the "ATOC-like" sound on diving behavior and heart rate of harbor seals were not measured. The transmission loss experiments indicated, however, the M-sequence (i.e. "ATOC-like" transmission) attenuated rapidly in shallow water, indicating negligible effects of the ATOC sound source off Pillar Point on harbor seals in the Monterey Bay area.

## Introduction

Increased number of humans and their activities have resulted in increased consumption of natural resources and expansion of human habitats. Human consumption of natural resources has reduced suitable habitats for many species of animals and plants. In some cases, a reduction in population size has resulted from habitat loss. Human activities in wildlife have altered behavior of wild animals (e.g. the black bear, *Ursus americanus*; Keay 1995, and the cougar, *Puma concolor*; Spreadbury et al. 1996). Human activities along the coast line, such as kayaking and boating, have increased the possibility of harassing marine mammals ashore.

Human activities in wildlife habitats often have negative impacts on various species and these effects may be short term or long term. Short-term disturbances of wildlife include military activity and mule deer (*Odocoileus hemionus*; Stephenson et al. 1996); snow mobiles and white-tailed deer (*Odocoileus virginianus*; Dorrance et al. 1975); installation of oil wells affecting elk (*Cervus elaphus*; Van Dyke and Klein 1996); and kayaks, canoes, and boat traffic disrupting harbor seals ashore (Allen et al. 1984, Suryan 1995). These studies indicated animals changed their use of range, centers of activities, and moved away from disturbance sources. Although these short-term disturbances may not reduce the reproductive success of a population, continuous harassment may cause abandonment of certain areas (Allen 1991) and reduction in suitable habitats.

Long-term negative impacts of human activities on wildlife include a decline in the population to extinction of a species. For example, sirenian populations, all of which are limited to coastal shallow waters or river systems, have decreased dramatically as a consequence of habitat destruction and accidental collisions with boats and ships (Reeves et al. 1992). Although the exact cause is unknown, the decline of the northern sea lion (*Eumetopias jubatus*) is believed

to be linked with incidental mortality in commercial fishing gear, shooting by fishermen, and reduction of important prey items, such as the walleye pollock (*Theragra chalcogramma*) by commercial fishing operations (Reeves et al. 1992).

Continuous habitat degradation (intentional or unintentional) also negatively affects wildlife. An example of intentional habitat degradation is the deforestation of an old-growth forest, which removes suitable habitats for animals and plants. Unintentional habitat degradation may include oil spills, toxic runoff from agricultural fields, and acoustic noise. Effects of oil spills on wildlife have been demonstrated in many occasions (e.g. Jordan and Payne 1980, Amoco Cadiz oil spill; NOAA-CNEXO 1982, Exxon Valdez oil spill; Townsend and Heneman 1989). Effects of toxic runoff from agricultural fields on wildlife drew attention when a negative relationship was found between amount of DDT and thickness of egg shells of Brown Pelican (*Pelecanus occidentalis*, Anderson and Risebrough 1976). A similar finding has been reported for Caspian Terns (*Sterna caspia*) in Elkhorn Slough, California (J. Parkin, pers. comm.).

Possible negative effects of anthropogenic noise on wildlife have been reported for desert ungulates (Weisenberger et al. 1996) and several marine mammals (Terhune et al. 1979, Awbrey and Stewart 1983, Dahlheim and Fisher 1983, Myrberg 1990, Norris 1995). Weisenberger et al. (1996) reported a change in behavior and short-term increase in heart rates of desert mule deer (*Odocoileus hemionus crooki*) and mountain sheep (*Ovis canadensis mexicana*) during simulated jet aircraft noise. Animals, however, habituated to the simulated noise and responses to the introduced noise decreased with increased exposure (Weisenberger et al. 1996). Terhune et al. (1979) reported decrease in harp seal (*Phoca groenlandica*) vocalizations when a vessel approached. Possible disturbances caused by icebreakers were reported for the beluga (*Delphinapterus leucas*), the narwhal (*Monodon monoceros*; Cosens and Dueck 1993), and the

walrus (*Odobenus rosmarus*; Brueggeman et al. 1992). Norris (1995) reported possible effects of large boat noise on singing behavior of humpback whales off the Hawaiian islands. Low-flying aircrafts were blamed for the deaths of more than 10% of pups born on one Alaskan island in 1976 (Johnson 1977). More studies are necessary to understand possible effects of underwater anthropogenic noise on marine mammals.

Noise in the oceans comes from numerous sources. In addition to natural sound sources, such as wind, waves, undersea earthquakes, seafloor volcano eruptions, lightning, and various biological noises (e.g. shrimp, fish, and whales), humans have introduced a great amount of noise into the ocean. Loud ( $> 180$  dB re  $1\mu\text{Pa}$  @ 1m) man-made underwater sound sources include large ships, icebreakers, offshore drilling, offshore dredging, explosions, geological surveys (airgun array), and physical oceanographic surveys (such as acoustic thermometry; Greene 1995b). Because sound travels through water more efficiently than air, sound can affect a broader area in water than on land.

The Acoustic Thermometry of Ocean Climate (ATOC) project, which is monitoring changes in global ocean temperature using acoustic transmissions, is another source of man-made underwater noise that may affect marine organisms. The purpose of the ATOC project is to observe ocean climate in large spatial (3,000 to 10,000 km) and temporal (10 to 20 years) scales to test global climate models. If the models prove adequate, data from the ATOC project will be used to make meaningful predictions of change in global climate (Final EIR/EIS for the California ATOC project and its associated MMRP 1995). The basic principle behind the ATOC project is to measure differences in sound speed underwater through time to detect the change in the ocean temperature. Because sound travels faster in warm water than in cold water, the travel time of a sound pulse from a source to a receiver will decrease if the ocean warms and will increase if the

ocean cools. The proposed system uses an acoustic channel (sound fixing and ranging, or SOFAR, channel) to transmit a coded signal over long distances. The sound produced by the ATOC sources are a digitally-coded low frequency rumble (center frequency of 75 Hz and bandwidth of 35 Hz, 195 dB re 1 $\mu$ Pa@1m), which can be detected at receiving stations even if the sound was below the ambient background noise (Final EIR/EIS for the California ATOC project and its associated MMRP 1995).

Two ATOC sound sources (one off central California, the other off the north shore of Kauai, Hawaii) and several receiving stations (hydrophone arrays in the South Pacific, near Rarotonga, in the mid Pacific, and several other existing Navy facilities in the North Pacific) were proposed for the two-year demonstration period (1996-1997; Final EIR/EIS for the California ATOC project and its associated MMRP 1995). The original site for the sound source off central California was 40 km west of Pt. Sur, on Sur Ridge at a depth of approximately 850 m (36° 18.1' N, 122° 19.3' W, preferred site; Fig. 1). Due to the public concern about disturbances on the sea floor of the Monterey National Marine Sanctuary, the site was moved to 88 km west of Pillar Point, on Pioneer Seamount at a depth of approximately 980 m (37° 20.6' N, 123° 26.7' W, alternate site; Final EIR/EIS for the California ATOC project and its associated MMRP 1995; Fig. 1).

Because the ATOC sound source and many other anthropogenic noises are located nearshore, species that utilize resources within coastal waters are more likely affected by these sound sources than oceanic species. Pinnipeds, in particular, are affected by aerial and underwater noises because of their amphibious behavior. Five pinniped species inhabit the central coast of California: the northern elephant seal (*Mirounga angustirostris*), the California sea lion (*Zalophus californianus*), the Pacific harbor seal (*Phoca vitulina richardsi*), the northern sea lion (*Eumetopias jubatus*), and the northern fur seal (*Callorhinus ursinus*). Because northern elephant

seals, California sea lions, and harbor seals are abundant in populated areas and near the ATOC sound source off central coast of California, effects of the ATOC sound source on these species need to be examined.

The Pacific harbor seal is an abundant resident along the central coast of California. Approximately 18,700 seals inhabit the California coast (Hanan et al. 1993). Because harbor seals rest ashore (haul out) on coastal rocks, beaches, and mudflats, human activities greatly affect their behavior. Allen et al. (1984) reported human activities, especially people in canoes, affected seals ashore at Bolinas Lagoon, California. Off the northern San Juan islands of Washington, power boats were the primary source of harassment of harbor seals ashore (Suryan 1995). In both studies, seals entered the water when harassed by canoes or boats. Disturbances underwater, however, have been unreported because hearing and underwater behavior of harbor seals is not well documented.

Hearing ability of harbor seals has been examined in a few studies. Møhl (1968) first produced an audiogram of a harbor seal for frequencies between 1 kHz and 256 kHz. The seal had a good response from 1 kHz to 40 kHz. Kastak (1996) examined the hearing ability of a harbor seal in a controlled tank and demonstrated the hearing threshold of a harbor seal at 100 Hz was 96 dB (95% CI = 94.67-97.77), whereas at 75 Hz the hearing threshold was approximately 100 dB. He estimated that a harbor seal could hear the ATOC sound approximately 160 km from the sound source, assuming spherical spreading ( $20\log R$ ) to 1000 m from the source and " $15\log R$ " spreading thereafter.

This study was designed and funded by the Office of Naval Research (ONR) when the ATOC sound source off central California was proposed for deployment off Point Sur. Initial objectives of this study were to; (1) estimate diving behavior and movements of harbor seals off

Big Sur, (2) monitor short-term physiological (change in heart rate) and behavioral (changes in duration and depth of dives) responses of harbor seals to the ATOC transmissions, and (3) evaluate ability of harbor seals to acclimate to low-frequency sound off Point Sur. To meet these objectives, we proposed that we would place time-depth recorders and heart monitors on harbor seals off the Big Sur coast and monitor the effects of ATOC signals. Because the ATOC sound source was moved from Sur Ridge to Pioneer Seamount, it was unlikely that coastal harbor seals would be exposed to ATOC signals. Consequently, the initial objectives were changed to the following: (1) estimation of effects of 'ATOC-like' transmissions on change in heart rate and diving behavior of harbor seals in Monterey Bay, (2) growth estimates of harbor seals in Elkhorn Slough, (3) estimation of foraging areas of harbor seals in Monterey Bay, (4) estimation of diving behavior and activity patterns of harbor seals in Monterey Bay, and (5) evaluation of change in heart rates of free-ranging harbor seals.

We hypothesized that (1) no effects of 'ATOC-like' transmissions on heart rate, duration, and depth of dives would be observed because of great variabilities in these statistics, the decreased sound source level of an underwater speaker compared with the ATOC sound source, and many ambient noise sources in the coastal waters, (2) harbor seals would show nocturnal feeding behavior in Monterey Bay, and majority of feeding would occur off Sunset Beach, (3) maximum duration of dives would be 20 minutes, and maximum depth of dives would be less than 200 m, and (4) heart rates would decrease during diving and increase as seals come to the surface.

### Methods

Harbor seals ( $n = 149$ ) were captured during 21 tagging sessions in Elkhorn Slough between June 1994 and November 1996, using the method described in Jeffries et al. (1993). A

capture attempt was made every month except for March and December (Table 1). Weight, length, and girth of each seal were determined. Plastic cattle ear tags with unique numbers were attached to hind flippers between the second and third digits. Recaptured seals were measured and weighed. Growth of recaptured animals was estimated by plotting the change in weight and the duration of time between two consecutive capture dates. Measurement data from previous years (1991,  $n = 8$  and 1993,  $n = 11$ ) also were combined for these analyses.

To estimate movements of harbor seals offshore, VHF transmitters (164 to 166 MHz, Advanced Telemetry System (ATS), Isanti, MN) were deployed on 38 seals. A VHF transmitter was secured on a rubber patch ( $3 \times 5 \times 0.3$  cm) by two cable ties and then glued on a seal's head with industrial strength instant adhesive (Loctite 422, Loctite Corporation, Newington, CT). To identify, locate, and track tagged seals, a unique frequency was used with each individual. Seals were tracked at least twice a week for two to four weeks from shore. A triangulation method was used to locate seals offshore.

Diving behavior of harbor seals was recorded using time-depth recorders (TDRs, Mk3e, Wildlife Computers, Redmond, WA). A time-depth recorder is a microprocessor controlled data recorder, which records time and pressure at a programmed frequency. Data were stored in on-board memory chips and downloaded to a personal computer for analyses. Consequently, recovery of TDRs was critical for retrieving data. Without a remote release mechanism, the location and time of the detachment of a TDR are not controllable. Because a TDR was negatively buoyant, flotation was necessary to keep the TDR at the ocean surface when it detached from a seal.

Flotation for a TDR was made from Syntactic Foam (Flotation Technologies, Biddeford, ME) and placed around each TDR (Fig. 2). A radio transmitter (164 to 166 MHz, ATS) was

inserted in the flotation to locate the TDR when it floated at the ocean surface. The flotation was painted fluorescent orange. Time depth recorder, flotation, and VHF transmitter are called collectively hereafter a backpack. A backpack was approximately 25cm in length, 5cm in diameter, and weighed approximately 400g (Fig. 2).

A backpack was attached to the base plate using three methods: 1) a c-clamp, a magnesium bolt (5/8 inch), and steel nuts, 2) a U-shaped aluminum bracket, a magnesium bolt (5/8 inch) and steel nuts, and 3) two U-shaped aluminum brackets, stainless steel wire (1/32 inch diameter), and the remote release mechanism. For the first method, the base plate was glued to the seal via a metal plate or neoprene patch. Fast-setting epoxy (Devcon, Wood Dale, IL) or instant adhesive (Loctite 422) was used to secure the plate to the dorsal pelage of the seal. For the second method, a U-shaped bracket was glued between two rubber patches ( $5 \times 7 \times 0.3$  cm). A magnesium bolt was inserted through a hole in the backpack and secured to the bracket using steel washers and nuts. The rubber patch was glued to the seal using the instant adhesive. Magnesium bolts corroded in sea water and the backpack was released. Differences in activity among seals were most likely the cause of variability in corrosion rates. The final method used was a remote release mechanism (RRM). The RRM was designed and built by Jamie Stamps (Sandia National Laboratories, Livermore, CA) to release TDRs from marine mammals in collaboration with University of California at Santa Cruz (Dr. D. Croll) and Moss Landing Marine Laboratories. The RRM consisted of receiving and transmitting units. The receiving unit consisted of an electric circuit, two AAA (or AA) batteries connected in series (3 V), and a wire cutter, and was glued in each backpack. The circuit was designed to recognize a coded signal (frequency modulated, base frequency 144 MHz). When the circuit received the signal, an open circuit was created. The electric current, was then able to ignite an explosive, which actuated a

stainless steel blade (Guillotine, Quantic Industries, Inc. Hollister, CA) and cut the wire. A frequency generator, multiple amplifiers, and antenna were used to transmit the signal. A magnesium bolt was used as a back-up detachment method. Backpacks were detached or released from seals within a few days to four weeks of deployment and floated at the water's surface or remained on mud-flats in Elkhorn Slough until they were retrieved.

Thirty-three TDRs were deployed on adult harbor seals (19 males and 14 females) from July 1994 to November 1996. Data in a retrieved TDR were downloaded to a personal computer upon recovery of the backpack. The dive analysis software from Wildlife Computers was used to calculate statistics of recorded dives. Each dive was visually inspected for possible concatenation of multiple dives by the software. To avoid possible bias from brief submersions of a seal, dives less than 30 seconds were excluded from all analyses. Dives within Elkhorn Slough also were excluded because seals use the slough for resting rather than foraging (Oxman 1995). Harbor seals in Elkhorn Slough spent approximately one hour departing the slough after entering the water. When the exact time of departure from the slough was unknown, therefore, all dives within one hour after the seal entered the water from its haul-out were considered to be recorded in the slough. If dives deeper than 10 m were recorded within the one hour period, however, these dives were considered offshore. The following statistics were calculated for each dive: maximum depth, duration of dive, and descent and ascent rates.

Heart rate monitors were deployed on 19 harbor seals (11 males and 8 females) between February 1995 and November 1996. Heart rates of harbor seals were measured via two surface mounted electrodes (stainless steel fender washers) and heart rate transmitters, which sent an amplified signal to the TDR. Two areas on the dorsal pelage approximately 2.5 cm in diameter, one on either side of vertebrae posterior to scapula, were shaved with an electric razor.

Conductivity gel (Lectron II, Pharmaceutical Innovations, Inc., Newark, NJ) was applied on electrodes. A rubber base, which held the backpack and electrodes, was glued to the dorsal pelage using the instant adhesive (Fig. 2). Heart rate data were counted for 30 seconds and stored as beats per minute (bpm) in the memory of the TDR with depth and time data. This enabled correlations in change in depth and heart rates to be calculated. Heart rates also were measured during the tagging procedure using a hand-held heart rate monitor (Polar, Port Washington, NY).

From August to November 1996, five seals with TDRs were exposed to 'ATOC-like' transmissions (playback experiments). Recorded ATOC sound (M-sequence) was played back using a digital audio tape (DAT) recorder (Sony TCD-D8 or D10), amplified by a power amplifier (Techron 7560, Techron, Elkhart, IN), and broadcasted through a underwater transducer (J-15-1, Naval Research Lab., Orlando, FL). The transducer was suspended 20 m below the surface from a research vessel (R/V Ricketts, Moss Landing Marine Laboratories). Location of the vessel was recorded every 30 minutes using a global positioning system (GPS).

Playback experiments were conducted during early morning when tagged seals were returning from their feeding areas to Elkhorn Slough. Location of tagged seals offshore was continuously monitored by radio-tracking the seals from two shore stations the night before a playback experiment. To estimate the distance between the sound source and tagged seals, shore-based observers with directional antennas and hand-held receivers at two shore stations located harbor seals offshore every 30 minutes before and during the playback experiment. The research vessel was located as close to a tagged seal as possible and started broadcasting the M-sequence up to four times per day: 20 minutes of transmission followed by at least 40 minutes of silence (a pattern similar to the ATOC source). Except for a generator (Honda EX4500S), which powered

the amplifier, all noise sources on board was turned off (e.g. engine and echo-sounder). To minimize possible negative effects of the M-sequence on other marine mammals, a brief visual observation was conducted prior to the M-sequence transmission to ensure no other marine mammals were visible in the area.

To estimate received levels of the 'ATOC-like' transmissions by harbor seals, a separate experiment was conducted. Three spur buoys with hydrophones and DAT recorders (Sony TCD-D8) were placed at various distances from the sound source and underwater noise recorded. A hand-held GPS was placed in each spur buoy to record the exact location of the buoy. Distances among buoys and the vessel were calculated. An additional hydrophone was suspended 1 m above the transducer to measure the source level. Recordings were analyzed later to estimate the transmission loss of the M-sequence in the shallow water in Monterey Bay.

## Results

A greater number of male harbor seals were captured in Elkhorn Slough than female ( $N_{\text{male}} = 103$ ,  $N_{\text{female}} = 65$ ,  $\chi^2 = 8.595$ ,  $p = 0.0034$ ) between September 1991 and November 1996. The number of females captured per tagging session, however, was greater during summer (May to August, 4.625 females per catch) than other months of the year (2.17 females per catch; Fig. 3).

Standard lengths of harbor seals in Elkhorn Slough were 74 to 169 cm, whereas, weights ranged from 7.9 to 131.5 kg (Table 2). Axillary girth of harbor seals ranged from 31 to 134 cm (Table 2). Males were larger in length ( $t = 2.06$ ,  $df = 143$ ,  $p = 0.042$ ) and weight ( $t = 2.76$ ,  $df = 145$ ,  $p = 0.0066$ ) than females. No difference, however, was found in axillary girth of male and female harbor seals ( $t = 1.28$ ,  $df = 130$ ,  $p = 0.202$ ; Table 2).

A positive linear relationship was found between length and girth of harbor seals captured

in Elkhorn Slough (girth =  $10.858 + 0.662 \times (\text{length})$ ,  $r^2 = 0.791$ ,  $n = 148$ ,  $p < 0.0001$ , Fig. 4). An exponential relationship was found between weight and standard length ( $\log(\text{weight}) = 0.455 + 0.01 \times (\text{length})$ ,  $r^2 = 0.896$ ,  $n = 160$ ,  $p < 0.0001$ , Fig. 4). Because there was no difference in regression coefficients of length and girth, and length and weight of males and females, data for males and females were pooled.

Growth was estimated for 16 harbor seals recaptured in Elkhorn Slough (Fig. 5). One seal was captured three times in a two year period (seal ID# 278). Therefore, the average of the two time periods between captures was used as the best estimate of the growth of the seal. Positive growth was measured for twelve seals and negative growth for four seals. The average growth rate of all measurements was 6.84 kg/yr (SE = 4.38,  $n = 16$ ), whereas the average growth rate for the 12 seals with positive growth was 15.39 kg/yr (SE = 2.08,  $n = 12$ ). Smaller seals appeared to grow faster (i.e. greater slopes) than larger seals (Fig. 5). Although there was a statistically significant negative relationship between initial body weight and the growth of 16 harbor seals (growth rate =  $28.67 + (-0.337) \times (\text{initial weight})$ ), the initial body weight explained only 37% of the variability of growth rates ( $r^2 = 0.367$ ).

Harbor seals captured and tagged in Elkhorn Slough often used Elkhorn Slough for their resting area and Monterey Bay for feeding. Tagged seals, however, occasionally used other haul-out sites along the coast, such as Año Nuevo, Hopkins Marine Station, Seal Rock at the 17-mile drive, Point Lobos, Yankee Point, and Point Sur (Fig. 6). All tagged seals eventually returned to Elkhorn Slough. Radio tagged harbor seals fed over the oceanic shelf, along the shelf break of the Monterey submarine canyon, and the mouth of Soquel submarine canyon (Fig. 7). Each seal apparently returned to the same approximate foraging area on consecutive foraging trips (Table 3).

Twenty-eight backpacks were recovered (84.8% recovery rate), and useful data were retrieved from 21 TDRs. Because three seals did not exit Elkhorn Slough while the TDR was attached, the dives from these seals were not analyzed, therefore, analyses were conducted on a total of 16,403 dives recorded for 18 seals (Table 4).

Drag, buoyancy, and weight of a backpack potentially affect diving behavior of a harbor seal. If diving behavior of a harbor seal was hindered by the backpack, depth of dives may change over time. Two possibilities were examined to assess effects of backpacks on diving behavior of harbor seals. Immediately after tagging, the flotation of the backpack may prevent the seal from diving deep but the seal may habituate to the backpack and gradually dive deeper. Alternatively, the depth of dives may become shallower over time from physical exertion caused by additional weight and drag of the backpack. Change in depth of dives of each seal during the TDR deployments, therefore, was investigated (Fig. 8). All dives of each seal outside of Elkhorn Slough were divided into 20 consecutive and equal numbered groups. The mean depth of dives and standard error were calculated for each group. For example, 506 dives were recorded from seal s5486. Average and standard error of every 25 dives (1/20 of 506 dives) were estimated and plotted (Fig. 8). Neither a positive nor negative trend was observed in data from 18 seals. We assumed, therefore, backpacks had negligible effects on diving behavior of harbor seals for the duration of backpack attachment.

No differences between males and females were found in the mean depth of dives (two sample t-test,  $t = 0.958$ ,  $p = 0.352$ , Power  $\approx 15$ ) and the mean duration of dives (two sample t-test,  $t = 0.7178$ ,  $p = 0.483$ , Power  $\approx 10$ ; Table 5). There was a significant positive relationship between the average depth of dives and weight ( $\text{depth (m)} = -84.2 + 1.65 \times (\text{weight (kg)})$ ),  $r^2 = 0.63$ ,  $n = 18$ ,  $p = 0.00009$ ; Fig. 10).

Greater number of dives were recorded between dusk and dawn ( $\bar{x}_{\text{night}} = 573.9$  dives,  $SE = 99.1$ ) than between dawn and dusk ( $\bar{x}_{\text{day}} = 337.3$  dives,  $SE = 58.7$ ,  $\chi^2 = 1451.2$ ,  $df = 17$ ,  $p < 0.001$ ; Table 4). No difference was found in the mean duration of dives ( $\bar{x}_{\text{night}} = 4.92$  min,  $SE_{\text{night}} = 0.51$ ;  $\bar{x}_{\text{day}} = 4.78$  min,  $SE_{\text{day}} = 0.46$ ; paired  $t = -1.398$ ,  $n = 17$ ,  $p = 0.181$ , power = 29; Table 4) or the mean depth of dives ( $\bar{x}_{\text{night}} = 51.46$  m,  $SE_{\text{night}} = 9.58$ ,  $\bar{x}_{\text{day}} = 49.45$  m,  $SE_{\text{day}} = 8.74$ ; paired  $t = -0.951$ ,  $n = 17$ ,  $p = 0.356$ , power = 13; Table 4) between night and day periods.

Dives were deeper during the late summer and early winter than remainder of the year (Fig. 10). Many dives during the early afternoon (1500 to 1800) of late summer and early winter, however, appeared to be shallower than the rest of the year (Fig. 11). Because these data were not independent of each other (multiple depth readings from each seal), no statistical analysis was conducted.

There was a positive non-linear relationship between the maximum depth of dives and the average rate of descent (Fig. 11). Average rate of descent rarely exceeded 2 m/s in dives deeper than 50 m. A non-linear positive relationship was found between the maximum depth of dives and the average rate of ascent (Fig. 12). The average rate of ascent did not exceed 1.5 m/s in most dives deeper than 50 m. There was a positive non-linear relationship between the maximum depth of dives and the duration of dives (Fig. 13). Although the majority of dives were less than 20 minutes, a few dives exceeded 30 minutes (Fig. 13).

Although heart rate monitors were deployed on 19 seals, reasonable data were obtained from only two seals. Heart rate was too variable to conduct meaningful analyses. Heart rates appeared to be less variable but greater while a seal (seal 5306) was at surface for an extended period of time than when the seal was swimming and diving (Fig. 14a). No similar trend was

found in data from seal 5185 (Fig. 14b). Heart rates of seal 5306 ranged from 40 to 120 bpm within a 30-second period while the seal was at the surface, or possibly resting ashore. While the seal was swimming and diving, however, heart rates ranged from close to 0 to 100 bpm (Fig. 14a). Heart rates of seal 5306 ranged from close to 0 to 150 bpm regardless of its activities (Fig. 14b). Heart rates of five harbor seals during the tagging procedure ranged from 110 to 140 bpm.

The playback experiment was scheduled for 29 days during the summer of 1996. Because of weather conditions and locations of tagged seals, however, only 12 trials were attempted. Sound pressure levels of experiments were approximately 120 to 152 dB re  $1\mu\text{Pa}$  at 1m. Experiments were conducted over the nearshore oceanic shelf and Monterey submarine canyon. Seals, however, did not stay offshore and moved into Elkhorn Slough during all experiments, which made it impossible to keep the seal close to the sound source. Therefore, we were unable to test the effects of ATOC-like sounds on the diving behavior and heart rate of harbor seals.

The results of the transmission loss experiments indicated that the M-sequence attenuates rapidly in shallow water. The sound disappeared in the ambient noise within two kilometers from the sound source.

### Discussion

More male harbor seals were captured in Elkhorn Slough than females. If the probability of capturing either sex was equal, more male harbor seals used Elkhorn Slough than females. Sex ratios also have been determined at Hopkins Marine Station (HMS) in Monterey Bay. Although HMS is the closest harbor seal haul-out site to Elkhorn Slough, more females utilize HMS than males (T. Nicholson, pers. comm.). More females are found at HMS than males probably because HMS is near prime pupping sites in the Monterey Bay area, such as Cypress Point and Point

Lobos. The number of new-born pups in Elkhorn Slough has been increasing during the last few years (T. Eguchi, pers. obs.), consequently, the number of female harbor seals may be increasing in Elkhorn Slough. Increase in the number of females captured during early summer indicated possible influx of female harbor seals before the pupping season. Continuous tagging effort and population census in the Monterey Bay area, however, are necessary to test this hypothesis.

Tagged harbor seals in Elkhorn Slough were recaptured opportunistically. Four of the 16 recaptured seals decreased in size between captures. Changes in their physiological status, feeding efficiency, and food availability may have caused the decrease of body weight of harbor seals. One of the four seals was a female, which was tagged during October 1993 and recaptured during August 1994. A possible explanation for the decrease in weight during August 1994 is that the seal gave birth during the early summer of 1994, and was still recovering from parturition, lactation, and annual molt during the summer. Lactation in pinnipeds requires three to six times greater energy output than normal physiological maintenance (Miller 1977, Fedak and Anderson 1982). Female phocids often lose 16 to 46% of their body weight during lactation (Fedak and Anderson 1982, Stewart and Lavigne 1984, Bowen et al. 1987, Tedman and Green 1987, Kovacs et al. 1991, Hammill et al. 1991).

The average positive growth rate of 15.39 kg/yr was comparable to the 12.4 kg/yr growth of a harbor seal (Divinyi 1971; One-sample t-test,  $t = 1.43$ ,  $p = 0.18$ , power = 28). More precise estimates of the growth of harbor seals will be available as more harbor seal pups are tagged along the coast (M. Lander, pers. comm.). Although harbor seals are protected from hunting by the Marine Mammal Protection Act (MMPA, 1972, amended 1988, 1994), the growth estimate is essential to better protect, conserve, and manage the species in the future.

The small number of recaptured seals prohibited us from estimating the population size of harbor seals in Elkhorn Slough. Occasional censuses in Elkhorn Slough, however, indicated approximately 300 harbor seals used the slough during the summer of 1995 (T. Eguchi pers. obs.), which was 1.7 times greater than the maximum count during 1991 (Oxman 1995; maximum count = 180). Additional haul out sites of harbor seals in Elkhorn Slough also indicated increase in the number of harbor seals using the slough. Continuous census efforts in the Monterey Bay area will enable accurate population size estimates of harbor seals.

Quiet and isolated mudflats in Elkhorn Slough provided a suitable habitat for resting harbor seals. Although human activities, such as kayaking and boating, were infrequent in Elkhorn Slough during weekdays, numerous kayaks were observed during weekends (T. Eguchi, pers. obs.). Because kayakers travel closer to shore and may harass harbor seals at a greater distance than power boats (Calambokidis et al. 1991), there is a potential negative effect of kayakers on harbor seals ashore. Researchers demonstrated that fewer harbor seals returned to haul-out sites than the original number after a disturbance (Allen et al. 1984, Suryan 1995). Additional studies are necessary to assess effects of increasing human activities on harbor seals in Elkhorn Slough and adjacent areas.

Harbor seals in Elkhorn Slough generally came ashore during daytime, which was consistent with previous studies (Boulva and MacLaren 1979, Stewart 1984, Yochem et al. 1987, Oxman 1995, Trumble 1995). Although Oxman (1995) reported harbor seals in Elkhorn Slough did not rest ashore nocturnally, harbor seals were seen ashore in Elkhorn Slough at night and radio-tagged seals also were located ashore at night in Elkhorn Slough. Oxman (1995) may not have observed nocturnal haul-out behavior because he only tagged seven harbor seals, and his sample of all subadult seals may not be representative.

Oxman (1995) indicated harbor seals in Elkhorn Slough returned to the slough every day indicating greater site fidelity than harbor seals in other areas (Allen et al. 1987, Thompson et al. 1989). During our study, however, five seals were away from the slough for as long as 10 days. Seals were located at haul-out sites as far as approximately 80 km from the slough (Fig. 6). All seals eventually returned to Elkhorn Slough and exhibited similar site fidelity as harbor seals observed in other areas (Divinyi 1971, Knudtson 1974, Reijnders 1976, Boulva and MacLaren 1979, Stewart and Yochem 1983).

Oxman (1995) and Trumble (1995) reported harbor seals in the Monterey Bay area frequently foraged off Sunset Beach. Results of our study, however, indicated harbor seals frequently visited submarine canyons and areas over the oceanic shelf, as well as the area off Sunset Beach. Nine seals made more than one dive deeper than 200 m, indicating these seals dove in submarine canyons and along sea cliffs. The bottom topography of these locations may create nutrient rich conditions resulting in high productivity of the area. Greater numbers of juvenile rockfish (K. Johnson, pers. comm.), cetaceans (Dorfman 1991, S. Benson, pers. comm.), and sea birds (S. Benson, pers. comm.) have been found where harbor seals commonly foraged.

Harbor seals are opportunistic carnivores feeding on seasonally abundant cephalopods and fishes (Brown and Mate 1983, Harvey 1987, Harkonen and Heide-Jorgensen 1991, Olesiuk 1993, Torok 1994, Harvey et al. 1995, Oxman 1995, Trumble 1995). Food habits of harbor seals in Monterey Bay change throughout the year as abundance of prey items change in the bay. Octopus (*Octopus* sp.) was the dominant prey item of harbor seal during autumn and winter, but was significantly less important during summer (Oxman 1995, Trumble 1995). Harbor seals mainly ate juvenile rockfish (*Sebastes* sp.), the market squid (*Loligo opalescens*), the white croaker (*Genyonemus lineatus*), and octopi during spring and summer (Oxman 1995, Trumble

1995). Diving behavior of harbor seals appeared to reflect this change in food habits as the depth of dives increased during late autumn and winter. Depth of dives decreased during spring and summer coinciding with inshore movements of juvenile rockfishes (Cailliet et al. 1979) and white croaker (Wang 1986).

Continuous dive records indicated harbor seals followed the bottom contour as they traveled between Elkhorn Slough and their feeding sites. Similar results were reported for northern elephant seals (Le Boeuf et al. 1988). There are two possible explanations for the bottom swimming behavior: (1) predator avoidance, such as the white shark (*Calcharodon carcharias*) and the killer whale (*Orcinus orca*), and (2) navigation. Because TDR records indicated seals dove to the same depth in consecutive foraging trips (Fig. 15) and seals consistently foraged in the same areas, harbor seals may use bottom topography for navigation in the bay, returning to the same feeding area in consecutive feeding trips.

Many dives within a feeding trip were of similar maximum depths. Seals dove to a certain depth and remained at the depth until ascending to the surface (Fig. 16). This pattern indicated that after locating a prey patch, seals repeatedly dove to the patch. Croll et al. (1992) reported a similar diving behavior by the Thick-billed Murre (*Uria lomvia*) at Coats Island, Northwest Territories, Canada.

Unlike studies on other diving animals, the depth of dives of harbor seals in Monterey Bay did not differ between day and night. Feldkamp et al. (1989) reported the depth of dives of California sea lions off San Miguel Island became shallower as the night progressed. They attributed the change in depth of dives to the vertical migration of prey. Gentoo Penguins (*Pygoscelis papua*) made significantly shallower dives between dawn and dusk than midday, which corresponded to vertical movements of Antarctic krill (*Euphausia superba*; Williams et al.

1992). Harbor seals in Monterey Bay did not change the maximum depth of dives between day and night probably because harbor seals mainly fed on benthic fish and octopi that did not migrate vertically.

Although no difference was found in the mean depth or duration of dives between males and females, power of the analyses were low. Differences in the diving behavior of males and females have been reported for the northern elephant seal (Le Boeuf et al. 1989, DeLong and Stewart 1991) and the southern elephant seal (*Mirounga leonina*; Hindell et al. 1991). Female southern elephant seals potentially fed on pelagic prey, whereas males foraged on benthic and pelagic prey. Because of patchy prey distributions in the marine environment, partitioning of prey and foraging areas may reduce competition between sexes and among age classes.

A significant positive relationship was found between the average depth and duration of dives, and the weight of seals (Fig. 10). Harbor seals in Monterey Bay may have partitioned feeding areas among size classes. Because the difference in the body sizes of males and females is small in harbor seals (King 1983, Reeves et al. 1992), differences in diving patterns among size classes may be more apparent than the difference between sexes. The maximum duration of dives in pinnipeds are restricted by the amount of stored oxygen and oxygen consumption rate (Kooyman et al. 1983). Most oxygen in the body is stored in blood and muscles (Schmidt-Nielsen 1983), and oxygen consumption rates of many mammals are logarithmically related to their body mass ( $V_{O_2} = 0.676 \times M_b^{0.75}$ , where  $V_{O_2}$  = oxygen consumption, and  $M_b$  = body mass; Schmidt-Nielsen 1983). The maximum duration of dives, therefore, should be greater for large animals than small animals. Large seals may search for their food in deeper waters thus avoiding intra-specific competition.

Heart rate was more variable while seals were swimming and diving than when resting. Previous researchers indicated seals and sea lions reduce their heart rates while swimming and diving (Fedak et al. 1988, Ponganis et al. 1990, Williams et al. 1991, Butler et al. 1992). Although the range of heart rates in this study (0 to 140 bpm while the seal was swimming and diving) was greater than previous studies (35 to 140 bpm; Fedak et al 1988), the difference may be due to age classes studied, depth of dives, and sampling rates.

The sampling rate for heart rates affected the precision of data. Continuous monitoring of an electrocardiogram is the most precise method to monitor heart rates. Inter-beats intervals can be used to assess changes in heart rate (Kooyman and Campbell 1972, Fedak et al. 1988, Williams et al. 1991). The use of an electrocardiogram, however, is limited to laboratory experiments and specific environments. Researchers must be present near the animal to obtain data through an electrocardiogram (Kooyman and Campbell 1972, Fedak et al. 1988). Consequently, most heart rate data from wild animals were obtained by averaging heart rates for a known period (e.g. Kooyman et al. 1992). When data were averaged during a certain period, behavior of the animal greatly affected the precision of the data. For example, if an animal surfaces for less than 20 seconds and data were recorded every 30 seconds, there is a great chance of averaging heart rates for two distinct behaviors (i.e. diving and breathing), resulting in an over- or under-estimation of heart rates at the surface. During this study, we used a 30-second interval to collect heart rate data. The interval may have been too long because harbor seals spent 30 to 60 seconds at the water surface while they foraged offshore.

There are several possible reasons for the failure of heart rate monitors. Because seals were not anesthetized during tag deployment, a limited amount of time was available to deploy electrodes and TDRs. Inadequate sealing of electrodes may have caused a leak during dives,

disabling electrodes so heart rate could not be detected. Most studies of heart rates of diving animals with surface-mounted electrodes were conducted in laboratory tanks (Bacon et al. 1985, Ponganis et al. 1990, Williams et al. 1991). Only a few researchers have used successfully surface-mounted electrodes to detect heart rates of free-ranging pinnipeds (Fedak et al. 1988). Fletcher et al. (1995) demonstrated the possibility of using an acoustic recording device to record heart rates of northern elephant seals. Subcutaneous electrodes may provide more reliable data. A more precise and robust technique is necessary to precisely estimate changes in heart rates of diving animals.

Although we were unable to directly test the effects of the ATOC sound on harbor seals, harbor seals in Monterey Bay are unlikely to be affected by the ATOC sound source. Harbor seals inhabit coastal shallow waters (< 200m), where four primary sound sources dominate ambient noise: (1) distant shipping, industrial, or seismic-survey noise, (2) wind and wave noise, (3) biological noise, and (4) breaking surf at the beach (Willson et al. 1985, Greene 1995a). Results of playback experiments indicated the M-sequence in the shallow water disappeared in the ambient noise within two kilometers of the sound source. Harbor seals in Monterey Bay probably cannot detect the sound from the ATOC sound source off Pillar Point. Even if harbor seals could hear the ATOC sound source, the pressure level of the sound in Monterey Bay would not be great enough to alter their behavior or physiological status.

If harbor seals near the ATOC sound source dove to the maximum depth of dives recorded during this study ( $\approx 500\text{m}$ ), harbor seals could detect the ATOC sound. During aerial surveys conducted by the ATOC Marine Mammal Research Program, however, harbor seals were not found within 40 km of the ATOC sound source (J. Calambokidis, Cascadia Research, pers. comm.). Assuming the ATOC sound spreads spherically to 850 m from the sound source (i.e. the

depth of the sound source), and a "15logR" spreading loss thereafter, the sound pressure of the ATOC sound would be approximately 111 dB re 1 $\mu$ Pa at 40 km from the source. Although biological and physiological effects of the 110-dB ATOC sound on harbor seals are unknown, it is unlikely that harbor seals are negatively affected by this noise. Because harbor seals inhabit coastal waters, harbor seals are constantly exposed to a variety of loud underwater noises, including boats, ships, breaking surf, and wind and wave noises. An additional underwater noise is unlikely to alter behavior and physiological status of harbor seals. Because harbor seals are opportunistic predators and highly mobile, seals would swim away from the ATOC sound source if the sound pressure was intolerable in their feeding areas. Continuous census and tagging efforts will help understand long-term effects of man-made noise on harbor seals.

### Conclusions

More male harbor seals used Elkhorn Slough than females. The number of females in Elkhorn Slough, however, increased during late spring, before the pupping season. The average growth rate of harbor seals in Elkhorn Slough was 6.8 kg/yr. The number of harbor seals in Elkhorn Slough apparently is increasing annually. Harbor seals occasionally made long distance movements, one was 10 days and approximately 80 km. Harbor seals foraged in submarine canyons, areas over the oceanic shelf, and along the sea cliff in Monterey Bay, coinciding with movements of prey. Harbor seals appeared to swim along the bottom in Monterey Bay between Elkhorn Slough and their foraging areas. No difference in the maximum depth of dives between day and night was observed in harbor seals in Monterey Bay. Larger seals appeared to dive longer and deeper indicating a possible partitioning of foraging areas within the species. We concluded it was unlikely that the ATOC sound source had any effect on harbor seals in the

Monterey Bay area. Continuous tagging and census studies, however, should be conducted to better understand the harbor seal population in the area.

### Literature Cited

- Allen, S. G. 1991. Harbor seal habitat restoration at Strawberry Spit, San Francisco Bay. Point Reyes Bird Observatory. 47pp.
- Allen, S. G., D. G. Ainley, G. W. Page, and C. A. Ribic. 1984. The effect of disturbance on harbor seal haul out patterns at Bolinas Lagoon, California. *Fishery Bulletin* 82:493-500.
- Allen, S. G., D. G. Ainley, L. Fancher, and D. Shufford. 1987. Movement and activity patterns of harbor seals (*Phoca vitulina*) from the Drakes Estero population, California, 1985-1986. NOAA Technical Memorandum. NOS MEMD 6. 35pp.
- Anderson, D. W. and R. W. Risebrough. 1976. Brown Pelican reproduction: letters to the editor. *Science* 193: 96-97.
- Awbrey, F. T. and B. S. Stewart. 1983. Behavioral responses of wild beluga whales (*Delphinapterus leucus*) to noise from oil drilling. *Journal of Acoustic Society of America*, Supplement 1.74:S54 (Abstract)
- Bacon, J. P., R. S. Mackay, H. E. Cohn, and A. F. S. Lee. 1985. Development of a bimodal heart rate pattern in undisturbed fetal harbor seals. *Marine Mammal Science* 1(4): 294-303.
- Boulva, J. and I. A. MacLaren. 1979. Biology of the harbor seal, *Phoca vitulina*, in eastern Canada. *Journal of Fishery Research Board of Canada*, Bulletin No. 200, 24pp.
- Bowen, W. E., E. J. Bonness, and O. T. Oftedal. 1987. Weight transfer from mother to pup and subsequent weight loss by the weaned pup in the hooded seal, *Cystophora cristata*. *Canadian Journal of Zoology*. 65: 1-8.
- Brown, R. F. and B. R. Mate. 1983. Abundance, movements, and feeding habits of harbor seals, *Phoca vitulina*, at Netarts and Tilamook Bays, Oregon. *Fishery Bulletin*. 81: 291-301.
- Brueggeman, J. J., R. A. Grotefendt, M. A. Smultea, G. A. Green, R. A. Rowlett, C. C. Swanson, D. P. Volsen, C. E. Bowlby, C. I. Malme, R. Mlawski, and J. J. Burns. 1992. 1991 Marine mammal monitoring program (walrus and polar bear). Crackerjack and Diamond prospects Chukchi Sea. Report from EBASCO Environmental, Bellevue, WA, for Shell Western E & P Inc. and Chevron U.S.A.

- Butler, P. J., A. J. Woakes, I. L. Boyd, and S. Kanatous. 1992. Relationship between heart rate and oxygen consumption during steady-state swimming in California sea lions. *Journal of Experimental Biology*. 170: 35-42.
- Cailliet, G., K.A. Kaprov, and D. A. Ambrose. 1979. Pelagic assemblages as determined from purse seine and large midwater trawl catches in Monterey Bay and their affinities with market squid (*Loligo opalescens*). CALCOFI Report Vol. XX. 1979: 21-30.
- Calambokidis, J., G. H. Steiger, J. R. Evans, and S. J. Jeffries. 1991. Censuses and disturbance of harbor seals at Woodard Bay and recommendations for protection. Final Report to Washington department of Natural Resources, Olympia, Washington. 45pp.
- Cosens, S. E. and L. P. Dueck. 1993. Ice breaker noise in Lancaster Sound, N.W.T., Canada: Implications for marine mammal behavior. *Marine Mammal Science* 9(3): 285-300.
- Croll, D. A., A. G. Gaston, A. E. Burger, and D. Konnoff. 1992. Foraging behavior and physiological adaptation for diving in Thick-billed Murres. *Ecology*. 73(1): 344-356.
- Dahlheim, M. E. and H. D. Fisher. 1983. Responses of gray whales (*Eschrichtius robustus*) to nonbiological noise. *Journal of Acoustic Society of America*, Supplement 1. 74:S54-S55 (Abstract)
- DeLong, R. L. and B. S. Stewart. 1991. Diving patterns of northern elephant seal bulls. *Marine Mammal Science*. 7(4): 369-384.
- Divinyi, C. A. 1971. Growth and movements of a known-age harbor seal. *Journal of Mammalogy*. 52(4): 824.
- Dorfman, E. 1991. Distribution, behavior, and food habits of harbor porpoise, *Phocena phocena*, in Monterey Bay, California. MA Thesis, Moss Landing Marine Laboratories. 48 pp.
- Dorrance, M. J., P. J. Savage, and D. E. Huff. 1975. Effects of snowmobiles on white-tailed deer. *Journal of Wildlife Management*. 39: 563-569.
- Fedak, M. A. and S. S. Anderson. 1982. The energetics of lactation: accurate measurements from a large wild mammal, the grey seal (*Halichoerus grypus*). *Journal of Zoology (Lond.)* 198: 473-479.
- Fedak, M. A., M. R. Pullen, and J. Kanwisher. 1988. Circulatory responses of seals to periodic breathing: heart rate and breathing during exercise and diving in the laboratory and open sea. *Canadian Journal of Zoology*. 66: 53-60.
- Feldkamp, S. D., R. L. DeLong, and G. A. Antonelis. 1989. Diving patterns of California sea lions, *Zalophus californianus*. *Canadian Journal of Zoology*. 67: 872-883.

- Fletcher, S, B. J. Le Boeuf, D. P. Costa, and P. Tyack. 1995. Onboard acoustic recording from diving elephant seals. Abstract. Eleventh Biennial conference on the Biology of Marine Mammals. 14-18 December 1995. Orlando, FL, U.S.A.
- Greene, C. R. Jr. 1995a. Ambient Noise. In. Marine Mammals and Noise. Richardson, W. J. et al. (Eds.) Academic Press.
- Greene, C. R. Jr. 1995b. Man-made Noise. In. Marine Mammals and Noise. Richardson, W. J. et al. (Eds.) Academic Press.
- Hammill, M. O., C. Lydersen, M. Ryg, and T. G. Smith. 1991. Lactation in the ringed seal (*Phoca hispida*). Canadian Journal of Fishery and Aquatic Sciences 48: 2471-2476.
- Hanan, D. A., L. M. Jones, and M. J. Beeson. 1993. Harbor seal, *Phoca vitulina*, census in California, May-June, 1992. Final Report. NOAA fisheries/NMFS Southwest Region.
- Harkonen, T. and M. P. Heide-Jorgensen. 1991. The harbour seal, *Phoca vitulina*, as a predator in the Skagerrak. Ophelia 34(3): 191-207.
- Harvey, J. T. 1987. Population dynamics, annual food consumption, movements, and dive behaviors of harbor seals, *Phoca vitulina*, in Oregon. Ph.D. dissertation, Oregon State University. 177pp.
- Harvey, J. T., R. C. Helm, and G. V. Morejohn. 1995. Food habits of harbor seals, *Phoca vitulina*, inhabiting Elkhorn Slough, Monterey Bay California. California Fish and Game. 81(1): 1-9.
- Hindell, M. A., D. J. Slip, and H. R. Burton. 1991. The diving behavior of adult male and female southern elephant seals, *Mirounga leonina* (Pinnipedia : Phocidae). Australian Journal of Zoology. 39: 595-619.
- Jefferies, S., R. Brown, and J. T. Harvey. 1993. Techniques for capturing, handling and marking harbour seals. Aquatic Mammals. 19.1:21-25.
- Johnson, B. W. 1977. The effects of human disturbance on a population of harbor seals. Environmental Assessment in Alaskan Continental Shelf, Annual Report. NOAA, Boulder, CO, 1977(1): 422-432.
- Jordan, R. E. and J. R. Payne. 1980. Fate and weathering of petroleum spills in the Marine Environment. Ann Arbor Science Publishers, Inc. Ann Arbor, Michigan. 174pp.
- Kastak, D. 1996. Comparative aspects of hearing in pinnipeds. Ph.D. Dissertation. University of California, Santa Cruz.

- Keay, J. A. 1995. Black bear reproduction rates in Yosemite National Park. California Fish and Game 81(3): 122-131.
- King, J. E. 1983. Seals of the World. Cornell University Press. 240 pp.
- Knudtson, P. M. 1974. Mother-pup behavior within a pupping colony of harbor seals (*Phoca vitulina*) in Humbolt Bay, California. M.S. Thesis, California State University, Humbolt. 42pp.
- Kovacs, K. M., D. M. Lavigne, and L. Innes. 1991. Efficiency of weight transfer by lactating harp seals, *Phoca groenlandica*. Journal of Zoology (Lond.) 223: 213-221.
- Kooyman, G. L. and W. B. Campbell. 1972. Heart rates in freely diving Weddell seals, *Leptonychotes weddelli*. Comparative Biochemistry and Physiology. 43A: 31-36.
- Kooyman, G. L., M. A. Castellini, R. W. Davis, and R. A. Maue. 1983. Aerobic dive limits in immature Weddell seals. Journal of Comparative Physiology B. 151: 171-174.
- Kooyman, G. L., P. J. Ponganis, M. A. Castellini, E. P. Ponganis, K. V. Ponganis, P. H. Thorson, S. A. Eckert, and Y. Lemaho. 1992. Heart rates and swim speeds of Emperor Penguins diving under sea ice. Journal of Experimental Biology. 165: 161-180.
- Le Boeuf, B. J., D. P. Costa, A. C. Huntley, and S. D. Feldkamp. 1988. Continuous, deep diving in female northern elephant seals, *Mirounga angustirostris*. Canadian Journal of Zoology. 66: 446-458.
- Le Boeuf, B. J., Y. Naito, A. C. Huntley, and T. Asaga. 1989. Prolonged, continuous, deep diving by northern elephant seals. Canadian Journal of Zoology. 67: 2514-2519.
- Miller, J. S. 1977. Adaptive features of mammalian reproduction. Evolution 31: 370-386.
- Myrberg, A. A, Jr. 1990. The effects of man-made noise on the behavior of marine animals. Environmental International. 16:575-586.
- Møhl, B. 1968. Auditory sensitivity of the common seal in air and water. The journal of Auditory Research. 8: 27-38.
- NOAA-CNEXO. 1982. Ecological study of the Amoco Cadiz oil spill. U.S. Department of Commerce. National Oceanic and Atmospheric Administration. 479pp.
- Norris, T. F. 1995. Effects of boat noise on the singing behavior of humpback whales (*Megaptera novaeangliae*). M. S. Thesis. San Jose State University and Moss Landing Marine Laboratories.
- Olesiuk, P. F. 1993. Annual prey consumption by harbor seals (*Phoca vitulina*) in the Strait of Georgia, British Columbia. Fishery Bulletin 91: 491-515.

- Oxman D. S. 1995. Seasonal abundance, movements, and food habits of harbor seals (*Phoca vitulina richardsi*) in Elkhorn Slough, California. M.S. Thesis. California State University, Stanislaus and Moss Landing Marine Laboratories.
- Ponganis, P. J., G. L. Kooyman, H. H. Zornow, M. A. Castellini, and D. A. Croll. 1990. Cardiac output and stroke volume in swimming harbor seals. *Journal of Comparative Physiology B*. 160: 473-482.
- Reeves, R., B. S. Stewart, and L. Leatherwood. 1992. *The Sierra Club hand book of seals and sirenians*. Sierra Club Books, San Francisco, California. 359 pp.
- Reijnders, P. J. H. 1976. The harbour seal (*Phoca vitulina*) population in the Dutch Wadden Sea: size and composition. *Netherlands Journal of Sea Research* 10: 223: 235.
- Schmidt-Nielsen, K. 1983. *Animal Physiology: Adaptation and environment*. Cambridge University Press. 619 pp.
- Spreadbury, B. R., K. Musil, J. Musil, C. Kaisner, and J. Kovak. 1996. Cougar population characteristics in southeastern British Columbia. *Journal of Wildlife Management* 60(4): 962-969.
- Stephenson, T. R. M. R. Vaughan, and D. E. Andersen. 1996. Mule deer movements in response to military activity in southeast Colorado. *Journal of Wildlife Management*. 60(4): 777-787.
- Stewart, B. S. 1984. Diurnal hauling patterns of harbor seals at San Miguel Island, California. *Journal of Wildlife Management*. 48: 1459-1461.
- Stewart, B. S. and P. K. Yochem. 1983. Radiotelemetry studies of hauling patterns, movements, and site fidelity of harbor seals (*Phoca vitulina richardsi*) at San Nicholas and San Miguel Islands, California, 1982. Hubbs-Sea World Research Institute, Technical Report. 83-152: 1-56.
- Stewart, R. E. A. and D. M. Lavigne. 1984. Energy transfer and female condition in nursing harp seals *Phoca groenlandica*. *Holarctic Ecology*. 7: 182-194.
- Suryan, R. M. 1995. Pupping phenology, disturbance, movements, and dive patterns of the harbor seal (*Phoca vitulina richardsi*) off the northern San Juan islands of Washington. M.S. Thesis. San Jose State University and Moss Landing Marine Laboratories. 75pp.
- Tedman, R. And B. Green. 1987. Water and sodium fluxes and lactational energetics in suckling pups of Weddell seals, (*Leptonychotes weddelli*). *Journal of Zoology (Lond.)* 212: 29-42.
- Terhune, J. M., R. E. A. Stewart, and K. Ronald. 1979. Influence of vessel noises on underwater vocal activity of harp seals. *Canadian Journal of Zoology*. 57:1337-1338.

- Thompson, P. M., M. A. Fedak, B. J. McConnell, and K. S. Nicholas. 1989. Seasonal and sex-related variation in the activity patterns of common seals (*Phoca vitulina*). *Journal of Applied Ecology*. 26: 521-535.
- Torok, M. L. 1994. Movements, daily activity patterns, dive behavior, and food habits of harbor seals (*Phoca vitulina richardsi*) in San Francisco Bay, California. M.S. Thesis, Moss Landing Marine Laboratories and California State University at Stanislaus. 88pp.
- Townsend, R. And B. Heneman. 1989. The Exxon Valdez oil spill: A management analysis. Center for Marine Conservation, Washington D.C. 239pp.
- Trumble, S. J. 1995. Abundance, movements, dive behavior, food habits, and mother-pup interactions of harbor seals (*Phoca vitulina richardsi*) near Monterey Bay, California. M.S. Thesis, Moss Landing Marine Laboratories and California State University at Fresno.
- Van Dyke, F. and W. C. Klein. 1996. Response of elk to installation of oil wells. *Journal of Mammalogy*. 77(4): 1028-1041.
- Wang, J. C. S. 1986. Fishes of the Sacramento-San Joaquin Estuary and adjacent waters, California. A guide to the early life histories. Interagency ecological study program for the Sacramento-San Joaquin Estuary. Technical Report, 9. 323pp.
- Weisenberger, M. E., P. R. Krausman, M. C. Wallace, D. W. De Young, and O. E. Maughan. 1996. Effects of simulated jet aircraft noise on heart rate and behavior of desert ungulates. *Journal of Wildlife Management*. 60(1): 52-61.
- Williams, T. D., A. Kato, J. P. Croxall, Y. Naito, D. R. Briggs, S. Rodwell, and T. R. Barton. 1992. Diving pattern and performance in nonbreeding Gentoo Penguins (*Pygoscelis papua*) during winter. *The Auk*, 109(2): 223-234.
- Williams, T. M., G. L. Kooyman, and D. A. Croll. 1991. The effect of submergence on heart rate and oxygen consumption of swimming seals and sea lions. *Journal of Comparative Physiology B* 160: 637-644.
- Willson, O. B. Jr., S. N. Wolf, and F. Ingenito. 1985. Measurements of acoustic ambient noise in shallow water due to breaking surf. *Journal of Acoustic Society of America*. 78(1): 190-195.
- Yochem, P. K., B. S. Stewart, R. L. DeLong, and D. P. Demaster. 1987. Diel haul-out patterns and site fidelity of harbor seals (*Phoca vitulina richardsi*) on San Miguel Island, California in Autumn. *Marine Mammal Science*. 3: 323-332.

Table 1. The number of tagging sessions conducted per month and the number of male and female seals captured in each month between September 1991 and November 1996 in Elkhorn Slough, CA. Numbers in parentheses indicate the number of males (left) and females (right). Data from 1991 were obtained from Oxman (1995).

Month	Jan.	Feb.	March	April	May	June	July	Aug.	Sept.	Oct.	Nov.	Dec.	Total
Number attempted	2	2	0	1	1	2	2	3	3	4	3	0	23
1991									2 (3, 5)				2
1993										1 (8, 3)			(3, 5) 1
1994						1 (1, 2)	1 (6, 5)	2 (6, 10)		2 (15, 1)	1 (4, 1)		(8, 3) 7
1995	1 (5, 0)	1 (6, 1)		1 (4, 4)		1 (1, 5)	1 (3, 3)	1 (11, 2)					(32, 19) 6
1996	1 (2, 1)	1 (5, 1)			1 (6, 7)				1 (11, 4)	1 (6, 5)	2 (0, 5)		(30, 15) 7
Total Captured	8 (7, 1)	13 (11, 2)		8 (4, 4)	13 (6, 7)	9 (2, 7)	17 (9, 8)	29 (17, 12)	23 (14, 9)	38 (29, 9)	10 (4, 6)		168 (103, 65)

**Table 2.** Mean standard length, axillary girth, and body weight of harbor seals captured in Elkhorn Slough, CA from June 1994 to November 1996.

	Male	Female
Mean standard Length (cm)	131.8	124.2
SE	2.51	2.41
n	89	56
Mean axillary girth (cm)	97.1	93.0
SE	2.18	2.14
n	80	52
Mean body weight (kg)	63.5	51.4
SE	3.02	2.79
n	90	57

**Table 3.** The number of visits to three common feeding areas by 13 radio-tagged harbor seals in Monterey Bay between June 1994 and December 1996. Only seals that returned to a same feeding area were included.

Seal ID number	Along the Sunset Beach, within 1 mile from the shore	Off Sunset Beach, greater than 1 mile from the shore	Monterey submarine canyon
5205			5
5065	2		
5120	4		
5517		2	2
5213		3	
5145	3		
5875	2		
5332			4
5306			2
5545	2		
5315	9		
5273	7		
5160		6	

**Table 4.** Sex, date tagged, standard length, axillary girth, weight, number of dives, mean and standard error of depth of dives, and mean and standard error of duration of dives of 18 harbor seals captured in Elkhorn Slough, California between August 1994 and October 1996.

Seal ID number	Sex	Date tagged	Standard Length (cm)	Axillary Girth (cm)	Weight (kg)	Number of dives	Mean depth during day (SE) (m)	Mean depth during night (SE) (m)	Mean duration during day (SE) (min)	Mean duration during night (SE) (min)
s5213	F	8/16/94	134.0	104.0	58.1	300 (793)	12.0 (0.09)	13.0 (0.04)	3.1 (0.01)	3.1 (0.003)
s5490	M	10/6/94	167.0	128.0	119.3	515 (562)	103.9 (20.6)	106.8 (19.5)	7.1 (0.03)	7.98 (0.03)
s5028	M	10/13/94	151.0	113.0	86.6	361 (147)	82.8 (6.51)	80.4 (10.18)	5.5 (0.014)	6.0 (0.031)
s5403	M	11/18/94	146.0	101.0	62.8	281 (161)	18.8 (1.59)	20.3 (0.183)	3.4 (0.04)	3.4 (0.006)
s5425	M	1/1/95	154.0	121.0	91.4	59 (80)	60.4 (12.3)	56.2 (13.1)	6.5 (0.08)	6.1 (0.07)
s5517	M	1/1/95	145.0	105.5	77.1	341 (899)	22.9 (4.8)	22.0 (2.1)	2.91 (0.016)	2.84 (0.0065)
s5140	M	2/24/95	162.0	117.0	98.4	0 (43)	-	89.1 (92.3)	-	8.25 (0.2)
s5332	F	4/13/95	126.0	106.0	66.9	374 (793)	65.6 (3.1)	58.0 (1.24)	4.9 (0.007)	4.7 (0.003)
s5486	F	7/20/95	130.5	102.0	62.6	15 (491)	5.0 (0.41)	5.1 (0.01)	2.2 (0.11)	2.3 (0.003)
s5875	M	8/24/95	137.0	102.0	61.2	307 (1224)	6.1 (0.07)	6.2 (0.02)	2.9 (0.02)	2.9 (0.005)
s5596	M	1/3/96	152.0	119.5	86.2	163 (240)	30.4 (3.3)	25.9 (1.4)	4.7 (0.04)	4.2 (0.02)
s5306	M	2/28/96	155.0	113.5*	109.8	47 (107)	94.6 (196.4)	114.1 (101.1)	8.0 (0.4)	8.5 (0.19)
s5185	F	5/3/96	157.0	124.0	88.9	700 (598)	71.7 (1.6)	61.6 (1.9)	6.6 (0.01)	6.7 (0.013)
s5145	M	9/12/96	146.0	108.0	73.0	624 (1146)	84.9 (4.42)	92.4 (2.58)	5.6 (0.009)	5.7 (0.005)
s5276	M	9/17/96	143.0	109.0	73.7	511 (458)	17.1 (0.26)	14.8 (0.24)	2.5 (0.003)	2.5 (0.005)
s5065	M	9/17/96	146.0	101.0	80.7	321 (280)	20.5 (0.38)	19.5 (0.41)	2.7 (0.005)	2.7 (0.005)
s5595	F	10/9/96	139.0	102.9*	83.5	925 (977)	37.5 (2.41)	58.2 (2.81)	5.2 (0.01)	6.2 (0.009)
s5205	M	10/9/96	149.0	109.5*	101.2	481 (1332)	106.5 (16.7)	120.3 (16.4)	7.5 (0.025)	7.8 (0.009)

\* Axillary girth of seals s5306, s5595, and s5205 were estimated using a regression equation (girth = 10.858 + 0.662 x length,  $r^2 = 0.791$ ), which was obtained from data collected from 148 harbor seals captured and measured in Elkhorn Slough.

**Table 5.** Average depth and duration, and their standard errors (SE), sample size (n), and minimum and maximum values of dives of 17 harbor seals tagged in Elkhorn Slough, California between August 1994 and October 1996. Seal 5140 was excluded from the analysis because no data were recorded during day.

Sex	Male	Female
Average Depth (m)	56.8	38.5
SE	10.57	13.57
n	12	5
Minimum - Maximum	6.1 - 120.3	5.0 - 71.7
Average Duration (min)	5.19	4.42
SE	0.60	0.78
n	12	5
Minimum-Maximum	2.5 - 8.5	2.2 - 6.7

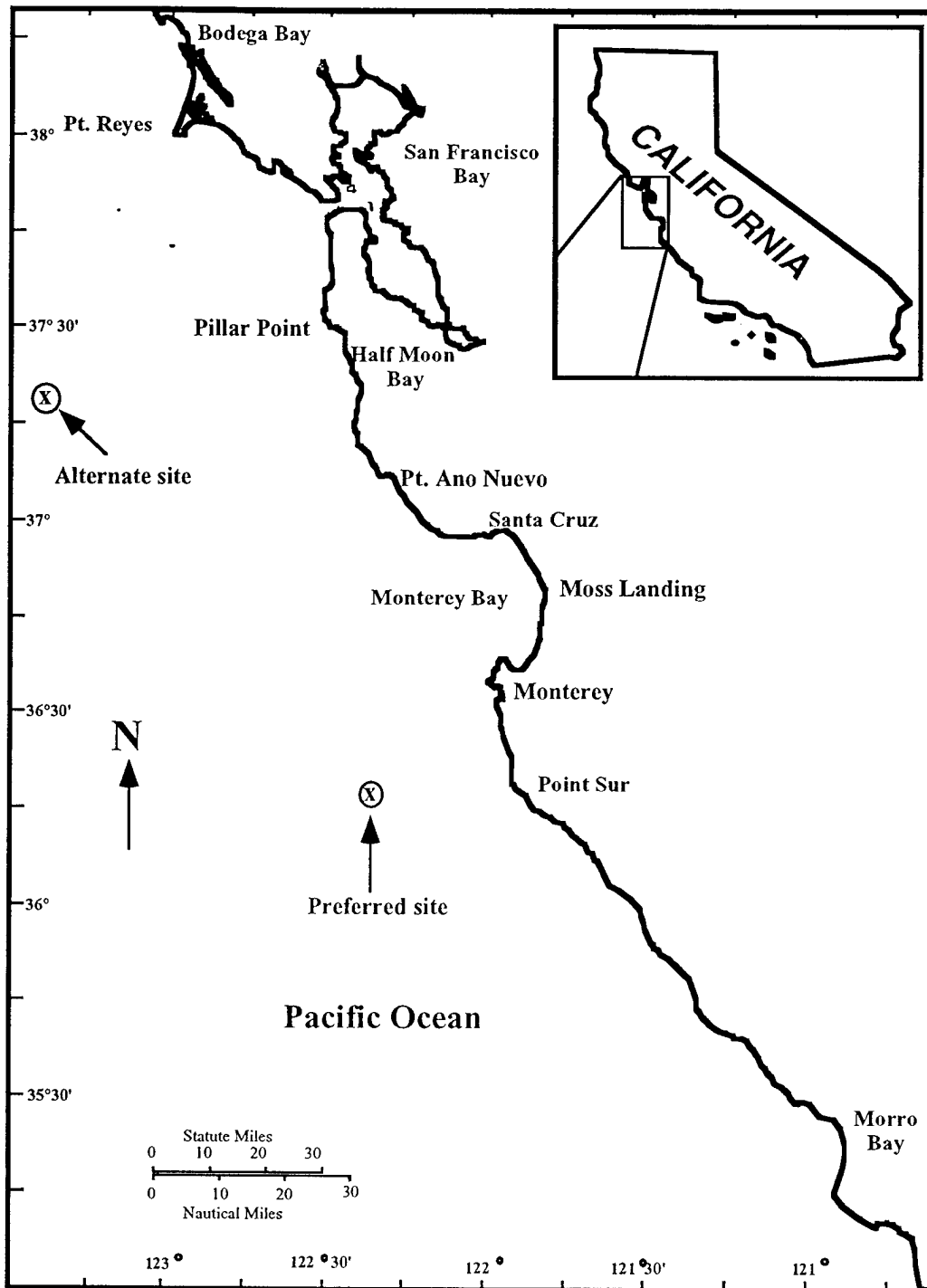

Figure 1. Preferred and alternate ATOC sites.

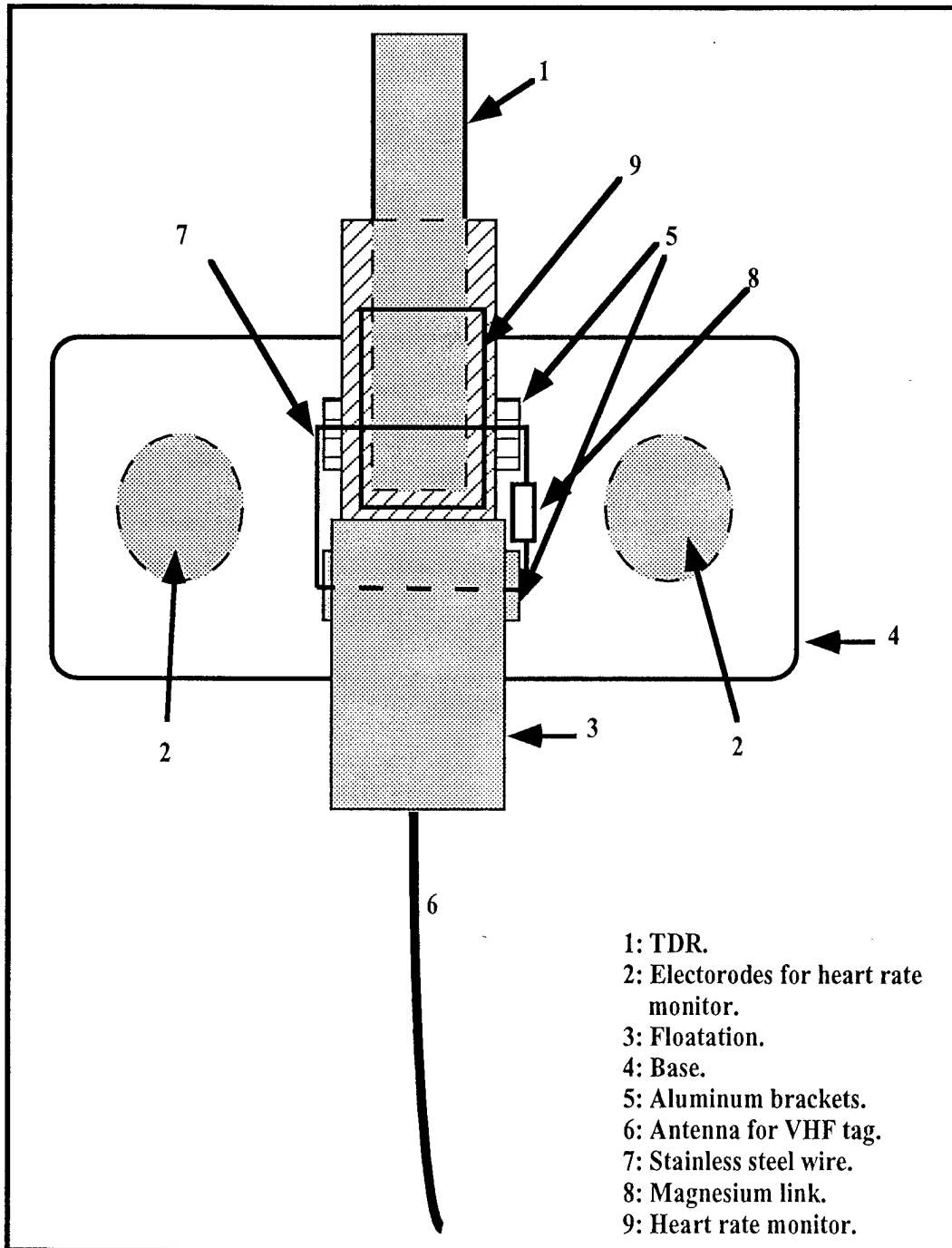

Figure 2. The dorsal view of a backpack and its attachment. The base was glued to the dorsal pelage using instant adhesive. The backpack was secured to aluminum brackets via a stainless steel cable (1/32" diameter). A magnesium link connected the ends of the cable. The Mg link corroded in sea water releasing the backpack within a few days to a month.

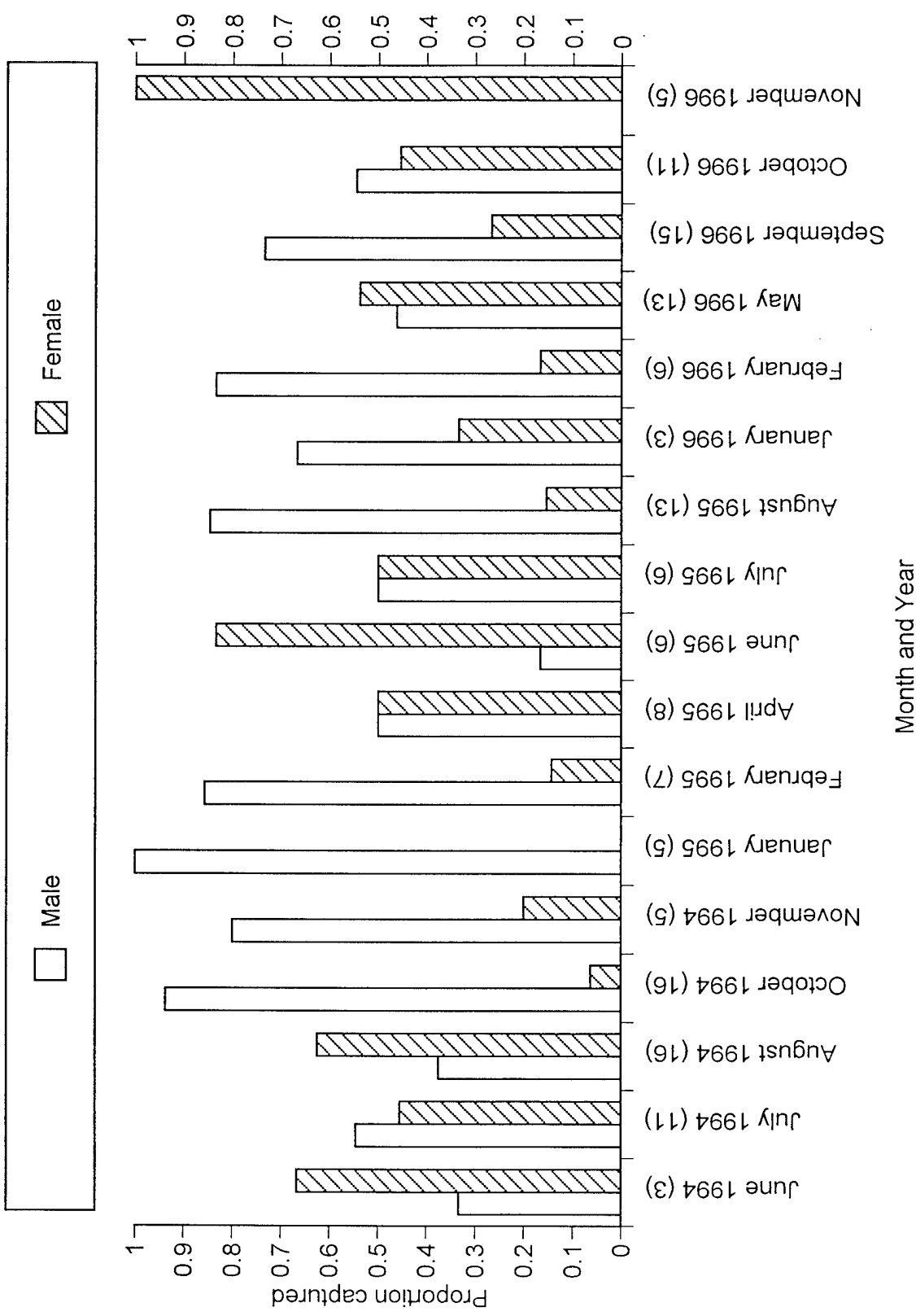
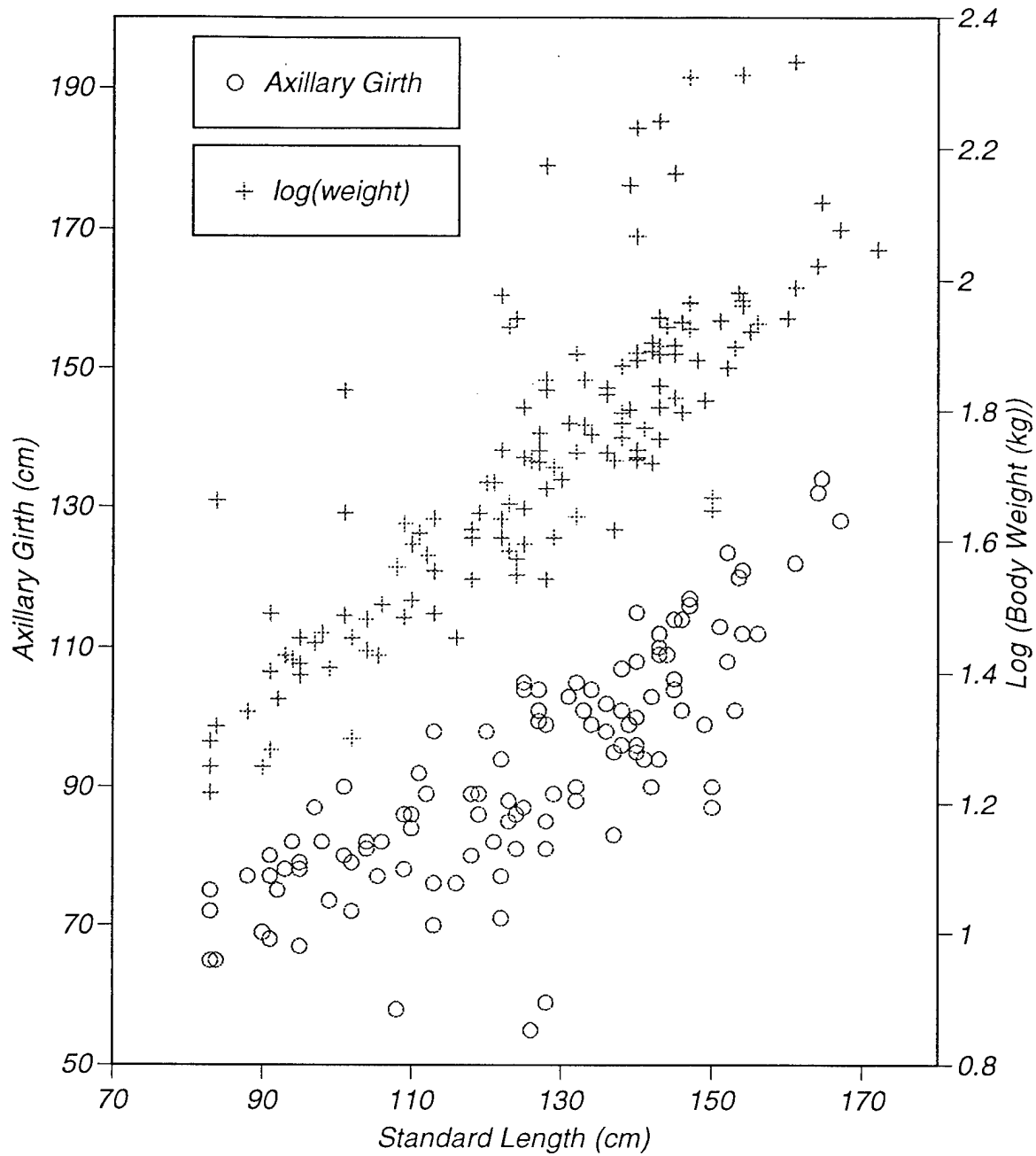

Figure 3. The proportion of male and female harbor seals captured per month between June 1994 and November 1996 in Elkhorn Slough, CA. Multiple captures within a month were pooled. The number of seals captured during each month was in parentheses along the x-axis.



**Figure 4.** The relationship between length and girth, and length and base-10 log of weight (kg). Data were obtained from 141 harbor seals captured and measured in Elkhorn Slough, CA between July 1994 and November 1996.

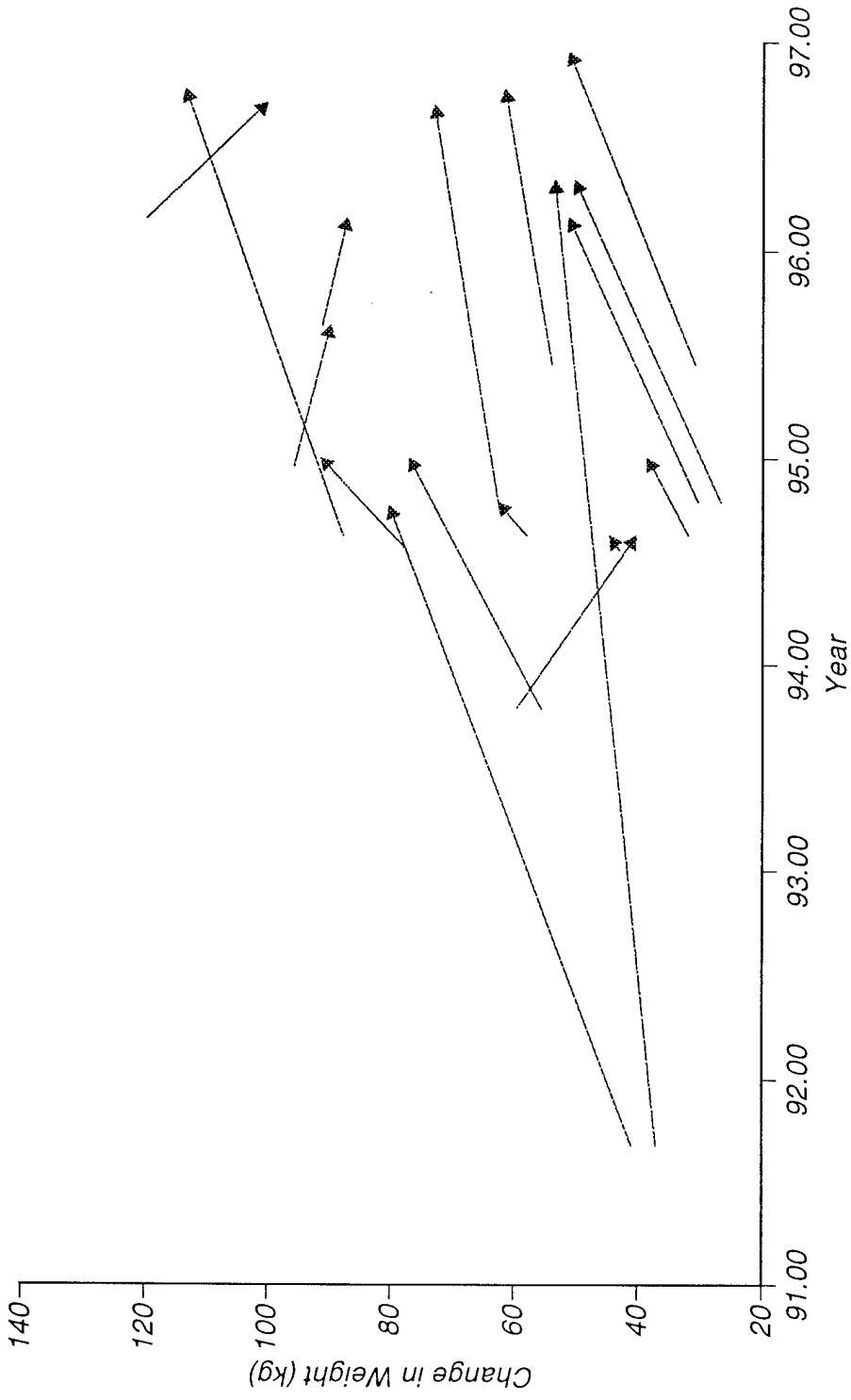

Figure 5. Change in the weight (kg) of 16 harbor seals captured and recaptured in Elkhorn Slough between September 1991 and November 1996.

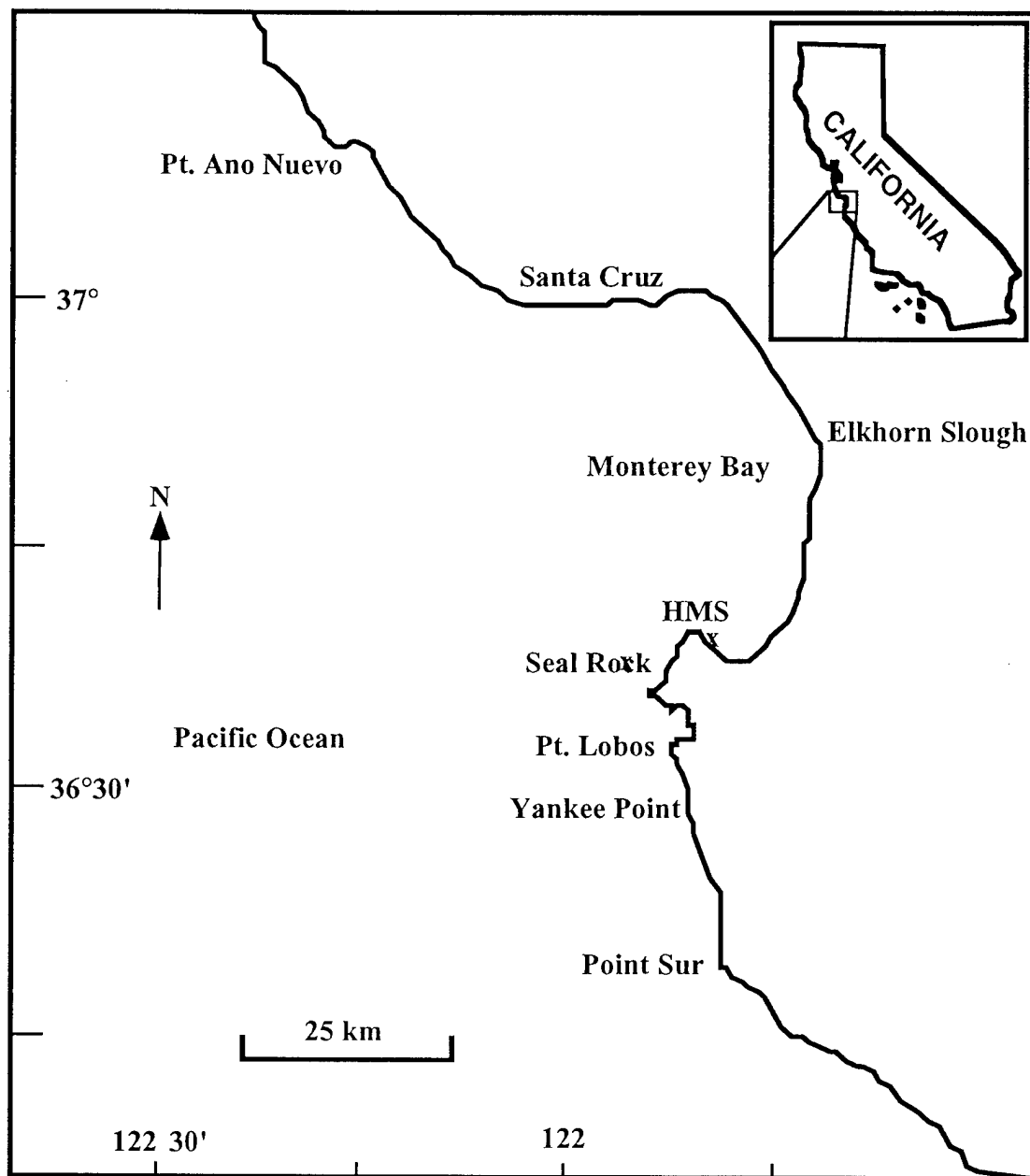

Figure 6. Destinations (haul-out sites) of long distance movements observed in five harbor seals tagged in Elkhorn Slough, California, between July 1994 and November 1996. HMS: Hopkins Marine Station

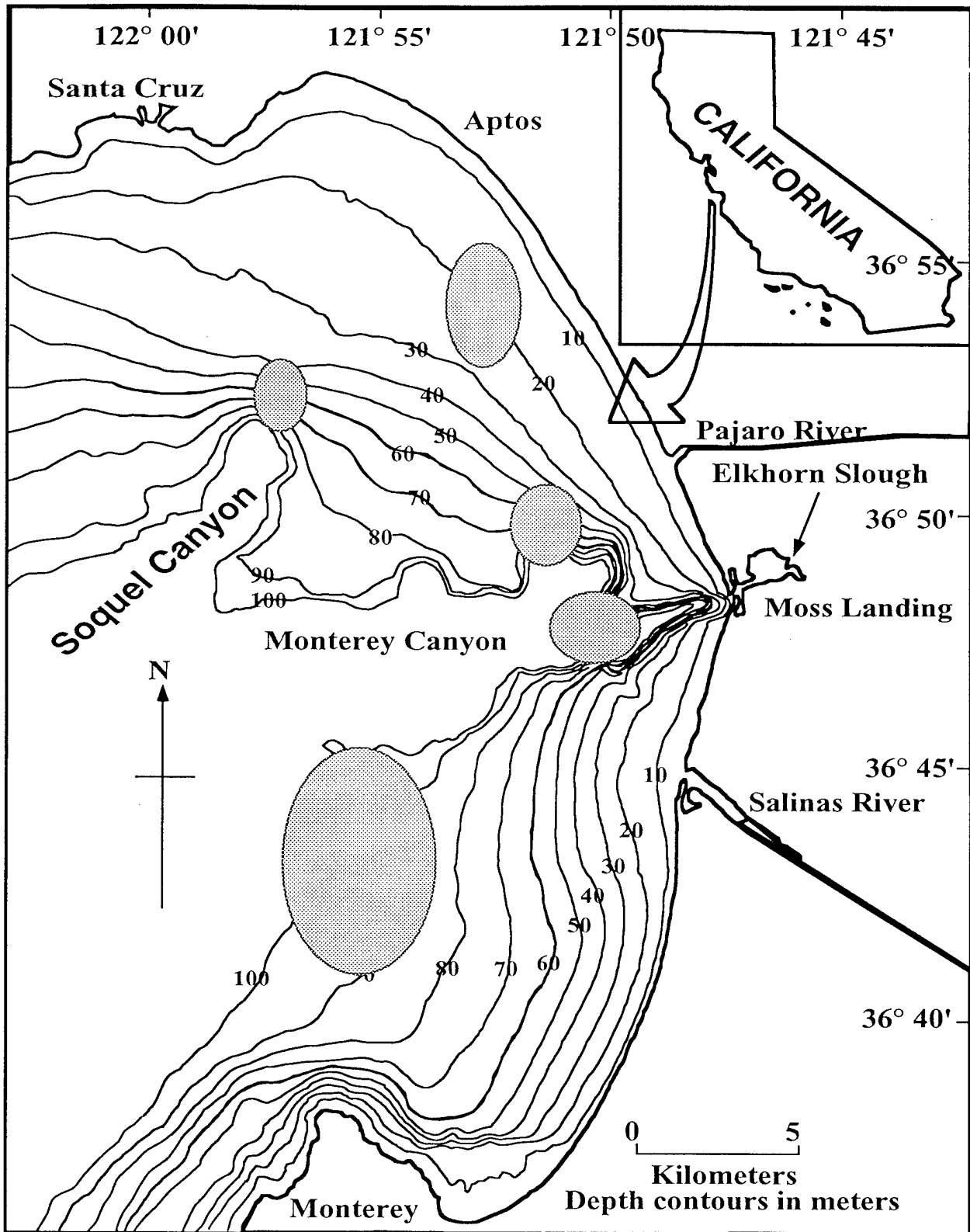
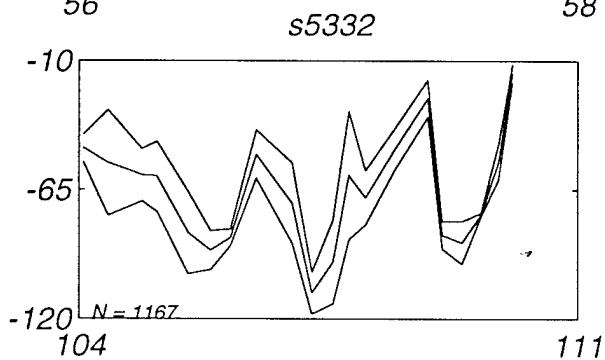
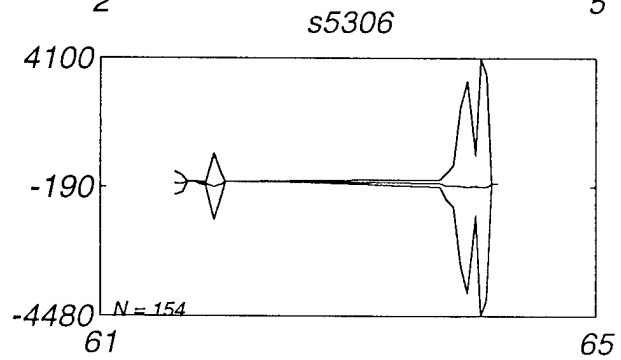
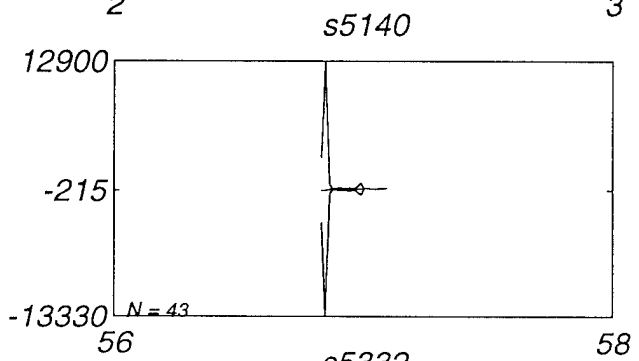
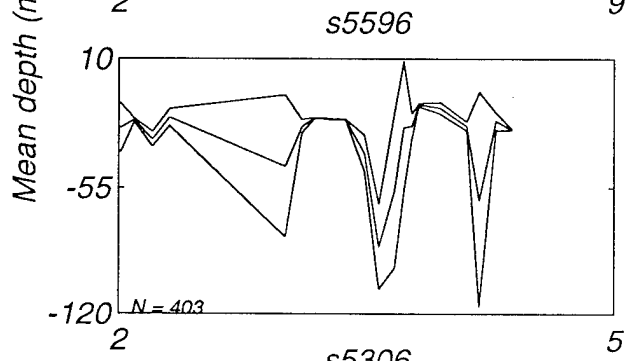
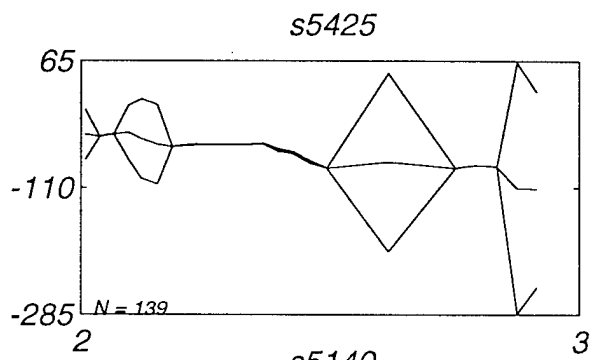
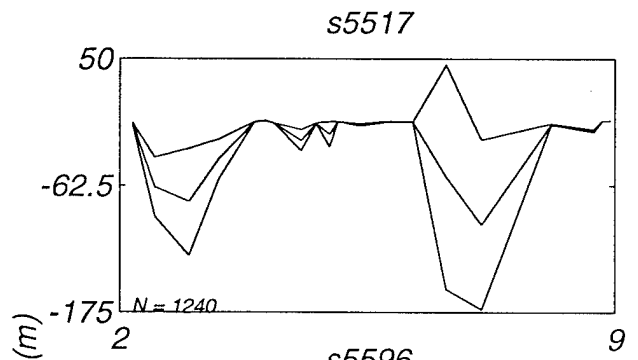

Figure 7. Foraging areas (stippled) of radio-tagged harbor seals tagged in Elkhorn Slough, CA between July 1994 and November 1996.

**Figure 8.** Changes in mean depths of dives ( $\pm$  SE) of 18 harbor seals tagged with TDRs between August 1994 and October 1996. Dives in Elkhorn Slough were excluded from the analysis. Mean depths and standard errors of dives were calculated for every 5% of total dives (N).



Julian Days

Julian Days

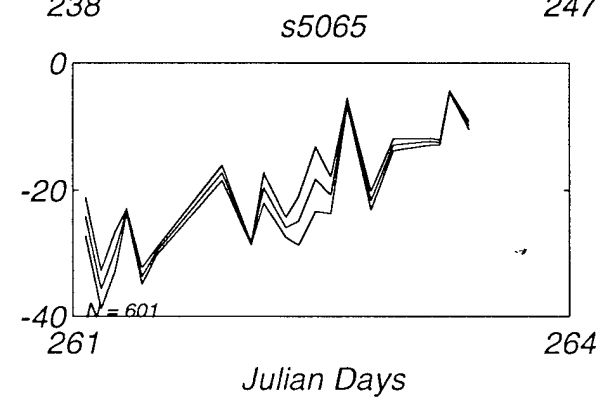
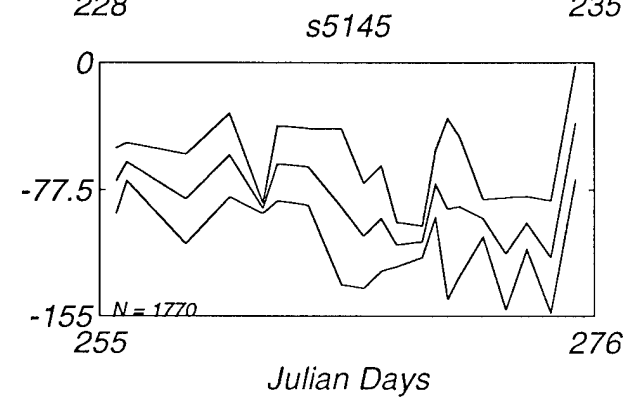
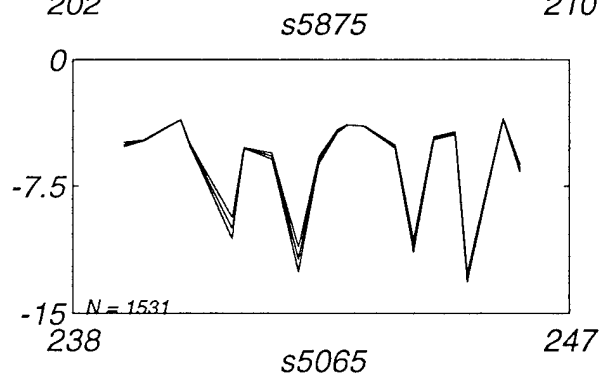
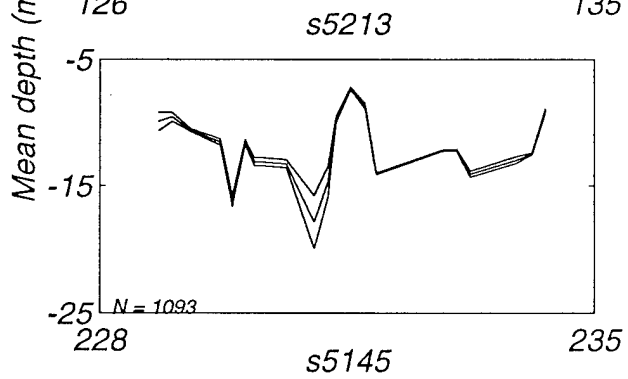
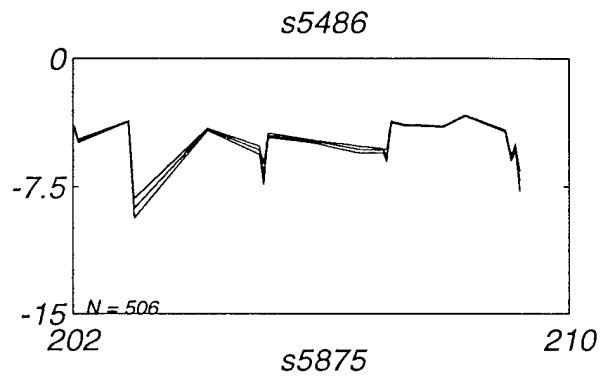
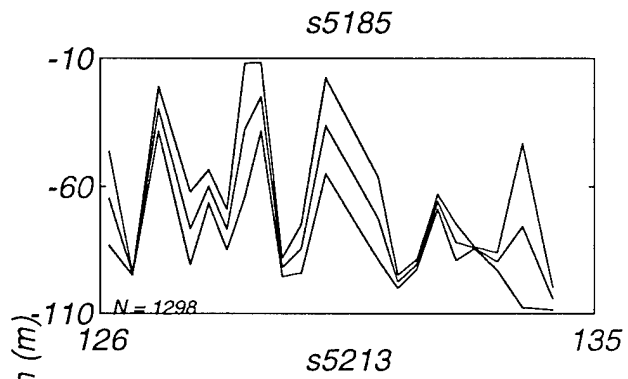

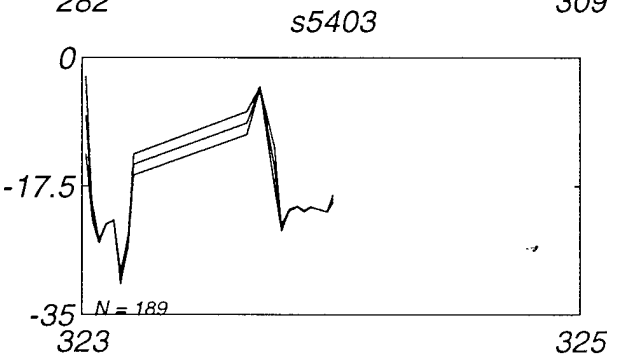
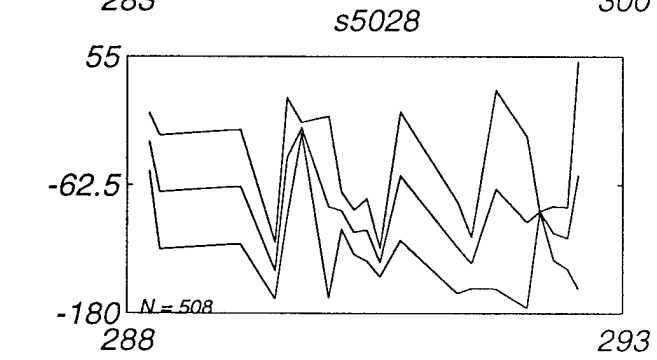
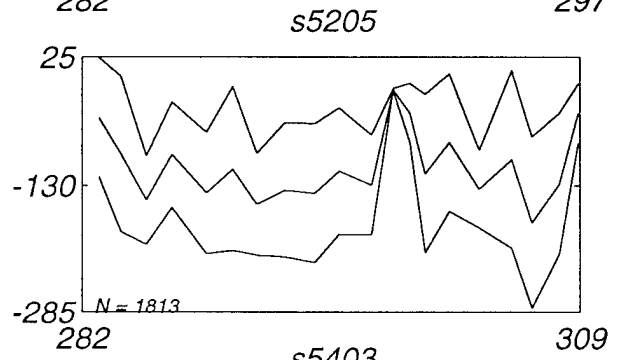
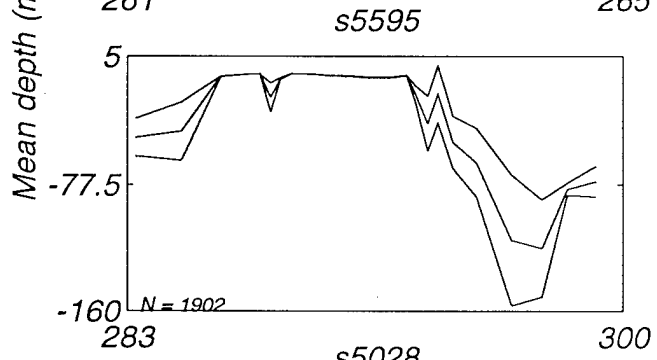
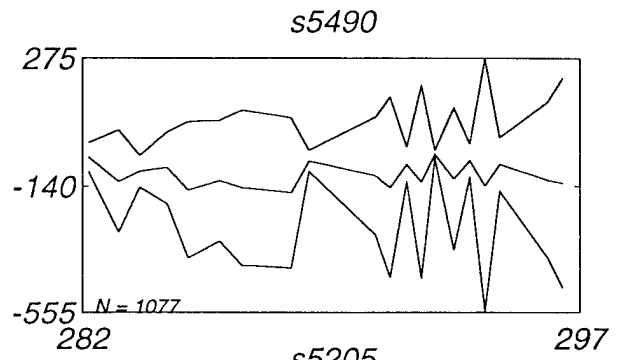
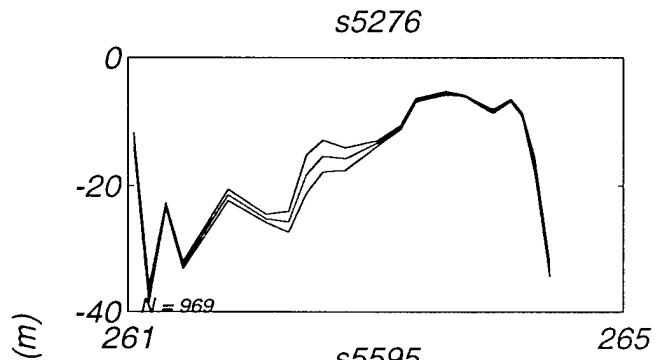

Julian Days

Julian Days

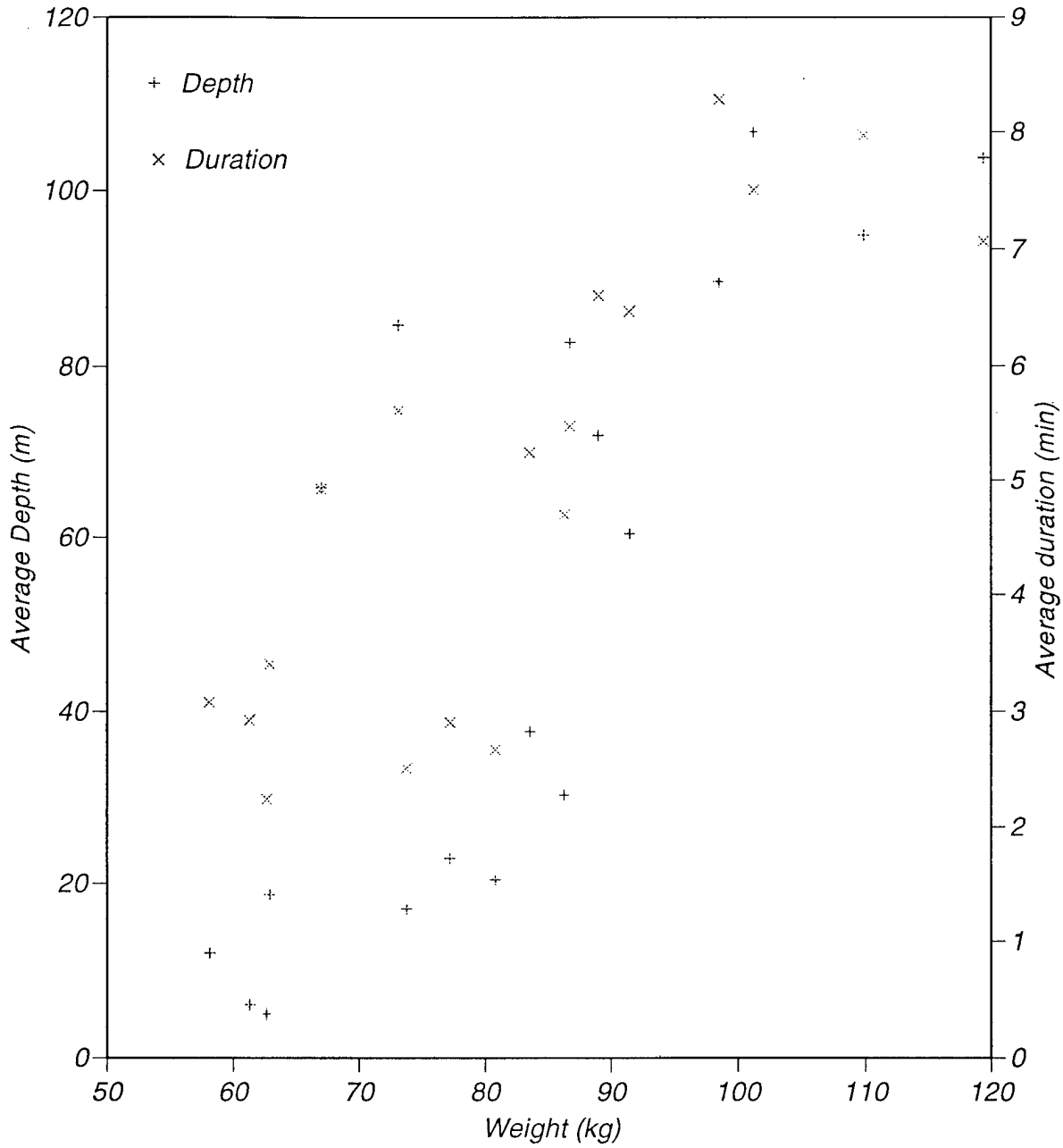

**Figure 9. Relationship between body weight (kg) and the average depth and duration of dives of 18 harbor seals tagged in Elkhorn Slough between June 1994 and November 1996. Dives within Elkhorn Slough were excluded from the analysis.**

**Figure 10.** Change in the maximum depth of dives of 18 harbor seals tagged between August 1994 and October 1996 as a function of time of the day and day of the year. Dives in Elkhorn Slough were excluded.

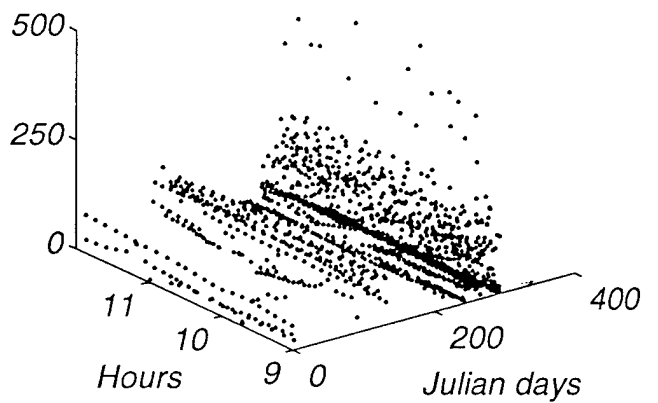
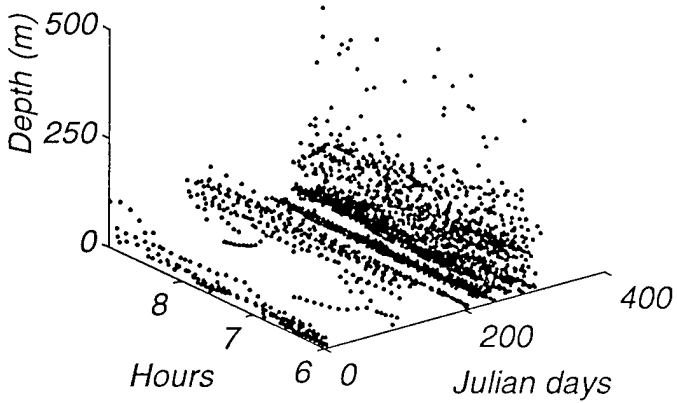
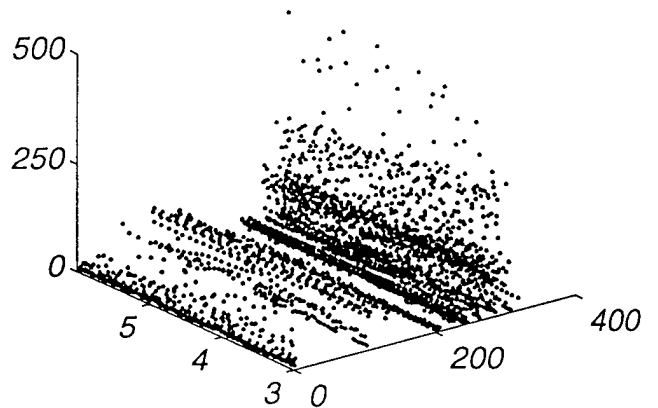
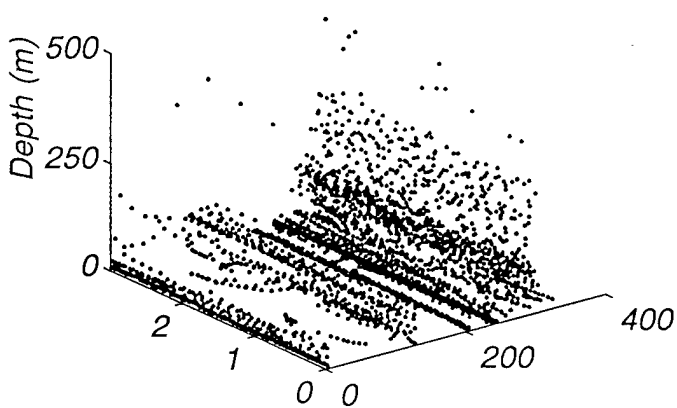

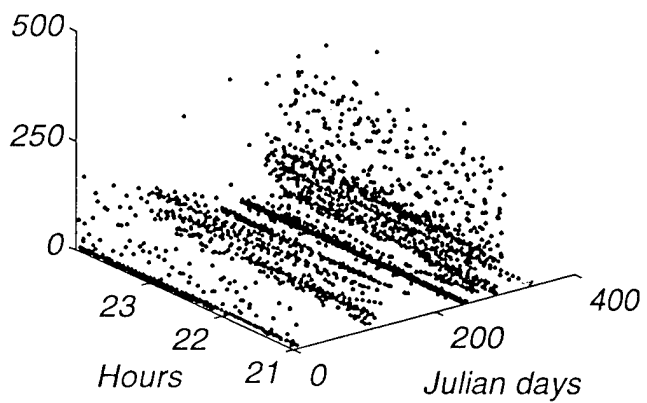
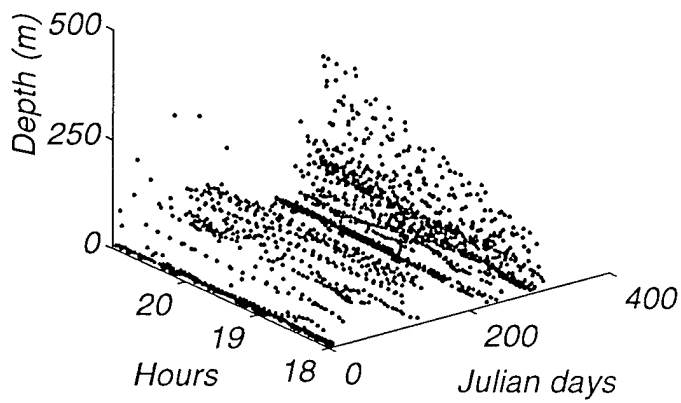
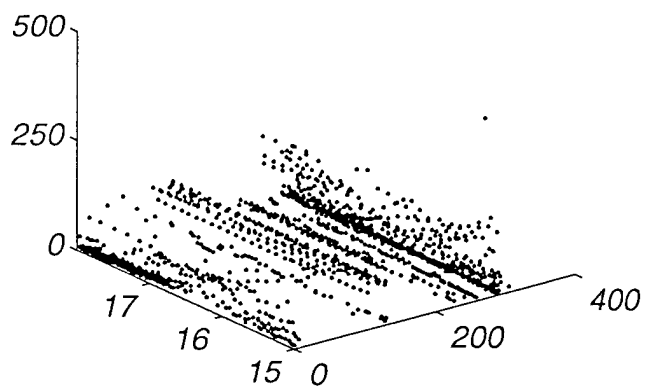
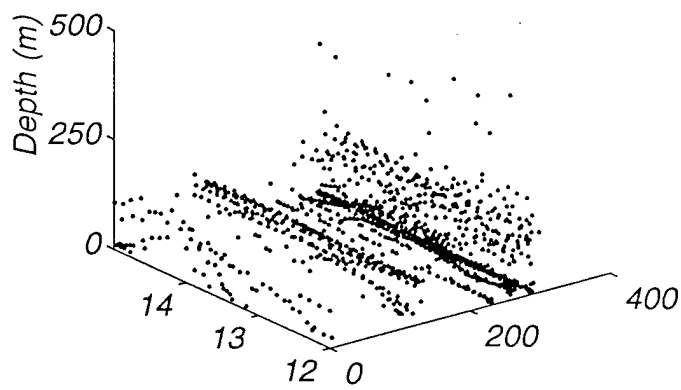

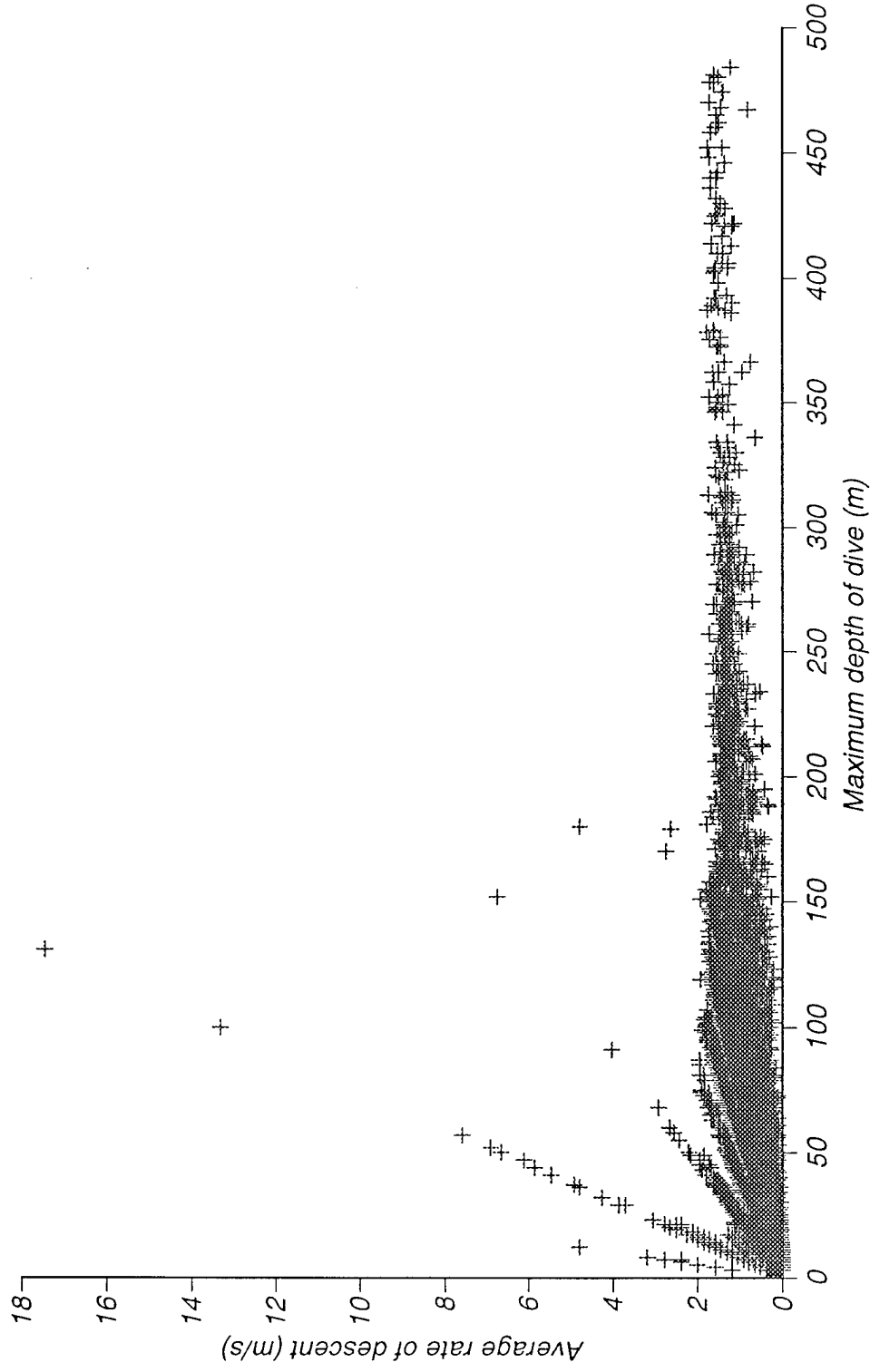

Figure 11. Relationships between the maximum depth of dives (m) and the average rates of descent (m/s). The end of descent was defined as the time when the 85% of the maximum depth was reached.

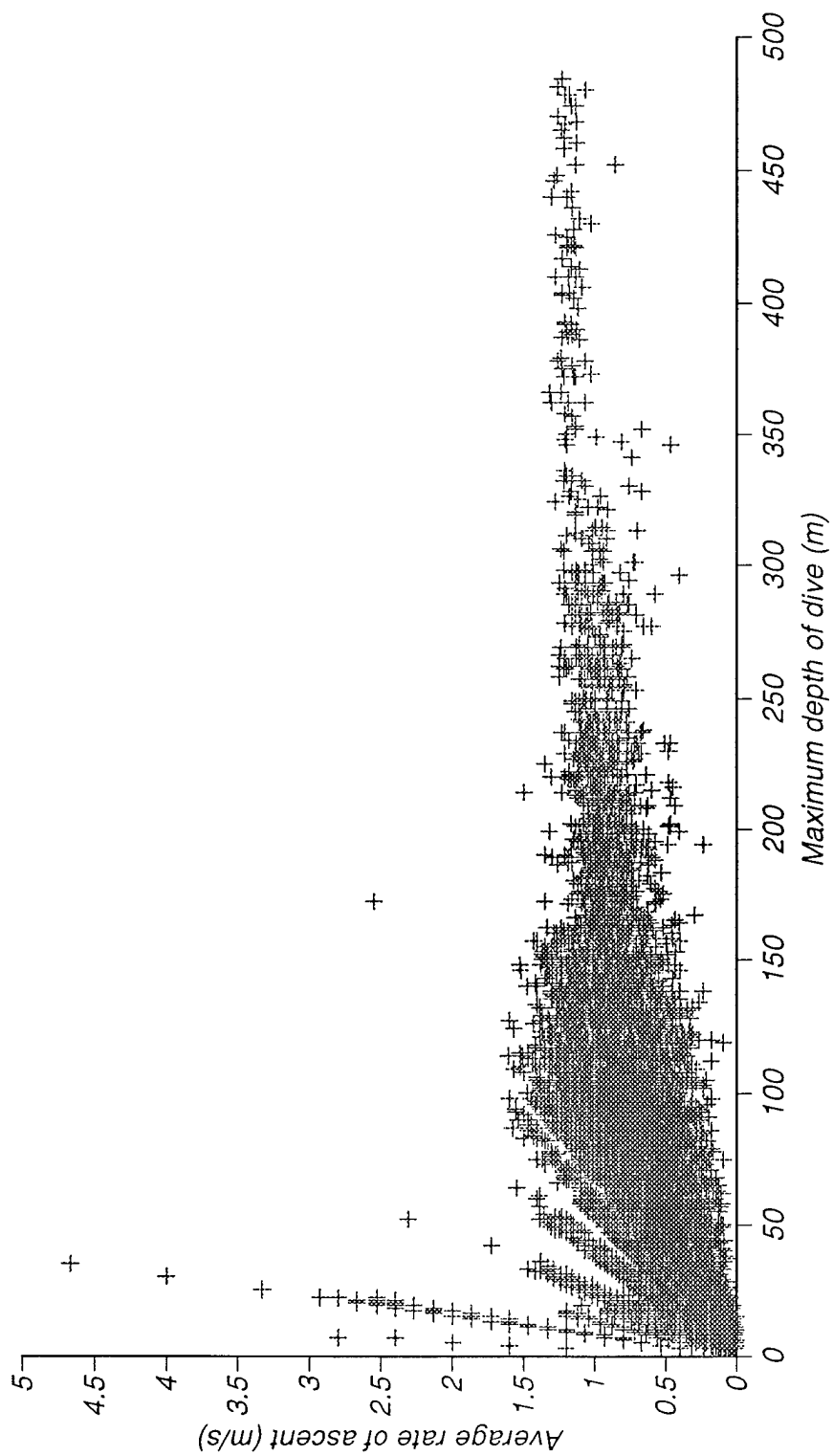

Figure 12. Relationship between the maximum depth of dive (m) and the average rate of ascent (m/s). The beginning of ascent was defined as the time when the depth reading became less than the 85% of the maximum depth.

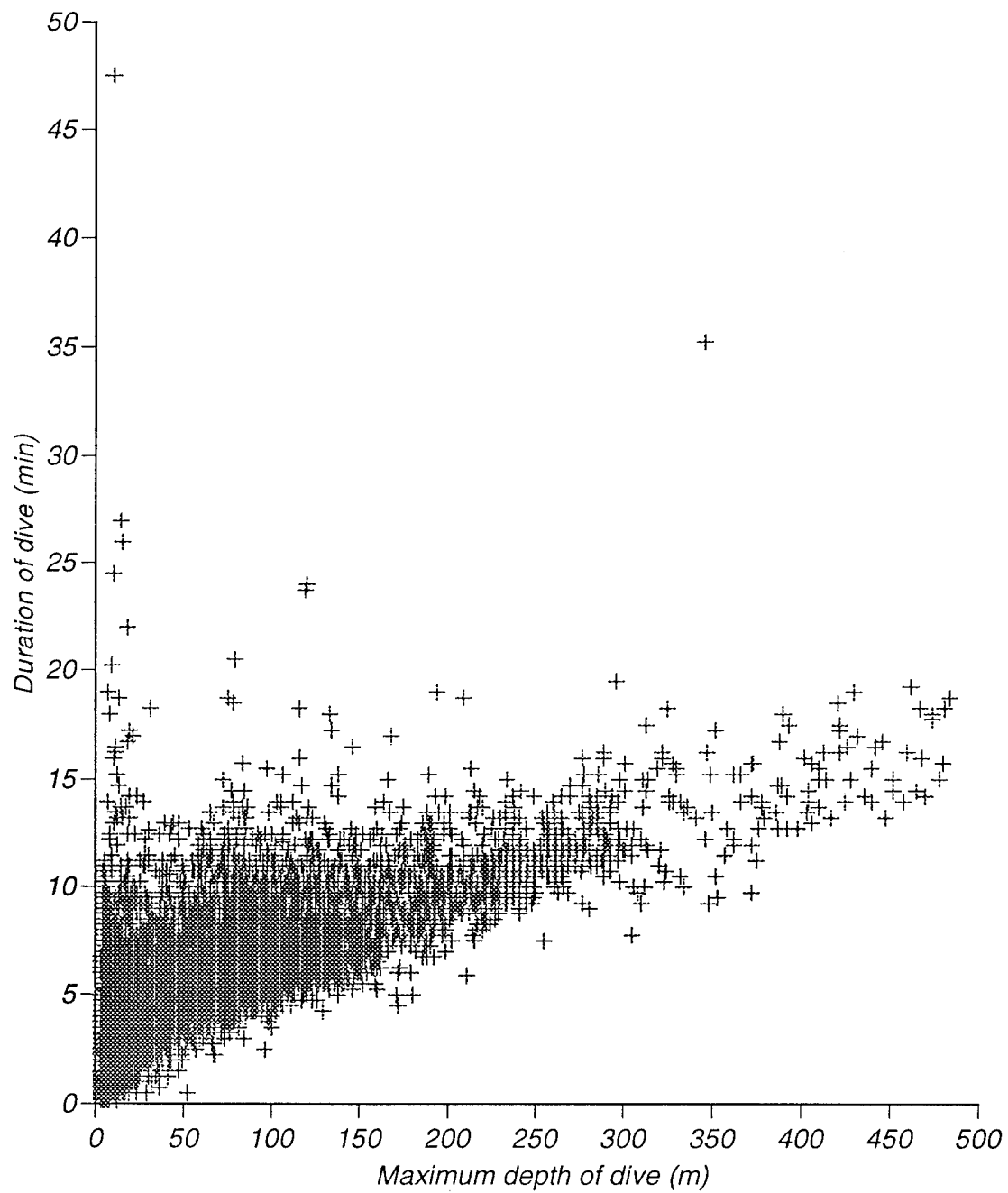

Figure 13. The relationship between maximum depth and duration of dives of 18 harbor seals tagged with TDRs in Elkhorn Slough, CA, between July 1994 and November 1996.

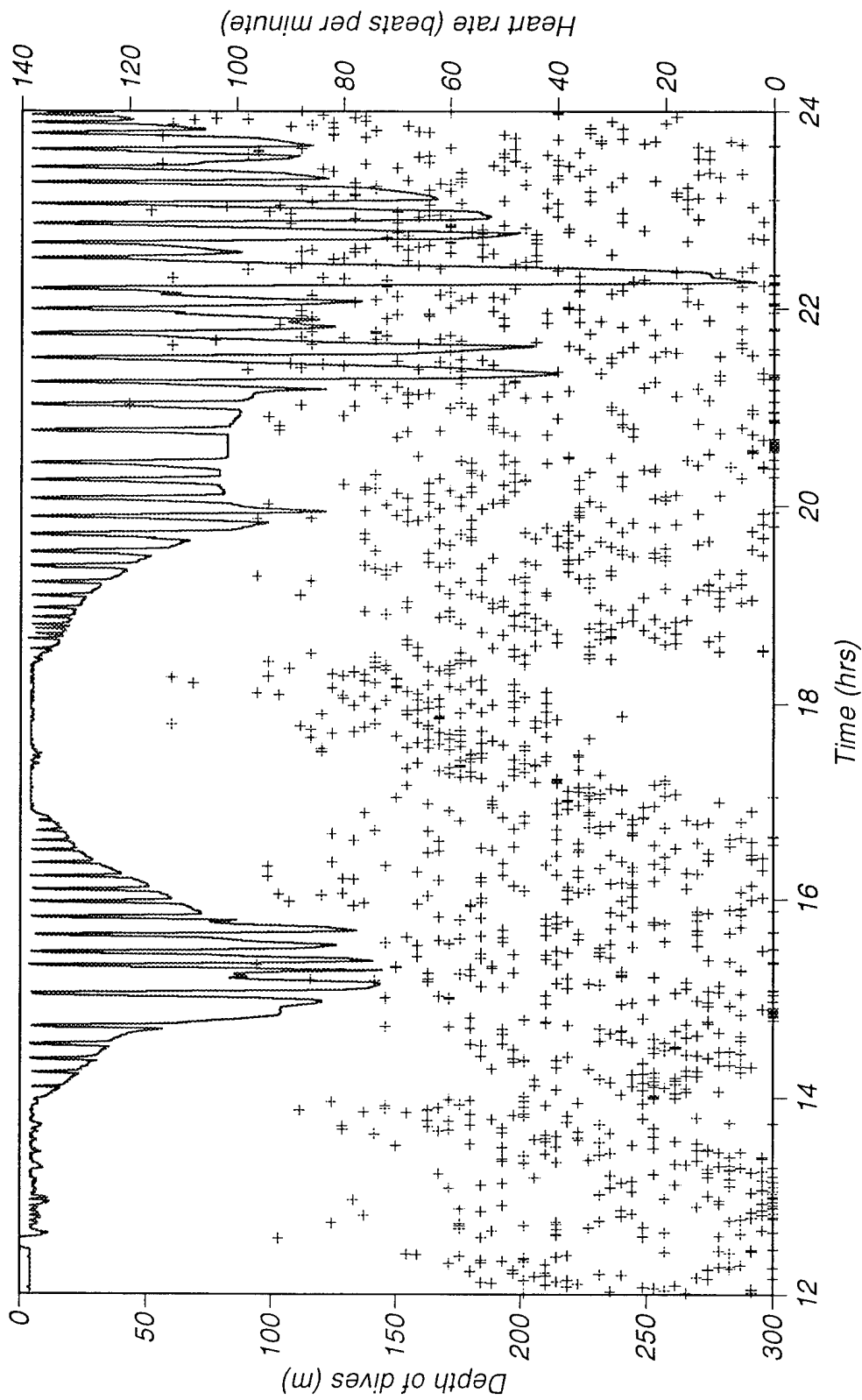

Figure 14a. Heart rates (+) and depth of dives (solid line) from a harbor seal (5306) swimming and diving in Monterey Bay. Consecutive dives appeared to follow the bottom contour.

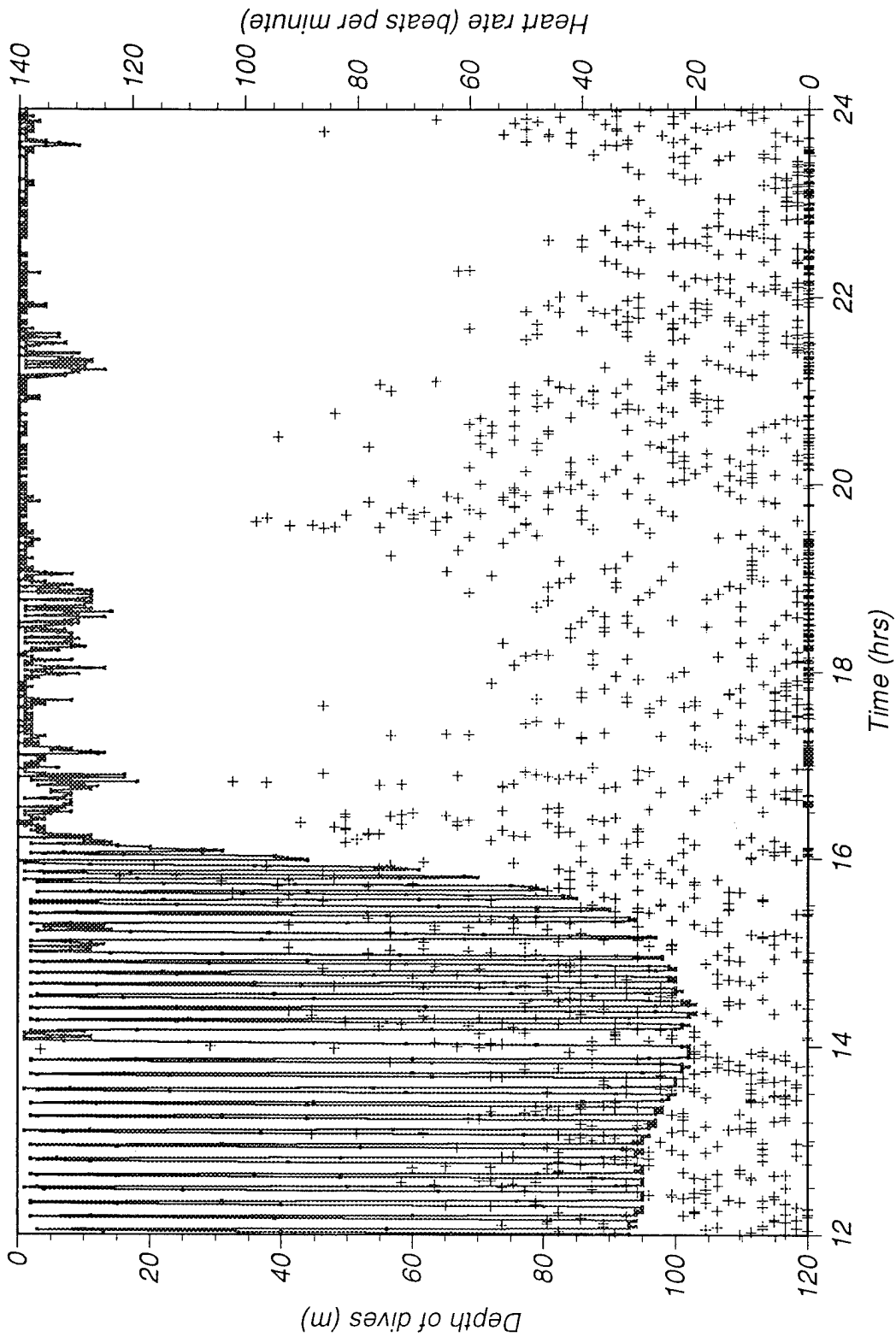

Figure 14b. Heart rates (+) and depth of dives (solid line) from a harbor seal (5185) swimming and diving in Monterey Bay. Consecutive dives appeared to follow the bottom contour.

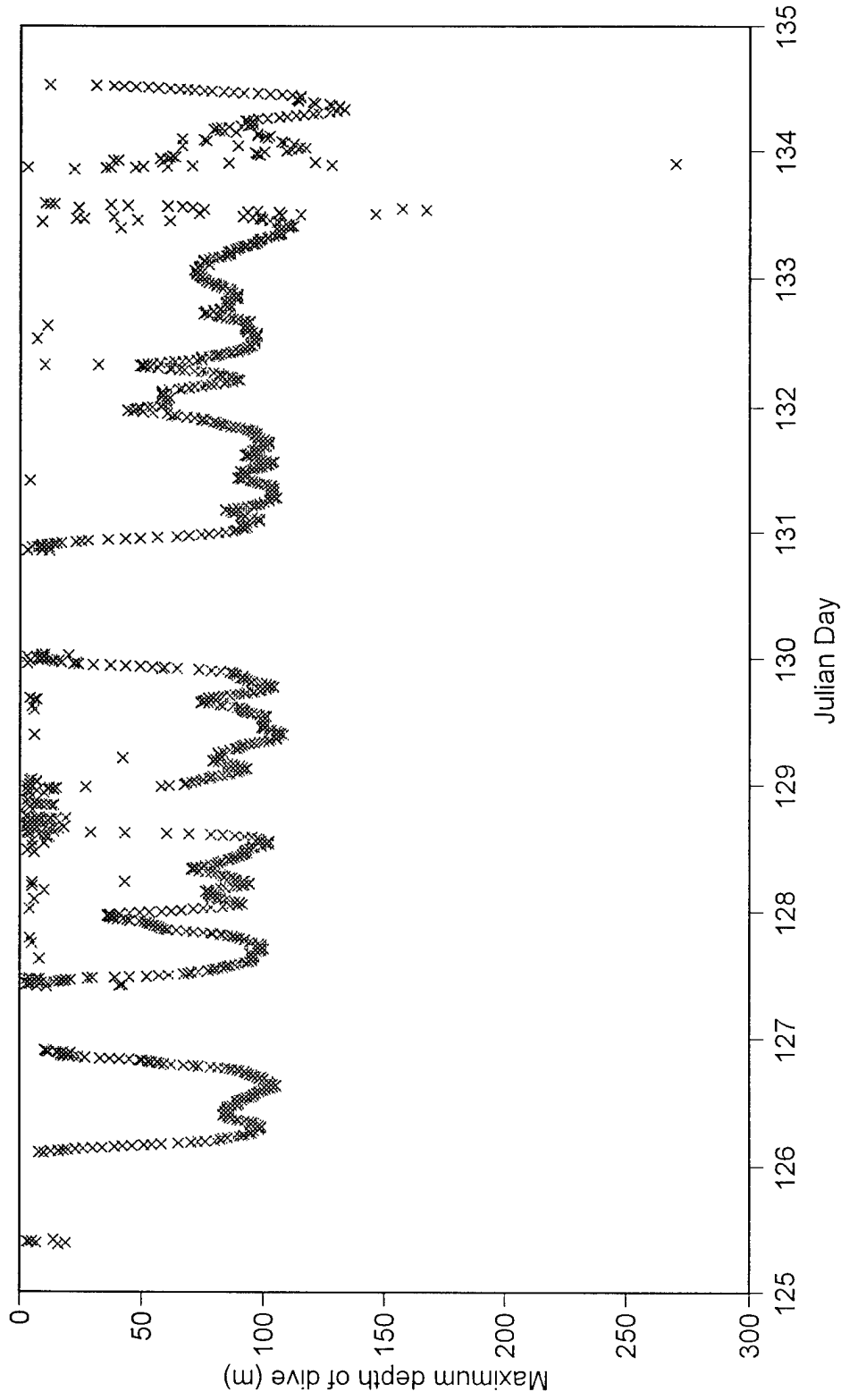

Figure 15. An example of consecutive foraging dives of a harbor seal (s5185) in Monterey Bay. Each x indicates the maximum depth of a dive. The seal returned to the same depth in consecutive foraging trips.