

# MC ALESTER ARMY AMMUNITION PLANT ENERGY ENGINEERING ANALYSIS PROGRAM

CONTRACT NUMBER DACA63-82-C-0191

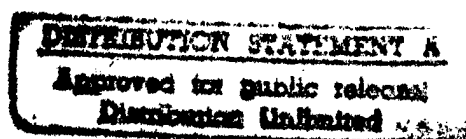

## EXECUTIVE SUMMARY FINAL SUBMITTAL VOLUME I

DTIC QUALITY INSPECTED 2

JULY 24, 1984

19971021 315

**Norman D. Kurtz Consulting Engineers**  
member of The F + K Group





DEPARTMENT OF THE ARMY  
CONSTRUCTION ENGINEERING RESEARCH LABORATORIES, CORPS OF ENGINEERS  
P.O. BOX 9005  
CHAMPAIGN, ILLINOIS 61826-9005

REPLY TO  
ATTENTION OF: TR-I Library

17 Sep 1997

Based on SOW, these Energy Studies are unclassified/unlimited.  
Distribution A. Approved for public release.

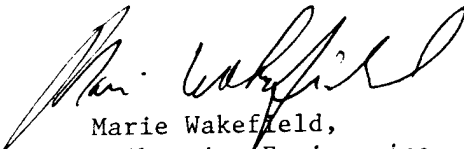
  
Marie Wakefield,  
Librarian Engineering

ENERGY ENGINEERING ANALYSIS PROGRAM  
McALESTER ARMY AMMUNITION PLANT  
McALESTER, OKLAHOMA

EXECUTIVE SUMMARY  
FINAL SUBMITTAL  
CONTRACT NUMBER DACA63-82-C-0191

July 24, 1984

Prepared for  
U.S. ARMY CORPS OF ENGINEERS  
Tulsa District  
P.O. Box 61  
Tulsa, Oklahoma 74121

Prepared by  
NORMAN D. KURTZ, CONSULTING ENGINEERS/  
MEMBER OF THE F+K GROUP  
1425 Market Street  
Denver, Colorado 80202

## TABLE OF CONTENTS

	PAGE
I. EXECUTIVE SUMMARY	I-1
1. Purpose and Scope	I-1
1.1 Introduction	I-1
1.2 Report Organization	I-1
1.3 EEAP Objectives	I-2
2. McAlester Army Ammunition Plant Statistics	I-6
2.1 General Data	I-6
2.2 Production Capabilities	I-6
2.3 Other Activities and Facilities	I-6
3. Energy Use and Cost History	I-7
3.1 Overview	I-7
3.2 Energy Sources	I-7
3.3 Energy Costs	I-8
4. FY 82 Energy Analysis	I-16
4.1 Overview	I-16
4.2 Summary of Source Energy Consumption and Costs	I-16
4.3 Installation Energy Consumption	I-20
5. FY 82 Utility Analysis	I-34
5.1 Overview	I-34
5.2 Electricity	I-34
5.3 Natural Gas and Supplemental Boiler Fuel	I-46

6.	Energy Conservation at McAAP	I-49
6.1	Energy Reduction Goals	I-49
6.2	Energy Related Issues - Summary	I-49
6.3	Energy Conservation Investment Program	I-51
6.4	Summary of Energy Costs on Date of Analysis	I-54
7.	Energy Conservation Measures Developed - Increments A, B & G	I-55
7.1	Summary of Energy and Cost Savings	I-55
7.2	Theoretical Energy and Cost Savings	I-55
7.3	ECM's Investigated	I-55
7.4	Analysis Methods	I-56
7.5	List of Buildings Studied for ECO's	I-56
8.	Other Energy Conservation Items	I-61
8.1	Increment 'C'	I-61
8.2	Increment 'D'	I-61
8.3	Increment 'F'	I-62
8.4	Master Plan	I-63
9.	Energy Plan	I-63
9.1	Near-Term Actions	I-63
9.2	On-Site Gas Supply	I-64
9.3	Long-Term Programs	I-64
9.4	Policy Issues	I-64

Index to Charts and Graphs

<u>Figure</u>	<u>Description</u>	<u>Page</u>
---	Installation Site Map	I-3
I-1	Annual Source Energy, FY 75 to FY 82	I-9
I-2	Annual Energy Costs, FY 75 to FY 82	I-9
I-3	Source Energy Breakdown, FY 75 to FY 82	I-10
I-4	Energy Cost Breakdown, FY 75 to FY 82	I-10
I-5	Historical Electrical Consumption	I-11
I-6	Historical Electrical Costs	I-11
I-7	Historical Natural Gas Consumption	I-12
I-8	Historical Natural Gas Costs	I-12
I-9	Historical Petroleum Fuel Consumption	I-13
I-10	Historical Petroleum Fuel Costs	I-14
I-11	Historical Total Petro-Fuel Costs	I-15
I-12	FY 82 Source Energy Breakdown	I-18
I-13	FY 82 Energy Cost Breakdown	I-18
I-14	FY 82 Monthly Source Energy Use	I-19
I-15	FY 82 Monthly Energy Cost	I-19
I-16	Installation Energy Use	I-22
I-17	Typical Production Boiler Plant	I-26
I-18	Production Boiler Plants Natural Gas Use	I-27
I-19	Typical Boiler Plant Energy Requirements	I-27
I-20	Boiler Plant 185-B Energy Requirements	I-27
I-21	Typical Production Building Annual Energy Requirements	I-28

<u>Figure</u>	<u>Description</u>	<u>Page</u>
I-22	Production Building with Electrical Motors	I-28
I-23	Typical Production Building on Stand-by Status	I-28
I-24	Typical Administration Building	I-31
I-25	Typical Industrial Shop	I-31
I-26	Typical Residence	I-31
I-27	Agency Report of Motor Vehicle Data	I-33
I-28	FY 82 Electric Energy Breakdown	I-36
I-29	FY 82 Electric Cost Breakdown	I-36
I-30	FY 82 Monthly Electric Energy Use	I-37
I-31	FY 82 Monthly Electric Utility Costs	I-37
I-32	Electric Demand Profile for January	I-38
I-33	Electric Demand Profile for August	I-38
I-34	Typical Week Demand Profile - January	I-39
I-35	Typical Week Demand Profile - January	I-40
I-36	Typical Week Demand Profile - August	I-41
I-37	Typical Week Damand Profile - August	I-42
I-38	Typical Daily Power Factor Profile	I-43
I-39	Typical Daily Power Factor Profile	I-43
I-40	Monthly Load Factors	I-44
I-41	Monthly Power Factor Profiles	I-45
I-42	Monthly Gas Consumption	I-48
I-43	Monthly Gas Costs	I-48
I-44	Monthly Gas Cost Adjustment	I-48

<u>Figure</u>	<u>Description</u>	<u>Page</u>
I-45	Summary Chart of Energy Projects and Savings	I-57
I-46	Summary Chart of Theoretical Savings	I-58
I-47	Summary Chart of FE Measures	I-59
I-48	Summary Chart of Non-Feasible ECM's	I-60

## I. EXECUTIVE SUMMARY

### 1. PURPOSE AND SCOPE

#### 1.1 Introduction

1.1.1 This document is presented as the Final Submittal for the Energy Engineering Analysis Program (EEAP) conducted at McAlester Army Ammunition Plant (McAlester or McAAP) for work under Contract Number DACA63-82-C-0191.

1.1.2 This report summarizes the EEAP through the completion of Phase III. This phase includes the evaluation of energy programs, resulting in a series of conclusions and recommendations. Programming documents were also developed and are provided in a separately bound volume.

#### 1.2 Report Organization

1.2.1 The report is divided into seven sections, with a separate appendix volume to parallel and support the narrative discussions in these sections.

##### 1.2.2 Section I - Executive Summary

Provides an overview of basewide energy consumption, utility cost analysis, energy conservation measures and ECIP projects developed, projected energy requirements after ECM's are implemented, and policy changes.

##### 1.2.3 Section II - Increment 'A'

Projects involving modifying, improving or retrofitting existing buildings.

##### 1.2.4 Section III - Increment 'B'

Projects involving utilities and energy distribution systems. The analyses of an EMCS and the re-insulation of steam supply lines are presented.

##### 1.2.5 Section IV - Increment 'C'

Renewable energy projects. Although this increment is not part of the contract, a discussion of solar systems is provided.

1.2.6 Section V - Increment 'D'

Cogeneration systems. This increment was added to the contract at a later date. An analysis, meeting the requirements for an pre-final submittal, is presented.

1.2.7 Section VI - Increment 'F'

Facilities Engineer Energy Master Plan. In-depth review of previous energy conservation programs, all ECO's considered for this installation, and an Energy Master Plan.

1.2.8 Section VII - Increment 'G'

Projects that are economically feasible but do not meet the requirements of the ECIP program.

1.3 EEAP Objectives

The EEAP study at McAlester will result in a comprehensive base-wide energy plan. The plan will describe modifications to maximize efficiency of the existing installation and recommend investment opportunities to further reduce energy use. The plan will be developed to reduce energy consumption in compliance with the objective set forth in the Army Facilities Energy Plan. All practical methods of energy conservation will be evaluated for economic feasibility.

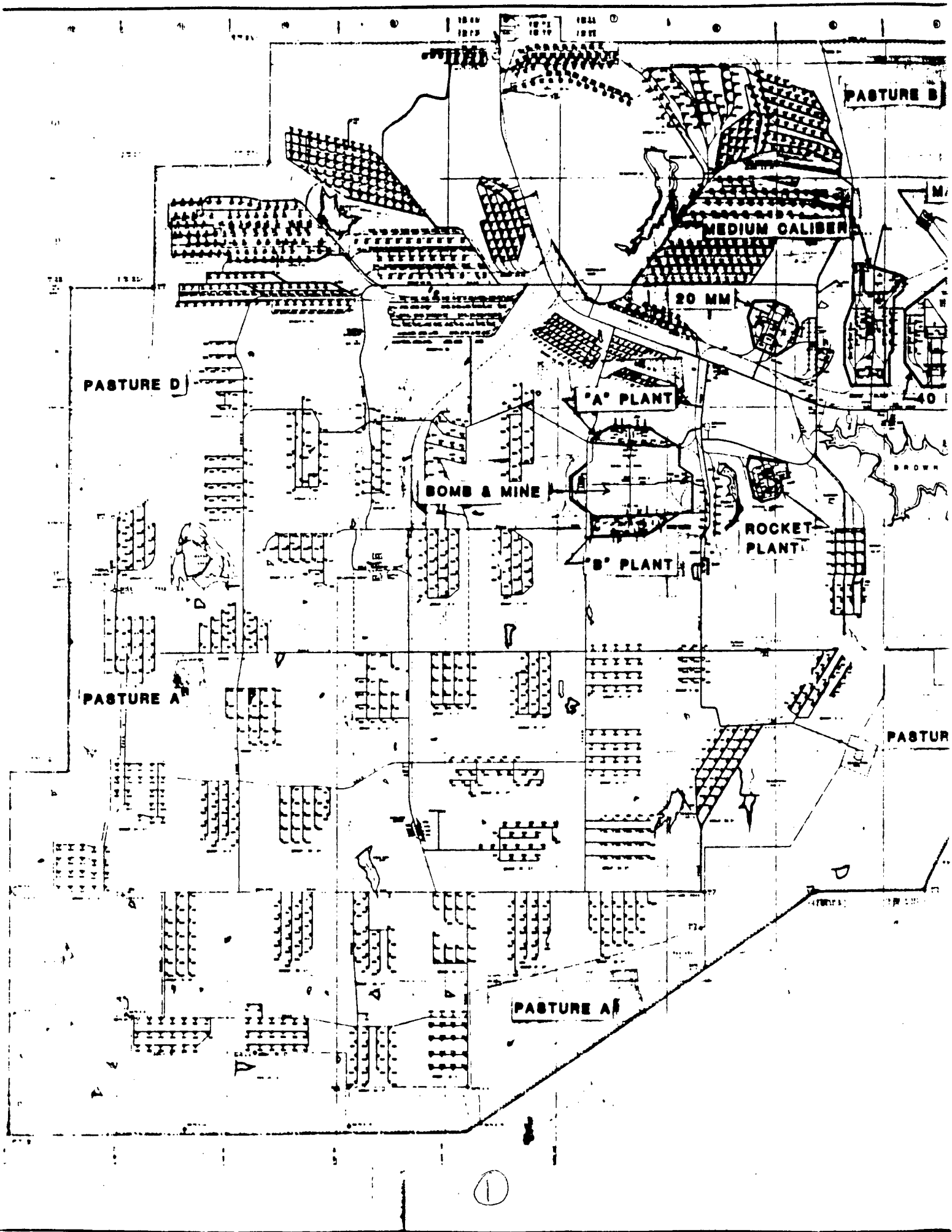

PASTURE B

MEDIUM CALIBER

20 MM

PASTURE D

'A' PLANT

BOMB & MINE

ROCKET PLANT

'B' PLANT

PASTURE A

PASTUR

PASTURE A

1

PASTURE B

MAJOR CALIBER

ADMIN. & SUPPORT

40 MM

BROWN LAKE

WATER/SEWAGE TREATMENT

PASTURE A

MCALESTER AMMUNITION PLANT  
MCALESTER, OKLAHOMA

SCALE:

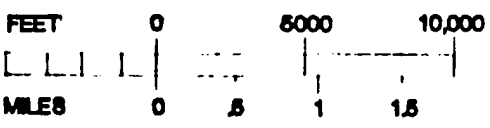

2

LIST OF BUILDINGS SURVEYED  
Ammunition Plant

McAlester Army

<u>NUMBER</u>	<u>DESCRIPTION</u>	<u>AREA</u>
1	Headquarters Building	39,567
2	EM Barracks w/mess	40,614
3	Rec./Exchange Building	16,832
4	Cafeteria	15,493
5	Dispensary	8,185
6	Fire House	5,815
7	Lab/Test Building	8,689
8	Gen. Purp. Admin/Warehouse	20,440
9	Maintenance Shop	24,410
10	Loco/Crane Shop	4,153
11	Pain Shop	2,751
14	Auto Repair Shop	34,094
14-n	Maint. Shop Elec. & Pipe	22,787
15	Chemistry Lab	1,558
26	Bath House	800
29	Resident	3,276
30	--	5,249
31	Provost Marshall	10,674
40	Water Filter Pump Building	2,197
41	Chem. Feed Water Plant	1,318
45/46	Celestine Transfer Depot	12,000
83	BOQ - Quarters F	5,527
90	Admin. Gen. Purp.	2,232
92	Field Engineer	1,000
100	Cartridge Case Fill	23,363
103	Cartridge Case Fill	21,438
105	Lunch/Locker Building	37,923
105-B	Boiler House	1,658
106	Ammo Renovation Shop	33,376
108-B	Boiler House	1,197
109	Explosive "D" Load Building	15,972
110-B	Boiler House	2,011
111	Explosive "D" Load Building	15,972
126	Mel. Cal Log Building	24,872
128	Comp. Air Plt.	1,110
129	Lunch & Locker Building	25,715
129-B	Boiler House	2,050
130	APAM Log Building	28,863
133	Explo. "D" Sifting Building	2,009
134	Tank Repair Building	14,305
135	Case Overhaul Building	14,285
136-B	Boiler House	2,054
141-B	Boiler House	1,196

142	Case Fill Building	13,947
161	Tetryl/Tracer Load Building	15,826
162	Cartridge Assembly Building	16,450
163	Tetryl/Tracer Load Building	16,826
164	Cartridge Assembly Building	16,450
165-B	Boiler House	1,634
172	Bomb & Mine Fill Building	5,535
175	Bomb & Preparation Building	25,894
178	TNT Stge.	1,136
179	Box Emptying Building	648
182	Powdered Metal Stge.	1,364
185-B	Boiler House	4,530
186	Finishing Building	8,364
196	Nitrate Prep Building	2,808
198	Fising and Drilling Building	13,000
201	Fising and Drilling Building	13,000
220	Propellant Plant	29,462
224	Propellant Plant	3,254
228	Lunch and Locker	12,918
229	Boiler House	2,346
343	Inspecting	5,202
344	Surveillance	12,393
345	Surveillance	4,182
346	A/C Plt.	3,162
430	Dunnage Mill Shop	8,200
431	Dunnage Mill Office/Shop	4,100
452	Demil Building	3,000
464	Sewage	81
476	Office Building	1,632
606	Family Housing (officers)	1,624
666	Facilities Eng. Office	2,400

## 2. MCALESTER ARMY AMMUNITION PLANT STATISTICS

### 2.1 General Data

2.1.1 Land Area (Reference the enclosed installation site map)  
44,961.64 acra (70.25 sq. mi.) of government owned property; 2.39 acres under permanent lease

2.1.2 Buildings, Structures and Grounds  
1,651,888 sq. ft. of building floor area; 2023 ammunition magazines; 397 mi. of surfaced and paved roads; 194 mi. of railroad tracks.

2.1.3 FY 1982 Workforce  
Annual average of 950 military and civilian personnel.

2.1.4 FY 1982 Residents  
Annual average of 120 people residing on base

### 2.2 Production Capabilities

2.2.1 Gun Ammunition  
20 MM - all types; 40MM - all types; 3 inch - all types; 5 inch and 6 inch - projectiles and cartridge cases

2.2.2 Rockets - Warheads and Motor Assembly  
2.75; 5 inch spin stabilized; 5 inch Zuni rockets

2.2.3 Bomb Assembly and Loading  
250 lb. MARK 81; 500 lb. MARK 82; 1000 lb. MARK 83; 2000 lb. MARK 84; 750 lb. MARK 117; 3000 lb. MARK 118A; APAM bombs

2.2.4 Cast Loading  
Depth charges; bombs; mines; warheads

### 2.3 Other Activities and Facilities

Explosives overhaul; Explosives disposal; Naval special weapons; Bomb and Mine 'A' plant modernization (under construction); Marine barracks; on-station barracks and residences.

### 3. ENERGY USE AND COST HISTORY

#### 3.1 Overview

Energy cost and consumption data from Fiscal Year 1975 to Fiscal Year 1982 were assembled and reviewed to establish an historical basis for analysis. Annual energy usage has varied from one year to the next, primarily due to varying levels of ammunition production; other variables include varying types of production, weather patterns, and implemented energy conservation projects. A historical comparison of annual energy usage is therefore difficult to make. Historical data are graphically represented in Figures I-1 to I-4.

#### 3.2 Energy Sources

Since 1975, McAAP has utilized the following sources to meet energy requirements.

##### 3.2.1 Electricity

Electricity delivered to the base is a combination of hydro-electric and thermally-generated power. The availability of inexpensive hydro-electric energy varies annually and monthly, depending on rainfall patterns. The electrical needs that cannot be met with hydro-electric are satisfied with thermally-generated power, at a significantly higher cost. Historically, annual electrical energy use has been relatively constant. An increase of electrical energy in FY 82 was primarily due to increased production levels and the construction of the Navy's Bomb and Mine 'A' Plant. Annual electrical consumption and costs are shown in Figures I-5 and I-6.

##### 3.2.2 Natural Gas and Boiler Fuel

3.2.2.1 Natural gas has been McAAP's primary energy source, providing 53% of all source energy consumed (65% of net energy) for the past eight years. The major user of natural gas is the boiler plants, located in the production areas, which generate high pressure steam for steam process loads and building heating. Annual gas use and costs are shown in Figures I-7 and I-8.

3.2.2.2 On occasion, the natural gas supply is subject to curtailment. When curtailment occurs, boiler fuel, i.e., #2 fuel oil, is supplied to the production boiler plants until the curtail-

ment is lifted. Historically, from 1975 to 1982, this boiler fuel represents 9% of all source energy consumed, and 12% of all energy costs. The amount of boiler fuel consumed annually varies with the number of curtailments that occur. These curtailments have been minimal since FY 80, with the major curtailments occurring from FY 76 to FY 79 inclusive.

### 3.2.3 Petroleum Fuels

Gasoline and diesel fuel are consumed by the base's passenger vehicles, trucks, railroad equipment, heavy equipment (e.g., tractors, bulldozers, forklifts), lawnmowers, etc. Historically, these fuels supplied 12% of McAAP's source energy needs, and represented 28% of all energy costs. Since 1975, gasoline consumption has decreased about 30%, while diesel consumption has remained fairly constant. The annual use and cost for boiler fuel, gasoline, and diesel are shown in Figures I-9 through I-11.

3.2.4 Insignificant amounts of propane gas have been utilized until its use was curtailed in FY 81.

## 3.3 Energy Cost

Since FY 75, energy costs have quadrupled on a dollar per source BTU basis. This is a result of continuous cost increases in all energy sources: electricity, natural gas, diesel and gasoline. In recent months, McAAP has experienced significant increases in the unit costs of energy for both electricity and natural gas, while diesel and gasoline have remained relatively constant.

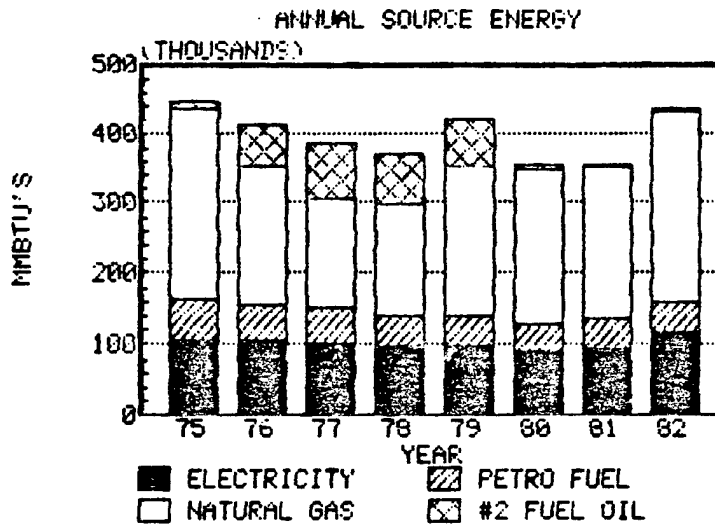

FIG. I-1

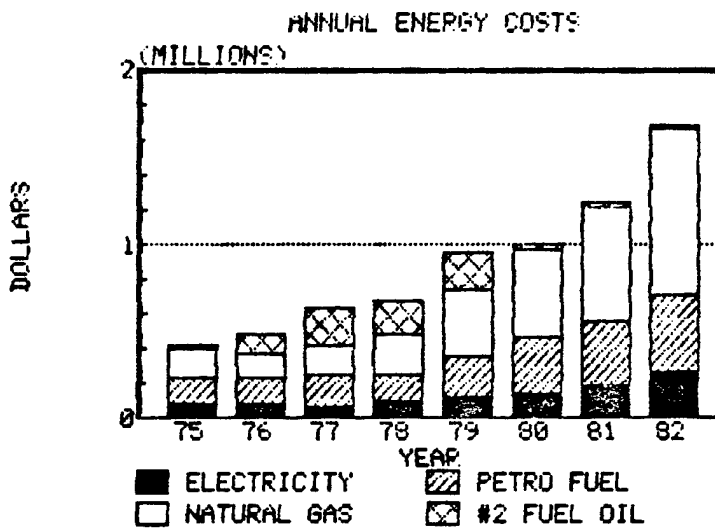

FIG. I-2

SOURCE ENERGY CONSUMPTION  
FY75 TO FY82

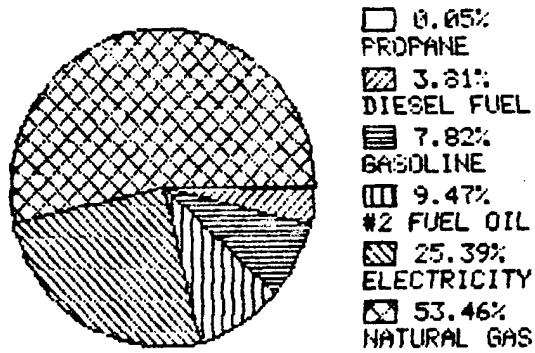

FIG I-3

ENERGY COSTS  
FY75 TO FY82

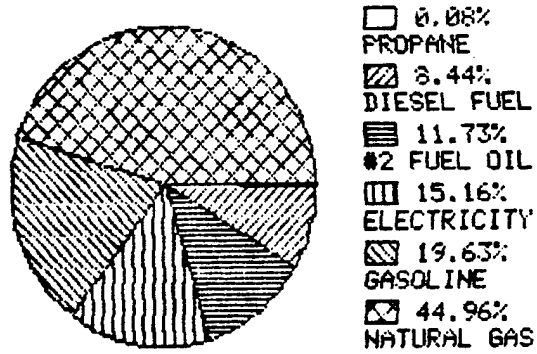

FIG I-4

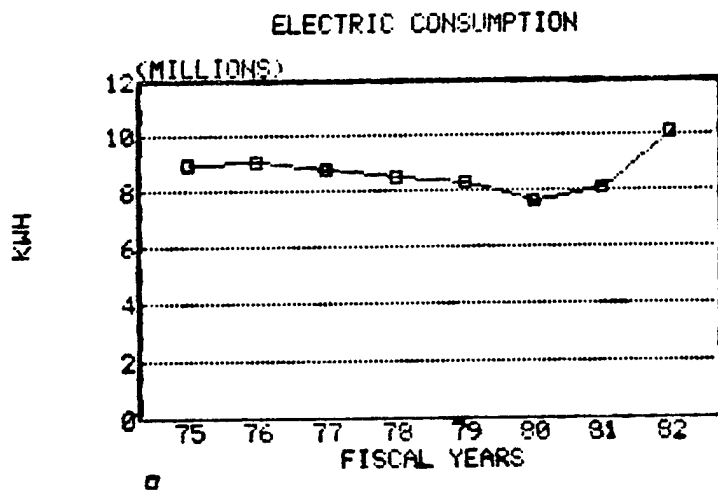

FIG. I-5

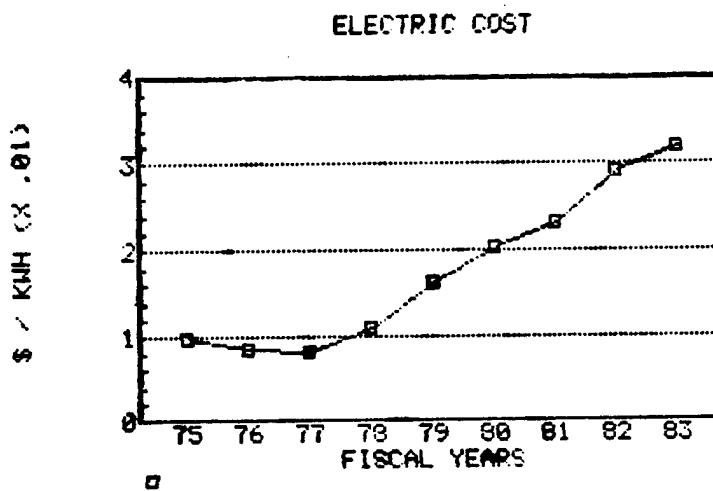

FIG. I-6

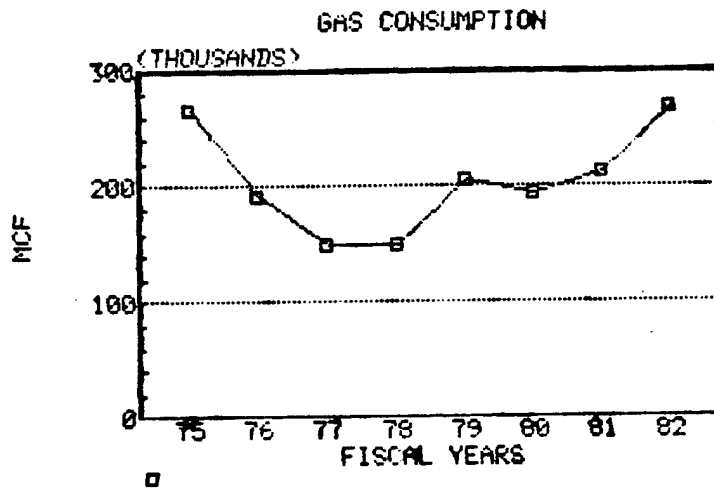

FIG. I-7

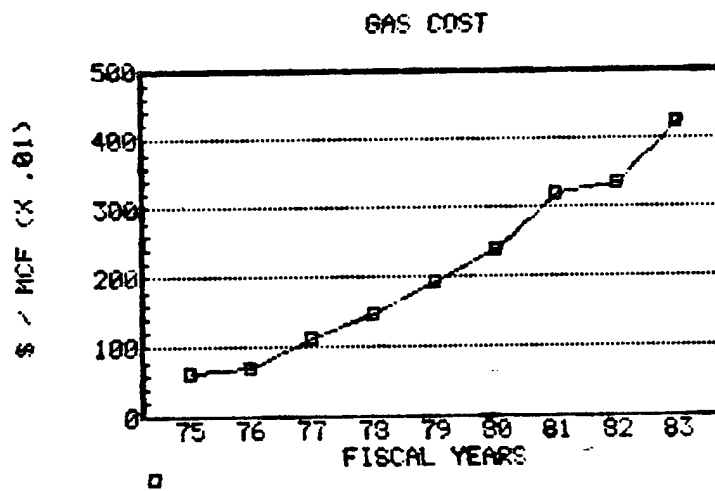

FIG. I-8

# PETROLEUM FUEL USE

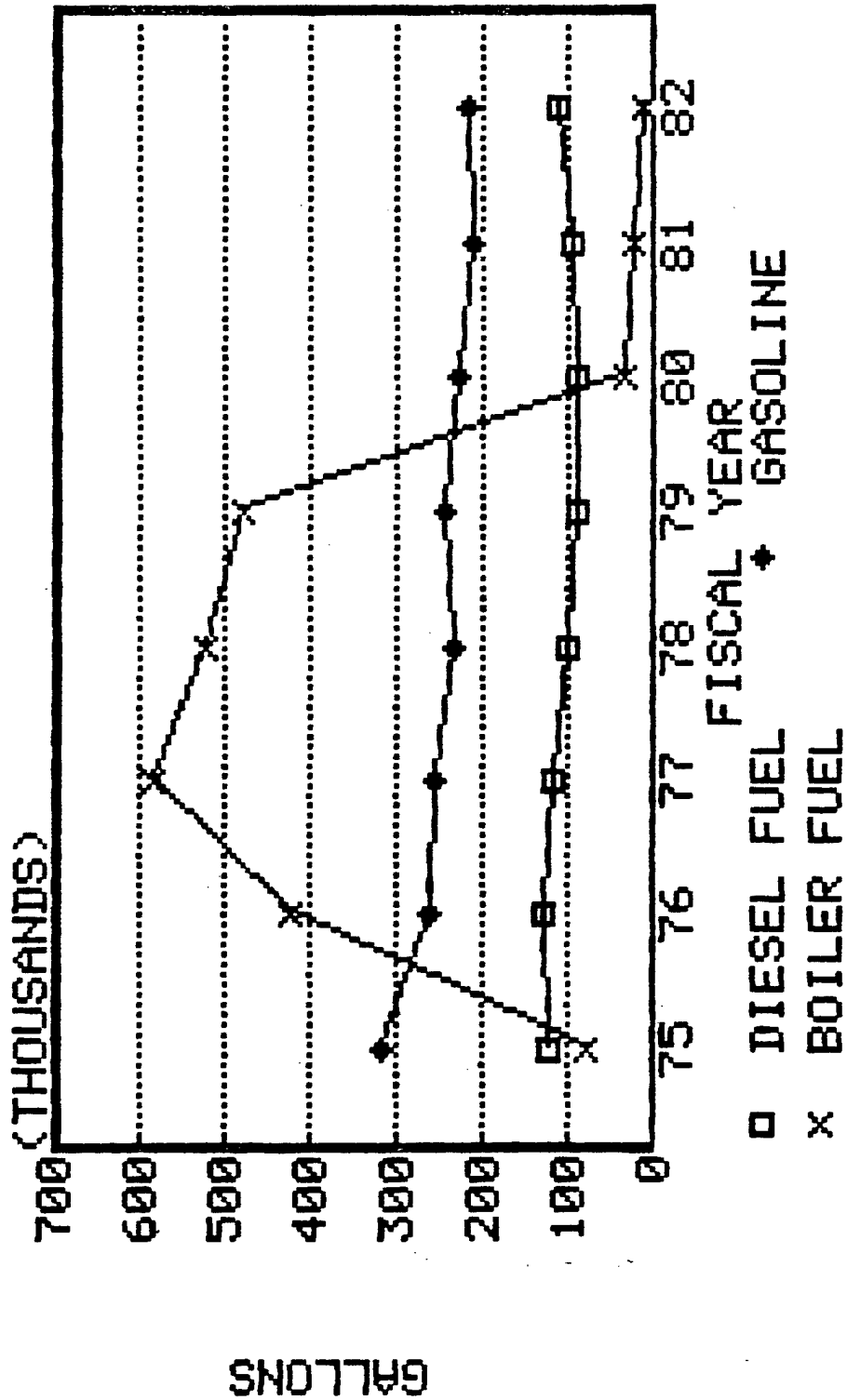

FIG. I-9

# LIQUID FUEL COSTS

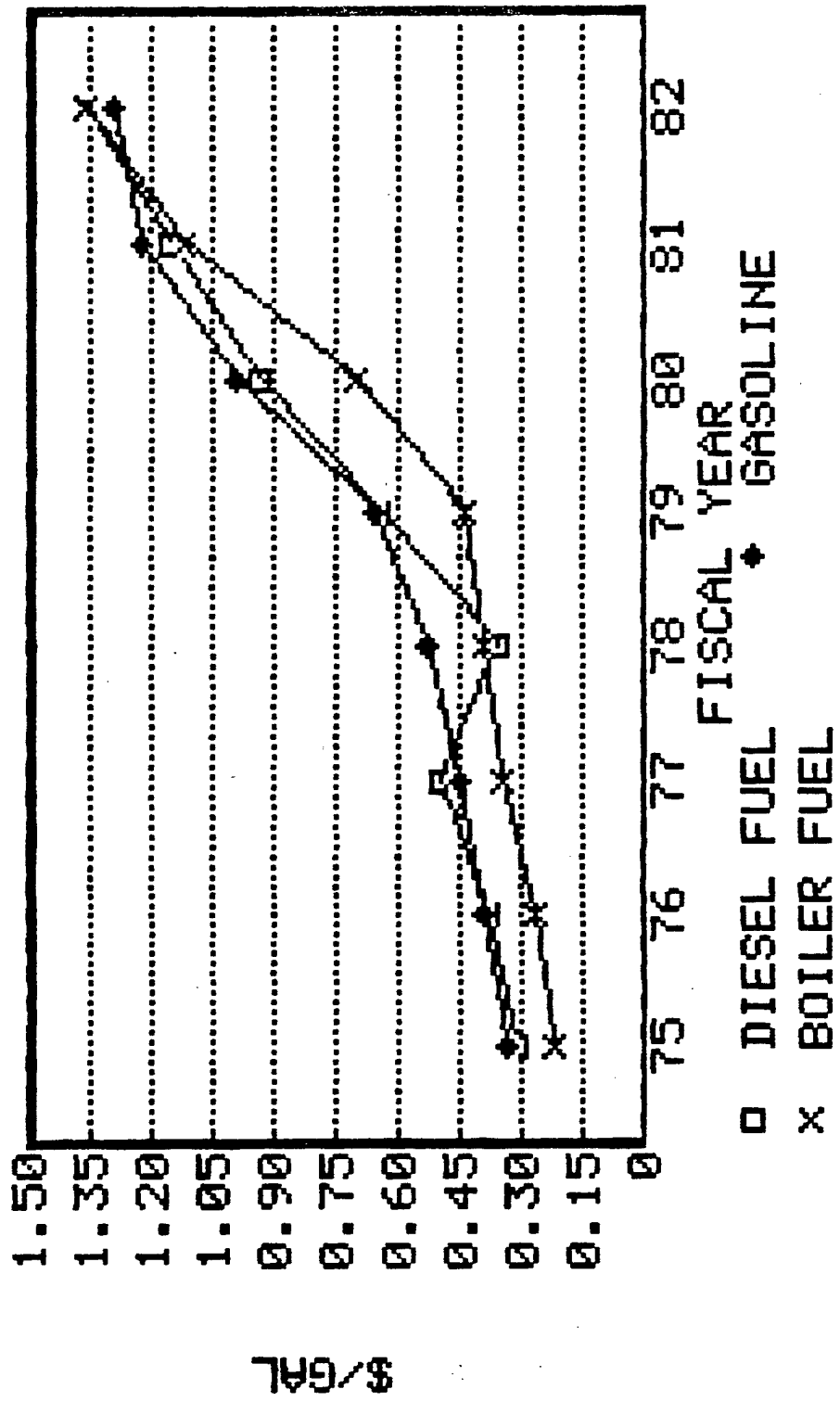

FIG. I-10

# TOTAL PETROLEUM FUEL COST

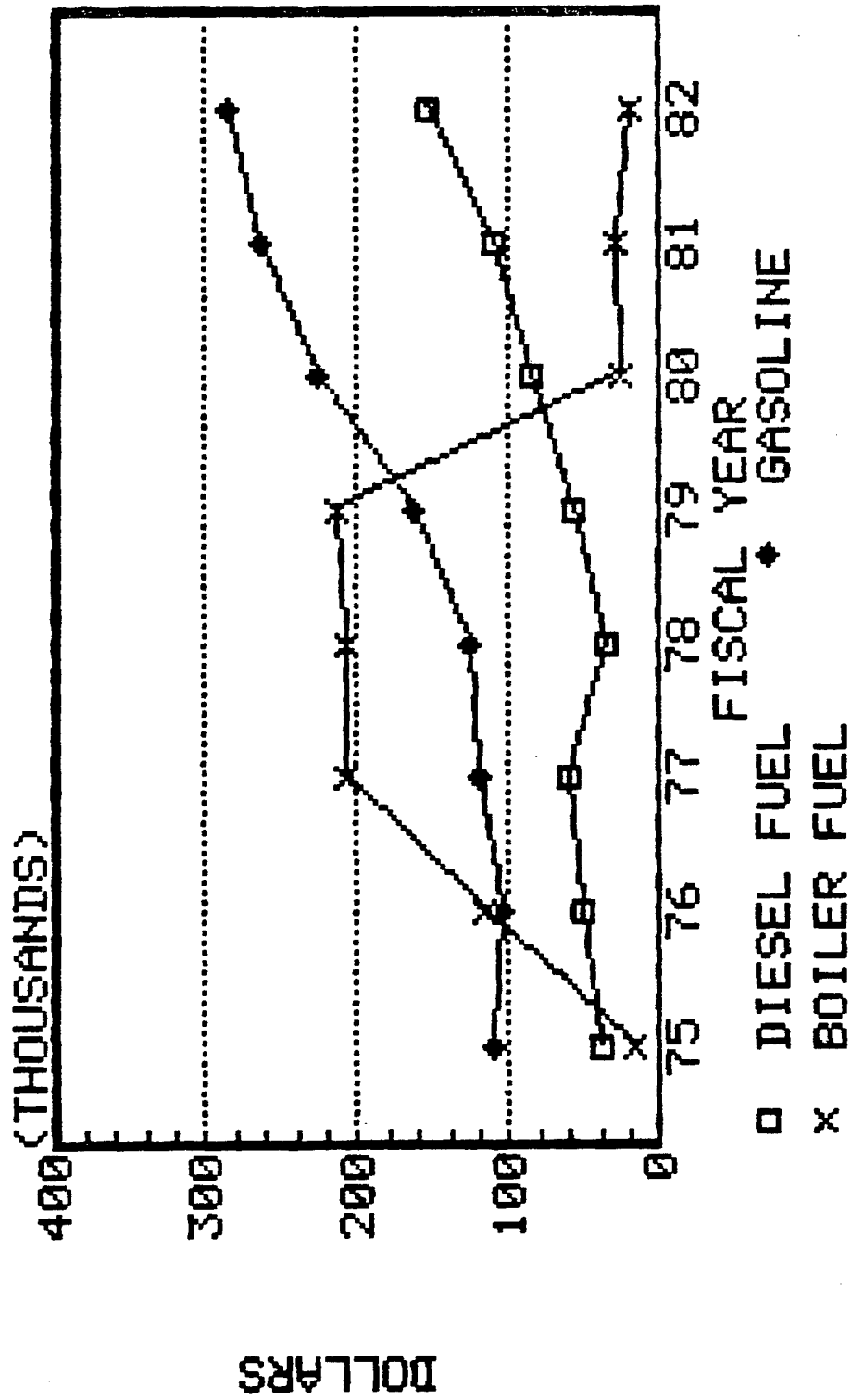

FIG. I-11

#### 4. FY 82 ENERGY ANALYSIS

##### 4.1 Overview

This section provides a summary of the installation's source energy consumption and costs for FY 82. It also itemizes by function the major energy consumers on base, with breakdowns for building groups, typical buildings, utility plants, and processes.

A utility cost analysis will be found in the following subsection. It provides more detail on the actual payments that are incurred for the energy used.

##### 4.2 Summary of Source Energy and Costs

4.2.1 In FY 82, McAAP consumed 440,954 MMBTU's of source energy at a cost of \$1,710,717.00. These amounts are itemized as follows:

	ANNUAL CONSUMPTION	SOURCE ENERGY MMBTU's	ANNUAL COST
Electricity	10,132,320 KWH	117,535	\$ 297,986
Natural Gas	269,934 MCF	278,302	\$ 952,547
Boiler Fuel	14,154 GAL	1,962	\$ 19,391
Gasoline	220,122 GAL	27,515	\$ 284,743
Diesel Fuel	114,282 GAL	<u>15,640</u>	<u>\$ 156,048</u>
Totals		440,954	\$1,710,717

4.2.2 This data is also summarized graphically in figures I-12 and I-13. A monthly breakdown of energy use and cost is provided in figures I-14 and I-15.

4.2.3 Based on this information, a few conclusions can be made.

1. Natural gas provides the greatest portion of energy needs and represents the largest utility cost.
2. The majority of the natural gas is used during the winter months and can be related to thermal loads.

3. On a monthly basis, electrical energy consumption is relatively constant. Electricity used from the period of November through February is only 1.4% less than that used from June through September. Therefore, a large amount of electrical energy is more related to constant loads such as lighting and processes rather than air-conditioning systems. Costs change on a monthly basis due to the varying mixture of hydro and thermal electric energy.
4. Gasoline and diesel fuel represent only 10% of the installation's source energy consumption, but 26% of the annual utility cost. Small reductions in vehicle consumption would provide noticeable cost savings. Further discussion will be found in the following subsection of the Executive Summary.

SOURCE ENERGY CONSUMPTION  
FY82

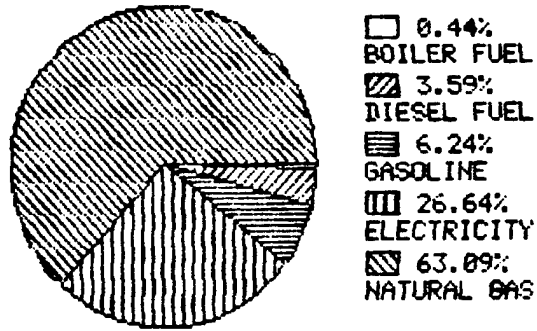

FIG. I-12

ENERGY COSTS  
FY82

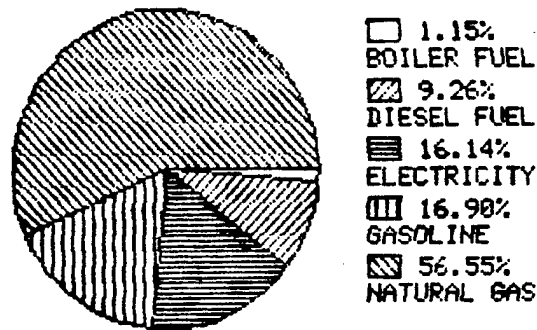

FIG. I-13

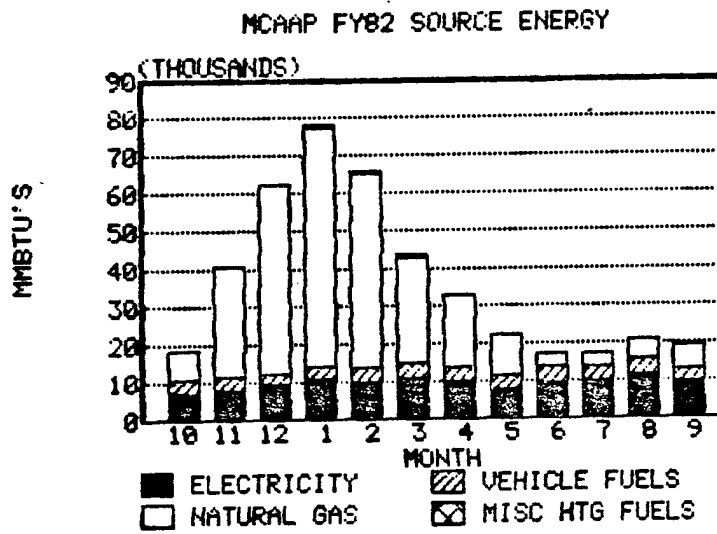

FIG. I-14

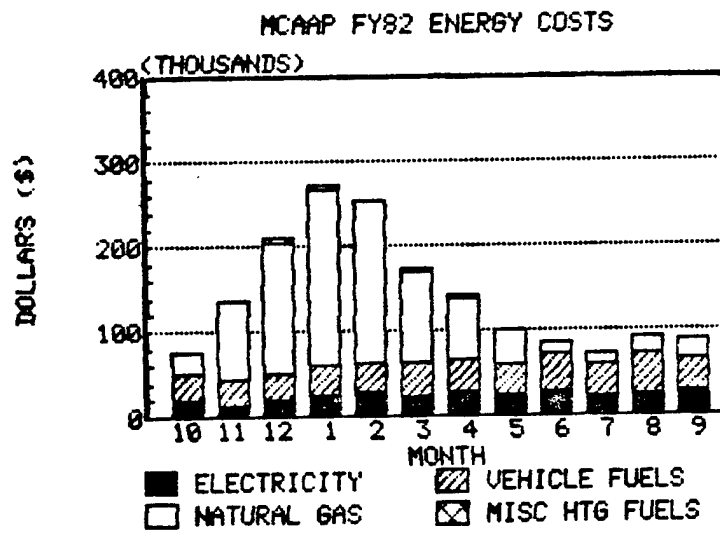

FIG. I-15

## 4.3 Installation Energy Consumption

### 4.3.1 Introduction

4.3.1.1 The installation's energy users are categorized into five groups.

1. Utility Plants and Electrical Distribution Systems
2. Ammunition Production Facilities
3. Other Facilities, including Installation Support (administrative buildings and industrial shops) and Tenants (those facilities not directly related to the Army's mission at McAAP).
4. Vehicles and Heavy Equipment

4.3.1.2 A general breakdown of the energy consumed by these groups can be found in Figure I-16.

4.3.1.3 The remainder of this section summarizes and itemizes energy estimates for typical building groups and typical building types. Due to the insufficient number of electrical and natural gas meters, estimates are based on field survey data, calculations, and computer simulations. Related information can be found in Volume V.

### 4.3.2 Utility Plants and Electrical Distribution Systems

4.3.2.1 The primary utilities that consume energy are the sewage and water treatment plants, street lighting, and transformers which create losses in the electrical distribution system. All of these loads, combined, use about 17% of the electrical energy, equivalent to 5% of all source energy consumed.

4.3.2.2 The treatment plants utilize electricity to meet pumping requirements.

4.3.2.3 Street lighting consists of mercury vapor lamps that primarily operate in areas of high use and/or traffic.

4.3.2.4 There are over 300 oil-cooled transformers on base, totalling almost 20,000 KVA of connected capacity, plus 3 substation transformers rated at 2500 KVA each. Although oil-cooled transformers are efficient, the high number of

transformers operating at a very low percentage of their rated capacity results in a significant energy use.

- 4.3.2.5 The electrical consumption of these items are graphically represented in Figure I-16.

# FY 82 ENERGY CONSUMPTION

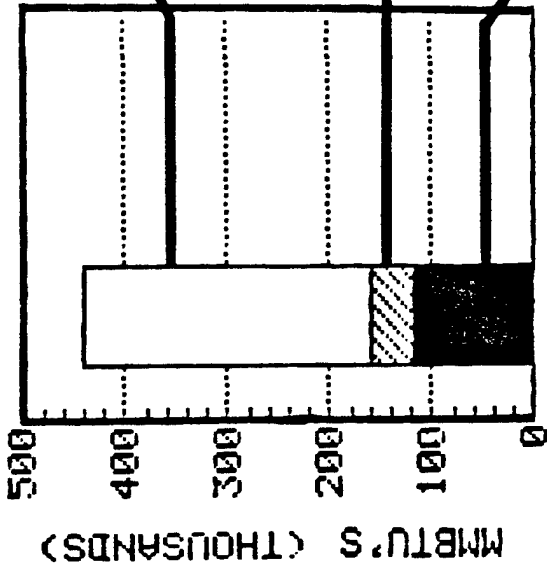

## SOURCE

- ELECTRICITY
- NATURAL GAS
- ▨ VEHICLE FUEL
- MISC Htg. FUEL

- 1.96% STANDBY LOSSES
- ▨ 3.73% H.P. STEAM TRAPS
- ▨ 8.77% H.U. PREHEAT
- ▨ 16.44% PROCESS LOADS
- ▨ 19% FLUE GAS LOSSES
- ▨ 19.85% DISTRIBUTION
- ▨ 31.85% BLDG HEATING

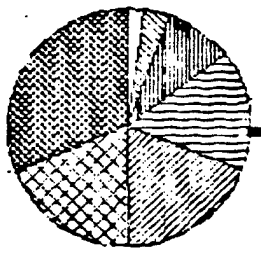

## STEAM PROCESSES

- 9.64% MELT-HX 177/100
- ▨ 25.87% LAUNDRY 129-8
- ▨ 66.29% STEAM OUT 106

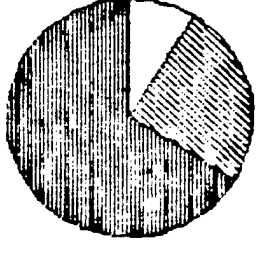

## VEHICLE FUELS

- 26.81% GAS AUTOMOBILES
- ▨ 34.17% DIESEL RR/HAY
- ▨ 39.82% GAS HEAVY EQUIP

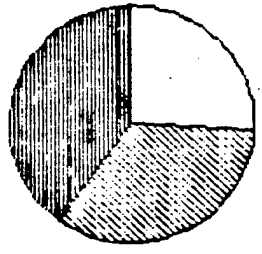

## ELECTRICITY

- 3.32% STREET LIGHTING
- ▨ 3.80% SEWAGE TREATMENT
- ▨ 4.51% WATER PLANT
- ▨ 7.69% TX LOSSES
- ▨ 22.55% SUPPORT
- ▨ 22.65% TENANTS
- ▨ 35.48% PRODUCTION

## PRODUCTION ELECTRICAL

- 18.98% MOTORS
- ▨ 15.39% BOILER MOTORS
- ▨ 20.88% BATTERY CHARGE
- ▨ 22.76% LIGHTING
- ▨ 38.79% TAR MELT

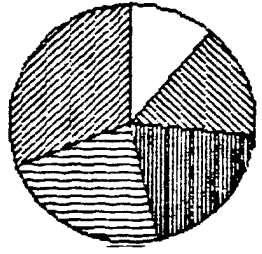

## TENANT ELECTRICAL

- 1.05% DP/DO
- ▨ 5.83% PX
- ▨ 8.39% MARINE BARRACKS
- ▨ 18.48% COMMUNITY FAC.
- ▨ 16.35% NAVAL WEAPONS
- ▨ 19.71% RESID/BARRACKS
- ▨ 38.99% PLANT CONST.

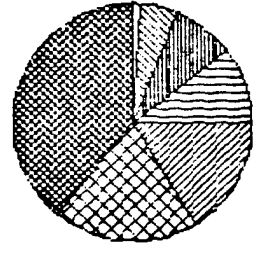

FIG. 1 - 16

### 4.3.3 Ammunition Production Facilities

4.3.3.1 The production facilities used over 70% of the total base requirements for natural gas, 100% of the supplemental boiler fuel, and more than 40% of the electricity. Excluding vehicle fuel useage, this represents 65% of all source energy consumed at McAAP.

#### 4.3.3.2 Typical Production Plant and Buildings

##### 1. Natural Gas and Boiler Fuel

Each production area is serviced by a boiler plant that supplies steam for building heating and steam processes. There are 22 high pressure steam boilers located in 9 boiler plants, representing a total capacity of 6,600 HP of boiler output. This steam is delivered through a total of 13-1/2 miles of steam supply and condensate return lines. A schematic of a typical boiler plant is provided as Figure I-17. Figures I-18 to I-20 provide a breakdown of natural gas usage in the boiler plants.

##### 2. Steam Consumption

Building heating requirements account for the majority of actual steam usage. The remainder is mainly consumed by three processes.

1. The Steam-out process in Bldg. #186, Bomb and Mine Area; rated at 9200 pounds per hour. Condensate is contaminated by the process and cannot be returned to the boiler plants.
2. Melt-mix kettles in Bldg. #177 for melting explosives; rated at 720 pounds per hour. Condensate is also contaminated and is not returned.
3. Laundry facility in Bldg. #129-B for cleaning the clothing worn by personnel in the production building.

### 3. Electricity

1. Electrical use in the production plants depends on the equipment that exists in the individual buildings. There are three major electrical loads, however, that can be identified.

1) The tar melt kettle in Bldg. #175; for bomb preparation; rated at 252 KW exclusive of agitator motors and pumps. The kettle must run continuously to keep asphalt in a molten state.

2) Battery charging in Bldg. #48; average load of 300 KW; Battery powered forklifts are used in lieu of combustion engines because of the explosive environments.

3) The boiler motors, including draft fans, atomizers, and feedwater pumps; these represent an approximate total of 500 KW.

2. The electrical use in the production building, is evenly divided between the explosion-proof incandescent lighting systems and the explosion-proof motors (e.g. air compressors, pumps, hoists, conveyors).

### 4. Typical Production Building Energy Use

Figures I-21 to I-23 summarize the annual energy requirements for typical production buildings, including a building which is placed on stand-by status.

While reviewing the figures pertaining to production facility energy use, the following issues deserve mention:

1. It would be very difficult to reduce the boiler flue gas losses. The measured operating efficiencies of the boilers equaled or exceeded manufacturer's ratings. McAAP's boilers are checked on a routine basis with a computerized flue gas analyzer.

2. McAAP has applied for funding for the replacement of some of the insulation on its steam lines. To date, this funding has not been approved. The A/E concurs with McAAP personnel on the need for steam line insulation and is recommending re-insulating a majority of the steam supply lines in Increment 'B'. With this project implemented, distribution losses will be reduced about 30%. The A/E is also recommending in Increment 'F' that the FE install new insulation on a replacement basis as old insulation becomes deteriorated. This would provide an additional 14% reduction in distribution losses over the next 15 to 20 years.
3. The A/E is recommending modifications to the distribution system that will significantly reduce the high pressure steam trap losses and the corresponding requirements for pre-heating boiler make-up water. This project is discussed under Increment 'G'.
4. If production buildings are to be retrofitted, their explosive environments will require that higher cost, explosion-proof equipment be installed. Furthermore, an explosive environment excludes the building from being retrofitted with insulating materials because of their inherent static properties or other functional problems.

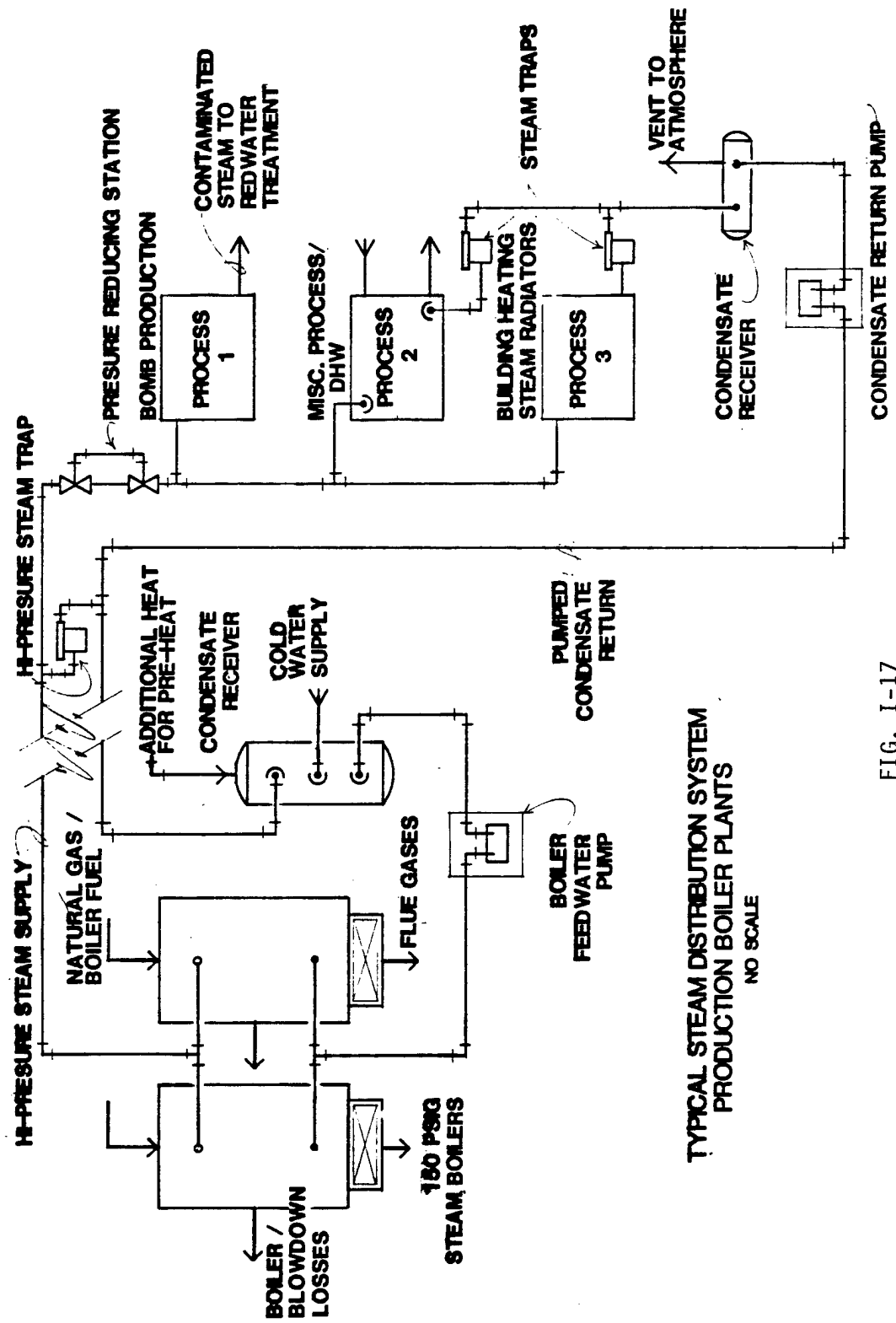

TYPICAL STEAM DISTRIBUTION SYSTEM  
 PRODUCTION BOILER PLANTS  
 NO SCALE

FIG. I-17

PRODUCTION BOILER PLANT

MCF

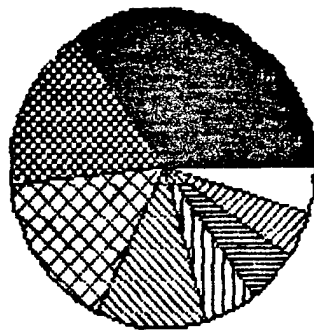

- 4.60%
- 165B: 20MM
- ▨ 4.81%
- 136B: MEDCAL
- ▩ 5.49%
- 108&110B: MAJCAL
- ▧ 5.69%
- 141B: MEDCAL
- ▦ 11.59%
- 105B: 40MM
- ⊠ 16.27%
- 129B: MEDCAL
- ⊞ 16.98%
- 229B: ROCKET
- 34.57%
- 185B: B&M PLANT

FIG. I-18

TYPICAL BOILER PLANT 185B

MMBTU'S

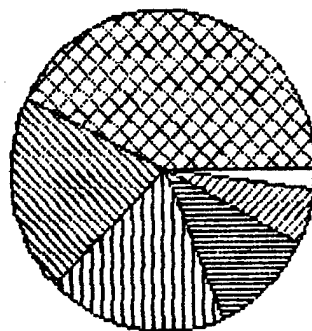

- 1.97%
- STNDBY LOSSES
- ▨ 5.54%
- HP STM TRAPS
- ▩ 11.09%
- M.U. PREHEAT
- ▧ 19.06%
- FLUE LOSSES
- ▦ 19.98%
- DISTRIBUTION
- ⊠ 42.36%
- BLDG HEATING

FIG. I-19

BOILER PLANT 185B

MMBTU'S

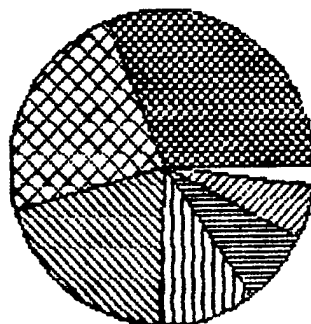

- 1.97%
- STNDBY LOSSES
- ▨ 5.59%
- HP STM TRAPS
- ▩ 7.81%
- COND. LOSSES
- ▧ 9.92%
- DISTRIBUTION
- ▦ 20.44%
- FLUE LOSSES
- ⊠ 23.42%
- BLDG HEATING
- ⊞ 30.85%
- M.U. PREHEAT

FIG. I-20

TYP PRODUCTION BUILDING  
176590 SOURCE BTU/SQFT/YR

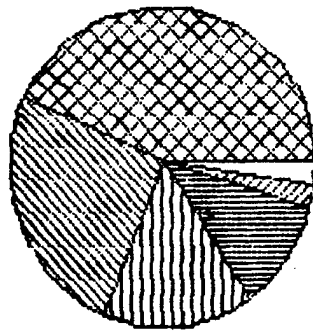

- 2.16%  
STM:TRAP LOSSES
- ▨ 2.23%  
STM:DHW
- ▩ 10.93%  
STM:AIR INFILT
- ▧ 16.01%  
STM:DOCK DOORS
- ▦ 25.41%  
ELEC:LIGHTING
- ▤ 43.26%  
STM:HTG TRNSM

FIG. I-21

PROD BLDG W/ ELEC MOTORS  
283850 SOURCE BTU/SQFT/YR

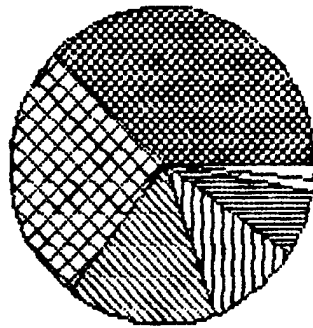

- 1.35%  
STM:TRAP LOSSES
- ▨ 1.39%  
STM:DHW
- ▩ 6.80%  
STM:AIR INFILT
- ▧ 9.96%  
STM:DOCK DOORS
- ▦ 15.81%  
ELEC:LIGHTING
- ▤ 26.92%  
STM:HTG TRNSM
- ▣ 37.77%  
ELEC:MOTORS

FIG. I-22

TYP PROD BLDG ON STANDBY  
60040 SOURCE BTU/SQFT/YR

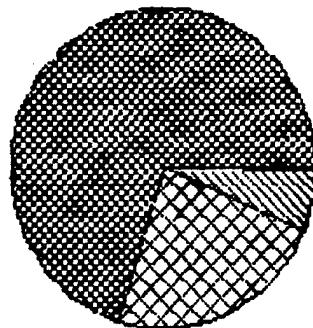

- 0%  
STM:DOCK DOORS
- ▨ 0%  
STM:DHW
- ▩ 0%  
ELEC:LIGHTING
- ▧ 0%  
ELEC:MOTORS
- ▦ 6.32%  
STM:TRAP LOSSES
- ▤ 23.70%  
STM:AIR INFILT
- ▣ 69.98%  
STM:HTG TRNSM

FIG. I-23

#### 4.3.4 Other Facilities

- 4.3.4.1 The administrative buildings, industrial shops, and tenants such as the residences, barracks, and Naval Special Weapons accounted for 30% of all source energy consumed on base, exclusive of vehicle fuels. This represents about 30% of all natural gas and 40% of all electrical energy. 25% of the electrical energy used by other facilities (10% of the total basewide electrical use) was used in the construction and testing of the Navy's Bomb and Mine 'A' Plant Modernization Project.

Figures I-24 to I-26 provide a summary of source energy consumption for the typical administrative office, industrial shop, and residence. Most of the energy is used by heating, air-conditioning, and lighting systems. A detailed description of these facilities, along with building systems and equipment, can be found in the appendix, Volume V.

#### 4.3.4.2 Tenants

1. Tenants are defined as those facilities which are not directly related to the Army's mission at McAlester. They include the residences and barracks, the retail exchange store, the bowling alley and gymnasiums, Defense Property Disposal (DPDO), the Marine Barracks, Naval Special Weapons, and the Navy's Bomb and Mine 'A' Plant Modernization Project.
2. Most tenants are required to reimburse the Army for energy used. Natural gas meters do not exist on these buildings and utility billings must be based on estimates. The A/E has reviewed these estimates and concludes that they are too low. Historically, the summer months have shown more natural gas consumption than predicted by energy models. This use is not related to building thermal loads, and it would have to be attributed to loads other than DHW heating. The A/E has conferred with McAAP engineers to determine what these loads might be. Suspect areas include the Naval Special Weapons incinerator, the Marine

Barrack's kitchen equipment, and other tenant loads.

3. To properly bill the tenants or to account for energy used, natural gas meters need to be installed, especially for Naval Special Weapon's, the PX, the Marine Barrack's, and the residential area. Metering tenants would also improve the accuracy of itemizing the energy consumed by the mission related facilities of the installation.
4. Another facility which should be considered as a partial tenant is the water treatment plant. A large portion of the water produced by the plant is sold to the near-by town of Savannah, Oklahoma. The billing procedures should be evaluated on a regular basis to insure that the appropriate electrical energy and demand charges are included in the total cost. If necessary, an electrical meter should be installed.

#### 4.3.5 Petroleum Fuels

Gasoline and diesel fuels represented only 10% of the FY 82 source energy consumed, but 26% of the total annual energy costs. A few recommendations are provided below:

1. A more definitive documentation method for the consumption of petroleum fuels should be created. Currently a very detailed accounting procedure is used to itemize gasoline consumed by passenger vehicles and large trucks. (See Figure I-27 on the following page). This represents 40% of all gasoline used. It is not clear where the other 60% goes; some is used by heavy equipment, some by reserve vehicles, some is kept in storage tanks. This was reviewed with McAAP personnel, but no additional information could be obtained. More accurate accounting will help determine where gasoline and diesel consumption can be cut.

TYP ADMINISTRATION BLDG  
187200 SOURCE BTU/SQFT/YR

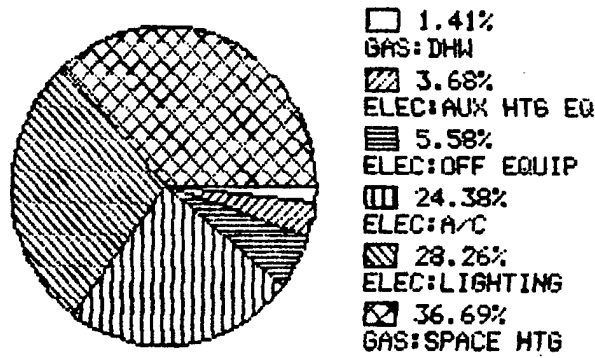

FIG. I-24

TYP INDUSTRIAL SHOP  
176800 SOURCE BTU/SQFT/YR

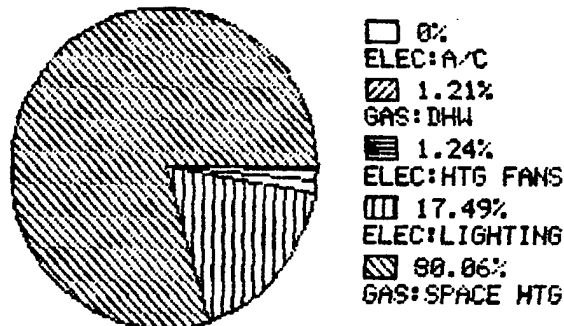

FIG. I-25

TYPICAL RESIDENCE (SFD)  
173500 SOURCE BTU/SQFT/YR

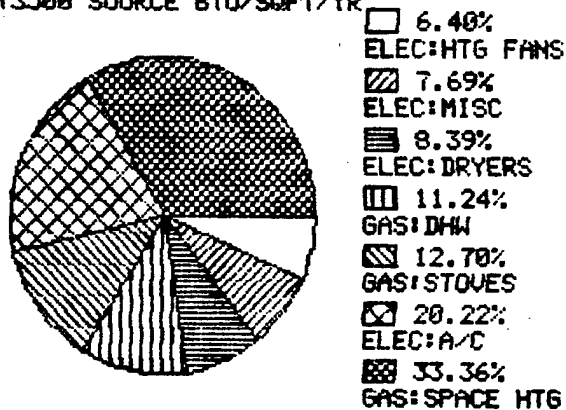

FIG. I-26

2. Some diesel is used by the "burn-out" process in building #452, where ammunition rounds are destroyed. McAAP personnel are currently studying the possibility of using natural gas for this process. With the expectation of natural gas becoming available at well head costs, it is recommended that a switch to natural gas be pursued. (On-site natural gas is discussed in subsection 6.2 of the Executive Summary.)
3. Passenger cars and small trucks with gasoline engines, when disposed of, should be replaced with diesel. This information is based on the following information:
  - 1) The initial cost is not significantly greater than those with gasoline engines.
  - 2) Diesel engines consume 25% to 50% less fuel per mile, and have a life expectancy of 200,000 miles compared to 100,000 miles for gasoline engines.
  - 3) Diesel engines require more routine maintenance, but require less maintenance for major overhauls.

To make this recommendation feasible, fewer vehicles should be used to increase the annual mileage per vehicle. Currently, the average vehicle is operated for 600 miles a year. Because of the longer life of a diesel engine, the life cycle costs are more attractive only if their usage is in excess of 20,000 miles a year.



## 5. FY 82 UTILITY ANALYSIS

### 5.1 Overview

This section describes more completely the utility rate structures and itemizes the monies paid by McAAP for electricity and natural gas. This discussion is based on the rate schedules in effect for FY 82.

### 5.2 Electricity

- 5.2.1 Electrical energy is sold to the base through the Southwestern Power Assoc., or SWPA, a Federal Agency. SWPA's principal purpose is to regulate the production and sale of hydro-electric energy to its contract customers, generally other Federal Agencies. The amount of hydro-energy available is determined monthly according to a pre-set formula based on the total amount of hydro-energy generated in the SWPA system. McAAP's contract with SWPA entitles McAAP to approximately 2.6% of all hydro-electric energy produced by SWPA.
- 5.2.2 To augment the hydro-electric energy, SWPA also provides thermally generated electricity. SWPA purchases this energy from Public Service of Oklahoma (or PSO) under a separate long-term contract. SWPA passes these thermal costs directly to its customers without any mark-up. These costs are referred to by SWPA as reimbursable costs, and they include both demand and energy components.
- 5.2.3 McAAP's contract with SWPA is based on a peak demand of 2688 KW. SWPA is responsible for providing McAAP with all its electrical needs, either from hydro-electric or thermal-electric energy and power sources as long as the maximum demand remains at or below 2688 KW.
- 5.2.4 According to McAAP's contract with SWPA, the monthly demand costs paid are fixed. McAAP pays directly to SWPA a \$1.95 per month per KW for hydro-power and \$1.787 per month per KW for thermal power to reimburse SWPA for monies paid to PSO. This results in a total monthly demand cost of \$10,045.06.  $((1.95 + 1.787) \times 2688)$
- 5.2.5 Hydro-electric energy supplied 30% of McAAP's electrical requirements, approximately 3,000,000 KWH at a total cost of approximately \$10,500.00 (\$0.0035 per KWH). The remainder was thermally generated energy purchased at a cost of approximately \$152,280.00 (FY 82 average of \$0.022 per KWH).

- 5.2.6 SWPA also penalizes McAAP for power factors below 95%. For each 1% the average monthly power factor is below 95%, SWPA increases McAAP's total electric costs, (the sum of SWPA's demand costs, hydro-electric and thermal-electric energy costs) by 1%. The power factor penalty for FY 82 amounted to approximately \$20,400.00, 7.5% of the total electric cost.
- 5.2.7 If the 2688 KW demand is exceeded, McAAP must purchase supplemental energy directly from PSO. The costs are based on PSO's standard rate schedules. Once the 2688 KW demand level is surpassed, McAAP is also required to purchase supplemental energy from PSO for another 11 months past the last month in which the 2688 KW level was exceeded (12 month "ratchet" clause).
- 5.2.8 The energy cost, in units of \$ per KWH, that is paid directly to PSO for supplemental energy is approximately the same as that paid to SWPA for thermal energy. The only significant, incremental cost penalty has been a monthly demand cost of \$450.00 (\$470.00 during peak months) throughout FY 83. This is because McAAP's electrical demand exceeded the 2688 KW limit by 88 KW in July of 1982. This has resulted in an additional annual cost of \$5,480.00 for FY 83.
- 5.2.9 A breakdown of annual electric energy use and utility costs are provided in Figures I-28 to I-31.
- 5.2.10 Electrical Profiles are provided as Figures I-32 to I-41. They include electrical demand profiles for typical months, weeks, and days of the year. Also included are typical power factor profiles.
- 5.2.11 Electrical Cost Analysis
- For the purpose of this study, electric costs will be taken as the cost of the last kilowatt hours used, since this would be the first to be avoided under any energy conserving scheme. In this case, this will be the thermal power, at a current FY 83 cost of \$0.029 per KWH.

FY82 ELECTRIC ENERGY

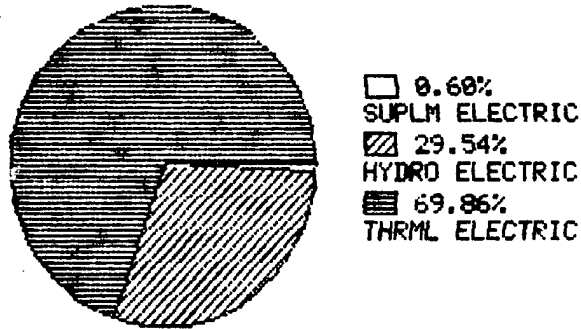

FIG I-28

FY82 ELECTRIC COSTS

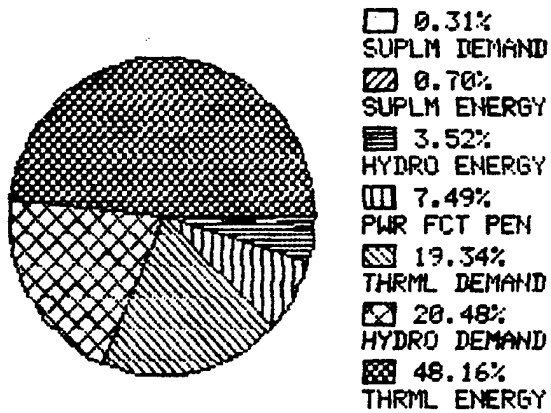

FIG. I-29

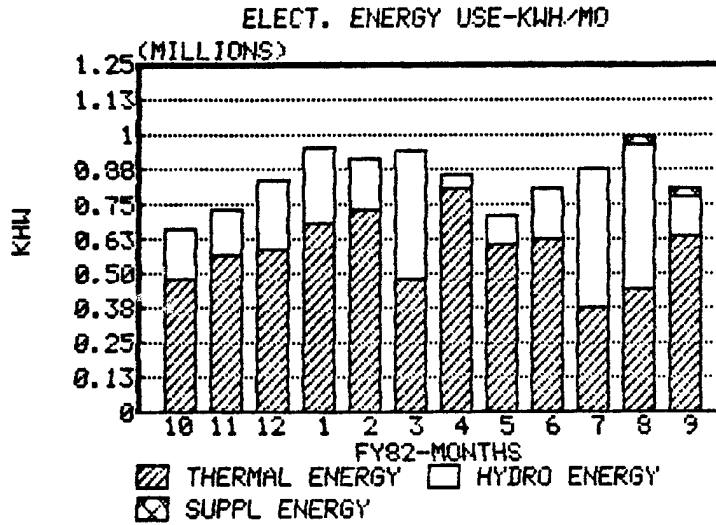

FIG. I-30

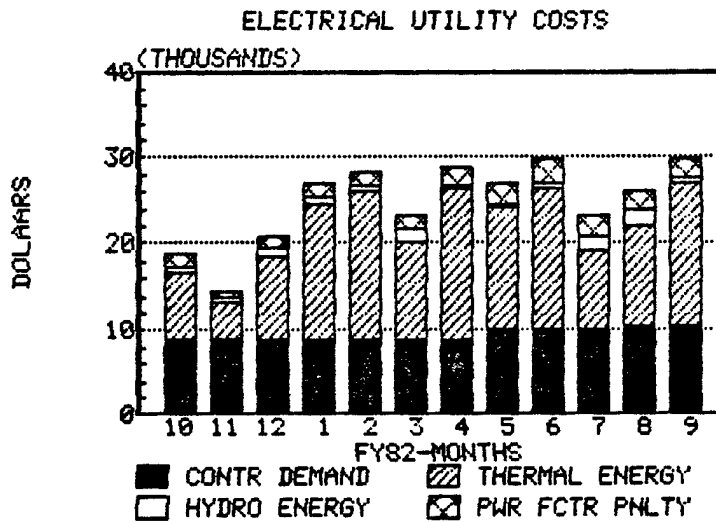

FIG. I-31

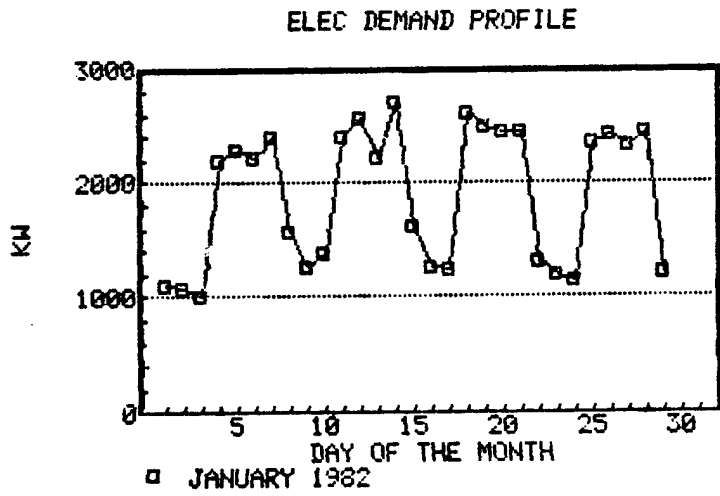

FIG. I-32

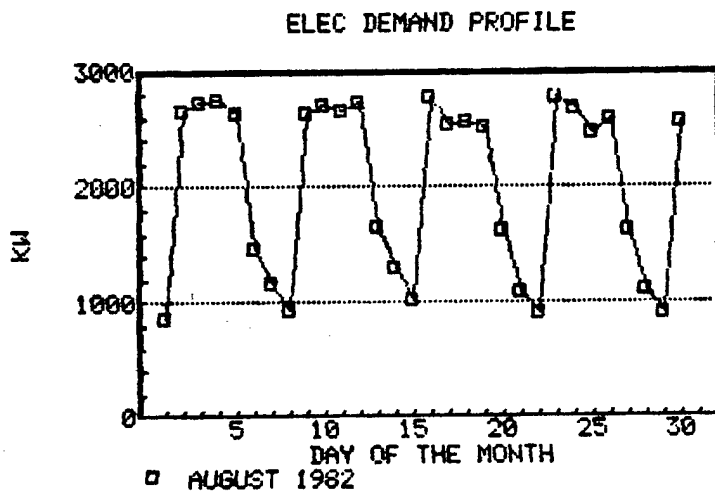

FIG. I-33

# TYPICAL WEEK ELEC PROFILE

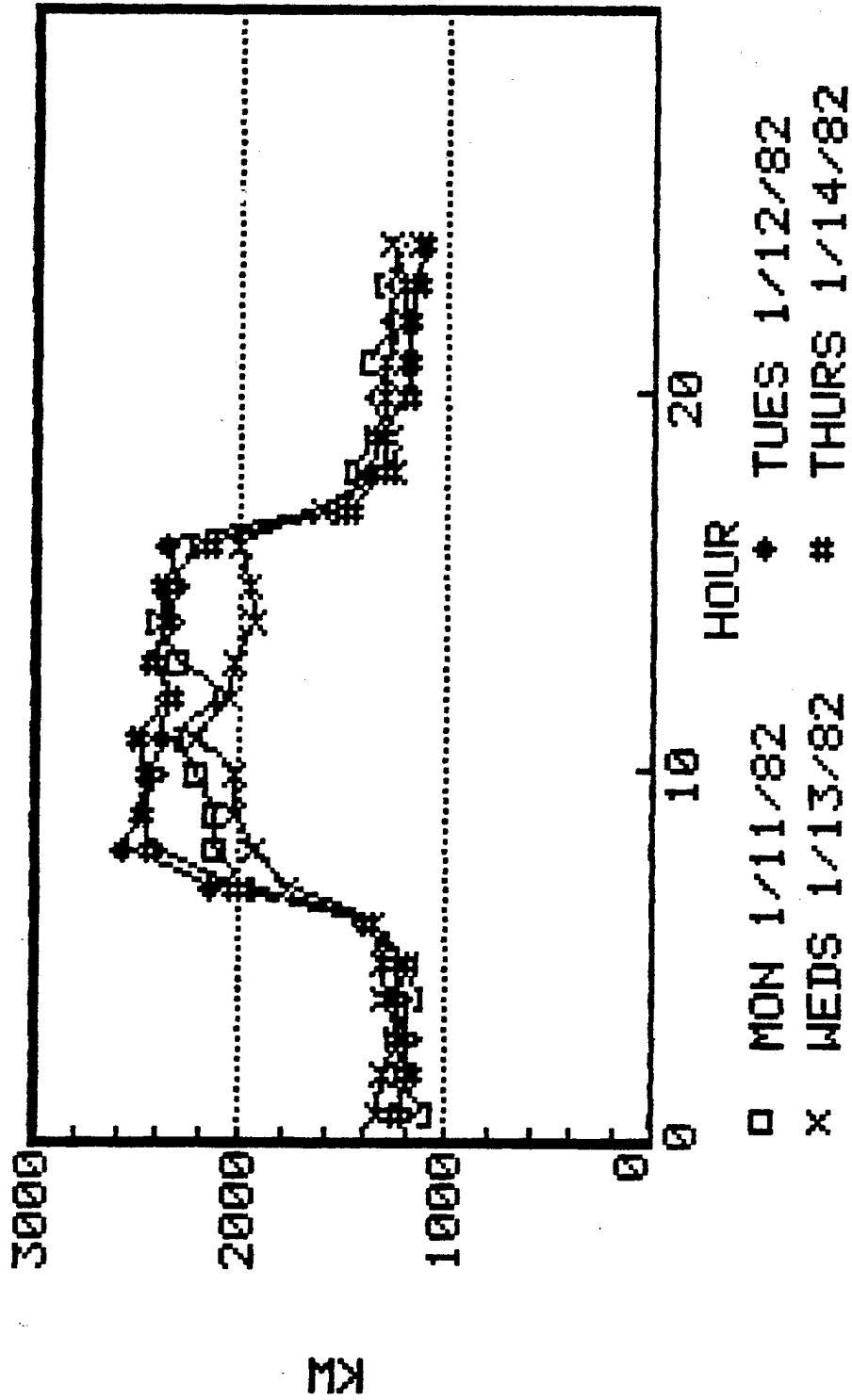

FIG. I-34

# TYPICAL WEEK ELEC PROFILE

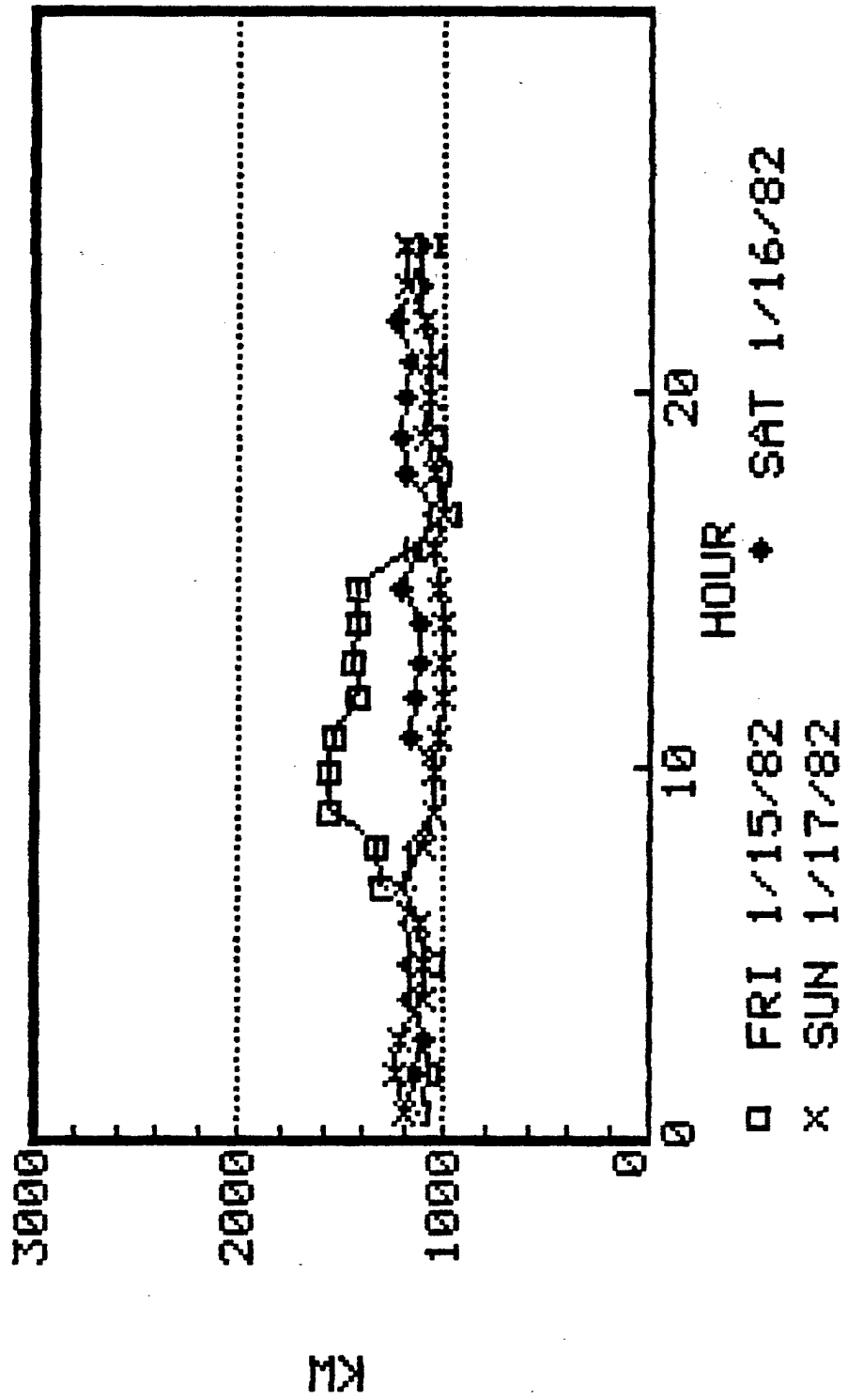

FIG. I-35

# TYPICAL WEEK ELEC PROFILE

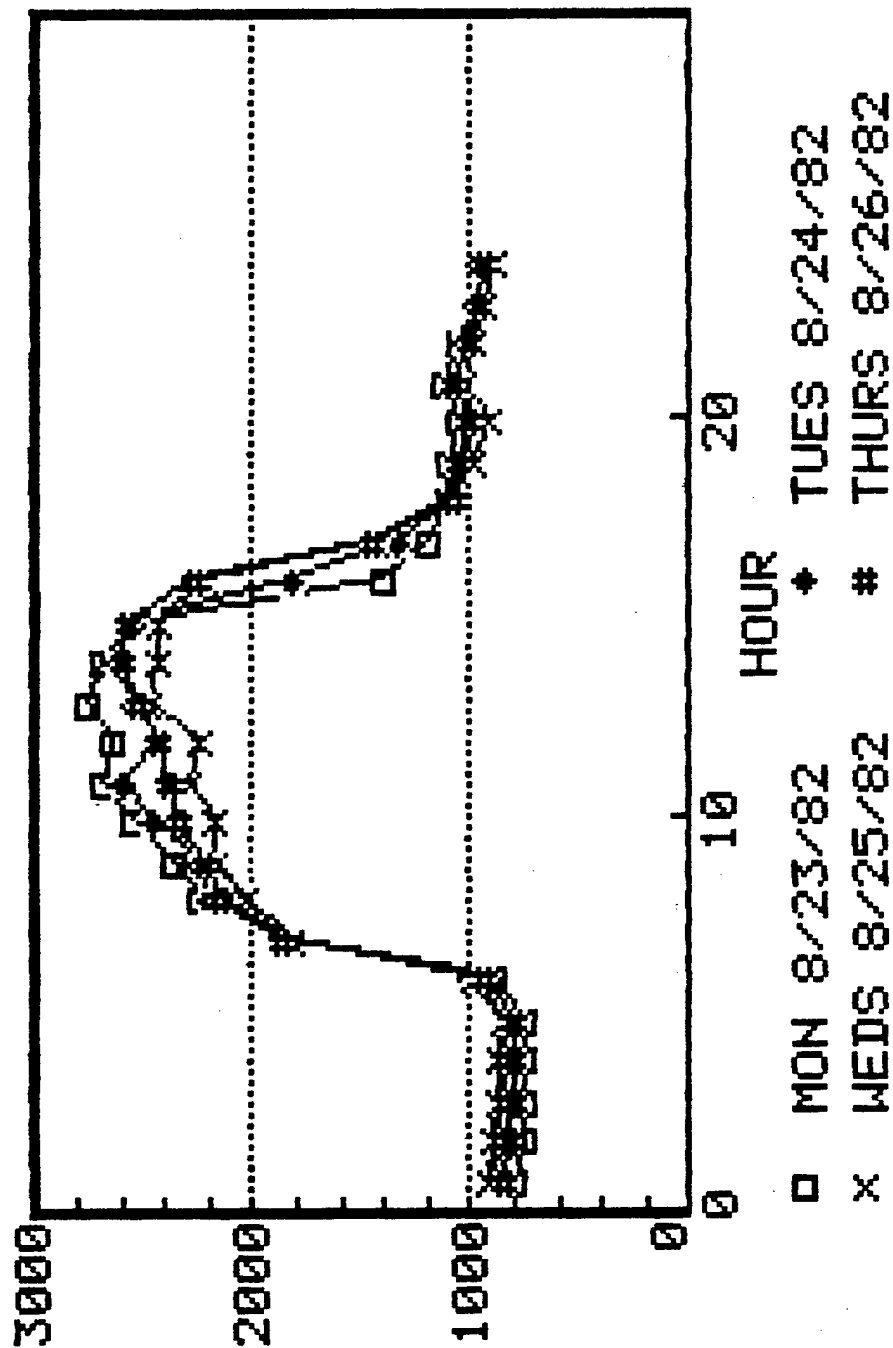

FIG. I-36

# TYPICAL WEEK ELEC PROFILE

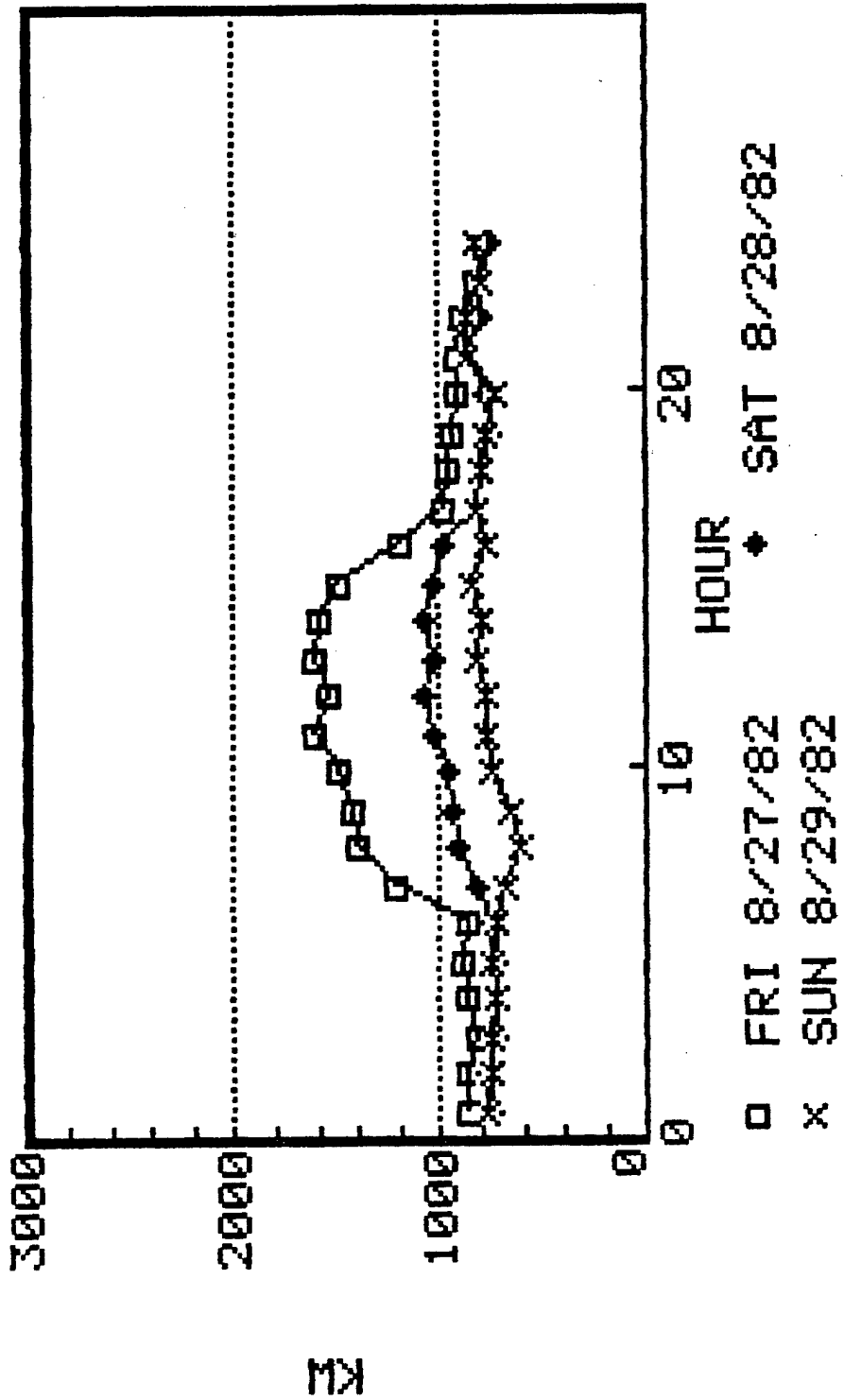

FIG. I-37

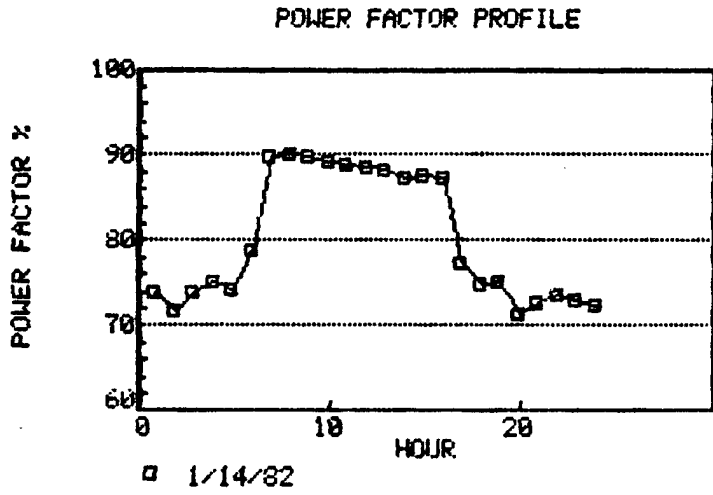

FIG. I-38

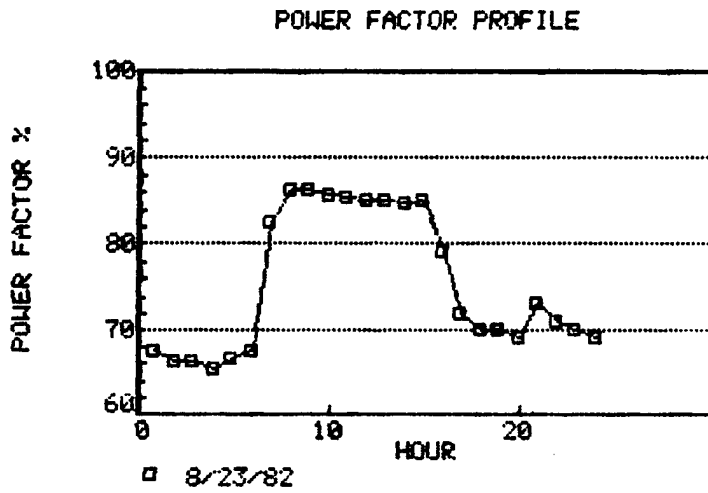

FIG. I-39

POWER FACTOR

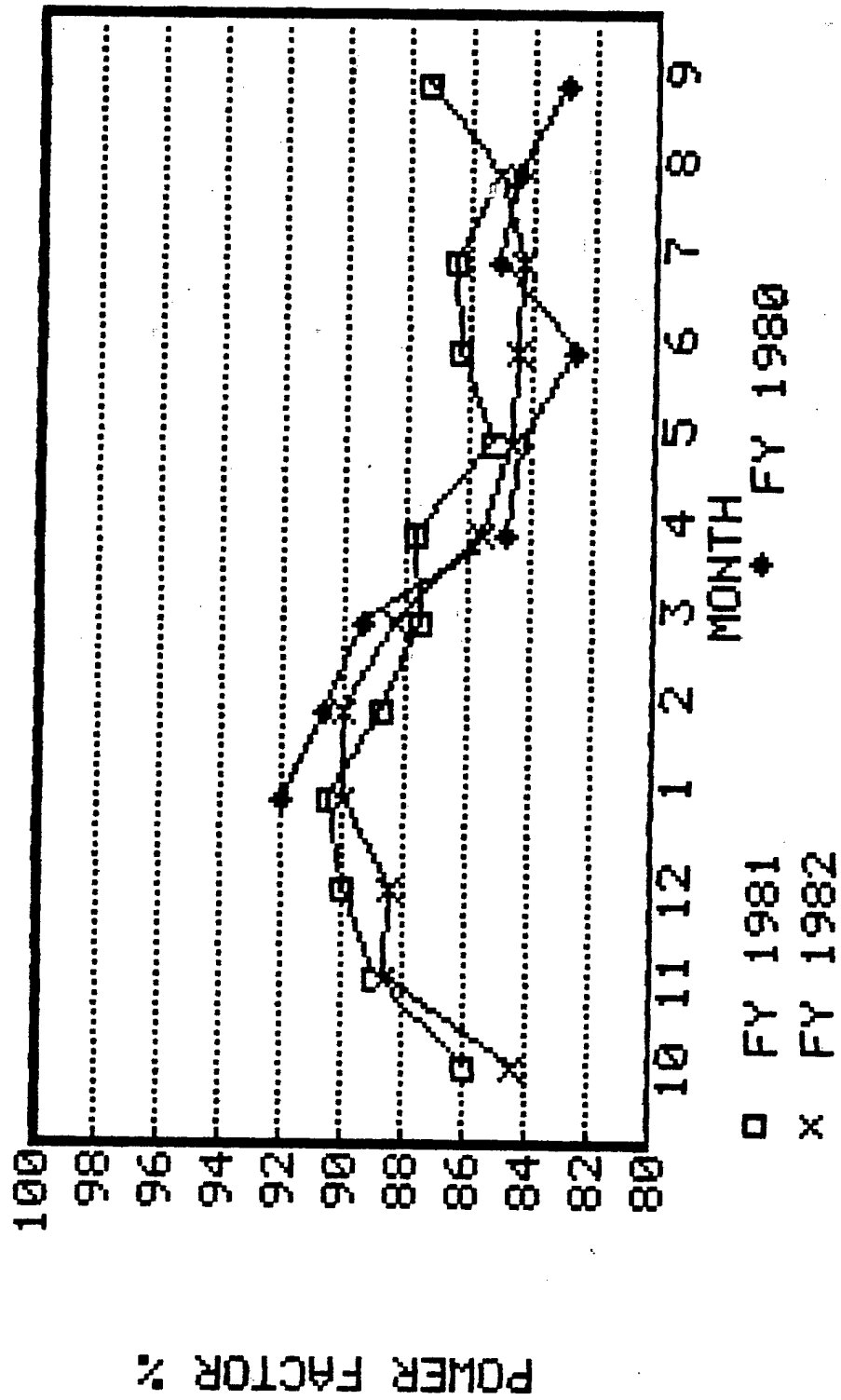

FIG. I-40

# MONTHLY LOAD FACTOR

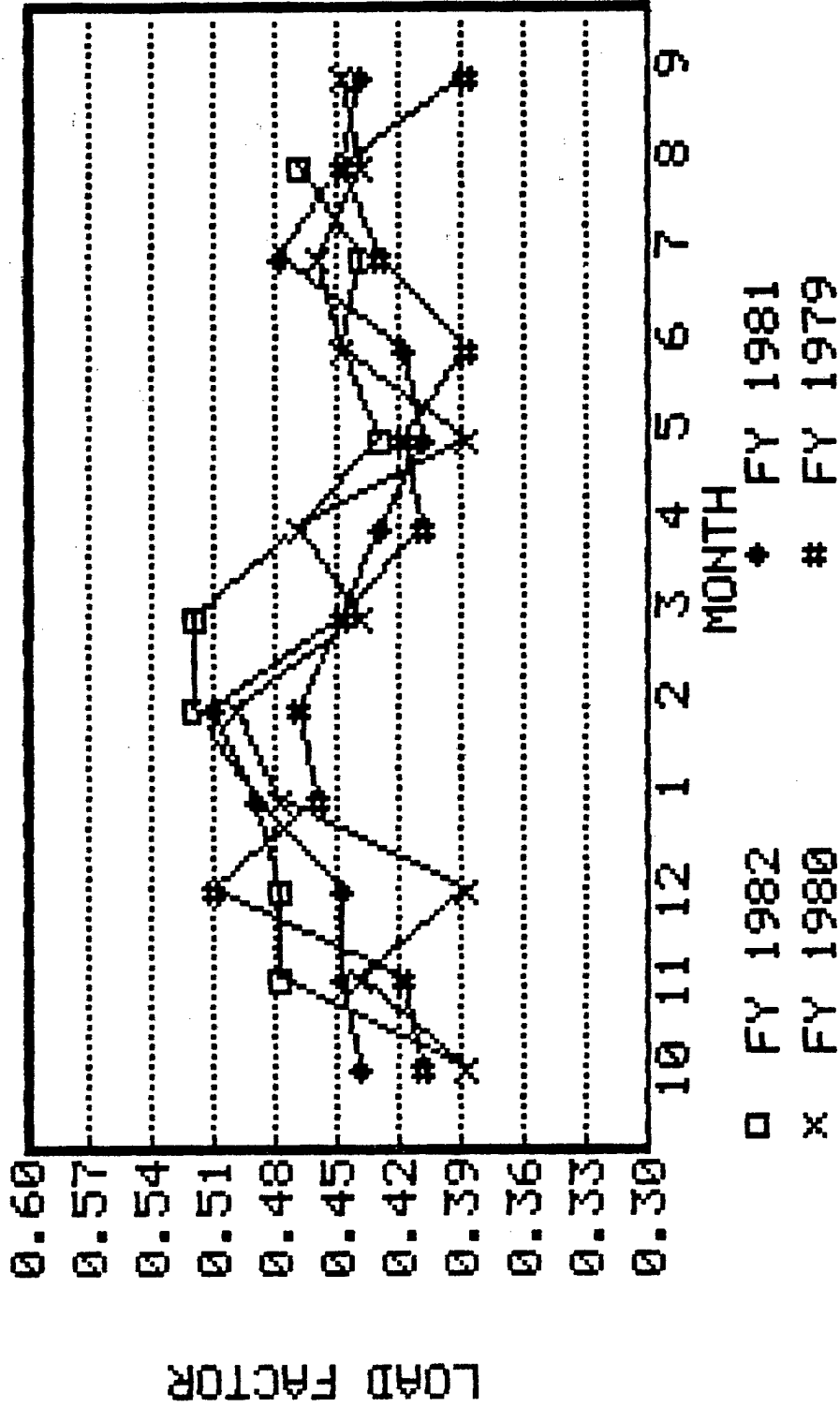

FIG. I-41

### 5.3 Natural Gas and Supplemental Boiler Fuel

- 5.3.1 Natural gas is presently supplied to the base by Arkansas and Louisiana Gas Co. (or ARKLA). The monthly consumption of this gas is represented in Figure I-42.
- 5.3.2 The cost of natural gas is, for all practical purposes, based on two charges: a flat rate of \$2.55 per MCF plus an additional monthly gas cost adjustment. The former is determined by ARKLA's rate schedule. The latter is based on the additional costs, per MCF, that ARKLA incurs when making purchases from natural gas producers. Natural gas costs are shown in Figures I-43 and I-44.
- 5.3.3 ARKLA adjusts each customers monthly cost with the following factors: a supercompressibility factor; a base pressure factor; and a BTU content factor. These adjustments convert MCF of gas to MMBTU's of energy. In effect, McaAAP's is charged on an MMBTU basis.
- 5.3.4 The general terms and conditions of ARKLA's rate schedule include an "Order of Curtailment." Under these conditions, ARKLA may curtail McaAAP's natural gas supply whenever it is necessary. At the time of curtailment, the dual fuel boilers in the nine production boiler plants are switched to #2 fuel oil until the natural gas curtailment is lifted. In FY 82, boiler fuel represented 0.45% of all source energy consumed by McaAAP, and 1% of the total energy cost. Higher levels of boiler fuel consumption occurred in the years FY 76 to FY 79 because of longer curtailment periods.
- 5.3.5 Changes in the mission and production levels of McAlester cause major differences in gas consumption. The nine production boiler plants accounted for 72% of all natural gas use, and 100% of all supplemental boiler fuel use.
- 5.3.6 It is expected that McaAAP will be supplied with natural gas produced from on-site gas wells at market prices. (Reference Section 6.2 of the Executive Summary.) When this occurs, current estimates from the Oklahoma Corporation Commission project a reduction in natural gas costs from a current \$4.51 per MCF to \$2.95 per MCF.
- 5.3.7 For the purpose of this study, natural gas costs are assumed to be the estimated market price of on-site gas. The contract currently being negotiated for on-site gas includes provisions for an uninterruptable gas supply. Thus natural gas curtailment periods will be

eliminated and the future consumption of boiler fuel is assumed to be zero.

GAS CONSUMPTION

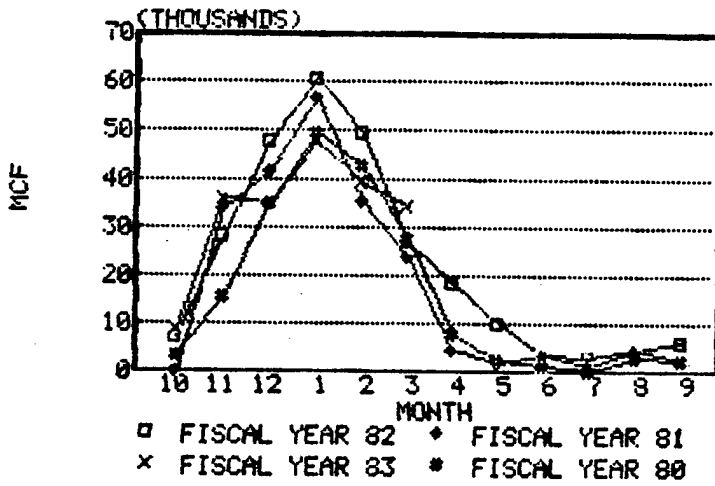

FIG. I-42

MONTHLY GAS COST

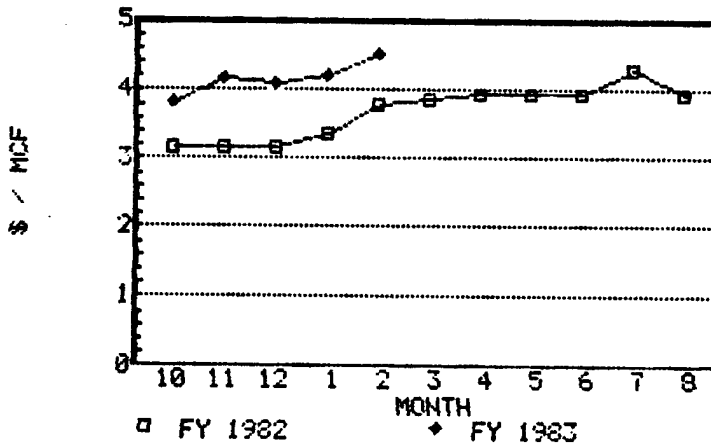

FIG. I-43

MONTHLY GAS COST ADJ

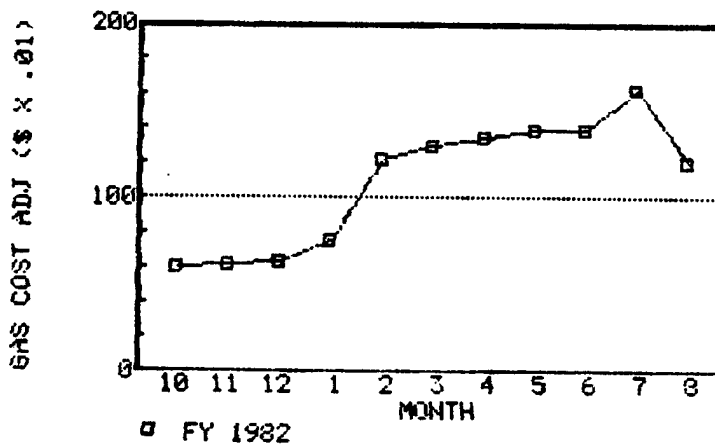

FIG. I-44

## 6. ENERGY CONSERVATION AT McAAP

### 6.1 Energy Reduction Goals

- 6.1.1 Energy reduction goals were eliminated by AARCOM for McAAP at the beginning of Fiscal Year 1982, because McAAP is a production facility, and as such, has a varying workload. The changes in production levels cannot be altered, therefore the energy usage comparisons from one year to the next would have to be adjusted on the basis of production. However, based on available information, it is not possible to accurately arrive at an energy consumption "per production unit" basis.
- 6.1.2 Estimating energy consumption on a unit basis is complicated at McAAP by several factors. One is the varying workloads that may be assigned to a given building. Each production job will require a different energy input, depending on the processes involved. Another factor is whether or not the entire building is being used or only part of it. Weather variations and energy conservation programs will also affect energy usage from one year to the next.
- 6.1.3 In the past, Executive Order 12003, dated 7/20/77, specified a 20% reduction in energy use in existing buildings on a square foot basis in 1985 as compared to 1975. McAlester has not been assigned this goal directly, but has been attempting to increase this reduction to 25%.
- 6.1.4 The Army Facilities Energy Plan also specifies a reduction in energy use of 20% over that of FY 75 and a 40% reduction by FY 2000.
- 6.1.5 Present ECIP funding through FY 85 is to reduce energy consumption by 12% throughout the Army or about 1.7% per year.
- 6.1.6 The DARCOM Supplement to the Army Energy Plan dictates a 2% reduction in energy use over the prior year's adjusted use, starting with FY 81. For FY 79 and FY 80, AARCOM requested a 5% reduction over the prior year's use.

### 6.2 Energy Related Issues - Summary

- 6.2.1 In reviewing the utility and energy analysis for McAAP, the following factors are summarized for review.

#### 6.2.2 On-Site Natural Gas Wells

When contractual arrangements are finalized between McAAP personnel and the private companies involved, McAAP's working portion of these wells will completely fulfill the base's natural gas requirements. Based on the projected well-head cost of \$2.95 per MCF, natural gas costs will be reduced by one-third and total energy costs by one-fifth. This will make energy conservation investments, based on ECIP criteria, more difficult to justify.

#### 6.2.3 Electrical Energy Costs

Energy investments are justified only to reduce the thermally generated energy which augments the hydro-electric energy. Obviously, it is uneconomical to reduce the consumption of hydro-electric energy, which is currently purchased at a price of \$0.0035 per KWH.

#### 6.2.4 Electrical Demand Costs

The monthly demand costs paid by McAAP are constant up to the 2688 KW limit, regardless of the metered KW demand. (See the discussion in the utility cost section.) As long as the maximum demand is kept at or below the contract demand level of 2688 KW, the monthly demand costs cannot be reduced. Further discussion can be found in Increment 'F'.

#### 6.2.5 Production Energy Use

A major energy use on base is related to production tasks and production support. This component of energy use is proportional to the production activity and not directly subject to conservation activities of the EEAP

#### 6.2.6 Facility Utilization

Production facilities are used as specific production tasks require. Intermittent and unpredictable operations make energy investments more difficult to justify. Information on production facility scheduling over a three year period was compiled to determine the average use for each building, so that the economic feasibility of energy projects could be examined on a building by building basis.

### 6.2.7 Safety Factors

Safety issues are paramount in production areas. The requirements for explosion-proof equipment and non-static materials make energy investments more costly.

### 6.2.8 Breakdown of Facility Energy Use

Electrical meters measure the total basewide electrical consumption. Sub-metering for typical building groups or individual buildings does not exist in all cases. Natural gas sub-metering is only available for each production boiler plant. Breakdown of energy use beyond these points are based on survey data, computer simulations and engineering calculations.

## 6.3 Energy Conservation Investment Program

### 6.3.1 Overview

To attain the energy reduction goals, the Energy Conservation Investment Program (ECIP) has been established to provide a major source of funding.

### 6.3.2 ECIP Analysis

All ECIP analyses are performed using a life cycle cost method.

### 6.3.3 Savings

1. All savings are based on a maximum economic project life of 15 years.
2. Annual energy savings are based on current utility rates, except for on-site natural gas, where an estimated price provided by McAAP personnel, of \$2.95 per MCF is used. This information provided to McAAP by Oklahoma Corporation Commission.
3. Discounted energy savings for McAAP are calculated using the uniform present worth factors provided in the ECIP guidance, for Region 6. These are based on DOE projected escalation rates. Reference Appendix B for UPW's.
4. Annual non-energy savings/costs are based on costs, charges, and/or labor rates effective on the date of analysis.

5. Discounted non-energy savings/costs are calculated using uniform present worth factors based on a 7% discount rate. Reference Appendix B.

#### 6.3.4 Project Cost Analysis

Two project costs are calculated. The first is an energy investment cost, per ECIP guidelines, used to calculate the savings to investment ratio. The second is a total cost representing the actual amount that will have to be requested from funding sources.

##### 6.3.4.1 Energy Investment Cost

Actual direct costs are adjusted to include the appropriate modifying factors. The following factors are used:

1. An overhead rate of 15%, unless otherwise noted.
2. A profit mark-up of 10%, unless otherwise noted.
3. A bond allowance of 1.25%, unless otherwise noted.
4. Project design costs based on 6% of total construction cost, unless otherwise noted.
5. Supervision and Administration Factor of 5% based on guidelines of AR 415-17.
6. All adjusted costs are multiplied by 90% to reflect the energy investment costs, per ECIP guidelines.

##### 6.3.4.2 Total Funding Requested

The total construction cost, including contractor mark-ups and design costs, are adjusted by the following factors:

1. Supervision and Administration Factor of 5%, based on guidelines of AR 415-17.
2. Contingency Factor of 10% based on guidelines of AR 415-17.

3. A Cost Growth due to Economic Factor of 6.97% based on the following indices found in the EIRS bulletin of May 12, 1982.

Beginning of Construction	Jan. 85	1477
Mid-point	July 86	1580
Completion	Oct. 87	1673

The escalation to mid-point of construction is calculated as  $1580/1477 = 1.0697$  or 6.97%. Reference Appendix B.

4. A Cost Growth due to Technological Factor of 10% is used, as required by the Scope of Work.
5. A cost data reliability factor based on the guidelines of AR 415-17. The following factors apply.

Low Technical Complexity	0.30%
High Technical Complexity	7.50%
Very High Technical Complexity	15.00%

#### 6.3.5 ECIP Qualification

To qualify for ECIP the following requirements must be met.

1. The project's ratio of discounted savings to energy investment cost (savings investment ratio) must be greater than one.
2. Each discrete project portion must have a savings investment ratio greater than one.
3. At least 75% of the total discounted dollar savings used to compute the SIR must result directly from energy savings.
4. The total project cost must be greater than \$200,000.00.
5. Under no circumstances is an economic life of more than 15 years to be assumed.

If a project has an SIR greater than one but does not meet the other requirements, it is classified as a non-ECIP project.

## 6.4 Summary of Energy Costs on Date of Analysis

### 6.4.1 Hydro-electric demand costs

\$1.95 per KW per month for 2688 KW contract demand, or \$5,241.60 monthly. This cost is expected to increase to \$2.95 per KW per month.

### 6.4.2 Thermal electric demand costs

\$1.787 per KW per month for 2688 KW contract demand, or \$4,803.46 per month. The two demand costs are paid to insure that McAAP will have up to 2688 KW of power whenever required. Refer to Increment 'F', 6.3.1, Demand Limiting Strategies.

### 6.4.3 Hydro-electric energy costs.

\$0.0035 per KWH for available hydro production during each billing period.

### 6.4.4 Thermal electric energy costs

This cost depends on what SWPA must pay to PSO when purchasing thermal energy to augment hydro-electric energy. Currently, this is averaging \$0.029 per KWH, including fuel cost adjustments.

### 6.4.5 Power Factor Penalty

The total of all demand and energy costs are increased by 1% for every 1% the average monthly power factor is below 95%.

### 6.4.6 Supplemental Electrical Energy

This is based on PSO's standard rate schedules. (See Appendix A.) These rates only apply when McAAP exceeds 2688 KW.

### 6.4.7 Natural Gas

Currently at \$4.51 per MMBTU. This is based on a flat rate of \$2.55 per MMBTU plus an additional gas cost adjustment factor of \$1.96 per MMBTU. This cost is projected to decrease to \$2.95 per MMBTU when natural gas from the on-site gas wells is made available.

## 7. ENERGY CONSERVATION MEASURES DEVELOPED - INCREMENTS A, B, & G

### 7.1 Summary of Energy and Cost Savings

The following table summarizes the effect that the energy conservation projects developed in Increments 'A', 'B' and 'G' would have on McAAP's energy consumption and utility costs. The data presented is based on the following:

- 7.1.1 Energy consumption is based on Fiscal Year 1982 data.
- 7.1.2 Except for natural gas, energy costs are based on the utility rates that were in effect on the date of analysis. The natural gas price is based on an estimated \$2.95 per MCF. It should be noted that an increase in this price will dramatically improve the SIR of many projects.
- 7.1.3 Energy and cost savings are based on the findings of the A/E. This data is explained in the corresponding sections of the Narrative Report.
- 7.1.4 Construction costs are estimates that exclude the 90% energy credit calculation per ECIP guidelines.
- 7.1.5 Savings to Investment Ratio is based on 15 year life cycle costs and 90% of the total construction costs, design costs, and supervision and administration costs.

### 7.2 Theoretical Energy and Cost Savings

Another table is provided which summarizes energy use and utility costs based on a theoretical condition of the ammunition production plants operating on a one shift per day basis, four days a week, 52 weeks a year. Under these conditions, the energy use of many production buildings will increase. In this case the projects proposed by the A/E in some increments would be expanded to include these buildings.

### 7.3 ECM's Investigated

Following this table is a list of all the remaining energy conservation measures that were investigated by the A/E. They are categorized as Facility Engineering Measures, or as measures that were analyzed but found to be not feasible. A detailed discussion of these measures is included in Increment 'F'.

#### 7.4 Analysis Methods

The evaluation of ECO's was based on calculations as correlated to computerized simulation of base facilities. The computer analysis, utilizing the TRACE program (Trane Company - La Crosse, WI), was the starting basis for ECO evaluation in that it provided an overall assessment of building energy use for each mechanical/electrical system. Additional analysis of high-pressure boiler systems was completed with an in-house program tailored to specific facility design.

The analysis of ECO's will follow format and methodology published with the scope of work. Several of these more commonly used measures have been computerized to facilitate analysis speed and accuracy.

The necessary supporting technical reference documents have been received and reviewed. These documents were used as necessary throughout the analysis. Conflicts in methodology between technical references were resolved by using document most recently published.

Appendix B provides general calculations guidelines and procedures common to various ECO's. Specific ECO's are evaluated in other parts of the Appendix.

#### 7.5 List of Buildings Studied for ECO's

##### 7.5.1 Infra-red Radiant Heating Systems

Building numbers: 3, 8, 9, 10, 14, 14A, 59, 430, 431

##### 7.5.2 Loading Dock Doors

Building numbers: 100, 104, 109, 126, 140, 142, 179

##### 7.5.3 Unoccupied Temperature Setback

Building number: 1

SUMMARY OF ENERGY CONSERVATION PROJECTS & SAVINGS

PROJECT	NAT. GAS SAVINGS MCF	ELECTR. SAVINGS KWH	SOURCE ENERGY SAVINGS MMBTU	UTILITY COST SAVINGS \$	ANNUAL O & M SAVINGS \$	PROJECT CONSTRUCTION COST \$	SIR \$
<b>1. Increment 'A'</b>							
A. Infra-red Heating	5,294	33,403	5,845	16,586	--	141,414	1.63
B. Dock Door Seals	2,919	--	3,009	8,611	--	93,743	1.28
C. Temperature Controls	947	--	976	2,794	--	10,271	3.80
D. Total Increment 'A'	9,160	33,403	9,830	27,991	--	245,428	1.59
<b>2. Increment 'B'</b>							
A. EMCS							
1. Temperature Control	24,309	--	25,062	71,711	--		
2. Optimum S/S	307	--	317	906	--		
3. Boiler Monitoring	--	--	--	--	57,657		
4. Equipment Monitoring	--	--	--	--	57,658		
5. Operating Costs	--	--	--	--	- 14,455		
6. Total EMCS	24,616	--	25,379	72,617	103,860	834,277	2.64
B. Steam Line Insulation and System Redesign	32,693	--	33,707	96,444	72,557	1,362,124	1.59
<b>3. Increment 'G'</b>							
A. Power Factor Correction							
	--	--	--	26,467	-3,000	85,533	2.78
4. Total for All Projects	66,469	33,403	68,916	223,519	173,417	2,441,829	1.97
FY 82 Energy & Cost Electric Based on Current \$ Gas Based on On-Site Gas							
	269,932	10,132,320	395,835	1,160,741			
Percent Reductions	24.5%	0.3%	17.35	19.2%			

FIG. I-45

CURRENT GAS PRICES

SUMMARY OF ENERGY CONSERVATION PROJECTS & SAVINGS

PROJECT	NAT. GAS SAVINGS MCF	SOURCE ELECTR. SAVINGS KWH	UTILITY ENERGY SAVINGS MMBTU	ANNUAL COST SAVINGS \$	PROJECT O & M SAVINGS \$	CONSTRUCTION COST \$	SIR \$
<b>1. Increment 'A'</b>							
A. Infra-red Heating	5,294	33,403	5,845	24,845	--	141,414	2.35
B. Dock Door Seals	2,919	--	3,009	13,165	--	93,743	1.96
C. Temperature Controls	947	--	976	4,271	--	10,271	5.81
D. Total Increment 'A'	9,160	33,403	9,830	42,281	--	245,428	2.40
<b>2. Increment 'B'</b>							
A. EMCS							
1. Temperature Control	24,309	--	25,062	109,634	--	--	--
2. Optimum S/S	307	--	317	1,385	--	--	--
3. Boiler Monitoring	--	--	--	--	57,657	--	--
4. Equipment Monitoring	--	--	--	--	57,658	--	--
5. Operating Costs	--	--	--	--	- 14,455	--	--
6. Total EMCS	24,616	--	25,379	111,019	103,860	834,277	3.29
B. Steam Line Insulation and System Redesign	32,693	--	33,707	147,445	72,557	1,362,124	2.11
<b>3. Increment 'G'</b>							
A. Power Factor Correction							
	--	--	--	26,467	-3,000	85,533	2.78
4. Total for All Projects	66,469	33,403	68,916	327,212	173,417	2,441,829	2.55
FY 82 Energy & Cost							
Electric Based on Current \$							
Gas Based on Current \$							
Percent Reductions							
	24.5%	0.3%	17.35	19.2%			

FIG. I-45A

ON-SITE GAS PRICES

**T H E O R E T I C A L E N E R G Y C O N S E R V A T I O N S A V I N G S**

PROJECT	NAT. GAS SAVINGS MCF	ELECTR. SAVINGS KWH	SOURCE ENERGY SAVINGS MMBTU	UTILITY COST SAVINGS \$	ANNUAL O & M SAVINGS \$	PROJECT CONSTRUCTION COST \$	SIR \$/\$
<b>1. Increment 'A'</b>							
A. Infra-red Heating	5,293	33,404	5,845	16,583	--	141,413	1.63
B. Dock Door Seals	12,191	--	12,569	35,963	--	216,782	2.32
C. Temperature Controls	947	--	976	2,794	--	10,271	3.80
D. Total Increment 'A'	18,431	33,404	19,390	55,340	--	368,466	2.09
<b>2. Increment 'B'</b>							
A. EMCS							
1. Temperature Control	18,100	--	18,661	53,395	--		
2. Optimum S/S	750	--	773	2,213	--		
3. Boiler Monitoring	--	--	--	--	86,486		
4. Equipment Monitoring	--	--	--	--	86,486		
5. Operating Costs	--	--	--	--	- 161,761		
6. Total EMCS	18,850	--	19,434	55,608	11,211	893,576	1.00
B. Steam Line Insulation and System Redesign	38,157	--	39,340	112,563	72,557	1,362,224	1.75
<b>3. Increment 'G'</b>							
A. Power Factor Correction	--	--	--	29,106	-3,000	85,533	3.09
4. Total for All Projects	75,438	33,404	78,164	252,617	80,768	2,709,799	1.53
Theoretical Energy & Cost Electric Based on Current \$ Gas Based on On-Site Gas							
Percent Reductions	24.3%	0.2%	16.7%	17.8%			

FACILITY ENGINEER ENERGY CONSERVATION MEASURES	ITEM	MAN-HOURS	LABOR COST	MATERIAL COST	ANNUAL SAVINGS	SIR	O P E R A T I O N & MAINTENANCE			
								NO COST	WILL INCREASE LIFE OF BOILERS	PREVENT WATER TUBE FOULING
01.	DEFINE PRODUCTION STEAM LINE START-UP									
02.	REVIEW WATER TREATMENT PROGRAM FOR BOILER PLANTS									
03.	LOWER DOMESTIC WATER TEMPERATURE									
04.	LIGHTING CONTROL-TURN LIGHTS OFF									
05.	UTILIZE DAYLIGHTING									
06.	REPAIR DUCT INSULATION									
07.	REPAIR DAMPER SEALS									
08.	REPAIR STEAM DISTRIBUTION LEAKS									
09.	REPAIR RADIATOR AND UNIT HEATER STEAM TRAPS									
10.	PERFORM LIGHTING FIXTURE MAINTENANCE									
11.	REPAIR GRAVITY VENTILATORS (PER 36-IN DIA UNIT)	4	56.00	100.00	65.00	6.5				
12.	INSPECT AND CALIBRATE CONTROLS (PER THERMOSTAT)	1	14.00	0.00	50.00	3.4				
13.	PERFORM FILTER MAINTENANCE (PER AHU, W/10-HF FAN)	0.5	7.00	20.00	50.00	1.8				
101.	REDUCE LIGHTING LEVELS:DE-LAMPING (PER 2000 SQFT)	1.5	21.00	0.00	22.00	11.4				
102.	INSTALL AUTOMATIC NIGHT SET-BACK THERMOSTATS (2000 SQFT)	1.5	21.00	130.00	50.00	4.2				
103.	REDUCE SUPPLY AIR QUANTITIES (PER AHU, W/ 7.5-HP FAN)	4	56.00	45.00	VARIES	2 TO 10				
104.	INSTALL TIMERS ON A/C EQUIPMENT TO LIMIT OPERATION	4	56.00	140.00	35.00	2.0				
105.	INSTALL THERMOSTATICALLY CONTROLLED RADIATOR VALVES	2	28.00	75.00	15.00	1.8				
106.	WEATHERSTRIPPING AND CAULKING TYPICAL DOOR OR WINDOW	1.5	21.00	25.00	10.00	1.4				
107.	INSTALL MOTION DETECTOR SWITCHES (PER CONFERENCE ROOM)	4	56.00	175.00	VARIES	1.3				
MAJOR DESIGN AND CONSTRUCTION COST										
101.	REPLACE TRANSFORMERS W/ EFFICIENT TRANSFORMERS	87.0	2200	22900	1000	2.4				
102.	REPLACE MOTORS W/ EFFICIENT MOTORS (BRKDN RPLCMT ONLY)	2	27.00	650.00	29.00	2.5				
103.	REPLACE FLUORESCENT BALLASTS W/ EFFICIENT BALLASTS	0.5	7.00	16.00	0.75	1.7				
104.	REPLACE FLUORESCENT LAMPS W/ EFFICIENT LAMPS	0.25	3.50	2.60	0.45	1.7				
105.	REPAIR STEAM LINE INSULATION (OVER 20 YEAR PERIOD)	8700	130800	206400	14800	1.6				
105.	REPLACE WALL A/C UNITS W/ A CENTRAL SYSTEM									

FIG. I-47

```

ENERGY CONSERVATION MEASURES FOUND NOT FEASIBLE
ITEM
COMMENTS
INSULATION HAS BEEN INSTALLED UNDER A SEPERATE E.C.I.P. PROJECT
HIGH INSTALLED COST, LOW FUEL COSTS, MARGINAL HEATING DEGREE DAYS
RECOMMEND USE OF EXISTING INDOOR SHADING DEVICES
COST EFFECTIVE METHOD NOT IDENTIFIED
TRAFFIC LEVELS NOT SUFFICIENT TO WARRANT INSTALLATION
RECOMMEND INSTALLATION OF DOCK DOORS, REFERENCE INCR. 'A'
NOT COST EFFECTIVE UNLESS INSTALLED WHEN ROOF MAINTENANCE IS PERFORMED
BUILDINGS TOO FAR APART, COOLING LOAD DENSITY NOT HIGH ENOUGH
LOW NATURAL GAS COSTS PERCLUDE USE
EX: 20000 CFM HX DISCNT SVNGS = $.26,000, INSTLD COST = $45,0000
INFRA-RED HEATERS RECOMMENDED OVER FANS, REFERENCE INCR. 'A'
INVESTMENT REQUIRED TO RETROFIT EXISTING SYSTEMS IS COST PROHIBITIVE
NOT APPLICABLE TO EXISTING SYSTEMS
EXISTING CFM RATES MEET MINIMUM STANDARDS
NOT APPLICABLE
HIGH CAPITAL COST, RECOMMENDED FOR MAJOR BUILDING REMODELLING
PROJECT CURRENTLY BEING IMPLEMENTED ON A REPLACEMENT BASIS
NOT APPLICABLE
BOILERS ADEQUATELY LOADED IN SUMMER, SAFETY CONSTRAINTS IN PRODUCTION AREAS
RELATIVELY LOW STACK TEMPERATURES, AND BOILER OPERATION IS ROTATED
CURRENT EFFICIENCIES ARE WITHIN CLOSE COMPLIANCE OF DESIGN SPECIFICATIONS
EXISTING CONTROLS ARE CONSIDERED ADEQUATE
NON-CONTINUOUS BLOWDOWN, BOILER ROTATION, INSTALLATION OF NEW CONDENSATE RETURN
LINES REQUIRED, RELATIVELY LOW STEAM CONDENSATE TEMPERATURES
EXISTING PRESSURES REQUIRED TO DELIVER STEAM THROUGH LENGTHY DISTRIBUTION SYSTEM
HIGH INITIAL COST TO INSTALL CONDENSATE RETURN LINES, CONDENSATE CONTAMINATED

```

FIG. I-48

## 8. OTHER ENERGY CONSERVATION ITEMS

### 8.1 Increment 'C'

#### 8.1.1 Scope

Increment C, the evaluation of renewable energy sources, is not part of this contract. However, a brief review of two low temperature solar systems is provided.

#### 8.1.2 Conclusions

It is not economically feasible to implement solar systems at McAAP. A solar system could displace 65% to 70% of DHW and hot water process load energy requirements. However, the intensive capital expenditure, the expected availability of natural gas at well head prices, and the lack of private-sector tax incentives make solar options unattractive.

### 8.2 Increment 'D'

#### 8.2.1 Scope

An interim analysis of a cogenerating power plant has been included. The analysis is based on the simulation of a natural gas reciprocating engine that would utilize on-site gas at well head costs.

#### 8.2.2 Conclusions

8.2.2.1 Based on the existing operation of the plant, a cogeneration scheme is not recommended. The following items apply:

- 1) Should a cogeneration plant be constructed, SWPA has stated that a new contract would be negotiated which would reduce the contract demand by an amount equal to the KW output of the generating equipment. This would reduce the quantity of inexpensive hydro-electric energy that McAAP could purchase. Should a generator fail and the reduced contract demand be exceeded, McAAP would also be required to pay higher demand and energy charges directly to PSO.
- 2) An optimum balance between electrical and thermal loads does not exist on a continuous basis, due to the intermittent operation of the plant.

8.2.2.2 A cogeneration scheme is recommended under the following conditions:

- 1) If the plant were to operate on a continuous basis. This would improve the thermal load balance and would increase the installation's peak KW demand beyond the limitations of the current SWPA contract demand or 2688 KW.
- 2) If the Bomb and Mine 'A' Plant should be utilized. This would also increase the peak KW demand beyond 2688 KW.

### 8.3 Increment 'F'

#### 8.3.1 Energy Conservation Activities to Date

##### 8.3.1.1 Modification Projects

Since 1975, one ECIP project, which was to to insulate 19 buildings, has been completed. The study was reviewed under this EEAP contract.

There are no ongoing or completed EMCS, solar, or solid waste fuel projects.

##### 8.3.1.2 F.E. Activities

The F.E. office, with the Energy Coordinator, has been the focal point for McAAP energy conservation activities. These activities fall into several areas:

###### 1) Installation Energy Plan (IEP)

Issued annually, this document "describes policies, objectives, priorities and procedures" for an installation program. The IEP is a useful document to establish a program framework and goals for energy management for each year.

We recommend that the conclusions and recommendations reached under this EEAP be factored into the IEP by the Energy Coordinator.

## 2) Energy Advisory Group (EAG)

The EAG meets on a monthly basis to discuss problem areas related to energy conservation and to generate ideas on conserving energy.

## 3) Technical Evaluation

F.E. personnel evaluate energy conservation measures on an ongoing basis. As examples, two mechanical projects were the analysis of boiler economizers (not recommended) and the development of a steam line insulation replacement program (funding applied for). One electrical project has been the delamping in several administration buildings.

### 8.3.1.3 Operating Practices

A series of Standing Energy Conservation Practices has been implemented. Our observations indicate that these practices were typically adhered to.

## 8.4 Master Plan

No McAAP master planning documents are currently in effect.

## 9. ENERGY PLAN

### 9.1 Near-Term Actions

9.1.1 The F.E. should implement Energy Conservation Action Orders to minimize energy waste and to benefit from low-cost modification measures. These measures should be undertaken as soon as practical in keeping with other F.E. responsibilities. Of particular importance are measures which involve heating system improvements, because heating costs account for the majority of energy costs. Prioritized recommendation of these projects are discussed in Increment 'F'.

9.1.2 Operating practices currently in place that are aimed at energy conservation should be continued. Policies discussed at the end of this chapter should be reviewed and incorporated in operating practice to the greatest extent possible.

## 9.2 On-Site Gas Supply

- 9.2.1 The use of on-site gas from the leased well sites is an important issue to be pursued. The cost savings associated with use of this source is significant. Natural gas costs account for more than one half of the total base energy expenditures and a reduction of 30% or more of the current natural gas costs is anticipated using on-site gas. Thus, overall base energy costs would drop approximately 18%.
- 9.2.2 McAAP personnel are currently negotiating the details of on-site gas service. We have factored in results of these discussions in this analysis.
- 9.2.3 Should this on-site gas not become available to McAAP, the A/E recommends that the FE re-evaluate the ECM's for potential feasibility.

## 9.3 Long-Term Programs

### 9.3.1 ECIP and Non-ECIP Projects

These measures should be implemented to the maximum extent possible.

### 9.3.2 Facility Construction

The concepts and ECMs discussed in this report should be considered in future construction and renovation.

### 9.2.3 Analysis Updates

The F.E. should review the conclusions of this report on a periodic basis to factor in any changes that would impact the analysis.

### 9.3.4 Master Planning

Results of this EEAP should be factored into upcoming master planning efforts.

## 9.4 Policy Issues

The F.E., working with other groups on the base, can create and maintain policies that encourage energy conservation.

#### 9.4.1 Installation Energy Plan

This document should be expanded, to become a more comprehensive document. The F.E. and Energy Coordinator should use the IEP to establish concrete objectives and schedules of tasks, to be completed over a year's time. Information presented under the EEAP should be factored into the IEP.

#### 9.4.2 Human Issues

The energy awareness program at McAAP is an important link to promote energy conservation. McAAP personnel have been involved in controlling several items, which relate to energy management (light switches, thermostats, AC units, etc.). We recommend that this level of involvement be continued and expanded with additional education, concerning the opportunities for natural daylighting, use of indoor shading devices, light fixture maintenance, and other energy saving ideas to make energy improvements.

Energy conservation improvements, accomplished by occupant cooperation, are the most cost effective and should not be overlooked. We noted that occupant cooperation to date has been good, however, additional opportunities should be pursued.

#### 9.4.3 Facility Scheduling and Utilization Planning

Scheduling of production facilities is an important factor in relation to building energy use. McAAP currently attempts to use a minimum number of production facilities to meet the varying production orders and schedules. We agree that the present facility scheduling method is appropriate.

The A/E has reviewed with McAAP personnel the possibility of developing a core group of buildings that could meet a diversity of production orders. This would allow a limited number of buildings to be used on a continuous basis while other buildings would be disconnected from utility services. Under this condition, energy efficiency would be maximized and additional investments could be justified for energy-efficient equipment that would be constantly used. However, the costs associated with redesigning the production assembly lines to meet a diversity of orders are extremely high and outweigh the potential annual energy savings.

We recommend, therefore that McAAP production personnel continue their present practice of matching production tasks to specific buildings.

#### 9.4.4 Lay-Away of Unused Buildings

Several buildings have been laid away, their use not being required to meet base mission. All utility service to these buildings has been curtailed. The opportunity to lay away additional buildings was discussed with McAAP personnel. They concluded that all currently active buildings are required to meet mission requirements. We concur with their approach and recommend that the F.E. factor this issue in with future plans.

McAAP has established a policy of using the minimum number of active buildings to meet production orders. The remaining buildings are inactive, using reduced amounts of energy. These temporarily inactive buildings have temperatures set back and electrical systems turned off within the building. Electrical service to the building is still required for the operation of condensate pumps, fans, and controls to prevent freezing.

The energy saving benefits of fully laying a building away should not be overlooked.

#### 9.4.5 Mobilization

The F.E. needs to consider energy use in relation to base mobilization. With increased scheduled use of production buildings, the energy consumption will also increase for buildings, boiler plants, vehicles, and railroad equipment.

#### 9.4.6 Plant Expansion

This submittal identifies several issues to be considered with facility modifications and new constructions. They are discussed in the Facility Engineer's Master Plan, Increment 'F'.

#### 9.4.7 Transportation

Energy use related to vehicles and transportation is a significant portion of total base energy use and cost (approximately 26% of total cost). These issues were previously discussed in subsection 4 of this Executive Summary.