

DRAFT SF 298

1. Report Date (dd-mm-yy)	2. Report Type	3. Dates covered (from... to)			
4. Title & subtitle Verification of the Boundary Element Modeling Technique for Cathodic Protection of Large Ship Structures Tri-Service Committee on Corrosion Proceedings		5a. Contract or Grant #			
		5b. Program Element #			
6. Author(s) Harvey P. Hack Robert M. Janeczko		5c. Project #			
		5d. Task #			
		5e. Work Unit #			
7. Performing Organization Name & Address			8. Performing Organization Report #		
9. Sponsoring/Monitoring Agency Name & Address Tri-Service Committee on Corrosion USAF WRIGHT-PATTERSON Air Force Base, Ohio 45433			10. Monitor Acronym		
			11. Monitor Report #		
12. Distribution/Availability Statement Approved for Public Release Distribution Unlimited					
13. Supplementary Notes					
14. Abstract					
DTIC QUALITY INSPECTED 2					
15. Subject Terms Tri-Service Conference on Corrosion					
Security Classification of			19. Limitation of Abstract	20. # of Pages	21. Responsible Person (Name and Telephone #)
16. Report	17. Abstract	18. This Page			

000955

**TRI-SERVICE
CONFERENCE
ON CORROSION**



21-23 JUNE 1994

**SHERATON PLAZA HOTEL
ORLANDO, FLORIDA**

PROCEEDINGS

PROPERTY OF:

AMPTIAC LIBRARY

19971028 050

Verification of the Boundary Element Modeling Technique for Cathodic Protection of Large Ship Structures

by Harvey P. Hack¹ and Robert M. Janeczko
Carderock Division, N. S. W. C., Annapolis, MD 21402-5067

ABSTRACT

Boundary Element computer modeling is gaining acceptance as a tool for predicting the distribution of cathodic protection potentials on a variety of large immersed structures. This technique should be valuable for placement of cathodic protection anodes and reference cells on ship hulls. Much has been published on this technique, including experimental verification on a laboratory scale. However, there has been little published information on experimental verification of the model predictions on large structures, especially for ships.

A 42-foot (14-m) barge was outfitted with a steel "rudder", copper-based alloy "propeller", zinc sacrificial anodes, and an array of reference cells to measure the distribution of potential over the surface of the hull and appendages. The barge was exposed in natural seawater for four months. A computer model was developed to predict the distribution of protection, using a boundary element analysis program (BEASY) and long-term, potentiostatic polarization curves as boundary conditions. The model predictions are compared to the measured potential distributions.

Polarization curves are presented which give good agreement between model predictions and the actual measurements on the uncoated steel barge hull under low flow conditions. More information on polarization behavior for surfaces under flowing conditions is needed for accurate predictions to be made over a full range of ship operating conditions.

ADMINISTRATIVE INFORMATION

This project was supported by the Carderock Division, Naval Surface Warfare Center Ship and Submarine Materials Block Program under the administration of Code 0115. The program manager is Mr.

Ivan Caplan. The work was conducted in the Marine Corrosion Branch, Code 2813, under the direction of Mr. Robert Ferrara. Outfitting and testing of the barge were conducted by the staff of the LaQue Center for Corrosion Technology under the direction of Mr. Dennis Melton. Help with computer programming difficulties was given by Jon Trevelyan of Computational Mechanics, Inc.

INTRODUCTION

Submerged steel structures, such as platforms and ships, usually require cathodic protection to minimize corrosion damage in seawater. This protection is provided by impressed current or sacrificial anodes located at discrete points on the structure. The level of protection is greatest near the anodes and falls off at large distances[1]. The non-uniformity of protection can lead to overdesign of the protection system. This is because the overall level of protection must be increased until the point with the least protection on the structure is receiving adequate protection. This overdesign can lead to wasted current or anode material, and can also lead to paint blistering or hydrogen embrittlement in areas near the anodes. Cathodic protection system designers therefore strive for uniformity of protection on the structure.

Uniformity of protection was, until recently, arrived at in a cathodic protection system design primarily by the use of rules-of-thumb and empirical experience. More recently, construction of physical scale models has been used with some success to optimize placement of anodes[2]. In many cases the use of physical scale modeling will produce results of sufficient accuracy for optimizing anode placement. There is some theoretical basis for a belief that there are inherent inaccuracies in this type of modeling for large structures in seawater, however[3]. In addition, effects of flow on moving structures are difficult to reproduce in scale model tests. For these reasons, as well as for reasons of cost of model construction, the use of computers to predict uniformity of protection is emerging as a viable alternative. Although computer modeling accuracy has been verified in small scale laboratory situations[4-5], there is to date little published evidence of verification of this technique on large structures.

Boundary element computer analysis is similar to finite element analysis in that the Laplace Equation is solved within the structure of interest after first defining conditions at the edge (boundary).[6] The structure of concern is divided into small elements, or discretized, and a series of simultaneous equations is obtained from the Laplace

Equation, one for each element.[7] The boundary element method requires that only the edges of the structure be modeled.[5]

In corrosion, the boundary conditions are the relationships between current and potential (called polarization behavior) for the materials and environment. Polarization behavior may not be single-valued or monotonic, requiring special consideration in programming.[8] This area of work is so new that only two companies have boundary element programs that can handle corrosion boundary conditions, and one of these programs has other limitations.[9] The other program, called Boundary Element Analysis System (BEASY) was used for this study.

The intent of this paper is to illustrate that computer modeling can accurately predict the distribution of cathodic protection on large structures resembling ship hulls in seawater. The polarization curves used to obtain the best agreement between the computer model and measurements on a large structure are also presented.

EXPERIMENTAL PROCEDURE

BARGE TESTS

Accuracy of computer modeling for ship hulls was investigated by using an 18 by 42-foot (6 by 14-m) steel barge to compare with the computer model. The barge was exposed without coatings for 4 months.

The barge was first hauled and sand blasted. It was then fitted with sacrificial anodes as follows: a group of six anodes at the stern midline, a group of eight anodes at the center midline with a group of four additional anodes on each end of the central grouping, and two groups of six anodes each at the outer edges on both sides. The anode groups were electrically isolated from the barge and externally connected to allow measurement of the protection current each group provided. A copper-nickel plate, roughly 32 by 36-inches (0.8 by 0.9-m) was suspended 0.9-feet (0.3-m) below the keel at the aft portion of the barge and oriented athwartships. This plate was designed to simulate a copper-alloy propeller and the plate-to-hull area was set to be representative of a real ship. A second plate, 37 by 38.5-inches (1.0 by 1.0-m) square made of steel, was suspended with its leading edge even with the stern, 3-feet (1-m) behind the first, and with its top edge parallel to the stern and at a height even with the keel. The area and orientation of this plate were set to simulate the rudder of a real ship. Both plates were wired back to the hull so that protection current could be measured. Finally, the barge was outfitted with an array of 34

silver/silver-chloride reference cells to measure the uniformity of protection. The locations of the anodes and reference cells are shown in figure 1.

After outfitting, the barge was placed in the water on the Cape Fear River in Wilmington, NC, with the port and starboard anode groups disconnected. This is brackish water with a conductivity of 145- μ mho/cm (0.81 ppt chloride). The barge was then towed to the test site in Banks Channel near Wrightsville Beach, NC. This location has full strength seawater with a conductivity of 50-mmho/cm (34.99 ppt chloride). The barge was moored at a location where the mean depth was roughly 11-feet (3.5-m). A series of current and potential measurements were then taken daily except for weekends until the total exposure period elapsed. Initially the anode groups at the edges of the barge were not connected, but it was determined that the barge required the additional anodes to get adequate protection, and so these anode groups were connected after eight days. A total exposure period of 4 months was chosen because earlier tests at this location had shown that stability of protection current was reached in that time[10]. At the conclusion of the test, all but the aft set of zincs were disconnected to get a greater potential gradient along the barge length. Measurements were taken after the protection system had been allowed to stabilize for 7 days. The barge was then towed back to the shipyard where measurements were taken in the lower conductivity water for an additional two days.

Besides monitoring currents from each bank of zincs, currents to the rudder and prop plates, and potentials of the reference cells, weight loss data was taken for each zinc to compare to integrated currents. This gave a check on the current measurement procedure and allowed for determination of zinc efficiencies.

COMPUTER MODEL

The exact barge geometry was modeled using the Boundary Element Analysis System (BEASY). This program is designed for corrosion problems and can handle time-dependent analysis[11], although that feature was not used in this study. The element structure used for the barge is shown in figure 2. The model was symmetric about the centerline and waterline, and non-conducting surfaces were placed at the mud line and at a distance of 330-feet (100-m) around the barge. 330-feet was chosen as it was expected that the potential gradients would be minimal at that distance. These surfaces were

necessary since the program required that the model be totally enclosed.

The zinc surfaces were initially assigned the polarization conditions shown in figure 3, the steel surfaces were initially assigned the conditions shown in figure 4, and the copper-nickel surfaces assigned the conditions in figure 5. These polarization curves were obtained from long-term potentiostatic polarization tests conducted in a previous project[10].

RESULTS AND DISCUSSION

BARGE TEST

Figure 6 shows the current, in Amperes, for each of the cathode surfaces. As expected, the current mostly went to the hull. Currents to all cathode surfaces initially began to fall, but jumped upwards after eight days when the two edge anode groups were connected. Current continued to fall throughout the exposure, probably due to the buildup of calcareous deposits and fouling. Another drop in current was experienced near the end of the exposure when all of the anode groups except one were disconnected. Total current at the conclusion of the exposure was roughly one third of the maximum current experienced after all anode groups were first connected. Figure 7 shows the output of each of the anode groups during the same time period. Current output was zero from the two edge groups until they were connected at day eight, and was the highest thereafter, probably because each group was so far from any other group. Near the end of the exposure when all other anode groups were disconnected, current from the aft group increased to try to make up for the difference.

Weight losses of each of the anodes are given in table 1. These values are summed for each group and compared to the integrated current for that group to calculate an electrochemical efficiency for each anode group and for all anodes on each barge. Efficiencies for each group ranged from 65 to 114 percent, indicating that the current measurement or integration technique was not sufficiently accurate. This is probably due to sampling times for current data of 1-3 days being too high. The average efficiencies for the anodes were 86%, which is low for zinc anodes. Initial high currents occurred for several hours before the first readings were taken, and currents could not be read during the two towing operations for each exposure. Both of these would lead to lower measured efficiencies than were actually experienced by the anode material.

COMPUTER MODEL

It was desired to determine the sensitivity of the computer solutions to changes in the input polarization curve shape in order to see how accurately polarization behavior must be determined in order to get an accurate solution. To this end, a number of variations in polarization curve shape were tried during the modeling effort for the uncoated barge. These included changing current magnitudes for the anodic and cathodic materials individually by multiplying the currents for all points for a given material by the same factor, and changing currents for individual points on the steel cathode in order to change the magnitude and slope of the curve in the 900-1000 mV range.

The shape and magnitude of the polarization curves used in the analysis had little effect on which area of the structure was predicted to receive the most or the least cathodic protection. Curve shape and magnitude outside of the range where the predicted potentials will lie also had no effect on the results of the analysis. Cathodic curves affected the predicted currents more than predicted potentials. The opposite was true for the anodic curves, where the predicted potentials were affected more than the predicted currents. Finally, it was easier to predict potentials accurately than to predict currents accurately.

COMPUTER PREDICTIONS VERSUS ACTUAL MEASUREMENTS

Protection Potentials

Use of the original polarization curves for uncoated, unfouled steel did not result in good agreement between the computer prediction and the measured potentials for the uncoated barge. The best agreement was obtained if the computer model was run under the assumption that 50% of the cathode surfaces were electrochemically blocked by fouling. This is consistent with the amount of hard fouling observed visually, and was accomplished by reducing the current densities of the cathode surfaces by 50% in the polarization curves used as boundary conditions. The result of this assumption was an agreement between measured and predicted potentials at the various reference cell locations which was within 20 mV except for three locations which were within 60mV. These three locations, at cells 6, 11, and 23, were all predicted to have more protection than actually measured. Since these cells were all at the waterline, this effect could be due to wave action wetting more hull surface than was modeled. This is excellent agreement considering the number of reference cells and complexity of the barge structure. The measured and predicted

potentials are plotted together in figure 8. The reference cells in this figure are in no particular order.

Currents

Table 2 lists the measured and the predicted currents for the barge hull, rudder plate, propeller plate, and currents from individual zinc groupings. The predicted currents were always a factor of 1.4 to 1.5 higher than those measured, and the relative amount of current from or to each area is the same for the predictions and the measurements. This shows that current distributions are easier to predict than absolute values of current. The factor of 1.4-1.5 is reasonable, and is in the right direction for a conservative design for a cathodic protection system.

CONCLUSIONS

Based on the BEASY computer model predictions and actual measurements on a 42-foot (14-m) barge simulating a steel ship, the following conclusions can be drawn:

1. Computer modeling accurately predicts potential distributions and currents for uncoated barges when the polarization curves are adjusted for fouling under low flow conditions.
2. It is easier for a computer model to accurately predict potentials than currents.
3. If inaccurate polarization data is used in the computer model, resulting in disagreement between predicted and actual magnitudes of potentials and currents, the areas of the most and the least protection are still predicted accurately.

REFERENCES

1. L. L. Shreir, Ed., Corrosion - Volume 2 - Corrosion Control, Chapter 11, Newnes-Butterworths, Boston, MA, ©1976.
2. D. J. Tighe-Ford, J. N. McGrath, and L. Hodgkiss, "Design Improvements for a Ship's Impressed Current Cathodic Protection System Using Dimension and Conductivity Scaling (DACS)," Corrosion Prevention and Control, October 1985.
3. H. P. Hack, "Scale Modeling for Corrosion Studies," Corrosion, Vol. 45, No. 7, July 1989.
4. P. Doig and P. E. J. Flewitt, "A Finite Difference Numerical Analysis of Galvanic Corrosion for Semi-Infinite Linear Coplanar Electrodes," Journal of the Electrochemical Society, December 1979, pp. 2057-2063.
5. J. W. Fu and J. S. K. Chow, "Cathodic Protection Designs Using an Integral Equation Numerical Method," Materials Performance, Vol. 21, No. 10, October 1982.
6. C. A. Brebbia, Ed., The Boundary Element Method for Engineers Computational Mechanics, Woburn, MA, 1980.
7. M. A. Warne, "Applications of Numerical Analysis Techniques," Proceedings of the Conference on Cathodic Protection Theory and Practice - The Present Status, Coventry, U. K., April 1982.
8. R. G. Kasper, "Theoretical and Experimental Comparisons of Nearfield Electrogalvanic Fields Due to Nonlinear Polarization Layers," NUSC Technical Report 7299, February 1985.
9. J. R. Scully and H. P. Hack, "Prediction of Tube-Tubesheet Galvanic Corrosion Using Long Term Electrochemical Polarization Data," in Galvanic Corrosion, H. Hack, Ed., STP 978, ASTM, 1988.
10. H. P. Hack and J. R. Scully, "Galvanic Corrosion Prediction Using Long and Short Term Polarization Curves," Corrosion, 42, No. 2, February 1986.
11. R. A. Adey and S. M. Niku, "Boundary Element Simulation of Galvanic Corrosion - the Story of a Major Success for Boundary Elements," Boundary Elements X, Vol. 2: Heat Transfer, Fluid Flow and Electrical Applications, C. A. Brebbia, Ed., Computational Mechanics Publications, Ashurst, UK, 1988.

Table 1 - Anode Weight Losses for the Barge

ANODE NO	ORIG WEIGHT, g	FINAL WEIGHT, g	WEIGHT LOSS, g	GROUP WEIGHT LOSS, g	THEORETICAL WEIGHT LOSS FROM CURRENTS, g (efficiency)
1	4996.8	3794.6	1202.2		STERN
2	4768.0	3874.1	893.9		
3	4823.1	3862.0	961.1		
4	4813.0	3921.1	891.9		
5	4870.3	3946.4	923.9		
6	4801.2	3631.4	1169.8	6042.8	
7	4862.2	3592.4	1269.8	added	ENDS added to anodes 19-22
8	4932.1	3981.1	951.0	to	
9	4724.4	3830.6	893.8	anode.s	
10	4780.5	3859.8	920.7	19-22	
11	4857.2	3991.9	865.3		MIDDLE
12	4954.3	3962.0	992.3		
13	4863.7	3650.3	1213.4		
14	4929.8	4019.7	910.1		
15	4791.1	3859.9	931.2		
16	4905.3	3965.4	939.9		
17	4773.9	3889.2	884.7		
18	4809.3	3651.6	1157.7	7894.6	
19	4850.2	4022.7	827.5		ENDS
20	4844.2	4144.4	699.8		
21	4758.4	3939.8	818.6		
22	4983.6	3957.4	1026.2	7407.4	
23	4462.2	3710.3	751.9		STARBOARD
24	4640.9	3977.3	663.6		
25	5000.8	4236.7	764.1		
26	5047.0	4242.7	804.3		
27	4978.9	4153.4	825.5		
28	4786.0	4023.2	762.8	4572.2	
29	4842.0	4135.3	706.7		PORT
30	4655.2	3926.3	728.9		
31	4875.2	3692.2	1183.0		
32	4666.1	3791.3	874.8		
33	4766.1	3885.1	881.0		
34	4914.2	4066.2	848.0	5222.4	
TOTAL	164327.2	133187.8	31139.4	31139.4	26819.8 (86%)

Table 2 - Currents for Barge, Amperes

COMPONENT	MEASURED	PREDICTED	DIFFERENCE FACTOR
Hull	4.20	5.79	1.38
Propeller Plate	0.08	0.11	1.38
Rudder Plate	0.07	0.10	1.43
Outboard Zincs	-0.92	-1.26	1.37
Aft Zincs	-0.74	-1.12	1.51
End Midships Zincs	-0.96	-1.43	1.49
Center Midships Zincs	-0.81	-1.24	1.53

Figure 1 - Anode and Reference Cell Locations on Test Barge

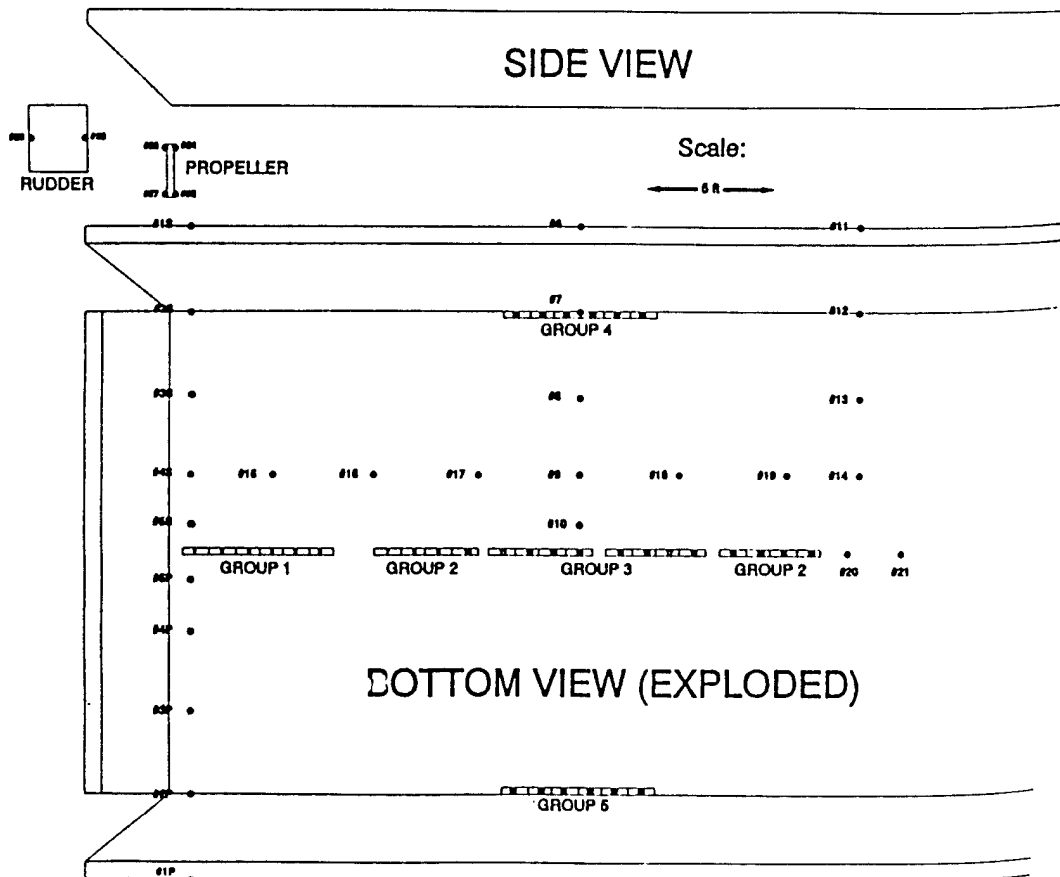

Figure 2 - Boundary Element Grid

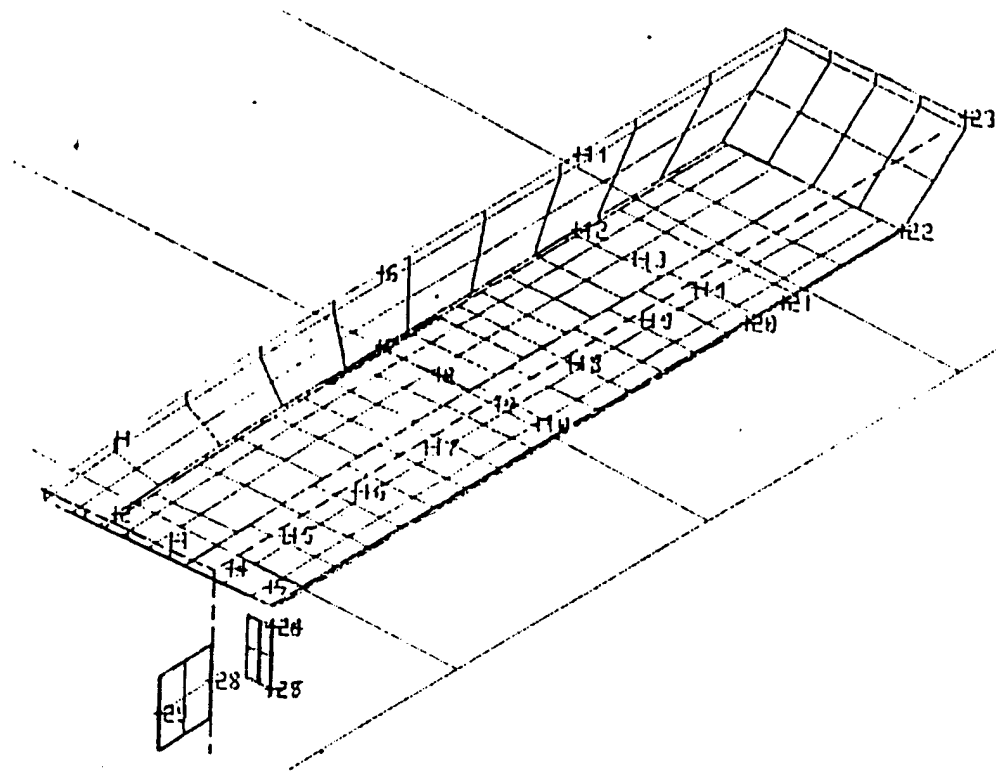
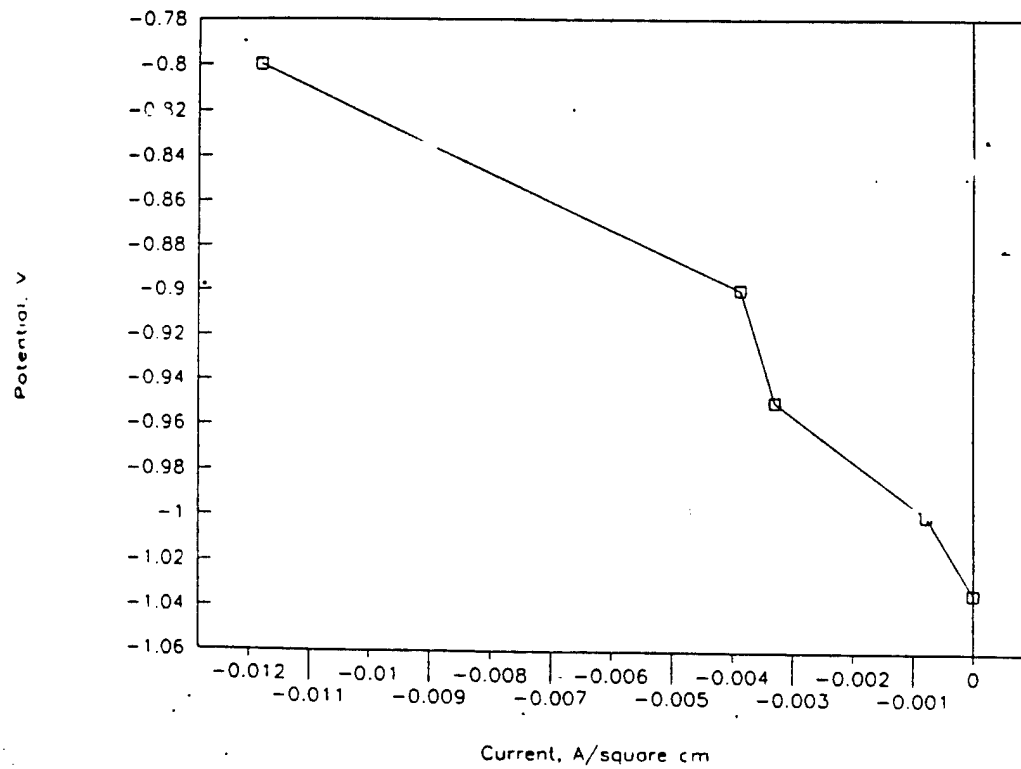

Figure 3 - Zinc Polarization Data



//

Figure 4 - Steel Polarization Data

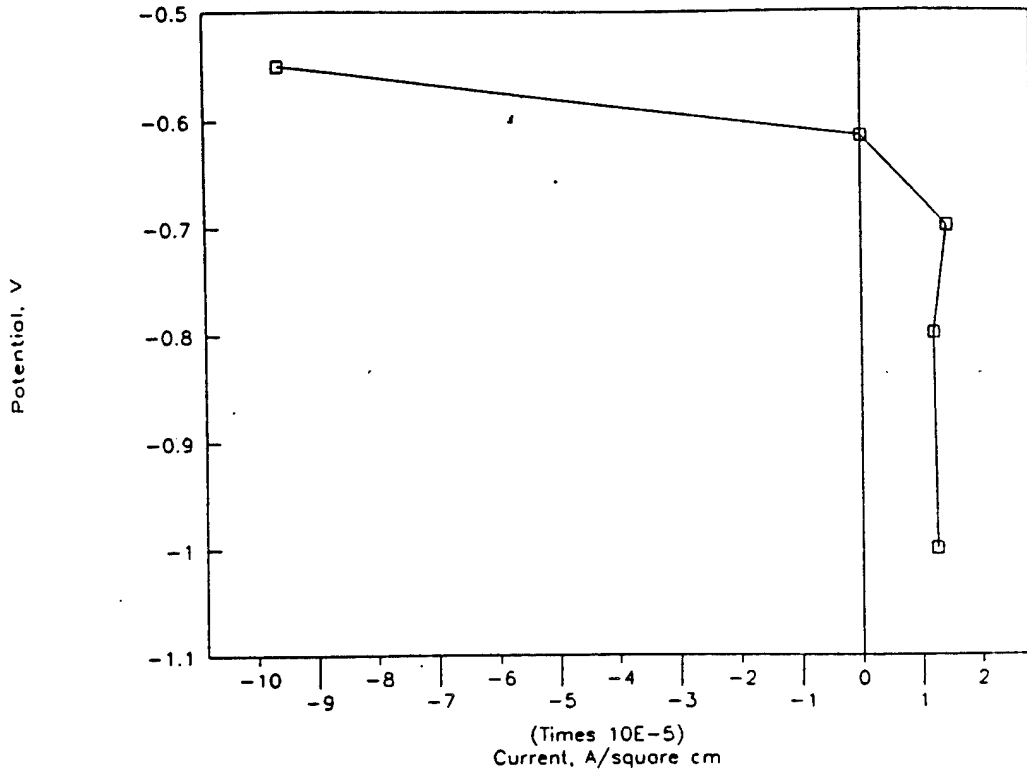
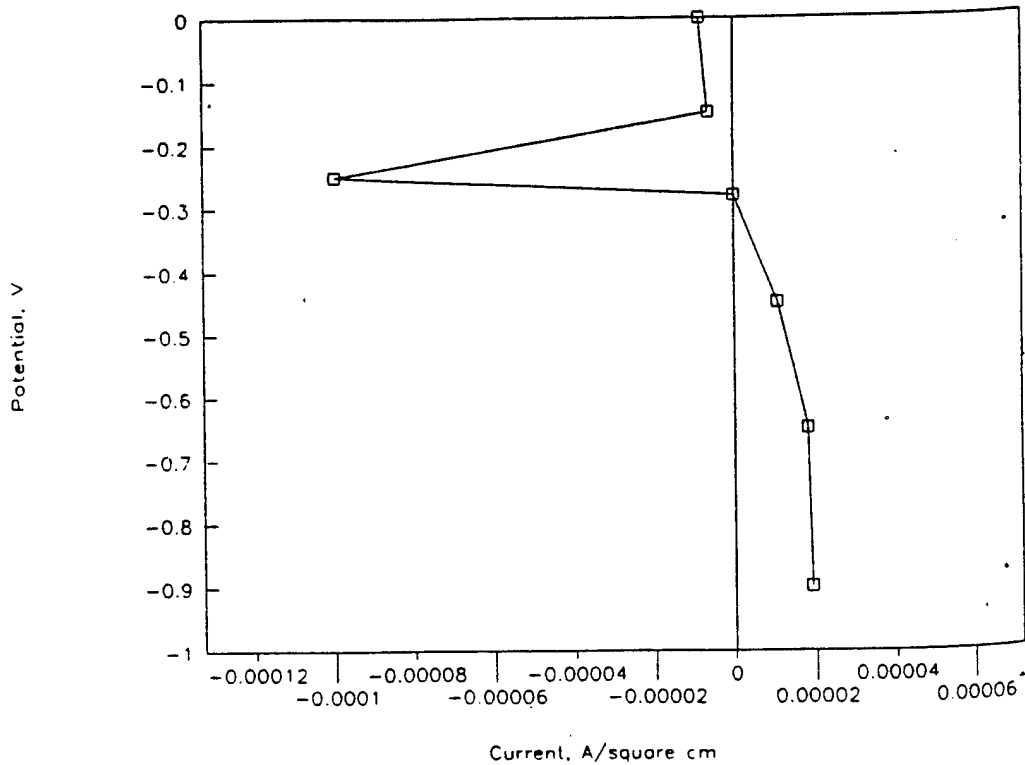

Figure 5 - Copper-Nickel Polarization Data



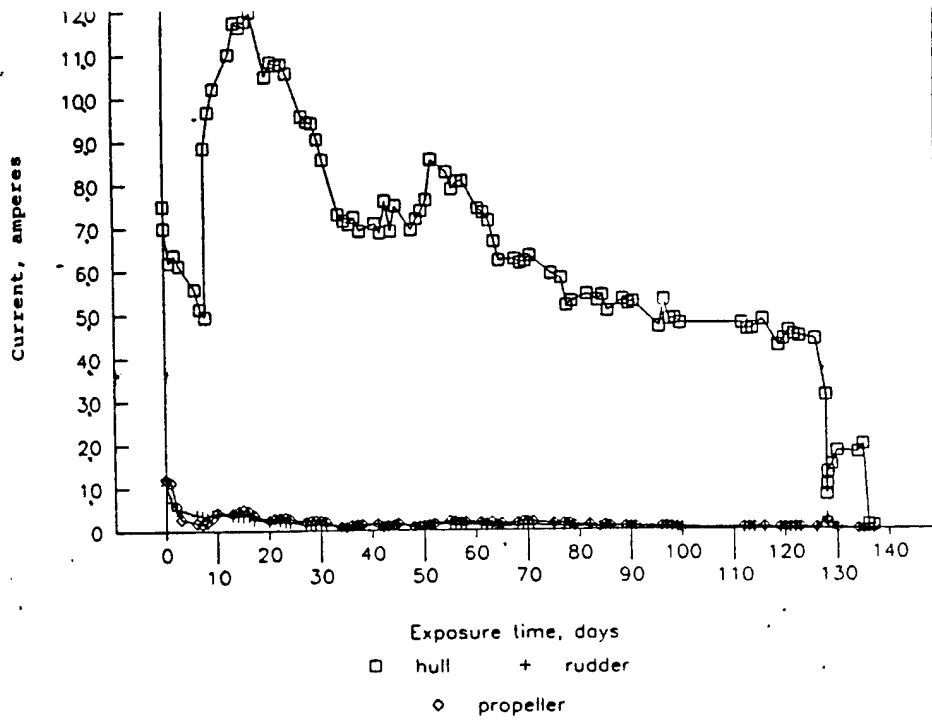

Figure 7 - Anode Currents

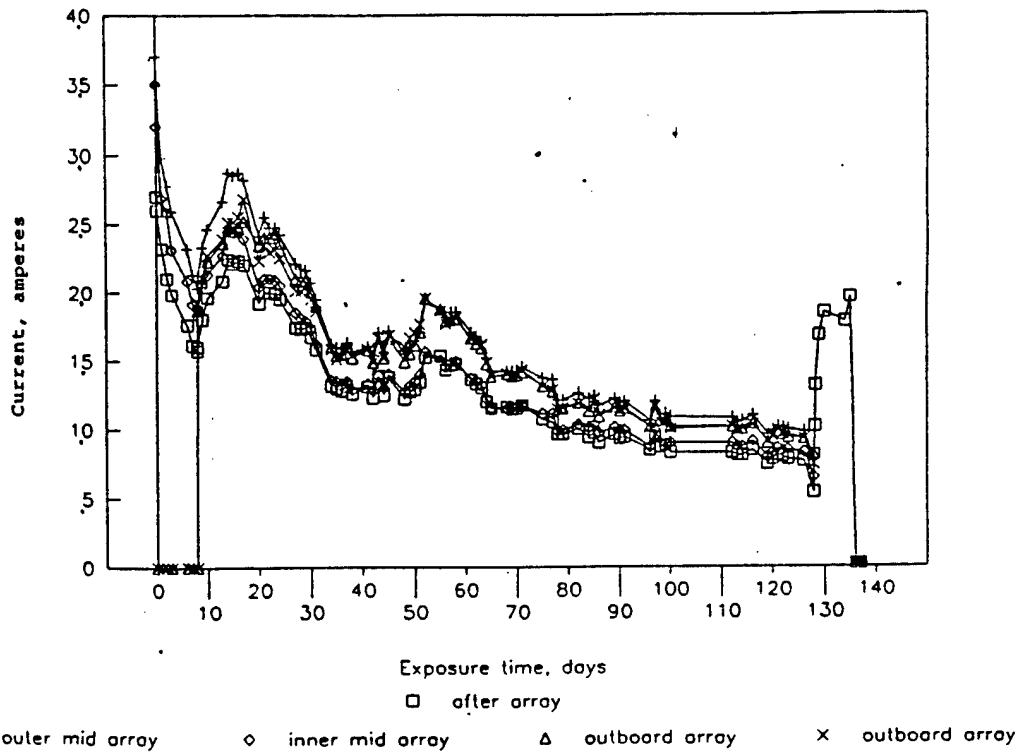

Figure 8 - Comparison of Model and Measured Potentials

