

# DRAFT SF 298

<b>1. Report Date (dd-mm-yy)</b>		<b>2. Report Type</b>		<b>3. Dates covered (from... to )</b>	
<b>4. Title &amp; subtitle</b> Cost-effective and Environmentally Safe Corrosion Prevention for 2nd Marine Air Wing Support Equipment Using Desiccant Wheel Dehumidification (DEW) Tri-Service Committee on Corrosion Proceedings			<b>5a. Contract or Grant #</b>		
			<b>5b. Program Element #</b>		
<b>6. Author(s)</b> Mr. David J. McCarthy MSGT Albert Sandoval MSGT Harry Miller			<b>5c. Project #</b>		
			<b>5d. Task #</b>		
			<b>5e. Work Unit #</b>		
<b>7. Performing Organization Name &amp; Address</b>				<b>8. Performing Organization Report #</b>	
<b>9. Sponsoring/Monitoring Agency Name &amp; Address</b> Tri-Service Committee on Corrosion USAF WRIGHT-PATTERSON Air Force Base, Ohio 45433				<b>10. Monitor Acronym</b>	
				<b>11. Monitor Report #</b>	
<b>12. Distribution/Availability Statement</b> Approved for Public Release Distribution Unlimited					
<b>13. Supplementary Notes</b>					
<b>14. Abstract</b>					
					
<b>15. Subject Terms</b> Tri-Service Conference on Corrosion					
<b>Security Classification of</b>			<b>19. Limitation of Abstract</b>	<b>20. # of Pages</b>	<b>21. Responsible Person (Name and Telephone #)</b>
<b>16. Report</b>	<b>17. Abstract</b>	<b>18. This Page</b>			

000955

# TRI-SERVICE CONFERENCE ON CORROSION



21-23 JUNE 1994

SHERATON PLAZA HOTEL  
ORLANDO, FLORIDA

## PROCEEDINGS

PROPERTY OF:

AMPTIAC LIBRARY

19971028 051

**Cost-effective and Environmentally Safe Corrosion Prevention  
for 2nd Marine Air Wing Support Equipment  
Using Desiccant Wheel Dehumidification (DEW)**

Mr. David J. McCarthy\*  
Munters Cargocaire  
79 Monroe St.  
Amesbury, MA 01912

MMSGT. Albert Sandoval, USMC (Ret)  
307 Tall Pine Road  
Havelock, NC 28582

MSGT. Harry Miller USMC (Ret)  
2040 Wells Rd. Apt. #5A  
Orange Park, FL 32073

**Introduction**

To reduce corrosion, equipment users and designers have essentially three choices: change the material, coat its surface or keep the item dry.

In an effort to reduce the cost and environmental impact of maintaining contingency support equipment, the 2nd Marine Air Wing (2nd MAW) has successfully utilized desiccant wheel dehumidification equipment to prevent corrosion by surrounding the material with dry air. 2nd MAW has found this greatly reduces the need for petroleum-based coatings, lubricants and corrosion-inhibitors, which improves compliance with environmental program goals while reducing costs. The DEW program also allows the 2nd MAW to redirect scarce man-hours to in-service equipment, maintaining high optempo capability in spite of reduced manpower. In implementing this program, the organization has reduced the need for appropriations of either capital or operating and maintenance funds by using existing manpower, equipment and supplies.

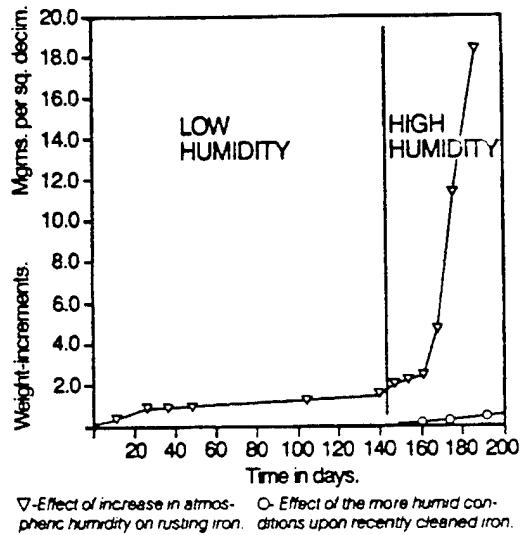

Figure 1. Corrosion rates depend on relative humidity (1)

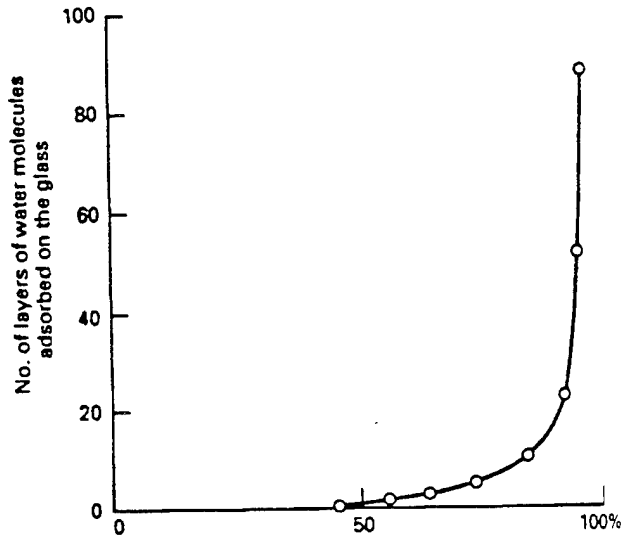

Figure 2. Corrosion increases because more water molecules settle on the surface at higher rh (2)

### Keeping Equipment Dry

The idea of preserving material by keeping it dry is not new. In the most obvious example, valuable artifacts from Egyptian tombs have been preserved by dry air for more than 3,000 years.

As early as 1927, the English electrochemist W.H.J. Vernon observed the close relationship between the relative humidity in the environment and the rate of corrosion of ferrous metals (1). In more recent times, it has become clear that the number of water molecules adsorbed onto a surface held at room temperature is a function of the relative humidity of the air surrounding the surface(2). Figures 1 and 2 show the close correlation between the number of monolayers of water adsorbed on a surface and the rate of corrosion of ferrous metal as defined by Vernon in 1927.

The intuitive theory of keeping military equipment dry to reduce corrosion was reduced to practice following the Second World War. The U.S. Reserve fleet was protected by dry air generated by desiccant dehumidifiers, with results that were favorable enough to encourage the use of the method for long-term preservation of shore-side ships parts in Mechanicsburg, PA. and in Army warehouses as well. The history of this technique was reviewed in 1986 by the Army Materiel Command(3).

In the early 1970's, European military organizations, notably the Swedish and Danish Armed Forces, began a series of trials to assess the use of desiccant dehumidifiers to reduce corrosion of active-duty military hardware. Unlike the U.S. Military during the 80's, the smaller, less-well-supported military establishments of Europe have always been highly conscious of the cost of corrosion in terms of required replacement equipment, and the environmental impact of preservation liquids and solvents.

These tests were highly successful in terms of reducing costs and improving the mean time between failures (MTBF) of sensitive electronic equipment in aircraft and combat vehicles. (4,5,6) Consequently, dry air protection has become a common feature of corrosion control programs in Europe for everything from active-duty aircraft to main battle tanks in long-term storage. The practice is in widespread use throughout Scandinavia, Germany, France and the Netherlands, and U.S. Materiel stored in NATO depots has been protected in controlled humidity warehouses (CHW) since 1983.

As a result of these successes with desiccant technology, the Department of Defense initiated a DOD-wide pilot program to evaluate the economic potential of more widespread use of desiccant wheel (DEW) technology in CONUS installations. This investigation has been underway since 1978 as part of the ongoing program to evaluate foreign weapons (FWE) to fulfill US requirements. For the FWE program within the Marines, the 2nd Marine Air Wing, with headquarters at Cherry Point, North Carolina, has been the lead organization evaluating DEW technology.

### **2nd Marine Air Wing Evaluation of Desiccant Wheel Technology**

The 2nd MAW operates both rotary and fixed-wing aircraft from four locations: Cherry Point, NC, New River, NC, Cecil Field, FL and Beaufort, SC. Rotary wing aircraft include the UH-1N and AH-1N Cobra attack helicopters, the CH-46 Sea Knight and the CH-53 Sea Stallion transport helicopters. The primary fixed-wing aircraft within 2nd MAW is the AV-8B Harrier. Other fixed wing craft include the FA-18 Hornet jet, the EA-6B Prowler and the KC-130 Hercules tanker. Until recently, the 2nd MAW also maintained a large number of A-6E close air support jets as well.

Maintenance for these aircraft includes both organizational level tasks and the more specialized intermediate level tasks carried out by the Marine Aviation Logistics Squadrons (MALS) which are part of the air wing. These squadrons include MALS-14 at Cherry Point, MALS 26 and 29 at New River and MALS-31 at Beaufort. Because the 2nd MAW includes a wide variety of aircraft and a broad mix of maintenance activity from simple tasks to more complex intermediate maintenance, the organization was ideally suited to assess the real-world performance of desiccant technology in an operational environment.

While the final audit of the FWE program within the Navy is not yet complete, results to date are very encouraging. In May, 1994, a preliminary progress report on audit project #94-0016, prepared by the Naval Audit Service/Pensacola, estimates that dehumidification of in-service AV-8B Harrier aircraft within 2nd MAW has reduced humidity-related maintenance man-hours by 51%, increased mission-capable rates by 4% and lengthened the average avionics component MTBF by 33%. For the A-6E aircraft, the report estimates a 29% reduction in maintenance man-hours, and a 33% improvement in MTBF. The final report is expected in December 1994.

Since the FWE program has completed its preliminary investigation phase, the prototype desiccant equipment became available for other activity within 2nd MAW. That equipment has now been put to use throughout the organization in an effort to reduce the cost and environmental impact of maintaining contingency support equipment. As of June, 1994, more than 4,000 pieces of support equipment including generators, power supplies, recharger carts and portable inert gas bottles have been placed under dry air protection using 20 pieces of DEW equipment, much of which was originally acquired for the FWE program.

### **DEW Operating Principles**

Desiccant wheel dehumidifiers produce dry, warm air continuously. The desiccant, which adsorbs moisture from air, is formed in-place in a wheel. The wheel looks like corrugated fiberboard rolled into the shape of a drum, so that air can pass easily through the desiccant-lined corrugations. As the air passes through the wheel, its moisture is adsorbed by the desiccant so the air emerges from the wheel warm and dry. For example, if air entered the wheel from a foggy spring morning in South Carolina at a temperature of 55°F and 100% relative humidity, it would leave the wheel at about 95°F and 11 grains per pound moisture content—which is about 4% relative humidity.

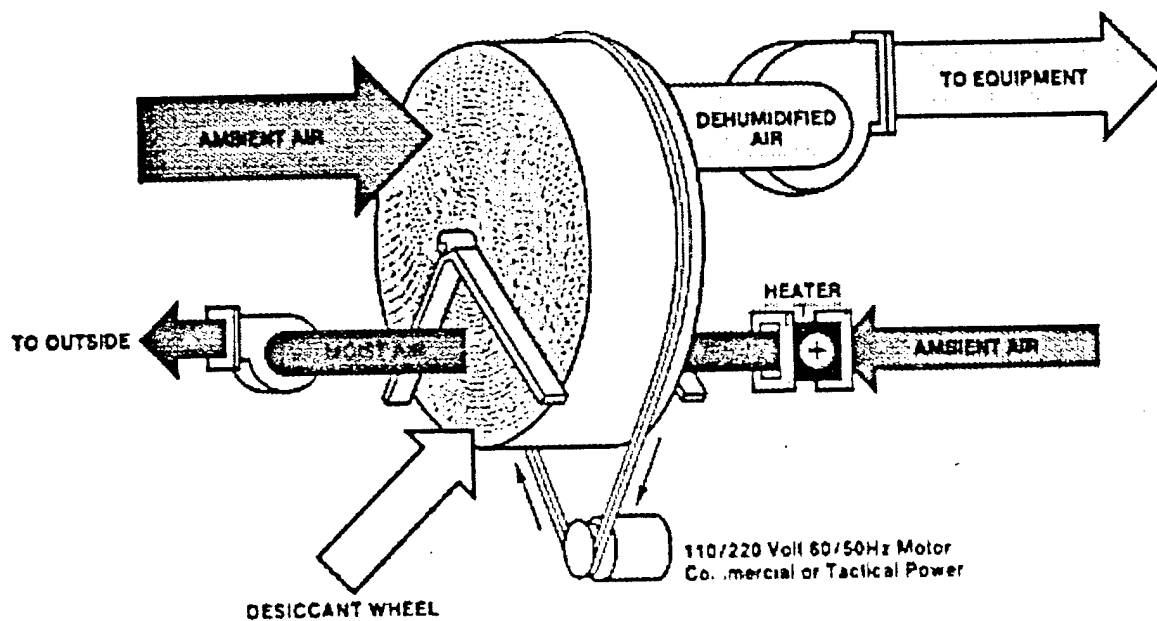
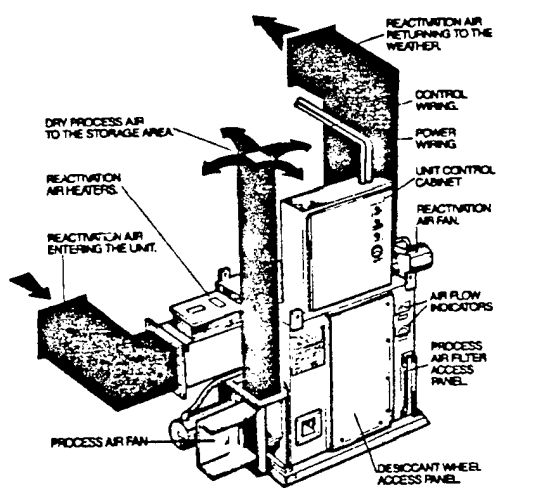

Figure 3. Desiccant Wheel (DEW) Operating Principles

The desiccant wheel rotates slowly (8 rph) between two counter-current air streams. The larger air stream, called the process air, is dried by the desiccant as explained above. As the wheel rotates through the process air and adsorbs moisture, the desiccant becomes saturated. But the wheel continues to rotate, passing through the smaller air stream, called the reactivation air. That air is heated, so it can remove the moisture from the desiccant. Since the wheel rotates continuously, it produces a constant stream of dry air. The desiccant wheel has a typical life of 350,000 cycles, which translates to five to ten years of normal operation before replacement is required.



The fact that the dehumidifier wheel rotates continuously gives it an important capacity advantage over the traditional passive desiccant storage technique of placing bags of desiccant around stored equipment. When bags of desiccant come to equilibrium with a high-humidity environment, they cannot absorb more moisture unless they are heated to drive off the moisture they have already adsorbed. A dehumidifier which operates continuously can remove hundreds or thousands of times more moisture than passive bags given the same amount of time.

Most will be familiar with the cooling-based dehumidifiers often sold for residential and commercial humidity control. Such equipment is quite inexpensive, but it suffers from two limitations which preclude its use in military applications. First, cooling-based dehumidifiers freeze when the weather is cool. When they freeze, such dehumidifiers lose all moisture removal capacity. Second, cooling-based units cannot dry air deeply enough to maintain the 30 to 40% rh that military organizations have found is necessary to eliminate the "sweating" (condensation) that causes corrosion when the weather moisture level rises rapidly around cold equipment.

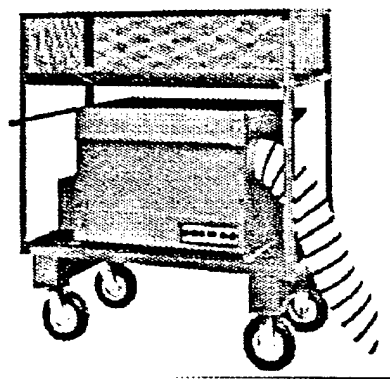

Figure 4. 300 cfm DEW unit

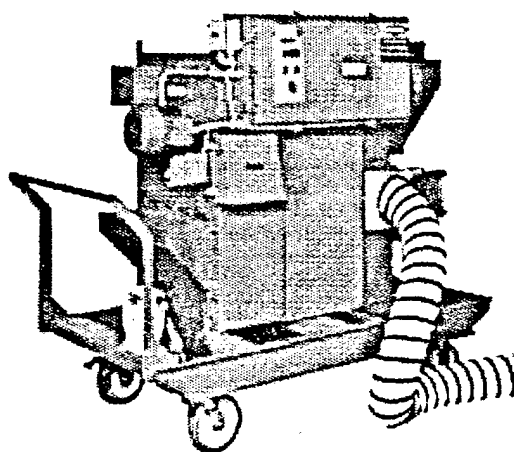

Figure 5. 600 cfm DEW unit

Figures 4 and 5 show typical DEW equipment used for military applications. The dehumidifier is mounted on a cart, which also holds the power cord and connecting hoses. Desiccant dehumidifiers need power for the process and reactivation air fans, desiccant wheel drive motor and the reactivation air heater. The smaller unit shown here provides 300 cubic feet per minute of dry air, and uses 6.75 kw of either 208-230 single-phase or 3-phase power, or 440-480 volt, 3-phase power. Equipment shown here meets the appropriate military requirements, including:

- Paint to MIL-C-46168 or MIL-C-53039
- Technical manuals to MIL-M-7298
- Rated for outdoor operation in temperatures from -40°F to 120°F

#### Methods of Using DEW Equipment For Dry Air Protection

DEW technology assumes that items protected from corrosion will be isolated and surrounded by dry air. In traditional controlled humidity warehouses, this is a simple condition to arrange. A tight building is equipped with a desiccant dehumidifier and dry air is circulated throughout the building whenever a humidistat indicates the humidity is above the set point. Such warehouses have been built by the hundreds all over the world in the last 45 years. Figure 6 shows a typical example. The structure is a small version of the several dozen erected in Europe to contain US military equipment assigned to NATO.

While these warehouses are certainly effective and very economical compared to alternative means of preventing corrosion, they are expensive when compared to the typical operating and maintenance budget of a Marine Air Wing. Large, dedicated controlled humidity warehouses require years of planning, and extensive military construction appropriations. Fortunately, there are less elaborate means of applying DEW equipment.

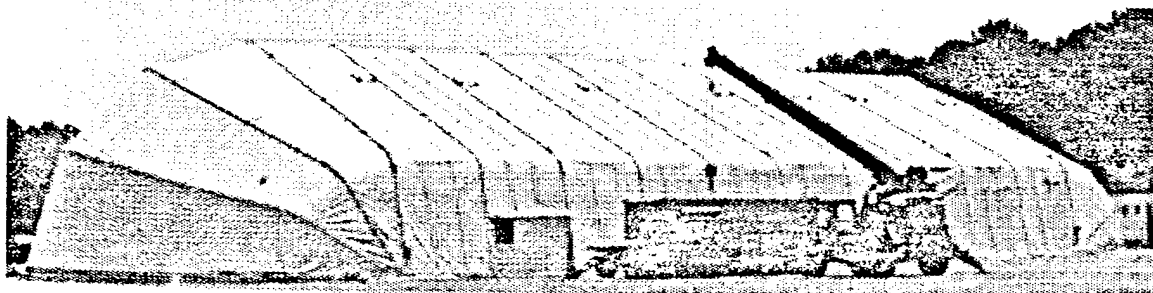
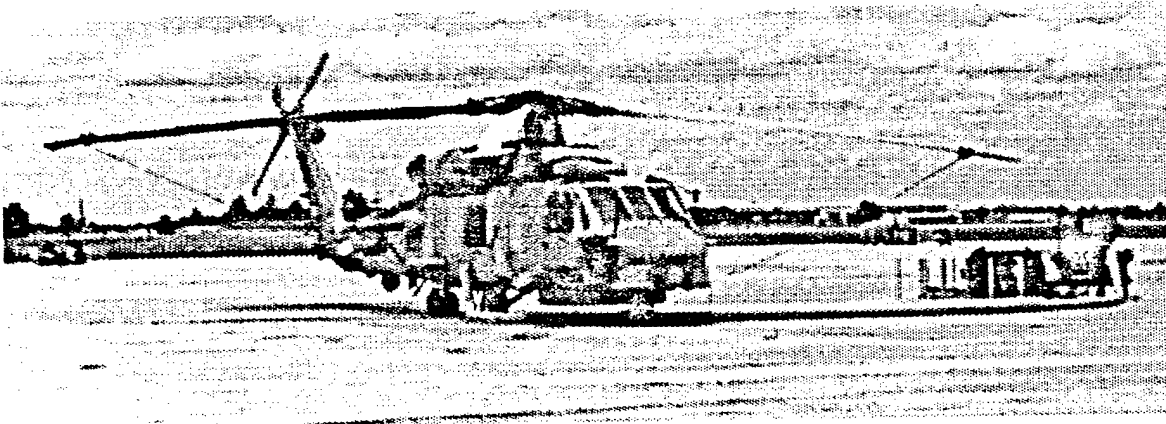
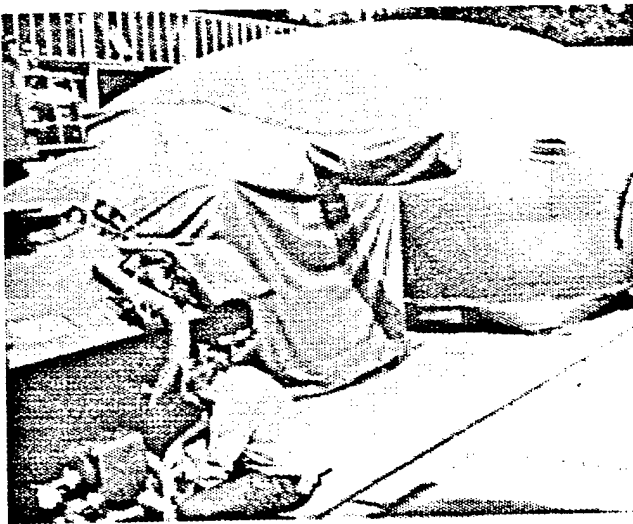

Figure 6. Larger versions of this type of shelter have been erected in Europe to protect NATO equipment



*Figure 7. DEW units can be connected directly to larger pieces of weather-tight equipment.*

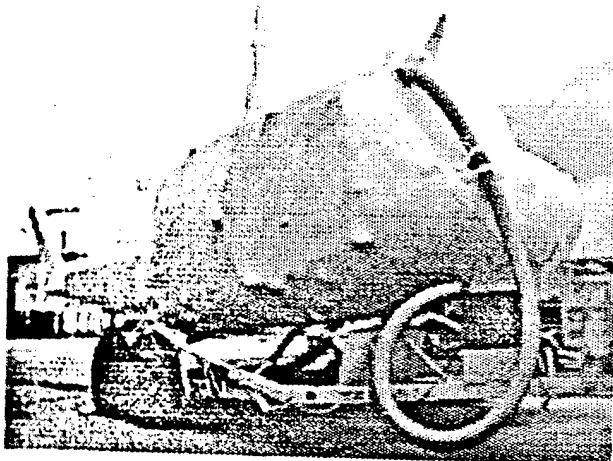

*Figure 8. If equipment must have weather protection when warehouses are not available, smaller shelters can be made economically and connected to DEW units.*

Figure 7 shows how DEW units can be connected directly to larger equipment. This configuration is commonly used for active-duty equipment which is basically weather-tight, and which must be available for action within minutes. Dry air from the DEW unit is blown into the helicopter through an 8" reinforced flexible air duct. The DEW unit operates continuously, purging the aircraft with dry air to prevent humid air from leaking into the aircraft.

Figure 8 shows another alternative. Heavy-duty reinforced vinyl fabric is made into fitted shelters which enclose the equipment under protection. Then a DEW unit is connected to the shelter and it circulates dry air throughout the enclosure. When the cover is loose, the DEW unit purges the shelter with fresh, dry air from the weather, putting the shelter under a slight positive air pressure to prevent humid air infiltration into the joints of the fabric. If the cover is tightly sealed, as is the cases with semi-permanent shelters, the DEW unit recirculates dry air within the enclosure, which reduces the operating time required to maintain the enclosure below the humidity set point.

Figure 9 shows a fourth option, in which equipment is shrink-wrapped for long-term storage or for ocean transport. Again, the DEW unit is connected to the shrink-wrapped enclosure to purge the equipment and prevent humid air infiltration. Experience with shrink-wrapped equipment is mixed. The method is easy to apply and can be made water-tight. But if the equipment contains water inside at the time of wrapping, a thin film



*Figure 9. For long-term storage or for ocean transport, equipment can be shrink-wrapped and connected to DEW units to eliminate internal sweating when temperatures change.*

of liquid can be trapped between the skin of the equipment and the wrapping material. Such films are nearly impossible to dry out because air does not circulate easily between the equipment and its tight wrapping. For shrink-wrapped equipment, dry air protection works best when the object is dried completely before the wrapping material is applied.

### **2nd MAW Support Equipment Dry Air Protection Program**

While all of the four classic, proven means of installing DEW units are cost-effective, they were still beyond the resources available to 2nd MAW. But the organization, like others, faces the prospect of reduced manpower and further budget reductions in the future. In short—the resources for corrosion protection are minimal, and are likely to decline further.

The problem is especially acute for contingency support equipment. While the contingency material awaits its next operational use, it must be maintained in accordance with the NA 17-1-125 support equipment corrosion control and preservation manual to ensure it will function properly when brought into active service. The procedures outlined in the manual call for a six-month maximum length of inactive storage. Twice every year, the equipment must be de-preserved, scheduled maintenance must be performed and then the equipment must be re-preserved with the appropriate fluids and coatings.

Experienced maintenance technicians know that these tedious, "by-the-book" requirements are not always followed faithfully and meticulously. However, even allowing for "creative documentation" and deferring these tasks when personnel are overworked, the fact is that 2nd MAW requires over 4,000 pieces of contingency equipment. The manpower required to ensure proper maintenance of that much preserved equipment becomes a substantial drain on skilled personnel resources.

Additionally, the environmental impact of such extensive use of petroleum-based solvents, oils, greases and hydraulic fluids is considerable. For example, MALS-29, located at New River, is responsible for 392 pieces of contingency support equipment. In order to properly preserve, de-preserve and maintain that equipment, compliance with preservation procedures requires the use of 6,173 gallons of fluids over three years. Much of that liquid is considered hazardous waste, which creates an additional burden for personnel in applying the liquid, and a cost burden on the organization when it must be properly disposed of.

Given the conditions of reduced manpower, no budget available for capital equipment or construction, and the need to minimize hazardous waste generation, 2nd MAW faced a

considerable challenge in maintaining contingency equipment. But such situations are familiar in the Marine Corps, since the service is often called on to accomplish large tasks with minimal resources.

The four MALS of 2nd MAW responded by using ingenuity and existing equipment to create dry enclosures within existing structures, and then connecting the existing DEW equipment from the FWE program to provide the humidity control within these enclosures. The program was entirely self-help within each MALS, requiring only minimal reprogramming of maintenance material for air barrier sheeting and in some cases support cables for the barriers.

### **Example 1 - Building 4183 - MALS-14 - Cherry Point, NC**

Building 4183 was originally built as an ordnance warehouse. In some respects, it was ideal for conversion to a controlled humidity facility, because it was insulated and has fairly tight, steel-panel walls. While there is no need for insulation in a humidity control situation, the insulation layer helps block air, which might otherwise infiltrate through joints in steel wall sections. The building measures approximately 70' x 100' with a 25' ceiling. The side-wall ventilation grills were cranked shut, and covered with polyethylene sheeting. The sheeting was taped to the building walls with ordnance tape. This cloth-reinforced tape is durable, and has an extremely aggressive tack. It is used for a wide variety of fast repairs and temporary fastening jobs. Apart from vent sealing, the only other air-tightening consisted of caulking obvious air leaks with standard construction-grade silicone sealant.

Initially, MALS-14 installed a DEW-300 desiccant wheel dehumidifier in the building. However, strip-chart humidity recorders located in the space showed that 300 cfm dehumidification capacity was not sufficient to keep the area between 30 and 40% rh.



*Left: The exterior of building 4183*

*Below: The inside of the building showing the DEW unit and simple air ducting*

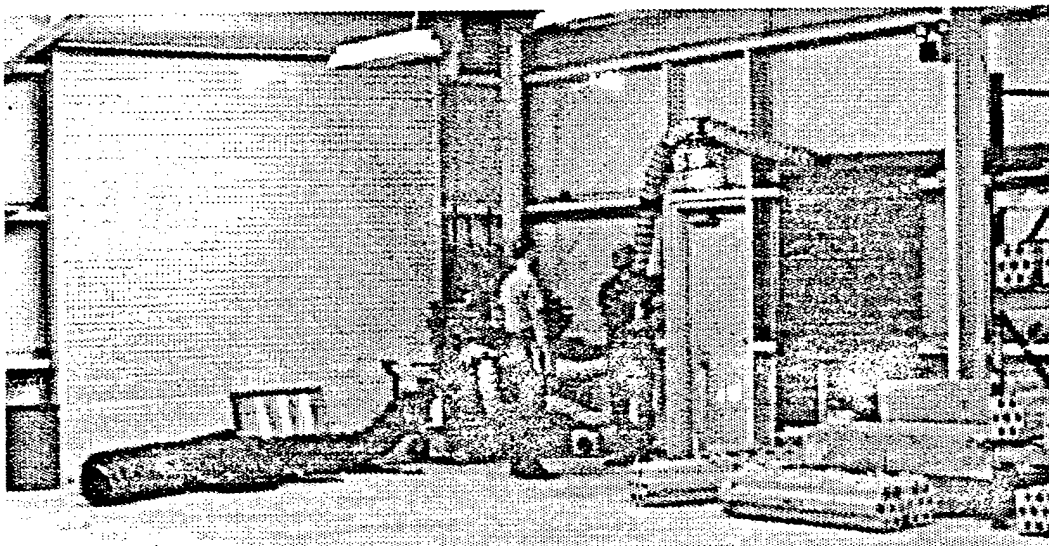

That control level is recommended by NAVAIR 15-01-500, the Navy's aircraft preservation manual, which outlines the use of DEW equipment for corrosion-prevention.

The 300 cfm unit was replaced with a 600 cfm DEW unit, but the humidity recorder still showed a failure to control humidity to 40% rh maximum. The recorder indicated that the building was maintained at 40% consistently between the middle of the morning up until about 7:00 P.M. in the evening. Then the humidity would rise above set point, sometimes reaching 65 to 70% rh by 2:00 am in the morning. So the inside condition tracked the weather. Note that this pattern is typical in all climates—during the day, the dry bulb temperature rises, but the dew point lags behind, so the relative humidity is low. But as the ambient temperature falls at night, it approaches the dew point closely—so the relative humidity registers close to saturation (100%rh). The initial assumption was that personnel were entering the building and leaving the doors ajar, but this was monitored and found not to be the case.

Careful investigation then uncovered the fact that a 4 in. x 12 ft. air gap existed out of sight at the top of each garage door opening between the rolling door and the building wall. The gap was needed to allow the rolling door sections to move smoothly into a roll as the door opens. To reduce air infiltration, MALS-14 obtained advice from the facilities management group on base. They cut strips of 1/8 in. rubber sheeting about 8" wide, and fastened the sheeting to the building with a 4" strip of galvanized flashing material through-bolted to the building wall. This arrangement forms a flexible wiper seal which allows the door to retract and extend smoothly, but greatly reduces the humid air infiltration—especially when the weather is windy. Now the 600 cfm dehumidifier has no difficulty keeping the humidity below 40% rh no matter what the weather is like.

The installation of the DEW unit is very simple. It sits inside the building near the personnel entry way. A flexible duct laid loose on the floor pulls humid air from the middle of the building into the process air inlet of the DEW unit. The dry air leaves the dehumidifier and is sent through 8"-round, galvanized steel duct work fastened to the wall. The air is carried up the wall, over the ceiling and discharged from a Y-connection near the roof. One leg of the Y blows air towards the center of the building, and the other sends air down one side wall. A humidistat is located in the middle of the space, such that dry air does not blow on the sensing element directly.

The cost of this installation was very low. The DEW unit and humidistat were obtained from the Army, which had completed its tests for the FWE program for the Blackhawk helicopter. The flexible process air inlet duct on the floor is recycled pre-heater hose, formerly used for air ducting for the pre-heaters used to warm tents and temporary shelters in field maneuvers. The galvanized process air distribution duct work was recycled from an old vehicle exhaust air system originally mounted in another building. And the material cost for polyethylene sheeting, ordnance tape, rolling door gaskets and construction caulk came to less than \$100. The building was converted to dry air storage in April of 1993, and has protected approximately 250 pieces of ordnance support equipment in excellent condition since that date.

#### **Example 2 - F-4 Training Facility - MALS-31 - Beaufort, SC**

This single-story building was originally built as a naval maintenance training facility for the F-4 jet. It measure 100' x 200' with 15' ceilings. The building consists of offices and classrooms, and several of these rooms have not been in use for several years. MALS-31 converted one of these rooms to a dry air storage area. The room measures 20' x 20' with a 15' ceiling. As the room was inside the building, and had been built for

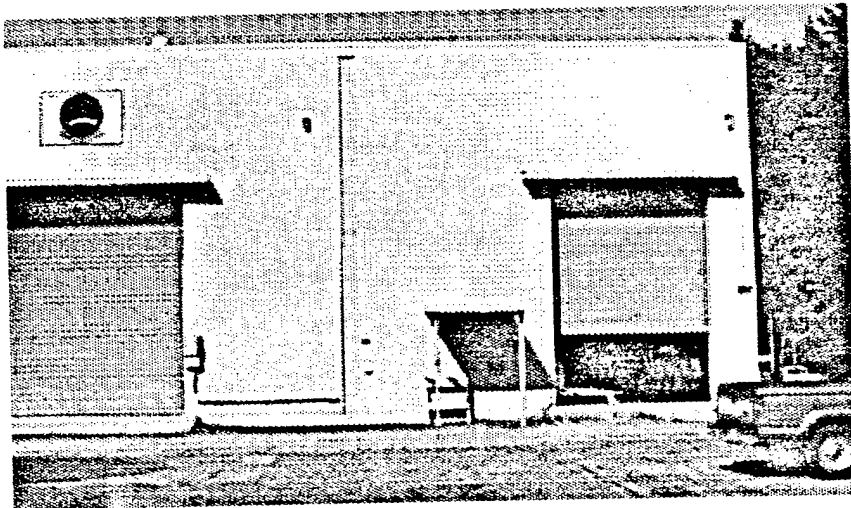

*Left: The exterior of the former F-4 Naval Maintenance Training Building. The room at the right formerly housed the hydraulic test stand training room and is now used for dry storage*

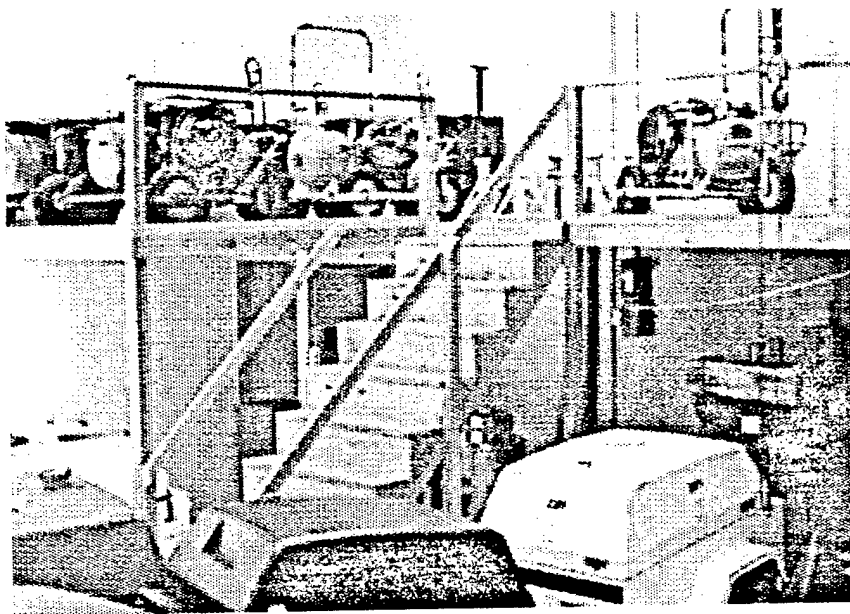

*Left: A second level was built from plywood and framing lumber to accommodate more equipment under dry air protection.*

normal classroom use, the walls, ceiling and floor were fairly airtight in comparison to hangers and warehouses. Also, the room had been used for training on hydraulic test stands, so it was equipped with a useful garage door so large equipment could move in and out of the building easily.

Any obvious cracks between walls and floor and ceiling were caulked with construction sealant, but little preparation was required. To make maximum use of the space, MALS-31 built a lumber-frame-and-plywood mezzanine above the floor level for smaller pieces of support equipment, while the floor level accommodates the larger items, so that up to 150 pieces can be protected in this small space.

Initially, a DEW-150 dehumidifier was used for humidity control. One useful feature of this small unit is its low energy consumption. It can operate on 110 volt, single phase power—ideal for smaller installations which generally have such current in all parts of the building. However, the unit ran continuously, indicating it was operating at or near its capacity in order to maintain the space at 40% rh. Additionally, a check of the unit showed that the reactivation air temperature leaving the unit was under 120°F. This low

temperature indicated that the desiccant wheel was not being completely dried on each rotation, confirming that the unit was working at or above its maximum capacity. The 150 unit was replaced with a DEW 300, and the expected favorable results were achieved. The 300 cfm unit operates intermittently, indicating that it has the needed capacity to meet peak loads when they occur.

In past experience with controlled humidity warehouses and tightly-sealed spaces such as the reserve fleet ships, dehumidifiers operate between 20 and 40% of the total hours in a month. Once the material stored in the facility loses its excess moisture and comes to equilibrium with the low humidity, the total moisture load on the dehumidifier reduces, and consists mainly of humid air infiltration. When air infiltration is minimized, the unit operates most frequently during evening hours when reductions in air temperature cause the relative humidity to rise above the control set point of 40% rh.

### **Example 3 - Fabric-on-frame Structure - MALS-31 - Beaufort, SC**

This building shows the type of buildings planned for dry storage within 2nd MAW. The program has achieved some impressive success at virtually zero capital cost, but nearly all the 58 units acquired through the termination of test programs have been redeployed. It will probably be necessary to invest in additional equipment in the future to continue gaining benefits from this technology. When that time comes, the organization currently plans to erect low-cost, but large-capacity shelters similar to this building at Beaufort. It measures 40' x 90' with a 30' ceiling. It now protects approximately 1,054 pieces of AWSE (Airborne Weapons Support Equipment).

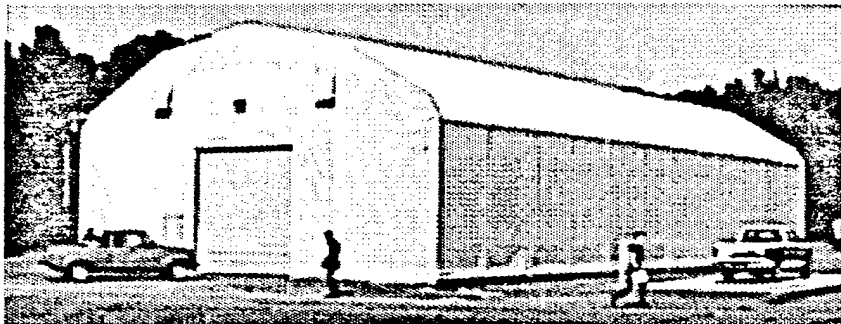

*This fabric-on-frame structure, originally procured for another mission, was easily converted to a dry storage facility by the addition of a DEW unit and minimal work to seal the walls to the concrete slab.*

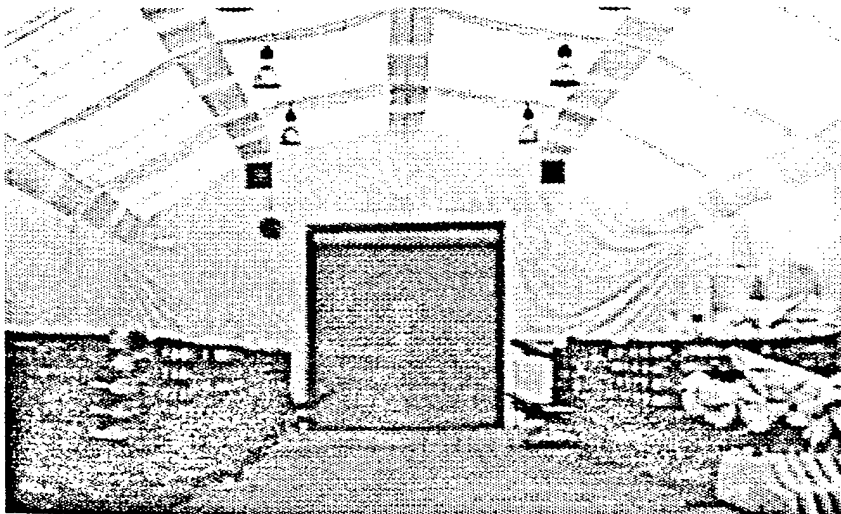

*Inside the structure, MALS-31 has placed approximately 1,054 pieces of contingency support equipment under dry air protection.*

Once again, this particular structure was originally used for a different purpose, but is nearly ideal for dry storage. The structural frame is lightweight steel tubing with cast steel joints. Over the frame, a durable reinforced vinyl fabric is stretched and secured with webbing and lanyard cord. The structure is relatively portable, and it can be erected without special equipment, by Marines with minimal experience in constructing buildings.

This particular shelter was erected over a poured concrete slab, which provides a durable floor for the storage of heavier equipment. But where such a slab is not available, the shelter could be provided with a plywood floor laid over low-cost 6 or 8-mil polyethylene sheeting. Some barrier is necessary to avoid water vapor infiltration from the moist ground under the shelter.

In this case, the fabric wall does not provide a watertight seal where the walls meet the concrete slab. This was improved considerably by simply running a bead of silicone construction caulk along the joint. Some leaks remain, but these are not apparently large enough to disturb the 40% rh control level.

The shelter is equipped with two DEW-600 units, one at each end of the structure. The units blow the process air (dry air) into the center of the space. Each unit is controlled by a separate humidistat. These are mounted in the middle of the structure, in a location that avoids direct contact with the process air stream.

This shelter, like all the dry storage areas within 2nd MAW, is equipped with a low-tech "moisture load reduction device". In other words, a sign on the personnel access door which clearly states: "This is a humidity-controlled room. Please keep the door shut." Just as a refrigerator cannot control temperature if its door is open, so will a dry storage room be difficult to maintain within specifications if moist air flows freely through the space.

### **Summary - Progress Report For The Dry Air Storage Program**

Within 2nd MAW, the dry air storage program is considered a success. Each MALS has plans to expand the program as resources allow. Interestingly, one of the unexpected aspects of the program is its popularity with the working-level personnel. The active-duty equipment FWE DEW program suffered initially from personnel resistance to "another new technology to learn". In contrast, the support equipment (SE) program has considerably reduced the unpleasant, boring and time-consuming chore of preserving and de-preserving equipment with fluids and oils. So the squadrons report that the program has enjoyed support at all levels. Those in charge of maintenance are favorably impressed with the increased availability of manpower for more critical mission requirements, and those who have to apply and clean the grease are glad to reduce the time they spend scrubbing equipment. Each MALS has made a preliminary assessment of the benefits of the program. These estimates are not official, nor have they been audited, but some of the points they have made in their reports include:

- **MALS-14 Cherry Point, NC**

148 pieces of equipment are currently under consideration for an expansion of dry air protection facilities. Based on their experience to date, the organization estimates that the projected five-year cost of past practices would be \$113,486. The same equipment under dry air protection would cost \$3,785 over the five-year period, for an estimated savings of \$109,701. In terms of manpower, past practices would consume 14,707 man-hours over five years, while the dry air program would require only 486 man-hours over the same period, allowing 14,221 hours to be redirected to more mission-critical tasks.

• MALS-31 - Beaufort, SC

A total of 372 pieces of equipment were eligible for the dry air program, but the organization only had space to accommodate 114 pieces. Maintenance required by NA-17-1-125 for all 372 items was reviewed and compared with the hours required under dry air protection. The total requirement would have been 7,768 hours, but that was reduced by 1,176 hours because of the 114 dry-protected items. At the standard manpower cost of \$16.00/hr, dry air protection allowed redirection of \$18,816 in manpower resources over the last year. MALS-31 is seeking funding to place an additional 10,000 sq.ft. under dry air protection, which they estimate will allow redirection of \$39,600 in manpower resources annually to more critical tasks in the future.

Mals-31 has not yet completed their benefit analysis for the 1,050 pieces of weapons support equipment under protection as described in example 3, but responsible personnel estimate that savings will be similar in proportion to the savings gained on the 114 pieces of other equipment under protection.

• MALS-29 - New River, NC

392 pieces of equipment were surveyed for preventive maintenance requirements. The total man-hours required for traditional preservation would be 535 per year, against a total of 7.3 man-hours for dry air protection.

Going beyond the other squadron's analyses of labor hours, MALS-29 has estimated the annual fluid requirement for each piece of equipment. The total comes to 6,173 gallons of hazardous liquid over three years with traditional preservation, against only 8.3 gallons for the same equipment under dry air protection.

The purchase cost of these liquids ranges between \$2.93 per gallon for MIL-L-2104DS engine oil to \$46.18/gal for P/N 75448 ferrous chemical conversion compound. Disposal costs vary between \$4.00 and \$8.00 per gallon. Using a typical disposal cost of \$6.00 per gallon, and a typical purchase cost of \$8.14 per gallon for hydraulic fluid, the liquid waste savings can be estimated at \$50,180 to purchase and \$36,988 for disposal over three years. In other words, in addition to freeing manpower resources, dry air protection provides an estimated \$29,056 that can be redirected to better uses each year by reducing the need for hazardous liquids.

Differences between these reports reflect the fact that different equipment is under protection in each MALS. Also, because this program was relatively informal and "self-help", there was no established test plan to bring the results to a single, consolidated conclusion. Now, since program results have been so positive, the Naval Aviation Preservation Program Managers at the Naval Aviation Depot at North Island, CA, have drafted a uniform test plan. This will be used in the coming year to simplify evaluation of future dry storage installations. But looking at the results of the last two years, one cannot help but be impressed that the working level managers certainly believe that the dimension of the savings is substantial, and that dry storage represents an excellent use of government resources compared to the expensive and wasteful practices of the past.

## References

1. Vernon, W.H.J., Second experimental report to the atmospheric corrosion research committee. Transactions of the Faraday Society, No. 23, 1927, pp.113-204
2. McHaffie, J.R. and Lehner, S., The adsorption of water from the gas phase on plane surfaces. J Chem. Soc, 127, 1559-1568, 1925.
3. Controlled humidity criteria evaluation, Project Report AMC-32-85, May 1986., U.S. Army Materiel Command, Packaging, Storage and Containerization Center, Tobyhanna, PA POC: Stuart Dougherty, Distribution Facilities Specialist
4. Niepoort, J. Protection of jet engines from corrosion by removal of moisture. Lecture at Vaerløse Air Base, Denmark, 1977
5. Dehumidification of aircraft, Report 389/86, Task 292/85, October 1986, Royal Air Force, Swanton Morley
6. Long-term storage of tanks, Review of EDAM Test Results (11 years of dry air storage), Bundeswehr Materialamt des Heeres (MatAH) TID-543, 15 October, 1987 , 5483 Bad Neuenahr-Arweiler