

15 OCT 1997

Environmental High Temperature Testing System

AFOSR Equipment Grant (F49620-95-1-0484)
Final Report (July 1995 - June 1997)



October 6, 1997

Minoru Taya, Albert S. Kobayashi, and Michael Jenkins
Department of Mechanical Engineering
University of Washington
Seattle, WA 98195

DTIC QUALITY INSPECTED 3

DISTRIBUTION STATEMENT A
Approved for public release;
Distribution Unlimited

REPORT DOCUMENTATION PAGE

Public reporting burden for this collection of information is estimated to average 1 hour per response, including gathering and maintaining the data needed, and completing and reviewing the collection of information. Send collection of information, including suggestions for reducing this burden, to Washington Headquarters Service, Davis Highway, Suite 1204, Arlington, VA 22202-4302, and to the Office of Management and Budget, Paperwork Reduction Project (0550-0047).

0550

nces,
this
erson

1. AGENCY USE ONLY (Leave blank)		2. REPORT DATE Oct. 6, 1997	3. REPORT TYPE AND DATES COVERED Final (7/1995 - 6/1997)	
4. TITLE AND SUBTITLE AFOSR Equipmental Grant on Environmental High Temperature Testing System			5. FUNDING NUMBERS F49620-95-1-0484	
6. AUTHOR(S) M. Taya, A.S. Kobayashi, and M. Jenkins				
7. PERFORMING ORGANIZATION NAME(S) AND ADDRESS(ES)			8. PERFORMING ORGANIZATION REPORT NUMBER UW-ME-97-001	
9. SPONSORING/MONITORING AGENCY NAME(S) AND ADDRESS(ES) Dr. Walter F. Jones/Dr. Ozden O. Ochoa Mechanics & Materials Program, Aerospace Science AFOSR Bolling AFB, DC 20332-6448			10. SPONSORING/MONITORING AGENCY REPORT NUMBER 11A	
11. SUPPLEMENTARY NOTES			19971103 060	
12a. DISTRIBUTION/AVAILABILITY STATEMENT Unlimited Approved for public release; distribution unlimited.			12b. DISTRIBUTION CODE	
13. ABSTRACT (Maximum 200 words) A new high temperature testing system was designed with capabilities of fast heating/cooling, minimum effective heating zone focusing only on specimen gauge length area. The tension/compression testing can be performed in air, vacuum, or inert gas environment at high temperatures up to 1700 degrees Celsius while the displacement of a specimen measured by a new Argon laser interferometry system. The target specimens are ceramics, metals, intermetallics, composites including carbon/carbon composites. The furnace is infrared image furnace with gold plated elliptical reflectors to create a focused effective high temperature zone.				
14. SUBJECT TERMS High Temperature Testing, Laser Interferometry, Infrared Image Furnace			15. NUMBER OF PAGES 7	
			16. PRICE CODE	
17. SECURITY CLASSIFICATION OF REPORT unclassified	18. SECURITY CLASSIFICATION OF THIS PAGE unclassified	19. SECURITY CLASSIFICATION OF ABSTRACT unclassified	20. LIMITATION OF ABSTRACT	

REPORT DOCUMENTATION PAGE

Form Approved
OMB No. 0704-0188

Public reporting burden for this collection of information is estimated to average 1 hour per response, including the time for reviewing instructions, searching existing data sources, gathering and maintaining the data needed, and completing and reviewing the collection of information. Send comments regarding this burden estimate or any other aspect of this collection of information, including suggestions for reducing this burden, to Washington Headquarters Services, Directorate for Information Operations and Reports, 1215 Jefferson Davis Highway, Suite 1204, Arlington, VA 22202-4302, and to the Office of Management and Budget, Paperwork Reduction Project (0704-0188), Washington, DC 20503.

1. AGENCY USE ONLY (Leave blank)	2. REPORT DATE Oct. 6, 1997	3. REPORT TYPE AND DATES COVERED Final (7/1995 - 6/1997)
---	---------------------------------------	--

4. TITLE AND SUBTITLE AFOSR Equipmental Grant on Environmental High Temperature Testing System	5. FUNDING NUMBERS F49620-95-1-0484
--	---

6. AUTHOR(S) M. Taya, A.S. Kobayashi, and M. Jenkins
--

7. PERFORMING ORGANIZATION NAME(S) AND ADDRESS(ES)	8. PERFORMING ORGANIZATION REPORT NUMBER UW-ME-97-001
---	---

9. SPONSORING/MONITORING AGENCY NAME(S) AND ADDRESS(ES) Dr. Walter F. Jones/Dr. Ozden O. Ochoa Mechanics & Materials Program, Aerospace Science AFOSR Bolling AFB, DC 20332-6448	10. SPONSORING/MONITORING AGENCY REPORT NUMBER
---	---

11. SUPPLEMENTARY NOTES

12a. DISTRIBUTION/AVAILABILITY STATEMENT Unlimited Approved for public release; distribution unlimited.	12b. DISTRIBUTION CODE
---	-------------------------------

13. ABSTRACT (Maximum 200 words) A new high temperature testing system was designed with capabilities of fast heating/cooling, minimum effective heating zone focusing only on specimen gauge length area. The tension/compression testing can be performed in air, vacuum, or inert gas environment at high temperatures up to 1700 degrees Celsius while the displacement of a specimen measured by a new Argon laser interferometry system. The target specimens are ceramics, metals, intermetallics, composites including carbon/carbon composites. The furnace is infrared image furnace with gold plated elliptical reflectors to create a focused effective high temperature zone.
--

14. SUBJECT TERMS High Temperature Testing, Laser Interferometry, Infrared Image Furnace	15. NUMBER OF PAGES 7
	16. PRICE CODE

17. SECURITY CLASSIFICATION OF REPORT unclassified	18. SECURITY CLASSIFICATION OF THIS PAGE unclassified	19. SECURITY CLASSIFICATION OF ABSTRACT unclassified	20. LIMITATION OF ABSTRACT
--	---	--	-----------------------------------

GENERAL INSTRUCTIONS FOR COMPLETING SF 298

The Report Documentation Page (RDP) is used in announcing and cataloging reports. It is important that this information be consistent with the rest of the report, particularly the cover and title page. Instructions for filling in each block of the form follow. It is important to *stay within the lines* to meet optical scanning requirements.

Block 1. Agency Use Only (Leave blank).

Block 2. Report Date. Full publication date including day, month, and year, if available (e.g. 1 Jan 88). Must cite at least the year.

Block 3. Type of Report and Dates Covered. State whether report is interim, final, etc. If applicable, enter inclusive report dates (e.g. 10 Jun 87 - 30 Jun 88).

Block 4. Title and Subtitle. A title is taken from the part of the report that provides the most meaningful and complete information. When a report is prepared in more than one volume, repeat the primary title, add volume number, and include subtitle for the specific volume. On classified documents enter the title classification in parentheses.

Block 5. Funding Numbers. To include contract and grant numbers; may include program element number(s), project number(s), task number(s), and work unit number(s). Use the following labels:

C - Contract	PR - Project
G - Grant	TA - Task
PE - Program Element	WU - Work Unit Accession No.

Block 6. Author(s). Name(s) of person(s) responsible for writing the report, performing the research, or credited with the content of the report. If editor or compiler, this should follow the name(s).

Block 7. Performing Organization Name(s) and Address(es). Self-explanatory.

Block 8. Performing Organization Report Number. Enter the unique alphanumeric report number(s) assigned by the organization performing the report.

Block 9. Sponsoring/Monitoring Agency Name(s) and Address(es). Self-explanatory.

Block 10. Sponsoring/Monitoring Agency Report Number. (If known)

Block 11. Supplementary Notes. Enter information not included elsewhere such as: Prepared in cooperation with...; Trans. of...; To be published in.... When a report is revised, include a statement whether the new report supersedes or supplements the older report.

Block 12a. Distribution/Availability Statement. Denotes public availability or limitations. Cite any availability to the public. Enter additional limitations or special markings in all capitals (e.g. NOFORN, REL, ITAR).

DOD - See DoDD 5230.24, "Distribution Statements on Technical Documents."

DOE - See authorities.

NASA - See Handbook NHB 2200.2.

NTIS - Leave blank.

Block 12b. Distribution Code.

DOD - Leave blank.

DOE - Enter DOE distribution categories from the Standard Distribution for Unclassified Scientific and Technical Reports.

NASA - Leave blank.

NTIS - Leave blank.

Block 13. Abstract. Include a brief (*Maximum 200 words*) factual summary of the most significant information contained in the report.

Block 14. Subject Terms. Keywords or phrases identifying major subjects in the report.

Block 15. Number of Pages. Enter the total number of pages.

Block 16. Price Code. Enter appropriate price code (*NTIS only*).

Blocks 17. - 19. Security Classifications. Self-explanatory. Enter U.S. Security Classification in accordance with U.S. Security Regulations (i.e., UNCLASSIFIED). If form contains classified information, stamp classification on the top and bottom of the page.

Block 20. Limitation of Abstract. This block must be completed to assign a limitation to the abstract. Enter either UL (unlimited) or SAR (same as report). An entry in this block is necessary if the abstract is to be limited. If blank, the abstract is assumed to be unlimited.

Summary

AFOSR Equipmental Project, entitled "Environmental High Temperature Testing System for Advanced Structural Materials" (High Temperature Testing System, in short) was completed March 31, 1997. The system consists of three major parts: Tension/Compression Instron 8562 system, Sinku-Riko Image Furnace System and Innova 308 Argon-Ion Laser System.

This High Temperature Testing System has several features that others do not have: fast heating/cooling by using the image furnace system, and strain measurement by laser interferometry system. Currently we are still calibrating the whole system by examining each system first, i.e., the Instron 8562 system with image furnace and laser interferometry system. The high temperature testing system is helping the PI (Taya) for his current parent AFOSR grant on thermomechanical behavior of functionally graded materials (F49620-96-1-0158), Co-PI (Kobayashi) for his AFOSR grant on failure process zone modeling (F49620-93-2-0210) and Co-PI (Jenkins) for his DOE grant on continuous fiber ceramic matrix composites (subcontract of Lockheed Martin ERC DE-AC05-84OR21400).

The details of each subsystem and whole system are given in the text.

1. Introduction

A standard high temperature testing system consists of a mechanical tester surrounded by a high temperature furnace of resistance heat source which is in turn surrounded by an environmental chamber where the measurement of strains is normally done by a high temperature extensometer. The disadvantages of such a standard high temperature testing system are expensive cost of whole system, slow heating/cooling capability and large heat mass adversely affecting the grips and surrounding parts. Under the AFOSR equipmental grant we designed a new type of high temperature testing system, where the above disadvantages are eliminated, i.e., cost effectiveness, fast heating/cooling capability and keeping the grips and surrounding parts in good conditions even for high temperatures imposed on specimen gauge length area.

The high temperature testing system consists of a mechanical tester (Instron 8562 tension/compression frame with high temperature grips), high temperature vacuum furnace (Sinku-Riko infrared image furnace system with VHT-E68 model) and laser interferometry system (Innova 308 Argon Ion Laser). Schematic illustration of the system is shown in Fig. 1.

Currently, we are still calibrating each subsystem and expect to assemble them into the whole system and use it as it is originally designed. In the main text, we shall describe the details of each subsystem.

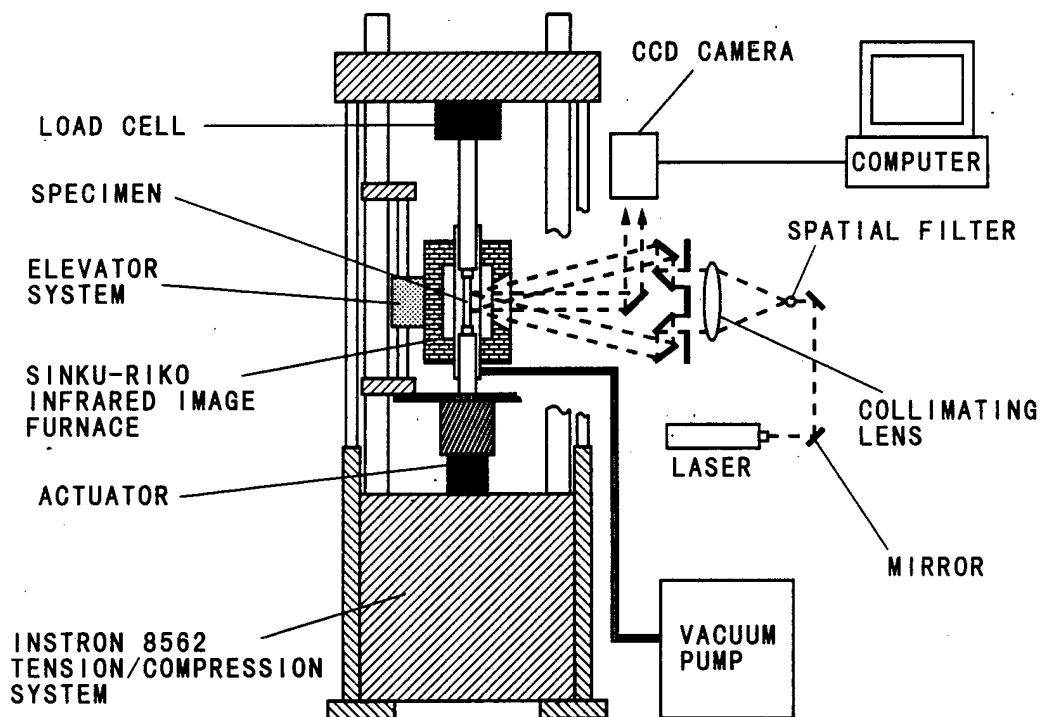

Fig. 1 High temperature testing system

2. Mechanical Tester

This Instron 5862 system has a capacity of tension/compression of 250 kN (55 Kip) with electric actuator and water-cooled high temperature grip (of 22 Kip capacity). The frame has an extra large daylight height of 93 inches to accommodate a special vacuum furnace. The sequence of mounting a specimen is schematically shown in Fig. 2 where (a), (b), (c), and (d) denote, respectively, the configuration of the testing system with specimen, moving the upper unit with upper part of a broken specimen, moving the lower unit with lower part of the broken specimen and mounting a new specimen and lowering the upper unit. This apparently cumbersome sequence stems from the fact that the specimen is surrounded by quartz tube inside which small-sized environmental chamber is located. The smallness of the environmental chamber (vacuum, inert gas, etc.) is the advantage of our design as compared with large environmental chamber common to other high temperature testing systems.

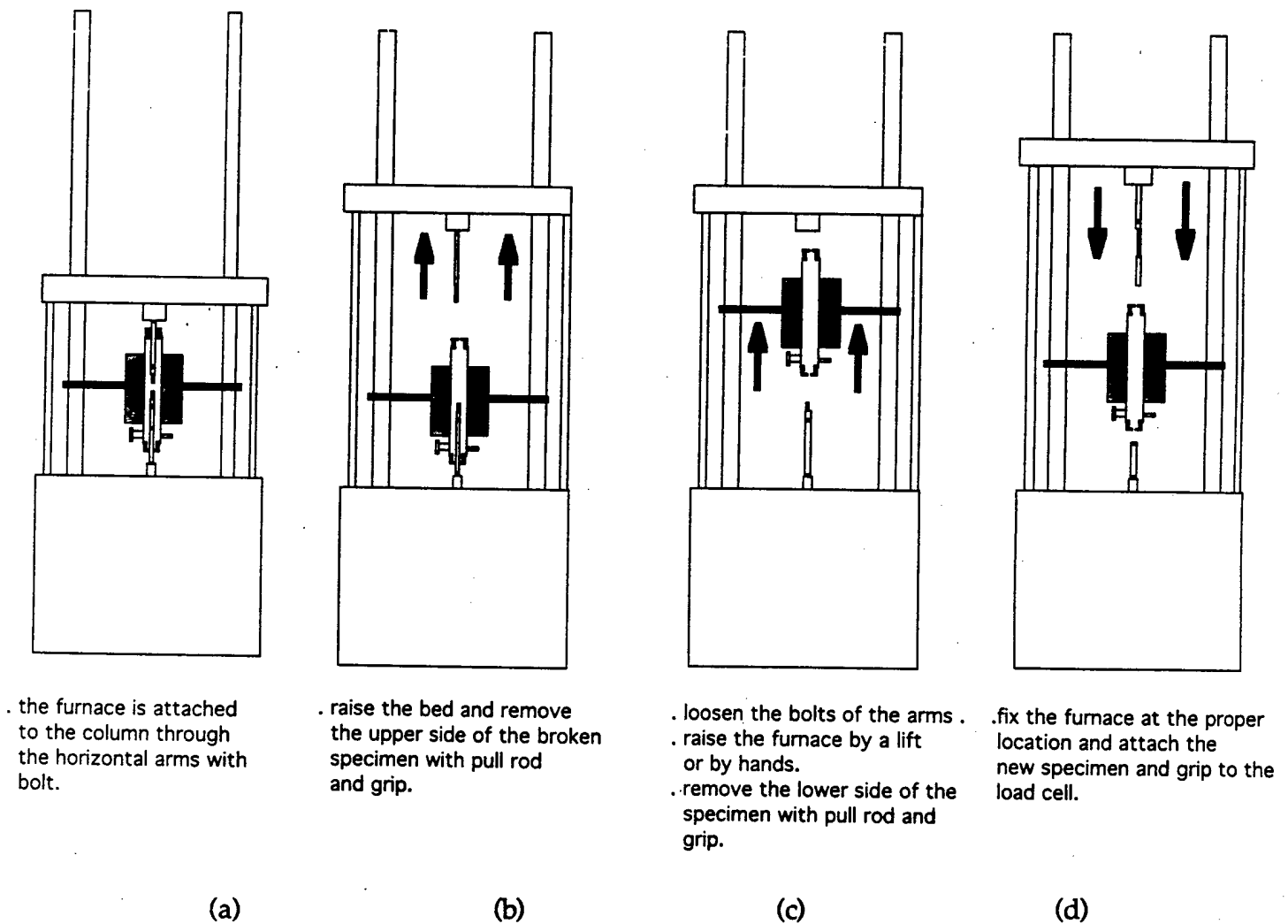

Fig. 2 Sequence of unloading and mounting a specimen

3. Infrared Image Furnace

The Sinku-Riko infrared image furnace has a capability of the maximum temperature 1700°C for a short time and use temperature up to 1500°C for longer times. The environment within the furnace is air, inert gas or vacuum. The heat sources are infrared tubular heating with gold plated elliptical reflectors. The effective heating area is 20 mm diameter and 200 mm long while the uniform temperature zone is 15 mm diameter and 70 mm long. The heating rate is 100°C/min. while the cooling rate depends on natural radiation of specimen itself and grip part, and can be faster by flushing cool air jet into specimen zone. The heating unit consists of 6 infrared lamp with the total power of 36 kw, supplied by electric power of 220 VAC 38 KVA and three phases. Temperature of the furnace is controlled by programmable controller (model TPC1-3-36) with P.I.D. and fudgy control.

The Sinku-Riko infrared image furnace system is to be mounted to the Instron 8562 mechanical testing system as illustrated in Fig. 3 where (a) and (b) denote the profile view with the Instron tester and details of the longitudinal cross section view, respectively, with dimensions in mm unit. Please note in Fig. 3(b) that there is an access window of laser beam for measurement of displacement of a specimen along the vertical (axial) direction and also evacuation port for vacuuming and inert gas flow.

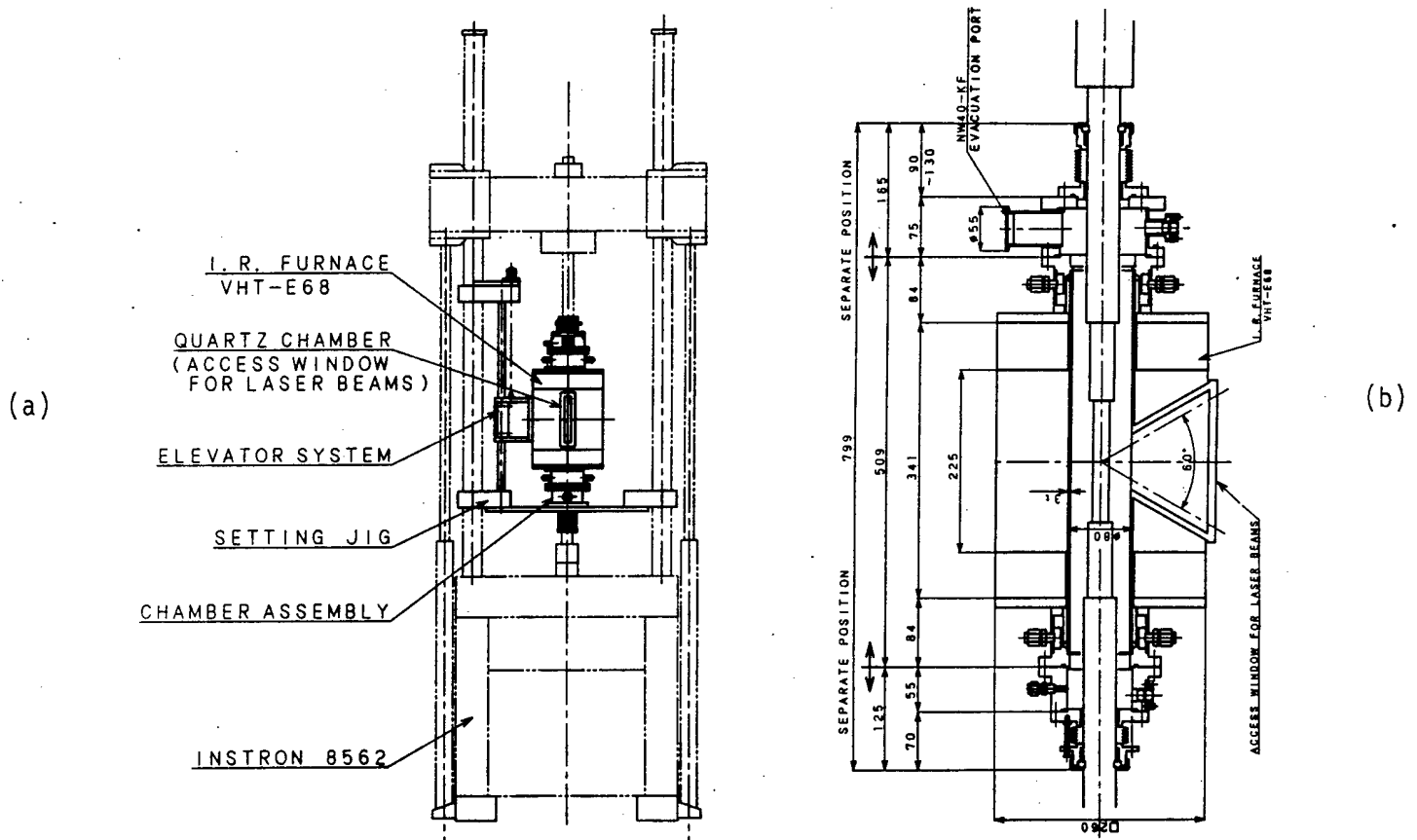

Fig. 3 Sinku-Riko Infrared Image Furnace System
 (a) profile as it is mounted to the Instron 8562 tension/compression tester,
 (b) magnified view of the longitudinal cross section

4. Laser Interferometry System

This system is designed to be a part of the proposed high temperature testing system, Fig. 1. Before making such a system, we first used the purchased 8 watt 308 Argon-Ion laser to create a holographic grating with a frequency of 1,200 lines per mm on a photoresist film. The process, which was developed during the past year, is to evaporate a thin nichrome film onto the polished surface of an alumina specimen, deposit a photoresist mask of 1,200 lines per mm on top of the nichrome film by interferometry technique, and then etch in ceric ammonium nitrate solution. The result is a thin nichrome grating of square dots with a frequency of 1,200 lines per mm on top of the alumina specimen. This grating can be used for Moiré interferometry, as shown by a hypothetical test setup of Figure 4, at testing temperature up to 800°C and possibly to 1000°C which is beyond the glassy phase of alumina.

The phase shifting Moiré interferometry was then used to study the fracture process zone (FPZ) in ceramics at room temperature. The phase shifting procedure provided an added order of magnitude to the sensitivity of the 1200-lines/mm Moiré grating which in itself lacked the sensitivity for analyzing the brittle alumina. The utility of the phase shifting Moiré interferometry was demonstrated by a room temperature, slow crack growth study of an alumina WL-DCB specimen, Fig. 5. The recorded wedge opening displacement and the crack growth data were used to drive a finite element model of the alumina wedge-loaded double-cantilever beam (WL-DCB) specimen in its generation mode from which the crack bridging force and the crack growth resistance curve were extracted through an inverse process by matching the measured and recorded crack opening displacements as shown in Figure 6. The dissipated energy in the FPZ was also computed, as expected, were found to be in excess of 99 percent of the energy released during stable crack growth as shown in Figure 7.

High-temperature fracture analysis with the Innova 308 Argon-Ion Laser will be undertaken during this academic year.

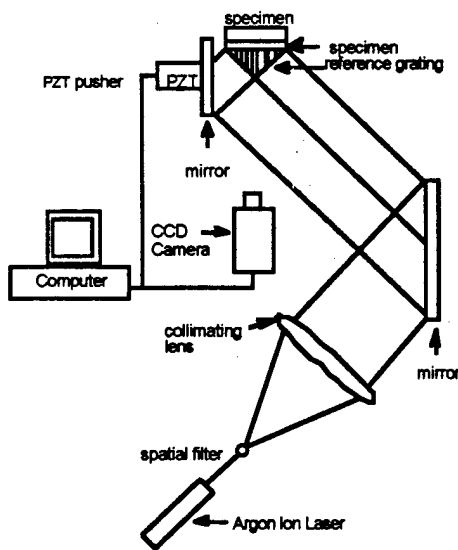

Fig. 4 Phase shifting Moiré interferometry setup

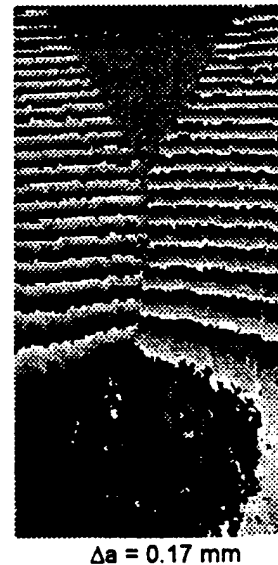

Fig. 5 Phase shifting Moiré pattern of alumina specimen

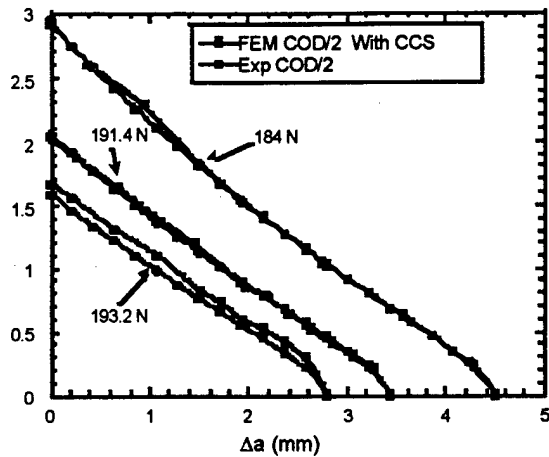

Fig. 6 COD profile vs crack extension of alumina

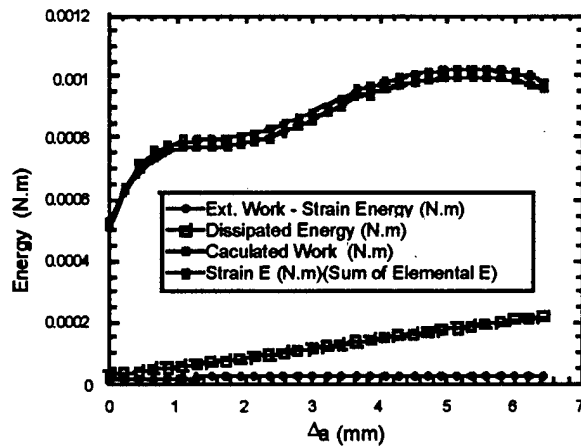

Fig. 7 Energy vs crack extension of alumina

Conclusion

A new high temperature testing system was designed with the following features:

1. Fast heating/cooling capability without affecting the grips and surrounding parts.
2. Specimen can be tested under tension or compression, and by some modifications of the grip mounting unit, bending tests can also be performed in air, vacuum or inert gas environment.
3. Vertical displacement of a specimen can be measured by laser interferometry system with 8 watt Argon laser.
4. Several calibrating works remain to be made to make this system operable under designed loading.
5. Multiple users both on campus and off campus are expected to use this system in addition to the current PI (Taya) and Co-PIs (Kobayashi and Jenkins).

Table of Contents

	Page
1. Introduction	1
2. Mechanical Tester	2
3. Image Furnace	3
4. Laser Interferometry	4
5. Conclusion	5