

REPORT DOCUMENTATION PAGE			Form Approved OMB No. 0704-0188	
Public reporting burden for this collection of information is estimated to average 1 hour per response, including the time for reviewing instructions, searching existing data sources, gathering and maintaining the data needed, and completing and reviewing the collection of information. Send comments regarding this burden estimate or any other aspect of this collection of information, including suggestions for reducing this burden, to Washington Headquarters Services, Directorate for Information Operations and Reports, 1215 Jefferson Davis Highway, Suite 1204, Arlington, VA 22202-4302, and to the Office of Management and Budget, Paperwork Reduction Project (0704-0188), Washington, DC 20503.				
1. AGENCY USE ONLY (Leave blank)		2. REPORT DATE March 22, 1997	3. REPORT TYPE AND DATES COVERED Final Technical Report 15 Aug 95 to 14 Aug 96	
4. TITLE AND SUBTITLE Instrumentation for High Temperature Testing of Advanced Materials			5. FUNDING NUMBERS F49620-95-1-0506	
6. AUTHOR(S) Professor Horacio Dante Espinosa			AFOSR-TR-97	
7. PERFORMING ORGANIZATION NAME(S) AND ADDRESS(ES) School of Aeronautics & Astronautics Purdue University West Lafayette, IN 47907-1282			0549 REPORT NUMBER	
9. SPONSORING/MONITORING AGENCY NAME(S) AND ADDRESS(ES) AFOSR/NA 110 Duncan Avenue, Rm B115 Bolling AFB, DC 20332-8050			10. SPONSORING/MONITORING AGENCY REPORT NUMBER F49620-95-1-0506	
11. SUPPLEMENTARY NOTES			19971103 062	
12a. DISTRIBUTION AVAILABILITY STATEMENT Approved for Public Release; Distribution Unlimited.			12b. DISTRIBUTION CODE	
13. ABSTRACT (Maximum 200 words) Our research consists of performing plate impact and rod impact experiments designed for <i>specimen recovery</i> . Impact experiments offer several advantages over more traditional quasi-static experiments. In impact experiments, the magnitude and duration of stress pulses can be selected so that the inelastic and/or damage event is stable, and its evolution can be monitored under well defined deformation histories. As a result, damage initiation and evolution rather than simply final accumulated damage can be identified. the main objective of this research is the correlation between the observed damage or inelastic mechanisms and monitored velocity histories at room and high temperature. the correlation is accomplished by performing numerical simulations of the experiments with inelastic models accounting for the observed failure mechanisms. the research methodology will be extended to study material mechanical properties at elevated temperatures. Specific research topics to be addressed are: 1) inelasticity and damage in nanophase ceramics, 2) mechanics of friction and wear of coatings, and 3) dynamic inelasticity in fiber reinforced composites.				
14. SUBJECT TERMS			15. NUMBER OF PAGES 7	
			16. PRICE CODE	
17. SECURITY CLASSIFICATION OF REPORT Unclassified	18. SECURITY CLASSIFICATION OF THIS PAGE Unclassified	19. SECURITY CLASSIFICATION OF ABSTRACT Unclassified	20. LIMITATION OF ABSTRACT UL	

**INSTRUMENTATION FOR HIGH TEMPERATURE TESTING
OF ADVANCED MATERIALS**

FINAL PROGRESS REPORT

HORACIO DANTE ESPINOSA

March 22, 1997

AIR FORCE OFFICE OF SCIENTIFIC RESEARCH

CONTRACT NUMBER: F49620-95-1-0506



SCHOOL OF AERONAUTICS AND ASTRONAUTICS

West Lafayette, IN 47907-1282

APPROVED FOR PUBLIC RELEASE; DISTRIBUTION UNLIMITED

TABLE OF CONTENTS

1. INTRODUCTION	3
2. EQUIPMENT ACQUISITION	4
3. PARTICIPATING PERSONNEL	4
4. WORK PERFORMED UNDER THIS GRANT	4
5. FUTURE WORK	7

1. INTRODUCTION

Our research consists of performing plate impact and rod impact experiments designed for *specimen recovery*. Impact experiments offer several advantages over more traditional quasi-static experiments. In impact experiments, the magnitude and duration of stress pulses can be selected so that the inelastic and/or damage event is stable, and its evolution can be monitored under well defined deformation histories. As a result, damage initiation and evolution rather than simply final accumulated damage can be identified. The main objective of this research is the correlation between the observed damage or inelastic mechanisms and monitored velocity histories at room and high temperature. The correlation is accomplished by performing numerical simulations of the experiments with inelastic models accounting for the observed failure mechanisms. The research methodology will be extended to study material mechanical properties at elevated temperatures. Specific research topics to be addressed are: 1) inelasticity and damage in nanophase ceramics, 2) mechanics of friction and wear of coatings, and 3) dynamic inelasticity in fiber reinforced composites.

In order to perform dynamic experiments at high temperature, an induction heating unit was purchased from Lepel Co. to simulate the high temperatures present in aircraft engines, thermal-barriers and wear-resistant coatings. Temperature effects are of particular relevance in understanding shear localization and dynamic friction properties, because significant increases of temperature are the result of continuous interfacial sliding. Future research with the newly developed capability will provide the necessary information for the formulation of constitutive laws that can properly model bulk material behavior at high temperature as well as the frictional behavior of interfaces composed of different materials. Fundamental understanding of the role of plasticity (in ductile materials), and microcracking (in brittle materials) is expected to be gained. These findings will enhance the design of engine components, and wear-resistant coatings in bearings and turbomachinery.

2. EQUIPMENT ACQUISITION

The following equipment was acquired under this grant.

- 1) Model LSP 12 25-30, 100% solid state power supply \$ 41,450.00
- 2) Sun Ultra Sparc 2, C Model 2170 with Two 167MHZ UltraSparc-1 Processors,
A14-UBA2-IE-064AB and Accessories \$ 19,089.00
- 3) Sun Sparc 20, 20" Color Monitor, Turbo-GX 1-Mbyte Frame Buffer, 64 Mbyte,
1.05-Gbyte Internal Fast SCSI-2 Disk \$ 15,177.00
- 4) Oscilloscope LeCroy #9384L \$10,546

3. PARTICIPATING PERSONNEL

One post-doc, Dr. G. Yuan, and one graduate student, Yueping Xu, participated in this project. They help to design and install the induction heating system acquired from Lepel which allow to heat conductive and non-conductive materials up to high temperatures within a short time. They also prepared blue prints and supervised the manufacturing of a specially designed target holder, coil and shield to allow specimen heating prior to dynamic impact testing.

4. WORK PERFORMED UNDER THIS GRANT

4.1 Evaluate available equipment and identify potential problems

To perform high temperature dynamic tests, several issues need to be addressed. How to measure sample temperature within a magnetic field? How to design the target such that heat can be transferred to non-conductive materials, i.e., ceramics? How to keep the alignment between the impactor and target during heating? To answer these questions, careful investigation was carried on in order to set up impact experiments which could be performed at temperatures up to 1400°C successfully.

4.2 Solutions

On the basis of theoretical analysis and experimental results carried out by Lepel Co., Model LSP 12 25-30, 100% solid state power supply had been selected to meet our requirements. This power supply has the following standards features:

- Operates at 480 Volts, Three phase, 60 HZ Line Current.

- Totally enclosed Nema 12 cabinet construction.
- Input power required at full output power is 31 kVA.
- Conversion efficiency is approximately 90%.
- Output power is 25 kW at 30 kHz.
- Requires cooling water at 30 PSI differential minimum, 95° F maximum at 7 GPM.
- Variable ratio output transformer for load impedance matching.
- Internal multi-tap load matching capacitors allow full power operation over a wide range of coil load conditions.

To perform high temperature impact tests, we designed a special target holder as shown in Figs. 1 and 2. Since one of our objectives is to test ceramic materials, which are non-conductive materials, it was necessary to use a conductive susceptor to heat the specimen. In our application, graphite was selected as a susceptor because it has the same thermal coefficient of expansion of ceramic materials and good thermal conductivity. To avoid melting the coil, the refractory material KAOWOOL HS-45 manufactured by Thermal Ceramics was selected as a protective sleeve. The thickness of the insulating sleeve between the induction load and the graphite susceptor was 1/2". To prevent heating the target holder steel rings, close to the outside coil, a specially designed shield, water cooled, was adopted. A vacuum feed through, not shown in the figures, was designed to transport 1000V and high current to the coil. Flexible lead fittings connecting the load coil to the feed through were used within the vacuum chamber.

Recent experimental results showed that the design of entire system can meet our requirements. According to standard testing procedures, an alumina ceramic sample can reach a glowing red temperature in 20 secs at 75% power.

5. FUTURE WORK

High temperature impact experiments will be performed in our 3.0-inch gas gun. Non-contact laser interferometric measurement will be used to monitor the normal and transverse velocities at the target free surface. It is known that interferometric measurements at high temperature have been successfully utilized in the past; hence, no difficulties are anticipated. The target rear surface will be polished and a special grating will be made

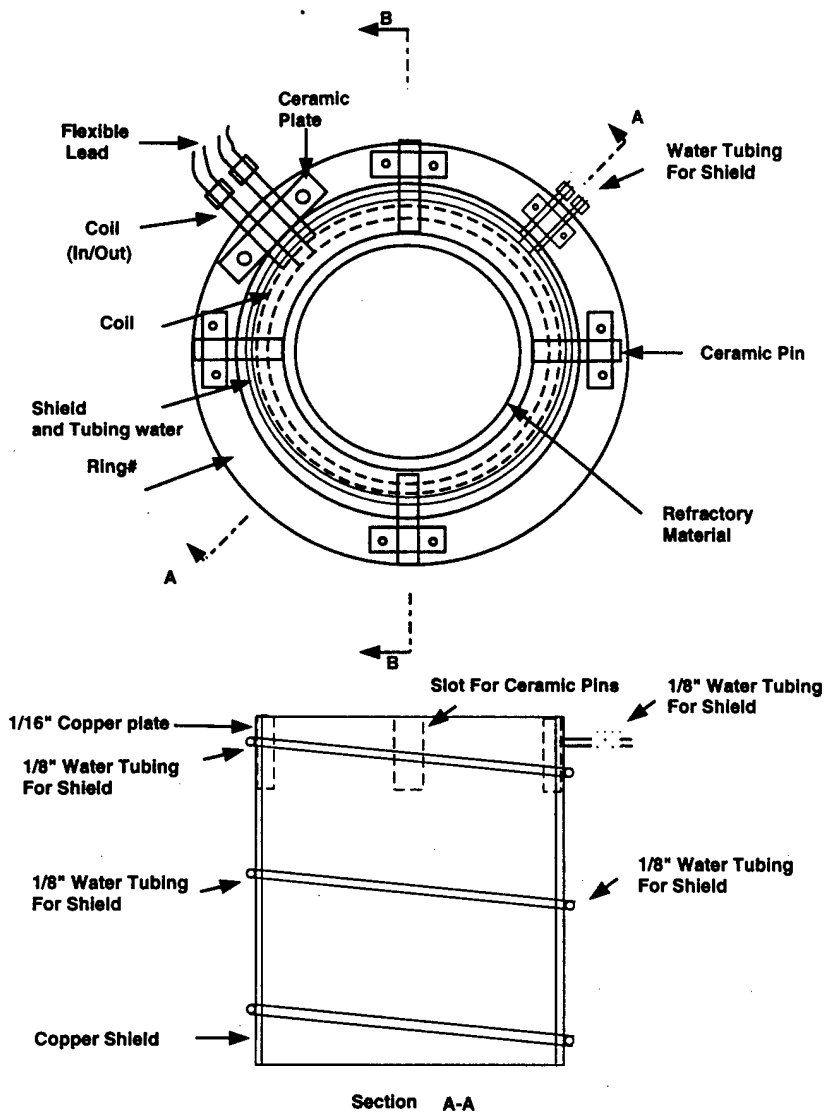

Fig. 1: Schematic of target holder-section A-A.

which can be subjected to a high temperature field. After mounting the target plate in a holder ring, it will be aligned to the impactor surface within 0.5 milliradians using an optical technique. A reference laser beam reflected from the target will be used to adjust the misalignment during sample heating to preserved parallelism. This technique can be employed for both bar and plate experiment.

To measure the sample temperature, two different methods are under consideration. One is contact measurement by means of a thermocouple, another is noncontact measure-

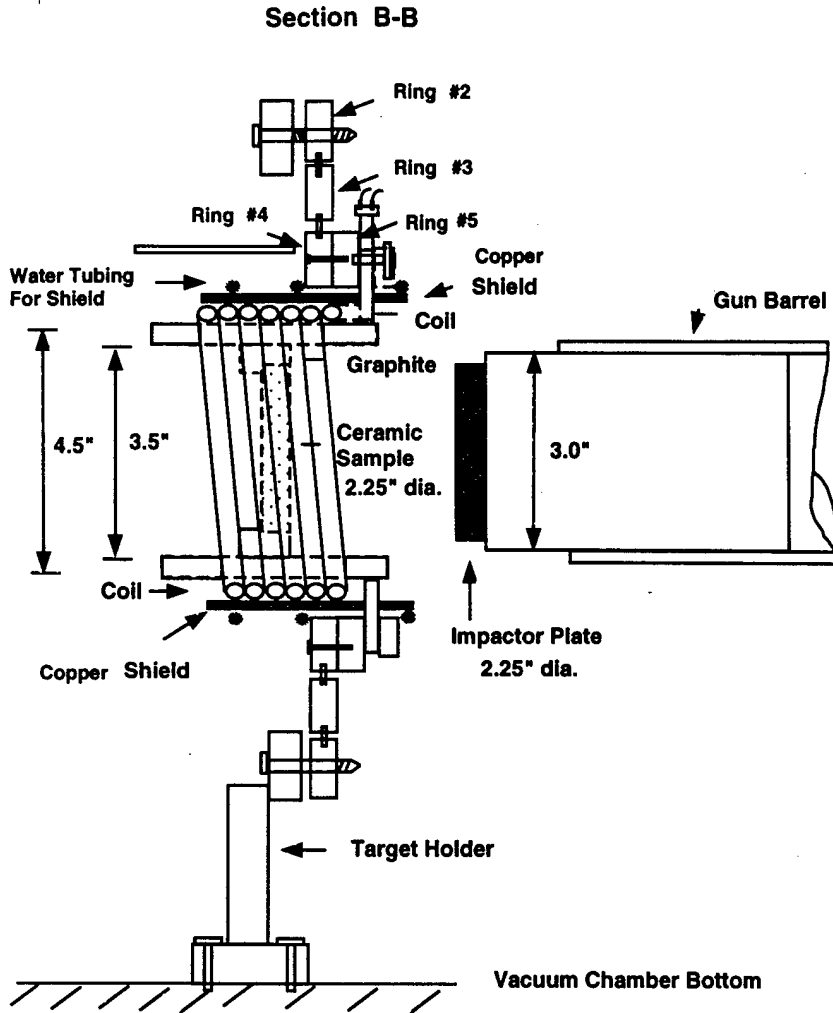

Fig. 2: Schematic of target holder-section B-B.

ment by infrared thermometry. In both cases, a controller will be used to hold the sample temperature at a predetermined value. Although the thermocouple method is cheaper, it is easy to be influenced by the magnetic field generated by the coil and output a temperature with a certain extent of error. We are planning to test both methods at the beginning.