

Report of

MANUFACTURE OF ARCTIC CAPABLE
LOW FREQUENCY ACOUSTIC SOURCE

Advanced Science & Technology Centre

Arlelnyi, V.V.
Bogoluibov, B.N.
Dubovoi, Yu.A.
Pigalov, K.E.
Ubenkov, L.A.
Slavinsky, M.M.
Zharov, A.I.

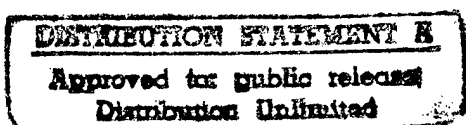

Subcontract Number 31-950004-94

September 1995

DTIC QUALITY INSPECTED 8

19971030 078

Contents

1. Radiator Construction
2. Calculation of Source Parameters
3. System of Hydrostatic Pressure Compensation
4. Results of Source Tests
5. Conclusions

References

1. Application No. 93-058049/10(057991) of December 25, 1993.
2. Bogolubov B.N., Slavinsky M.M. et al. "Design Study of Arctic Capable Low Frequency Acoustic Source", Technical Report, Advanced Scientific and Technology Centre, Nizhny Novgorod, Russia, 1993.
3. F. Morz. Oscillation and sound. Gostechizdat, 1949.

1. Radiator Construction

The view of the radiator in section is shown in figure 1. The radiator is a monopole with a radiating surface in the form of two symmetrically placed pistons 1. The operation regime of the radiator is the reciprocating oscillations of the pistons varying the radiator volume and providing thereby the sound radiation into water. The resonance frequency of the radiator is determined, on the one hand, by the attached mass of water and by the mass of the oscillating parts of the radiator and, on the other hand, by the total elasticity of the disk springs 2, the elasticity of the decoupler of the piston and the case, as well as by the air elasticity inside the radiator. The radiator oscillations are produced by the ponderomotive attractive force occurred between the poles of the mobile parts 3 and the immobile part 4 of the electromagnet when currents runs in the winding 5.

The emitting elements of the radiator are the same and their view is shown in figure 2. Each emitting element is made of one-piece D16T aluminum and has the piston 1, the flange 2 and the decoupler 3. The diameter of the emitting element is 1400 mm and is chosen proceeding from the maximum admissible sizes of the radiator. The maximum admissible size of the radiator was limited by the dimensions of the loading door of the aircraft to be used for the Arctic experiment. The thickness of the piston is chosen such that its strain caused mainly by the inertial loads is much less than its oscillation amplitude. The piston diameter is 1000 mm, it is connected to the central part of the disk springs over the support surface of the diameter 300 mm. The flange is used to connect the emitting element to the flanges of the disk springs. The decoupler is the sylphon, its sizes are chosen proceeding from the fact that the mechanical loads occurred in it due to oscillations should not exceed the admissible loads and the decoupler elasticity is to be essentially less than that of the disk springs.

The disk springs are the basic elements which determine the elasticity and the operating frequency of the radiator. In this mechanical oscillating system the stiffness for

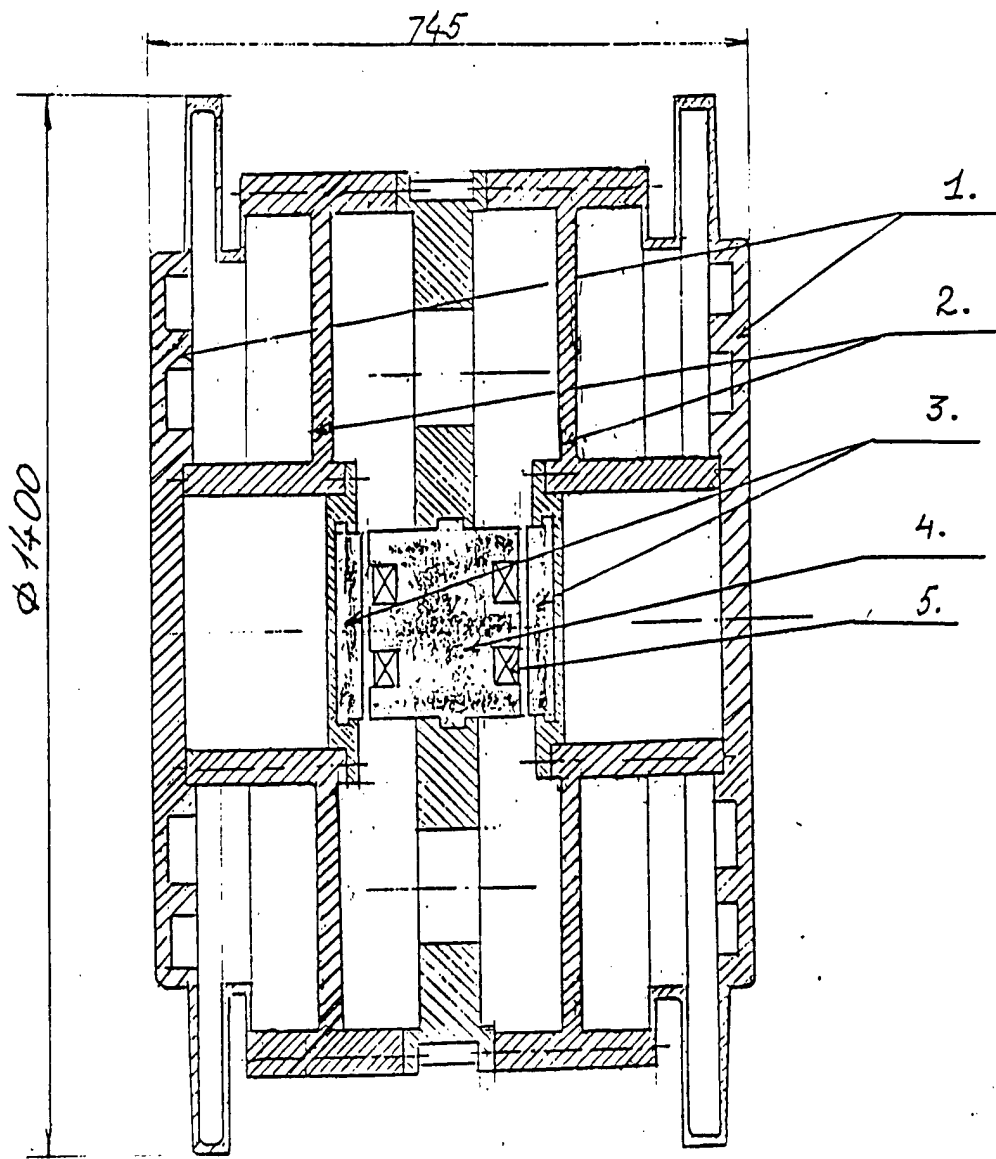

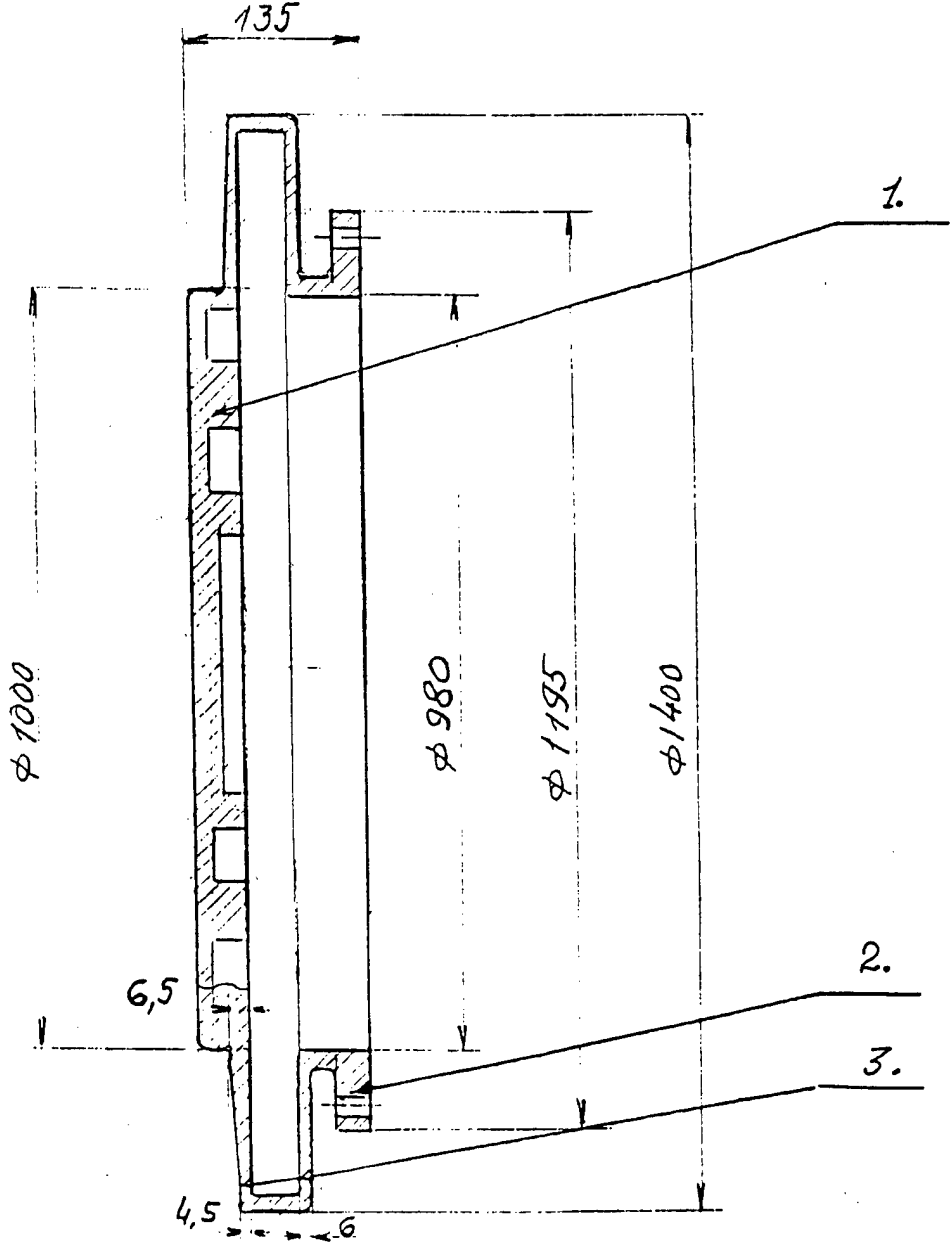

the reciprocating (operating) piston oscillations and for its axially nonsymmetric (parasitic) oscillations are different, which permits to separate the frequencies of the lower operating oscillation modes of the radiator and its other modes. The oscillation system performs stable operating oscillations at rather large levels of the radiated power in spite of always present nonsymmetry and inharmonicity of the exciting force and of the nonlinearity of the oscillating system leading to the occurrence of strong parasitic vibrations of the radiator in the known constructions when a definite, usually low threshold of the radiation power is achieved. The disk springs are made of the same D16T alloy as the emitting element.

The electromagnetic system of the radiator shown in figure 3 has two mobile 1, one immobile 2 parts of the magnetic circuit and two windings 3 connected in series. All the parts of the magnetic circuit are made of the E-310 electrical sheet steel with maximum saturation induction 1.7 T. The magnetic circuit cross-section is equal to 0.011 m^2 , which enables one to obtain the amplitude of the variable component of the exciting force for each piston of the order of 1000 N. The immobile part of the magnetic circuit is rigidly fixed in the case. The gap between the mobile and immobile parts of the magnetic circuit is equal to 8 mm.

The emitting elements, the disk springs and the case are connected coaxially according to figure 1 and are bound with bolted joints through the external flanges. The water-tightness of the construction is provided by the rubber seal rings enclosed in the flanges. The internal flange of each pair of the disk springs is rigidly connected with the bolted joints to the corresponding pistons and to the mobile parts of the magnetic circuit. All the air compartments inside the radiator are connected using the pilot holes. The radiator has an electrical lead-in for connecting the KVD60-4x1.5 cable with the longitudinal water-tightness, an air lead-in for switching on the compensation systems of the hydrostatic pressure. To prevent the radiator failure and to simplify the ascending and descending operations, it is provided with the pressure relief valve limiting the excess internal air pressure of 0.25 atm. in the radiator. To decrease the aluminum corrosion in the radiator, all the contact places of the aluminum and steel fasteners are electrically insulated. The external surface of the radiator assembly are covered with two layers of paint.

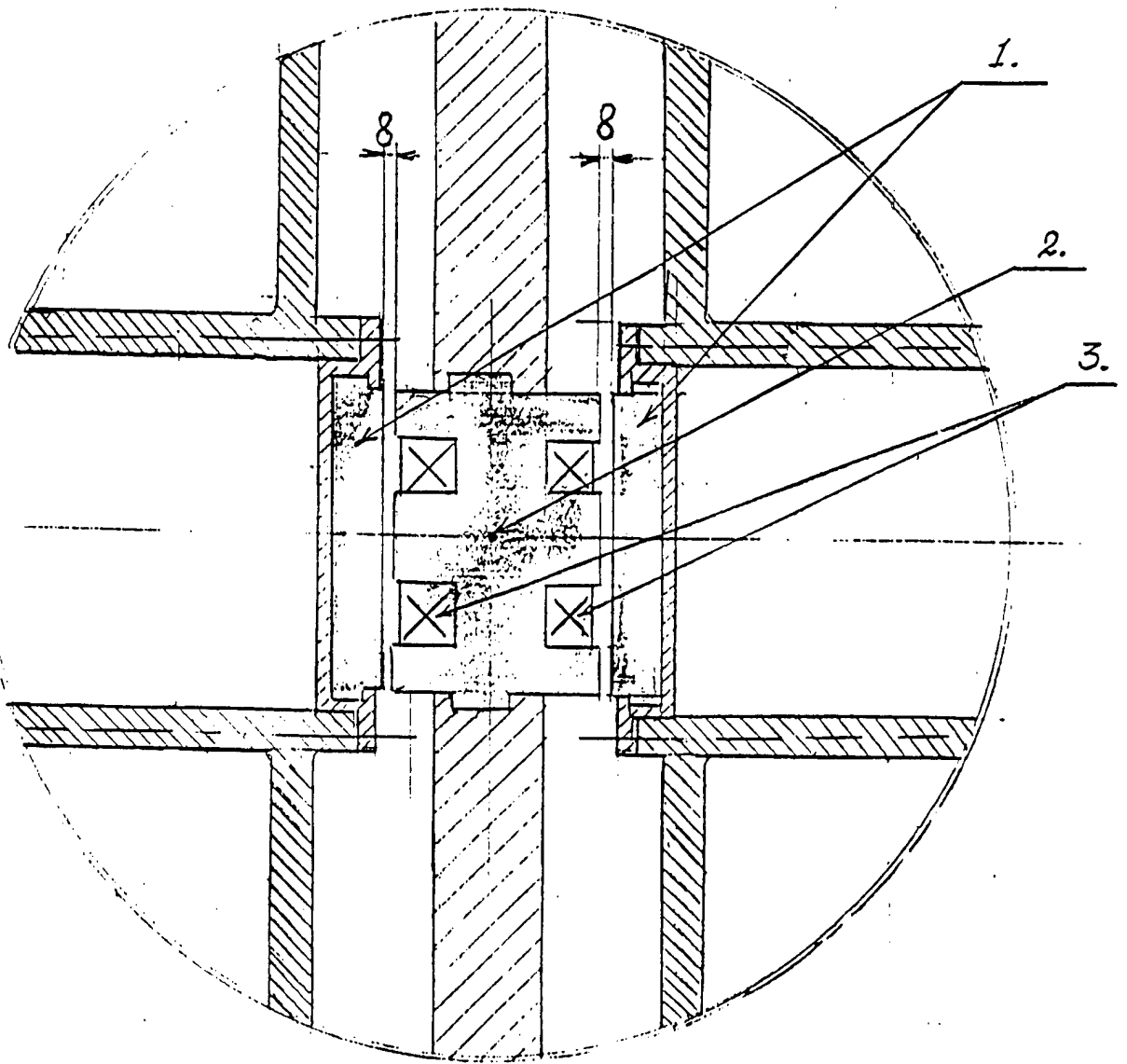

2. Calculation of Source Parameters

Since the source pistons are arranged symmetrically, there is a plane of symmetry on which the normal projections of the speed of displacements of the medium are equal to zero. In this case, for the calculation of the added mass one can use the expression for a round piston in an infinite rigid screen [3]

$$m_a = \frac{8}{3}\rho r^3 \quad (1)$$

where m_a is the addition to one piston of water mass, ρ is the water density, and r is the piston radius. The radiating element consists of a piston and sylinder, and the productivity of the sylinder per unit area is two times less than proportionate productivity of the piston. From this it follows that the radius of an equivalent piston is equal to the mean square of the radii of the piston and sylinder. In our case, $r=0.608$ m, therefore $m_a=600$ kg. The equivalent co-vibrating mass of the source elements is $m_c=130$ kg, and the full vibrating mass on one piston is equal to 730 kg.

The equivalent area of the radiating area of a source is $S_e=2\pi r^2=2.32$ m². The radiated power of a monopole is defined by the expression

$$N = \frac{\rho\omega^4 S_e^2 \delta^2}{8\pi C} \quad (2)$$

where ω is the angular frequency of oscillation, δ is the amplitude of piston oscillation, and C is the sound speed in water. Using Equation (2), we define the motion of the piston for which at a frequency of 20 Hz the radiation level is equal to 201 dB, which corresponds to 1 kW of radiated power, $\delta=5.2$ mm. The gap ?? in the magnetic conductor must lie within the limits of 1.5-2 from δ . In the present construction, the clearance is chosen to equal 8 mm. Knowing the area of the radiating surface, it is easy to find the radius of an equivalent radiating sphere, $r_e=(S_e/4\pi)^{1/2}=0.45$ m. If m_a is much bigger than m_w , then the relative frequency bandwidth of the source is related to r_e through the expression

$$\delta f = \frac{\omega r_e}{C \gamma} \quad (3)$$

where γ is the mechanical-acoustical efficiency of the source. In turn, γ can be defined by the empirical formula

$$\gamma = 1 - \frac{f_w Q_w}{f_a Q_a} \quad (4)$$

where f_w and Q_w are the resonance frequency and quality function of the source in water, and f_a and Q_a are the resonance frequency and quality function of the source in air. Using the results of laboratory and half-natural experiments, it is determined that γ lies in the range 0.6-0.7. Then from expression (3) we find that δf is approximately equal to 0.06. The magnetic system of the source is intended for working in a frequency band three times wider than the mechanical oscillation system of the source. As a result the expected bandwidth of

the source is equal to 3 Hz.

The relation between the power radiated at resonance frequency and parameters of the magnetic system is defined by the expression

$$N = \frac{\pi C B^4 S_m^2}{2 \mu_0^2 \rho \omega^2 S_e^2} \nu, \quad (5)$$

where B is the induction in the gap of the magnetic conductor, μ_0 is the magnetic permeability, S_m is the section area of the magnetic conductor, ν is the electro-acoustic efficiency of the source. From (5), for $N=1000$ W we find that $S_e=0.002$ m². As discussed in Chapter 2, in the present construction the section area of the magnetic conductor $S_m=0.011$ m², which provides a broadening of the source frequency band by a factor of three, in comparison with the frequency band of its own mechanical oscillation system. At a radiated power of 1000 W, the current in the coil of the magnetic conductor is equal to 6.5 A, and at the edge of the frequency band is equal to 11 A. The ohmic resistance of the coil of the electromagnet is equal to 4.4 Ω , and since at a frequency of 20 Hz the electrical losses lead to a primarily resistive character, we find that the electromechanical efficiency of the source is equal to 84% and 65%, respectively. The total efficiency of the source is equal to 50% and 38%, respectively. Inductance of the magnetic system is 0.55 H, and the nominal input voltage is 450 V and 750 V, respectively.

The calculation and optimization of the elastic elements of the mechanical oscillation system of the source, the determination of the mechanical load and the characteristic frequencies are produced with the help of a special program. Certain calculation results are shown below.

The elastic decoupler of the radiating element, Fig. 2, has the following parameters: thickness of the external edge is 4 mm, the thickness at the place of joining with the piston is 6 mm, the maximum value of a mechanical load for 1 kW power is 8.3×10^7 Pa, the rigidity is 2.2×10^6 Nt/m.

The parameters of the plate springs: the external diameter of the working area (of the membrane) is 1125 mm, the thickness of the membrane along its external diameter is 6 mm, the internal diameter of the membrane is 336 mm, the thickness is 12 mm, the maximum mechanical load under 1 kW power is 9.36×10^7 , the general coefficient of rigidity of the two membranes is 6.74×10^6 Nt/m.

The rigidity coefficient, determined in air in the internal cavity of the source, is given by the expression

$$K_a = \frac{\chi P S_e^2}{V}, \quad (6)$$

where χ is the polytropic index, P is the pressure at the depth of the source, and V is the volume of air inside the source. At the depth of 100 the calculated value of K_a , in calculating on one piston, is equal to 7.5×10^6 Nt/m. Knowing the mass and the total coefficient of rigidity, we find that the expected resonance frequency of the source at a depth of 100 m is equal to 25 Hz. In the real construction the internal volume is separated into several

compartments, formed by parts of the source (see Fig. 1). And although all the compartments are connected by engineering holes, dynamically they can be isolated. Therefore the real contribution of the air would be greater, though its theoretical computation is complicated.

3. System of Hydrostatic Pressure Compensation

In the considered construction of the radiator the difference between the air pressure inside the radiator and the hydrostatic pressure of water outside, which is sufficient for its functioning is 0.2 atm. The functional diagram of the hydrostatic pressure compensation system is shown in figure 4. Its submerged part has two passive compensators of hydrostatic pressure 1 of the total capacity 0.034 m^3 , two check valves 2, the relief valve 3 connecting copper tubes 4. The submerged part is connected to the above-water part of the system by the rubber air hose 5 with a diameter of the hole 9 mm. The above-water part consists of the high-pressure cylinder 6 of a capacity 40 dm^3 , the valve 7, the high pressure manometer 8, the pressure regulator 9 which reduces the pressure. The standard cylinder contains 6 m^3 (normal) of air enabling one to submerge the radiator to a depth of 100 m.

The submerging method is as follows:

1. The radiator inductance is preliminarily measured at the excess pressure of 0.25 atm determined by means of the relief valve, the inductance is measured at the negative pressure of 0.3 atm. by submerging the radiator to a depth of 3 m.

2. The pressure not higher than 12 atm. is set by using the pressure regulator and the manometer.

3. The radiator is lowered in water to a depth of 1.5-3 m and the valve is opened. The radiator filling with air is controlled by continuous measuring its inductance. When the inductance corresponding to 0.25 atm. is achieved, the radiator is submerged to a depth of approximately 6 m until the inductance corresponding to 0.3 atm. is provided.

4. Step by step the radiator is submerged to the necessary depth. At the last step the radiator is submerged to a depth corresponding to the exact compensation of the hydrostatic pressure, which is determined by measuring the inductance.

The passive compensators provide the serviceability of the radiator when it oscillates at a depth of $\pm 3 \text{ m}$.

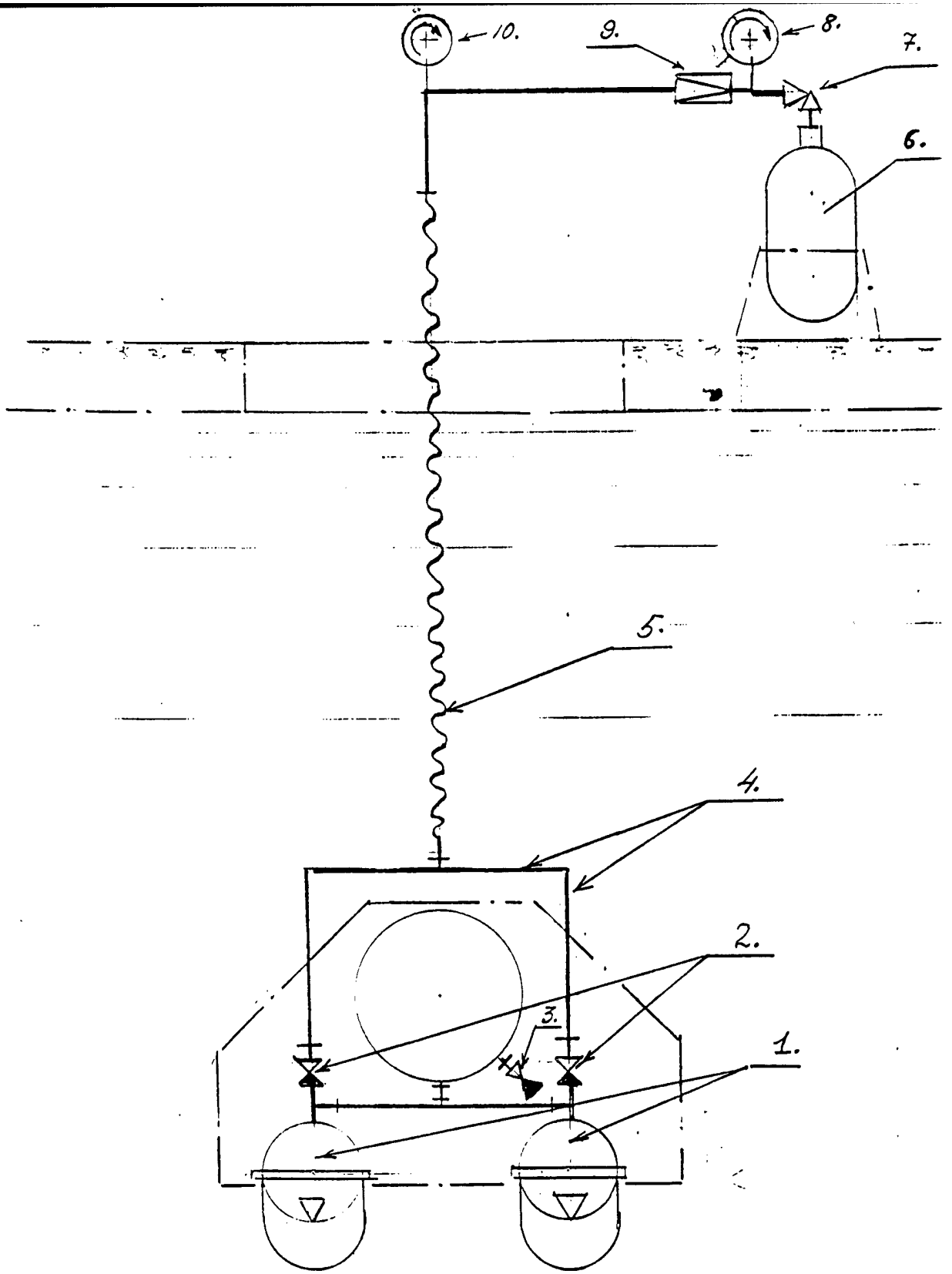

4. Results of Source Tests

The aim of is the determination of electrical and acoustical characteristics of the radiator for its field changes and the resonance frequency fitting.

The laboratory tests were performed using the pilot production on January 4, 1994. the scheme of the laboratory tests is displayed in figure 5. The semifield tests were carried out in the deepening. The depth in the test place was 12 m. The scheme of the semifield tests is shown in figure 6. The symbols used in the figures are: SG is the master oscillator, D is the thyristor driver, E is the electromagnetic hydroacoustic emitter, S is the acceleration sensor, OS is the oscillograph, mV is the millivoltmeter, PCS is the pressure compensation system, and H is the hydrophone.

As a result of the tests the following characteristics were obtained:

- | | |
|--|-----------|
| - inductance of radiator electromagnet | -0.55 Hn |
| - winding resistance | -2.8 Ohm |
| - resonance frequency of radiator in air | -51.8 Hz |
| - mechanical Q-factor of radiator in air | - 100 |
| - resonance frequency of radiator in water
at a depth of 5 m | - 22.8 Hz |
| - resonance frequency of radiator in water
at a depth of 10 m | - 23.3 Hz |
| - frequency band of radiator | - 0.68 Hz |
| - winding current at radiation level 195 dB | - 7.5 A. |

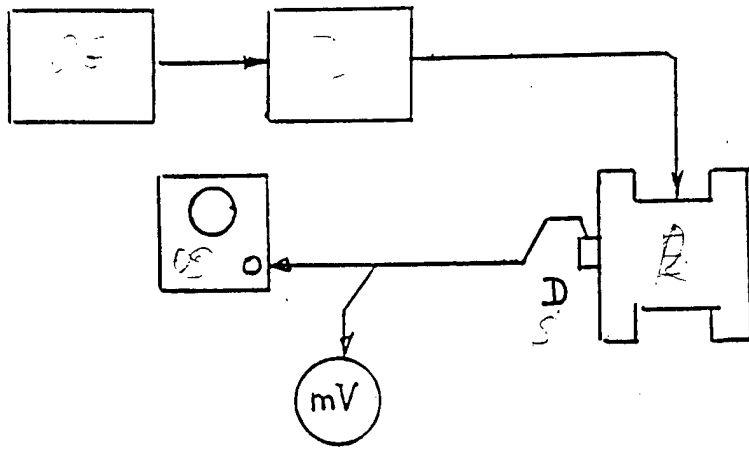

Fig 5

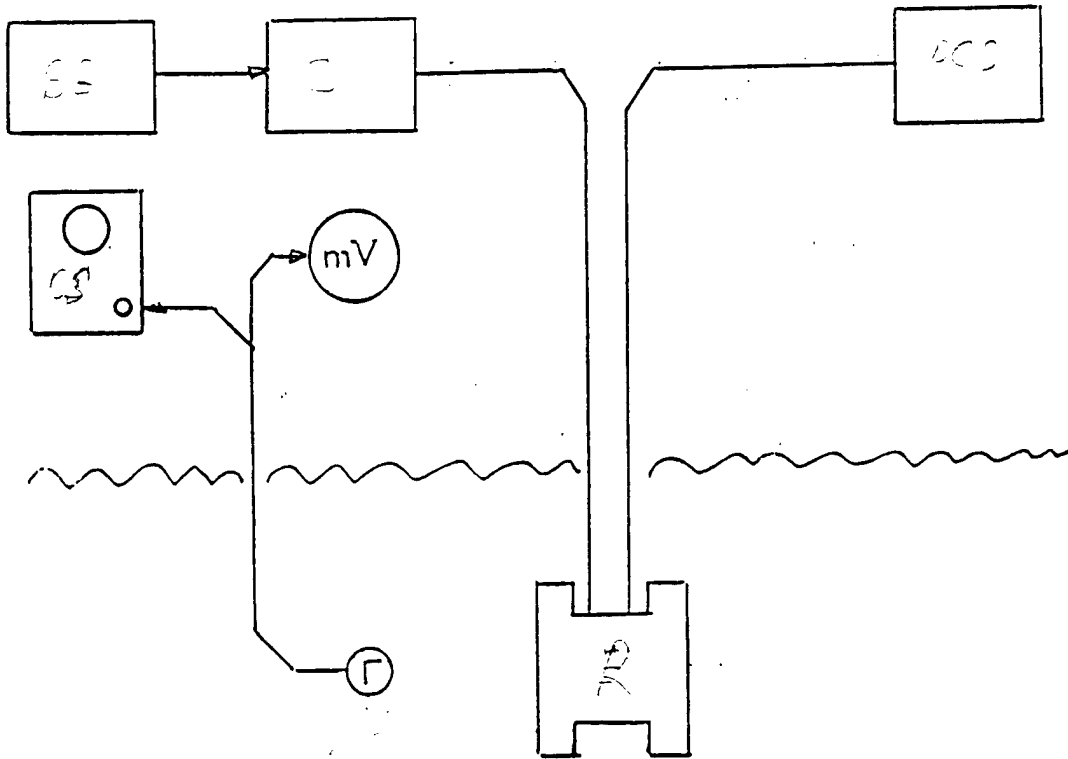

Fig 6

5. Conclusions

The following conclusions can be drawn from the data obtained.

1. The resonance frequency of the radiator varies with depth by 0.1 Hz/m. When the radiator were submerged to a depth of 100 m, its frequency would be 32.2 Hz. rather The fitting of the mechanical oscillation system should be further improved in order to decrease the resonance frequency.

2. Being aware of the resonance frequencies in water and air, it is possible to find the ratio of the attached mass of the radiator m^a to its equivalent oscillating construction mass m_c from the expression

$$m_a/m_c = f_a^2/f_w^2 - 1 \quad (7)$$

where f_a and f_w are the resonance frequencies of the radiator in air and water respectively. The mass ratio found experimentally is 4.2.

3. In order to provide the resonance frequency of the radiator equal to 20 Hz at a depth of 50-100 m, its resonance frequency immediately below the surface should be about 15 Hz. Inverse calculations made by the formula 7 yield that the radiator frequency in air is to be 35 Hz. The obtained results were used for improving the mechanical oscillation system of the radiator.

After tests the radiator was disassembled and the thickness of the elastic part of disk springs was reduced by machining. When the radiator was assembled again, its resonance frequency in air has become equal 36.25 Hz.