



**US Army Corps  
of Engineers**

Waterways Experiment  
Station

Final Report  
CPAR-SL-97-2  
September 1997

---

## **CONSTRUCTION PRODUCTIVITY ADVANCEMENT RESEARCH (CPAR) PROGRAM**

**New Technologies for Improving the Consolidation  
of Concrete**

by

A. Michel Alexander, Richard W. Haskins,  
Al Sari, Parviz Soroushian, Jer-Wen Hsu

Approved For Public Release; Distribution Is Unlimited

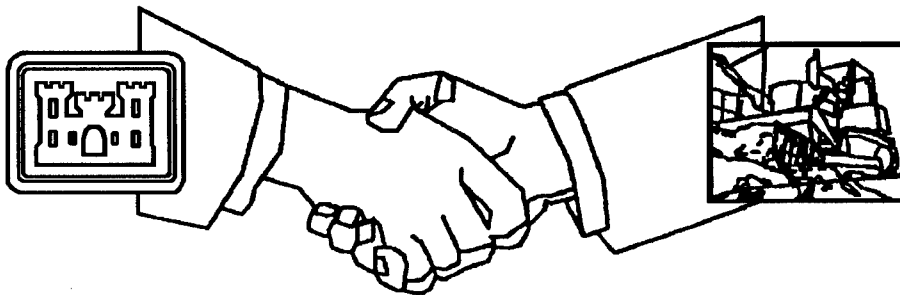

19971117 050

*DMC QUALITY INSURED 4*

**A Corps/Industry Partnership to Advance  
Construction Productivity and Reduce Costs**

The contents of this report are not to be used for advertising, publication, or promotional purposes. Citation of trade names does not constitute an official endorsement or approval of the use of such commercial products.

The findings of this report are not to be construed as an official Department of the Army position, unless so designated by other authorized documents.



PRINTED ON RECYCLED PAPER

**Construction Productivity Advancement  
Research (CPAR) Program**

Technical Report  
CPAR-SL-97-2  
September 1997

# **New Technologies for Improving the Consolidation of Concrete**

by A. Michel Alexander, Richard W. Haskins

U.S. Army Corps of Engineers  
Waterways Experiment Station  
3909 Halls Ferry Road  
Vicksburg, MS 39180-6199

Al Sari, Parviz Soroushian, Jer-Wen Hsu

Innotech International, Inc.  
1232 Mizzen Drive  
Okemos, MI 48864

**Final report**

Approved for public release; distribution is unlimited

Prepared for U.S. Army Corps of Engineers  
Washington, DC 20314-1000



**US Army Corps  
of Engineers  
Waterways Experiment  
Station**

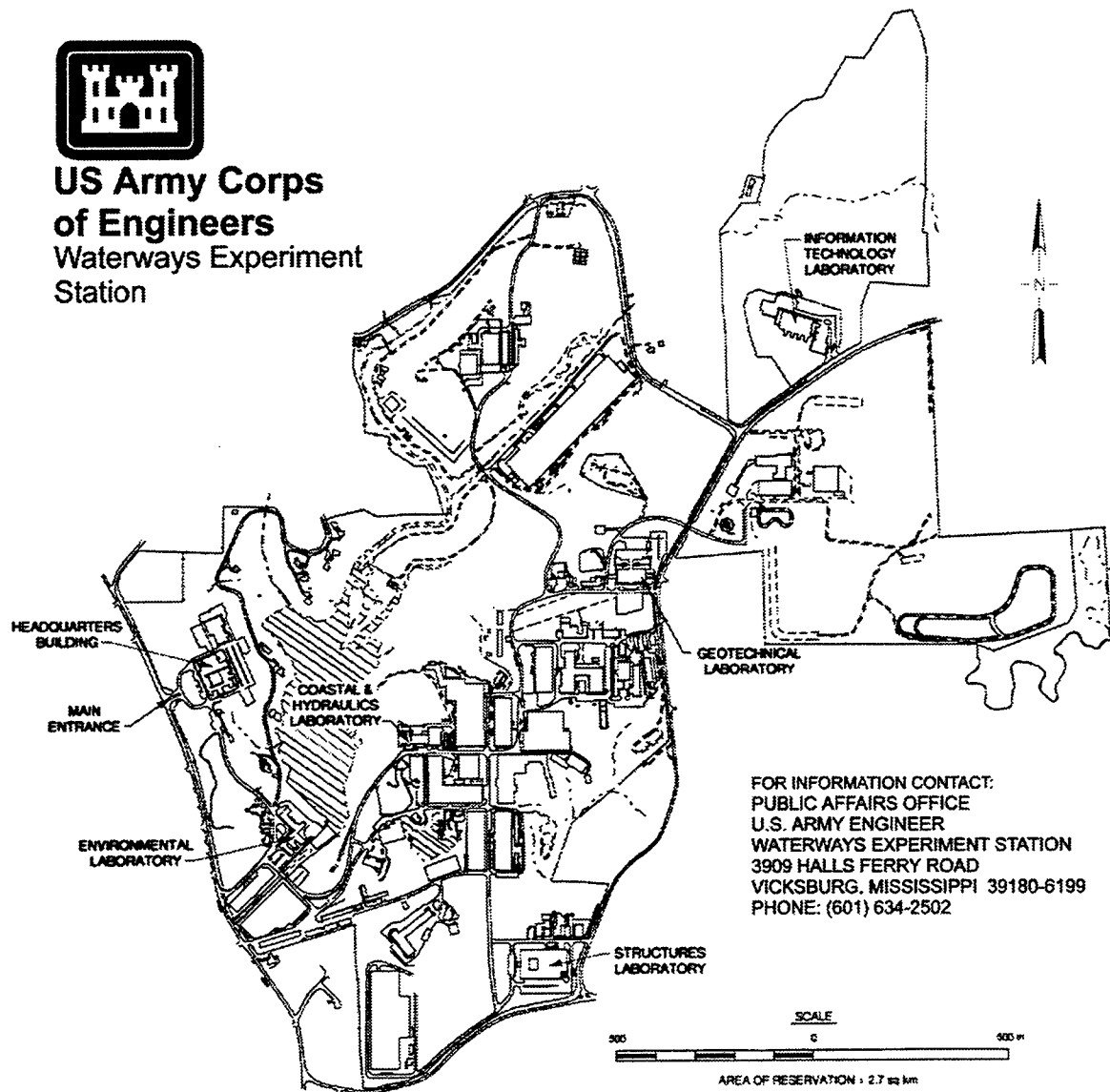

FOR INFORMATION CONTACT:  
PUBLIC AFFAIRS OFFICE  
U.S. ARMY ENGINEER  
WATERWAYS EXPERIMENT STATION  
3909 HALLS FERRY ROAD  
VICKSBURG, MISSISSIPPI 39180-6199  
PHONE: (601) 634-2502

**Waterways Experiment Station Cataloging-in-Publication Data**

New technologies for improving the consolidation of concrete / by A. Michel Alexander ... [et al.]  
; prepared for U.S. Army Corps of Engineers.

101 p. : ill. ; 28 cm. -- (Technical report ; CPAR-SL-97-2)

Includes bibliographical references.

1. Concrete -- Testing. I. Alexander, A. Michel. II. United States. Army. Corps of Engineers.  
III. U.S. Army Engineer Waterways Experiment Station. IV. Structures Laboratory (U.S. Army  
Engineer Waterways Experiment Station) V. Construction Productivity Advancement Research  
Program (U.S.) VI. Series: Technical report (U.S. Army Engineer Waterways Experiment Station)  
; CPAR-SL-97-2.

TA7 W34 no.CPAR-SL-97-2

# Contents

---

Preface .....	vi
1—Introduction .....	1
Background .....	1
Limitations of Present Practice .....	2
Proposed Solution .....	3
Objective from CRDA .....	4
Expanded objective .....	4
Product description .....	4
Improvement of quality control .....	4
Product function .....	5
Scope .....	5
Development .....	5
Contents of report .....	6
2—Development of Resonant Vibrator .....	7
Basic Concepts of Concrete Consolidation .....	7
Description and shortcomings of conventional internal vibrators .....	7
Operation of internal vibrators in slipform pavers .....	8
Basic concepts of new consolidation system .....	8
Objectives of research project .....	8
Analysis and Design of New Consolidation System .....	8
Design objectives .....	8
System design .....	9
Manufacturing and Preliminary Evaluation of the System .....	10
Introduction .....	10
Materials and eccentric forces .....	11
Manufacturing and preliminary evaluation .....	11
Fatigue studies .....	11
Comparative Evaluation .....	12
Evaluation of original prototype system .....	12
Evaluation of final prototype system .....	14
Effectiveness in consolidation of zero-slump concrete .....	15
Monitoring Dynamic Response of RV System .....	15
Basic concepts .....	15
Instrumentation of the resonant vibrator .....	16

Experimental evaluation of the dynamic response	
monitoring system . . . . .	16
Connection Mechanism to Slipform Paver and Final Evaluation . . . . .	16
Introduction . . . . .	16
Connection mechanism . . . . .	17
Evaluation of complete RV with connection mechanism . . . . .	17
3—Development of Consolidation Meter . . . . .	18
Background . . . . .	18
Experimental Work . . . . .	18
MAV measurements . . . . .	19
MWB measurements . . . . .	21
AWB measurements . . . . .	24
AIB measurements . . . . .	27
Design considerations . . . . .	27
Operation of meter . . . . .	29
Packaging of consolidation monitoring instrumentation . . . . .	31
Results . . . . .	31
4—Study of Resonant Vibrator by WES . . . . .	32
Introduction . . . . .	32
Experimental Work . . . . .	32
Test setup . . . . .	32
Laboratory sensors . . . . .	33
Slow hydration . . . . .	33
Analysis . . . . .	33
Results of frequency tests . . . . .	33
Vibration action of new vibrator . . . . .	34
Potential uses of vibrator . . . . .	34
Inability to test CM under dynamic conditions . . . . .	34
5—Conclusions and Recommendations . . . . .	36
Resonant Vibrator . . . . .	36
Achievements . . . . .	36
Technical challenges . . . . .	36
Additional work performed . . . . .	37
Revised structural detailings . . . . .	37
Commercial sensor . . . . .	38
Tachometer needed . . . . .	38
Plans for new shaker . . . . .	38
Consolidation Meter . . . . .	39
Systems Combined . . . . .	41
6—Commercialization and Technology Transfer Plan . . . . .	42
References . . . . .	44
Figures 1-65	

Appendix A: Theory of Impedance Measurements in Concrete . . . . .	A1
Resistivity Measurements and Concrete . . . . .	A1
Path of least resistance . . . . .	A1
Fresh concrete acts as electrolyte . . . . .	A2
Alternating-current (AC) measurements . . . . .	A2
Other Possible Applications . . . . .	A2
Strength detector . . . . .	A2
Consolidation detector . . . . .	A2
Ohm's Law . . . . .	A3
Resistivity . . . . .	A3
Equation describing resistivity . . . . .	A3
Resistivity of various materials . . . . .	A4
Conductors and insulators . . . . .	A4
Ions . . . . .	A5
Polarization . . . . .	A5
Wheatstone Bridge . . . . .	A6
Importance of Wheatstone bridge . . . . .	A6
Configuration of Wheatstone bridge . . . . .	A6
Operation of a Wheatstone bridge . . . . .	A7
Impedance Bridge . . . . .	A9
AC bridge . . . . .	A9
Black box illustration . . . . .	A11
Complex Variables . . . . .	A11
Resistance and reactance . . . . .	A11
Phase relationships . . . . .	A11
Mathematics to describe magnitude and phase . . . . .	A12
Derivation of impedance and phase angle . . . . .	A13
Appendix B: Procedure for Manual Ammeter-Voltmeter (MAV)	
Resistance Measurements and Constant-Volume Mass	
Measurement (CVMM) . . . . .	B1
Testing Potential of Hypothesis Before Refining	
Measurement . . . . .	B1
Preparation of Container and Electrodes . . . . .	B1
Measurement . . . . .	B2
CVMM Technique . . . . .	B2
Static Measurements . . . . .	B3
Conducting Experiment and Recording Data . . . . .	B3
Appendix C: Procedure for Manual Wheatstone Bridge (MWB)	
Resistance Measurements . . . . .	C1
Appendix D: Calculations for Obtaining the Air-Content-Versus-	
Alternating-Current Resistance Curve . . . . .	D1

# Preface

---

This report was prepared at the Structures Laboratory (SL), U.S. Army Engineer Waterways Experiment Station (WES), under the sponsorship of the Headquarters, U.S. Army Corps of Engineers (HQUSACE), as part of the Construction Productivity Advancement Research Program. The investigation reported in this document was conducted under a Cooperative Research and Development Agreement between WES and Innotech International, Inc., Okemos, MI. The HQUSACE Technical Monitors were Messrs. A. Hurlocker, CECW-OC; M. K. Lee, CECW-EG; and G. Hughes, CEMP-ET.

Two products of widely different technologies were developed in this project, although both systems were developed for a common purpose, i.e., advancing the state-of-the-art of consolidation systems for concrete. The investigation for developing the resonant vibrator was performed by Innotech International, Inc., and the investigation for developing the consolidation meter was performed by WES.

The study was conducted under the general supervision of Mr. Bryant Mather, Director, SL, and Dr. Paul F. Mlakar, Sr., Chief, Concrete and Materials Division (CMD), SL. Mr. William F. McCleese, CMD, was the CPAR point-of-contact at WES. Mr. A. Michel Alexander, CMD, was the Principal Investigator of this work unit. Mr. Alexander prepared the report with the assistance of Mr. Richard W. Haskins, Information Technology Laboratory, WES, and Innotech International, Inc., personnel. Messrs. Dan Wilson, Billy D. Neeley, Jim W. Hall III, and Brent J. Lamb, CMD, assisted in the WES laboratory work.

The investigation by Innotech International, Inc., was conducted by Dr. Al Sari, Dr. Parviz Soroushian, and Dr. Jer-Wen Hsu.

At the time of the publication of this report, Dr. Robert W. Whalin was the Director, WES. COL Robin R. Cababa, EN, was the Commander.

*The contents of this report are not to be used for advertising, publication, or promotional purposes. Citation of trade names does not constitute an official endorsement or approval of the use of such commercial products.*

# 1 Introduction

---

## Background

Consolidation of concrete is defined by Ozyildirim (1981) as being “a process through which fresh concrete is densified by removing entrapped air.” Currently most consolidation in the field is performed with mechanical vibrators whose operation is based on a rotating shaft comprising an eccentric weight within a cylindrical metal housing properly supported by bearings at each end of the housing. The rotating shaft can be powered by an electric motor or by hydraulics. The system does not operate at resonance and is therefore highly inefficient as far as the ratio of energy produced to that supplied.

Good consolidation increases strength and abrasion resistance, enhances resistance to freezing and thawing and aggressive fluids, reduces permeability, and improves bond to reinforcement or to hardened concrete (Ozyildirim 1981).

Continuous monitoring of the degree of consolidation can have far reaching consequences in reducing costs and improving quality in concrete structures. Quality improvements are possible by the elimination of entrapped air and related variability in strength due to incomplete consolidation. Improved uniformity can reduce the need for using excess cement to insure meeting strength specification, and thereby save costs. A continuous measure of the degree of consolidation in low slump mixes allows sufficient compaction to be applied to attain adequate consolidation without causing segregation. This in turn allows the use of lower water/cement ratios and the gaining of quality advantages associated with these ratios (Rexnord, Inc. 1978).

Three standard methods of test are used to measure the air content of the fresh concrete as it comes from the mixer. These are the American Society for Testing and Materials (ASTM) C 138 “Standard Test Method for Unit Weight, Yield, and Air Content (Gravimetric) of Concrete”; ASTM C 173 “Standard Test Method for Air Content of Freshly Mixed Concrete by the Volumetric Method”; and ASTM C 231 “Standard Test Method for Air Content of Freshly Mixed Concrete by the Pressure Method” (ASTM 1991). All three methods measure the percentage of air present after however much of the entrapped air has been removed by the specified

consolidation procedures. In addition a fiber optic system has been developed to measure the air content in concrete (Ansari 1990). Another method, ASTM C 457, "Standard Test Method for Microscopical Determination of Parameters of the Air-Void System in Hardened Concrete" (ASTM 1991), is used to measure the air content of hardened concrete.

A nuclear gauge test method, ASTM Designation C 1040, "Standard Test Methods for Density of Unhardened and Hardened Concrete in Place by Nuclear Methods" (ASTM 1991), provides for measurement of the density of the concrete immediately after consolidation. The nuclear gauge operates on the surface of the concrete and is suitable for measurement of the density of concrete to a depth of about 76 mm (3 in.) from the surface.

## Limitations of Present Practice

Currently, the bulk of concrete is consolidated by vibration with poker vibrators. The poker vibrator consists of a rotating eccentric mass that applies radial forces to the vibrator shaft during operation. It is not energy efficient and for that reason has a small radius of action and results in small amplitudes of displacement for the particles and paste. The low amplitude of movement results in mechanical properties that are of less quality than is desirable. Compressive strength, permeability, etc., could be improved with a more efficient vibrator. The poker vibrators are not optimized to perform better at one frequency than another. They operate over a range of frequencies.

There is no real-time quality control on measuring the degree of consolidation of the fresh concrete during the placement process. Visual indication of a glistening surface is not sufficient to ensure the concrete has been properly consolidated well below the surface. The standard procedure for consolidating concrete by vibration is currently very subjective.

The problem with the current ASTM standard methods of test for air content is that they do not necessarily represent the air content of the in-place concrete. The standard methods of test (ASTM C 138, ASTM C 173, and ASTM C 231 (ASTM 1991)) measure the air content of the fresh concrete as it comes from the mixer but not from the placement. It is argued that the air content may not be necessarily representative of the air content of the placement for these methods. None of the three measurement techniques mentioned can make continuous air content measurements during the consolidation process, none can take data automatically, and none can provide results on the in situ concrete.

ASTM C 457, "Test Method for Microscopical Determination of Parameters of the Air-Void System in Hardened Concrete," (ASTM 1991) has the following disadvantages: the results from the test are delayed because the concrete must harden, preventing quality control of the freshly placed concrete; the test is destructive as the core must come from the placement; and the amount of statistics

is not sufficient to make a decision about a large volume placement without taking excessive cores.

In some cases, a nuclear backscatter gauge (ASTM C 1040 (ASTM 1991)) is used to monitor the degree of consolidation behind a slip-form paver for concrete pavement. Disadvantages of the nuclear gauge include the following: a license is required from the Nuclear Regulatory Commission to operate the system due to high-intensity radioactive material used in the system, the system can measure only density and not air content directly, and the nuclear backscatter system can measure only approximately the density of the top 76 mm (3 in.) of the concrete.

Currently, a vibrator operator has little or no feedback on the degree of consolidation of a volume of concrete. A need therefore exists for a means to monitor the degree of consolidation during the time of vibration for both manual poker vibrators and industrial equipment vibrators. Currently, most consolidation by vibration is continued until air bubbles stop rising to the surface and the surface glistens. This current method of allowing the vibrator operator to determine when the concrete is properly consolidated is highly subjective. The surface condition could be misleading as the condition of the surface does not indicate the condition of the concrete well beneath the surface. Also, the radius of action is noted by observation of the surface, and the hand-held poker vibrator operator moves to the next position with some overlap of the previous radius of action. If one vibrates from a lower elevation, then the consolidating process would eventually work its way to the top surface, and the surface would eventually glisten. The problem is that the results are highly dependent on the operator, who cannot be checked or check himself on a location that he may or may not have vibrated. Only the surface can be inspected. Even after the concrete has hardened and the forms have been removed, one can check only the uncovered surfaces and not the interior. In some cases, a pulse-velocity survey can be performed, but that is extra cost and after the fact when the concrete can no longer be reworked.

## Proposed Solution

In response to the need to develop a new improved consolidation system for concrete, a research project was conducted as part of the U.S. Army Corps of Engineers' Construction Productivity Advancement Research (CPAR) Program under a Cooperative Research and Development Agreement (CRDA) between the U.S. Army Engineer Waterways Experiment Station (WES), Vicksburg, MS, and Innotech International, Inc., Okemos, MI. The CPAR Program is a cost-shared research and development partnership between the Corps and the U.S. construction industry, academic institutions, public and private foundations, nonprofit organizations, state and local governments, and other entities who are interested in construction productivity and competitiveness.

Two products of widely different technologies were developed in this project, although both systems were developed for a common purpose, i.e., advancing the state of the art of consolidation systems for concrete. The investigation for developing the resonant vibrator (RV) was performed by Innotech International,

Inc., and the investigation for developing the consolidation meter (CM) was performed by WES.

### **Objective from CRDA**

A new concrete consolidation system was to be developed and commercialized for improving the thoroughness and uniformity of consolidation in the mechanized production of concrete-based infrastructures (canals were targeted for this specific study).

### **Expanded objective**

The objective of this study was to develop a new improved consolidation system for concrete. The system was to be a two-part system, one being an RV and the other being a CM. The RV is defined as a device that is tuned to consolidate concrete efficiently at a specific frequency of operation, and the CM is defined as a device that can detect the presence and amount of air released during the consolidation process. Both products were to be demonstrated in field tests, and both devices were to be commercialized.

### **Product description**

The new concrete consolidation system was to rely on a concrete-vibrator system which produces resonance (maximum motion with least energy input) at frequencies suiting the consolidation of concrete. The system was to be capable of (a) monitoring the degree of consolidation and (b) monitoring and adjusting the frequency and amplitude to obtain the highest efficiency. The system was also to have the potential to combine internal and surface vibrations for achieving optimum efficiency and consistency in concrete consolidation.

### **Improvement of quality control**

Improved construction practices are needed in the United States to help keep America competitive with construction firms in Europe and Japan. The development of a new type of vibrator with improved energy efficiency and a large radius of action would improve the quality of consolidation. Also, the development of a CM to measure the change in air content and provide the results in real-time during the consolidation process would aid in the quality control of freshly placed concrete.

Experiments conducted by Alexander (1977) showed that fresh concrete does not resonate when vibrated at variable frequencies. Alexander recommended that a stiffness element be added to a concrete-vibrator system to create a resonant condition. Maximum motion can be produced with a minimum of energy at

resonance, and a greater radius of action can be achieved with a given input of energy.

Also, for quality-control purposes, it is desirable to measure the degree of consolidation at the stage where the concrete is fresh and in situ, during consolidation or immediately after consolidation.

### **Product function**

The function of the RV was to oscillate at resonance (maximum motion with least-energy input) at a frequency suitable for the consolidation of concrete. The vibrator was to have a larger radius of action than traditional vibrators and operate at a larger amplitude of displacement. The function of the CM was to measure the change in air content during consolidation, which would permit immediate feedback on the degree of consolidation and permit the consolidation parameters to be optimized during placement. The total system was to be capable of improving the consolidation of concrete by the following advancements: an improved vibration field, a new method for monitoring the degree of consolidation, and a means for measuring the frequency and amplitude of the vibrator to obtain the highest efficiency.

## **Scope**

### **Development**

The project development entailed a task to design the new RV analytically by computer simulations from a finite-element mathematical package. Another major task dealt with the effort to determine the geometry of a prototype RV experimentally under the various geometrical constraints of a mechanical paver. Various mechanical properties were tested from concrete consolidated by the new prototype in a simulated field project using a mechanical slipform paver to determine the performance of the RV compared against traditional vibrators. Numerous types of steel were used in building the prototypes to determine which metal best stood up to fatigue.

The main tasks in the development of the CM were to (a) develop a field CM that provided real-time air-content results under the dynamic conditions of consolidation and (b) verify the measurement criteria required to optimize the force and frequency of the RV to get efficient and productive operation. Various secondary tasks included the following efforts: (a) the study of the theory of electrical impedance measurements as it related to fresh concrete, (b) the determination of the feasibility of using the electrical phenomenon for detecting the change in air content during the consolidation process, (c) the testing of the ultrasonic velocity phenomenon should the electrical phenomenon fail, (d) the testing of the range of electrical variables for a variety of concretes that might be used in flatwork construction, (e) the design and construction of a prototype field

device, and (f) various experiments to verify the performance of the prototype CM.

### **Contents of report**

Discussion of the product development of the two-part system is combined in Chapter 1, the Introduction. Documentation of the work describing the development of the RV is confined to Chapter 2. Documentation of the work describing the development of the CM is contained in Chapter 3. Although both consolidation products meet the objective of improving the efficiency of consolidation of concrete during placement, the two products employ widely different technologies. The RV is a mechanical/hydraulic system, and the CM is an electrical system. Since the two systems were developed by two different parties (Innotech, Inc., developed the RV, and WES developed the CM), discussions of the systems are separated in this report to enhance readability. The limited work by WES to study the RV developed by Innotech International, Inc., is described in Chapter 4, and the conclusions and recommendations for both subsystems and the system as a whole are presented in Chapter 5. The commercialization of both subsystems are treated together in Chapter 6. The report is organized in chronological order of the development of each product.

## 2 Development of Resonant Vibrator

---

### Basic Concepts of Concrete Consolidation

Concrete must be properly consolidated to realize its full-strength potential and durability. The consolidation process removes the entrapped air voids, densifies the system, uniformly places large aggregates while retaining the coating of their surfaces with cement paste, and reduces and divides the capillary pores. All of the important properties of concrete tend to improve with proper consolidation.

Concrete consolidation is generally achieved through internal vibration; the compression waves generated by vibrators (Figure 1a) liquify the mortar portion of concrete, thereby reducing the friction and permitting consolidation by gravity forces. Consolidation by vibration is a two-stage process: the first stage consists of vertical settling of concrete, and the second stage involves removal of the entrapped air from mortar (American Concrete Institute (ACI) 1986, 1987; Transportation Research Board 1977; Olsen 1987).

### Description and shortcomings of conventional internal vibrators

Conventional internal vibrators essentially consist of an eccentrically rotated mass (Figure 1b). The operation conditions of these vibrators can be defined by their eccentric mass, eccentricity, frequency of vibration, and exterior diameter.

Some shortcomings of the existing internal vibrators include:

- Inefficient use of vibration energy.
- Nonuniform transfer of forces along their head.
- Nonuniform consolidation of concrete near and away from their path.
- Lack of longevity.

- Lack of real-time capability for monitoring the degree of consolidation.

### **Operation of internal vibrators in slipform pavers**

Internal vibrators operate within a grout box in slipform pavers (Figures 2a through 2e). The grout box is supplied with fresh concrete through an auger, which tries to uniformly spread the concrete transversely. After vibration, the concrete is tamped and then extruded into the final pavement configuration. The vibrator thus practically operates above the final surface layer of concrete pavements. This provides much flexibility in choosing the geometric configuration of new vibrators (see Figure 2f).

### **Basic concepts of new consolidation system**

The new consolidation system relies on structural dynamic concepts to pronounce the vibrating effects of an eccentric mass vibrator. This is achieved by (a) using the resonance phenomenon to efficiently raise the vibratory amplitudes and (b) vibrating a whole steel framework in order to effectively transfer the vibrating effects to large volumes of concrete.

Figure 3 schematically presents the basic concepts of the new consolidation system. An external vibrator produces vibration in the steel framework; the steel framework is designed to exhibit a predominant resonant frequency at 156 Hz, which is appropriate for consolidation of concrete. Resonance efficiently magnifies the vibratory amplitudes of the system, and the large contact surface area of the consolidation system with concrete effectively vibrates a large volume of concrete.

### **Objectives of research project**

Phase I research validated the basic hypotheses on which the new consolidation system was conceptualized. The Phase II research reported herein was concerned with the full development and evaluation of system, design of connection to slipform pavers, and assessment of its longevity under slipform paver operation conditions.

## **Analysis and Design of New Consolidation System**

### **Design objectives**

The consolidation system should satisfy the following requirements:

- Predominant resonant frequency of approximately 150 Hz.

- Large contact areas with concrete.
- Geometric compatibility with the grout box of the slipform paver.
- Compatibility with the modular nature of slipform pavers, which have to offer the flexibility to suit pavements of different widths.
- Long fatigue life.

## System design

The objective of the system design was to satisfy the following requirements: (a) geometric compatibility with the space limitations of the grout box and the modular nature of slipform pavers, and (b) a dominant natural frequency of about 150 Hz. The geometric constraints are satisfied by selecting the general dimensions shown in Figure 4a. A dynamic finite-element analysis of the system was conducted in order to determine vibratory amplitudes at different frequencies. The finite-element model is schematically presented in Figure 4b. Three categories of finite elements are used in this model:

- a. Three-dimensional (3-D) beam elements.
- b. Three-dimensional beam elements with the mass of fluid concrete added to reflect the effects of fresh concrete on dynamic response characteristics of the internally vibrating components.
- c. Mass element.

Two categories of analysis were conducted using the finite-element model of Figure 4b: (a) modal analysis for a preliminary selection of the design parameters to produce resonance in some key components of the system at the targeted frequency of approximately 150 Hz, and (b) dynamic analysis under rotary mass effects for the final selection of the design variables to optimize the use of input energy for the consolidation of concrete.

The key variables in modal analyses for achieving the desired level of natural frequency (~150 Hz) at points A1, A2, B1, and B2 (see Figure 4a) were as follows:

- Cross-sectional diameters.
- Horizontal and vertical lengths.
- Mass at the location of vibratory force application (point C in Figure 4b).

The material used in modal analyses (and throughout the project) was steel with a modulus of elasticity of 210 GPa, specific gravity of 7.86, and Poisson's

ratio of 0.3. A damping ratio of 0.03 was used for the system. The polymer concrete used on the vibrator heads (Figure 4a) had a specific gravity of 2.3.

After the ranges of the geometric attributes of the systems were established for generating the targeted 150-Hz natural frequency, dynamic analyses were performed under the effects of a rotary mass at point C in Figure 4b. A systematic approach based on the statistical concepts of response surface analysis was undertaken to optimize the cross-sectional dimensions and the horizontal and vertical lengths which define the system geometry. In this process, for each specific combination of these geometric variables, the system is subjected to harmonic forces applied at point C (Figure 4b) in the x, y, and z directions. These harmonic forces, which are applied individually, represent the effects of the rotary mass in three principal directions. The vibratory displacement amplitudes of the system at points A1, A2, B1, and B2 in Figure 4b are computed under the effects of these harmonic forces in different directions. The harmonic forces applied in each direction in the dynamic analysis are defined by a frequency and an amplitude (the maximum force value). The frequency is the same as that of the rotary mass, and the force amplitude in direction i ( $F_i$ ) is related to the rotary mass characteristics (see Figure 5) as follows:

$$F_i = 4 \pi f^2 r m \cos(\alpha_i) \quad (1)$$

where

$$\pi = 3.1416$$

$$f = \text{frequency}$$

$$r = \text{eccentricity of mass}$$

$$m = \text{mass}$$

$$\alpha_i = \text{inclination angle of the eccentric mass with respect to the direction of force (i = x, y, or z in Figure 4b)}$$

The final system design resulting from the above dynamic analysis and optimization process is shown in Figure 6. This system exhibits a dominant natural frequency of 156 Hz. The computed vibratory displacement amplitudes of this system under a 6,600-N vibratory force amplitude (applied in y and z directions) are presented in Table 1.

## Manufacturing and Preliminary Evaluation of the System

### Introduction

The analytical studies reported so far yielded the geometric attributes of the system and its optimum operation frequency. Another design consideration is

safety against failure (fatigue failure in this case). Selection of the material and the value of the vibratory force (which depends on eccentricity, mass, and frequency - as introduced earlier) strongly impact the fatigue life of the system. The system was, thus, manufactured with different steels and operated under different vibratory force amplitudes to evaluate its fatigue life.

### Materials and eccentric forces

Innotech International, Inc., built various prototype systems according to the design of Figure 6 using the following types of steel:

- ASAE 410-C-28 with 413-MPa yield strength.
- ASTRALLOY with 965-MPa yield strength and 1,262-MPa ultimate strength.
- Regular cold-rolled A-36 steel with 248-MPa yield strength.

The alternative vibratory force amplitudes considered included: 7,000, 5,000 and 2,500 N.

### Manufacturing and preliminary evaluation

The prototype systems were manufactured using the welding and heat treatment techniques recommended by steel manufacturers. A typical prototype system is presented in Figure 7; the system shown here is fixed on a column for the purpose of laboratory evaluation. The hydraulic vibrator was installed to apply vibratory forces in y and z directions (see Figure 4b).

In order to determine the resonant frequencies of the system, the researchers operated it in air under the effect of 7,000-N vibratory force (applied in y and z directions - Figure 4b) at frequencies gradually increasing to about 160 Hz, and measured the corresponding vertical displacement amplitudes at point A1 in Figure 4b. The results (Figure 8) confirm that the system has a resonant frequency of about 156 Hz.

### Fatigue studies

Exhaustive studies of fatigue life were conducted in concrete and in air with different types of steel and different vibratory force amplitudes. When fatigue failure occurred, vibration in air produced fatigue lives which were only about

Location/Direction (Figure 4b)	Amplitude, mm
A1/	1.3
A1/y	1.3
A1/z	3.4
B1/x	1.3
B1/y	1.3
B1/z	3.4
A2/x	1.3
A2/y	1.3
A2/z	3.4
B2/x	1.3
B2/y	1.3
B2/z	3.4

20 percent of those obtained when vibrating in concrete. The only combination of steel type and vibratory force amplitude which performed satisfactorily in relation to fatigue life involved the use of ASAE 410-C-28 steel (413-MPa yield strength) and 2,500-N vibratory force amplitude. Other systems suffered fatigue failure in concrete after about 20 to 40 hr. An example of fatigue failure is shown in Figure 9.

## Comparative Evaluation

### Evaluation of original prototype system

**Experimental program.** The original prototype system is similar to the one shown in Figure 6 except that the 100-mm-diam polymer concrete head was eliminated and the vibratory force applied in the original system was 7,000 N (in lieu of 2,500 N in the case of the final system). These two differences have opposing effects on the consolidation efficiency of the system. The evaluation of this original system involved test conditions which simulated the slipform paver operation conditions; in this test (Figure 10), the consolidation system moves horizontally with respect to the concrete slab being consolidated. The hydraulic vibrator installed on the system operates at 156-Hz frequency and 7,000-N eccentric force. Three tests were conducted with the prototype consolidation system, and one test with a conventional internal vibrator with a head diameter of 51 mm operating at 200-Hz frequency using a vibratory force of 9,000 N. Both consolidation systems were moved at a horizontal speed of 1.8 m/min against the concrete slab. It should be noted that the conventional vibrator used in this investigation had a higher power than the hydraulic vibrator used to excite the original prototype system.

The concrete mixtures used in this investigation had the following mixture proportions and fresh mixture properties:

- a. 608 kg/m<sup>3</sup> of coarse aggregate (19.0-mm nominal maximum size crushed limestone).
- b. 487 kg/m<sup>3</sup> of fine aggregate (natural sand).
- c. 196 kg/m<sup>3</sup> of Type I portland cement.
- d. 0.489 water-cement ratio (w/c).
- e. 76-mm slump.
- f. 6.7-percent air content.

After consolidation, the concrete slab surfaces were finished using straight edge, bull float, and (after bleeding) float; a curing membrane was subsequently applied on the slabs. At the age of 7 days, a minimum of 16 cores were taken

from each slab (see Figure 11); the researchers attempted to cover all representative areas of the slab by cores. The cores were visually evaluated and were then immersed in lime water to be tested at the age of 10 days.

**Test results.** The cores were subjected to tests on void system characteristics (linear traverse, ASTM C 457), performed on the top, middle, and bottom layers of cores. Compressive-strength tests (ASTM C 39, "Test Method for Compressive Strength of Cylindrical Concrete Specimens") were also performed on the cores.

- a. *Visual observation.* The original prototype system produced cores which, based on visual observation, were consistently well-consolidated with minimum entrapped air content (see Figure 12a). On a subjective scale of 1 to 4 (with 1 representing poor and 4 representing excellent consolidation), more than 96 percent (48 out of 50) of the cores were judged to have a 4 consolidation condition with the new consolidation system. For the concrete slab consolidated with the conventional internal vibrator, however, many cores showed excess entrapped air and honey combing (see Figure 12b). Less than 50 percent of the cores received a consolidation mark of 4; close to 30 percent of the cores were judged to have a 1 consolidation condition, particularly at the bottom of the slab.
- b. *Compressive strength.* The compressive-strength test results from slabs consolidated with the conventional internal vibrator and with the new system (original version) are presented in Table 2. The new system improves the compressive strength of concrete and, more importantly, reduces the variation in test results.

<b>Table 2 Compressive Strength Test Results</b>		
<b>Consolidation System</b>	<b>Compressive Strength</b>	
	<b>Average (MPa)</b>	<b>Std. Dev. (MPa)</b>
Conventional	36	2.5
Original Prototype	45	1.8

- c. *Void system characteristics.* The linear traverse test results are presented in Table 3. The new system is observed to reduce the void content and provide for a more uniform distribution of voids along the height of the concrete slab.

<b>Table 3 Linear Traverse Test Results</b>		
<b>Consolidation System</b>	<b>Air Content (%)</b>	
	<b>Top Layer</b>	<b>Bottom Layer</b>
Conventional	15.0	10.2
Original Prototype	8.4	7.5

## Evaluation of final prototype system

**Experimental program.** The final version of the consolidation system that is the subject of this comparative study is shown in Figure 6. This system was operated using a hydraulic vibrator with 2,500-N vibratory force at a frequency of 156 Hz. The test setup is shown in Figure 10. The internal vibrator used in this comparative study was the same one used before, with a diameter of 51 mm, an eccentric force of 9,000 N, and a frequency of 200 Hz. The speed of the consolidation system, with respect to concrete slab, was 3 m/min. Two slabs were consolidated with a conventional vibrator and two with the final version of the new consolidation system. The slabs were cored 14 days after casting, and the cored samples were subjected to the following tests at 28 days of age:

- Compressive strength (ASTM C 39, "Test Method for Compressive Strength of Cylindrical Concrete Specimens").
- Splitting-tensile strength (ASTM C 496, "Test Method for Splitting Tensile Strength of Cylindrical Concrete Specimens").
- Water absorption, unit weight, and volume of permeable pores at different depths (ASTM C 642, "Test Method for Specific Gravity, Absorption, and Voids in Hardened Concrete").
- Void system characteristics (linear traverse, ASTM C 457, "Test Methods for Microscopical Determination of Parameters of the Air-Void System in Hardened Concrete") at different depths.
- Freezing and thawing durability (ASTM C 666, "Test Method for Resistance of Concrete to Rapid Freezing and Thawing").

**Test results.** Test results are as follows:

- Compressive strength.* As shown in Figure 13, the new concrete consolidation system yields compressive-strength values which exceed those obtained with conventional vibrators by more than 15 percent.
- Splitting-tensile strength.* The new consolidation system also yields improvements in the splitting-tensile strength of concrete (see Figure 14).
- Water absorption.* The water-absorption test results (Figure 15) indicate that the new consolidation system produces more consistency in test results obtained along the center line or on the sides of concrete slabs at different depths. The water-absorption test results for the conventional vibrator, however, vary over a rather broad range, which points at the inhomogeneity of the consolidation level produced by a conventional vibrator.

- d. *Unit weight.* The unit-weight test results (Figure 16) confirm the consolidations made based on the water-absorption test results.
- e. *Volume of permeable pores.* The conclusions derived based on the water-absorption and unit-weight test results regarding the inhomogeneity of consolidation with conventional vibrators are confirmed by the test results on the volume of permeable pores in concrete (Figure 17).
- f. *Void system characteristics.* The results of linear traverse tests are presented in Figures 18 and 19 in the form of air content and air-void spacing, respectively. The characteristics of the entrained air-void system are observed to be improved by the new consolidation system. Improved uniformity of the consolidation levels achieved by the new system could explain this effect.
- g. *Freezing and thawing.* The improved characteristic of the entrained air-void system obtained with the new consolidation system could have positive effects on the resistance of concrete to repeated cycles of freezing and thawing. The freezing-and-thawing test results presented in Figure 20 confirm this.

#### **Effectiveness in consolidation of zero-slump concrete**

The final prototype system and the conventional internal vibrator were used separately to consolidate a zero-slump concrete slab at a speed of 2 m/min. The zero-slump concrete was selected to more clearly show the improvements brought about by the new consolidation system. Cores were taken from the slabs at 7 days of age and tested at 14 days. Figure 21 shows that the conventional vibrator could not consolidate the zero-slump concrete, and excess honeycombing occurred. With the refined system, however, as shown in Figure 22, reasonable levels of consolidation were achieved. Based on the test results on 10 cored samples, the average compressive strength with the conventional internal vibrator and the final version of the new system were 31 and 41 MPa, respectively.

## **Monitoring Dynamic Response of RV System**

### **Basic concepts**

The dynamic response characteristics that were measured with the new strain gauge monitoring system are influenced by the interaction of a solid with its surrounding medium (fresh concrete). This response is thus influenced by the rheological characteristics of the fresh concrete. Since these rheological characteristics vary as concrete consolidates, it was hypothesized that the dynamic response characteristics of the whole system also vary as fresh concrete consolidates. Thus, it should be possible to monitor the dynamic response of consolidating concrete through monitoring a strain-gauged vibrator. A

steady-state response of the system could indicate that concrete has reached its final consolidation condition.

### **Instrumentation of the resonant vibrator**

In order to monitor the dynamic response characteristics of the system, a strain gauge was installed at point A shown in Figure 23. A data acquisition system recorded the strain readings throughout the consolidation process.

### **Experimental evaluation of the dynamic response monitoring system**

With the RV inserted in a mass of concrete at a specific position (Figure 24), the settlement of concrete and the strain gauge readings over time were monitored with the hydraulic vibrator operating at different frequencies. The concrete used in this investigation had a nominal maximum coarse aggregate size of 19.0 mm and a slump of 38 mm. Figures 25a and 25b show the settlement and strain gauge readings versus time at a vibration frequency of 110 Hz. Figure 26 shows similar results at a vibration frequency of 120 Hz. These results confirm that a steady-state reading of the strain gauge marks the completion of the consolidation process.

Figure 8 indicates that this monitoring system detects resonant frequencies at 98 and 156 Hz. The strain gauge readings for the test setup of Figure 24 where the system operates at 96- and 156-Hz frequencies are shown in Figure 27. While the 96-Hz resonant frequency produces larger vibratory displacement amplitudes (see Figure 8), the higher resonant frequency of 156 Hz is observed to consolidate concrete more rapidly.

## **Connection Mechanism to Slipform Paver and Final Evaluation**

### **Introduction**

The prototype system (Figure 6) was designed for incorporation into slipform pavers based on the scheme shown in Figure 2f. The development work conducted so far used a fixed-end connection for the system. In the context of a slipform paver, however, the system requires a connection mechanism capable of moving the RV vertically within the grout box. The whole system, consisting of the connection and the RV apparatus, should also be tested for fatigue life and longevity under realistic operation conditions.

## **Connection mechanism**

The basic concepts of the connection mechanism are schematically presented in Figure 28. This mechanism provides the capability for vertically moving the RV within the grout box. The mechanism as it was finally manufactured is presented in Figure 29. A rigid bar (Figure 30) was used for mounting the mechanism onto the slipform paver. Figure 31 shows the complete connection system consisting of the mechanism and the rigid bar. Figures 32 through 34 show the first complete mounting of the new RV using the connection mechanism introduced here.

## **Evaluation of complete RV with connection mechanism**

A large-scale setup has been designed and manufactured in order to evaluate the fatigue life of the complete RV and connection systems under realistic conditions which simulate the slipform paving operation. This setup (Figure 35) performs all the key functions of slipform pavers; it features:

- A connection/support system for the RV apparatus that can be directly applied to slipform pavers (Figure 36).
- Mechanisms for vertical movement of the RV system, which can also be directly applied to slipform pavers (Figure 37).
- Capability to move horizontally with respect to the placed concrete at variable speeds which cover the ranges commonly used in field applications (Figure 38).
- Hydraulic supply and control systems which are replicas of those used in slipform pavers (Figure 39).

Operation of this system involves placement of concrete (Figure 40), vertically moving the RV down into concrete, and starting the vibrator and the horizontal movement mechanisms (Figure 41). This large-scale setup is used to exhaustively evaluate the longevity and fatigue life of the complete resonant vibrator under realistic operation conditions of slipform pavers. Initial runs with the system have revealed the needs for the following improvements in the hydraulic controls and vibrators for use with the system:

- Refinement of the cooling system of the hydraulic vibrators to withstand long-term operation at a frequency of 156 Hz, which is relatively high for external vibrators.
- Implementation of closed-loop control of the hydraulic system to improve the stability of the actual frequency of vibration by controlling the hydraulic flow and pressure.

# 3 Development of Consolidation Meter

---

## Background

WES had made some electrical impedance measurements on fresh concrete in the past. This experience suggested that electrical impedance measurements can be used to measure the change in air content of concrete during the consolidation process. Air is an insulator, and fresh concrete is a conductor. There is a wide difference between the electrical impedance of an insulator and a conductor. It is logical that the release of the entrapped air during the consolidation process would lower the impedance of the concrete. This is the proposed basis of operation of the consolidation meter (CM). See Appendix A for the theory of impedance measurements in concrete.

## Experimental Work

The experimental effort was conducted in an incremental fashion starting with the simplest of the resistance measurement circuits. The goal was to develop a commercial unit that could measure the change in air content under dynamic conditions of consolidation for the least cost, but that still would have sufficient resolution and accuracy to perform properly. Each description of the circuit that follows progresses from the lower complexity and cost to the higher complexity and cost: an automatic ammeter-voltmeter (AAV), an automatic Wheatstone bridge (AWB), and an automatic impedance bridge (AIB) circuit. For the ultimate goal, an automatic system was necessary for making high-speed measurements under dynamic conditions of consolidation. However, in the initial stages of the project, manual measurements were easier and cheaper to make than automatic measurements, and so the order of initial experimentation in the laboratory proceeded in the following order: manual ammeter-voltmeter (MAV), manual Wheatstone bridge (MWB), and manual impedance bridge (MIB). It was understood from the beginning of the project that the final circuit would be an automatic measurement system since it was desired to measure the change in air

content *during* the consolidation process. Table 4 shows the possible techniques available, and the numbers indicate the actual circuits tested.

Type of Measurement	Ammeter-Voltmeter	Wheatstone Bridge	Impedance Bridge	Status of Vibration
Manual	MAV (1st)	MWB (2nd)	MIB	Static
Automatic	AAV	AWB (3rd)	AIB (4th)	Dynamic

### MAV measurements

**Rudimentary experiment.** As mentioned, the beginning hypothesis for developing a CM was that the electrical impedance (or resistance) of fresh concrete was related to the air content (amount of entrapped and entrained air). The experiments were begun with a simple and inexpensive unpolished AC resistance test called the MAV method (Smith and Wiedenbeck 1959). The MAV method required that the technician make the measurement by hand, so it took several minutes to complete the procedure for making a resistance measurement. It follows that the MAV method can be used only when the motion of the concrete is stationary between short activations of the vibrator.

An MWB AC-resistance measurement would have been as easy to perform and would have given better resolution than the MAV method. However, a final system based on an AWB circuit would cost the end user more than an AAV circuit. If the MAV proved workable, then a commercial AAV system could be manufactured at a lower cost than an AWB system.

Although this particular resistance test did involve measurement of *changes* in air-content, it did not involve *absolute* measurements of the air-content. The MAV test was capable of determining very quickly and simply whether a resistance change had taken place in the fresh concrete under the forces of vibration (or time of vibration). The plan was to interrupt the process of consolidation periodically and measure the AC resistance of the specimen using the MAV method while the motion of the concrete was at rest.

**Simplicity and economy of AC-resistance measurements.** Development of an AAV device would be less expensive than the development of an AWB device, and an AWB device would be less complex and expensive than an AIB device. For that reason, it was desired to begin with the simple and less expensive MAV method with hopes that it would work and give sufficient resolution (e.g., WES built an AAV technique to detect the presence of grout in muddy river water (Ainsworth 1979)). Also, it was understood from the start of the CPAR project that if the fresh concrete exhibited significant capacitance, it would be necessary to make AC-impedance measurements using a bridge circuit (e.g., measurements on hardened concrete are known to require an impedance bridge measurement

rather than the simpler and less expensive Wheatstone bridge measurement method).

With *AC-resistance* measurements, only a simple magnitude measurement is made with the MAV, AAV, MWB, and AWB circuits. However, with *AC-impedance* measurements, both the magnitude and phase must be dealt with to get a proper measurement using the MIB or AIB circuits. In other words, *AC-resistance* measurements do not require the complexity of measurement of an *AC-impedance* measurement. This is true for a manual or automatic measurement system.

**Circuit configuration.** The MAV method had the following circuit configuration: An AC-power supply, a Wavetek Model 114 voltage generator, which fed a series circuit consisting of two resistances. The circuit consisted of the concrete as one resistance and a current resistor as the second resistance. A standard decade resistor box was used to select a current resistance of a few ohms (usually about 1/10 of the resistance of the concrete specimen). Figure 42 shows the diagram of the MAV circuit. A laboratory AC voltmeter was used to measure the voltage across this reference resistor. Knowing the value of the current resistance and the voltage across the reference resistor, Ohm's law can be used to calculate the current flowing through the fresh concrete. (In this series circuit, the current through the reference resistor is equal to the current in the concrete specimen.) Then, the AC voltmeter was used to measure the voltage across the concrete specimen. From the known calculated current and the measured voltage across the fresh concrete, Ohm's law was used to calculate the AC resistance of the concrete.

**Test fixture.** A test fixture for containing the fresh concrete was built in the next task. A wooden box (305 by 305 by 305 mm (12 by 12 by 12 in.)) made of marine plywood was built, and metal electrodes were located on two of the opposite walls on the inside of the box. The box was made rugged so that it would withstand numerous fillings and dumpings of fresh concrete. A thin sheet of copper stock metal was used as an electrode material and 76-mm- (3-in.-) diam electrodes were constructed from the metal. The two electrodes were bolted onto opposite walls of the wooden box on the inside and had a 305-mm (12-in.) spacing between them. The electrodes were also bonded to the walls of the container to prevent concrete from flowing behind the electrodes. This made it easier to remove the concrete from the box at the end of the test by troweling or dumping.

**Results.** Figure 43 shows the AC-resistance as a function of the number of insertions of the poker vibrator into the concrete. WES investigators tested several containers of concrete having the same mixture design. One sample of the concrete had an AC resistance of about 75 ohms, and another had a resistance of 68 ohms in the unconsolidated condition. The first one dropped 9.9 percent down to 67.6 ohms, and the other dropped 3.9 percent down to 65.8 ohms after consolidation by vibration. Appendix A gives the details of how to calculate the AC resistance using the MAV method. The results were very encouraging as the data seemed to indicate that the degree of consolidation (air content) was related to the AC resistance. Also, since the voltage across the reference resistor and the

fresh concrete added to equal the supply voltage, it appeared that all voltages were in phase; therefore, the fresh concrete was purely resistive. (For reactive circuits, the voltages across two electrodes components connected in series will not add up to equal the supply voltage.) A new batch of concrete with the same mixture design was tested again, except it was vibrated by a shaker table. The unconsolidated resistance was 65.9 ohms, and the consolidated concrete measured 57.2 ohms. This agreed fairly closely to the previous measurements. Figure 44 shows the AC resistance versus the activation number (number of times that power was switched on) of the shaker table.

It was determined that higher resolution measurements were needed than could be obtained with the MAV method; therefore, no effort was made to develop an AAV method.

### **MWB measurements**

**Uniform consolidation and improved resolution.** For more controlled laboratory experiments, it was decided to consolidate future concrete with a shaker table rather than with a poker vibrator to obtain more uniform consolidation throughout the container. Also, use of the shaker table prevented the possibility that the metal poker vibrator might short-circuit some of the electric field lines between the electrodes and disturb the symmetry of the electric field when later making dynamic measurements.

**Need for proof of relationship.** An unmistakable relationship had been observed between the AC resistance of fresh concrete and the time of vibration. The premise of the WES investigators was that the change in AC resistance likely represented the change in air content of the mixture. It was necessary now to obtain more direct proof that the supposed premise was true. A method was needed to measure the air content on the same specimen and preferably at the same time that the AC resistance was measured. The reader may question why the air content was not determined by standard means, i.e., by using one of the three methods for measuring air content mentioned in the Introduction or by drilling cores for the partially consolidated concrete, sawing them into slices, and measuring their air content by petrographic means. The primary reason that these methods were rejected was that only one pair of air-content versus AC-resistance coordinates could be obtained on a given sample of vibrated concrete. It would have required a series of samples to get a series of points to develop a correlation curve. It was desired to develop a correlation curve with no less than 10 pairs of air-content-versus-AC-resistance values for the *same sample* of concrete during consolidation.

**Advantages of a Wheatstone bridge measurement.** Four advantages of a Wheatstone bridge measurement over the ammeter-voltmeter method are: (a) the output voltage can be zeroed for the unconsolidated concrete making it easier to find recording equipment with the proper resolution; (b) the output can be amplified for greater sensitivity since there is no tare resistance and hence no tare voltage as with the ammeter-voltmeter method; (c) a smaller current is possible in

the concrete, which is less likely to produce heating effects (too small a voltage, however, is bad because of sensitivity to temperature and stray electromagnetic fields); and (d) the resolution is better.

**MWB measurements with ESI bridge.** The resolution of the resistance measurements was improved with the use of the MWB. (The development of the automatic system was going on concurrently with the manual measurements and is explained in a later section.) Numerous AC-resistance tests were made with an ESI Model 250 DA universal impedance meter in an MWB configuration. (The meter has the capability to measure the resistive portion of impedance in circuits that combine resistors, capacitors, and inductors.) (See Figure 45 for a description of the front panel functions, Figure 46 for a schematic diagram of the bridge connections for measuring the AC resistance of the fresh concrete, Figure 47 for an illustrative diagram of the measurement setup, and Appendix B for details of the measurement procedure.)

Both mortars and concretes were tested to develop an approximation of the range of resistance seen across the various mixtures and also to determine the AC-voltage level needed to power the bridge that would allow measurements having a satisfactory signal-to-noise ratio. A shaker table was used to consolidate the material in a series of discrete vibration runs. The resistance measurements were made between the vibration runs under static conditions. That is, vibration was maintained for approximately 1 sec and interrupted, and then the concrete resistance was measured with the MWB system while the vibrator was quiescent. The MWB method requires several minutes of the technician's time to make a resistance measurement.

A *mass-density versus air-content* curve was measured for a particular mixture. Then a *mass-density versus AC-resistance* curve was measured for the same mixture. Then a curve of *air-content versus AC-resistance* data was determined analytically by eliminating the common parameter, mass-density.

**Air-pot and constant-volume mass measurement (CVMM).** It was decided to restore the volume of a container of concrete and measure the mass of the specimen after each interval of vibration as a method to determine the mass-density and also to measure the AC-resistance. This method is referred to as the constant-volume mass measurement (CVMM). It is a routine procedure in many concrete testing organizations when mixing a batch of concrete for personnel to measure the air content using the pressure method (ASTM C 231). See Appendix A on the instructions for determination of the air-content-versus-AC-resistance curve of a concrete specimen. Since the pressure pot has a known volume, the mass of the specimen was determined and the density calculated. With those two numbers, the air content for a given density, the complete curve for air content versus density can be determined for that particular concrete. Since a 1-percent drop in air content during consolidation process results in a 1-percent increase in the density or mass of the sample, a slope and y-intercept can be determined and an equation formulated that relates air content to density for that sample of concrete. This method allowed the probes to always be sensing the same volume of concrete.

**Determination of equation.** Figure 48 shows the mass-density as a function of air content based on one air-pot measurement on 11 May 1994. The mortar had a density of  $1,986 \text{ kg/m}^3$  ( $124.0 \text{ lbm/ft}^3$ ) with an air content of 15.6 percent. Appendix C gives the calculations for obtaining the air-content-versus-AC-resistance curve using spreadsheet calculations. Also, the calculations are given for determining the linear equation that relates mass density and air content. The slope and y-intercept are derived from the straight-line relationship, and the equation is plotted. The y-intercept is essentially the theoretical solid density, which is the mass-density of the concrete without air. The equation is then used to calculate the air content for a particular mass measurement in the next procedure.

$$D = mA + D_0 \quad (2)$$

where

$D$  = density of concrete,  $\text{kg/m}^3$  ( $\text{lbm/ft}^3$ )

$m$  = slope of curve,  $\text{kg/m}^3$  ( $\text{lbm/ft}^3$ )/percent

$A$  = air content, percent

$D_0$  = theoretical solid density for zero-percent air

**Measurements on mortar.** The two selected mortars are described in the following narrative. The mortars were given an excess amount of air entrainment in order to develop an expanded correlation curve. Mortar no. 1 had 15.6 percent of air and 4,746 kg of cement per cubic metre (800 lbm of cement per cubic yard), and mortar no. 2 had 9.6 percent of air and 3,559 kg of cement per cubic metre (620 lbm of cement per cubic yard). Both had a w/c of 0.5. The data and method of analyzing are shown for mortar no. 1 in Appendix C. The measured data were the series of pairs of values of mass of the concrete in the 152-mm- (6-in.-) diam by 305-mm- (12-in.-) long cylinder mold and the corresponding AC-resistance of the concrete as measured by the ESI MWB. From the measured mass and the known volume of the concrete, the mass density is calculated. From Equation 2 mentioned above, the air content is calculated for each mass value. Figure 49 shows the AC resistance plotted against the air content for mortar no. 1. It appears to be a linear relationship. Figure 50 shows the AC resistance plotted against the air content for mortar no. 2. It also appears to be a linear relationship.

**Parametric studies on impedance of various mixtures.** The WES team studied a variety of concrete mixtures with different resistance properties that could potentially result from various placements in a field situation. Variables such as w/c, presence of admixtures, etc., were incorporated into the mixtures to be evaluated. The range of resistance and amplitude of excitation voltages and other parameter values were determined as a basis for finding the range of instrumentation parameters necessary before a field package could be designed and built. The range of resistance varied from 30 ohms to about 400 ohms. Ten AC volts seemed to be a satisfactory excitation voltage for the bridge network to

keep noise to an acceptable level and to maintain safety. It was learned that a higher w/c or a higher cement content would lower the resistance of the consolidated mixture. More aggregate or more air would raise the resistance value of the consolidated concrete. In general, mortar reads lower in resistance than concrete. A shaker table was used in these studies as the consolidating source since the development of the new prototype RV was not yet available. It was noted that entrapped air was released at a high rate during the period of consolidation and the entrained air was released at a much slower rate.

### **AWB measurements**

**Findings from manual techniques.** The first measurement technique (i.e., the AC MAV method) was important to establish that an electrical measurement could be the basis of a CM, and the second technique (the AC MWB method) was important as a basic resistance measurement technique to improve the resolution of resistance readings over that of the MAV method and for the understanding gained from the Wheatstone bridge measurements as a basic foundation for the AWB device. The CVMM, based on restoring the fresh concrete to the full volume of the cylindrical mold after an interval of consolidation, was important for establishing that there was a definite relationship between electrical resistance and air content.

**Need for automatic technique.** The next step required that a technique be established that would (a) make continuous AWB measurements during the consolidation process, (b) amplify the output voltage from the bridge for better resolution, and (c) output the data in a form that could be easily monitored by an equipment operator. The vibration process typically takes less than 10 sec at a particular location in the concrete to consolidate it. The manual methods required about 2 min to make a measurement, and that required interrupted vibration action. An automatic system was needed that was fast enough to make continuous measurements without vibrator interruption with only milliseconds of lag time between the indicated value and the actual value.

**Development of AWB system.** The initial experiments for making AWB consolidation measurements were performed with commercial laboratory equipment. A sine-wave function generator (Wavetek), a Wheatstone bridge consisting of a full wave rectifier and a passive lowpass filter, a digital storage oscilloscope, and a vibrating table were used to evaluate the electrical resistance of the fresh concrete as a function of the continuous time of vibration. Two metal rods whose spacing could be changed were used as electrodes.

The other two earlier methods of measurement, the MAV and the MWB methods, did not permit continuous resistance (air-content) measurements to be made during the consolidation process. Both methods required measurements to be conducted during the interval of interruption of the consolidation process. Measurements up to now with the MWB had been performed by a *balanced bridge measurement*, since the laboratory test device had a calibrated bridge resistance that could be adjusted to equal the resistance of the fresh concrete.

However, for purposes of data acquisition speed for a dynamic measurement, the AWB system required an *unbalanced bridge measurement*. A *balanced bridge measurement* was made only for the initial measurement for the unconsolidated concrete. From that time to the completion of the consolidation process, an automatic *unbalanced bridge measurement* was made. That is, the system continuously measured the unbalanced bridge voltage from the output of the bridge as the resistance of the fresh concrete changed during consolidation. The system was calibrated to resistance after consolidation calibration by correlating the DC output voltage against resistance values from a decade resistor box that was substituted into the concrete arm of the bridge.

**First prototype.** The first prototype AWB CM, built for field use, was constructed using IC's, and passive circuit components. (Passive components, such as resistors, capacitors, diodes, etc., do not exhibit gain or contribute energy as active components do.) The laboratory Wavetek function generator was soon replaced with an integrated circuit (IC) based function generator. Five IC's were configured to serve as a function generator to generate the 1-kHz sine wave to the Wheatstone bridge. The chips consisted of four op-amps configured properly to generate the signal and one buffer amplifier. A differential amplifier amplified the bridge output and also isolated the bridge circuit. A full-wave rectifier and passive low-pass filter were used to convert the AC-signal from the Wheatstone bridge into a proportional DC output and remove most of the high-frequency ripple. This DC output changes linearly with the change in resistance of the active arm (concrete probe) in the bridge.

**Variable bridge supply voltage.** One problem encountered in the first AWB prototype was that the bridge excitation voltage varied while consolidation measurements were being made. A critical requirement for any unbalanced bridge measurement is that the voltage applied to the bridge remain constant as the load (bridge resistance) changes. For this reason, a pair of IC-current amplifiers (line drivers) were used to replace the buffer amplifier. These amplifiers better maintained the bridge supply voltage initially selected as the resistive load of the bridge changed due to the change in concrete resistance (variable current drawn) during the consolidation process.

**Low response time.** Another problem with the first AWB prototype consolidation circuit was the slow response time. The indicated AC-resistance lagged behind the actual resistance of the concrete for a second or so during the consolidation process. In order to achieve a faster response time, the low-pass filter pole had to be increased in frequency to a more optimum value. However, a more favorable response time resulted in a trade-off with the measurement accuracy of the AWB system. Moving the filter up in frequency permitted more undesired high-frequency AC ripple to pass through the filter. This problem was overcome in the final circuit by using an RMS-to-DC converter IC, which had a fast response time with no AC ripple.

**Second prototype.** The second AWB prototype CM was constructed with improved electrical components. IC catalogs and data books were searched to

find electronic components that could improve the measurement performance of the CM.

**Noise.** In the laboratory measurement of AC resistance during the consolidation process, experiments indicated that electrical resistance measurements made on small volumes of fresh concrete 152-mm- (6-in.-) diam and 305-mm- (12-in.-) long cylinder mold) did not produce the noise levels experienced with larger volumes (1.22 m square (4 ft square) and 305 mm (12 in.) deep). Larger concrete volumes are more susceptible to the reception of stray electromagnetic fields. This reception interferes with the measurement process. Test data from a large concrete volume contained energy not only at 60 Hz (standard power line frequency), but also energy of an unknown source at 20,000 Hz. This problem was later overcome by addition of a high Q bandpass filter.

**Bandpass filter.** A narrow-bandpass filter that allowed only the 1-kHz operational frequency of the meter to pass was needed to block the unwanted frequencies. The required active filter needed high stability, tuneability, and sharp cutoff frequencies. A few active filter circuits were designed and tested by computer simulation and built in-house but were too complex or lacked the necessary performance to do the job. An off-the-shelf filter, possessing the characteristics mentioned, was purchased and was integrated into the evolving CM. The filter was a high-performance bandpass filter with adjustable gain that removed unwanted noise and distortion in the signal. The center frequency of this filter was set by adjusting four resistors external to the module. The quality factor (Q) was fixed at a value of 10. Successful laboratory tests on large concrete samples were performed with the AWB CM containing the new filter.

**Final circuit.** The final circuit was constructed on a single etched (engraved by acid) circuit board and packaged in a fiberglass box with a hinged top. Two 15-volt rechargeable camcorder batteries were used as the power supply. An opened CM is shown in Figure 51. Figure 52 shows a block diagram of the basic components of the final AC CM. A waveform generator IC is used to produce a 1-kHz sine wave. Two line drivers (amplifiers) IC's are used to buffer the output of the waveform generator and therefore maintain a constant supply voltage to the bridge during resistive load changes. The final bridge excitation is 2.2 volts at 1 kHz. The bridge is constructed using modular precision resistors (described in the following section), external capacitance switches, and a 10-turn zeroing potentiometer. A high-quality instrumentation amplifier serves to buffer the bridge output from the rest of the circuit while providing a controllable differential gain function. A bandpass filter then removes unwanted energy and provides some additional signal gain. An RMS-to-DC converter then converts the AC signal into a proportional DC signal. The output is then sent to an analog DC meter on the front panel and to a comparator IC. The comparator allows a threshold to be set with the internal potentiometer.

**Plug-in modules.** An IC socket and a mating solder pin connector allowed for different bridge resistances to be plugged into the circuit. If the measurement being made had a concrete resistance different from the bridge resistance

currently plugged in, the bridge circuit of the CM could be removed and replaced with a bridge unit of appropriate value. Mixtures varied from 30 to 400 ohms during the course of this investigation. The resistance value of the fresh concrete changed if the probe separation distance, w/c, cement content, etc., changed. However, for a given construction project, there is usually only one mixture design and one separation distance for the probes used and therefore only one bridge unit may be needed.

**Testing AWB.** The WES team tested the AWB CM on one standard mixture of fresh concrete. The mixture chosen was a typical one used in the field for pavements and paving machines. A prototype RV sent to WES from the CPAR partner was used to consolidate various concrete batches and to gather data for developing the AWB CM. A conventional shaker-table vibrator had been used earlier to bring the concrete mixtures to various levels of consolidation.

### **AIB measurements**

**Resistance-dominated impedance.** When AC-resistance measurements were being made on the fresh concrete and mortar with the MAV method, the voltage across the reference resistor added to the voltage across the fresh concrete to equal the supply voltage. This indicated that the voltage was in phase across both components and there were no reactive (in the electrical sense) components in the fresh concrete. To the degree of the accuracy of the measurement, this was true. However, because many of the earlier measurements had exaggerated air contents, the resistive component may have dominated the reactive component. To phrase it another way, the phase angle was near zero for the mixtures with high air content, and the reactive component was so small it was not detected.

**Modification required.** Problems with the AWB circuit developed later on in the project for some mixtures while obtaining a zero for the unconsolidated condition. It was determined that the fresh concrete had some capacitive reactance, in addition to its resistance, that impeded the capacity of the CM to obtain a bridge balance on the unconsolidated concrete, thus limiting maximum sensitivity. Figure 53, the schematic diagram of the AIB, shows the bridge circuit at the top right corner of the diagram. Two rotary switches containing a series of capacitors was inserted into the arm adjacent to the concrete probe arm to balance the reactive component in the concrete. A variable resistor had already existed in series with the concrete probe to balance the resistive portion. The other two completion resistors that made up the four arms of the bridge were purely resistive. This system then became an AIB to replace the AWB. By definition, a Wheatstone bridge is used only for purely resistive measurements.

### **Design considerations**

**Instrumentation amplifier.** An instrumentation amplifier (another op-amp) was used to amplify the AC differential output from the bridge. The gain of this

amplifier is set by a 10-turn fine adjustment potentiometer located on the front panel of the CM.

**Consolidation indicator.** Two methods were used to indicate the completed consolidation: an analog meter and a light-emitting diode (LED). The root-mean-square (RMS)-to-the-DC-converter IC produces both a fast response and an accurate DC signal proportional to the amplitude of the incoming AC signal. This DC output is displayed on the analog meter on the front panel of the CM. A Bayonet Neil Councilmen (BNC) connector on the front provides an interface connection for external equipment for recording or displaying the output such as a digital oscilloscope or data logger. Also, an IC comparator is used to set a threshold level past which a green LED on the meter will light up to indicate completion of consolidation. Excess time spent with the green light on could mean that the paver is going too slowly and that entrained air is being driven out of the concrete. The correct speed for the paver in terms of proper consolidation is at the point where the green light is just blinking on and off.

**Probe position.** Several requirements were placed on the metal probes that were submerged in the fresh concrete to sense current flow. It was decided not to use aluminum for constructing probes because of its chemical reactivity with concrete. Also, since water tends to rise to the surface of the concrete during consolidation, the surface is more electrically conductive than just below the surface. Both probes should be electrically insulated from the concrete surface. Electricity always takes the path of least resistance, so the lower impedance of the surface water will introduce misjudgments about the degree of consolidation in concrete.

**Design of probes.** Small-diameter metal rods were selected for the probes for a couple of reasons: (a) probes with a small area have a low capacitance, and (b) the chance of cavitation around the probes due to the intense vibrational field or movement of the paver during consolidation needed to be reduced. In a normal dielectric medium, the capacitance between two electrodes (probes) is equal to the *area of the electrodes* times the dielectric constant of the material between the probes divided by the separation distance of the probes. The geometry of the vibrator shaft and forks, reinforcement position, direction of paver travel, and height of the fresh concrete above the final pavement surface in the paver were all considered in constructing the final probes. Polyvinyl chloride (PVC) pipe was used to insulate the portion of the probes near the concrete surface. The completed probes are shown in Figure 54.

**Electrical insulation of vibrator forks.** It was not possible to place the electrodes outside the vibration field of a mechanical slipform paver due to the geometric constraints. Because the main shaft of the vibrator cuts through the electric field existing between the probes of the CM, electrical insulation of the vibrator shaft is beneficial. The forks are already insulated because they have a layer of polymer concrete on them. Some insulation may also be needed for the steel walls of the paver in the vicinity of the probes.

**Construction of field meters.** Electronic components were purchased to build two CM's for the final prototype. The circuit-board pattern used to etch the final circuit board is shown in Figure 55. Table 5 shows the list of parts for the various integrated circuits.

<b>Description</b>	<b>Manufacturer</b>	<b>Part Number</b>
Waveform generator	Harris, Inc.	ICL8038CCPD-ND
Operational amplifier	Burr Brown, Inc.	OPA602BP
Line driver (amplifier)	Burr Brown, Inc.	OPA633KP
Instrumentation amplifier	Burr Brown, Inc.	INA118P
RMS to DC converter	Analog Devices, Inc.	AD637JO
Bandpass filter	Frequency Devices, Inc.	764BQ10
Comparator	Analog Devices, Inc.	CMP04FP

### **Operation of meter**

**Idealized resistance curve.** Typically, the large decrease in resistance of the fresh concrete occurs in the first 2 to 5 sec of vibration. Most of the measurements made in this investigation had two distinct parts to the AC-resistance-versus-time-of-consolidation curve, as can be seen in Figure 56. The initial drop in resistance is due to the loss of nonconductive entrapped air and occurs in a few seconds of vibration. The second part of the curve is due to the loss of entrained air and can continue for a large part of an hour if the concrete is continually vibrated. This quick initial expelling of air could be due to the fact that entrapped air voids may be larger in size than entrained air voids making them more buoyant under the vibrational field.

**Calibration required for each mixture.** There are an infinite number of curves relating AC-resistance to time of vibration for the infinite number of concrete mixtures. Each mixture on each project will require its own calibration. That is, there should be an AC-resistance value for an unconsolidated condition and a lower AC-resistance value for a consolidated condition. The conspicuous change in slope between the two parts of the curve is the point where the entrapped air has been removed. The resistance value that exists at the intersection of the entrapped and entrained curves will be the terminal value that the operator is looking for. It is not necessary to convert the AC-resistance to an air content number. That would be an extra effort for an equipment operator. He wants to know only when he has properly consolidated the concrete. In summary, the intersection of the two parts of the curve is the desired degree of consolidation.

**Reactance is constant.** It is significant that an impedance bridge balance (resistance and reactive components) is required only for the unconsolidated concrete. Apparently during the consolidation process, the resistive changes in the concrete dominate over any reactive change that might occur such that continued reactive balances during the consolidation process are not necessary once the initial reactance is balanced out for the unconsolidated concrete. From that time, the measurement can be and is an unbalanced resistive bridge measurement. If the reactance of the concrete had changed significantly during the consolidation process, it could have created problems for the meter design. (It would take sophisticated hardware to automatically balance both the resistance and capacitance during consolidation.) It would not be as economical to develop a circuit that could balance the resistance and capacitance fast enough to measure the resistance of the concrete as it is to simply measure the unbalanced voltage from the bridge. It is fortunate that the concrete behaved as it did, because it reduces the complexity of the measurement and the development effort.

**Operation of CM.** Numerous tests were made to study the operation of the CM. Figure 57 shows how a resistance change inserted into the probe arm with a decade box produced a linear change in output voltage. The top plot shows the DC voltage output from the meter when 1 ohm was inserted, when 2 more ohms were inserted, when 3 more ohms were inserted, and finally when 4 more ohms were inserted making a total of 10 ohms. Then the voltage could be seen dropping as the resistances was removed in reverse order. This test also helps determine response system time. Figure 58 shows how blowing air into a thin mixture will change the resistance of the mixture as the air bubbles pass between the probes. (Note that the sensitivity (gain) was turned way up.) The cement mixture had a low viscosity, and the bubbles rose to the surface without the mixture requiring vibration. Figure 59 shows how a dielectric (insulator) inserted into the space between the electrodes increases the resistance. Also, although not shown, inserting a conductor into the space between the electrodes will reduce the resistance. Figure 60 shows the percentage change in the amount of air released during the consolidation process on a mixture of concrete.

**Calibration procedure.** Unconsolidated concrete will have a definite resistance value for a particular design mixture of concrete, and the consolidated concrete for the same mixture will have a definite value of resistance, somewhat lower than the unconsolidated value. The operator can determine these values before the paver begins to move. For example, some concretes will require 3 sec to expel the entrapped air, and other concretes may take 5 or 6 sec to expel the entrapped air. The CM will determine the intersection of the entrapped-air/entrained-air resistance curve shown in Figure 56. The meter on the front panel of the CM must be adjusted during the calibration process with the front panel controls. First, the meter is zeroed with the bridge potentiometer, and then the capacitance is zeroed. That is, the needle of the analog meter is adjusted to read zero volts, for the unconsolidated resistance of 49 ohms, in this example (see Figure 61). Then the concrete is consolidated by vibration, and the gain-control is adjusted so that the needle reads full scale or some appropriate value near full scale. In this example, the needle is set to full scale, which corresponds to 38 ohms. As long as the needle remains near full scale during the paving

operation, the operator can be assured he is running at the correct speed for proper consolidation. Also, at and above the full-scale setting, a light on the front panel turns green to indicate that the concrete has reached consolidation. The light is off any time the resistance has a value to the left of the intersection between the two curves. It is green to the right of the intersection point.

As noted earlier, the air content is linearly related to the AC resistance. However, no attempt was made in the design of the CM for the operator to be able to determine the air content of the concrete. It is necessary to find only the point of proper consolidation. To simplify his work, he is required only to maintain the analog needle near full scale once the CM has been calibrated on a sample of the concrete. First, a calibration measurement is made on the unconsolidated concrete, and then a second calibration measurement is made on the consolidated concrete. The CM does not determine whether the concrete was designed properly with the correct amount of air entrainment; it only determines whether the concrete has been consolidated properly.

### **Packaging of consolidation monitoring instrumentation**

WES researchers developed the specifications, designed the circuit, purchased the electronic components, and packaged the laboratory instrumentation in a portable field unit for monitoring the consolidation process. The laboratory equipment, which was bulky and complex and had broad functions, was replaced by field instrumentation, which was portable and simple to operate and had narrow functions limited to that required for the purpose of the consolidation measurement. Performance was also improved by features such as the bandpass filter, instrumentation amplifier, an RMS-to-DC converter, etc. The operation of the field instrumentation was simplified to the maximum extent possible to make it user friendly for an operator. The prototype instrumentation was packaged in an attractive and durable plastic housing.

### **Results**

A portable field device was designed, built, and tested by WES personnel. The system was a battery-operated device that could make continuous AC-resistance measurements during the consolidation process. This permitted air content measurements (or at least DC-voltage measurements proportional to the air content) to be made during the consolidation process based on an AIB measurement.

# 4 Study of Resonant Vibrator by WES

---

## Introduction

As stated in the Chapter 1 under the Scope, one task of WES was to study the new RV and develop measurement criteria to optimize the force and frequency of the RV to get efficient and productive operation.

A significant feature of the poker vibrator is its portability and easy access to difficult locations. Its utility is the capability to be used by one man. It will not likely be replaced in the foreseeable future except for situations where mechanical paving is involved.

## Experimental Work

### Test setup

Familiarity was first made with the two hydraulic adjustments to the shaker: a flow adjustment and a pressure adjustment. The shaker is the equipment that contains a rotating eccentric mass and causes vibration of the vibrator itself. The shaker is driven by hydraulic pressure from a suitable pump. The vibratory response was not noticeably affected by the flow adjustment but was highly affected by the pressure adjustment. A determination was first made on how to adjust the pressure and flow rate of the hydraulic fluid to achieve resonance at a proper force level. The WES team built a 1.3-m- (4-ft-) square wooden box for testing concrete with the RV. A smaller container would have interfered with the normal vibration field because of wave reflections from the sides of the container. A heavy barrel filled with concrete was used to act as a reaction mass to dampen energy from the shaker that would have otherwise been sent back to the end loader whose hydraulic system was being used. WES obtained a set of hydraulic cables and connections for driving the new vibrator from the hydraulic system of the end loader.

## Laboratory sensors

Tests were performed with an accelerometer immersed in the fresh concrete. It was installed in a plastic housing to seal against moisture. The accelerometer was suspended in the concrete with a metal wire stretched horizontally across the 1.3-m- (4-ft-) form. It was positioned at a depth of 152 mm (6 in.) below the surface of the concrete for the laboratory tests with the accelerometer about 457 mm (18 in.) horizontally from the center of the RV shaft. The wire was perpendicular to the axis of the accelerometer and allowed free movement of the accelerometer.

Another configuration had the accelerometer bonded solidly to the vibrator fork tips and then the shaker housing. A strobe light was also used to visually observe vibration rates and modes and confirm accelerometer readings. A digital storage oscilloscope was used as a recorder to capture the vibration data during consolidation.

## Slow hydration

A pavement mixture with a slump of 25 mm (1 in.) was used for testing the vibrator. A retarder was added to the concrete mixture to give more time for testing. The mixture would continue to get stiffer with time resulting in a continuing decrease in slump. The WES team batched enough concrete to obtain a depth of about 254 mm (10 in.) in the 1.3-m- (4-ft-) square box. The placement volume was 0.37 m (13 ft<sup>3</sup>).

## Analysis

The WES team thought initially that the fundamental frequency would increase with an increase in pressure and they could note the frequency of resonance by observing the highest amplitude of the signal. That was not the case. Resonance seems to be related to the number of harmonics created prior to mechanical breakdown of the fresh concrete rather than the amplitude of the fundamental. The data needed to be analyzed further to clarify this observation.

## Results of frequency tests

Resonant frequency vibration tests were performed to answer questions concerning the optimum vibrator speed, other monitoring parameters, and the method to adjust it for the proper speed. The WES team was asked by Innotech, Inc., the CPAR industry partner, to verify Innotech's resonant frequency measurements. The horizontal cross pieces (forks) were observed vibrating vertically at approximately 150 Hz. Vibration modes at 90 and 150 Hz were found to be of equal amplitude when the vibrator speed was swept through its frequency range. The velocity is proportional to the product of amplitude and frequency. Hence more kinetic energy is delivered to the concrete at 150 Hz

( $1/2 \text{ mass} \times \text{velocity}^2$ ) Figure 62 shows a series of curves where the resonant frequencies at various amplitudes were collected while the vibrator speed was varied from low to high frequency with discrete changes in the hydraulic pressure. The accelerometer was mounted on one of the vibrator fork tips to measure the vertical acceleration.

### **Vibration action of new vibrator**

WES personnel first saw a fundamental at 83 Hz and very few harmonics. Then, at higher force levels, the harmonics began to multiply significantly. At the higher pressure, the harmonics extended out to about 1 kHz. The harmonics appeared in multiples of 83 Hz. However, this was the condition before the fresh concrete broke down and changed from a stiff mixture to a fluid-like structure (Alexander 1977). After breakdown of the mechanical impedance, the harmonics dropped out. Many modes of vibration were observed. More attention was directed toward the measurement of the vertical movement of the tip as this mode appeared stronger than the others.

The radius of action was significant, and the action of the vibrator was furious. The radius of action is greater from either side than in front of and behind the vibrator. The left side, looking from the driver's seat of the end loader, had a larger radius of action. However, the input and output hydraulic hoses into the shaker can be reversed, and maximum motion will occur on the other side of the vibrator. Performing a complete modal analysis of the new vibrator would be a significant project in itself.

These were observed with the vibrator operating in air and concrete. The system can be operated in air only at low pressures. Without the constraint of the fresh concrete, it would soon destroy itself.

### **Potential uses of vibrator**

The system is limited to mechanized production of concrete. It will not eliminate the poker vibrator for situations where the vibrator will be handled by an individual. The vibrator can be used currently for any flat work: pavements, canals, runways, etc. The higher frequency mode is believed to be more useful for consolidation because it creates a larger radius of action and thus delivers more energy.

### **Inability to test CM under dynamic conditions**

Construction Machinery Inc. (CMI), the private organization that plans to commercialize the resonant vibrator, has not installed the final vibrators on a paving machine, so it was not possible to test the CM in motion. Innotech had previously tested a number of prototype vibrators on a simulated paving system, but the CM was not at the final stage of development at that time. The WES team

did not have the equipment necessary to test the CM in a dynamic situation by moving the electrodes through the mixture. Also, some limited work was performed to determine if the vibration field produced any noise in the readout.

A prototype version of the RV and the portable CM has been delivered to CMI, a potential manufacturer of the new vibration system.

# 5 Conclusions and Recommendations

---

## Resonant Vibrator

### Achievements

A new type of concrete vibrator, a resonant vibrator (RV), was designed, built, and tested. The new vibrator is energy efficient as the result of its resonant-frequency operation. Large amplitudes of displacement can be obtained as the frequency of the hydraulic shaker that drives the RV is adjusted to match the resonant frequency of the system. Hence, the system engages a larger volume of fresh concrete during the consolidation process than conventional vibration systems do. The system operates at approximately 150 Hz, which is an optimum frequency for the consolidation of concrete. Analysis of cores taken from concrete vibrated by a conventional vibrator and by the new vibrator shows that the compressive strength and porosity of the consolidated concrete are improved by use of the new system.

This project produced an effective and efficient concrete consolidation system for slipform paving operations. The new system relies on the technique of resonant vibration to enhance the properties of concrete. It can thus enhance the level and uniformity of concrete consolidation and thus the characteristics of concrete without a change in the raw materials and mixture proportions. Alternatively, the system can help achieve the targeted performance characteristics with more economical combinations of raw materials and concrete mixture proportions.

### Technical challenges

The project had to address two technical challenges:

- a. Shakers, which are used to apply vibratory forces to the RV system, are not currently manufactured to operate at the relatively high resonant

frequency of the system (156 Hz); these shakers require an improved cooling system to provide longevity at an operating frequency of 156 Hz.

- b. Field operation conditions demand a very long fatigue life from the system. Prudent selection of the steel and welding/heat treatment conditions is crucial for ensuring the fatigue life of the system. The need for long fatigue life also limits the vibratory force amplitude which can be safely applied to the system.

### **Additional work performed**

In order to address the recurring fatigue failure problems during the development of the RV, it was finally decided to reduce the vibratory force amplitude and to select a more fatigue-resistant steel for manufacturing the consolidation system. Meanwhile, Innotech researchers also tried revising the structural detailings of the system in order to eliminate stress risers and increase its fatigue life.

### **Revised structural detailings**

In order to enhance the fatigue life of the system, the researchers tried to minimize the stress concentrations within the structure. Figure 63 shows the Innotech conventional design. Figure 64 shows an alternative detailing of the connections where sharp stress-risers are eliminated from the critical connection areas. In an alternative approach (Figure 65), the sharp corners at connections are eliminated by simply bending the steel rods at elevated temperatures (rather than welding different bars together). The alternative designs of Figures 64 and 65, however, did not yield major improvements in fatigue life.

Commercialization was not complete because of time and funding constraints. More prototypes had to be constructed than was originally expected, for both the RV and consolidation meter (CM), before the development was satisfactory. The Minnich shakers that drive the RV are currently being modified for cooling purposes. The shaker and RV will be tested using the laboratory system of CMI. Once the laboratory test is satisfactory, the RV and shakers will be tested in the field on a slipform paver and commercialized by CMI of Oklahoma City, OK.

The project constraints did not permit testing the system on a canal as stated in the CRDA objective. Also, the internal vibratory system does not employ surface vibration as stated in the CRDA because of geometric constraints that prevented its development. The system is not ready for the construction industry as its performance still remains to be demonstrated on a slipform paver under actual field conditions. CMI or any other company will not commit the funds for commercialization until successful tests are performed in the field. It is recommended that further funds should be sought from the Federal Highway Administration (FHWA) to test and possibly modify the system for field conditions.

Because the RV operates at a higher frequency than the shakers are designed for, the shakers are not capable of driving the RV without heating up. CMI, Inc. and Minnich, Inc. are designing and building either an air- or oil-cooled hydraulic shaker to drive the RV before further testing.

### **Commercial sensor**

The accelerometer worked well encased in a plastic housing and suspended in the mixture by metal wires connected to opposite sides of the container. However, a different method will be needed to measure resonance when the CM is manufactured commercially for use on the paving machine. Although an accelerometer was used as the sensor in the research investigation, a less expensive sensor might be an encoder or some other type of sensor to measure the rotation speed of the shaker shaft for the commercial unit.

### **Tachometer needed**

By turning the vibrator motor at 90 revolutions per second (rps), the 90-Hz resonant vibration mode is most efficiently excited. The radius of action of the vibrator, however, was observed increasing at higher rotational speeds. The maximum rotational speed of the vibrator shaker is 100 rps. Near the upper limit of the vibrator, a 145-Hz vibration mode appeared at the vibrator tips. To safely excite this mode, the eccentric motor mass of the vibrator should be reduced, or another motor should be used to increase the frequency of the vibrator. Monitoring vibrator speed is possible with an accelerometer and oscilloscope, but a rotating-shaft sensor (tachometer) would be more economical for commercial applications. The other alternative would be to monitor the differential pressure between the inlet and outlet hydraulic lines on the vibrator and calibrate this pressure against vibrator speed (frequency).

From the experiments conducted by the WES team, it was recommended that a simple tachometer be used to monitor the correct frequency of operation. It is too expensive to use a strobe light or accelerometer. CMI and Innotech are cooperatively developing a tachometer system whose sensor is built into the new oil-cooled shaker.

### **Plans for new shaker**

The design of a new shaker is necessary. The current shaker is not designed to handle the power and high frequency of the new system. Although the new vibrator draws considerable energy, its radius of action is greater than the currently available poker vibrators.

## Consolidation Meter

A CM that measures the change in air content during consolidation was designed, built, and tested. It was determined that the electrical impedance of the concrete is directly related to the amount of air in fresh concrete. Typical ranges of impedances for fresh concrete pavement mixtures were determined in the laboratory as needed information for designing a CM. A number of different electrical measurement circuits were tested, but the final system was based on an AIB circuit. Two prototypes were built for making continuous dynamic measurements in the field.

Four measurement systems were used in the development of the CM. Two of the systems were manual tests: the MAV method and the MWB method. It was necessary to interrupt the vibration process periodically in order to measure the AC resistance of the fresh concrete with the manual systems. The other two systems were automatic tests: the AWB and the AIB. Both of these techniques permitted AC-resistance measurements to be made while the concrete was being continuously vibrated.

With the MAV meter, it was discovered that the AC-resistance of fresh concrete changes considerably with time of consolidation. With the MWB method, the resolution of the measurement was improved, and the method was used with the CVMM technique to relate the AC-resistance to the air content. Encouraging results from measurements made with the two manual systems convinced WES personnel that an automatic system should be designed and constructed. With the AWB, continuous resistance measurements were made for the first time against time of vibration. With the development of the AIB, some operational problems were eliminated from the AWB circuit, and the accuracy of the resistance measurements were considerably improved. The development of the new CM was successful. Detection of the change in air content of fresh concrete was possible with the electrical resistance phenomenon and even better with the impedance phenomenon. Dynamic measurements are now possible with the AIB CM. It was verified that entrapped air is removed at a faster rate than entrained air under a vibration field.

Fresh concrete responds electrically as a resistor and capacitor in parallel. The CM has the capability to make quality-control measurements during consolidation and provide results in real-time. The capability to perform instantaneous monitoring of the degree of consolidation during the consolidation process permits immediate feedback, so that one has the opportunity to prevent any problem of over-vibration or under-vibration by controlling the speed of the slipform paver. The system measures the electrical impedance of fresh concrete, and the impedance drops in a significant manner when the entrapped air is released through consolidation. The system is portable and is battery operated. The output, a voltage proportional to the air content, can be monitored by reading an analog needle against a calibrated scale, or the output can be registered on a strip chart recorder through a BNC connection.

The following is a list of possible benefits that can be expected from a successful demonstration under field conditions:

- The change in air content can be indicated in-situ during vibration.
- The need to drill cores to determine the adequacy of consolidation can be reduced or possibly eliminated.
- Statistics can be improved over coring as all locations can be tested inexpensively.
- Operation is simple and rapid.
- A permanent record can be made available for later inspection.
- System can provide a record of consolidation of concrete placed by a semi-skilled operator.
- Speed of paver can be estimated for complete vibration and it will no longer be subjective.
- Performance of each vibrator can be monitored as each vibrator can have its own CM.
- This the first known system to indicate the adequacy of consolidation of concrete during the vibration process.
- As an alternative application, the CM can be used to monitor concrete curing as an alternative to thermal and mechanical testing practices.
- Existing pavers can be retrofitted with CM.
- Quality control can be improved for concrete placement.
- Equipment is portable.
- Destructive testing can be reduced.
- Application can be extended to other vibrators such as hand-held pokers.

Although both subsystems, the RV and the CM, were designed to be incorporated into a mechanical slipform paver, the subsystems can also be easily modified to work for other types of construction. These systems have the potential to advance the state of the art of quality-control and quality-assurance measurements for the construction industry. Because supporting handles for the electrodes can be made any length, the CM offers the potential of testing any location in any placement, excluding the use of the slipform paver, to see if it received proper consolidation.

## Systems Combined

Although the two subsystems can operate independently of each other, the performance of the two products as a system should be better than one subsystem used alone. Cost savings cannot be given until the final field prototypes are built and evaluated.

The time and effort of development was longer than anticipated, but significant advancements have been made in creating two brand-new technologies that will improve construction practices in the future--hopefully the near-future. Shaker modifications are still underway for the RV system. The CM, however, is ready for commercialization.

To test and probe the two subsystems, a proposal for a thorough field evaluation program needs to be pursued with FHWA. This program will help promote the systems to Department of Transportation (DOT) and other potential organizations.

## 6 Commercialization and Technology Transfer Plan

---

The plans are for the RV to be marketed through a paving machinery manufacturer, CMI, Inc., who will be the licensee to Innotech International, Inc. Innotech will also provide technical services to end-users and will continue to further develop the system for broader application areas in the construction field. Innotech personnel are involved with various concrete committees within the Transportation Research Board (TRB), ASTM, and ACI and will make presentations and articles available about the new technology to the private sector.

WES is currently in the process of getting a patent for the CM, which should provide some incentive for the manufacturer. WES will introduce the new consolidation system to the U.S. Army Corps of Engineers and other Federal agencies through this CPAR technical report, *The REMR Bulletin*, (the newsletter of the Repair, Evaluation, Maintenance, and Rehabilitation Research (REMR) Program) and other Corps of Engineers publications. A paper and presentation on the CM was given in January 1997 at the TRB annual meeting in Washington, D.C. The paper was accepted for publication in the *Transportation Research Record* for August 1997.

Innotech's commercialization efforts are focused on cooperating with CMI to fully evaluate the system prior to market introduction. This evaluation focuses on the interaction of the vibration system with various electrical, hydraulic, and mechanical components of the slipform paving equipment. The complex nature of the various components of the slipform paver which could interact with the new vibration system makes the evaluation process at CMI quite exhaustive and time consuming. Upon successful completion of this evaluation process, CMI would install multiple vibration systems on a slipform paver for large-scale field application and evaluation. Innotech's cooperation with CMI is conducted within the context of a license agreement signed with CMI towards commercialization of the technology. The RV will first be tested in-house at CMI, Inc., after the fluid-cooled shakers are developed by CMI, Inc., and Minnich, Inc. Then the RV and CM will be tested in the field on a slipform paver and the system commercialized by CMI.

As noted, the two subsystems have not been demonstrated before interested parties such as DOT personnel and CMI, Inc. However, the research was successfully completed, and field prototypes have been designed, implemented, and tested in the laboratory. It is possible that the current prototypes for both the RV and the CM will require some modifications, as the field will introduce some new conditions and constraints on the equipment. Field tests are required to determine the particular problems encountered there and to promote the technology, as tests up to this point have all been in a laboratory setting. A 2- or 3-year FHWA project will be proposed to test the new system in various field situations on a slipform paver should CMI be reluctant to commit the necessary funds for field development, testing, and evaluation. Detailed plans for comparison field tests between conventional vibrators and the new RV vibrator will be laid out in the proposal. State DOT personnel will be familiarized with the research findings and their approval received in the form of a letter to submit it as a topic for an FHWA project to demonstrate the utility of the subsystems for improving the consolidation of concrete pavements.

# References

---

Ainsworth, D. L. (1979). "Grouting instrumentation, Old River Low Sill Control Structure," Miscellaneous Paper SL-79-23, U.S. Army Engineer Waterways Experiment Station, Vicksburg, MS.

Alexander, A. M. (1977). "Study of vibration in concrete, mechanics of motion of fresh concrete," Technical Report No. 6-780, Report 3, U.S. Army Engineer Waterways Experiment Station, Vicksburg, MS.

\_\_\_\_\_. (1992). "Review of measurement techniques and principles with potential application for development of a device to indicate adequacy of fresh concrete consolidation," Miscellaneous Paper SL-92-3, U.S. Army Engineer Waterways Experiment Station, Vicksburg, MS.

American Concrete Institute. (1986). "Behavior of fresh concrete during vibration," ACI 3091R, Farmington Hills, MI.

\_\_\_\_\_. (1987). "Guide for consolidation of concrete," ACI 309R, Farmington Hills, MI.

American Society for Testing and Materials. (1991). *Annual Book of ASTM Standards*, West Conshohocken, PA.

Designation C 39. "Test method for compressive strength of cylindrical concrete specimens."

Designation C 138. "Standard test method for unit weight, yield, and air content (gravimetric) of concrete."

Designation C 173. "Standard test method for air content of freshly mixed concrete by the volumetric method."

Designation C 231. "Standard test method for air content of freshly mixed concrete by the pressure method."

Designation C 457. "Test method for microscopical determination of parameters of the air-void system in hardened concrete."

American Society for Testing and Materials. (1991). *Annual Book of ASTM Standards*, West Conshohocken, PA.

Designation C 496. "Test method for splitting tensile strength of cylindrical concrete specimens."

Designation C 642. "Test method for specific gravity, absorption, and voids in hardened concrete."

Designation C 666. "Test method for resistance of concrete to rapid freezing and thawing."

Designation C 1040. "Standard test methods for density of unhardened and hardened concrete in place by nuclear methods."

Ansari, F. (1990). "A new method of assessment of air voids in plastic concrete," *Cement and Concrete Research* 20, 901-909.

Calleja, J. (1952a). "Effect of current frequency on measurement of electrical resistance of cement paste," *Journal of the American Concrete Institute, Proceedings* 49, 329-332.

\_\_\_\_\_. (1952b). "New techniques in the study of setting and hardening of hydraulic materials," *Journal of American Concrete Institute, Proceedings* 48, 525-536.

Eberle, W. R., and Bigelow, R. C. (1973). "Electrical dispersion characteristics of selected rock and soil samples from the Nevada Test Site," United States Department of the Interior Geological Survey, Special Projects-34, USGS-474-162.

Electro Scientific Industries, Inc. (1963). "Model 250 DA Instruction Manual," Portland, OR.

*Encyclopedia Britannica*. (1978). "Electricity," Vol. 6 of 30, 15th edition, William Benton Publisher, 568-572.

Ewins, A. J. (1990). "Resistivity measurements in concrete," *British Journal of NDT* 32(3), 120-126.

Gunnink, B. W., Enustun, B. V., and Demirel, T. (1988). "Determination of the pore structure of porous materials using electrical conductance," *Particulate Science and Technology* 6(1), 105-117.

\_\_\_\_\_. (1989). "Determination of the pore structure of porous materials using electrical conductance," *Particulate Science and Technology* 7(3), 241-251.

- Hammond, E., and Robson, T. D. (1975). "Comparison of electrical properties of various cements and concretes," *The Engineer* 199, 78-80,114-115.
- Hughes, B. P., Soleit, A. K. O., and Brierley, R. W. (1985). "New technique for determining the electrical resistivity of concrete," *Magazine of Concrete Research* 37(133), 243-248.
- Luppold, D. S. (1991). "Precision DC measurements and standards," Addison-Wesley Publishing Company, Reading, MA.
- Maguire, D., and Olen, M. (1940). "Report on an investigation into the electrical properties of concrete," *Transactions of the South African Institute of Electrical Engineers* 31(11), 301-313.
- Malhotra, V. M. (1976). "Testing hardened concrete: nondestructive methods," American Concrete Institute Monograph No. 9, 136-144.
- McCarter, W. J., Forde, M.C., and Whittington, H.W. (1981). "Resistivity characteristics of concrete," *Proceedings of the Institution of Civil Engineers. Part 2: Research and Theory* 71, 107-117.
- Moore, R. W. (1968). "Earth-resistivity tests applied as a rapid, nondestructive procedure for determining thickness of concrete pavements," Highway Research Record No. 218, Highway Research Board, 49-55.
- Nikkannen, P. (1962). "On the electrical properties of concrete and their application." Valtion Teknillinen Tutkimuslaitos. Tiedotus, Sarja III, Rekennus 60, 175. (In Finnish). Reference taken from report by Hughes, B.P., Soleit, A.K.O., and Brierley, R.W., "New technique for determining the electrical resistivity of concrete," *Magazine of Concrete Research* 37(133), 243-248.
- Olsen, M. P. J. (1987). "Consolidation of continuously reinforced concrete pavement," ACI Special Publication SP 96-4, 40-56.
- Ozyildirim, H. C. (1981). "Evaluation of a nuclear gage for controlling the consolidation of fresh concrete," Virginia Highway and Transportation Research Council, prepared for Federal Highway Administration, Richmond, VA.
- Rexnord, Inc. (1978). "Development of a device for continuous automatic monitoring of consolidation of fresh concrete," Federal Highway Administration, Washington, DC.
- Sarbacher, R. I. (1959). "Encyclopedic dictionary of electronics and nuclear engineering," Prentice-Hall, Inc., Inglewood Cliffs, NJ.
- Smith, A. W., and Wiedenbeck, M. L. (1959). "Electrical measurements." *Ammeter and Voltmeter Methods*. 5th ed., McGraw-Hill, New York.

- Sriravindrarah, R. and Swamy, R. N. (1982). "Development of a conductivity probe to monitor setting time and moisture movement in concrete," *Cement, Concrete, and Aggregates* 4(2), 73-80.
- Transportation Research Board. (1977). "Consolidation of concrete for pavement, bridge decks, and overlays," Synthesis of Highway Practice (NCHRP-44), National Research Council, National Cooperative Highway Research Program, Washington, DC.
- Waters, E. H. (1952). Discussion of "New techniques in the study of setting and hardening of hydraulic materials," by J. Calleja, *Journal of the American Concrete Institute, Proceedings* 48(2), 536-1 to 536-10.
- White, M. W., and Manning, K. V. (1954). "Experimental college physics." *Measurement of Resistance by Wheatstone's Bridge*. McGraw Hill, New York.
- Whittington, H. W., McCarter, J., and Forde, M. C. (1981). "The conduction of electricity through concrete," *Magazine of Concrete Research* 33(114), 48-60.

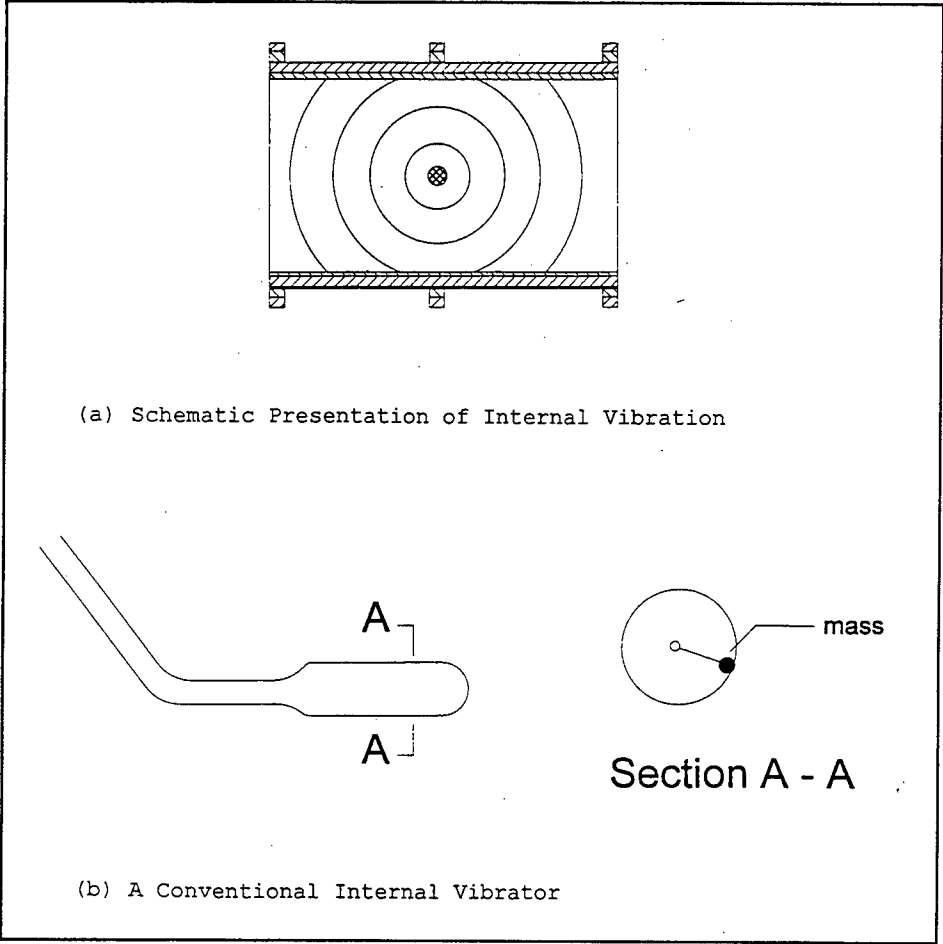

Figure 1. Basic concepts of consolidation through internal vibration

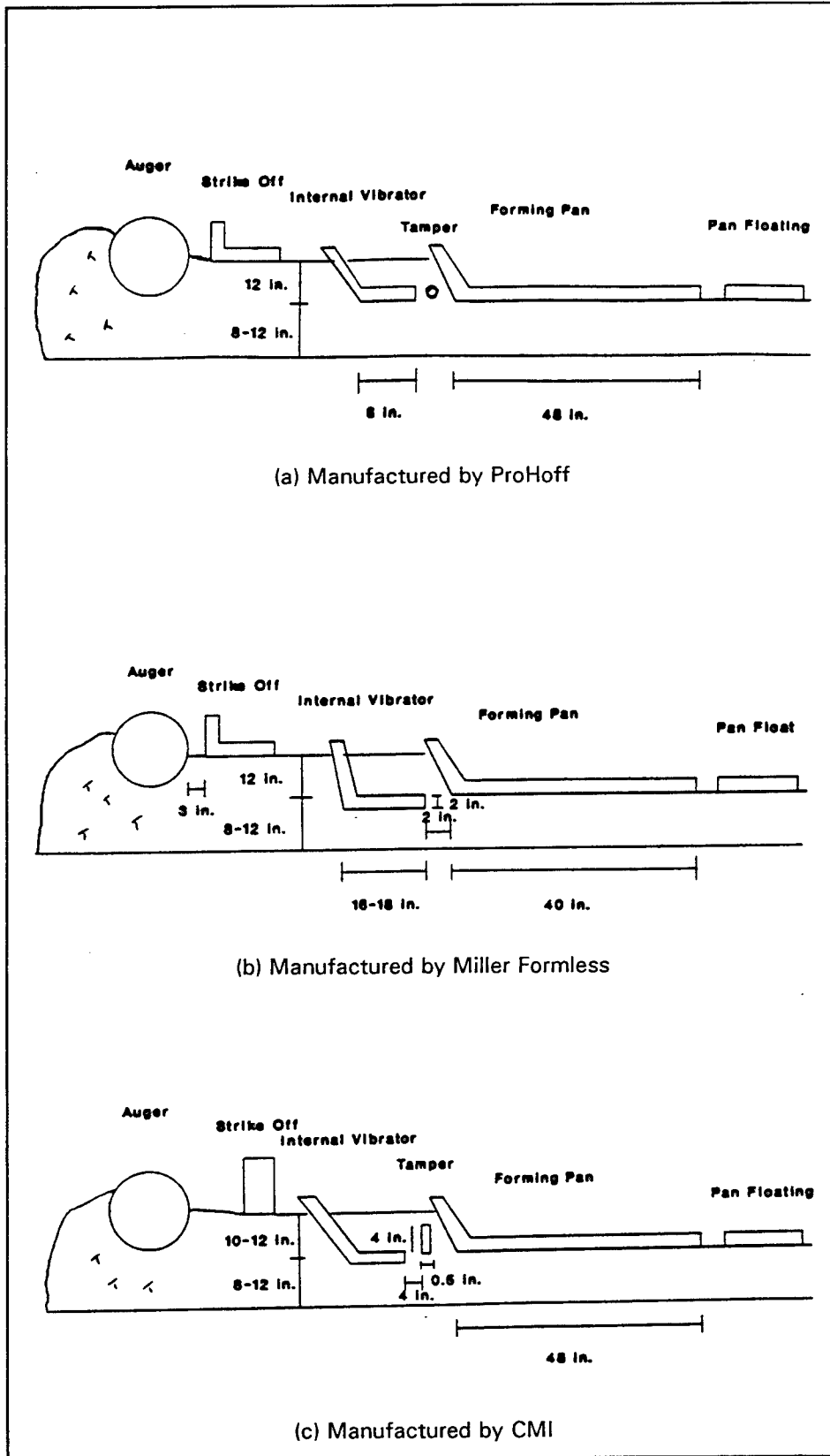
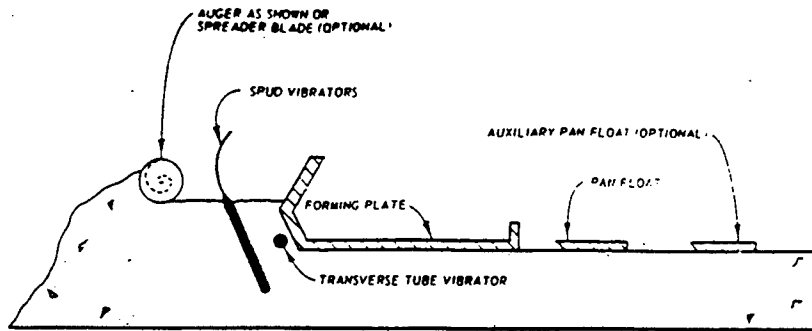
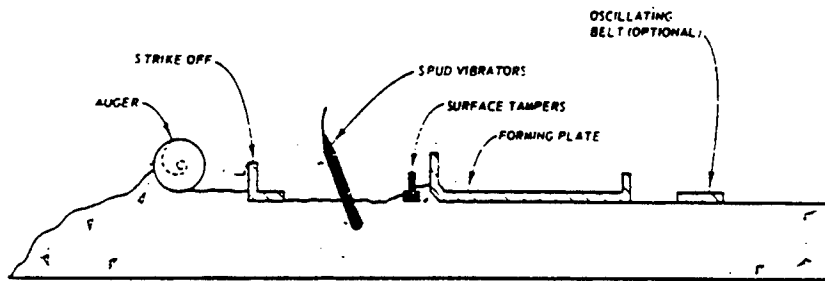

Figure 2. Schematics of slipform paver (Continued)



(d) Manufactured by Zimmerman



(e) Manufactured by Rex

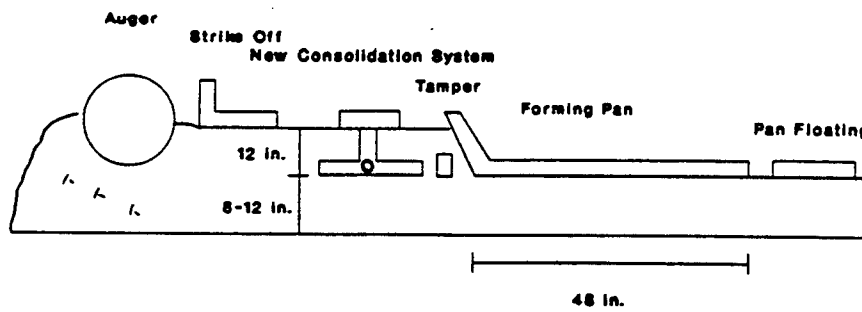

(f) Scheme for the New Consolidation System

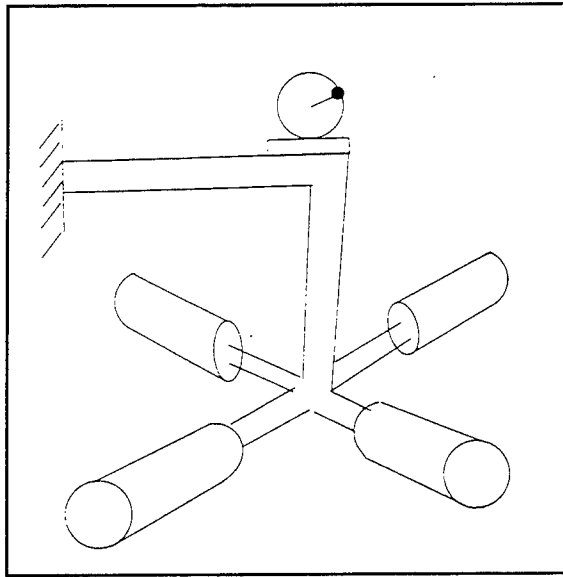

Figure 3. Schematic of new consolidation system

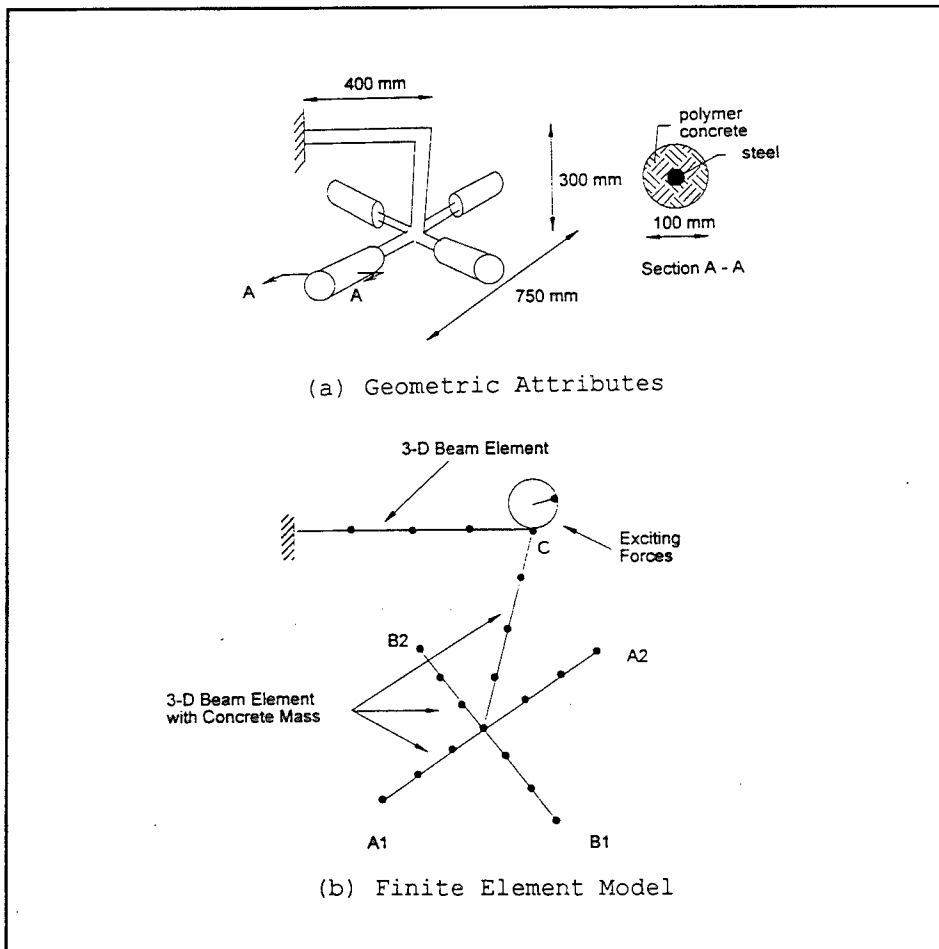

Figure 4. Geometric characteristics and finite-element modeling of system

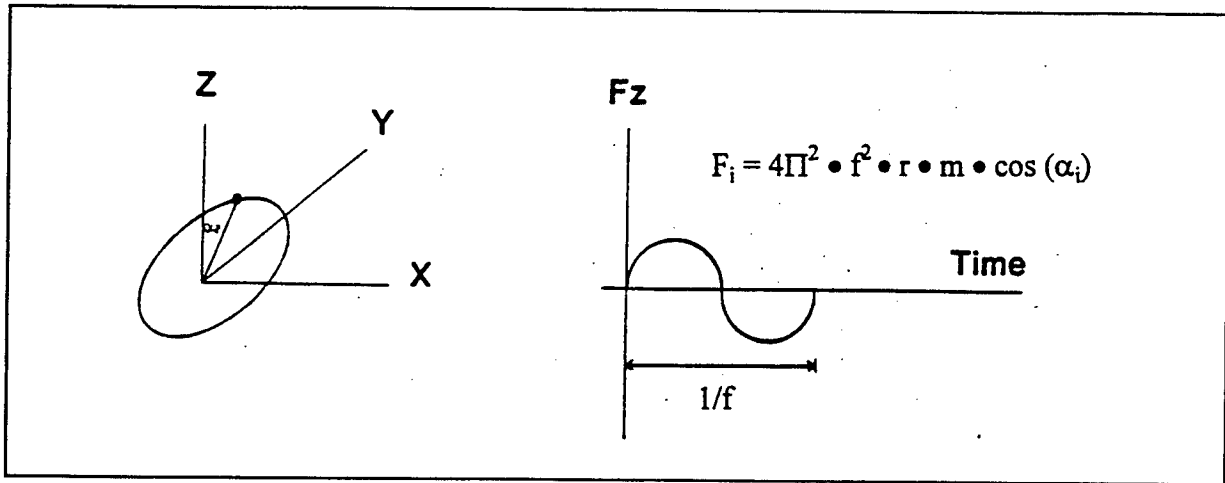

Figure 5. Rotary mass effects

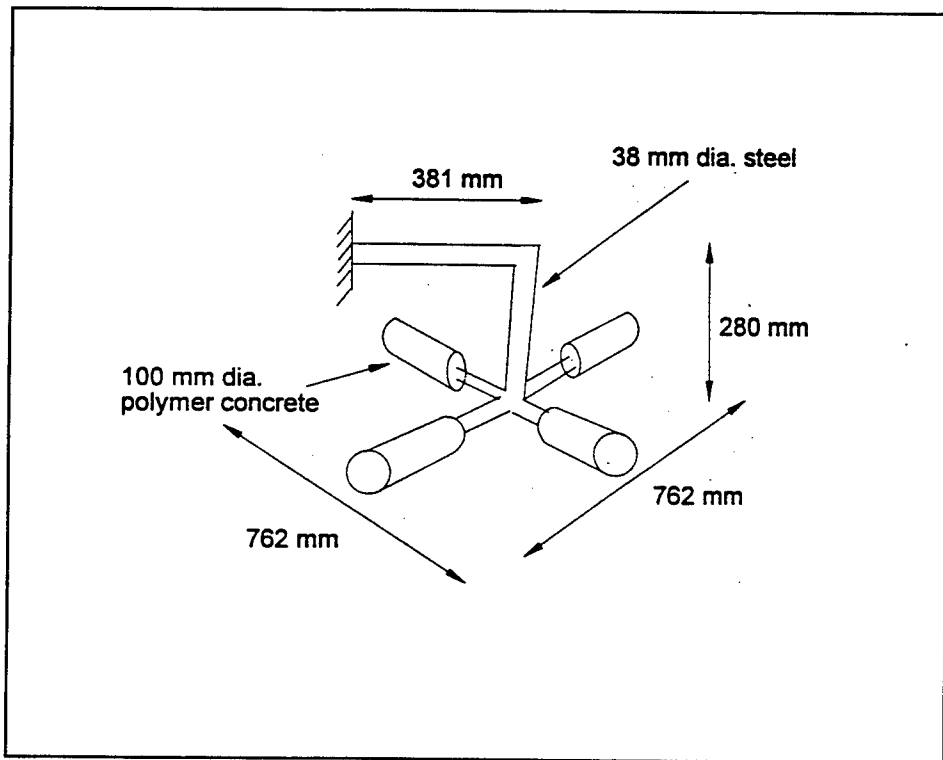

Figure 6. Final system design

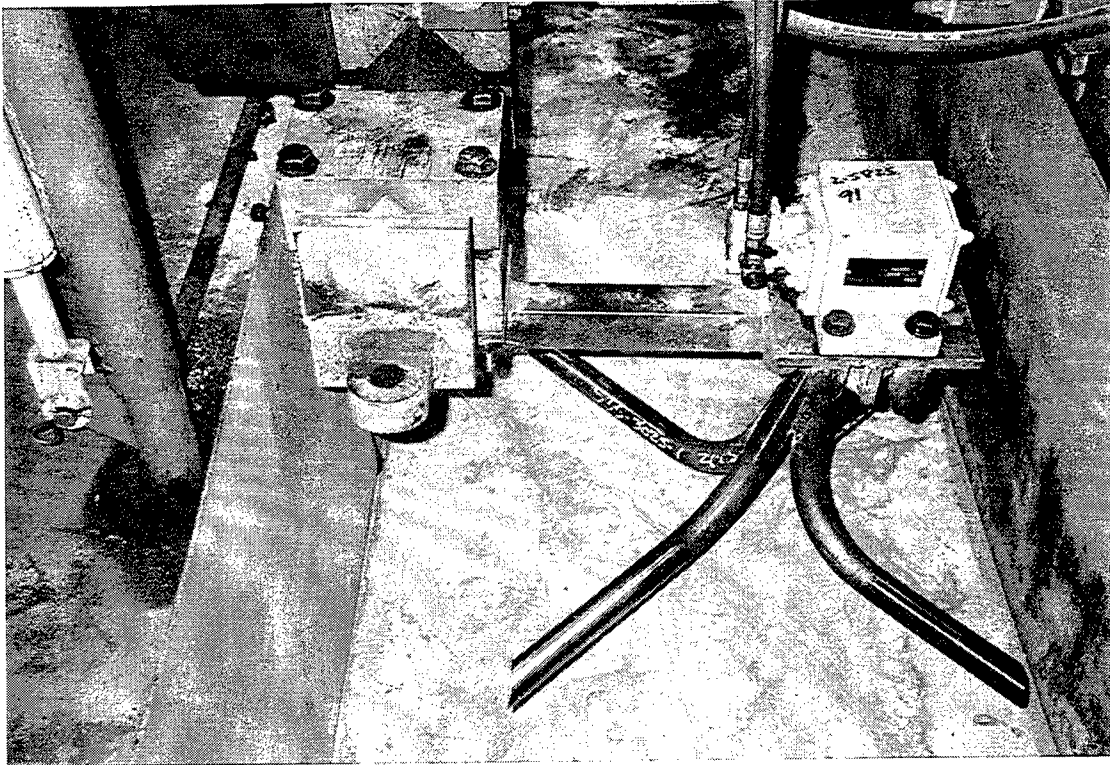

Figure 7. Typical prototype system

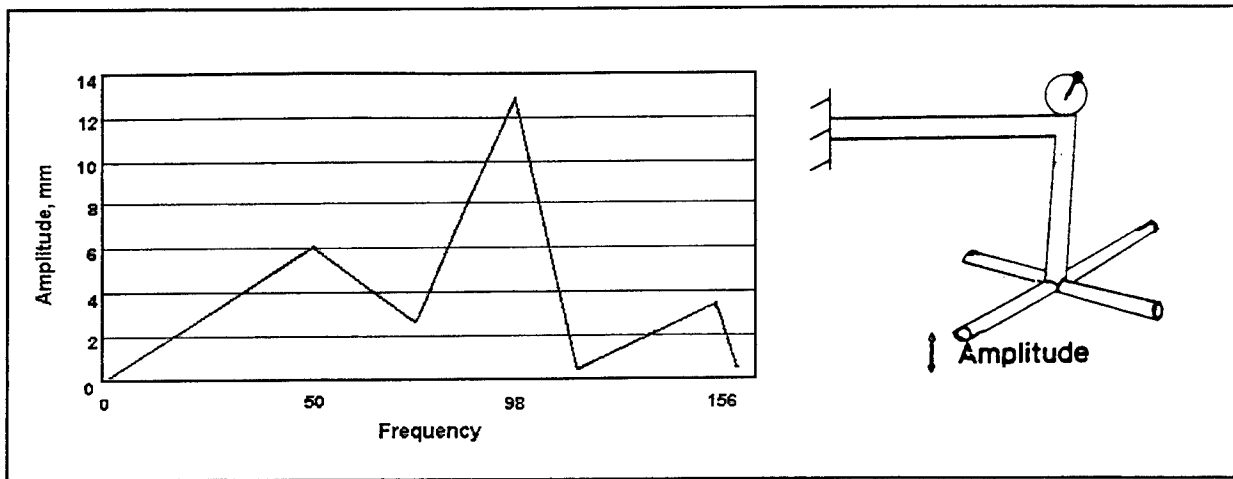

Figure 8. Vibratory amplitude versus frequency

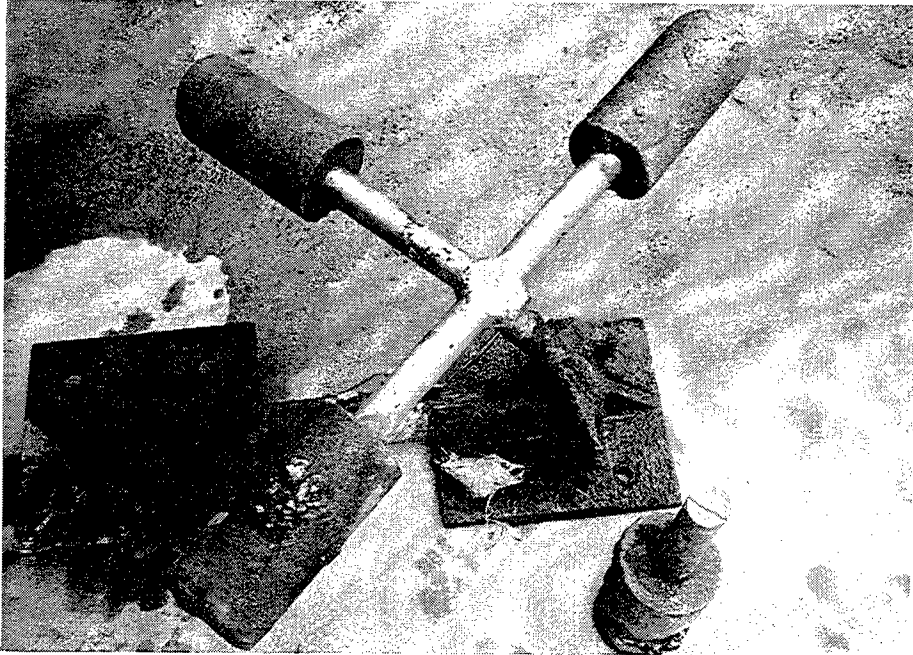

Figure 9. Example of fatigue failure

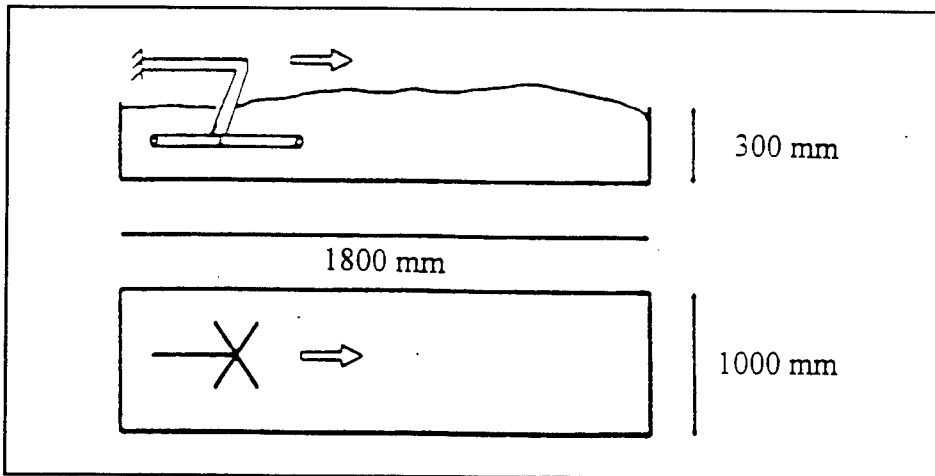
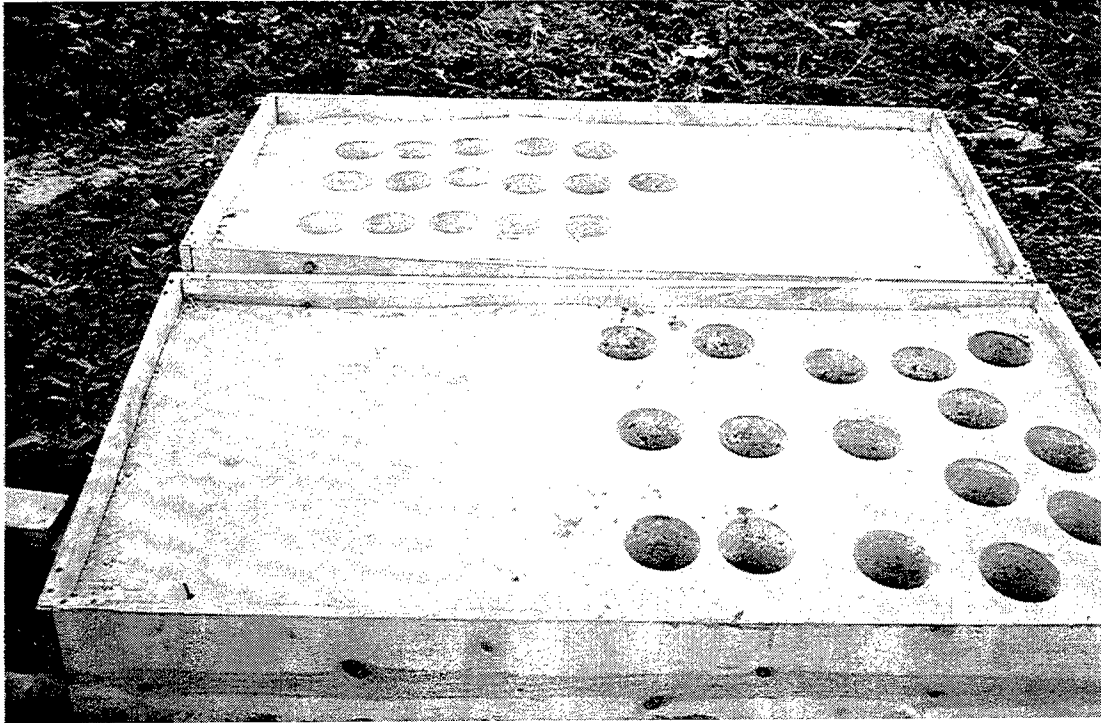
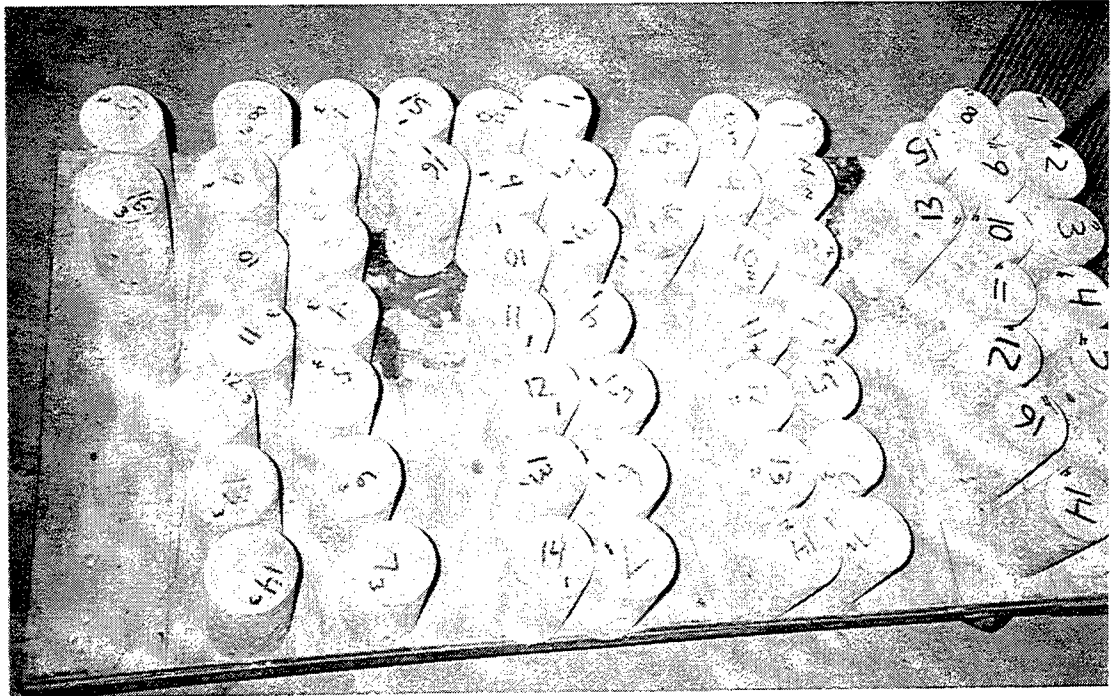

Figure 10. Laboratory test setup for evaluation of consolidation system



(a) Cored slabs



(b) Cored samples

Figure 11. Core samples obtained from consolidated slabs

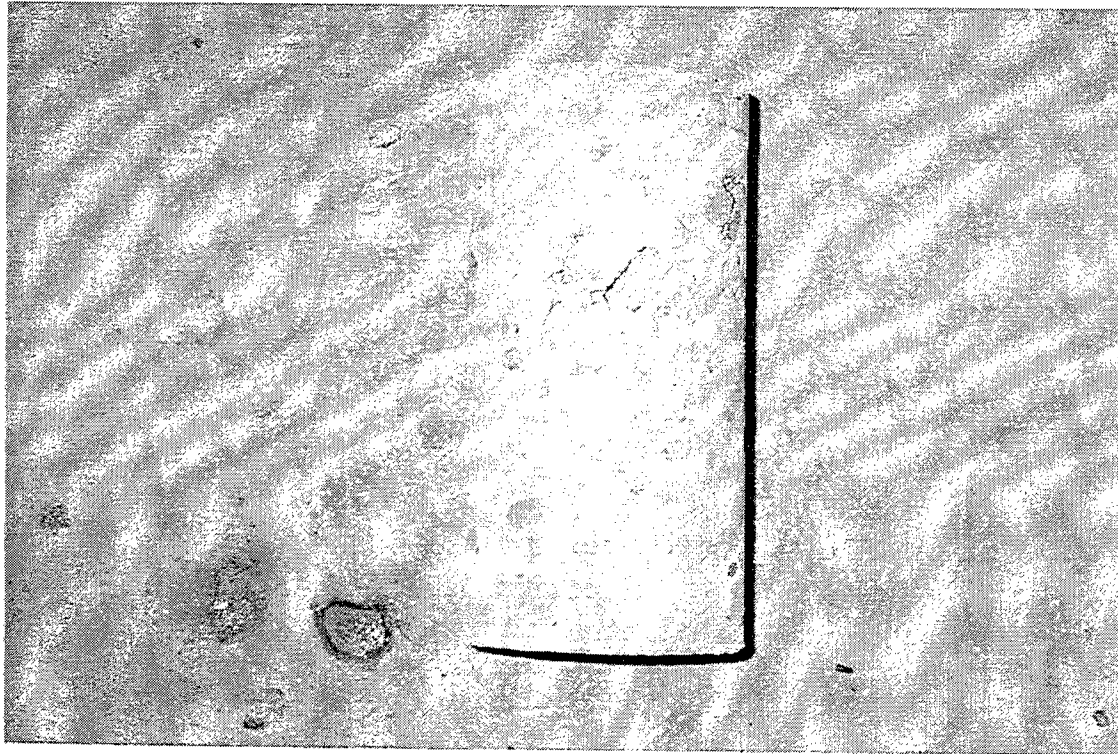

(a) Excellent (prototype system)

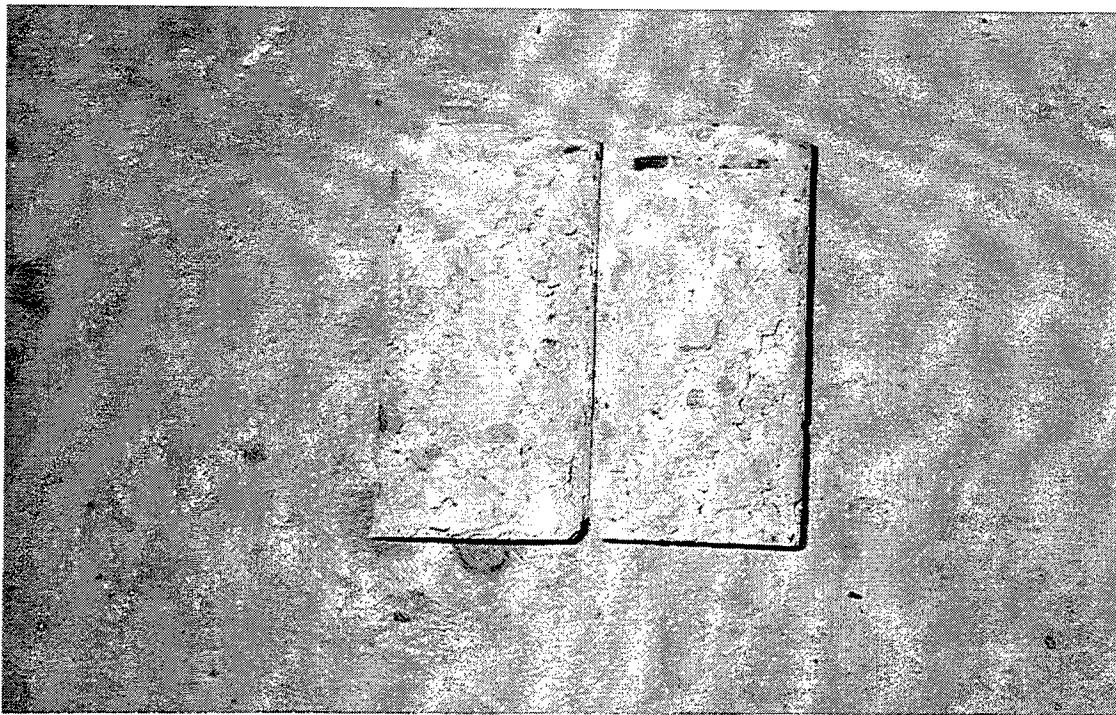

(b) Poor (conventional system)

Figure 12. Visual assessment of consolidation condition

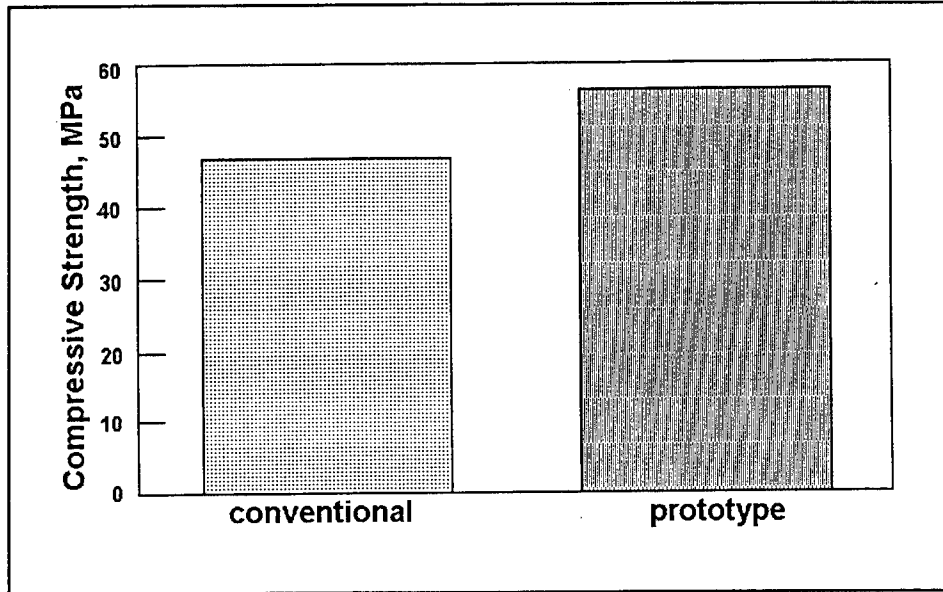

Figure 13. Compressive-strength test results

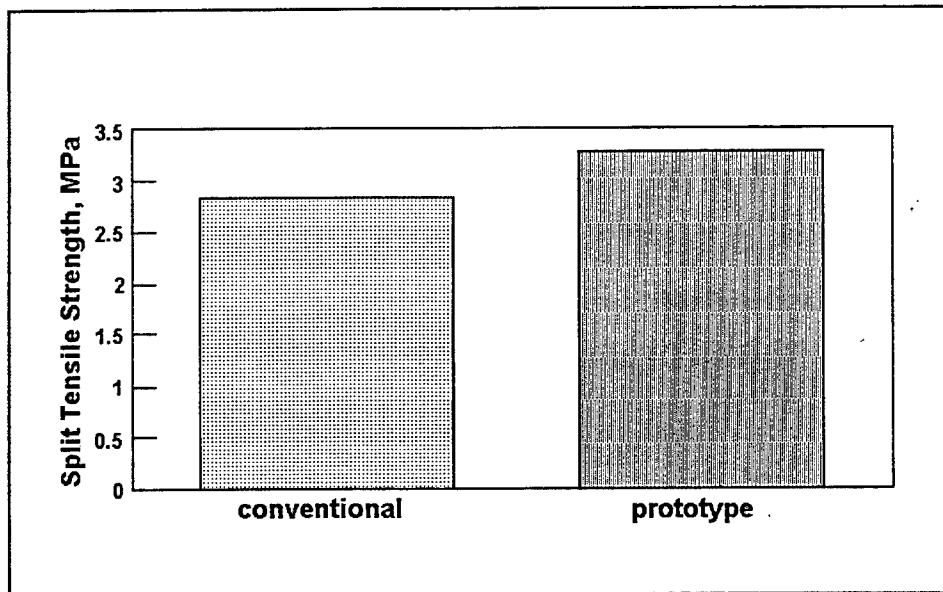
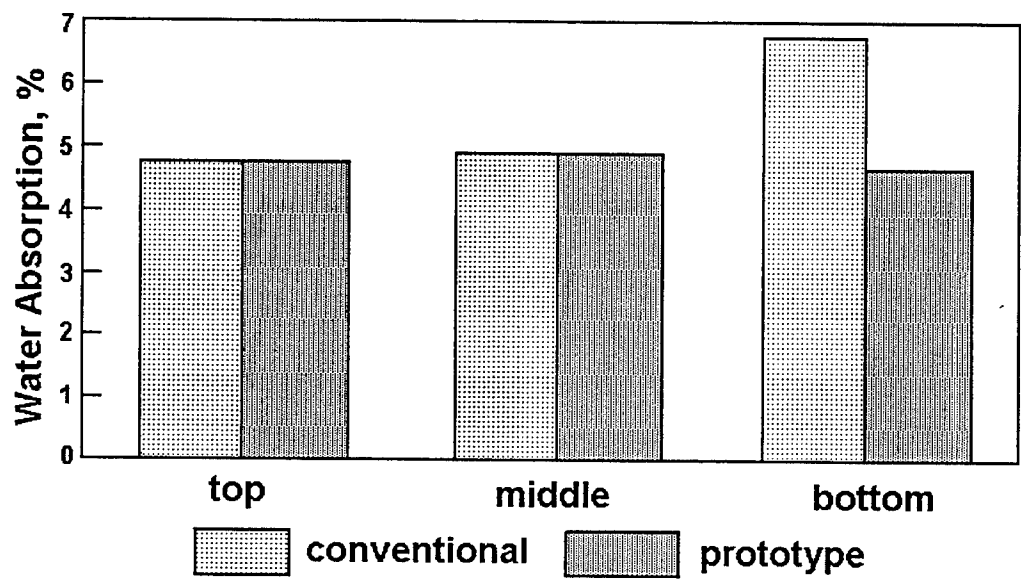
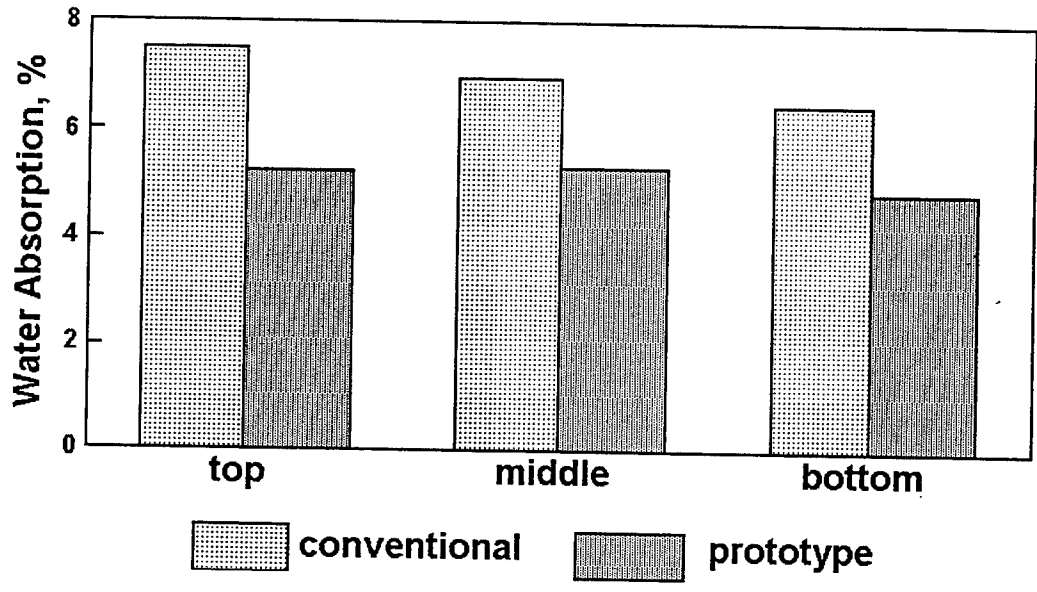

Figure 14. Splitting-tensile-strength test results



a. Along the center line



b. On the side

Figure 15. Water absorption test results

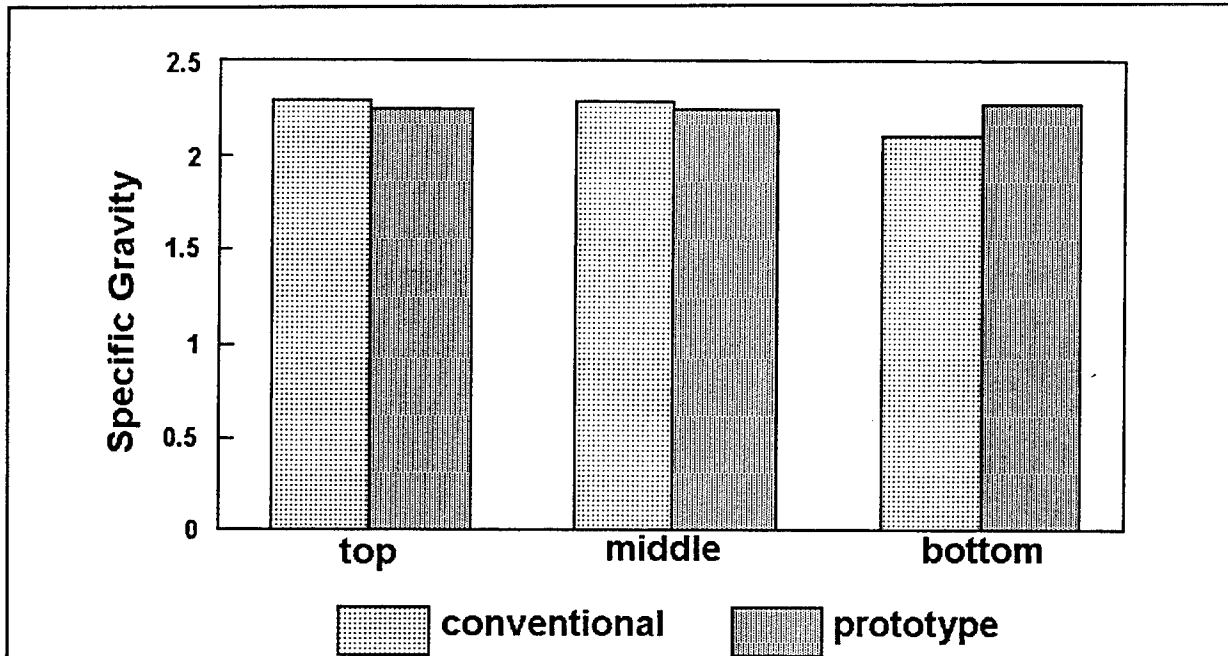

a. Along the center line

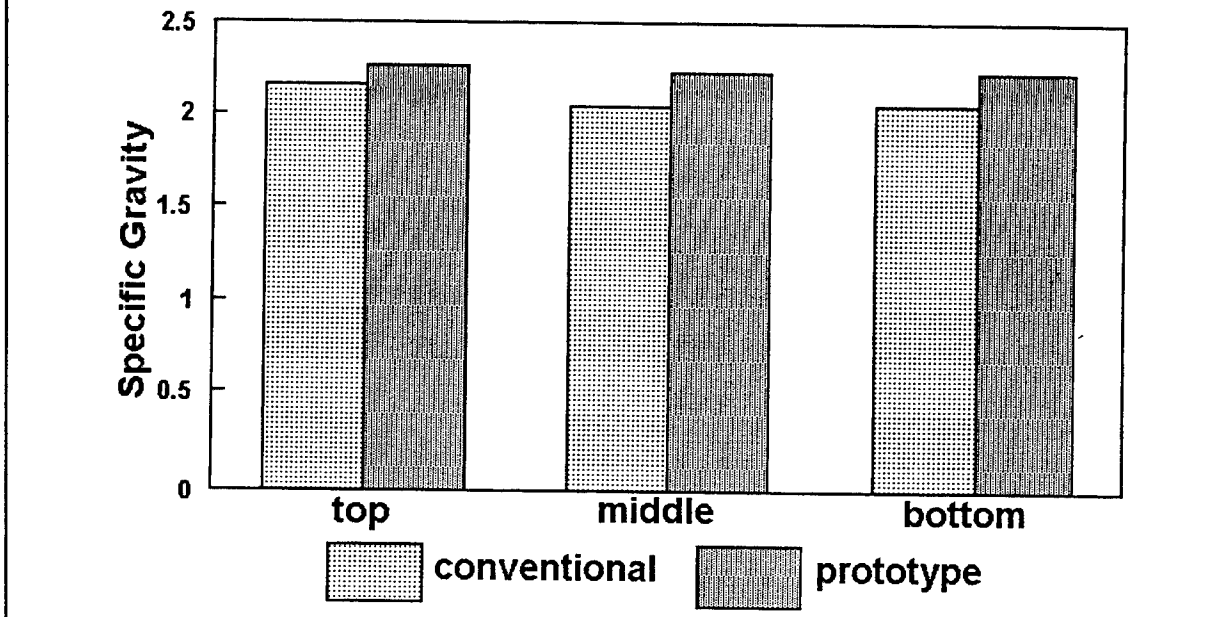

b. On the side

Figure 16. Unit weight test results

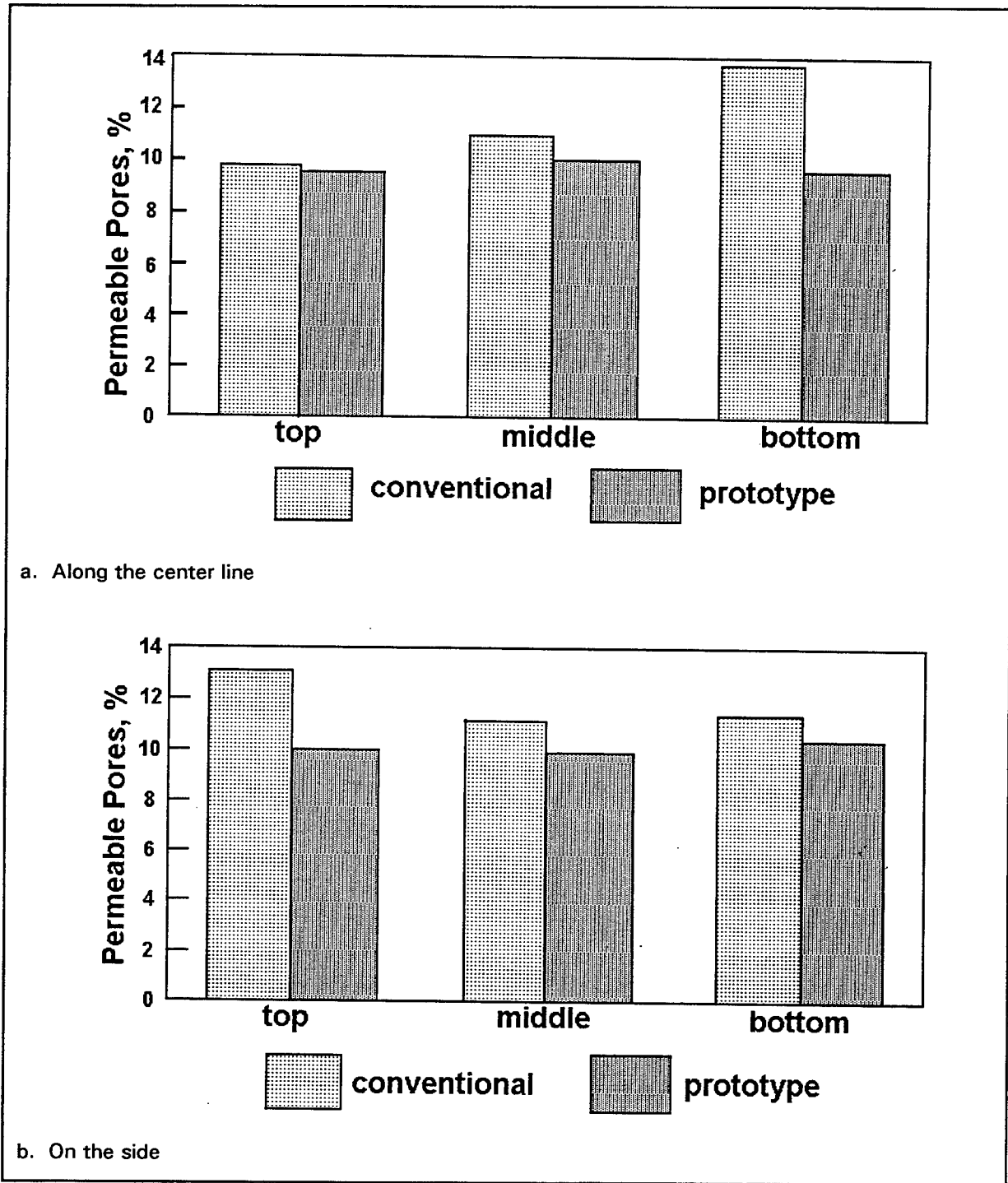

Figure 17. Volume of permeable pores test results

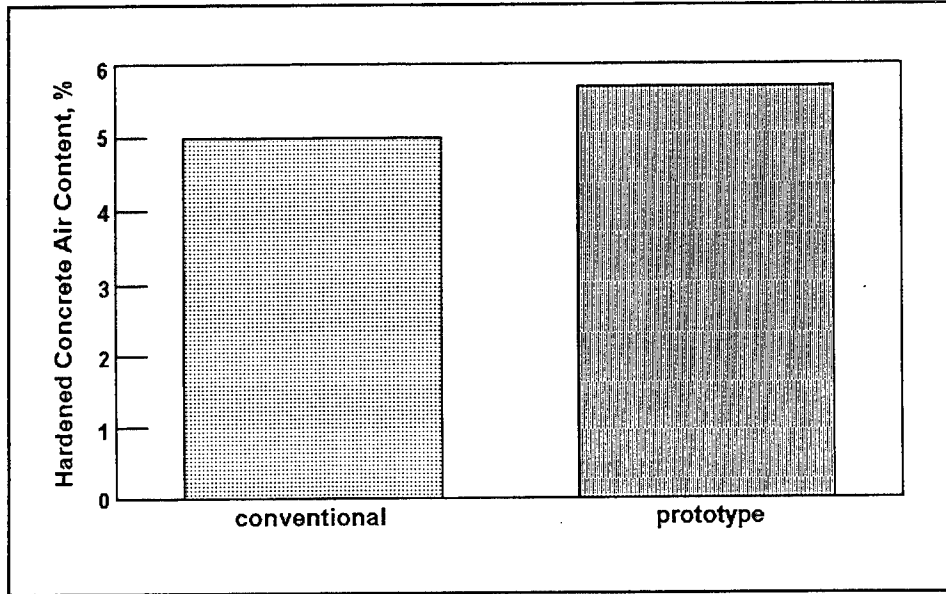

Figure 18. Air contents obtained by linear-traverse test

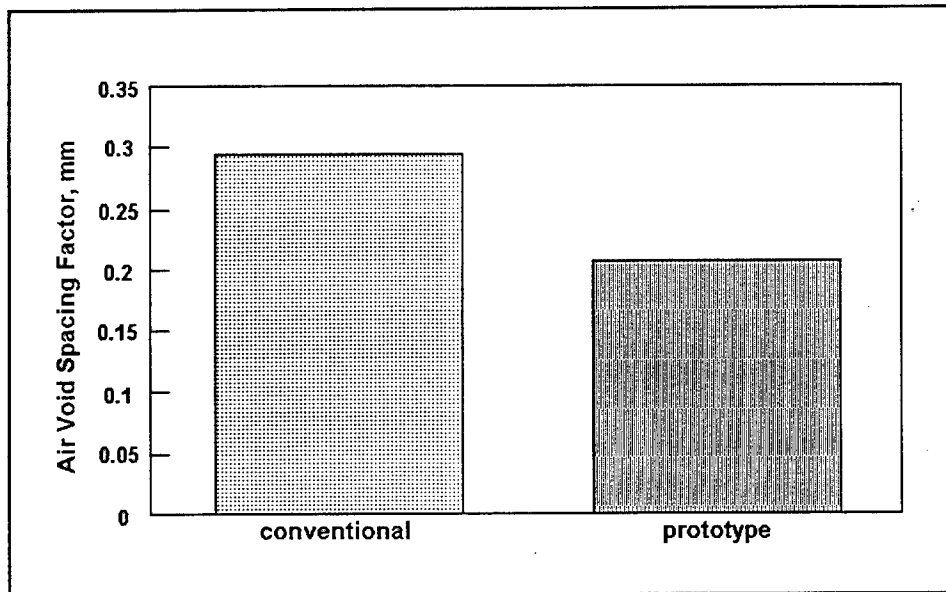

Figure 19. Air-void spacings obtained by linear-traverse test

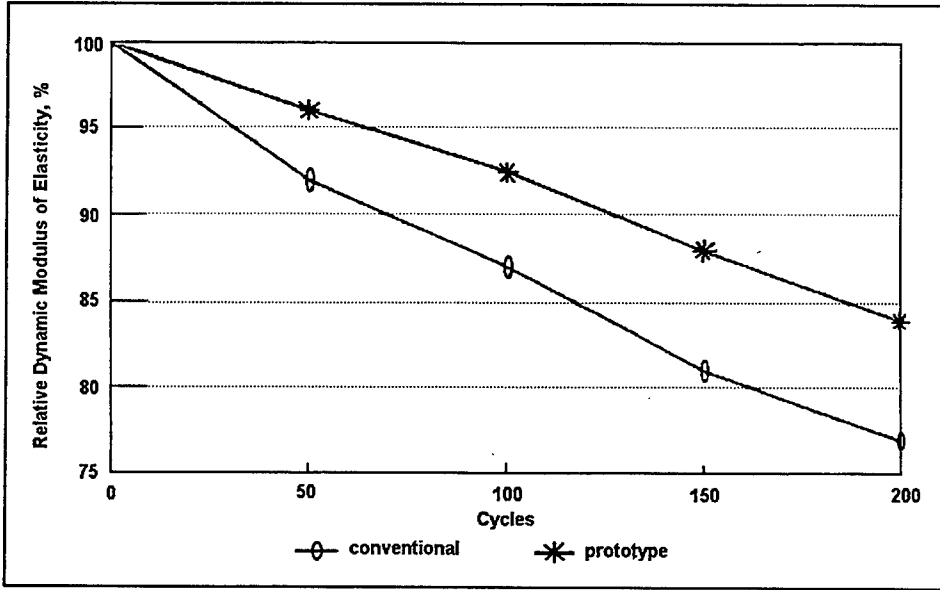

Figure 20. Freezing-and-thawing durability test results

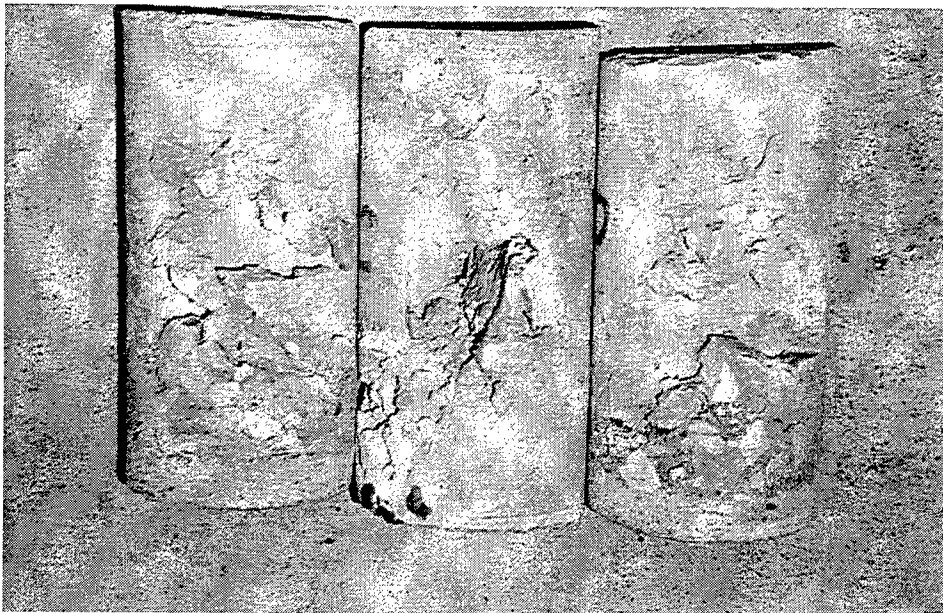

Figure 21. Cores consolidated with conventional vibrator

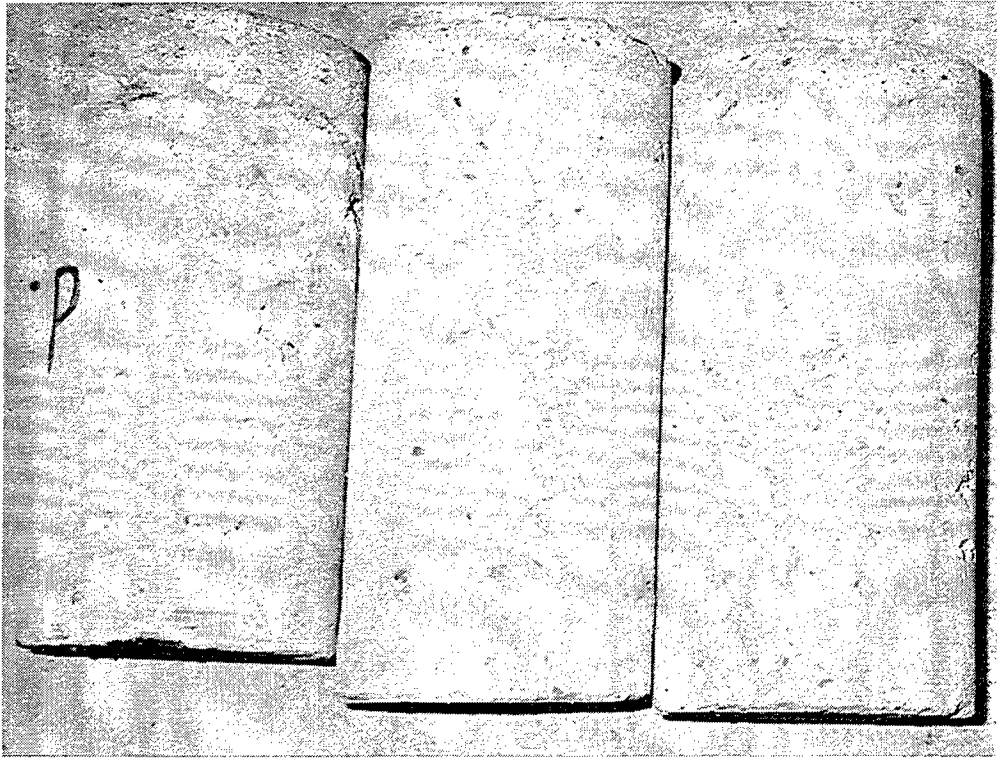

Figure 22. Cores consolidated with final version of new system

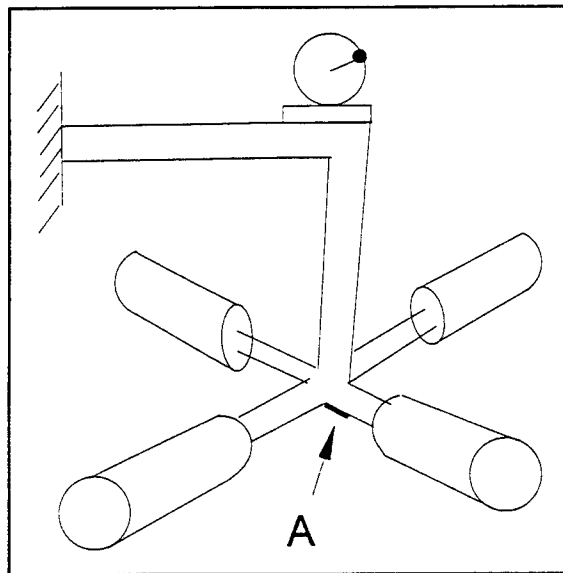

Figure 23. Strain gauge location on system

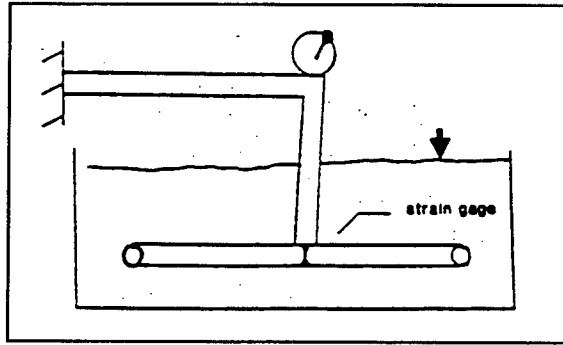

Figure 24. Settlement test setup

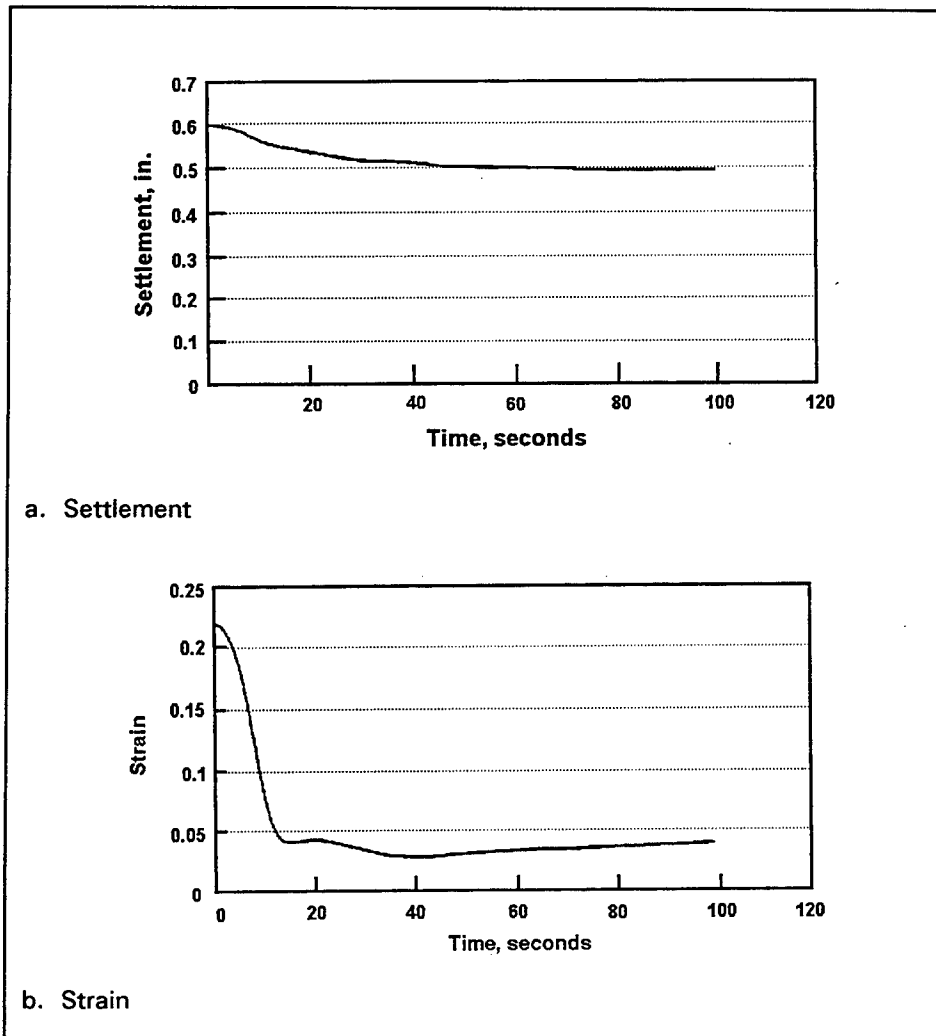
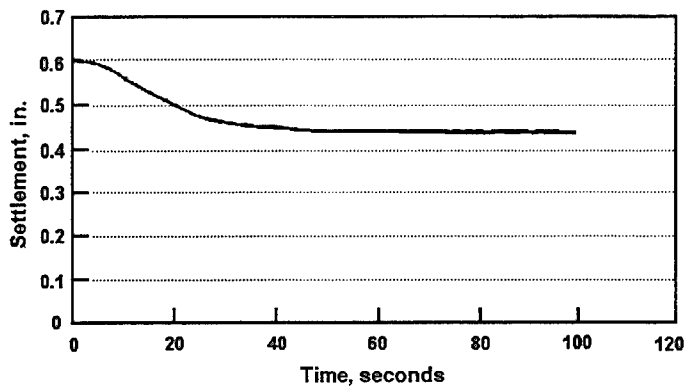
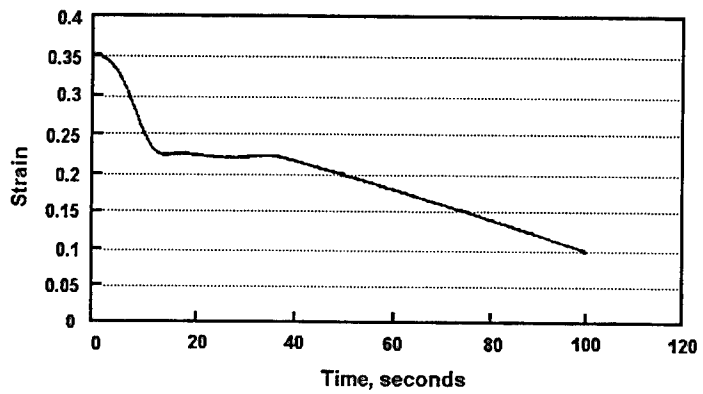

Figure 25. Settlement and strain gauge readings at 110-Hz vibration frequency (1 in. = 25.4 mm)



a. Settlement



b. Strain

Figure 26. Settlement and strain gauge reading at 120-Hz vibration frequency (1 in. = 25.4 mm)

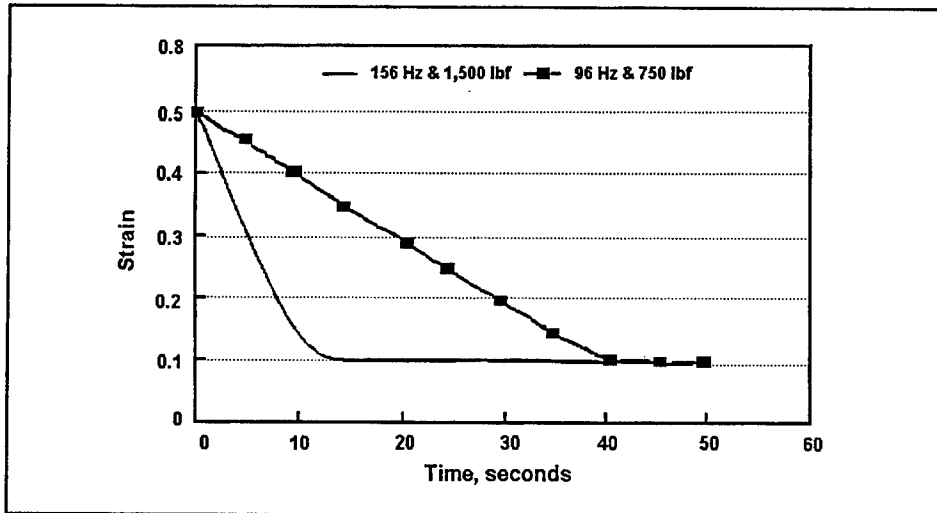

Figure 27. Effects of operation at two different resonant frequencies on consolidation process

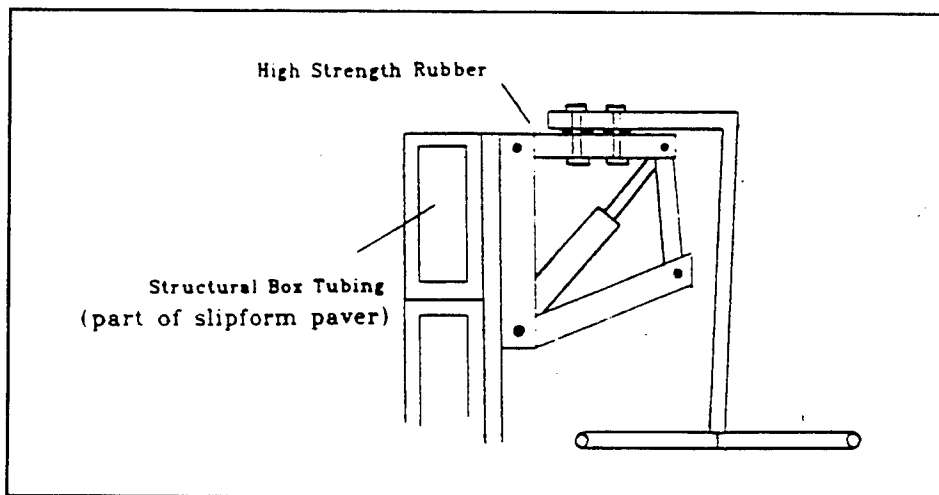

Figure 28. Schematic presentation of connection mechanism

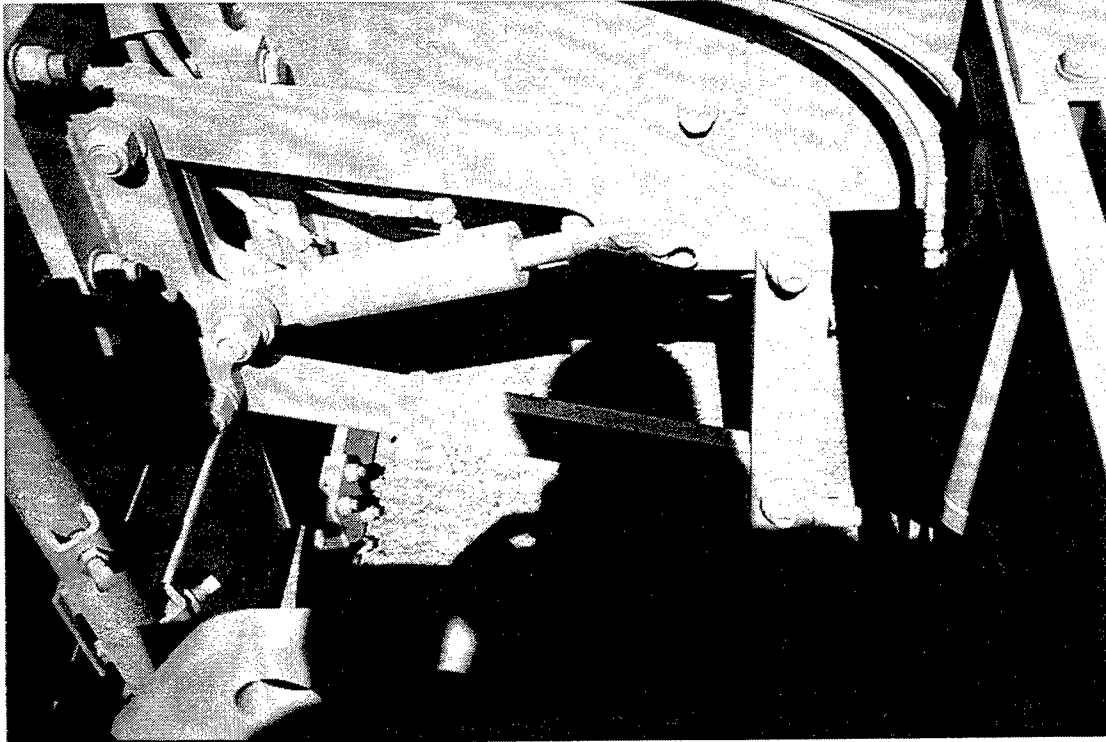

Figure 29. Connection mechanism

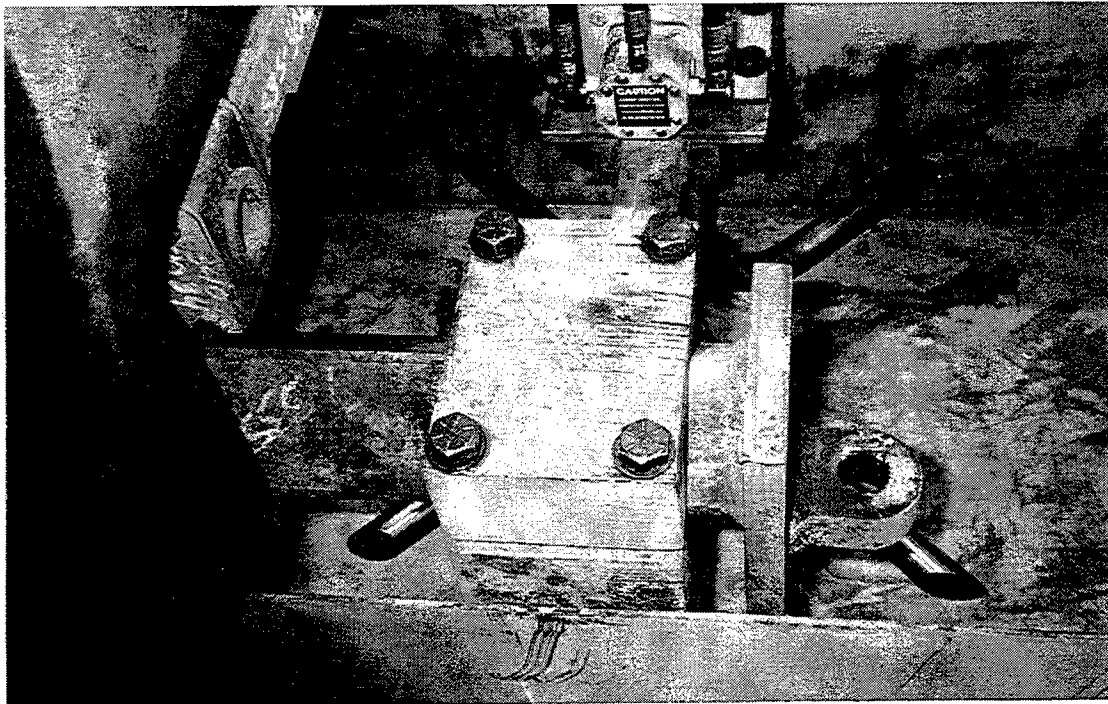

Figure 30. Rigid bar for mounting mechanism onto slipform pavers

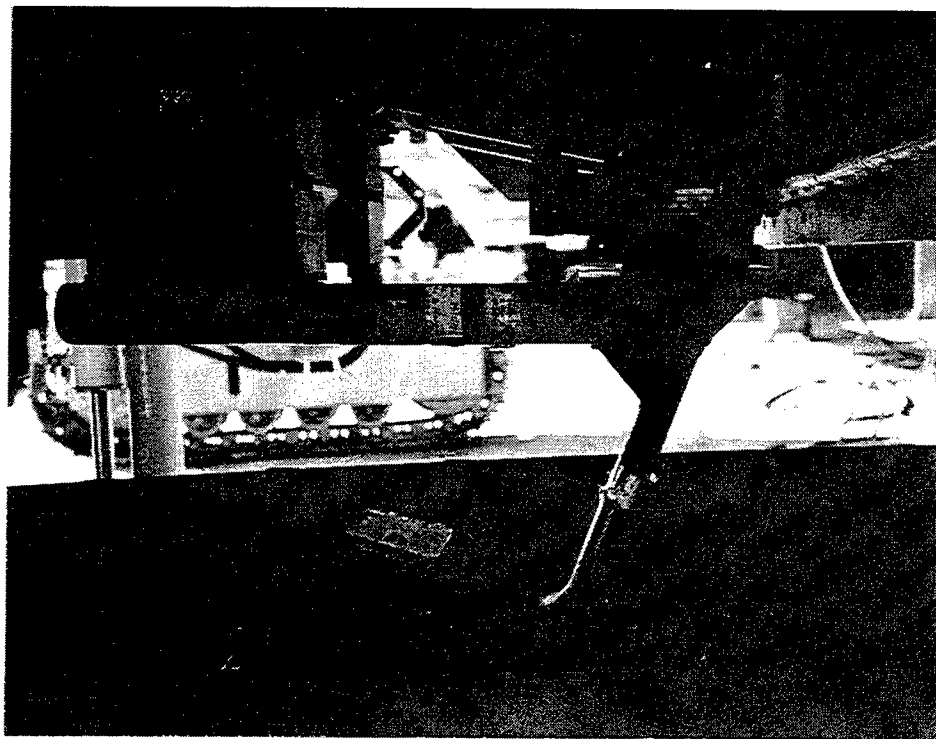

Figure 31. Complete connection system

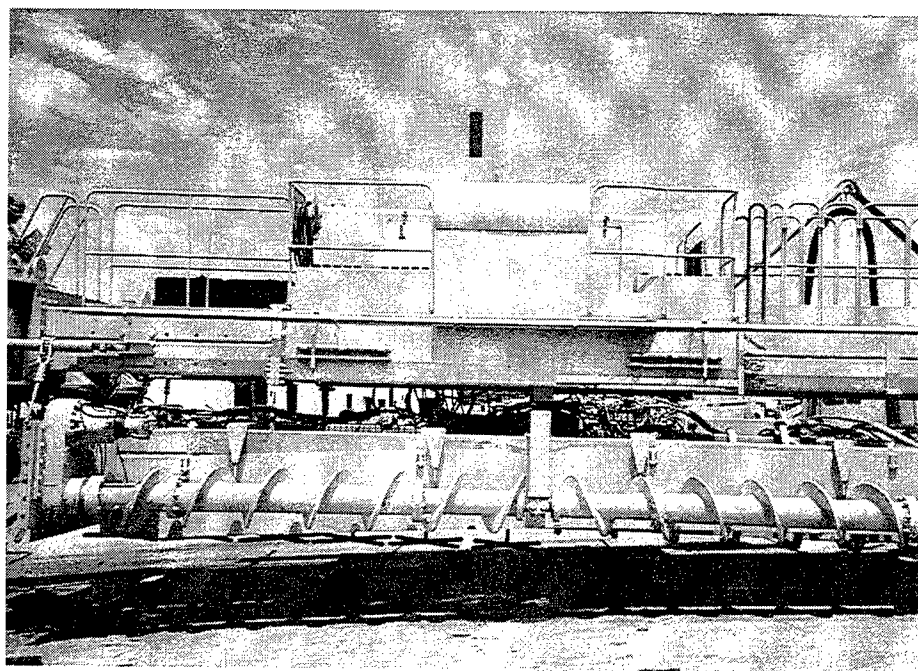

Figure 32. Overall view of slipform paver incorporating new RV system

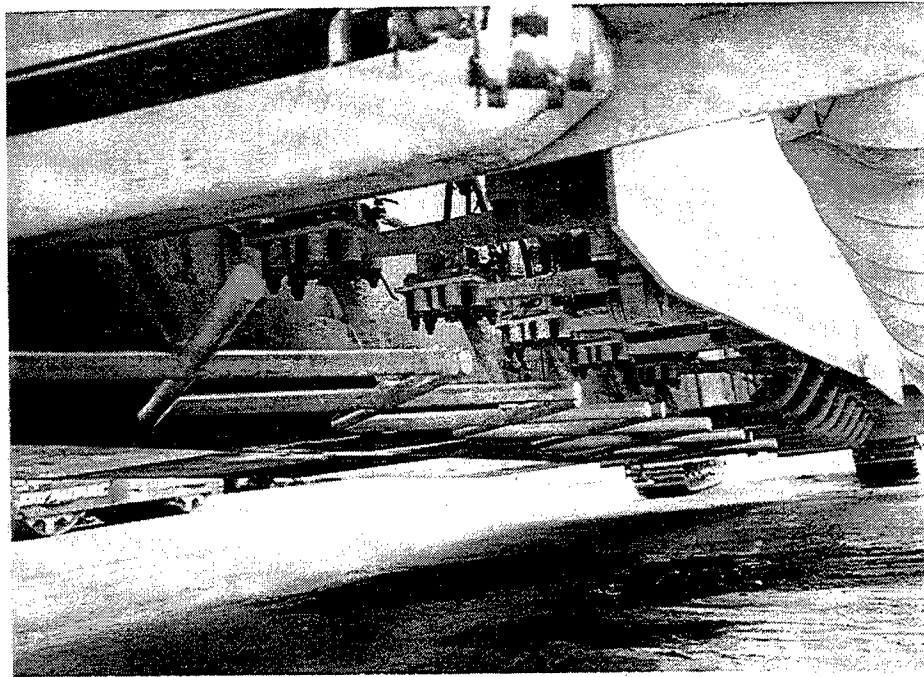

Figure 33. Close view of RV installed in grout box of slipform paver

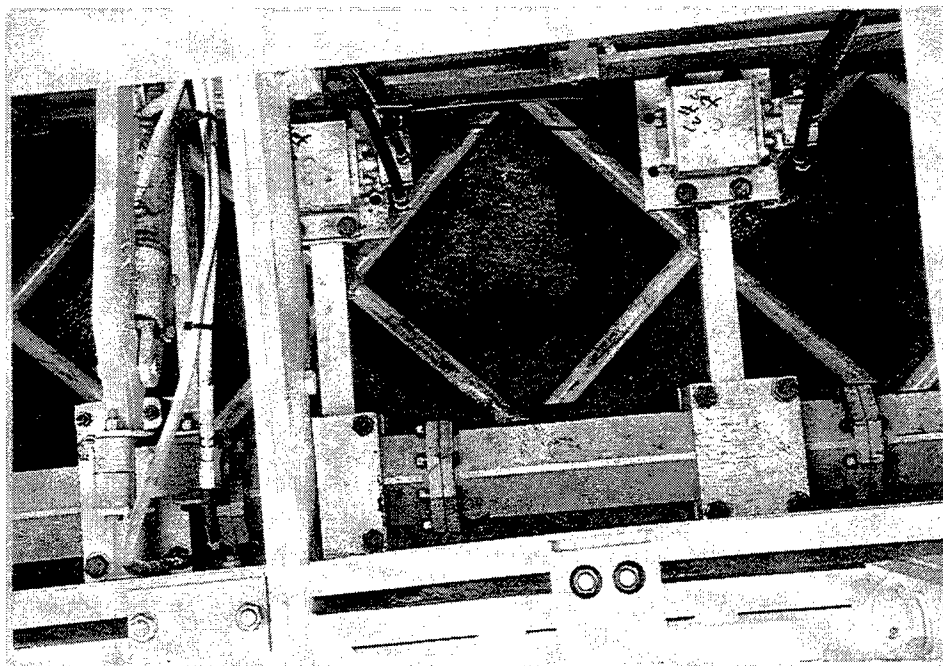

Figure 34. Rigid bar interfacing new RV system to slipform paver

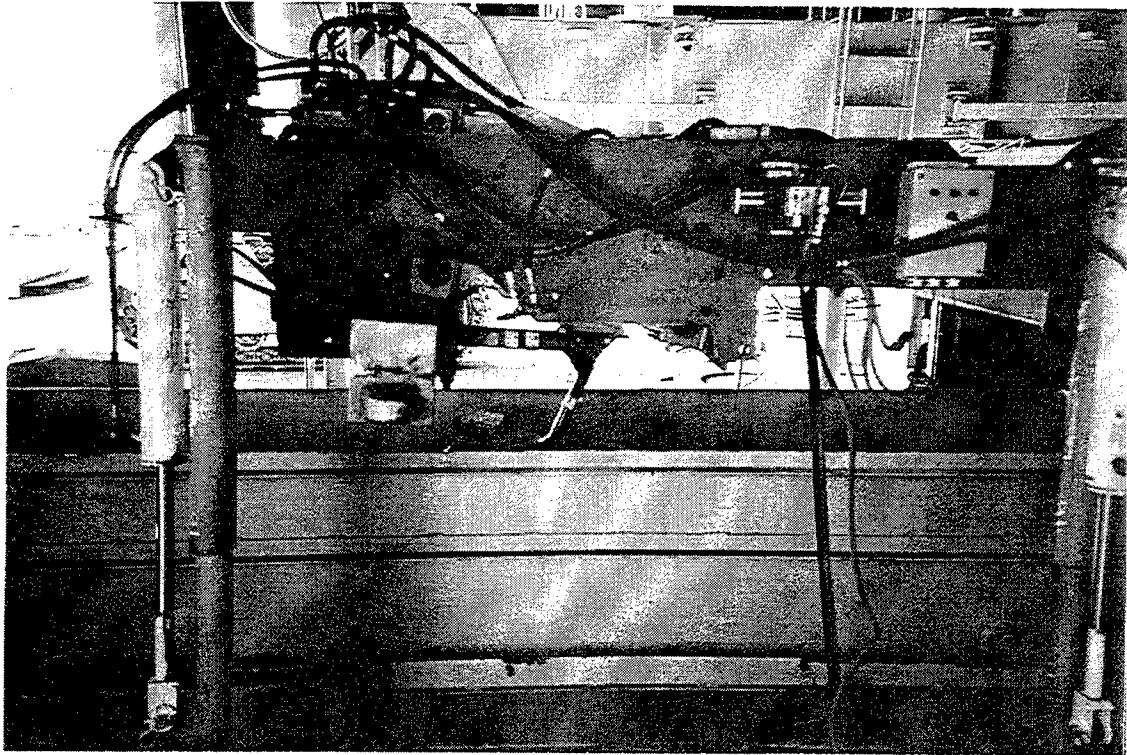

Figure 35. Overall view of large-scale setup

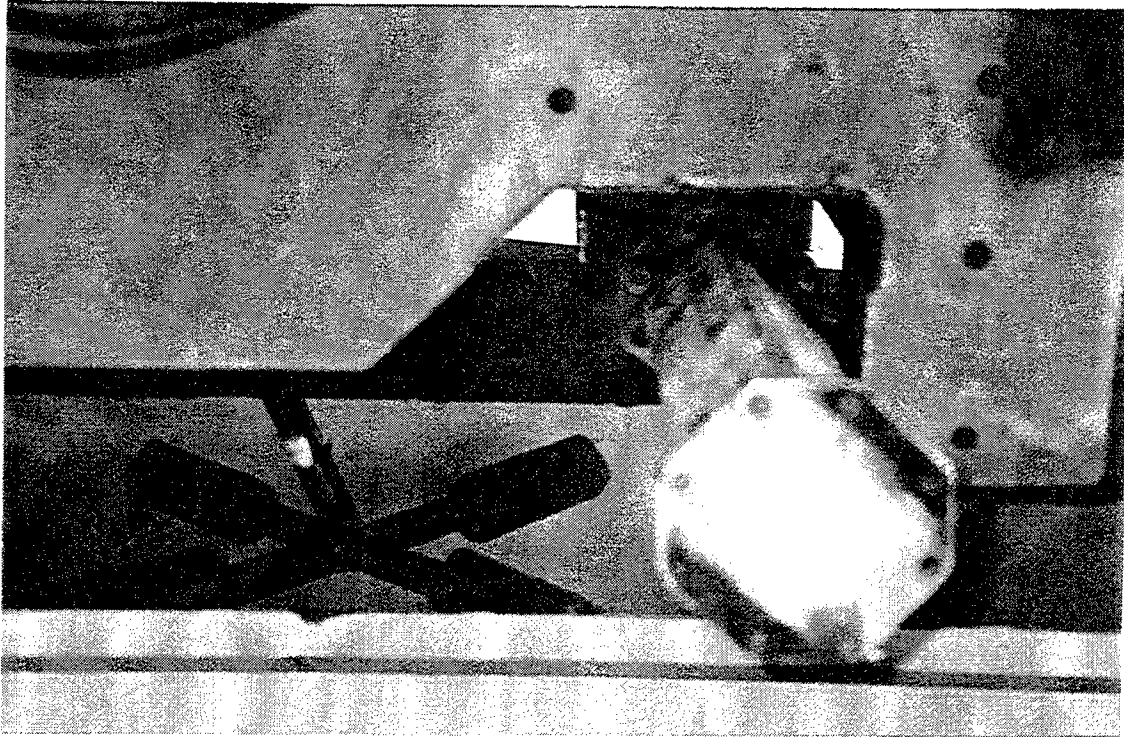

Figure 36. Connection-support system

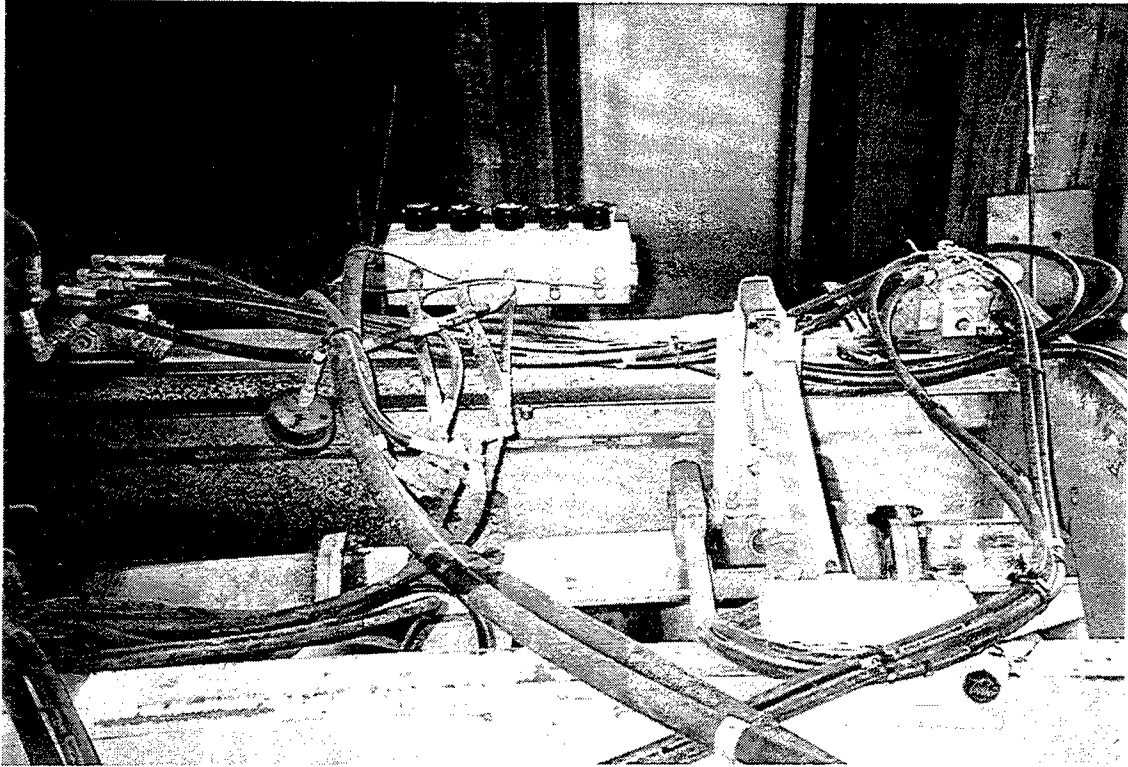

Figure 37. Vertical movement mechanism

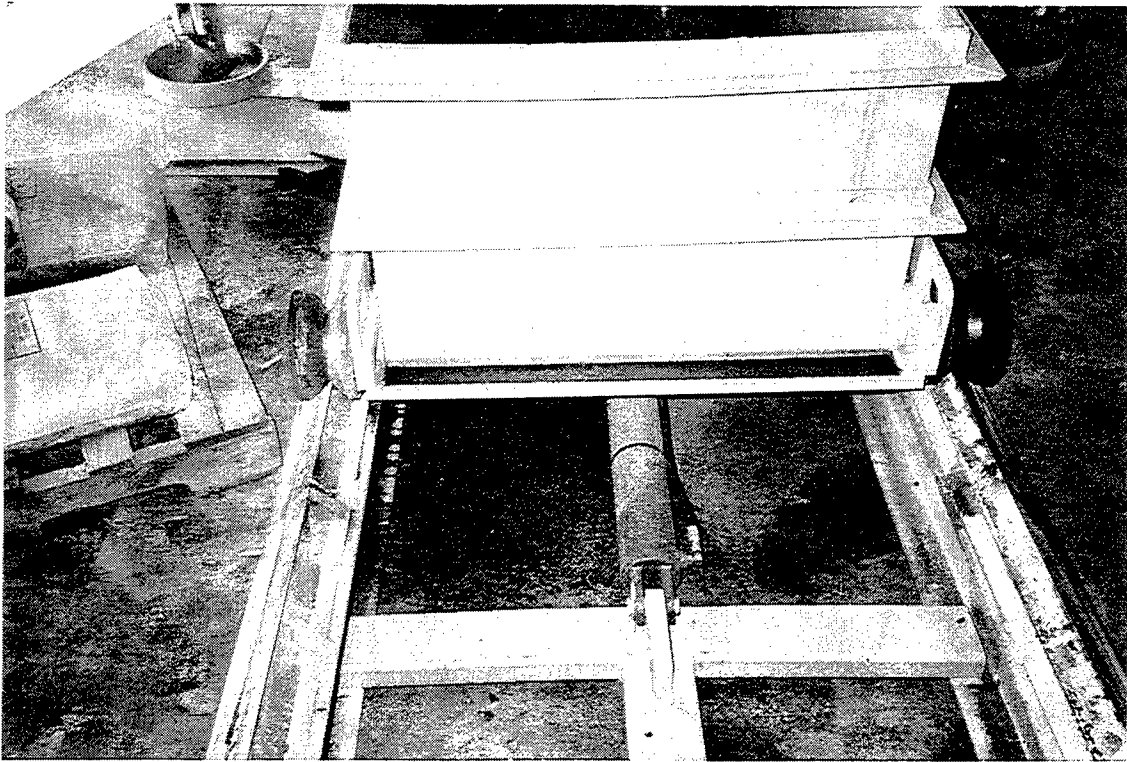

Figure 38. Horizontal movement mechanism

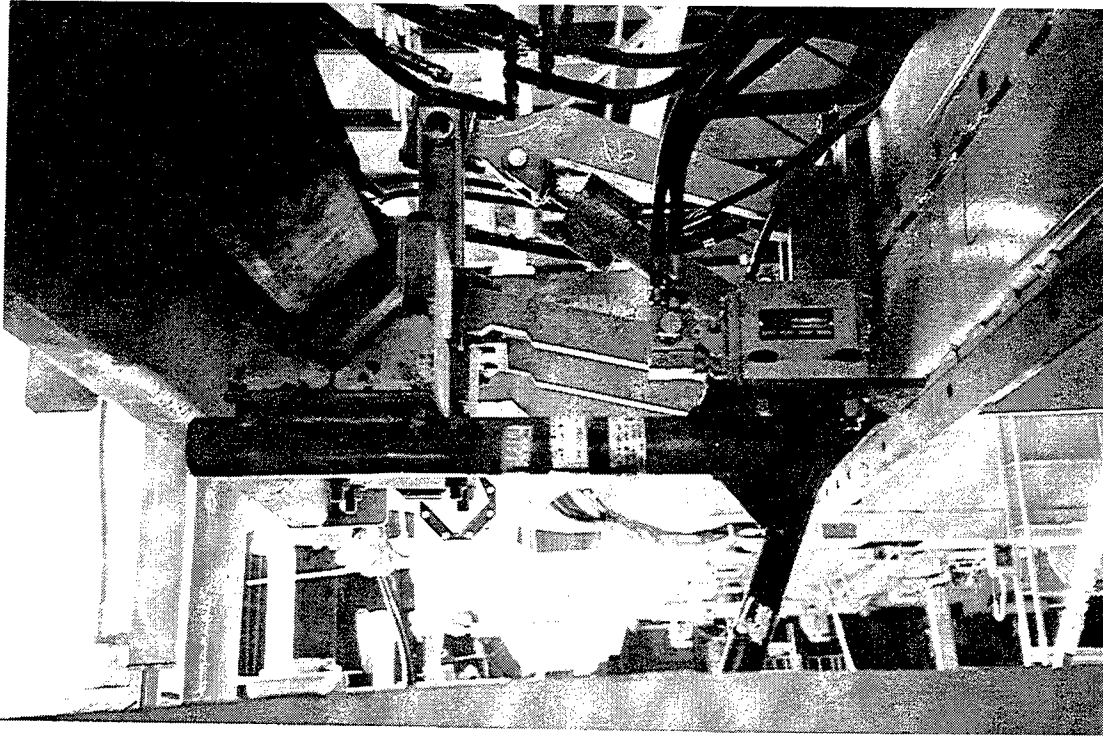

Figure 39. Hydraulic systems

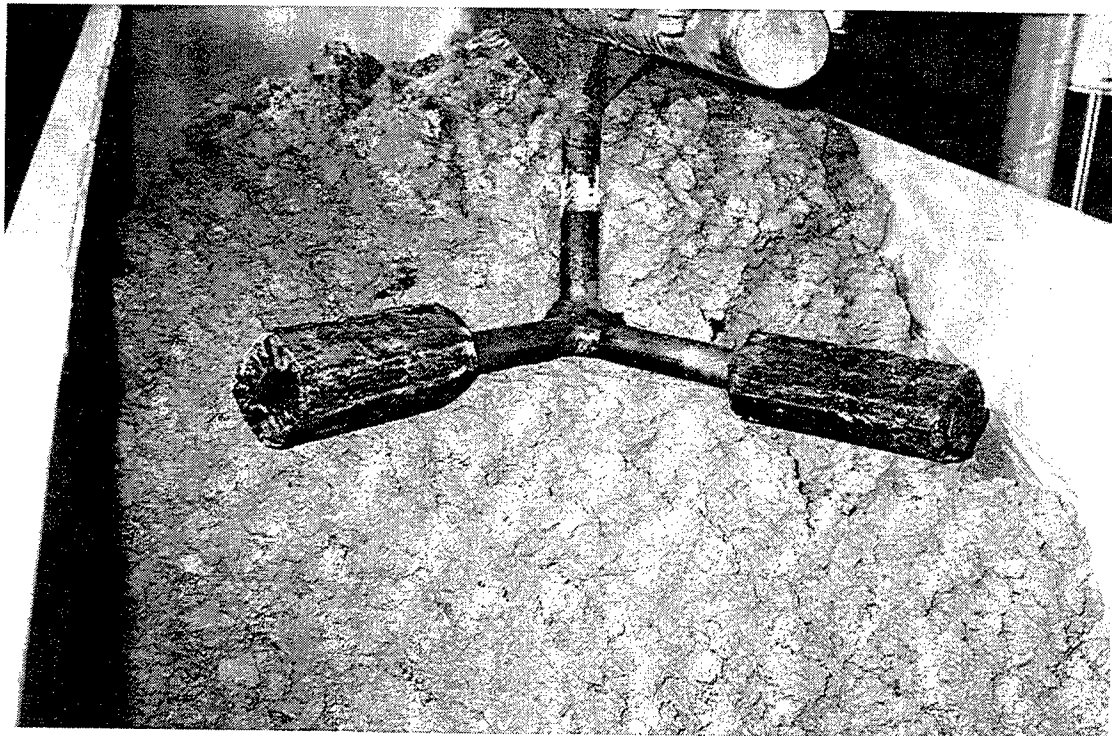

Figure 40. Placement of concrete

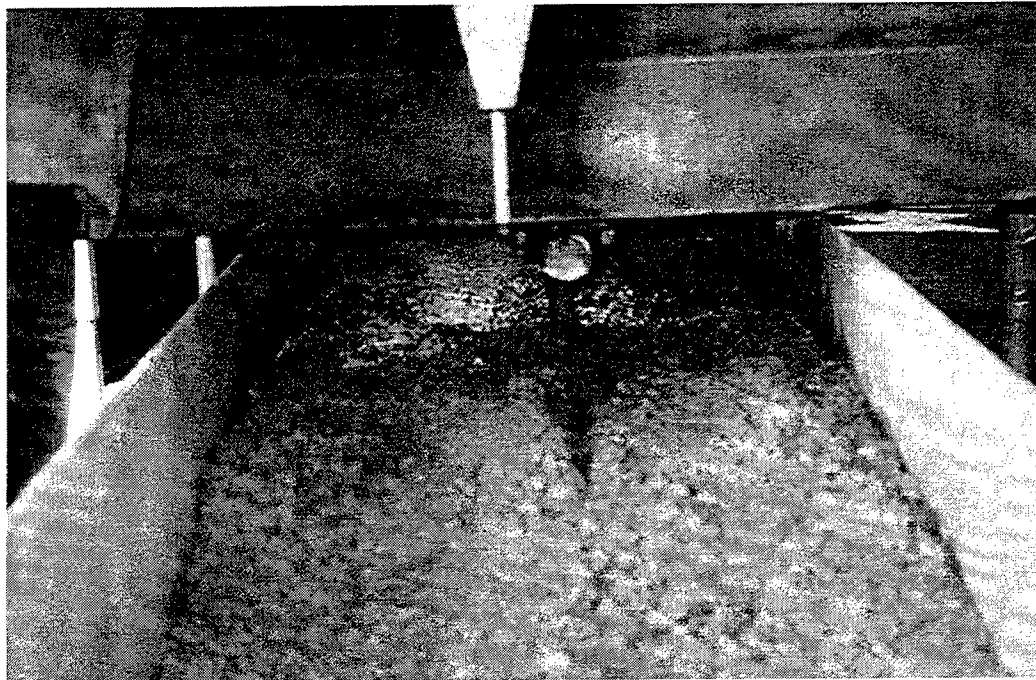

Figure 41. Operation of system

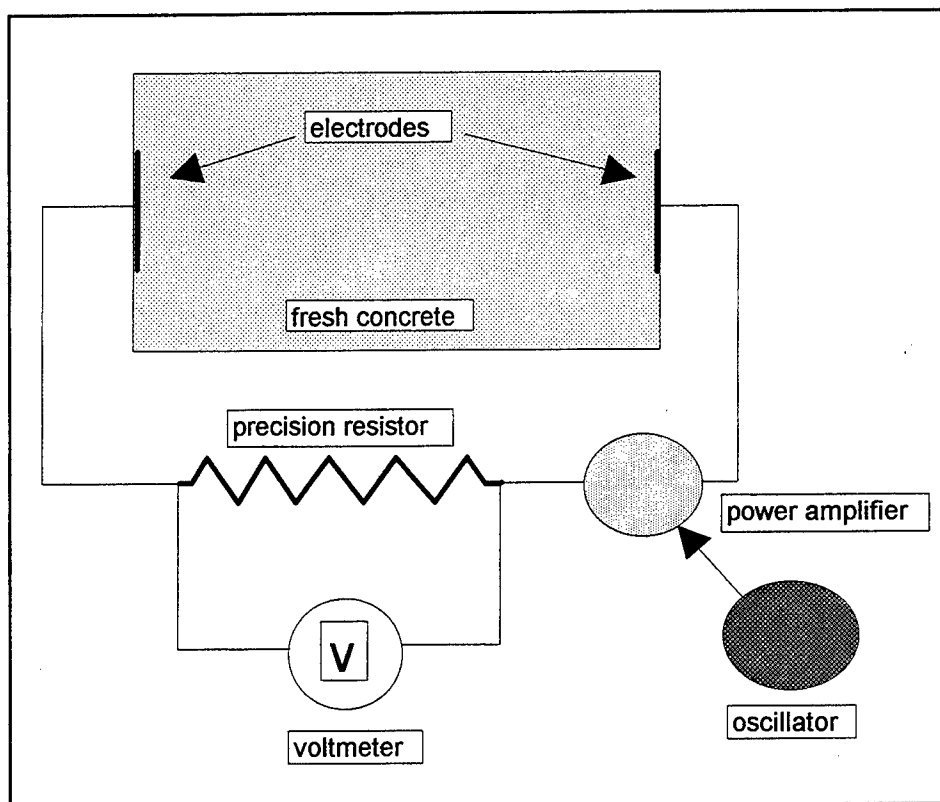

Figure 42. AC voltmeter-ammeter measurement configuration for fresh concrete

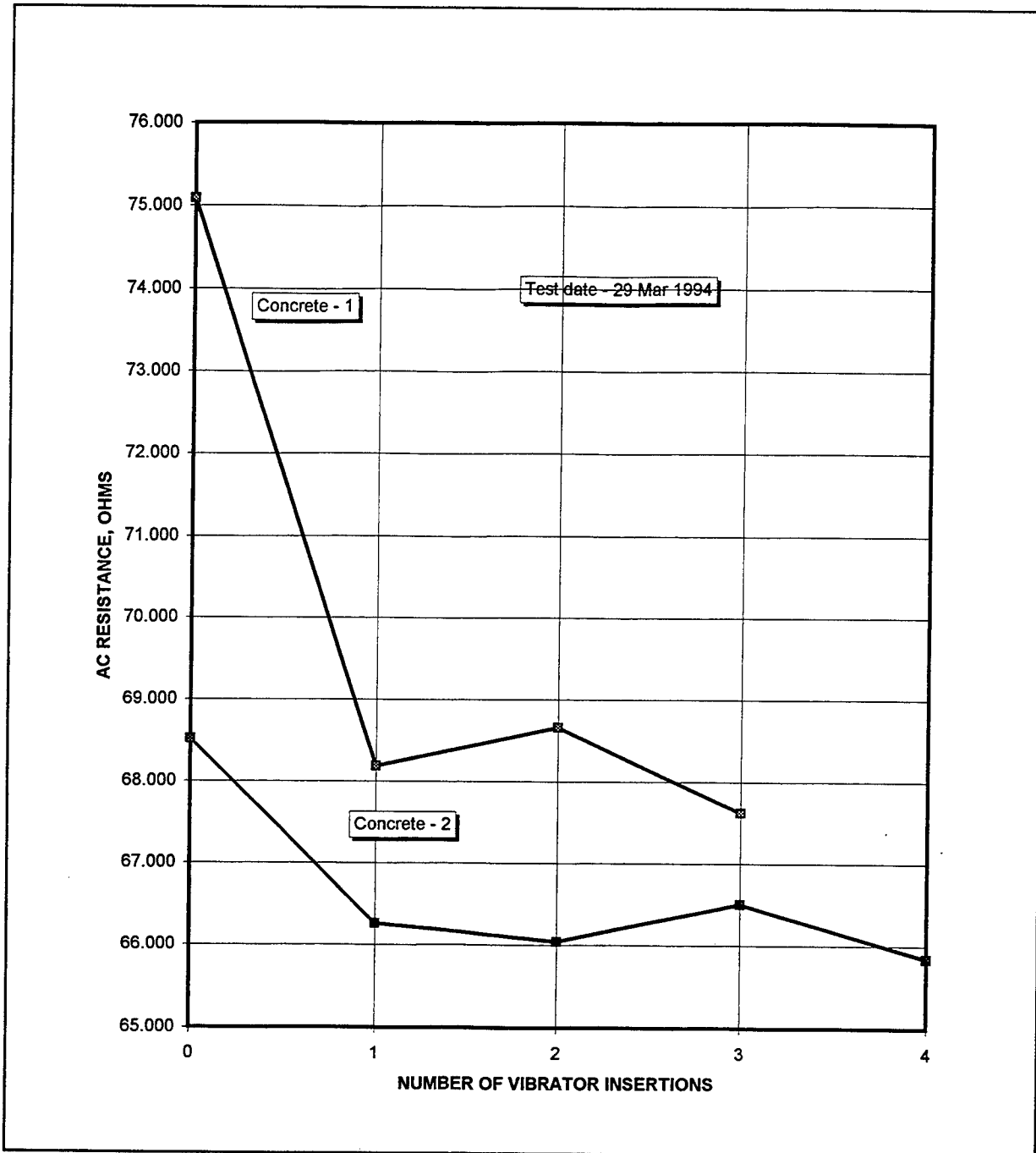

Figure 43. AC resistance of fresh concrete after short intervals of poker vibration

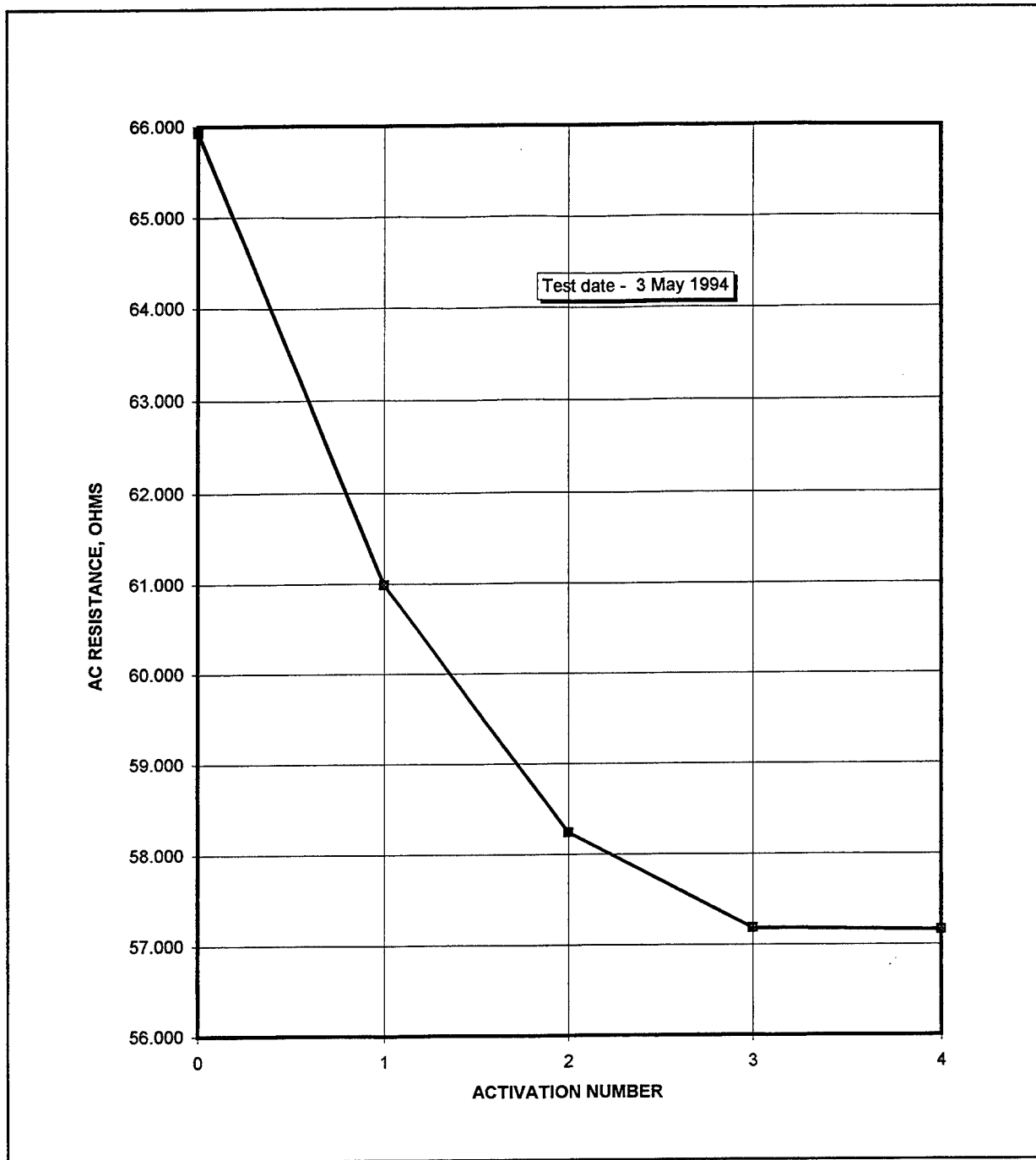

Figure 44. AC resistance of fresh concrete after short intervals of shaker table vibration

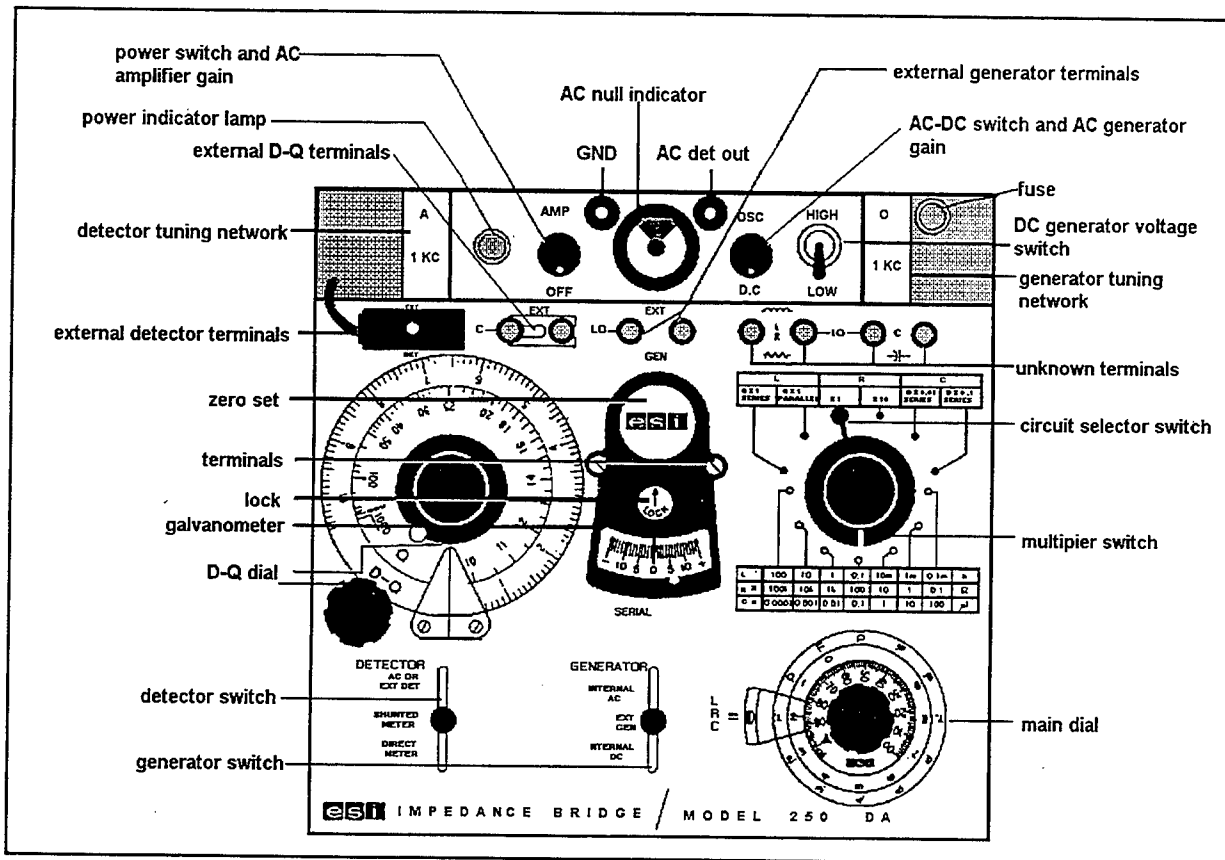

Figure 45. Diagram of front panel of ESI 250DA bridge (modified from Electro Scientific Industries, Inc. 1963)

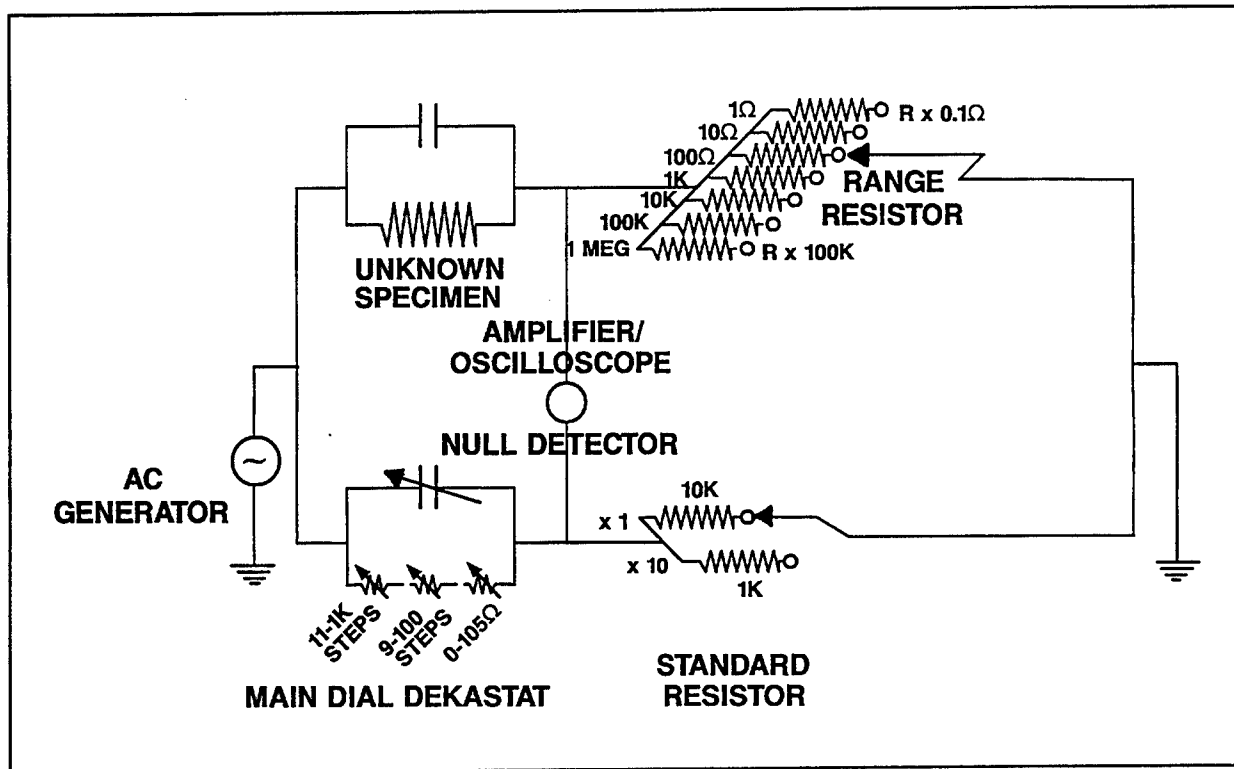

Figure 46. Schematic of ESI 250DA universal impedance bridge

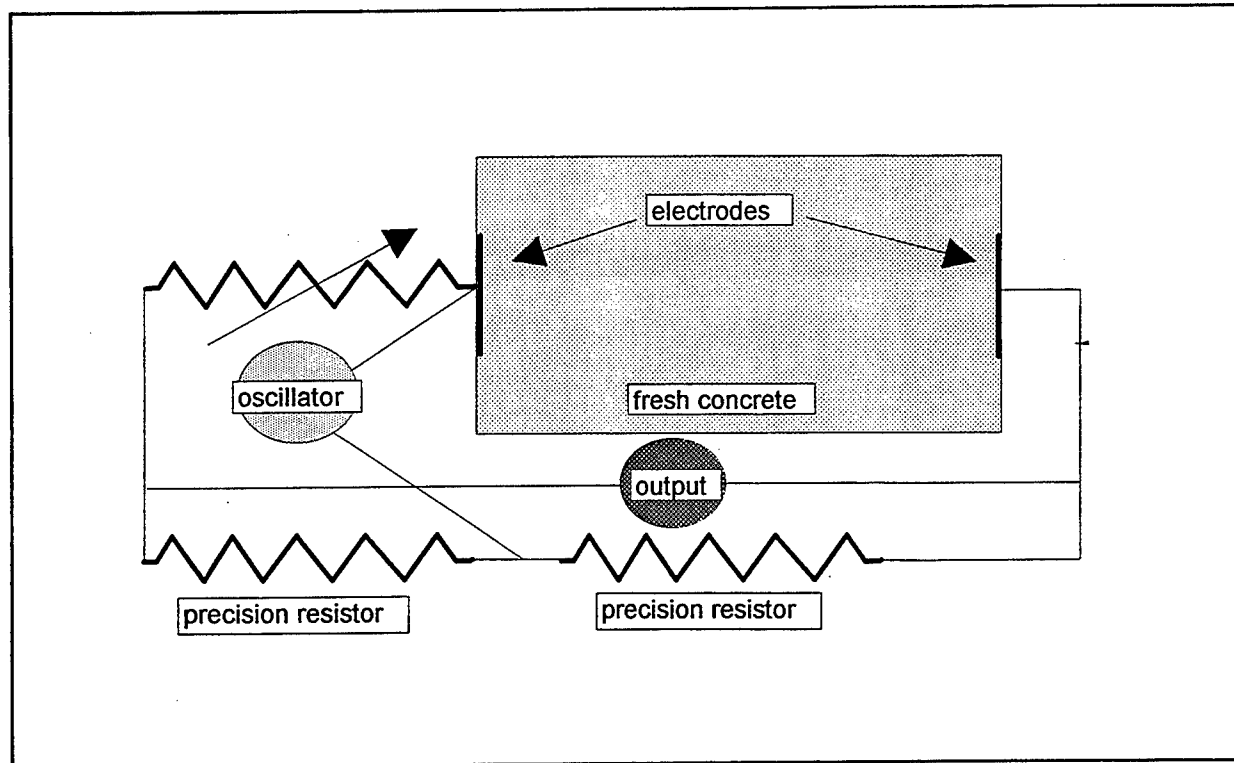

Figure 47. Wheatstone bridge measurement setup for consolidation measurement

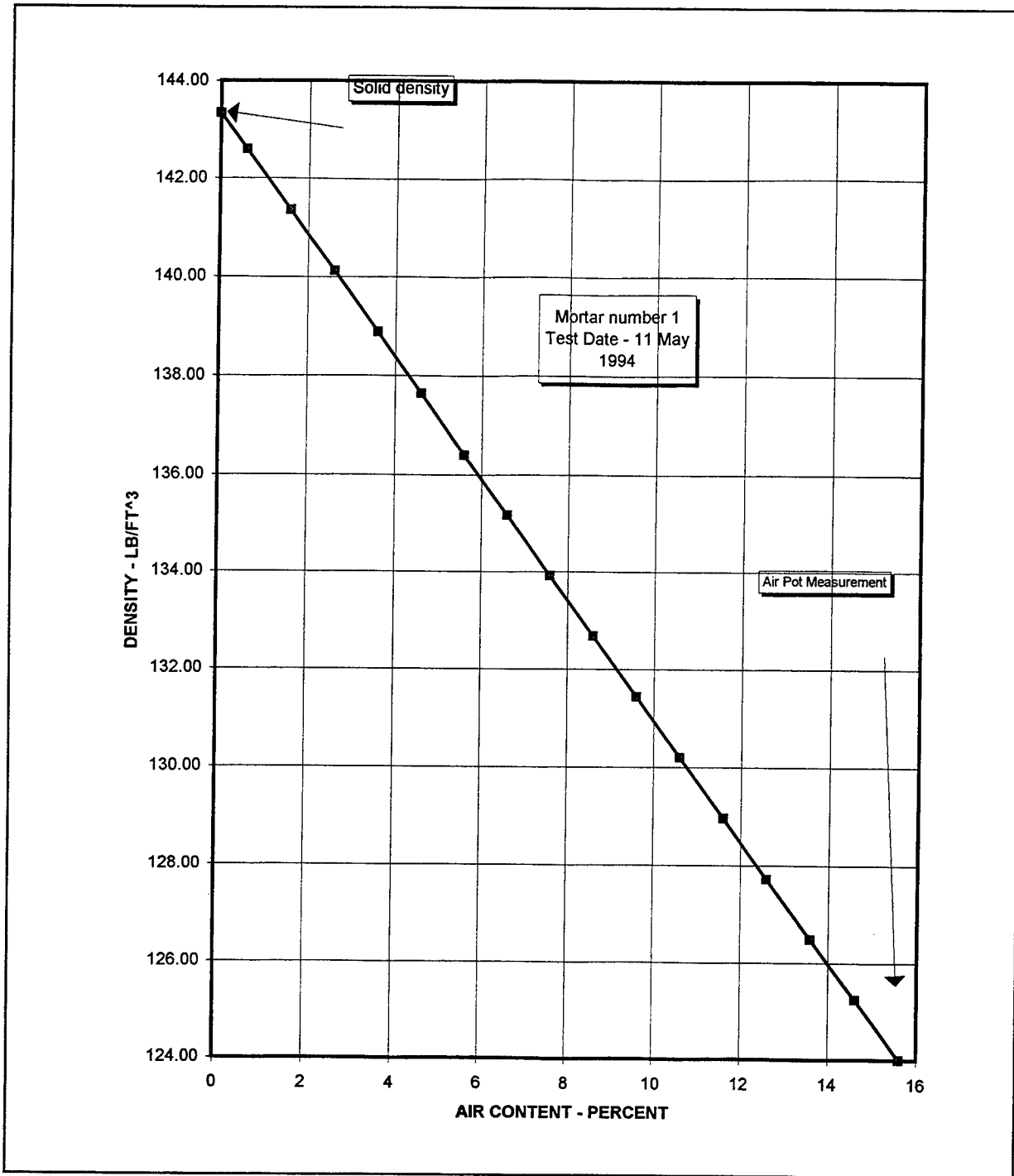

Figure 48. Relationship of percent air and density for mortar number one (1 lb/ft<sup>3</sup> = 16.01846 kg/m<sup>3</sup>)

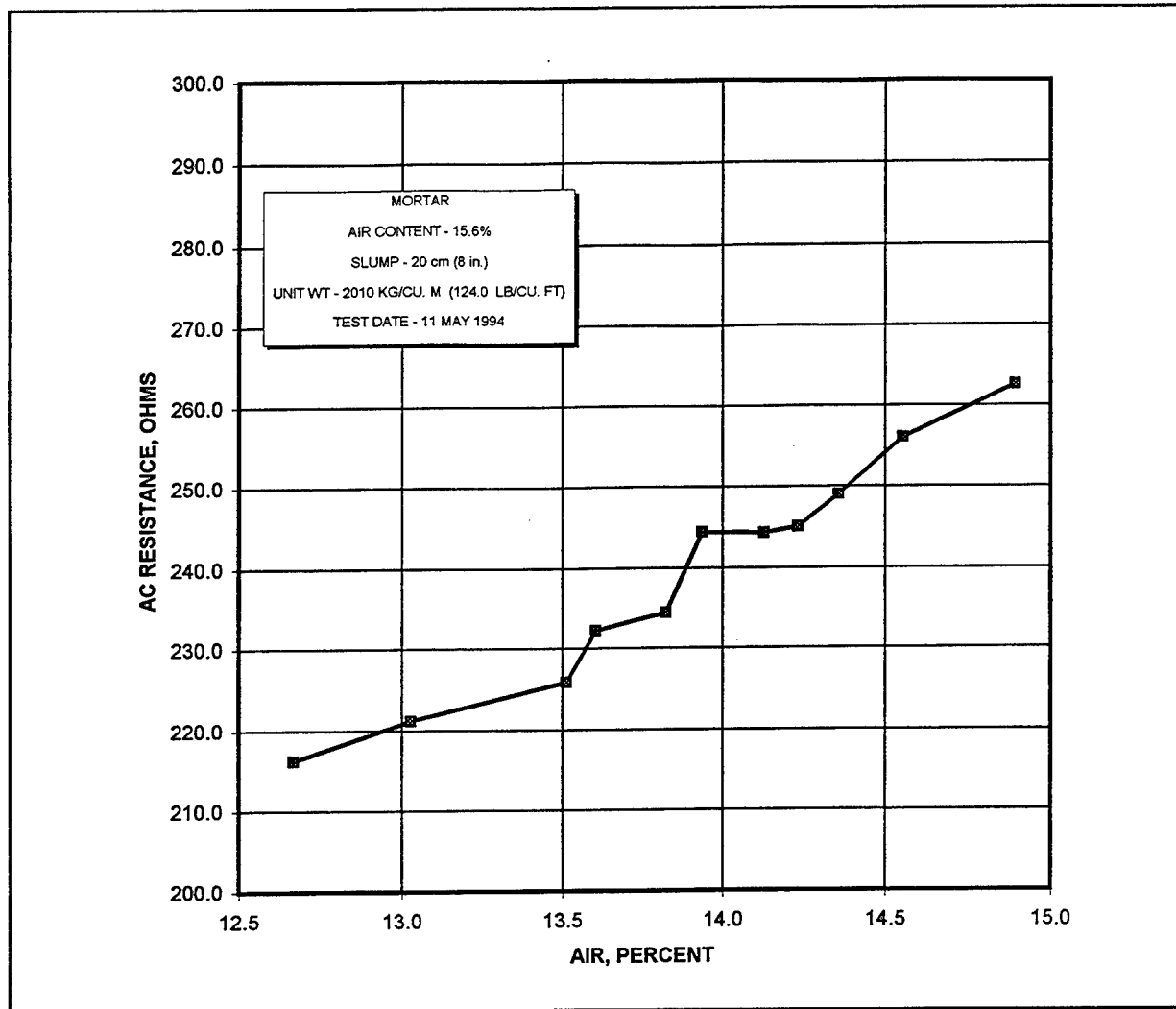

Figure 49. AC resistance of mortar versus air content for mortar no. 1

### AC RESISTANCE VERSUS AIR CONTENT ON MORTAR #2

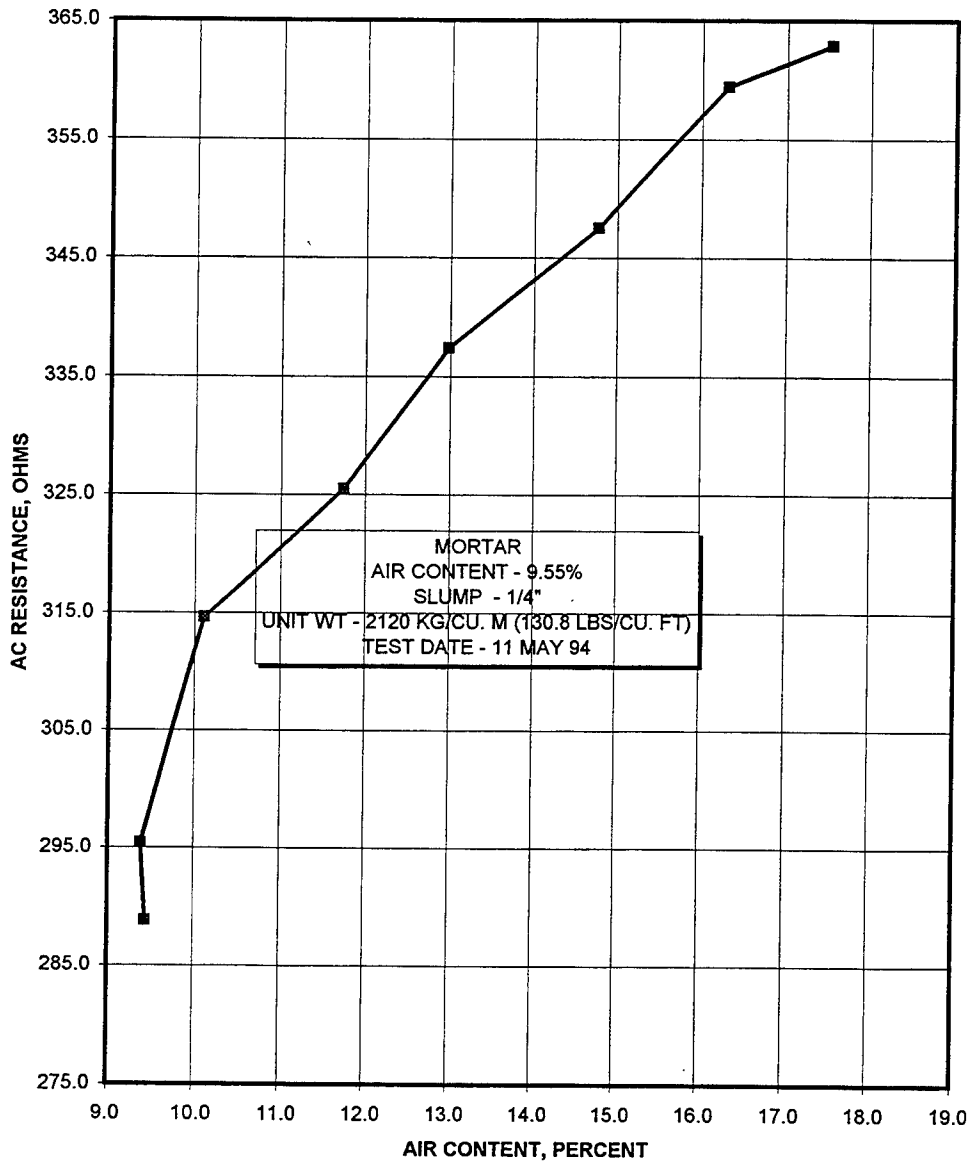

Figure 50. AC resistance of mortar versus air content for mortar no. 2

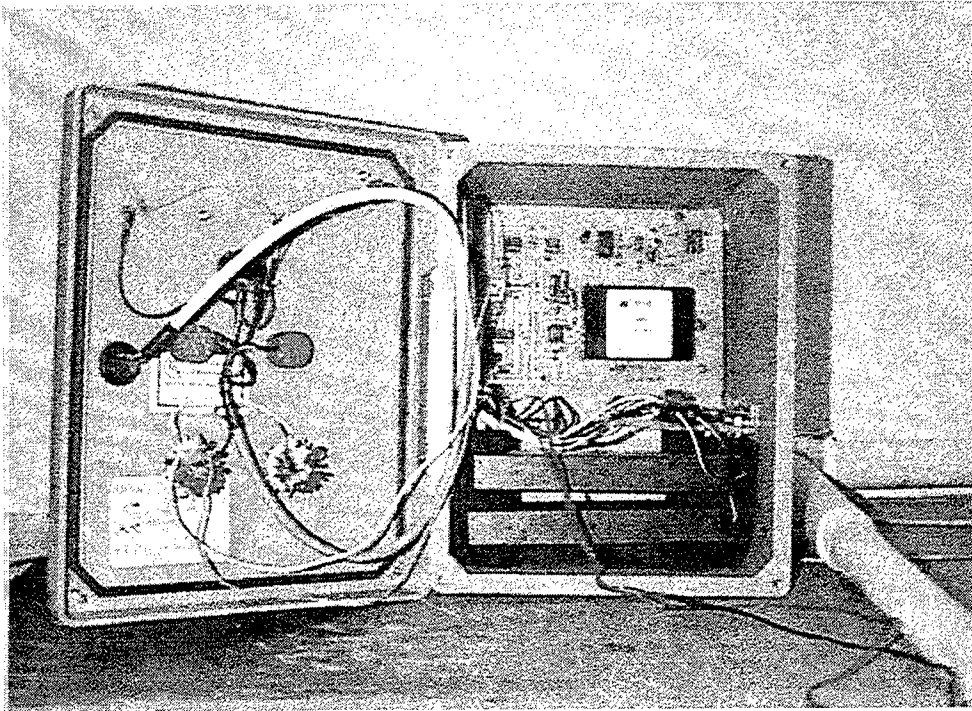

Figure 51. Consolidation meter

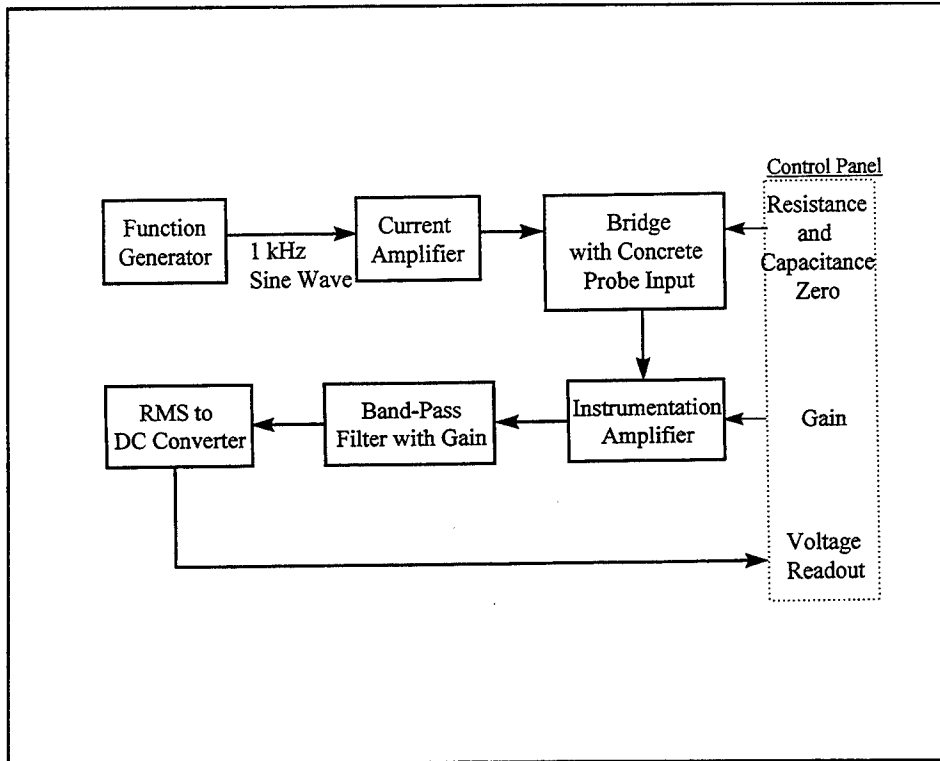

Figure 52. Block diagram of circuit functions of portable consolidation meter

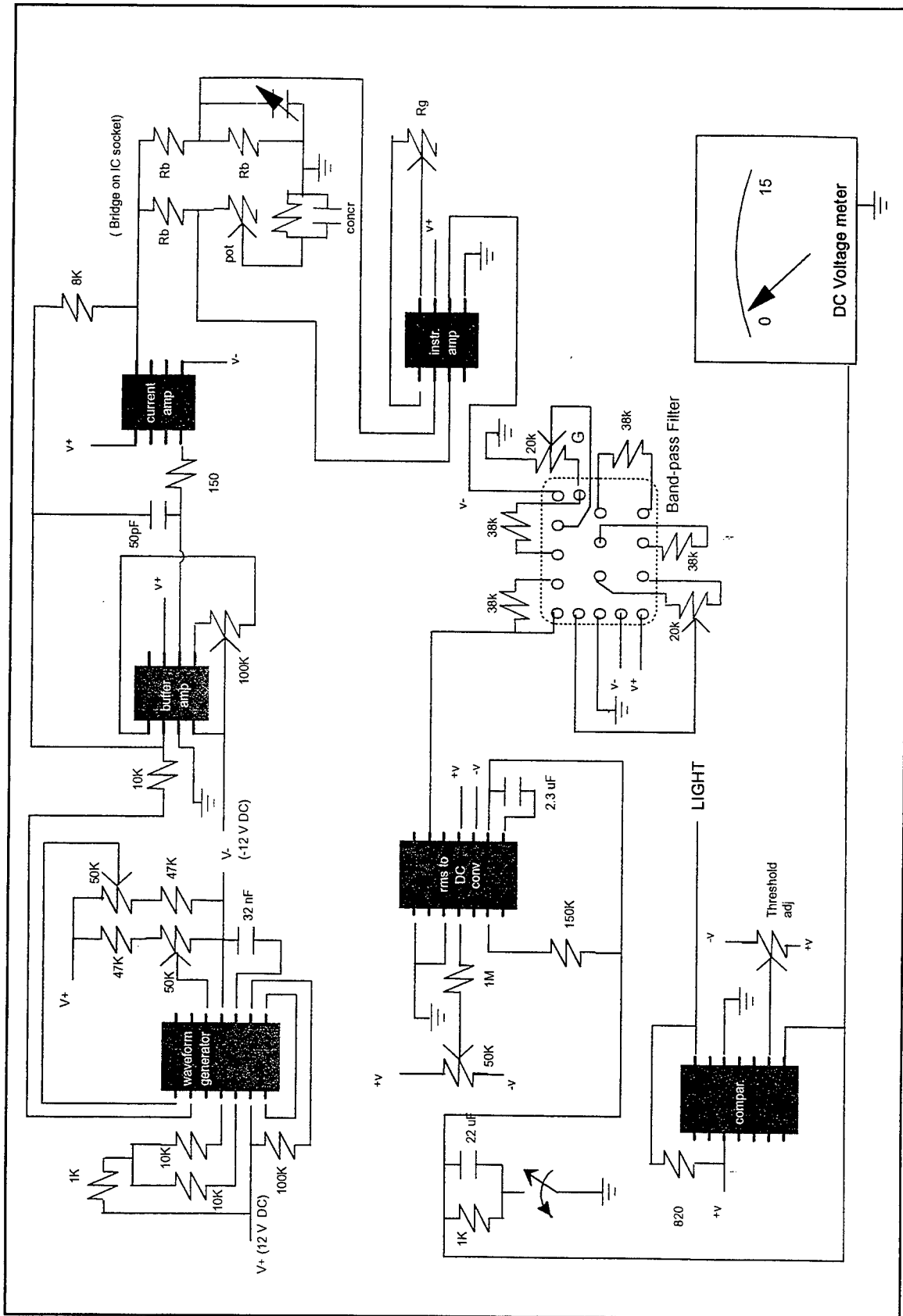

Figure 53. Schematic of final prototype consolidation meter

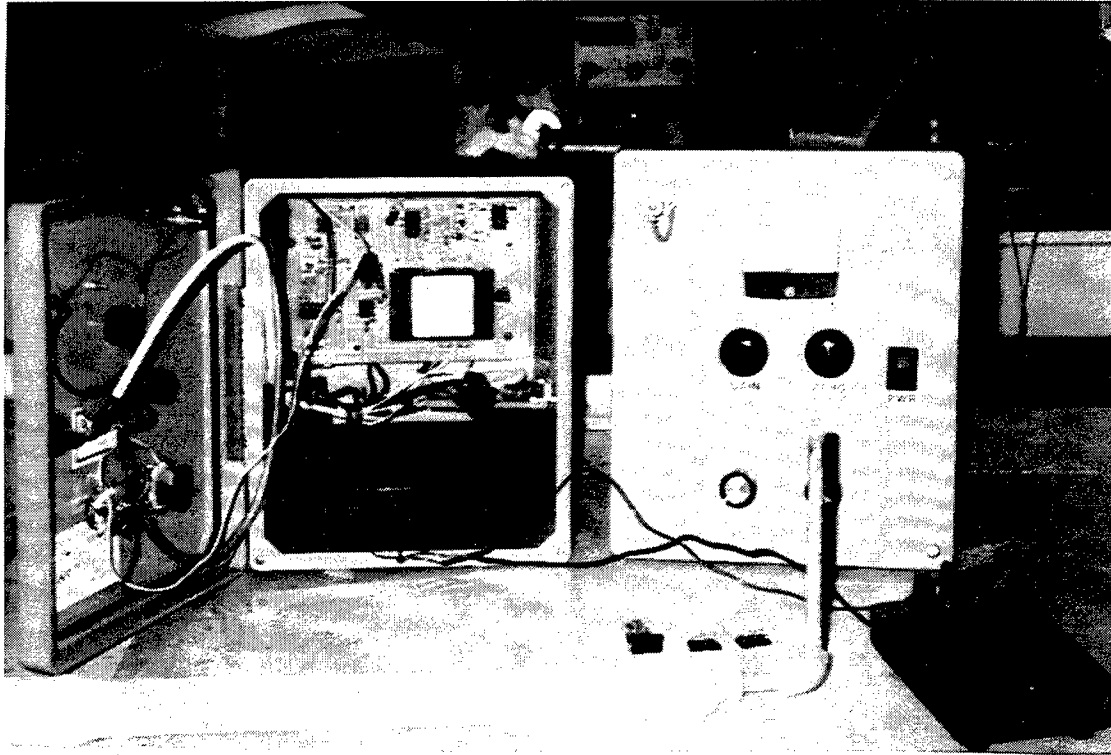

Figure 54. Meter probes

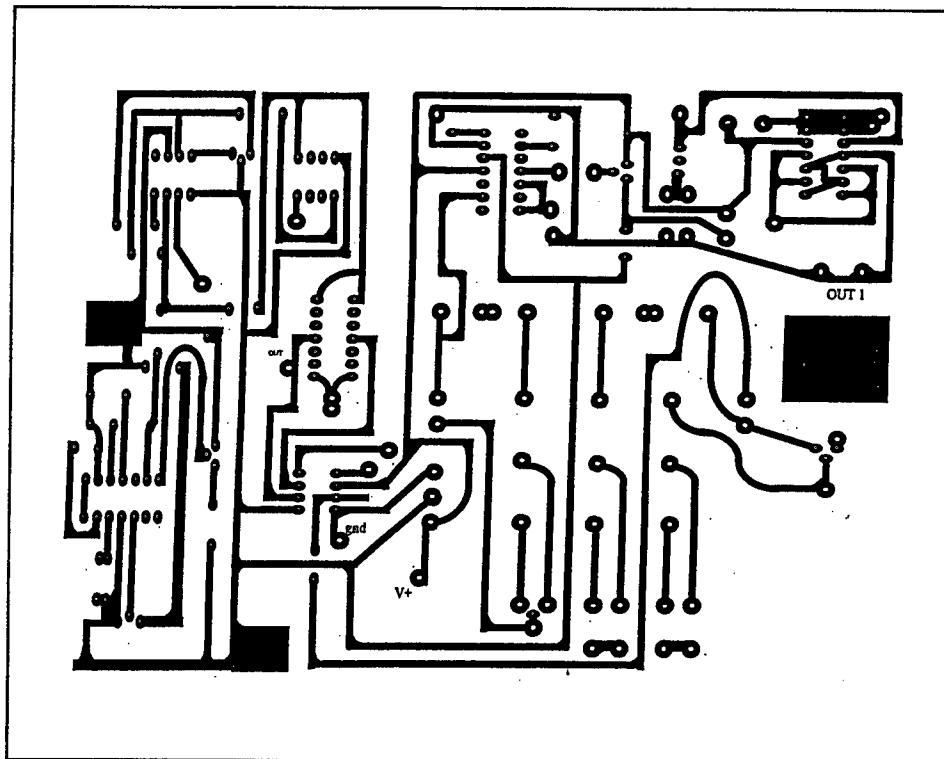

Figure 55. Diagram of etched circuit board of final prototype consolidation meter

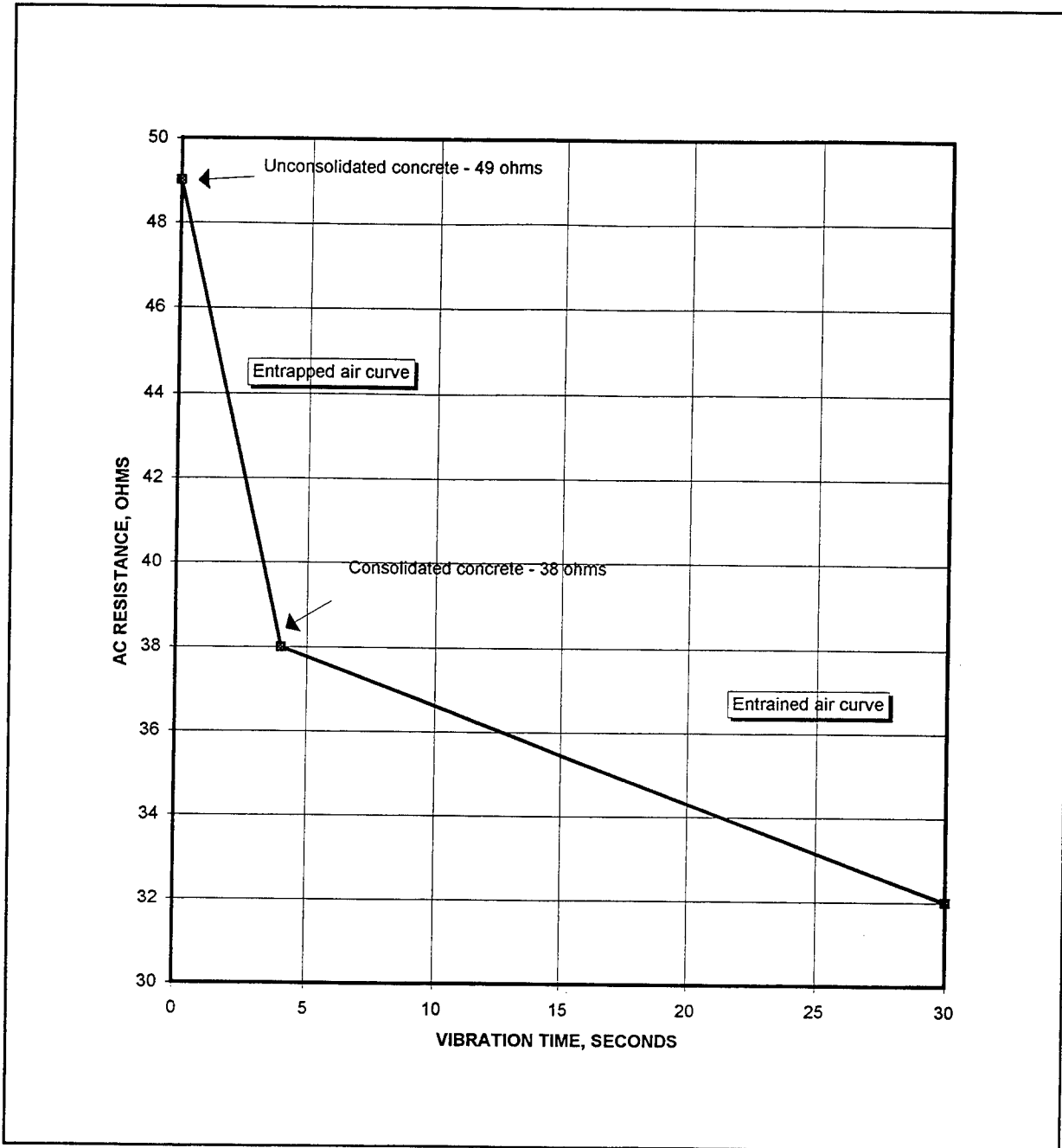

Figure 56. Idealized AC resistance of fresh concrete using dynamic consolidation meter during time of vibration

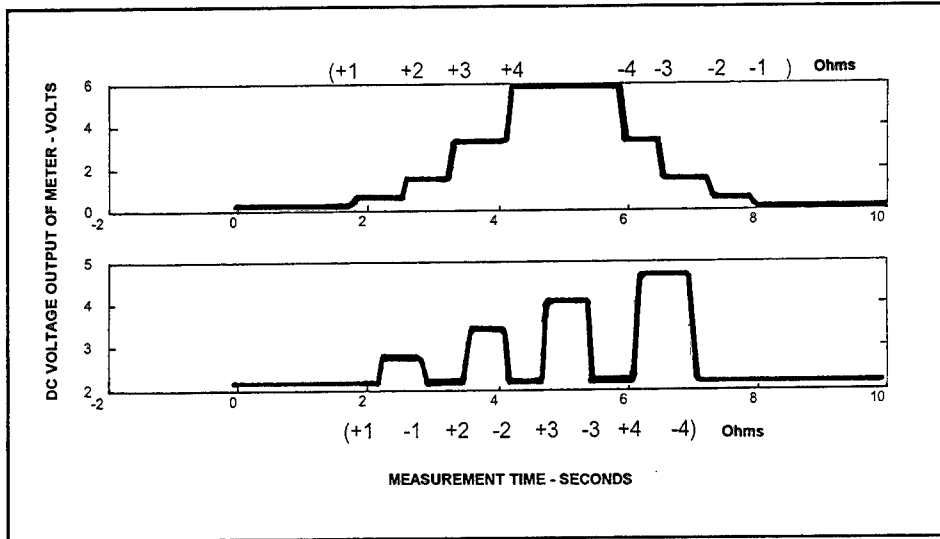

Figure 57. Calibration of portable field device correlating DC voltage output with resistance change introduced into probe arm from a decade resistor box

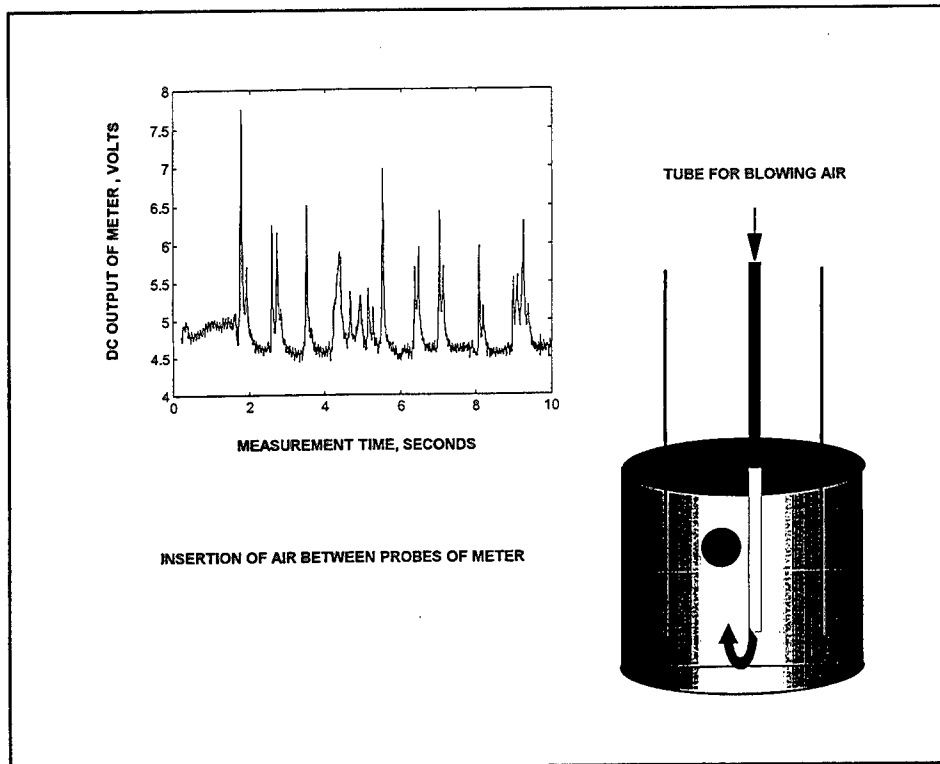

Figure 58. Demonstration of dynamic measurement response of consolidation meter when air is blown into thin viscous cement mixture from small-diameter tube

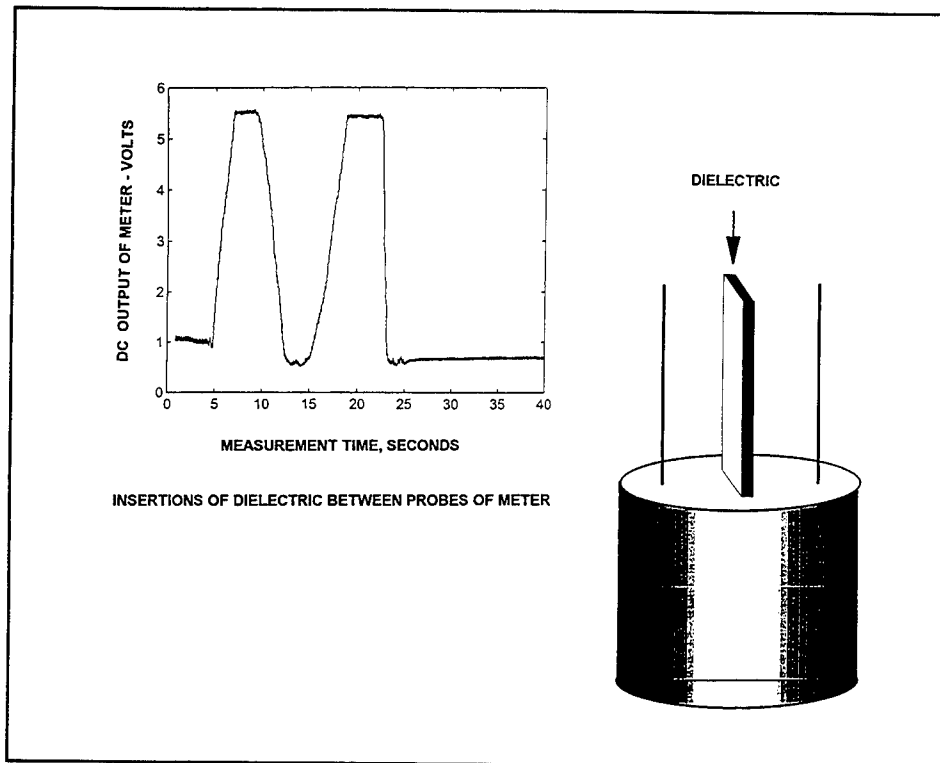

Figure 59. Demonstration of dynamic measurement response when dielectric is inserted into cement mixture to block electric field lines between electrodes and to increase AC resistance

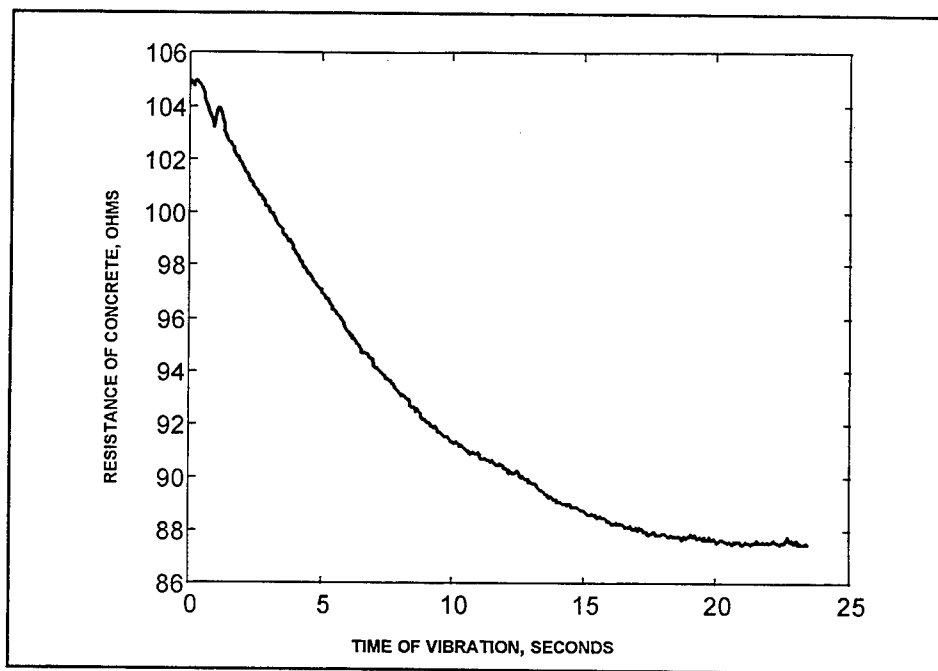

Figure 60. Dynamic consolidation meter measurement of percentage change in amount of total air released during consolidation process

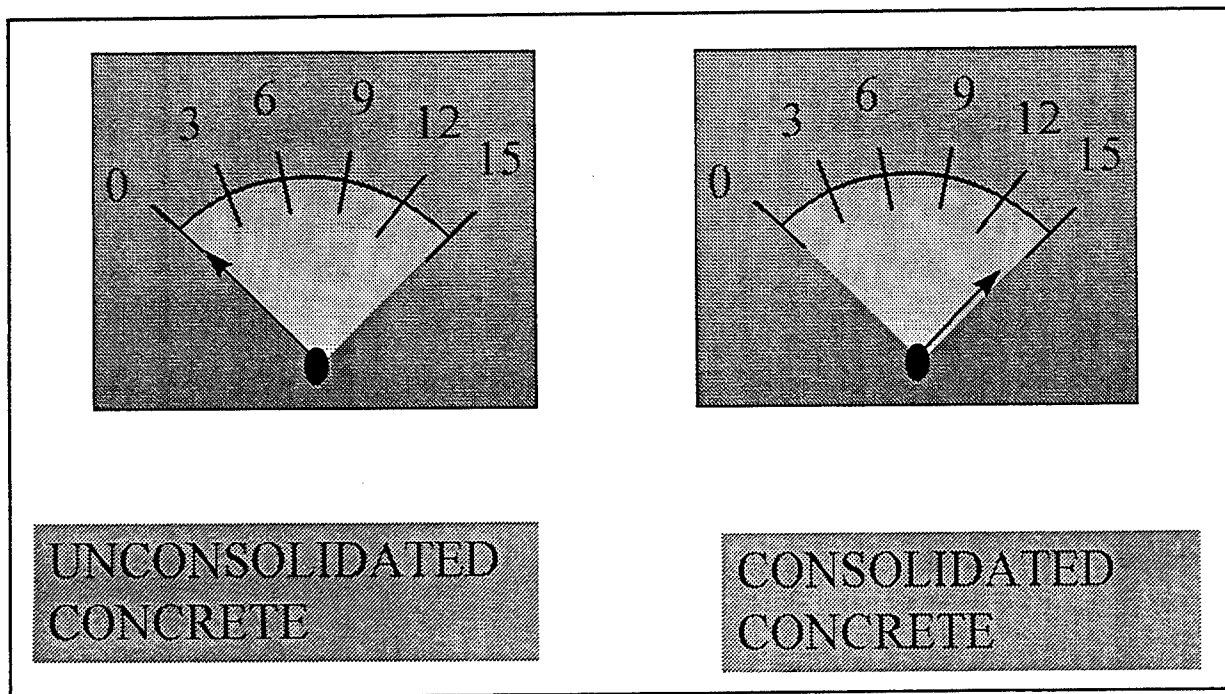

Figure 61. Calibration of consolidation meter

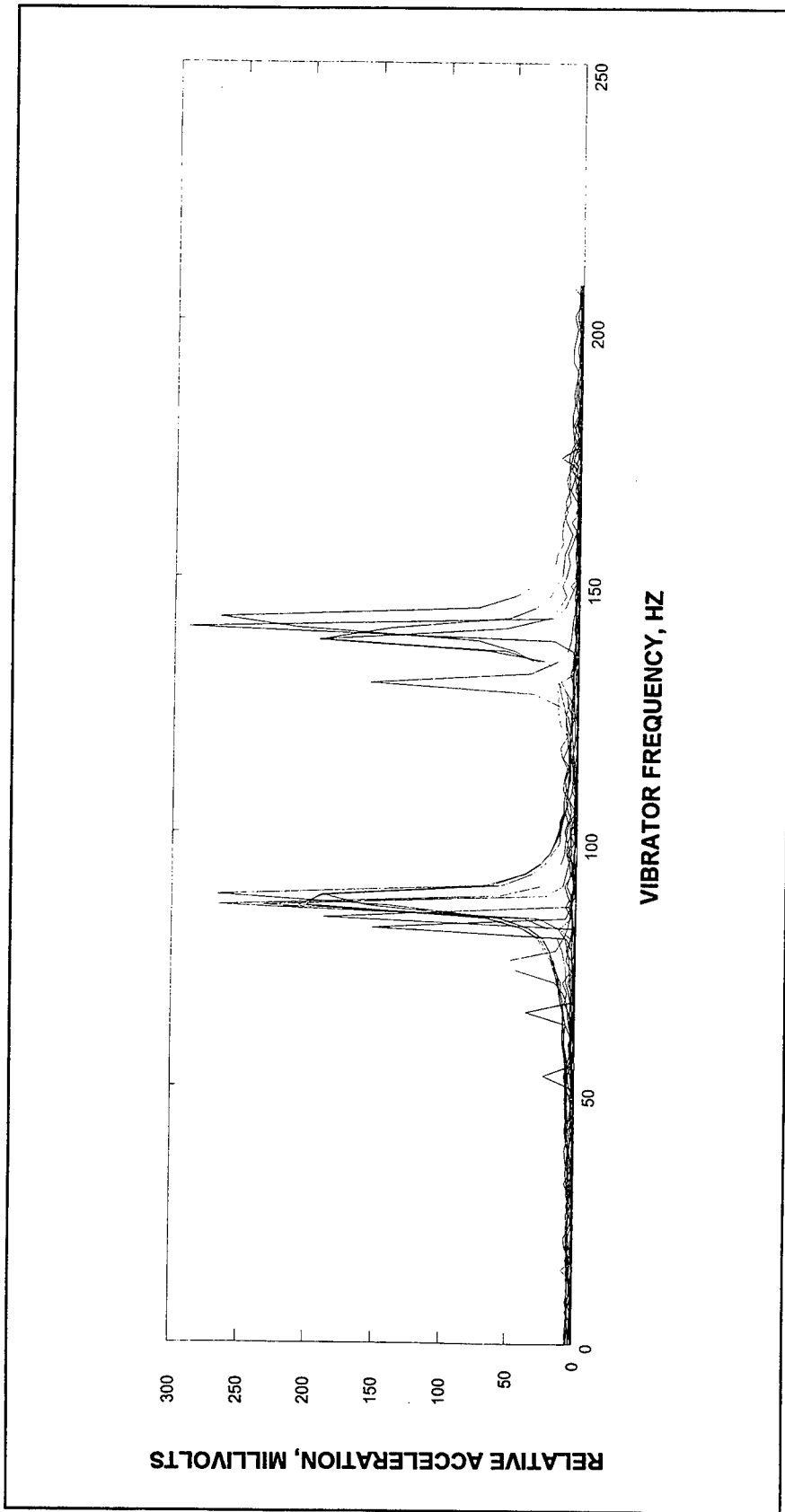

Figure 62. Response with increasing rotor speed from hydration shaker

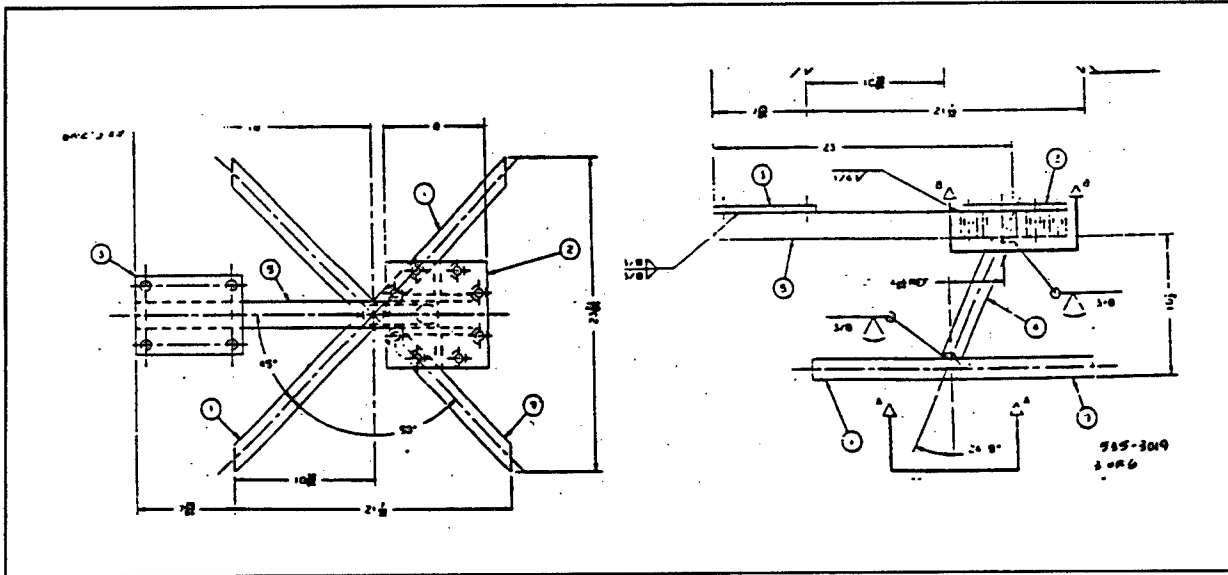

Figure 63. Conventional detailings

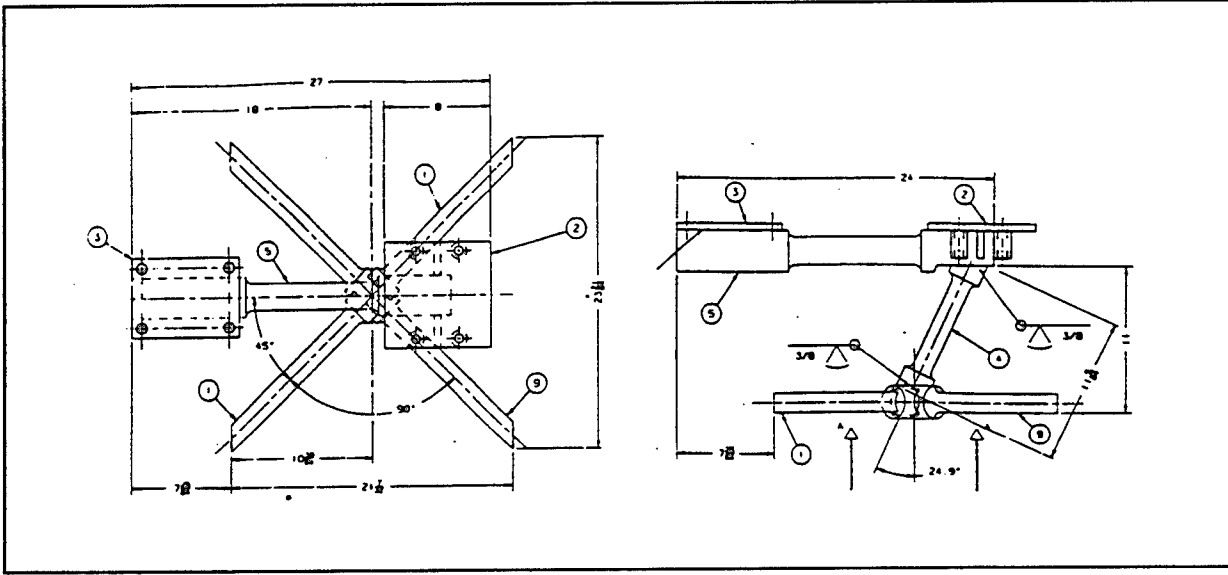

Figure 64. Detailings to smooth the connection areas

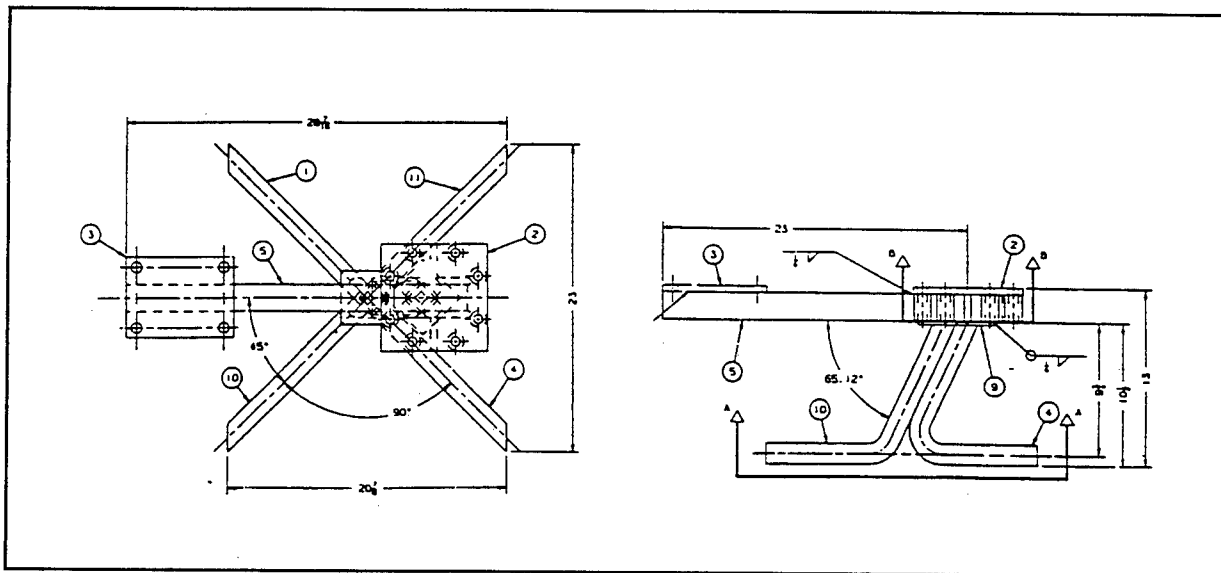

Figure 65. Detailings to eliminate welding in critical areas

# Appendix A

## Theory of Impedance Measurements in Concrete

---

### Resistivity Measurements and Concrete

The electrical resistivity property of concrete increases during the hydration process once setting has occurred. Hydration is a slow process that goes on for days but progresses at a higher rate in the first few hours. However, the hydration process should not influence the consolidation measurements. No perceptible change in the resistivity due to hydration would be expected in the short interval of time required for performing consolidation.

Fresh concrete has a resistivity of about 1 to 10 ohm-metres. Moist hardened structural concrete typically has a resistivity of about 25 to 45 ohm-metres. The electrical resistivity of cured cement paste lies in the region of 10 to 13 ohm-metres while most aggregates will lie above 300 ohm-metres (Whittington, McCarter, and Forde 1981<sup>1</sup>). Air-dried portland-cement paste and concrete lie in the region of  $6.54$  to  $11.4 \times 10^3$  ohm-metres (Waters 1952, Maguire and Olen 1940).

#### Path of least resistance

Because the resistivity of aggregate is several orders of magnitude greater than paste, it is evident that most of the current will take the path of least resistance and travel through the paste (Whittington, McCarter, and Forde 1981). Calleja (1952a) attributed the electrical resistance of cement paste to two factors: the ionic conductivity of the cement-water solution (depends on the ion concentration, type of ions, and temperature) and electronic conduction (due to increasing mechanical resistance and cohesiveness of various compounds in the paste as hydration progresses).

---

<sup>1</sup> References cited in this appendix are listed in the References at the end of the main text.

## **Fresh concrete acts as electrolyte**

According to Hughes, Soleit, and Brierley (1985), the resistivity of young concrete depends mainly upon the w/c and the amount of cement in the concrete. Also, the resistivity of young, moist-cured concrete is a function of the degree of hydration of cement paste within the concrete mixture. Nikkannen (1962) concluded that concretes are conductors, similar in nature to electrolytes, and listed data that showed the temperature coefficient for the electrical conductivity of fresh paste is of the same order of magnitude as that of common electrolytes. The temperature coefficient is negative; that is, an increase in temperature causes a decrease in resistivity and vice versa.

## **Alternating-current (AC) measurement**

The passage of a direct current (DC) through an electrolyte causes polarization, the establishment of a potential at the electrodes that opposes the applied potential, complicating the measurement of specimen resistance. The problem of polarization is overcome by utilizing AC power. Calleja (1952a) states that the AC frequency used in the determination of the electrical resistance of cement paste should not be below 1 kHz. This report focuses on AC-resistance and -impedance measurements on fresh concrete. The hypothesis of this investigation was that the property of resistivity of fresh concrete should decrease as the entrapped air exits the material during the consolidation process. Air is an insulator trapped loosely inside a conductor.

## **Other Possible Applications**

### **Strength detector**

Resistivity measurements have a very important place in the study of concrete properties for both fresh and hardened concrete. There are various potential uses of resistivity data for concrete. One use includes the quality control of structural concrete prior to hardening to determine its future strength (McCarter, Forde, and Whittington 1981). As the electrical resistivity of young, moist-cured concrete is a function of the water to cement ratio (w/c), cement content, and the degree of hydration of cement paste within the mixture, its resistivity may provide an indirect measure of its future strength, and hence it is a potential nondestructive testing (NDT) technique in the quality control of structural concrete (Hughes, Soleit, and Brierley 1985).

### **Consolidation detector**

The resistivity is related to the air content and the pore-size distribution and therefore should be related to the degree of consolidation (hence the basis of this investigation) (Alexander 1992).

## Ohm's Law

Resistance is a measure of the difficulty an electrical current encounters when passing through a material. There are no perfect conductors or perfect insulators. A perfect conductor would have zero resistance, and a perfect insulator would have an infinitely large resistance. Both conditions are unobtainable ideals. Resistance is measured in ohms and indicates the magnitude of voltage (electrical pressure) required to force a given current of electronic flow through a material. Equations A1 and A2 are two variations of Ohm's law that describe this relationship.

$$V = IR \quad (A1)$$

$$R = \frac{V}{I} \quad (A2)$$

where

V = voltage (volts)

I = current (amperes)

R = resistance of volume between electrodes (ohms)

## Resistivity

### Equation describing resistivity

The resistance of fresh concrete or any other material depends not only on the electrical properties of the material but also on the size and shape of the specimen. The measure of resistance that relates purely to the properties of the material (independent of the size and shape) is called the resistivity or specific resistance and is assigned the symbol  $\rho$ . Volume resistivity (as opposed to surface resistivity) is defined as the resistance through the volume of the material between opposite faces of a cube having unit length. If the dimensions of the cube are in centimetres, then the unit of resistivity is ohm-centimetres; if metres, then ohm-metres, etc. The numerical value of the resistivity of a cube of unit dimensions is equal to the numerical value of the resistance between the two electrodes ( $\rho = R$  when  $A = 1$  and  $L = 1$ ). (See Equation A3 below.) The resistivity can be calculated for shapes such as a prism or cylinder as well as a cube. However, the numerical value of the resistance will not equal the numerical value of the resistivity when the dimensions differ from unitary unit values. The equation is:

$$\rho = R \left( \frac{A}{L} \right) \quad (A3)$$

where

- $\rho$  = resistivity of material (ohm-metres)
- A = area of specimen electrodes (metres<sup>2</sup>)
- L = length of specimen between electrodes (metres)

### Resistivity of various materials

The insulating properties of different materials are often compared with each other in terms of their resistivities. See Table A1 for a comparison. The resistivity of conductors is sometimes expressed in terms of the units of conductivity. The reciprocal of resistivity is conductivity and is expressed in mhos/metres (note that mho is ohm spelled backwards).

<b>Table A1 Resistivity of Concrete and Materials Ranging from Insulators to Conductors</b>	
<b>Material</b>	<b>Resistivity (ohm-metres)</b>
Polyethylene	$1 \times 10^{15}$
Glass	$2 \times 10^{11}$
Epoxies	$1 \times 10^{11}$
Oven-dried concrete	$1 \times 10^6$
Pure water	$1 \times 10^4$
Granite rock	$5 \times 10^3 - 1 \times 10^6$
Limestone	$3 \times 10^2 - 1.5 \times 10^3$
Air-dried concrete	$6.5 - 11.4 \times 10^3$
Fresh concrete	1-10
Tap water	100 - 150
Moist-cured concrete (ionic)	50
Cement paste	10-13
Moist-cured concrete (electronic)	10
Copper	$1.5 \times 10^{-8}$

### Conductors and insulators

Typical mixing water has a resistivity of about 100 to 150 ohm-metres. Pure water has an electrical resistivity of about  $1 \times 10^4$  ohm-metres. Glass has a resistivity greater than  $1 \times 10^9$  ohm-metres. Resistivity can be compared with metals for which a typical value is  $1 \times 10^{-7}$  to  $1 \times 10^{-8}$  ohm-metres. Copper is a very good conductor of electricity and has a resistivity of  $1.5 \times 10^{-8}$  ohm-metres. The range of resistivity is so large between insulators and conductors that both

classes can easily be classified with degrees of bad, poor, fair, good, excellent, etc. (*Encyclopedia Britannica* 1978).

## Ions

An ion is an electrically charged atom or molecule. A negatively charged ion is called an anion, and a positively charged ion is called a cation. In chemical notation, ions are accompanied by plus and minus signs which indicate the electric charge; in other words, one plus sign indicates that the atom or group of atoms is short of one electron and therefore has a positive charge. Two minus signs indicate two extra electrons, etc. Some of the ions present in concrete (Ravindrarajah, Sri, and Swamy 1982) are listed in Table A2.

Chemical Notations	Elements
H <sup>+</sup>	Hydrogen ion or proton
Ca <sup>++</sup>	Calcium
Na <sup>+</sup>	Sodium
Cl <sup>-</sup>	Chloride
SO <sub>4</sub> <sup>--</sup>	Sulfate
NO <sub>3</sub> <sup>-</sup>	Nitrates
K <sup>+</sup>	Potassium
OH <sup>-</sup>	Hydroxide

## Polarization

If a DC voltage is applied across two metal electrodes in an electrolyte (substance containing ions), the negative ions migrate to the positive electrode, and the positive ions migrate to the negative electrode. These ions build up at the electrodes (ions cannot travel through wires like electrons) and cause a polarization voltage to develop that opposes the power-supply voltage. The electron current will begin to approach zero, and it will appear that one is measuring the resistance of an insulator rather than a conductor. (This is similar to the action of a capacitor in that the capacitor will polarize and charge up to equal the voltage of the battery supplying the current and cause the current to decrease to zero.) Therefore, the polarity of the excitation voltage applied to the electrodes must be switched back and forth (AC power) rather than the polarity being kept constant (DC power) to create electron flow (current) through the lead wires and ionic

flow through the concrete to prevent the polarization phenomenon from annihilating (undoing) the measurement. Fresh concrete is an electrolyte that conducts electrons through the movement of charged atoms (ions).

## Wheatstone Bridge

### Importance of Wheatstone bridge

Wheatstone bridges are valuable instruments for measuring resistance (White and Manning 1954). Their accuracy does not depend on a regulated power supply or standard cell (at least for a balanced bridge as was the case with the universal impedance bridge that was used prior to development of the field system). The simple Wheatstone bridge remains useful largely because it is cheap, easy to construct, and accurate enough for most laboratory purposes (*Encyclopedia Britannica* 1978). Many special bridges (Sarbacher 1959) have been developed to do particular jobs and are adaptations of the Wheatstone bridge: Anderson, Campbell, Hay, Meuller, and Schering bridge, etc. The basic bridge performs well for measurements of resistance between the limits of 10 ohms and 10,000 Mohms. The Wheatstone bridge is a direct method of measuring resistance and can be powered by AC or DC. Understanding the Wheatstone bridge is basic to understanding the operation of the CM developed in this project. It is also necessary for understanding the impedance bridge used in this investigation. A Wheatstone-bridge circuit offers an ideal method for measuring the electrical resistance of fresh concrete.

### Configuration of Wheatstone bridge

A Wheatstone bridge is a combination of two voltage dividers (potentiometers) that are formed from four resistors. Figure A1 shows a schematic diagram of a potentiometer. Values for two of the resistances are known, and the third resistance is adjusted to a known value at null to equal the unknown resistance (fresh concrete in this project). A potentiometer is a three-terminal resistor with a center connection. (A common use of a potentiometer is as a volume control in a household radio. The center connection is adjustable in this example. As the volume control is turned up, the center tap goes from the maximum counterclockwise position of zero ohms to the full range of resistance on the maximum clockwise position.) Consider the operation of a potentiometer. If some voltage ( $V$ ) is applied across the ends of the potentiometer, the two voltages across each resistor will have the same ratio as the resistances. See Equations A4, A5, and A6.

$$V_1 = IR_1 \quad (A4)$$

$$V_2 = IR_2 \quad (A5)$$

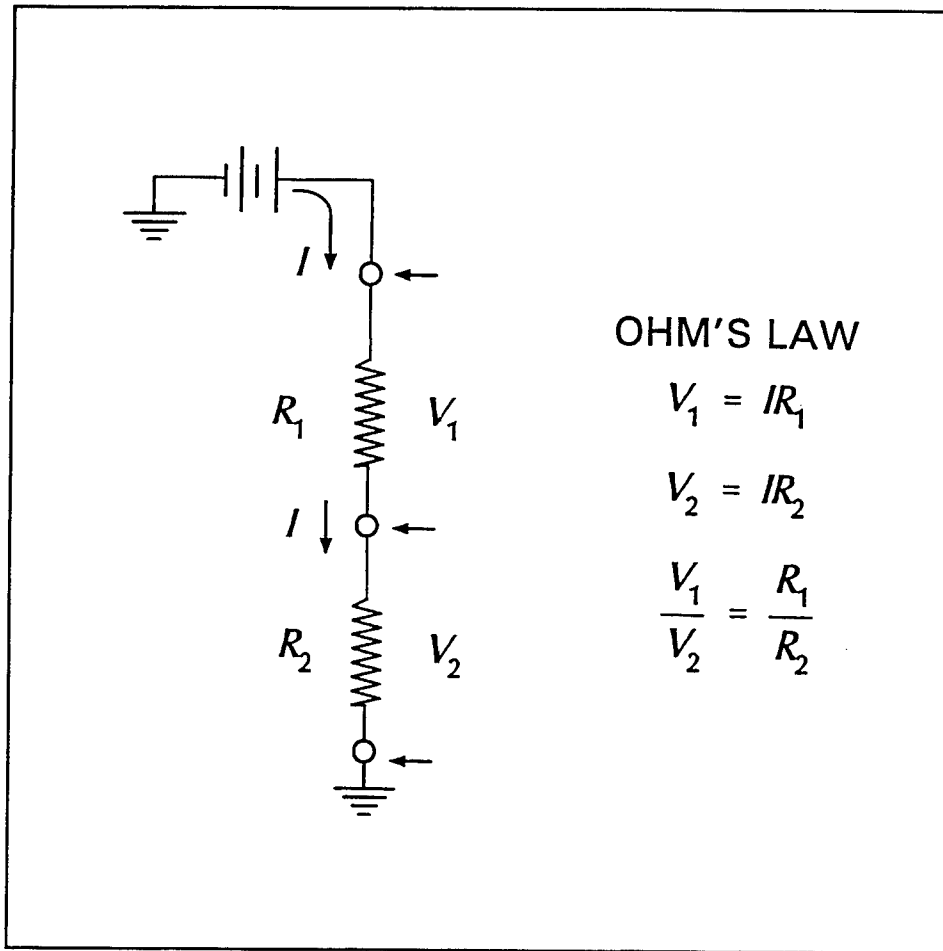

Figure A1. Ratios of voltages are equal to ratio of resistances for potentiometric circuit

$$\frac{V_1}{V_2} = \frac{R_1}{R_2} \tag{A6}$$

### Operation of a Wheatstone bridge

As mentioned, with the addition of a second potentiometer to the first, a Wheatstone bridge is constructed. Both potentiometers experience the same applied voltage. Figure A2 shows the construction of a Wheatstone bridge. If a high-resistance null detector is now inserted between the points A and B, then the second potentiometer can be adjusted such that the voltage at A with respect to ground is equal to the voltage at B with respect to ground. This is called a balanced bridge circuit. In other words, A and B are at the same potential, and the voltage across the null detector is zero. When  $R_3$  is adjusted such that the voltage is nulled, then

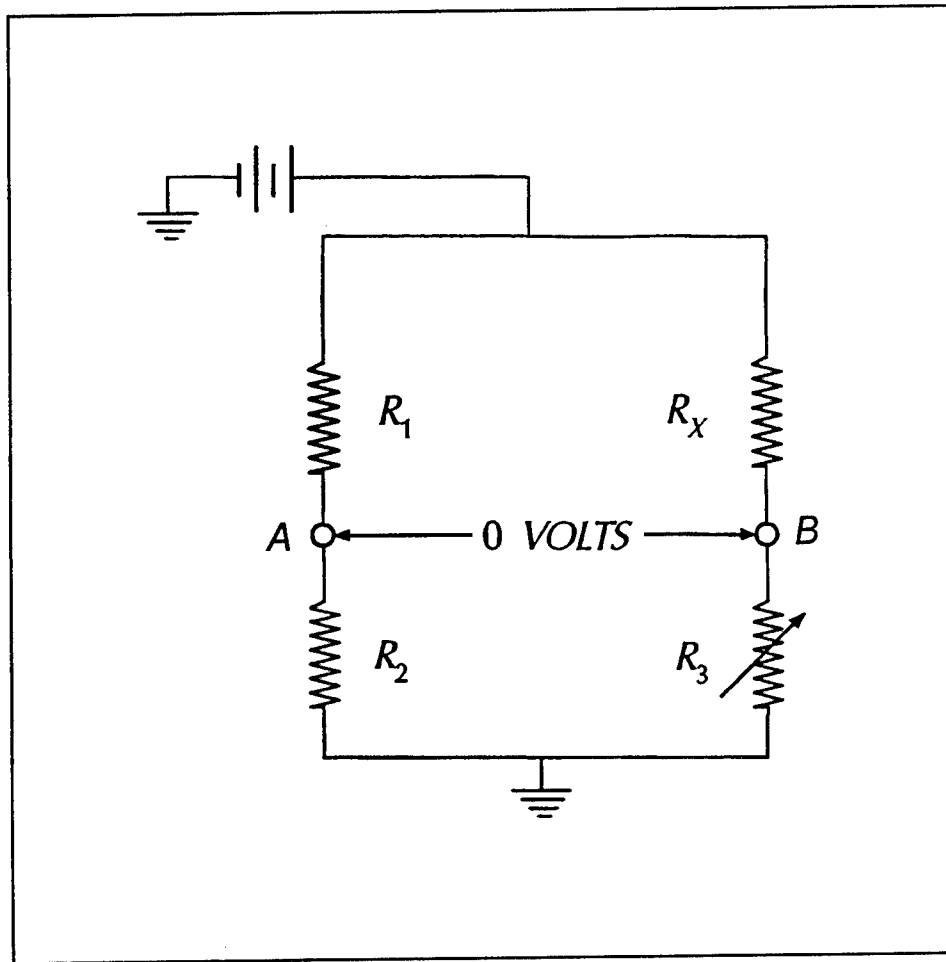

Figure A2. Wheatstone bridge at balance powered by direct current

$$\frac{R_1}{R_2} = \frac{R_x}{R_3} \quad (A7)$$

$$R_x = R_3 \frac{R_1}{R_2} \quad (A8)$$

where  $R_x$  refers to the resistance of the unknown.

The unknown value of resistor  $R_x$  can be accurately determined if the other three are standard resistors whose values are known accurately. By definition, a Wheatstone bridge is purely resistive with DC or AC applied as the excitation voltage. When the bridge arm with the unknown resistance contains capacitance or inductance, then at least one of the other three bridge arms must also contain reactive components in order to obtain a current balance. This type of bridge is referred to as an impedance bridge.

## Impedance Bridge

### AC bridge

In this project, because of the phenomenon of polarization and because the fresh concrete is not purely resistive, AC must be used to power the bridge. Measurements of impedance with AC are similar to measurements of resistance with DC but are more intricate than DC. Not only must the magnitude of the bridge output be balanced (nulled), but the phase must be balanced also. The simpler Wheatstone bridge requires only a balance of the magnitude because the phase is always zero for purely resistive bridges. (The voltage is always in phase with current across a resistor.) A null detector must be an AC device (e.g., oscilloscope or headphones) rather than a DC device (e.g., galvanometer). Fresh concrete has been found to behave electrically as a resistor and capacitor in parallel, as shown in Figure A3. A bridge balance then requires the adjustment of two components, rather than one, in the arm adjacent to the concrete probe arm to

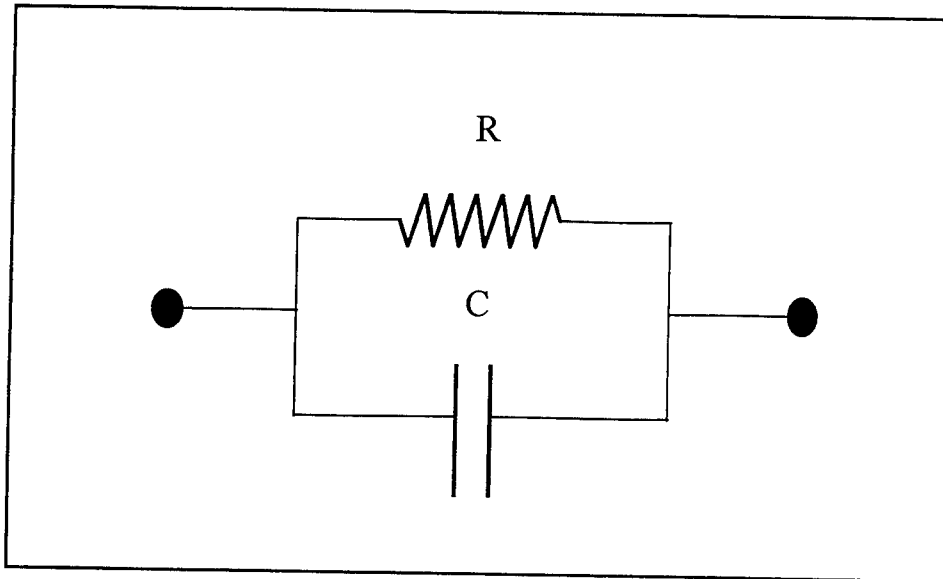

Figure A3. Fresh concrete is modeled by an RC circuit

create a null. The bridge diagram and equations for an impedance balance follow. See Figure A4 and Equations A9 and A10.

$$\frac{Z_A}{R_1} = \frac{Z_X}{R_2} \quad (\text{A9})$$

$$Z_X = Z_A \left( \frac{R_2}{R_1} \right) \quad (\text{A10})$$

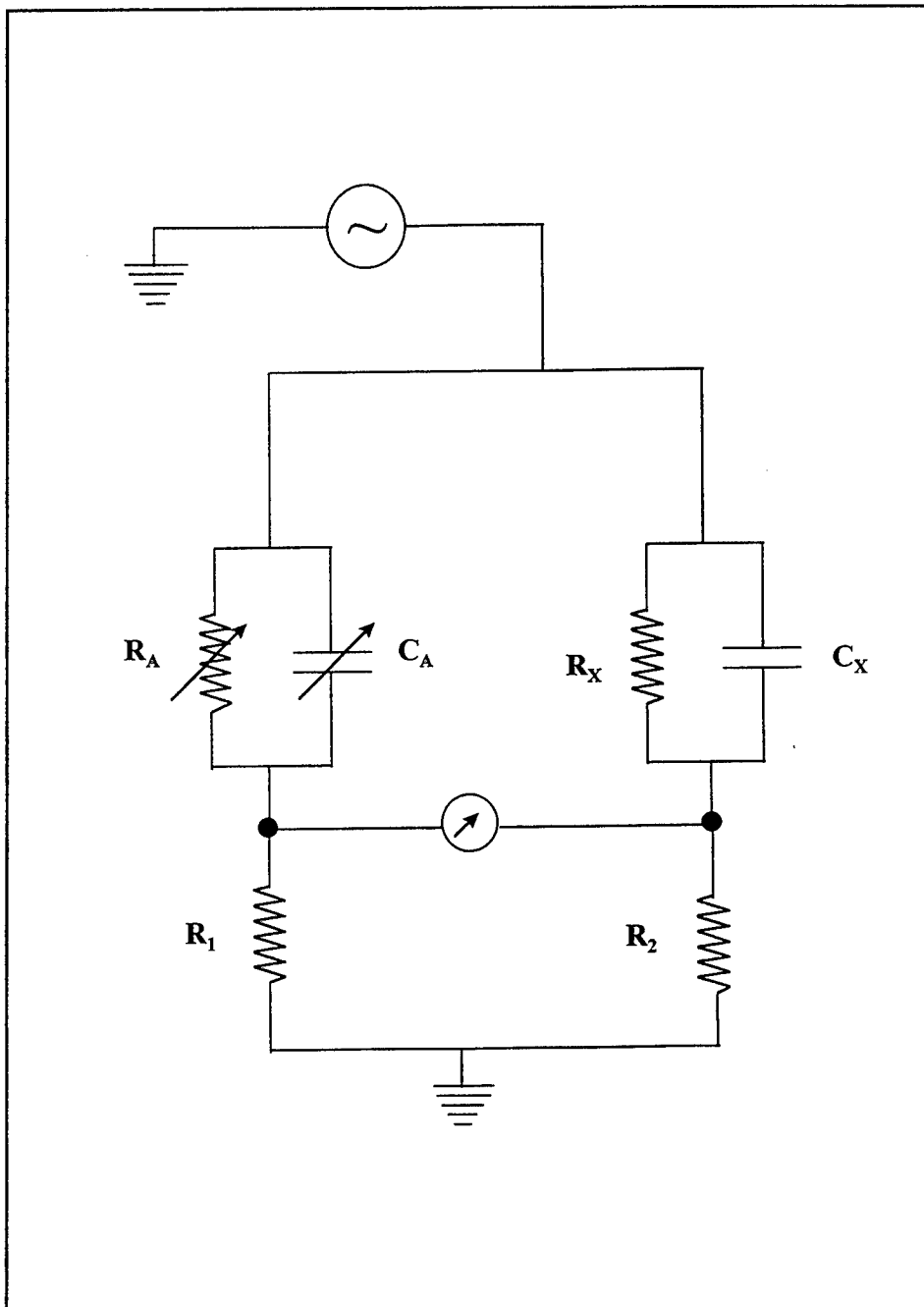

Figure A4. AC impedance bridge circuit used to determine resistance of concrete

where

$Z_X$  = unknown impedance

$Z_A$  = adjusted impedance

The equation for obtaining  $Z$  is (A21) on page A14.

### **Black box illustration**

What does it mean to say that fresh concrete is modeled electrically by a resistor and capacitor in parallel? Consider two black boxes. Let one box contain a resistor and a capacitor connected in parallel with an electrical lead from each end of the combination coming out of the black box. Only the leads would be visible on the outside of the box. Let the other box contain fresh mortar (or concrete) with two leads coming from a couple of electrodes contained within the concrete in the box. If an impedance measurement is made by connecting to the leads of either box, it would not be possible to tell by the electrical response from the impedance meter which box contained the concrete. Both black boxes would give similar responses. Therefore, a resistor and capacitor connected in parallel as shown by Figure A3 form an equivalent circuit for fresh concrete.

## **Complex Variables**

### **Resistance and reactance**

Impedance calculations require the mathematics of complex variables to describe the phenomenon. The complex number that represents the impedance of some circuit or equivalent circuit is made up of two parts, a real part and an imaginary part. Physically, the real part represents the measure of the resistance of the resistive portion of the impedance, and the imaginary part represents the measure of the reactance of the capacitance portion. (Reactance is the opposition to an AC current from a capacitor or inductor.) In other words, the real part represents the in-phase component; and the imaginary part, the out-of-phase component.

### **Phase relationships**

Unlike a resistor, the voltage and current through a capacitor or inductor are not in phase. The voltage lags the current by 90 deg for a capacitor. The voltage leads the current by 90 deg for an inductor, but fresh concrete does not exhibit any inductive properties, only capacitive. The resistance is plotted along the positive real axis, and the capacitive reactance is plotted along the negative imaginary axis. (See the vector diagram in Figure A5) The voltage can lag between 0 and -90 deg behind the total current of the parallel circuit for various combinations of resistance and capacitance. The combined opposition of resistance and reactance is called impedance. The Pythagorean theorem is used to calculate the magnitude of the impedance. The magnitude of the impedance is the length of the hypotenuse of the right angle formed from the real and imaginary components of the impedance.

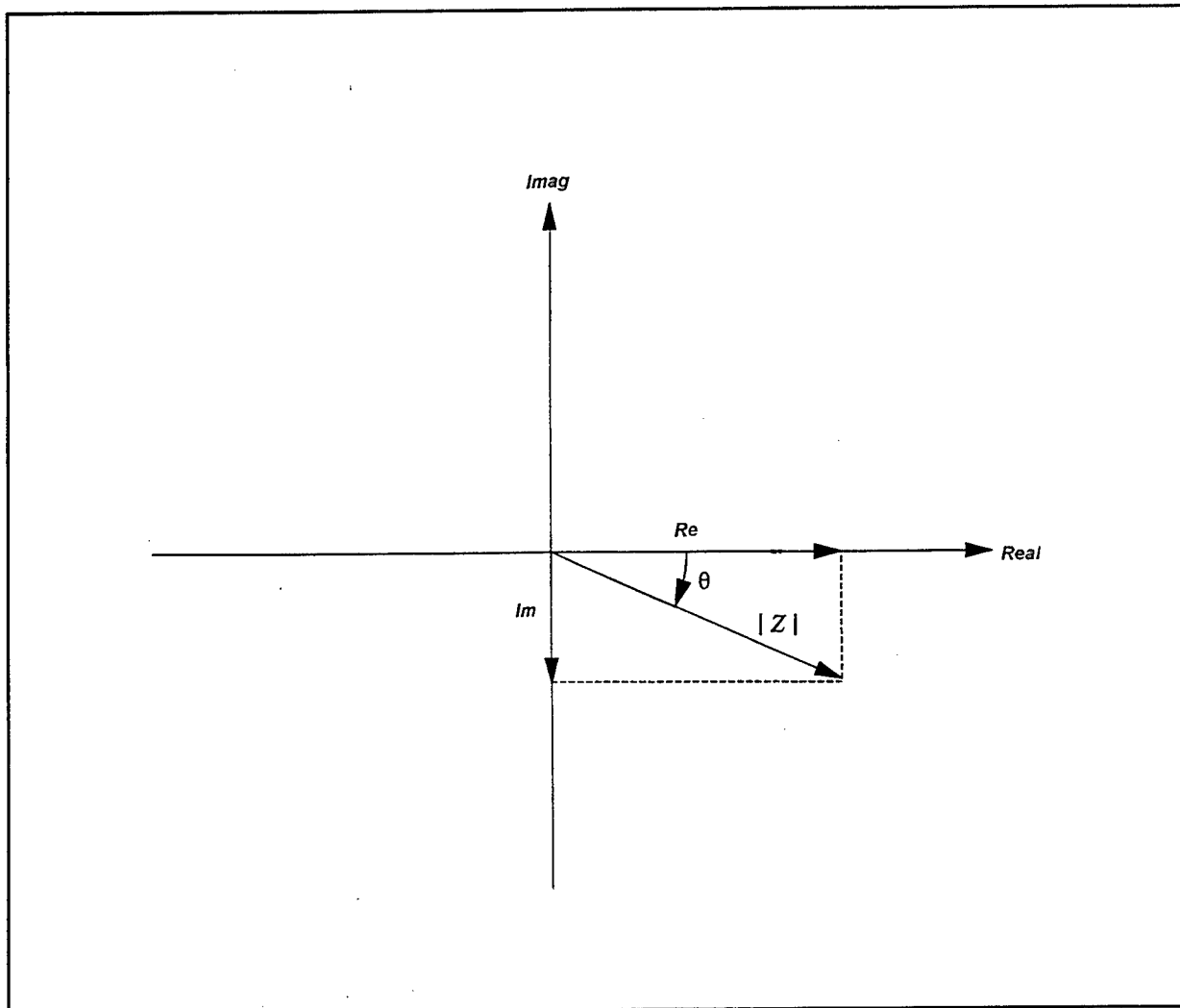

Figure A5. Relationship of magnitude and phase measurement on fresh concrete

### Mathematics to describe magnitude and phase

The impedance is the vector sum of the resistance and the reactance (Equation A11), and the magnitude is equal to the square root of the sum of the square of the resistance plus the square of the reactance (Equation A13). The phase angle is related to the magnitude of the resistance and reactive components (Equation A14) and is the angle between the impedance vector and the resistance vector. Because a resistor produces a 0-deg phase angle between the current and voltage and is plotted along the real axis, this horizontal line becomes the reference line for phase angle measurements. The impedance ( $Z$ ) can be expressed in rectangular coordinates consisting of the real and imaginary components of the impedance.

$$Z = Re + jIm \quad (A11)$$

where

$Re$  = real component of the impedance

$j$  = imaginary operator

$Im$  = imaginary component of the impedance

$$j = \sqrt{-1} \quad (A12)$$

or in terms of polar coordinates where the magnitude and phase angle are respectively:

$$|Z| = \sqrt{Re^2 + Im^2} \quad (A13)$$

and

$$\theta = ARCTAN \left( \frac{Im}{Re} \right) \quad (A14)$$

When calculating the phase angle ( $\theta$ ), the numerator is the imaginary component of the impedance, and the denominator is the real component of the impedance.

#### Derivation of impedance and phase angle

The circuit impedance ( $Z$ ) for a resistor and capacitor in parallel is:

$$\frac{1}{Z} = \frac{1}{R} + \frac{1}{-jX_C} \quad (A15)$$

where  $X_C$  is the capacitive reactance.

Obtaining a common denominator,

$$\frac{1}{Z} = \frac{-jX_C + R}{-jX_C R} \quad (A16)$$

Taking the reciprocal,

$$Z = \frac{jX_C R}{jX_C - R} \quad (A17)$$

Multiplying the numerator and denominator by the complex conjugate (value of one),

$$Z = \left( \frac{jX_C R}{jX_C - R} \right) \left( \frac{-jX_C - R}{-jX_C - R} \right) \quad (\text{A18})$$

Multiplying the terms and separating the real and imaginary components,

$$Z = \frac{X_C^2 R}{X_C^2 + R^2} - \frac{jX_C R^2}{X_C^2 + R^2} \quad (\text{A19})$$

The equation for calculating the capacitive reactance is:

$$X_C = \frac{1}{\omega C} \quad (\text{A20})$$

where  $\omega$  is the angular frequency in radians/second and  $C$  is the capacitance in farads.

Substituting actual component variables for the reactance,

$$Z = \frac{R}{1 + (R\omega C)^2} - \frac{j\omega C R^2}{1 + (R\omega C)^2} \quad (\text{A21})$$

This is the equation for calculating the impedance of a resistor and capacitor in parallel (equivalent circuit of fresh concrete), as shown in Figure A3. Now consider the bridge circuit of Figure A4. Calculating the ratio of impedances for the potentiometer on the left,

$$\frac{Z_A}{R_1} = \frac{\frac{R_A}{R_1}}{1 + (R_A \omega C_A)^2} - \frac{j\omega C_A \left( \frac{R_A^2}{R_1} \right)}{1 + (R_A \omega C_A)^2} \quad (\text{A22})$$

where the subscript A refers to the adjusted value.

Calculating the ratio of impedance for the potentiometer on the right,

$$\frac{Z_X}{R_2} = \frac{\frac{R_X}{R_2}}{1 + (R_X \omega C_X)^2} - \frac{j\omega C_X \left( \frac{R_X^2}{R_2} \right)}{1 + (R_X \omega C_X)^2} \quad (\text{A23})$$

When the bridge is balanced, the ratio on the left is equal to the ratio on the right. For two complex numbers to be equal, the real part of one number must equal the real part of the other number, and the imaginary parts must also correspond. Equating the imaginary parts of Equations A22 and 23, we get the following

$$-\frac{j\omega C_X \left( \frac{R_X^2}{R_2} \right)}{1 + (R_X \omega C_X)^2} = -\frac{j\omega C_A \left( \frac{R_A^2}{R_1} \right)}{1 + (R_A \omega C_A)^2} \quad (\text{A24})$$

and we see that

$$R_X = R_A, R_2 = R_1, C_X = C_A. \quad (\text{A25})$$

The magnitude and the phase angle of impedance in the concrete specimen are calculated as follows. Using Equation A13 stated earlier,

$$|Z| = \sqrt{Re^2 + Im^2} \quad (\text{A13 bis})$$

From Equation A21

$$Re = \frac{R_A}{1 + (R_A \omega C_A)^2} \quad (\text{A26})$$

and

$$Im = \frac{-\omega C_A R_A^2}{1 + (R_A \omega C_A)^2} \quad (\text{A27})$$

and substituting Equations A26 and A27 into Equation A13

$$|Z| = \frac{R_A}{\sqrt{1 + (R_A \omega C_A)^2}} \quad (\text{A28})$$

From Equation A14

$$\theta = ARCTAN \left( \frac{Im}{Re} \right) \quad (\text{A14 bis})$$

and substituting Equations A26 and A27 into Equation A14

$$\theta = ARCTAN (\omega C_A R_A) \quad (\text{A29})$$

# **Appendix B**

## **Procedure for Manual Ammeter-Voltmeter (MAV) Resistance Measurements and Constant-Volume Mass Measurement (CVMM)**

---

### **Testing Potential of Hypothesis Before Refining Measurement**

Use the MAV method to test the premise that the alternating current (AC) resistance of concrete is related to the time of vibration. Prepare a concrete mixture designed for a pavement. Overemphasize air content (add air or design low water to cement ratio (w/c) so that it will be easy for air voids to be created, by a shovel for example) initially so it can be seen if a distinct or pronounced relationship exists between the time of vibration and electrical resistance. For example, does the resistance drop 1 ohm when consolidated, or does it drop 100 ohms? Make up a large batch of concrete, and work only with a small volume each time to properly experiment with a mixture for a period of time without scheduling a new batch each time. Use a retarder to slow the hydration process.

### **Preparation of Container and Electrodes**

Prepare a 152-mm (6-in.) by 305-mm (12-in.) plastic cylinder mold for AC-resistance measurements. Install a 75-mm- (3-in.-) diam brass or copper shim electrode into the base of the cylinder. Do not use aluminum as it will react chemically with the concrete. Connect a lead from the bottom of the electrode through the base of the cylindrical mold. Bond the electrode in place with a

water-resistant adhesive. Use a thicker stock metal that is stiffer than the base electrode for constructing the top electrode. The bottom electrode is fixed in position, and the top electrode is removable. The test is conducted with the cylinder sitting on its base.

## Measurement

Refer to Figure 50 in the main text that shows the connections for the MAV method. Adjust the Wavetek function generator, Model 114, for an AC sine-wave output with the frequency at 1 kHz. Adjust the output for full output voltage ( $V_t$ ). The unloaded voltage from the Wavetek is about 11 volts but will drop to about 50 percent of the full voltage when the power supply is loaded by the specimen and current resistor. The supply voltage is applied across the specimen and the decade box, which are connected in series. Adjust the resistance decade box (current resistor) until the voltage across it is roughly 1/11 of the supply voltage. That will mean the resistance of the specimen is equal to 10 times the resistance of the current resistor ( $R_r$ ). At this point, do not make any further adjustments to the supply voltage and do not change the size of the current resistor during the conduction of the test. Measure and record the voltage across the current resistor ( $V_r$ ). Measure and record the voltage across the fresh concrete ( $V_c$ ). Measure and record the supply voltage ( $V_s$ ). Measure and record the mass of the specimen. Use a scale that can cover about 12,000 g of mass and has resolution to 0.1 g. Calculate the resistance of the specimen ( $R_c$ ) prior to any consolidation by vibration. Ohm's law is first applied to the current resistor to calculate the current in the series circuit; then it is applied to the concrete to determine its resistance. The current in the specimen can be found by calculating the current in the resistor since they both are in a series circuit.  $I = V_r/R_r$ . Then, the resistance of the specimen is equal to  $R_c = V_c/I$ . Enter all four numbers ( $V_r$ ,  $V_c$ ,  $V_s$ ,  $W_t$ ) into the spreadsheet.

## CVMM Technique

Place the cylinder containing the concrete on the shaker table with the vibration control at its lowest setting. The shaker table should produce a more uniform consolidation throughout the volume of the mortar than tapping the sides of the form with a rubber hammer. It needs to be uniform because the AC resistance being measured is the average resistance of the cementitious material between the 75-mm (3-in.) -diam electrodes.

- a. Activate the shaker table for approximately 1 sec to partially consolidate the concrete.
- b. Fill the cylinder to the top with fresh unconsolidated concrete to replace the volume of air that was released from the concrete during the partial consolidation.

- c. Screed the top surface of the cylinder, being careful to catch all the overflow concrete, and remove it from the mold so that it does not get weighed.
- d. Spread paste on the top electrode so that there is no air gap between the electrode and the concrete during the measurement. Position the free electrode on the top surface of the concrete and measure again the electrical parameters.
- e. Determine the mass of the partially consolidated concrete in the plastic cylinder. Always measure the parameters for AC-resistance and the mass for a full volume which ensures a full 305-mm (12-in.) distance between the electrodes. Use a high-resolution scale.
- f. Calculate the AC resistance as described above. Continue the process for as many times as necessary until no more air can be released.

## Static Measurements

The MAV method will not allow one to make measurements under dynamic conditions; it will allow measurements only under static conditions. That is, make the measurements before and after the vibrator is being used (static conditions) and not while the vibration is taking place (dynamic conditions). Insert the vibrator for a short interval or activate the shaker table for a similar time for each measurement so that numerous measurements can be made between interruptions of the vibrator before the consolidating process is completed. Retard the concrete mixture somewhat with the correct additive to give personnel more time to work with it.

## Conducting Experiment and Recording Data

Conduct the experiments so that measurements are gotten over a short time frame (less than 30 min) such that the time of hydration is not a variable. Note those quantities that are constants and those that are variables, record data, record dates and times of significant events in the experiments, record the type of equipment used, and enter the measurement numbers into neat tables. Be careful not to shake the container and cause partial consolidation before the first resistance measurement is made.

# Appendix C

## Procedure for Manual Wheatstone Bridge (MWB) Resistance Measurements

---

Turn on the Electro Scientific Industries (ESI) instrument and allow it to warm up for about 15 min. Turn the amplifier gain control clockwise. Refer to Figure 53 in the main text, which shows the function controls. The red lamp to the left will light. This turns on the instrument as well as provides some level of detector sensitivity. Also, turn the oscillator control clockwise (this switches on the bridge voltage and adjusts the amplitude level of bridge voltage) but not all the way clockwise to the direct current (DC) position. Also, turn on the oscilloscope and allow it to warm up.

Connect the two leads wires from the plastic cylinder mold to the L-R terminals of the ESI bridge. Connect one pair of ends of two lead wires to the capacitor decade box and tie the other pair of ends to the G connection and the high side of the L-R connection on the ESI bridge. This places the capacitor across the Dekastat<sup>TM</sup> resistor. Connect two lead wires to the two female banana connections on either side of the alternating current (AC) null indicator and connect the other pair of ends of the lead wires to the oscilloscope for detecting the null. Figure 54 in the main text shows the bridge connections. Raising the generator voltage rather than the oscilloscope gain can improve the signal-to-noise ratio.

Adjust the voltage sensitivity and the sampling rate on the oscilloscope until a suitable signal is displayed. Adjust the sampling rate such that 10 or 15 cycles can be seen on the scope. Adjust the sensitivity such that the signal covers 75 percent of the screen. To achieve a balance, adjust the known resistance and capacitance such that the voltage displayed on the screen of the scope is always decreasing toward a null. Decrease the range of the oscilloscope voltage and increase the sensitivity of the amplifier as a null (balance) is approached. Continue to adjust the resistance and capacitance of the meter for a null until the level of the noise prevents further adjustment.

Three dials are used to determine the value of the resistance: (a) circuit selector switch, (b) multiplier switch, and (c) main dial assembly. Start with the circuit selector switch on the x1 position for resistances less than 1.2 megohms. This resistor is 1K ohms. Set the multiplier switch on one of the seven resistance multipliers that will correspond to the expected resistance. Set the main dial on a value of 3.0 initially. The resistance of the unknown is equal to the product of the resistance of the arm containing the main dial Dekastat<sup>TM</sup>, 1/10 the resistance of the arm containing one of the seven range resistors and divided by the resistance of the arm containing one of the 1K ohm or 10K ohm standard resistors.

$$R_X = R_S \left( \frac{R_R}{R_M} \right)$$

Where

- $R_X$  = Resistance of the unknown, 30 to 400 ohms
- $R_S$  = Resistance of the main dial dekastat, 3.0 ohms
- $R_R$  = Resistance of the range resistor, 1000 ohms
- $R_M$  = Resistance of the multiplier resistor, 10 ohms

In effect, the same answer can be obtained in a simple manner by multiplying the value of the circuit selector switch (1 or 10) times the range value times the Dekastat<sup>TM</sup> reading. Although the labeled values differ from the actual resistance of the resistors by some integral multiply of 10, the values have been worked out to yield the correct answer by correcting for that factor.

Switch the detector switch to external detector so that the oscilloscope becomes the null detector rather than the magic eye detector. Flip the generator switch to internal AC so that power is supplied to the bridge from the on-board AC 40-V, 1-kHz power supply.

By adjusting the combination of scope sensitivity, amplifier gain, and oscillator output voltage, maximum sensitivity can be maintained. Adjust the amplifier gain and oscillator controls to about the center position initially. Adjust scope sensitivity such that the display is about 75 percent of full scale. As a null is approached, continue to increase one of the three parameters until the resistance and capacitance values cannot be divided further or until the noise level prevents further adjustment.

Before disconnecting the specimen, set the generator switch to external generator (center position). When finished with the bridge, set the amplifier switch to off.

# **Appendix D**

## **Calculations for Obtaining the Air-Content-Versus-Alternating- Current Resistance Curve**

---

**APPENDIX**  
**CALCULATIONS FOR DETERMINING THE AIR-CONTENT-VERSUS-AC-RESISTANCE CURVE**

<b>Measured Point</b>			
	Density lbs/ft		Air Content percent
D1=	124	A1=	15.6

<b>Calculated point</b>			
If the air content drops one percent the density will go up one percent			
D2=	125.24	A2=	14.6
			$A2 = A1 - 1\%$
			$D2 = D1 + (1\%)D1$

For the linear curve  $y=mx+b$  or in this case  $D=mA+D_0$

THE SLOPE (m) IS EQUAL TO  $(D2-D1)/(A2-A1)$        $m = -1.24$

THE D-INTERCEPT ( $D_0$ ) IS EQUAL TO  $D1-m(A1)$ .       $D_0 = 143.344$

THE FINAL EQUATION IS  $D=mA+D_0$

	Air Content (A) Percent	Density (D) Lbs/cu. ft.	
Measured pair	15.6	124.00	$D = m(A) + D_0$
	14.6	125.24	
	13.6	126.48	
$D(i) = D(i-1) - 1.0\%$	12.6	127.72	
	11.6	128.96	
	10.6	130.20	
	9.6	131.44	
	8.6	132.68	
	7.6	133.92	
	6.6	135.16	
	5.6	136.40	
	4.6	137.64	
	3.6	138.88	
	2.6	140.12	
	1.6	141.36	
	0.6	142.60	
	0	143.34	$D_0$

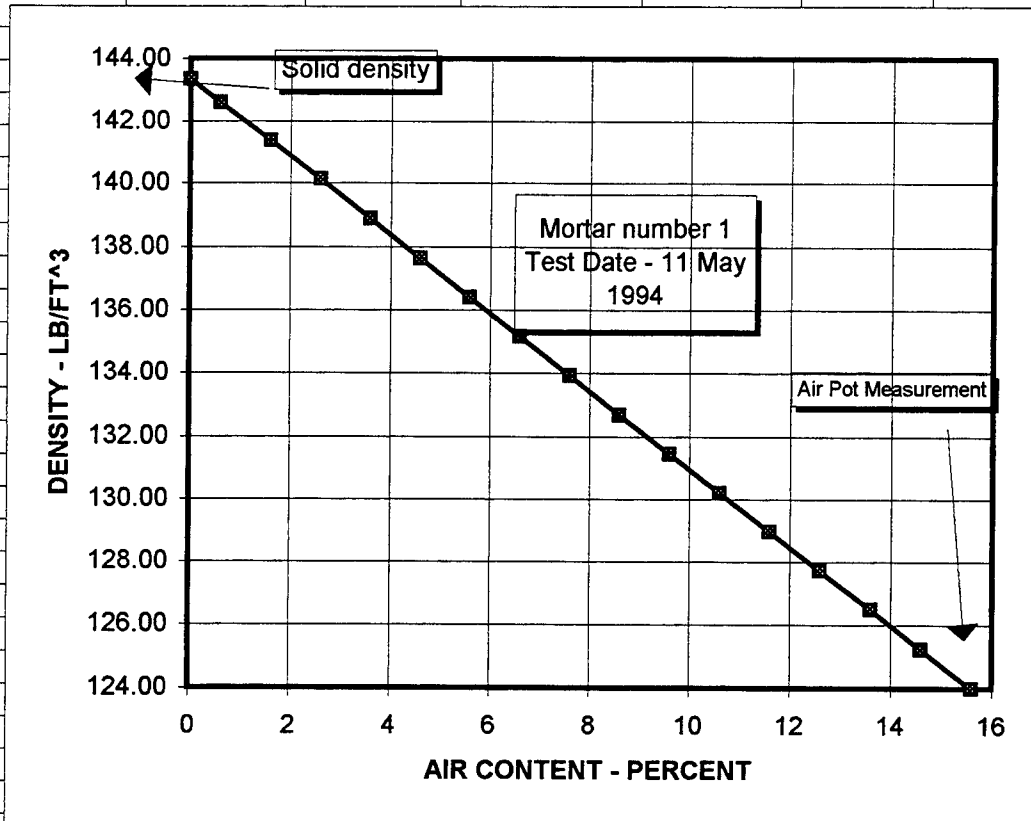

Length = 1 ft	Density = Weight / 453.6 / Volume and Volume = Length*PIE(Diameter^2)/4		Measured		
Diameter = 1/2 ft	Measured weight of fresh mortar in 6"-- diam X 12"- long plastic cylinder mold	Air content = (Density - Density intercept) / slope	Percent		
pie= 3.141592654					
	Meas	Weight	Density	Air	Spec
	Number	Grams	lbs/cubic ft	%	Resist Ohms
	1	11122.6	124.9	14.9	262.6
	2	11160.7	125.3	14.5	256.1
	3	11182.7	125.6	14.3	249.0
	4	11196.6	125.7	14.2	245.0
	5	11208.4	125.8	14.1	244.3
	6	11229.9	126.1	13.9	244.4
	7	11242.5	126.2	13.8	234.4
	8	11267.1	126.5	13.6	232.2
	9	11277.5	126.6	13.5	225.9
	10	11331.8	127.2	13.0	221.2
	11	11372.3	127.7	12.6	216.2

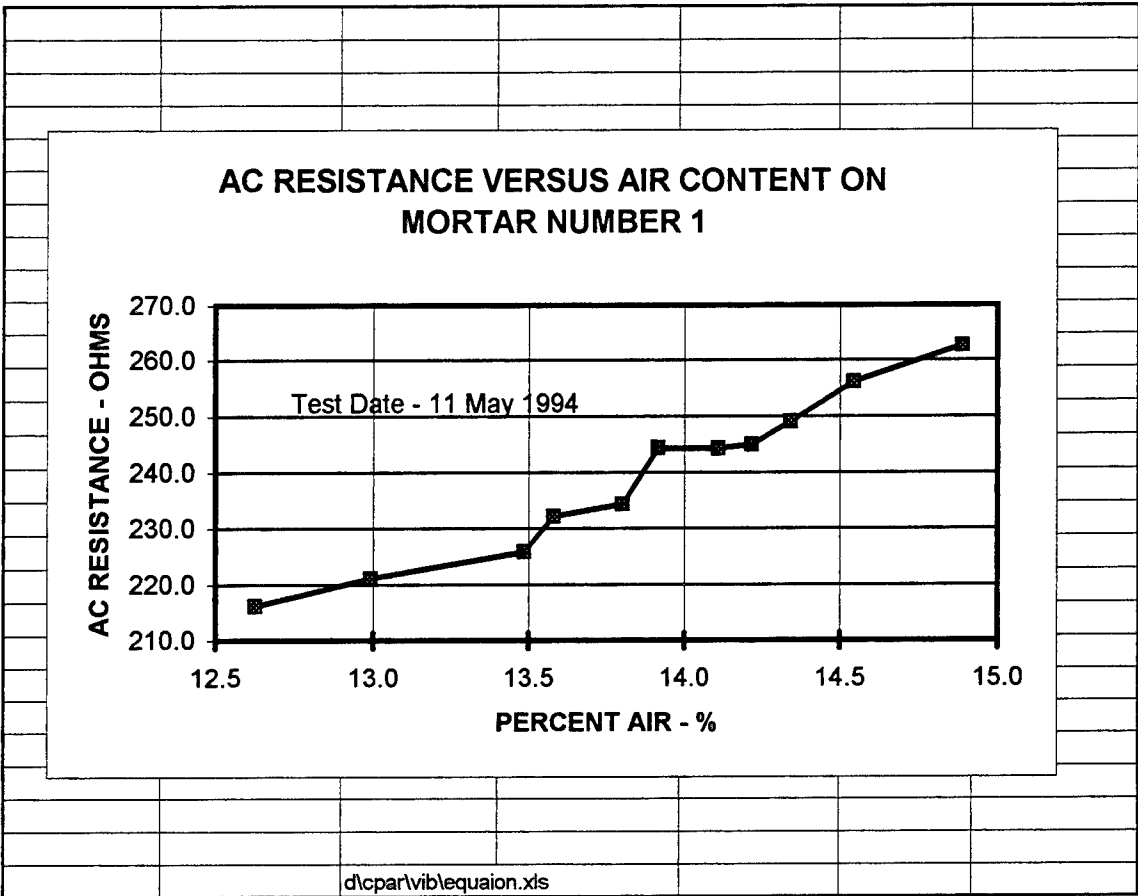

# REPORT DOCUMENTATION PAGE

Form Approved  
OMB No. 0704-0188

Public reporting burden for this collection of information is estimated to average 1 hour per response, including the time for reviewing instructions, searching existing data sources, gathering and maintaining the data needed, and completing and reviewing the collection of information. Send comments regarding this burden estimate or any other aspect of this collection of information, including suggestions for reducing this burden, to Washington Headquarters Services, Directorate for Information Operations and Reports, 1215 Jefferson Davis Highway, Suite 1204, Arlington, VA 22202-4302, and to the Office of Management and Budget, Paperwork Reduction Project (0704-0188), Washington, DC 20503.

<b>1. AGENCY USE ONLY (Leave blank)</b>		<b>2. REPORT DATE</b> September 1997	<b>3. REPORT TYPE AND DATES COVERED</b> Final report	
<b>4. TITLE AND SUBTITLE</b>  New Technologies for Improving the Consolidation of Concrete			<b>5. FUNDING NUMBERS</b>	
<b>6. AUTHOR(S)</b>  A. Michel Alexander, Richard W. Haskins, Al Sari, Parviz Soroushian, Jer-Wen Hsu				
<b>7. PERFORMING ORGANIZATION NAME(S) AND ADDRESS(ES)</b>  U.S. Army Engineer Waterways Experiment Station, 3909 Halls Ferry Road, Vicksburg, MS 39180-6199; Innotech International, Inc., 1232 Mizzen Drive, Okemos, MI 48864			<b>8. PERFORMING ORGANIZATION REPORT NUMBER</b>  Technical Report CPAR-SL-97-2	
<b>9. SPONSORING / MONITORING AGENCY NAME(S) AND ADDRESS(ES)</b>  U.S. Army Corps of Engineers, Washington, DC 20314-1000			<b>10. SPONSORING / MONITORING AGENCY REPORT NUMBER</b>	
<b>11. SUPPLEMENTARY NOTES</b>  Available from National Technical Information Service, 5285 Port Royal Road, Springfield, VA 22161.				
<b>12a. DISTRIBUTION / AVAILABILITY STATEMENT</b>  Approved for public release; distribution is unlimited.			<b>12b. DISTRIBUTION CODE</b>	
<b>13. ABSTRACT (Maximum 200 words)</b>  Under the Construction Productivity Advancement Research (CPAR) Program, a new two-part system for improving the consolidation of concrete has been developed. First, a new vibratory consolidation subsystem was developed to enhance the efficiency and effectiveness of concrete consolidation in the context of a slipform paver. The system uses the phenomenon of resonance to efficiently vibrate a rigid and relatively large consolidation volume within concrete to relatively high-vibratory displacement amplitudes at a frequency appropriate for concrete consolidation. Dynamic finite-element analysis and optimization techniques were used to design a mechanical system based on this concept which also satisfied the geometric requirement for installment in slipform pavers. The vibratory consolidation subsystem was then constructed, evaluated, and subjected to a comparative experimental study which revealed its advantages over conventional internal vibrators. A strain-gauge monitoring system was also devised and evaluated for real-time monitoring of the consolidation process of concrete under the action of the new system. A connection mechanism to interface between the new consolidation system and slipform pavers was devised, manufactured, and installed on a slipform paver. A large-scale field simulation was constructed for the purpose of evaluating the whole connection system under realistic operating conditions that closely simulated those of slipform pavers. Refinement of  <div style="text-align: right;">(Continued)</div>				
<b>14. SUBJECT TERMS</b>			<b>15. NUMBER OF PAGES</b> 126	
			<b>16. PRICE CODE</b>	
<b>17. SECURITY CLASSIFICATION OF REPORT</b>  UNCLASSIFIED	<b>18. SECURITY CLASSIFICATION OF THIS PAGE</b>  UNCLASSIFIED	<b>19. SECURITY CLASSIFICATION OF ABSTRACT</b>	<b>20. LIMITATION OF ABSTRACT</b>	

13. (Concluded).

the hydraulic control and cooling system of the shakers that drive the resonant vibrators is going on currently. This will be followed by long-term longevity and fatigue evaluation of the complete system under realistic operation conditions on a slipform paver.

Second, significant progress was made in the development of the other subsystem. It is an electrical impedance device that provides results in real-time for measuring the degree of consolidation of concrete during vibration for mechanical pavers. The device operates on the principle that since air is an insulator and fresh concrete is a conductor, electrical impedance measurements can detect the release of air during the consolidation of fresh concrete. When the entrapped air is released from the fresh concrete through the process of vibration, then the alternating-current impedance of the concrete drops in value. Two prototype consolidation meters appropriate for the field were constructed. The device is simple to operate, portable, battery-powered, and noise resistant. The heart of the device is based on the impedance bridge. Fresh concrete has been found to be equivalent to a parallel resistor-capacitor circuit in terms of its electrical response. Limited tests indicate that the entrapped air is released at a faster rate than entrained air, creating two distinct parts to the alternating-current-resistance-against-time-of-vibration curve. The intersection of these two parts of the curve represents the point in time at which consolidation is complete. The system has a 0- to 15-V analog meter to indicate that point of completion. Before paving begins, a couple of zero-controls on the front panel of the meter are adjusted so that the analog needle falls on zero volts to represent the impedance of the unconsolidated concrete. Then, that same volume of concrete is consolidated before the paver begins to move, and the gain control on the front panel is adjusted to represent the consolidated impedance on a full-scale setting of 15-V. The setting is arbitrary. When the paver begins to move at a rate sufficient to maintain the meter near the full-scale setting, then the entrapped air has been removed, and only the entrained air remains. The concrete has been properly consolidated. The system has not yet been tested in the field on a slipform paver. Provisional plans are for CMI of Oklahoma City, OK, to commercialize both subsystems assuming they follow through with their stated purpose within a reasonable time frame.