



EDGEWOOD

RESEARCH, DEVELOPMENT & ENGINEERING CENTER

U.S. ARMY CHEMICAL AND BIOLOGICAL DEFENSE COMMAND

ERDEC-CR-231

**MEASUREMENT OF ADSORPTION EQUILIBRIA
FOR 2,2-DICHLORO-1,1,1-TRIFLUOROETHANE
ON ACTIVATED CARBON**

**Amanda B. Brady
Todd M. Wilson
David K. Friday**

**GUILD ASSOCIATES, INC.
Baltimore, MD 21236**

THIS QUANTITY INSPECTED 4

July 1997

Approved for public release; distribution is unlimited.



Guild
Associates, Inc.



19971117 064

Aberdeen Proving Ground, MD 21010-5423

Disclaimer

The findings in this report are not to be construed as an official Department of the Army position unless so designated by other authorizing documents.

REPORT DOCUMENTATION PAGE			Form Approved OMB No. 0704-0188	
Public reporting burden for this collection of information is estimated to average 1 hour per response, including the time for reviewing instructions, searching existing data sources, gathering and maintaining the data needed, and completing and reviewing the collection of information. Send comments regarding this burden estimate or any other aspect of this collection of information, including suggestions for reducing this burden, to Washington Headquarters Services, Directorate for Information Operations and Reports, 1215 Jefferson Davis Highway, Suite 1204, Arlington, VA 22202-4302, and to the Office of Management and Budget, Paperwork Reduction Project (0704-0188), Washington, DC 20503.				
1. AGENCY USE ONLY (Leave Blank)	2. REPORT DATE 1997 July	3. REPORT TYPE AND DATES COVERED Final; 94 Aug - 95 May		
4. TITLE AND SUBTITLE Measurement of Adsorption Equilibria for 2,2-Dichloro-1,1,1-Trifluoroethane on Activated Carbon		5. FUNDING NUMBERS C-DAAA15-93-C-0070		
6. AUTHOR(S) Brady, Amanda B.; Wilson, Todd M.; and Friday, David K.				
7. PERFORMING ORGANIZATION NAME(S) AND ADDRESS(ES) Guild Associates, Inc., 5022 Campbell Boulevard, Baltimore, MD 21236		8. PERFORMING ORGANIZATION REPORT NUMBER ERDEC-CR-231		
9. SPONSORING/MONITORING AGENCY NAME(S) AND ADDRESS(ES) DIR, ERDEC, ATTN: SCBRD-RT/ASM, APG, MD 21010-5423		10. SPONSORING/MONITORING AGENCY REPORT NUMBER		
11. SUPPLEMENTARY NOTES COR: David Reed, SCBRD-RT/ASM, (410) 671-8212				
12a. DISTRIBUTION/AVAILABILITY STATEMENT Approved for public release; distribution is unlimited.		12b. DISTRIBUTION CODE		
13. ABSTRACT (Maximum 200 words) Adsorption equilibria were measured for 2,2-dichloro-1,1,1-trifluoroethane (R-123) on BPL activated carbon at three temperatures (348, 398, and 448 K) over a wide range of partial pressures. Special care was given to developing a system to accurately measure equilibria data at elevated temperatures. The data is compared to isotherm equilibria data measured under the same conditions using a different apparatus at the U.S. Army Edgewood Research Development and Engineering Center (ERDEC).				
14. SUBJECT TERMS Isotherm R-123		Activated carbon Adsorption equilibria		15. NUMBER OF PAGES 17
				16. PRICE CODE
17. SECURITY CLASSIFICATION OF REPORT UNCLASSIFIED	18. SECURITY CLASSIFICATION OF THIS PAGE UNCLASSIFIED	19. SECURITY CLASSIFICATION OF ABSTRACT UNCLASSIFIED	20. LIMITATION OF ABSTRACT UL	

Blank

PREFACE

The work described in this report was authorized under Contract No. DAAA15-93-C-0070. This work was started in August 1994 and completed in May 1995.

The use of either trade or manufacturers' names in this report does not constitute an official endorsement of any commercial products. This report may not be cited for purposes of advertisement.

This report has been approved for public release. Registered users should request additional copies from the Defense Technical Information Center; unregistered users should direct such requests to the National Technical Information Service.

Blank

CONTENTS

1.	INTRODUCTION.....	7
2.	EXPERIMENTATION.....	7
2.1	Isotherm Measurement Apparatus	7
2.2	Materials.....	8
3.	PROCEDURE.....	8
4.	EXPERIMENTAL RESULTS.....	9
5.	CONCLUSIONS.....	10

FIGURES

1	Isotherm Apparatus	11
2	Bed and Jacket Assembly.....	12
3	Equilibria Data for R-123 on BPL Carbon at 348, 398 and 448 K.....	13
4	Equilibria Data for R-123 on BPL Carbon at 348 K, Comparison of Data Measured by Guild Associates, Inc. and ERDEC.....	14
5	R-123 on BPL Activated Carbon Isotherm Data with the Best Fit 5-parameter Virial Equation.....	15
6	High Temperature Isotherm Data for R-123/BPL Carbon Compared to Virial Equation Correlated Using 25, 50, 75C Isotherm Data	16

TABLES

1	Adsorption Isotherm Data for R-123 on BPL Activated Carbon.....	17
2	Equilibria Data for R-123 on BPL Carbon at 348 K Comparison of Data Measured by Guild Associates, Inc. and ERDEC	17

MEASUREMENT OF ADSORPTION EQUILIBRIA FOR 2,2-DICHLORO-1,1,1-TRIFLUOROETHANE ON ACTIVATED CARBON

1. INTRODUCTION

Accurate adsorption equilibria data are required in order to design and properly size adsorption-based separation or purification systems. There has been some success in reporting and correlating equilibria data at relatively low temperatures (i.e., 298, 323 and 348 K) over a fairly wide range of partial pressure for high to medium volatility vapors. However, there is less data in the literature for these same vapors at higher temperatures. These data are of particular interest in the design and development of temperature swing adsorption (TSA) systems, as well as any other system where adsorption is occurring at high temperatures. This study seeks to characterize equilibria behavior for 2,2-dichloro-1,1,1-trifluoroethane (R-123) on BPL activated carbon at elevated temperatures.

2. EXPERIMENTATION

2.1 Isotherm Measurement Apparatus.

A schematic of the apparatus used to measure the adsorption equilibria of R-123 on BPL carbon is shown in Figure 1. The system is similar to the apparatus used by Mahle, Buettner and Friday¹ with several modifications.

In order to achieve and maintain elevated temperatures at the bed, a novel bed assembly is used. Details of the bed assembly are shown in Figure 2. The adsorbent bed slips down inside a quartz tube. Nichrome heat tape, which is sealed inside the quartz tube, is used to attain and maintain elevated temperatures of up to 448 K. A 2 LPM purge bleed is passed down the inner length of the tube to facilitate heat transfer as well as eliminate hot spots during the cycling of the heat tape. The tubing above the bed is coiled to allow the challenge stream to equilibrate at the same temperature as the bed before passing over the adsorbent. In order to fit the coiled tubing inside the narrow diameter of the inner tube, 1/8" stainless steel tubing is used as compared to the 1/4" tubing used by Mahle, et al.

The tube containing the heat tape slips inside an outer jacket. During lower temperature runs, the jacket can be used as a water jacket for temperature control. At elevated temperatures a vacuum is pulled on the jacket to provide a measure of insulation against ambient

¹ Mahle, J.J., Buettner, L.C., and Friday, D.K., "Measurement and Correlation of the Adsorption Equilibria of Refrigerant Vapors on Activated Carbon," Ind. Eng. Chem. Res., Vol. 33, pp. 346-354 (1994).

temperature effects. To further protect the apparatus from the effects of room temperature, the entire assembly is insulated with rock fiber pipe insulation.

A 2 μ stainless steel sintered filter by Nupro is used in the system downstream from the bed assembly in order to limit the occurrence of dust in the system. It has proven quite effective. However, the combination of the 1/8" tubing and the filter causes a pressure drop in the system. Therefore, a pressure sensor was placed in the system as closely as possible to the GC sampling valve in order to measure the pressure in the sample loop at the time each sample is taken from the vapor phase.

Finally, the temperature control itself is different from the system used by Mahle, et al. At higher temperatures, instead of a temperature bath, an Omega controller is used in conjunction with a thermocouple placed just below the bed. A set point is downloaded to the controller from the computer. The controller ramps the temperature to the desired set point. A second thermocouple at the outlet of the bed is wired to the computer to verify the temperature at the bed and provide a safety shutdown mechanism in the event of overheating.

Parameter Values for Gas Chromatograph	
Oven Temperature	75 °C
Detector Temperature	250 °C
Carrier Gas	Nitrogen
Carrier Flow Rate	30 cc/min
Air Flow Rate	32 cc/min
Hydrogen Flow Rate	425 cc/min

2.2 Materials

The adsorbate in this study was 2,2-dichloro-1,1,1-trifluoroethane (R-123) manufactured by DuPont Corporation. The adsorbent was 12 x 30 mesh BPL activated carbon, Lot No. 7816-V, from Calgon Corporation.

3. PROCEDURE

The carbon is placed in a desiccator for 72 hours to remove residual water. A sample of carbon, approximately 0.5g, is placed in a vessel which has high pressure nitrogen blown through it in order to remove dust from the carbon. The sample is then weighed and placed in the sample holder, which is inserted into the main circulation loop. The system is then pressurized to 1000 torr for 10 minutes and monitored to detect any measurable pressure change in the system, i.e., 1/2 torr.

When the system has been purged clean, and the adsorbent successfully loaded into the system, the operator accesses and modifies the set-up file. The set-up file includes the mass and type of adsorbent used, volume of the system, GC calibration data, target masses to be injected into the system, desired temperature set points for the experiment, wait times, and equilibria criteria. Once the program has been started, the experiment continues under computer control.

The system operation is very similar to that of the Mahle, Buettner, Friday system mentioned previously, again with the exception of the temperature control. With the system in the bed bypass mode, chemical is injected into the system until the first target mass is reached. The computer then waits a user specified length of time before sampling the vapor phase to measure the vapor phase concentration in the system. If the mass is less than 75% of the target mass, more chemical is injected into the system. If the mass is within 25% of the target mass, the system is changed to the bed challenge mode, which directs the chemical stream over the adsorbent.

After the system has been placed in the challenge mode, the computer waits a predetermined length of time for equilibration before sampling the vapor phase. Sampling continues at a user defined time interval until the equilibria criteria have been satisfied. Once the system has equilibrated, the loading is calculated and equilibration is started at the next temperature set point. When isotherm equilibria points have been measured at each desired temperature, the system is again placed in the bed bypass mode and more chemical is injected until the next target mass is reached. This continues until equilibria points have been measured for all target masses at each temperature. (For more detail about the system operation consult Mahle, et al.)

4. EXPERIMENTAL RESULTS

Results of the high temperature experiments are shown in Figure 3. The data follow the expected pattern, with the lowest temperature run, 348 K, having the highest loadings and the highest temperature run, 448 K, having the lowest loadings. At 348 and 398 K, the loading of the second point is a little lower than the curve between the first and third points would indicate it should be. It is believed that this behavior is a result of the first points of each isotherm being higher than they should be. This behavior is due to the difficulty in accurately measuring concentrations, possibly due to the system not being fully equilibrated.

Upon taking a close look at the data measured at 448 K, one notices that every second point is slightly higher in loading than its preceding point. This phenomena is attributed to the effects of subtle changes in temperature at elevated temperatures. Because the temperature program started at the highest temperature, i.e. 448 K, each second point at 448 K has had a longer time period to reach and equilibrate at the desired temperature. In the future, longer wait

times and tighter equilibria criteria will hopefully insure that the system has equilibrated before the program accepts an equilibria point.

Figure 4 is a plot comparing the R-123 data at 348 K measured by ERDEC and Guild Associates, Inc. The data are in fairly close agreement considering that different systems were used to measure each set of data, particularly with respect to the temperature control. The results measured at Guild Associates, Inc. for R-123 on BPL carbon at 348 K are slightly higher in loading than those pints measured at ERDEC. This is possibly a result of a slight difference in the actual bed temperatures between the two experiments. (Guild Associates, Inc. data is measured at a higher temperature.)

Shown in Figure 5 is a five-parameter virial equation correlation of the low temperature (298 K, 323 K, and 348 K) isotherm data measured at ERDEC. The parameter values for this correlation were: $K_0 = 20.240$, $K_1 = -7134.5$, $B_1 = 13594$, $C_1 = -39117$, and $D_1 = 45762$. A test of the capability of the virial equation to estimate isotherm data outside of the temperature range measured is demonstrated in Figure 6. The Guild Associates, Inc. high temperature data is compared to "predicted" results of the five-parameter virial. This comparison shows that the five-parameter virial does a reasonable job of estimating the performance outside the temperature range. This may be important for those chemicals where measuring isotherm data at higher temperatures is more difficult (e.g., reactive chemical vapors).

5. CONCLUSIONS

An experimental system capable of measuring isotherm data at temperature well above 373 K has been developed.

Based on the R-123/BPL results, the virial equation may be used to estimate isotherm data outside of the measured temperature range.

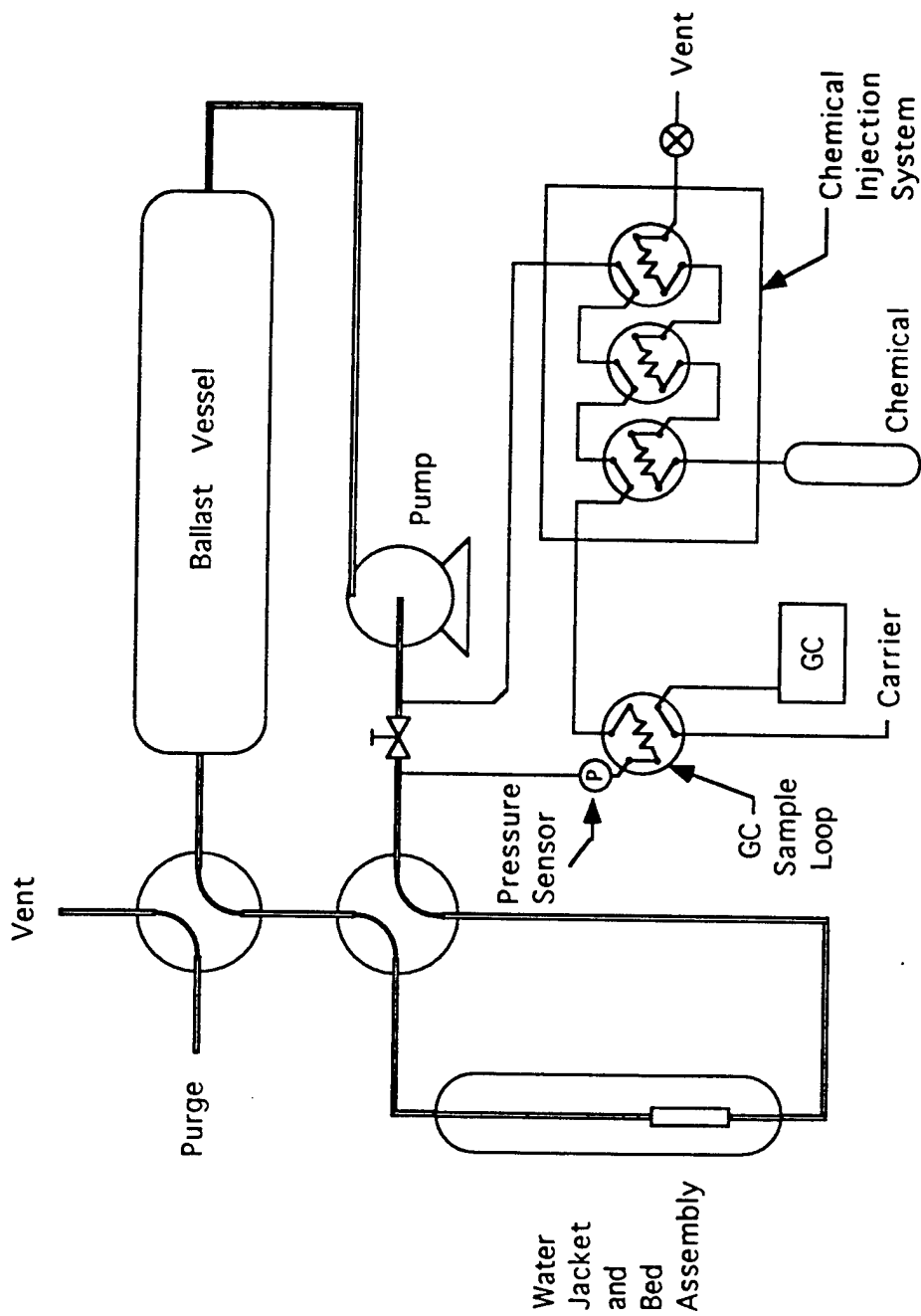

Figure 1. Isotherm Apparatus

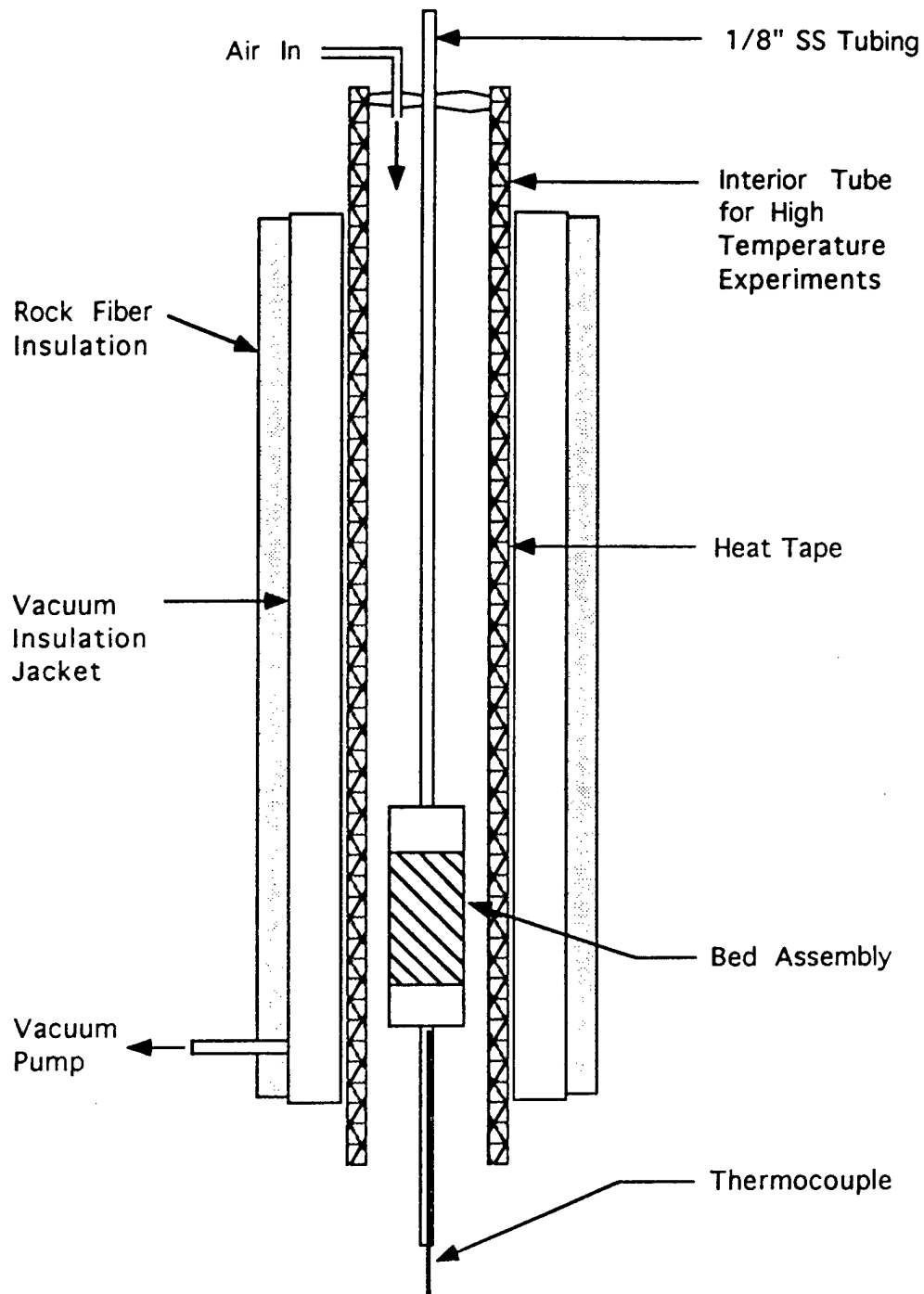

Figure 2. Bed and Jacket Assembly

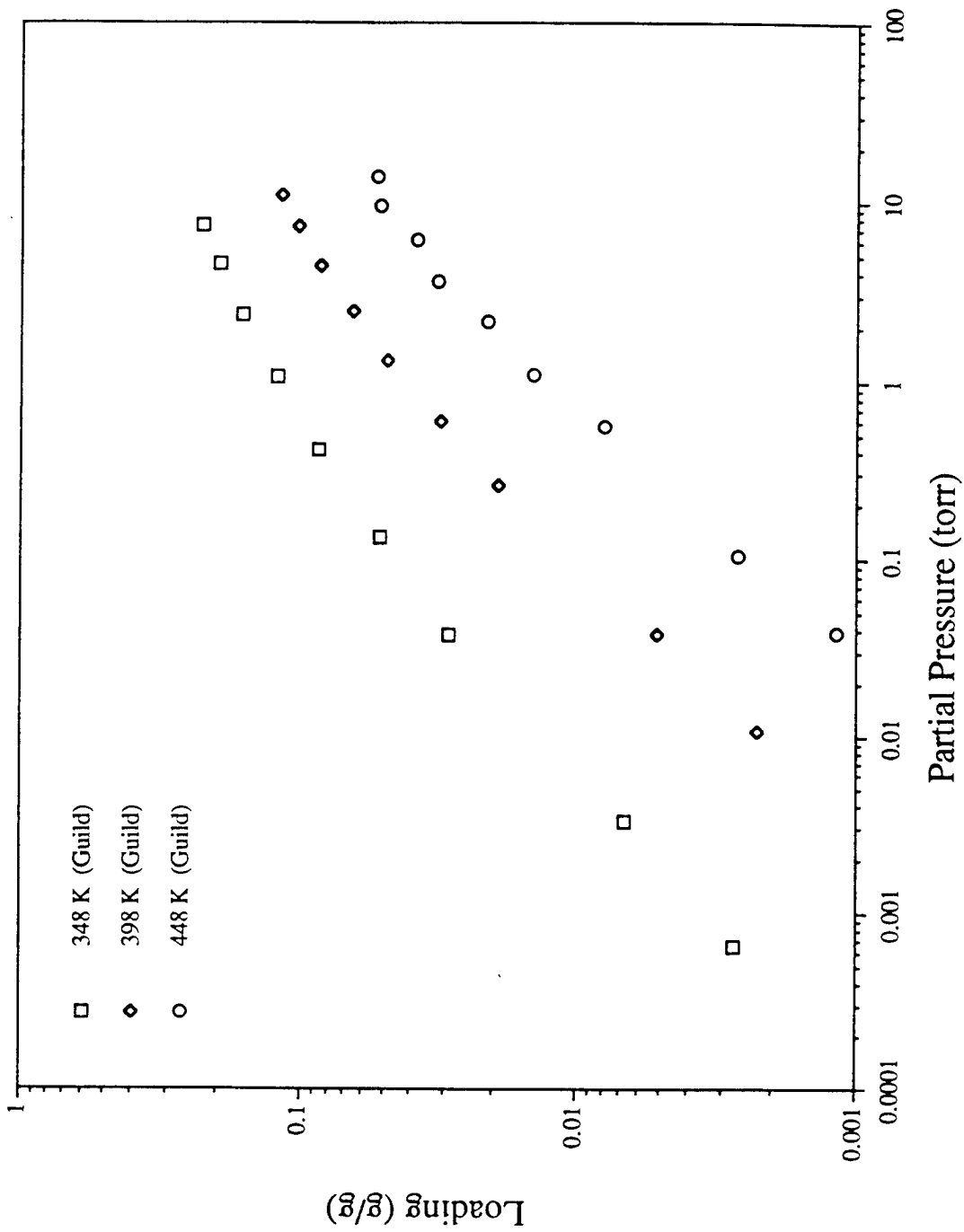
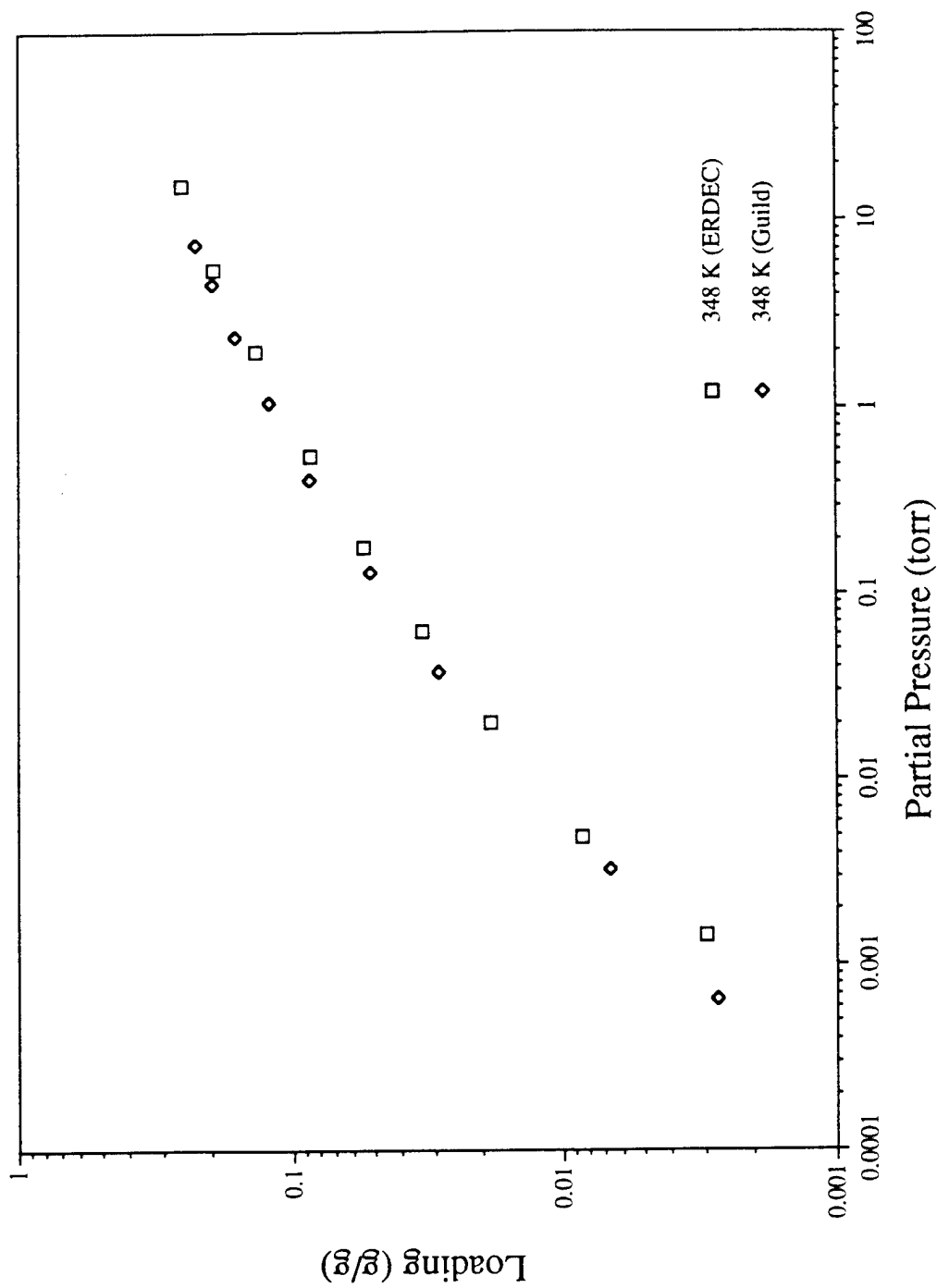

Figure 3. Equilibria Data for R-123 on BPL Carbon at 348, 398 and 448 K



**Figure 4. Equilibria Data for R-123 on BPL Carbon at 348 K
Comparison of Data Measured by Guild Associates, Inc.
and ERDEC**

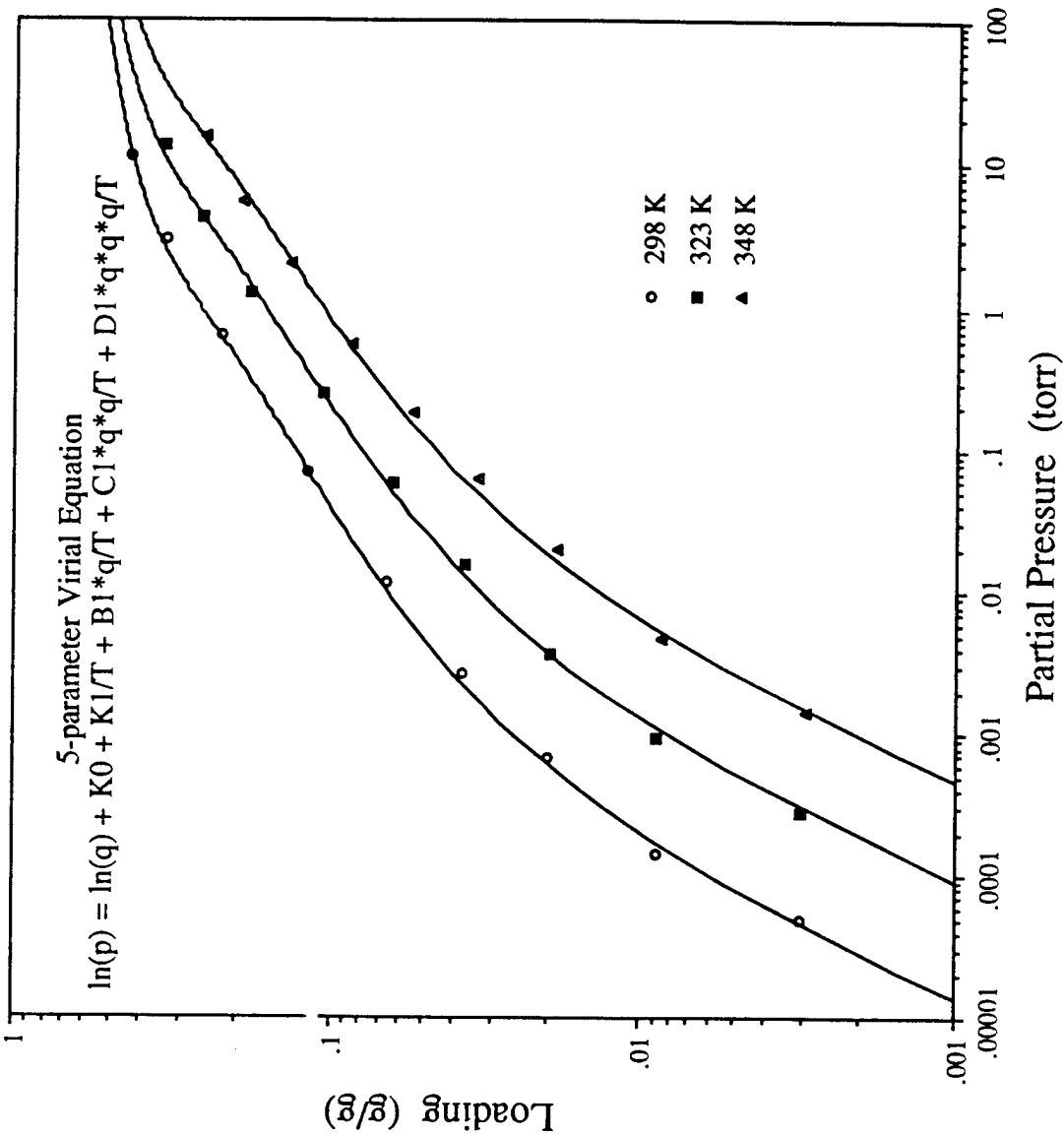

Figure 5. R-123 on BPL Activated Carbon Isotherm Data (symbols) with the Best Fit 5-parameter Virial Equation (lines)

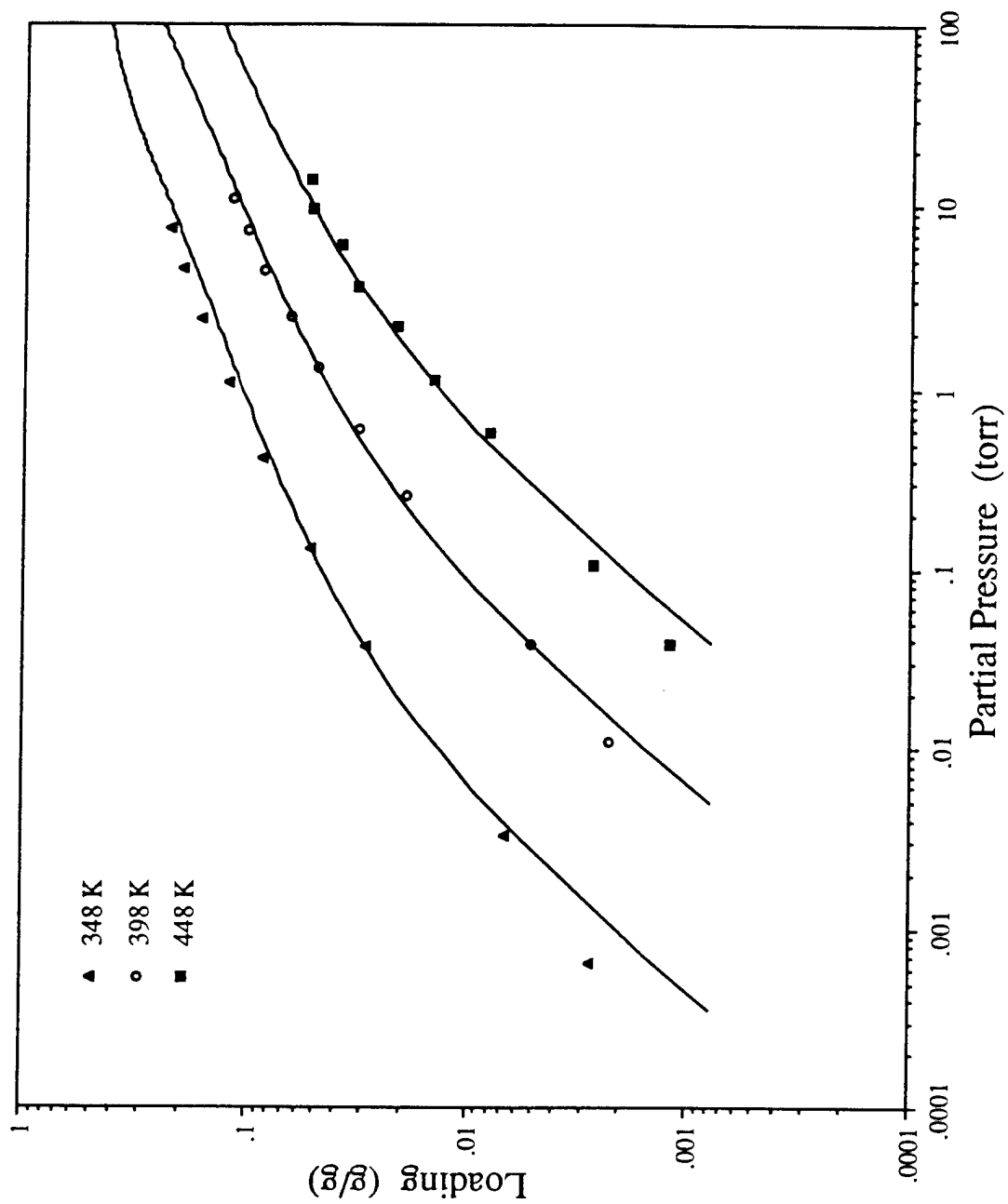

Figure 6. High Temperature Isotherm Data for R-123/BPL Carbon Compared to Virial Equation Correlated Using 25, 50, 75C Isotherm Data

Table 1. Adsorption Isotherm Data for R-123 on BPL Activated Carbon

348 K		398 K		448 K	
p(torr)	q(g/g)	p(torr)	q(g/g)	p(torr)	q(g/g)
6.5141e-4	2.7130e-3	3.8048e-2	5.1340e-3	3.5971e+0	3.2097e-2
3.2859e-3	6.6970e-3	2.5742e-1	1.9238e-2	9.4686e+0	5.2145e-2
3.7751e-2	2.9000e-2	6.0448e-1	3.1197e-2	1.3875e+1	5.3502e-2
1.3138e-1	5.1900e-2	2.4678e+0	6.5351e-2	3.8760e-2	1.1770e-3
4.1559e-1	8.6950e-2	7.2937e+0	1.0332e-1	1.0443e-1	2.6372e-3
1.0671e+0	1.2220e-1	1.0906e+1	1.1855e-1	5.6796e-1	7.9607e-3
2.3719e+0	1.6280e-1	1.0837e-2	2.2533e-3	1.0943e+0	1.4414e-2
4.5778e+0	1.9710e-1	1.3109e+0	4.8867e-2	2.1604e+0	2.1090e-2
7.4711e+0	2.2620e-1	4.4013e+0	8.5905e-2	6.1276e+0	3.8255e-2

Table 2. Equilibria Data for R-123 on BPL Carbon at 348 K
Comparison of Data Measured by Guild Associates, Inc. and ERDEC

348 K Guild		348 K ERDEC	
p(torr)	q(g/g)	p(torr)	q(g/g)
6.5141e-4	2.7130e-3	1.4184e-3	2.9800e-3
3.2859e-3	6.6970e-3	4.8935e-3	8.5100e-3
3.7751e-2	2.9000e-2	2.0198e-2	1.8580e-2
1.3138e-1	5.1900e-2	6.2055e-2	3.3410e-2
4.1559e-1	8.6950e-2	1.8005e-1	5.4750e-2
1.0671e+0	1.2220e-1	5.5512e-1	8.6180e-2
2.3719e+0	1.6280e-1	1.9902e+0	1.3645e-1
4.5778e+0	1.9710e-1	5.4649e+0	1.9457e-1
7.4711e+0	2.2620e-1	1.5414e+1	2.5425e-1