

NPS-ME-97-006

# NAVAL POSTGRADUATE SCHOOL Monterey, California



19971119 035

**Development of a Shell Element with Pressure  
Variation Through the Thickness**

by

Young K. Kwon

May 1, 1997 - September 30, 1997

Approved for public release; distribution is unlimited.

Prepared for: Naval Surface Warfare Center  
Carderock, MD 20817

UNCLASSIFIED

Naval Postgraduate School  
Monterey, California

Real Admiral M. J. Evans  
Superintendent

R. S. Elster  
Provost

This report was prepared in conjunction with research conducted for Naval Surface Warfare Center, Carderock Division.

This report was prepared by:



---

Young W. Kwon  
Associate Professor of Mechanical Engineering

Reviewed by:



---

T. R. McNelley  
Chairman  
Dept. of Mechanical Engineering

Released by:

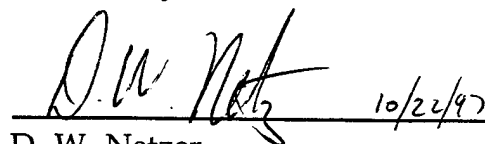
 10/22/97

---

D. W. Netzer  
Dean of Research

REPORT DOCUMENTATION PAGE			Form Approved OMB No. 0704-0188	
Public reporting burden for this collection of information is estimated to average 1 hour per response, including the time for reviewing instructions, searching existing data sources, gathering and maintaining the data needed, and completing and reviewing the collection of information. Send comments regarding this burden estimate or any other aspect of this collection of information, including suggestions for reducing this burden to Washington Headquarters Services, Directorate for Information Operations and Reports, 1215 Jefferson Davis Highway, Suite 1204, Arlington, VA 22202-4302, and to the Office of Management and Budget, Paperwork Reduction Project (0704-0188), Washington, DC 20503.				
1. AGENCY USE ONLY		2. REPORT DATE 30 September 1997	3. REPORT TYPE AND DATES COVERED Progress Report 5/97 to 9/97	
4. TITLE AND SUBTITLE Development of a Shell Element with Pressure Variation Through the Thickness			5. FUNDING NUMBERS  N00167-97-WR-70463	
6. AUTHOR(S) Young W. Kwon				
7. PERFORMING ORGANIZATION NAME(S) AND ADDRESS(ES) Naval Postgraduate School Monterey, CA 93943-5000			8. PERFORMING ORGANIZATION REPORT NUMBER NPS-ME-97-006	
9. SPONSORING/MONITORING AGENCY NAME(S) AND ADDRESS(ES) Naval Surface Warfare Center, Carderock Division West Bethesda, Maryland 20817-5700			10. SPONSORING/MONITORING AGENCY REPORT NUMBER	
11. SUPPLEMENTARY NOTES The views expressed in this report are those of the authors and do not reflect the official policy or position of the Department of Defense or the U.S. Government				
12a. DISTRIBUTION/AVAILABILITY STATEMENT Approved for public release; distribution is unlimited			12b. DISTRIBUTION CODE A	
13. ABSTRACT ( <i>Maximum 200 words</i> ) A shell formulation was developed from a three-dimensional solid. The shell element is an isoparametric element, and has four corner nodes at which there are three displacements and three rotations, independently. Therefore, the element formulation includes the transverse shear deformation and the transverse normal deformation. In addition, the formulation consists of separate components of the mean stress and deviatoric stresses because the Gurson constitutive model for void growth is based on the mean stress and the dilatation. As a result, the Gurson void model can be implemented in the shell formulation at the next stage. The shell element uses the reduced integration along the inplane axes and full integration along the transverse direction. If more accuracy is required along the thickness of the shell, a large number of integration points can be selected in the direction. Verification of the shell element was performed for a plate problem and a shell problem whose analytical solutions were available. The next phase of the work is to implement the Gurson model in the shell element. Once those are successfully completed, the module will be incorporated into the DYSMAS program				
14. SUBJECT TERMS Finite Element Method, Shell Formulation, High Order Element, Void Model			15. NUMBER OF PAGES 12	
			16. PRICE CODE	
17. SECURITY CLASSIFICATION OF REPORT Unclassified	18. SECURITY CLASSIFICATION OF THIS PAGE Unclassified	19. SECURITY CLASSIFICATION OF ABSTRACT Unclassified	20. LIMITATION OF ABSTRACT UN	

NSN 7540-01-280-5500

Standard Form 298 (Rev 2-89)  
Prescribed by ANSI Std Z39-18

HIGH QUALITY LITHOGRAPHY

## ABSTRACT

A shell formulation was developed from a three-dimensional solid. The shell element is an isoparametric element, and has four corner nodes at which there are three displacements and three rotations, independently. Therefore, the element formulation includes the transverse shear deformation and the transverse normal deformation. In addition, the formulation consists of separate components of the mean stress and deviatoric stresses because the Gurson constitutive model for void growth is based on the mean stress and the dilatation. As a result, the Gurson void model can be implemented in the shell formulation at the next stage. The shell element uses the reduced integration along the inplane axes and full integration along the transverse direction. If more accuracy is required along the thickness of the shell, a large number of integration points can be selected in the direction. Verification of the shell element was performed for a plate problem and a shell problem whose analytical solutions were available. The next phase of the work is to implement the Gurson model into the shell element. Once those are successfully completed, the module will be incorporated into the DYSMAS program.

## TABLE OF CONTENTS

1. INTRODUCTION .....	1
2. FINITE ELEMENT FORMULATION .....	2
3.1 Geometry .....	2
3.2 Displacement .....	2
3.3 Strain-Displacement Relation .....	4
3.4 Jacobian Matrix .....	4
3.5 Element Stiffness Matrix .....	5
3. EXPLICIT TIME INTEGRATION .....	8
4. VERIFICATION EXAMPLES .....	9
5. CONCLUSIONS .....	11
REFERENCES .....	12
INITIAL DISTRIBUTION LIST .....	13

## 1. INTRODUCTION

Computer simulation of ship shock trial is one of the goals in the U.S. Navy even if there are some limitations in the simulation because some phenomena cannot be represented by mathematical models. However, replacing physical testing by computer simulation as many as possible will reduce the costs in the design, production, and qualification processes.

As a result, a computer simulation program has been developed by the Naval Surface Warfare Center (NSWC) in collaboration with Germany. The program is expected to model both linear and nonlinear behaviors of ship structures under a shock loading. In other words, failure process needs to be modeled in a accurate and reliable way. One of the efforts to model such a nonlinear failure process is to implement the damage constitutive equations in the program such as Gurson's void model.

Because the major ship structure is a shell, shell elements are used for modeling. Further, as stated above, the shell element must include the damage constitutive equation like Gurson's void model. Therefore, the overall objective of this research is to develop a shell element which can include the damage constitutive equation.

The research consists of a couple of different phases. The first phase is to develop a shell element which can include Gurson's void model at the next phase. One of the requirements for the shell formulation is that the formulation should be able to represent the pressure (mean stress) and deviatoric stresses separately because Gurson's void model was based on the pressure component.

The second phase is to implement the void model into the shell formulation developed in the first phase. Finally, the last phase is to incorporate the whole module into the DYSMAS program. For each phase of work, extensive verifications of the developed shell element must be conducted. This report covers the work for the first phase.

## 2. FINITE ELEMENT FORMULATION

### 3.1 Geometry

A point in a shell structure can be expressed by a vector sum of two vectors. One vector is a position vector from the origin of the coordinate system to a point on the reference surface of the shell element, and the other vector lies from the end of the position vector to the point under consideration. The midsurface of the shell is usually taken as the reference surface, but it is not required in this formulation. The second vector described above is usually normal to the reference surface. Therefore, the position vector of a point in a shell can be expressed as

$$\mathbf{x}_i(\xi, \eta, \zeta) = \sum_{k=1}^n N^k(\xi, \eta) \mathbf{x}_i^k + \sum_{k=1}^n N^k(\xi, \eta) H^k(\zeta) V_{3i}^k \quad (i = 1, 2, 3) \quad (1)$$

where  $\mathbf{x}_i$  is the position vector of a generic point of a shell;  $\xi$ ,  $\eta$ , and  $\zeta$  are the natural coordinate axes;  $N^k(\xi, \eta)$  and  $H^k(\zeta)$  are two-dimensional and one-dimensional shape functions in the natural coordinate system, respectively;  $\mathbf{x}_i^k$  is the position vector of the node  $k$  in the reference surface;  $V_{3i}^k$  is the unit vector at the node  $k$ ; and  $n$  is the number of nodes per element. In the present formulation, a four-noded shell element is considered.

Further, the unit vector  $V_{3i}^k$  is defined as

$$V_{3i}^k = \frac{(\mathbf{x}_i^k)^{top} - (\mathbf{x}_i^k)^{bottom}}{\|(\mathbf{x}_i^k)^{top} - (\mathbf{x}_i^k)^{bottom}\|} \quad (2)$$

where *top* and *bottom* indicate the top and bottom surfaces of the shell, and  $\| \cdot \|$  denotes the Euclidean norm. The one-dimensional shape function  $H^k$  is expressed as

$$H^k(\zeta) = \left[ \frac{1}{4}(1 + \zeta)(1 - \bar{\zeta}) - \frac{1}{4}(1 - \zeta)(1 + \bar{\zeta}) \right] \|(\mathbf{x}_i^k)^{top} - (\mathbf{x}_i^k)^{bottom}\| \quad (3)$$

in which  $\bar{\zeta}$  indicates the location of the reference surface and varied from -1 to 1.  $\bar{\zeta}=0$  denotes the midsurface.

### 3.2 Displacement

The displacement field in a shell can be written as

$$u_i(\xi, \eta, \zeta) = \sum_{k=1}^n N^k(\xi, \eta) u_i^k + \sum_{k=1}^n N^k(\xi, \eta) H^k(\zeta) (-V_{2i}^k \theta_{1i}^k + V_{1i}^k \theta_{2i}^k + V_{3i}^k \theta_{3i}^k) \quad (i = 1, 2, 3) \quad (4)$$

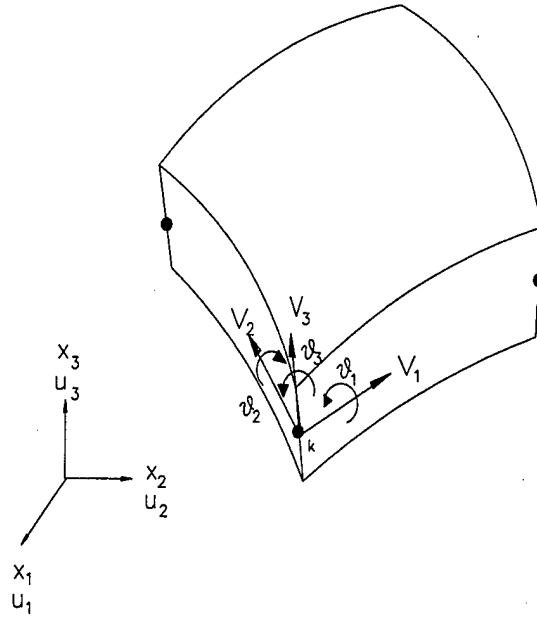

Figure 1. Shell Element

in which  $u_i$  is the displacement along the  $x_i$  axis,  $u_i^k$  is the nodal displacement at the node  $k$ , and unit vectors  $V_{1i}^k$  and  $V_{2i}^k$  lie along the reference surface.  $V_{1i}^k$ ,  $V_{2i}^k$ , and  $V_{3i}^k$  are perpendicular one another.  $\theta_{1i}^k$ ,  $\theta_{2i}^k$ , and  $\theta_{3i}^k$  are rotational degrees of freedom along the unit vectors  $V_{1i}^k$ ,  $V_{2i}^k$ , and  $V_{3i}^k$ , respectively. The right-hand rule is assumed for the positive direction of each rotation. That is, as the thumb of the right-hand is in the direction of each unit vector, the rotational direction of the hand is the positive rotation. (See Figure 1.)

$\theta_{1i}^k$  and  $\theta_{2i}^k$  are the bending rotations while  $\theta_{3i}^k$  is called the drilling rotational degree of freedom. To explain the role of  $\theta_{3i}^k$  in more detail, let us consider a flat plate whose plane is parallel to the  $x_1x_2$ -plane. Then, the displacement field in Eq. (4) can be rewritten as

$$u_i = u_i^{mid} + x_3\theta_i \quad (i = 1, 2, 3) \quad (5)$$

where  $u_1$  and  $u_2$  are the inplane displacements, and  $u_3$  is the transverse displacement. Superscript *mid* denotes the midplane of the plate. Equation (5) indicates that the transverse displacement is not constant through the plate thickness (i.e. along the  $x_3$ -axis). Therefore, in the present shell formulation, the transverse normal strain is included as well as the transverse shear strains.

### 3.3 Strain-Displacement Relation

Six strain components are computed from Eq. (4) by taking derivative with respect to the  $x_i$ -axis. The result can be written in matrix form like

$$\{\epsilon\} = [B]\{d\} \quad (6)$$

where

$$\{\epsilon\} = \{\epsilon_{11} \quad \epsilon_{22} \quad \epsilon_{33} \quad \gamma_{12} \quad \gamma_{23} \quad \gamma_{13}\}^T \quad (7)$$

$$[B] = [B^1 \quad B^2 \quad \dots \quad B^n] \quad (8)$$

and

$$\{d\} = \{d^1 \quad d^2 \quad \dots \quad d^n\}^T \quad (9)$$

The detailed expression for  $[B^k]$  is

$$[B^k] = \begin{bmatrix} \frac{\partial N^k}{\partial x_1} & 0 & 0 & -g_1^k V_{21}^k & g_1^k V_{11}^k & g_1^k V_{31}^k \\ 0 & \frac{\partial N^k}{\partial x_2} & 0 & -g_2^k V_{22}^k & g_2^k V_{12}^k & g_2^k V_{32}^k \\ 0 & 0 & \frac{\partial N^k}{\partial x_3} & -g_3^k V_{23}^k & g_3^k V_{13}^k & g_3^k V_{33}^k \\ \frac{\partial N^k}{\partial x_2} & \frac{\partial N^k}{\partial x_1} & 0 & -g_2^k V_{21}^k - g_1^k V_{22}^k & g_2^k V_{11}^k + g_1^k V_{12}^k & g_2^k V_{31}^k + g_1^k V_{32}^k \\ 0 & \frac{\partial N^k}{\partial x_3} & \frac{\partial N^k}{\partial x_2} & -g_k^k V_{22}^k - g_k^k V_{23}^k & g_k^k V_{12}^k + g_k^k V_{13}^k & g_k^k V_{32}^k + g_2^k V_{33}^k \\ \frac{\partial N^k}{\partial x_3} & 0 & \frac{\partial N^k}{\partial x_1} & -g_3^k V_{21}^k - g_1^k V_{23}^k & g_3^k V_{11}^k + g_1^k V_{13}^k & g_3^k V_{31}^k + g_1^k V_{33}^k \end{bmatrix} \quad (10)$$

in which

$$g_i^k = \frac{\partial N^k}{\partial x_i} H^k + N^k \frac{\partial H^k}{\partial x_i} \quad (11)$$

In addition, the vector  $\{d^k\}$  is

$$\{d^k\} = \{u_1 \quad u_2 \quad u_3 \quad \theta_1 \quad \theta_2 \quad \theta_3\} \quad (12)$$

### 3.4 Jacobian Matrix

In order to compute the derivatives such as  $\frac{\partial N^k}{\partial x_i}$  and  $\frac{\partial H^k}{\partial x_i}$ , it requires the Jacobian matrix defined as

$$[J] = \begin{bmatrix} x_{1,\xi} & x_{2,\xi} & x_{3,\xi} \\ x_{1,\eta} & x_{2,\eta} & x_{3,\eta} \\ x_{1,\zeta} & x_{2,\zeta} & x_{3,\zeta} \end{bmatrix} \quad (13)$$

where

$$\frac{\partial x_i}{\partial \xi} = \sum_{k=1}^n \frac{\partial N^k}{\partial \xi} x_i^k + \sum_{k=1}^n \frac{\partial N^k}{\partial \xi} H^k V_{3i}^k \quad (i = 1, 2, 3) \quad (14)$$

$$\frac{\partial x_i}{\partial \eta} = \sum_{k=1}^n \frac{\partial N^k}{\partial \eta} x_i^k + \sum_{k=1}^n \frac{\partial N^k}{\partial \eta} H^k V_{3i}^k \quad (i = 1, 2, 3) \quad (15)$$

$$\frac{\partial x_i}{\partial \zeta} = \sum_{k=1}^n N^k \frac{\partial H^k}{\partial \zeta} V_{3i}^k \quad (i = 1, 2, 3) \quad (16)$$

Inverse of the Jacobian matrix is called matrix  $[R]$ . Then,

$$\frac{\partial N^k}{\partial x_i} = R_{i1} \frac{\partial N^k}{\partial \xi} + R_{i2} \frac{\partial N^k}{\partial \eta} \quad (i = 1, 2, 3) \quad (17)$$

$$\frac{\partial H^k}{\partial x_i} = R_{i3} \frac{\partial H^k}{\partial \zeta} \quad (i = 1, 2, 3) \quad (18)$$

Here  $R_{ij}$  is the component of the matrix  $[R]$ .

### 3.5 Element Stiffness Matrix

Stresses and strains can be expressed as

$$\sigma_{ij} = -p\delta_{ij} + s_{ij} \quad (i, j = 1, 2, 3) \quad (19)$$

$$\epsilon_{ij} = \frac{1}{3}e\delta_{ij} + e_{ij} \quad (i, j = 1, 2, 3) \quad (20)$$

where  $p$  and  $s_{ij}$  are the hydrostatic pressure and the deviatoric stresses, and  $e$  and  $e_{ij}$  are the dilatation and the deviatoric strains.

The principle of virtual work states

$$\delta W - \delta U = 0 \quad (21)$$

where  $\delta W$  and  $\delta U$  are the virtual work of the external and internal loads, respectively. In more detail,

$$\delta U = \int_{\Omega} \sigma_{ij} \delta \epsilon_{ij} d\Omega \quad (22)$$

where  $\Omega$  indicates the shell volume.

Substitution of the stress and strain expressions, Eqs (19) and (20), into the virtual change in the strain energy, Eq. (22), yields

$$\delta U = \int_{\Omega} (-p\delta e + s_{ij}\delta e_{ij})d\Omega \quad (23)$$

For linear elastic materials, the following constitutive equations are assumed.

$$p = -Ke \quad (24)$$

$$s_{ij} = 2Ge_{ij} \quad (25)$$

where  $K$  is the bulk modulus and  $G$  is the shear modulus. Substitution of Eqs (24) and (25) into Eq. (23) results in

$$\delta U = \int_{\Omega} (K \epsilon \delta \epsilon + 2G e_{ij} \delta e_{ij}) d\Omega \quad (26)$$

Equation (26) is derived for a three-dimensional solid. For a shell, plane stress condition is assumed for the inplane stress components  $\sigma_{11}$ ,  $\sigma_{22}$ , and  $\sigma_{12}$ . With this implementation, Eq. (26) yields the element stiffness matrix for a four-noded shell as below:

$$[K^e] = \int_{\Omega^e} [B_p]^T [\bar{D}_p] [B_p] d\Omega + \int_{\Omega} [B]^T [\bar{D}] [B] d\Omega \quad (27)$$

where the first and second integrals are related to the volumetric and distortional strain energies, respectively. Matrix  $[B]$  was defined in Eq. (8) and its size is 6 by 24 for the four-noded shell element. Matrix  $[B_p]$  is the upper half submatrix of the matrix  $[B]$ , which contains the matrix components related to three normal strains. Thus, matrix  $[B_p]$  has the size of 3 by 24.

In addition, matrices  $[\bar{D}]$  and  $[\bar{D}_p]$  are computed from

$$[\bar{D}] = [T]^T [D] [T] \quad (28)$$

and

$$[\bar{D}_p] = [T_p]^T [D_p] [T_p] \quad (29)$$

in which the transformation matrix  $[T]$  is expressed as

$$[T] = \begin{bmatrix} l_{11}^2 & l_{12}^2 & l_{13}^2 & l_{11}l_{12} & l_{12}l_{13} & l_{13}l_{11} \\ l_{21}^2 & l_{22}^2 & l_{23}^2 & l_{21}l_{22} & l_{22}l_{23} & l_{23}l_{21} \\ l_{31}^2 & l_{32}^2 & l_{33}^2 & l_{31}l_{32} & l_{32}l_{33} & l_{33}l_{31} \\ 2l_{11}l_{21} & 2l_{12}l_{22} & 2l_{13}l_{23} & (l_{11}l_{22} + l_{21}l_{12}) & (l_{12}l_{23} + l_{22}l_{13}) & (l_{13}l_{21} + l_{23}l_{11}) \\ 2l_{21}l_{31} & 2l_{22}l_{32} & 2l_{23}l_{33} & (l_{21}l_{32} + l_{31}l_{22}) & (l_{22}l_{33} + l_{32}l_{23}) & (l_{23}l_{31} + l_{33}l_{21}) \\ 2l_{31}l_{11} & 2l_{32}l_{12} & 2l_{33}l_{13} & (l_{31}l_{12} + l_{11}l_{32}) & (l_{32}l_{13} + l_{12}l_{33}) & (l_{33}l_{11} + l_{13}l_{31}) \end{bmatrix} \quad (30)$$

and the matrix  $[T_p]$  is a 3 by 3 matrix consisting of the first three rows and columns of the matrix  $[T]$ . Here,  $l_{ij}$  is the direction cosines of the unit vector  $V_i$  with respect to the  $x_j$ -axis.

Matrix  $[D]$  for an isotropic elastic material is defined as

$$[D] = 2G \begin{bmatrix} \frac{(2Ga+2)}{3} & \frac{(2Ga-1)}{3} & -\frac{1}{3} & 0 & 0 & 0 \\ \frac{(2Ga-1)}{3} & \frac{(2Ga+2)}{3} & -\frac{1}{3} & 0 & 0 & 0 \\ -\frac{1}{3} & -\frac{1}{3} & \frac{2}{3} & 0 & 0 & 0 \\ 0 & 0 & 0 & \frac{1}{2} & 0 & 0 \\ 0 & 0 & 0 & 0 & \frac{1}{2}\kappa & 0 \\ 0 & 0 & 0 & 0 & 0 & \frac{1}{2}\kappa \end{bmatrix} \quad (31)$$

where

$$a = \frac{-\frac{1}{3} + \frac{K}{2G}}{\frac{2}{3} + \frac{K}{2G}} \quad (32)$$

and  $\kappa$  is the transverse shear correction factor. The other material property matrix  $[D_p]$  for an isotropic elastic material is

$$[D_p] = \begin{bmatrix} (1-a)K & (1-a)K & 1 \\ (1-a)K & (1-a)K & 1 \\ 1 & 1 & 1 \end{bmatrix} \quad (33)$$

### 3. EXPLICIT TIME INTEGRATION

For transient analysis of a shell using the explicit time integration technique, it is not necessary to form element stiffness matrices explicitly. Instead, element internal force vectors are computed and assembled. Then, the acceleration vector is computed from

$$\{\ddot{U}\}^t = [M]^{-1}(\{F_{ext}\}^t - \{F_{int}\}^t) \quad (34)$$

where  $\{\ddot{U}\}$  is the system acceleration vector,  $[M]$  is the system mass matrix,  $\{F_{ext}\}$  is the system external force vector,  $\{F_{int}\}$  is the system internal force vector, and superscript  $t$  denotes time at  $t$ . If the mass matrix is a diagonal matrix, the invers process becomes very simple and quick.

The system internal force vector is obtained from

$$\{F_{int}\}^t = \sum \{f\}^t \quad (35)$$

in which the summation is over the entire elements and  $\{f\}$  is an internal force vector for each element. The force vector is computed from

$$\int_{\Omega^e} [B_p]^T p \begin{Bmatrix} 1 \\ 1 \\ 1 \end{Bmatrix} d\omega + \int_{\Omega} [B_d]^T \{s\} d\Omega \quad (36)$$

where  $[B_p]$  is the matrix relating deviatoric strains to the nodal displacement/rotation vector, and  $\{s\}$  is the deviatoric stress vector.

When the constitutive equation for voids, such as the Gurson yield function, is included in the analysis, the pressure in the above equation can be computed from Eq. (12) in Ref. [1]. Because Ref. [1] has a detailed development of the Gurson model, it is not repeated here. In the next phase of research, the Gurson model will be implemented into the program.

#### 4. VERIFICATION EXAMPLES

Some example problems were solved to verify the present shell formulation. Static analysis was conducted for a plate and a shell. Static analysis checks the stiffness matrix formulation which is the essential part of the present shell element.

The first example was a clamped square plate with a concentrated force at the center of the plate. The plate dimension is 10 in. by 10 in. with the thickness of 0.1 in. The elastic modulus and Poisson's ratio are 10 msi and 0.2, respectively. The applied force is 40 lb. The analytical deflection at the center of the plate is  $2.45 \times 10^{-2}$  in. For the finite element modeling, a quarter of the plate was considered because of symmetry. Using four shell elements (2 elements x 2 elements) resulted in the center deflection of  $2.28 \times 10^{-2}$  in. which had a seven percent error compared to the analytical solution. On the other hand, use of 16 elements (4 elements x 4 elements) gave the deflection of  $2.43 \times 10^{-2}$  in. which had an error less than one percent. The plate was modeled to be in the xy-plane, yz-plane or xz-plane to check the transformation matrix. All cases gave the same deflection except that its direction was different depending on the orientation of the plate and the load.

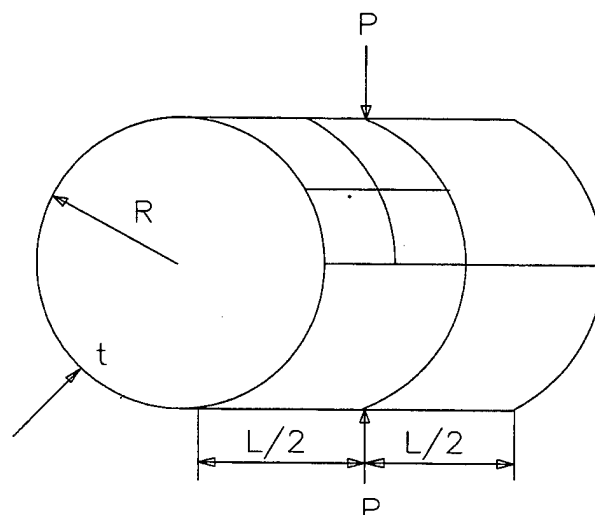

$$R=5.0\text{in. } t=0.094\text{in. } L=10.35\text{in.} \\ E=1.05e7\text{psi } \nu=0.3125$$

Figure 2. Pinched Shell With 2x2 Mesh Shown

The next problem was a pinched cylinder along a diameter as shown in Figure 2. Both ends of the cylinder were free. The cylinder had the radius of 5 in., the length of 10.35 in., and thickness of 0.094 in. The elastic modulus and Poisson's ratio were 10.5 msi and 0.3125, respectively. The pinched load was 100 lb. Because of symmetry, one eighth of the cylinder was modeled. The inextensional shell theory gave the radial contraction of 0.1117 in. However, the solution did not include the extensional deformation. As a result, the finite element solution including extensional deformation was expected to be higher than the solution. The present analysis showed that the four element model (2 elements x 2 elements) gave the displacement 0.0913 in. As the mesh was refined, the displacement was 0.1219 in. for the 100 element model (10 elements x 10 elements) and 0.1236 in. for the 256 element model (16 elements x 16 elements), respectively.

## 5. CONCLUSIONS

The present phase of this research was to formulate a shell element which could be used to model the void growth as a shell structure underwent nonlinear failure process caused by a shock loading. Gurson's model was chosen to simulate the void growth in a metallic material. The void model was based on the mean stress (or pressure). As a result, the shell element formulation was developed in terms of separate mean stress and deviatoric stress components so that the void model could be incorporated into the shell element. The developed shell element was verified using some analytical problems.

The next phase of the work is to further verify the formulation and to implement the void model into the shell element. Once this phase is completed successfully, the whole module will be implemented into the DYSMAS program.

## REFERENCES

- [1] Addressio, F. L., Joshson, J. N., and Maudlin, P. J., "The Effect of Void Growth on Taylor Cylinder Impact Experiments", *J. Appl. Phys.*, Vol. 73, No. 3, June 1983, pp. 7288-7297.

## INITIAL DISTRIBUTION LIST

	No. of Copies
1. Defense Technology Information Center Cameron Station Alexandria, Virginia 22304-6145	2
2. Library, Code 52 Naval Postgraduate School Monterey, California 93943	2
3. Professor Young W. Kwon, Code ME/Kw Naval Postgraduate School Monterey, California 93943	2
4. Mr. John McKirgan, Code 614 Naval Surface Warfare Center Carderock Division 9500 MacArthur Boulevard West Bethesda, Maryland 20817-5700	2
5. Mr. Ed Johnson Naval Surface Warfare Center Indian Head Division Code 40E, Bldg 302 Indian Head, Maryland 20640-5035	1
6. Research Office, Code 09	1