

**UNITED STATES AIR FORCE  
ARMSTRONG LABORATORY**

---

**Measurement of Sonic Booms and  
Aircraft Noise in the Gandy Range  
Extension**

**Kenneth J. Plotkin  
Carey L. Moulton  
Kenneth D. Frampton**

Wyle Research Laboratory  
2001 Jefferson Davis Highway  
Arlington Virginia 22202

19971121 096

August 1991

DTIC QUALITY INSPECTED 3

*Approved for public release;  
distribution is unlimited.*

**Occupational and Environmental Health  
Directorate  
Bioenvironmental Engineering Division  
Noise Effects Branch  
2610 Seventh Street  
Wright-Patterson AFB OH 45433-7901**

## NOTICES

When US Government drawings, specifications, or other data are used for any purpose other than a definitely related Government procurement operation, the Government thereby incurs no responsibility nor any obligation whatsoever, and the fact that the Government may have formulated, furnished, or in any way supplied the said drawings, specifications, or other data, is not to be regarded by implication or otherwise, as in any manner licensing the holder or any other person or corporation, or conveying any rights or permission to manufacture, use, or sell any patented invention that may in any way be related thereto.

Please do not request copies of this report from the Armstrong Laboratory. Additional copies may be purchased from:

National Technical Information Service  
5285 Port Royal Road  
Springfield, Virginia 22161

Federal Government agencies registered with the Defense Technical Information Center should direct requests for copies of this report to:

Defense Technical Information Center  
8725 John J. Kingman RD., STE 0944  
Ft Belvoir, VA 22060-6218

## DISCLAIMER

This Technical Report is published as received and has not been edited by the Technical Editing Staff of the Armstrong Laboratory.

## TECHNICAL REVIEW AND APPROVAL

AL/OE-TR-1997-0140

This report has been reviewed by the Office of Public Affairs (PA) and is releasable to the National Technical Information Service (NTIS). At NTIS, it will be available to the general public, including foreign nations.

This technical report has been reviewed and is approved for publication.



ROBERT A. LEE  
Chief, Noise Effects Branch

FOR THE DIRECTOR



LARRY T. KIMM, Major, USAF, BSC  
Chief, Bioenvironmental Engineering Division

REPORT DOCUMENTATION PAGE			Form Approved OMB No. 0704-0188	
Public reporting burden for this collection of information is estimated to average 1 hour per response, including the time for reviewing instructions, searching existing data sources, gathering and maintaining the data needed, and completing and reviewing the collection of information. Send comments regarding this burden estimate or any other aspect of this collection of information, including suggestions for reducing this burden, to Washington Headquarters Services, Directorate for Information Operations and Reports, 1215 Jefferson Davis Highway, Suite 1204, Arlington, VA 22202-4302, and to the Office of Management and Budget, Paperwork Reduction Project (0704-0188), Washington, DC 20503.				
1. AGENCY USE ONLY (Leave blank)	2. REPORT DATE August 1991	3. REPORT TYPE AND DATES COVERED Interim Aug 89 - Aug 91		
4. TITLE AND SUBTITLE  Measurement of Sonic Booms and Aircraft Noise in the Gandy Range Extension			5. FUNDING NUMBERS  PE - 62202F PR - 7757 TA - 7757C1 WU - 7757C101	
6. AUTHOR(S)  Kenneth J. Plotkin, Carey L. Moulton, Kenneth D. Frampton				
7. PERFORMING ORGANIZATION NAME(S) AND ADDRESS(ES)  Wyle Research Laboratory 2001 Jefferson Davis Highway Arlington Virginia 22202			8. PERFORMING ORGANIZATION  Wyle Research Laboratory	
9. SPONSORING/MONITORING AGENCY NAME(S) AND ADDRESS(ES)  Armstrong Laboratory, Occupational and Environmental Health Directorate Bioenvironmental Engineering Division Noise Effects Branch 2610 Seventh Street Wright-Patterson AFB OH 45433-7901			10. SPONSORING/MONITORING  AL/OE-TR-1997-0140	
11. SUPPLEMENTARY NOTES				
12a. DISTRIBUTION/AVAILABILITY STATEMENT  Approved for public release; distribution is unlimited.			12b. DISTRIBUTION CODE  A	
13. ABSTRACT (Maximum 200 words)  The Record of Decision allowing supersonic operations in the Gandy Range Extension specified studies of the effect of sonic booms on certain species in the Deep Creek Range. In support of those studies, sonic booms were monitored around the Deep Creek Range over a period of about eight months. Monitoring was conducted inside and outside the supersonic area. Because noise associated with subsonic aircraft operations was also of concern, the monitoring project included measurements of conventional noise.				
14. SUBJECT TERMS  Sonic Boom, Aircraft noise, Measurement			15. NUMBER OF PAGES 40	
			16. PRICE CODE	
17. SECURITY CLASSIFICATION OF REPORT UNCLASSIFIED	18. SECURITY CLASSIFICATION OF THIS PAGE UNCLASSIFIED	19. SECURITY CLASSIFICATION OF ABSTRACT UNCLASSIFIED	20. LIMITATION OF ABSTRACT UNLIMITED	

**This Page Intentionally  
Left Blank**

## TABLE OF CONTENTS

		<u>Page</u>
1.0	INTRODUCTION . . . . .	1
2.0	MONITORING PROCEDURES . . . . .	2
2.1	Properties of Sonic Boom and Noise . . . . .	2
2.1.1	Sonic Boom . . . . .	2
2.1.2	Subsonic Noise . . . . .	5
2.1.3	Cumulative Noise Impact . . . . .	6
2.2	Instrumentation . . . . .	9
2.2.1	Boom Event Analyzer Recorder (BEAR) Sonic Boom Monitor . . . . .	9
2.2.2	Larson-Davis Model 700 Noise Monitors . . . . .	11
2.3	Instrumentation Deployment and Operation . . . . .	11
3.0	ANALYSIS AND RESULTS . . . . .	18
3.1	Analysis Procedures . . . . .	18
3.2	Results . . . . .	18
	REFERENCES . . . . .	R1

## LIST OF FIGURES

<u>Fig. No.</u>		
1	Sonic Boom Waveform Generation . . . . .	3
2	Sonic Boom Overpressure From F-16, Level Flight at Mach 1.2 . . . . .	4
3	BEAR Monitor System . . . . .	10
4	Larson-Davis Model 700 . . . . .	12
5	Monitoring Sites . . . . .	13
6	Installed BEAR at Site 9 . . . . .	15
7	BEAR and LD-700 Microphones on Ground Plate . . . . .	16

DTIC QUALITY INSPECTED 8

**LIST OF TABLES**

<u>Table No.</u>		<u>Page</u>
1	Noise Levels From an F-16 at Low Altitude and High Speed . . . . .	7
2	Annoyance Due to Cumulative Exposure to Sonic Booms and Aircraft Noise . . . . .	8
3	Coordinates of Monitoring Sites . . . . .	14
4	Measured Sonic Boom and Noise Events, Site 0 . . . . .	20
5	Measured Sonic Boom and Noise Events, Site 1 . . . . .	21
6	Measured Sonic Boom and Noise Events, Site 2 . . . . .	22
7	Measured Sonic Boom and Noise Events, Site 3 . . . . .	23
8	Measured Sonic Boom and Noise Events, Site 4 . . . . .	24
9	Measured Sonic Boom and Noise Events, Site 5 . . . . .	25
10	Measured Sonic Boom and Noise Events, Site 6 . . . . .	26
11	Measured Sonic Boom and Noise Events, Site 7 . . . . .	27
12	Measured Sonic Boom and Noise Events, Site 8 . . . . .	28
13	Measured Sonic Boom and Noise Events, Site 9 . . . . .	29
14	Cumulative Noise Exposure . . . . .	30

## 1.0 INTRODUCTION

The Record of Decision allowing supersonic operations in the Gandy Range Extension<sup>1</sup> specified studies of the effect of sonic booms on certain species in the Deep Creek Range. In support of those studies, sonic booms were monitored around the Deep Creek Range over a period of about eight months. Monitoring was conducted inside and outside the supersonic area. Because noise associated with subsonic aircraft operations was also of concern, the monitoring project included measurements of conventional noise.

Section 2.0 of this report contains a description of the monitoring project and the instrumentation used. A discussion of the nature of sonic booms and subsonic noise is included. The results of the monitoring project are presented in Section 3.0.

## 2.0 MONITORING PROCEDURES

### 2.1 Properties of Sonic Boom and Noise

#### 2.1.1 Sonic Boom

When an aircraft exceeds the speed of sound, its disturbance to the air is in the form of shock waves which are heard as a sonic boom. Figure 1 illustrates the generation of a sonic boom and its propagation to the ground. Near the aircraft, there is a complex pattern, very closely related to the geometry of the aircraft. As the boom propagates away from the aircraft, it tends to distort into a much simpler shape: the N-wave seen at the bottom of Figure 1. This consists of two shock waves of approximately equal strength, joined by a linear expansion. For fighter aircraft, the two shock waves are separated by 100 to 200 milliseconds, and one generally hears a double bang. The amplitude of the shocks (peak overpressure) depends primarily on aircraft flight altitude, size and weight, and aircraft maneuvers. It varies only slightly with Mach number. Figure 2 shows the peak overpressure, as a function of flight altitude above the ground, for an F-16 in steady level flight at Mach 1.2.

The N-wave shown in Figure 1 is the time history of pressure: it is what would be recorded if a microphone were connected to an oscilloscope. The time history (often referred to as the "signature") is usually an N-wave. Different signatures can occur. Maneuvering aircraft can generate, in limited areas, amplified "focus booms" which have a peaked "U-wave" shape. Other signature shapes occur under different conditions, the most common variation being N-waves which have been distorted by atmospheric turbulence.

When measuring sonic booms, it is typical to directly record the signature. Having the full signature available for examination allows discrimination between sonic booms and other impulsive sounds which may occur. Assessment of potential impact from individual sonic booms is based on two noise descriptors which are derived from the signature. These are:

- Peak overpressure - the amplitude, in pounds per square foot (psf), of the leading shock wave. Peak sound pressures may also be expressed in decibels, by the relation  $L_{pk} = 127.6 + 10 \log_{10} p$ , where  $p$  is the overpressure in psf.

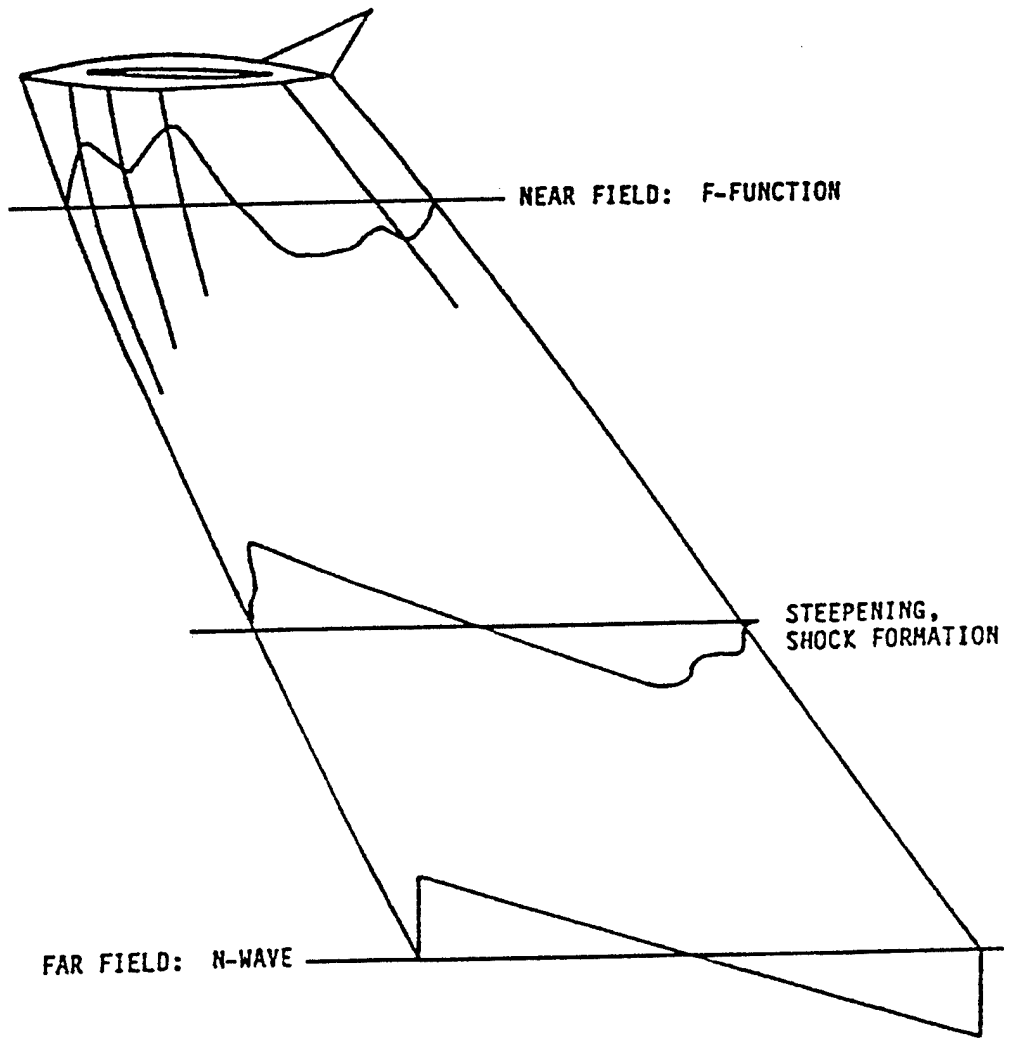

Figure 1. Sonic Boom Waveform Generation.

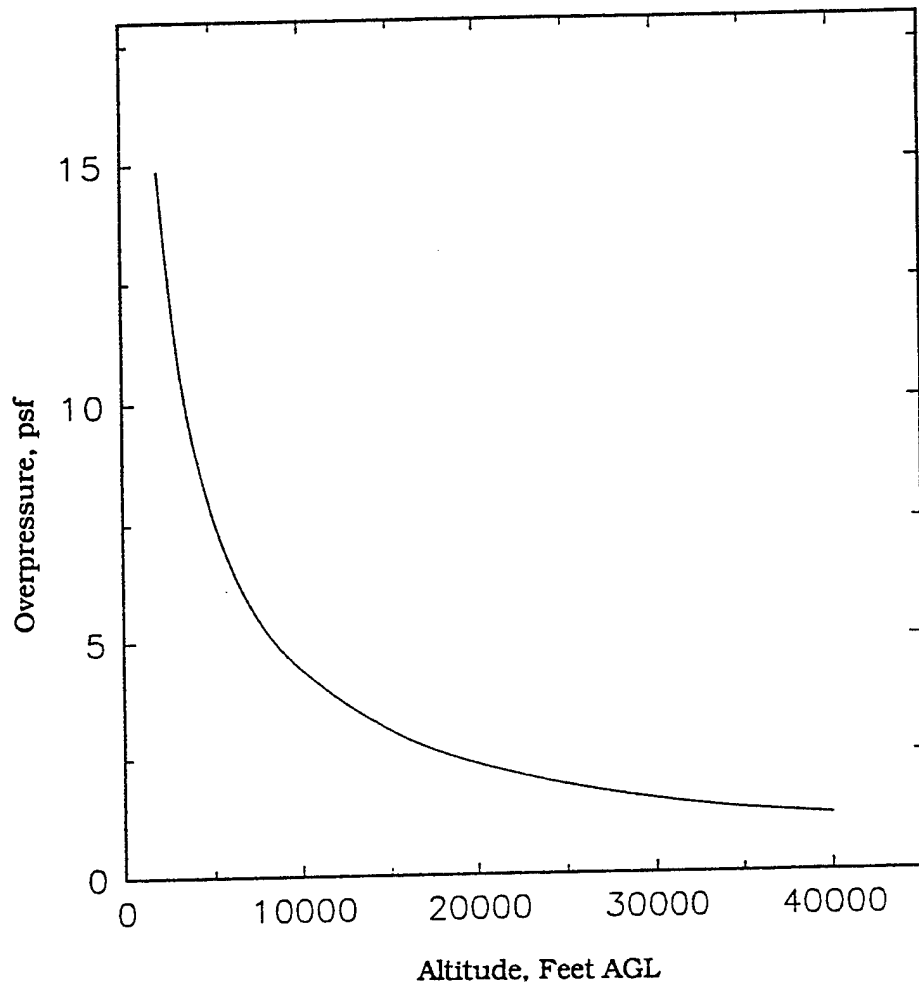

Figure 2. Sonic Boom Overpressure From F-16, Level Flight at Mach 1.2.

- C-weighted sound exposure level (CSEL) – a measure of the total sound energy within the frequency range of human hearing, expressed in decibels.

The peak overpressure can be picked directly off a signature plot. Calculation of CSEL is more complex, and requires the following steps:

1. The original signal is passed through a filter corresponding to C-weighting.<sup>2</sup> This filter is flat over the range of human hearing, approximately 20 Hz to 20 kHz, and falls off sharply above and below this range.
2. The filtered signal is squared, then integrated to obtain a quantity proportional to the total acoustic energy.
3. The energy is normalized to a standard reference, then logged and multiplied by ten. This result is CSEL, in decibels.

These three steps can be handled electronically, by the circuitry in an integrating sound level meter, or can be computed from a digitized signature.

### 2.1.2 Subsonic Noise

The noise associated with flight at subsonic speeds is due to the engine(s) and turbulent flow around the aircraft. Unlike sonic booms, which are coherent impulses, subsonic noise is incoherent and continuous in nature. Even though noise from a high-speed, low-altitude flyover may vary significantly over a few seconds, it is meaningful to consider averages over periods of a second or less.

The potential impact of subsonic noise is quantified by the frequency content of the noise, its average amplitude, and its duration. The exact time signature, important for coherent impulses such as sonic booms, is not important. The descriptors of subsonic noise involve the following:

- Filtering by A-weighting<sup>2</sup> – This is a filter shape which approximates the frequency response of human hearing. Sounds which have different overall amplitudes and different frequency content will sound equally loud if their A-weighted levels are the same.

- Averaging over a short time period – typically either one second ("slow" response) or 1/8 second ("fast" response). This quantifies how loud the sound is at a given time. The amplitude is quantified on the logarithmic decibel scale.
- A measure of the duration of the sound – The most widely used method for accounting for the duration of sound is the sound exposure level (SEL), which represents (on the decibel scale) the total acoustic energy contained in the noise event. SEL accounts for the average level of the sound over the event time period (typically, the period during which it is either audible or above some threshold) and the total duration of the sound.

A-weighting and fast or slow averaging are standard functions of sound level meters. A sound level meter, at a minimum, consists of a microphone, a filter network (several, including A, are typically available), an rms detector which can be set to either fast or slow response, and a meter which displays the level in decibels. CSEL can be computed from levels which are read at regular intervals. Some sound level meters (referred to as integrating sound level meters) can record SEL directly.

The subsonic operations of interest here are fighter aircraft at high speeds and low altitudes. Table 1 shows typical maximum levels and SELs for an F-16 at 500 knots and various positions relative to a receiver on the ground. The values shown in Table 1 were derived from the Air Force's OMEGA10 software and NOISEFILE data base.<sup>3</sup> Sound levels are near the maximum for only a few seconds. The duration over which the aircraft noise is clearly noticeable (above 65 to 70 dB) in an otherwise quiet environment is typically 20 to 30 seconds.

### 2.1.3 Cumulative Noise Impact

The long-term adverse effects of noise over some time period are quantified by the day-night average level,  $L_{dn}$  (C-weighted  $L_{dn}$ ,  $L_{Cdn}$ , for sonic booms). This average is obtained by combining SEL (or CSEL) values from all events, on an energy basis, normalizing by the total period of time, then expressing in decibels. Because noise at night tends to be more intrusive than during the day, a 10 dB penalty is added to events after 2200 and before 0700. Table 2 shows the

Table 1

Noise Levels From an F-16 at  
Low Altitude and High Speed

(a) 500 Feet AGL, Various Sideline Distances

Sideline Distance, Feet	$L_{max}$	SEL
0	102.9	102.2
500	99.3	99.6
1,000	94.0	95.5
2,000	86.1	89.1

(b) Under Track, Various Altitudes

Altitude, Feet AGL	$L_{max}$	SEL
500	102.9	102.2
1,000	95.5	96.7
5,000	74.4	79.7
10,000	61.9	69.1

Table 2

Annoyance Due to Cumulative Exposure  
to Sonic Booms<sup>5</sup> and Aircraft Noise<sup>4</sup>

$L_{Cdn}$	Percent Highly Annoyed	$L_{dn}$
45	1	47
46	2	48
47	2	49
48	2	50
49	3	51
50	3	52
51	3	54
52	4	55
53	4	56
54	5	57
55	6	58
56	7	59
57	8	60
58	9	62
59	10	63
60	12	64
61	14	65
62	16	66
63	18	67
64	20	69
65	23	70
66	25	71
67	28	72
68	32	73
69	35	74
70	39	76
71	42	77
72	46	78
73	50	79
74	54	80
75	58	81

percentage of population which can be expected to become highly annoyed when exposed to various values of  $L_{dn}$ <sup>4</sup> or  $L_{Cdn}$ .<sup>5</sup> The threshold of significant adverse impact is generally considered to occur at  $L_{dn}$  65 dB or  $L_{Cdn}$  61 dB.

## 2.2 Instrumentation

### 2.2.1 Boom Event Analyzer Recorder (BEAR) Sonic Boom Monitor

The BEAR is an instrument developed by the U.S. Air Force for the specific purpose of recording sonic boom signatures.<sup>6</sup> It is a digital microprocessor-controlled recording system, and operates automatically. It incorporates pattern recognition software so that it will record only those events which are likely to be sonic booms.

Figure 3 is a sketch of the system. The microphone (PCB 106B50) is mounted on a steel ground plate, within a hemispherical inner windscreen. A conical, fabric-covered, outer windscreen covers this. Sound impinging on the microphone system enters the BEAR, where it is digitized. A computer within the BEAR observes the incoming signal. When the signal exceeds a programmed threshold (just under 0.1 psf), the system examines various properties of the signal to determine if it is a candidate boom. If the signal satisfies the criteria, it is saved from the threshold point until it falls below a lower "off" threshold. The system can store about 40 seconds of data, which is adequate for over 100 sonic booms of 200 milliseconds duration each. With a full complement of batteries, a BEAR can operate unattended for up to six days, but it is prudent to service them every three to four days.

The recorded booms are stored in removable memory (RAM) modules. When the BEAR is serviced, the RAMs are removed and replaced with fresh ones. The data from the RAMs are transferred to a personal computer, where data are subsequently analyzed. The first step of analysis is to print out all signatures and examine them to determine which are booms. The discrimination criteria programmed into the BEAR are somewhat liberal so that, while excluding most non-boom events, there will be some records which are not booms. The booms are readily identified by visual examination.

# BOOM EVENT ANALYZER RECORDER (BEAR)

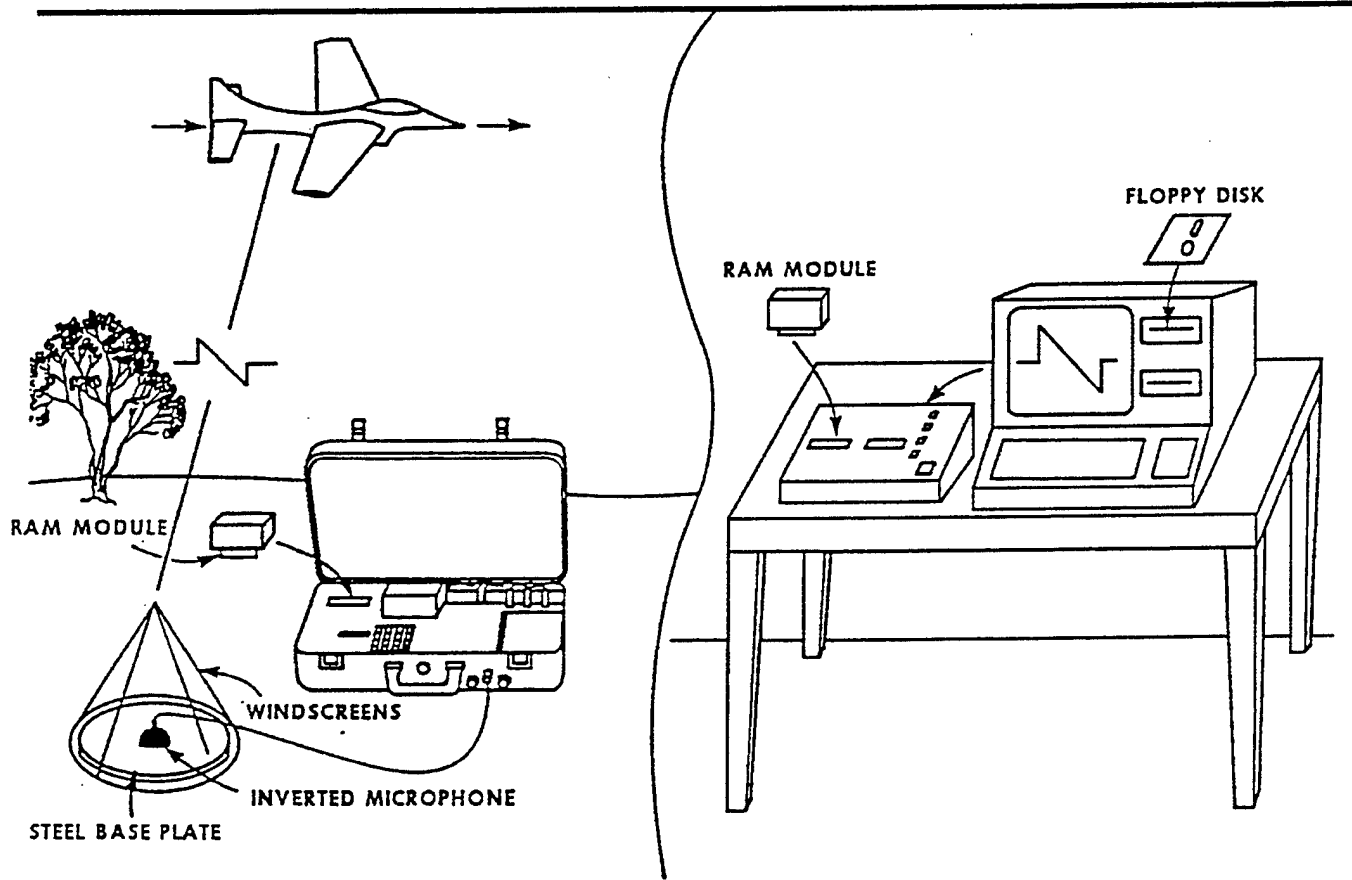

Figure 3. BEAR Monitor System.

### 2.2.2 Larson-Davis Model 700 Noise Monitors

The Larson-Davis Model 700 Dosimeter (LD-700) is a programmable digital integrating sound level meter. It can automatically record a variety of noise data, including the types described in Section 2.1.2, above. Figure 4 shows an LD-700 inside a weatherproof case, which also contains a battery which will sustain it for about two weeks. Not shown is the microphone, which was a GenRad Type 1971-9605 equipped with a PCB Type 402M76 preamplifier. For the current project, the LD-700s were programmed to record slow A-weighted sound levels and operate in "exceedance" mode. In this mode, whenever the level exceeded a threshold of 65 dB, the following data were recorded:

- The time at which the exceedance occurred;
- The duration, in seconds, above 65 dB;
- SEL during the exceedance;
- Maximum level during the exceedance.

The LD-700 can store up to 389 exceedances in its memory. Because the instrument does not discriminate sounds (all events above threshold are stored), the memory can contain substantial false data. When serviced, the instrument is connected to a portable computer, and the recorded data are transferred for subsequent analysis.

### 2.3 **Instrumentation Deployment and Operation**

The objective of this project was to monitor noise and sonic boom around the Deep Creek Range. Ten sites were selected. Figure 5 shows the locations on a map of the area. Table 3 lists the coordinates. Sites 1 through 9 circled the Deep Creeks. Site 0 was at the town of Gold Hill, which served as a base of operations and was also the site of some of the animal studies.

A BEAR and an LD-700 were deployed at each site. Figure 6 shows an installed BEAR at site 9. The BEAR microphone was arranged as sketched in Figure 3. The LD-700 microphone was fitted with a standard foam windscreen and placed on the BEAR's microphone ground plate. The conical windscreen then covered both microphones. Figure 7 shows a typical arrangement. On initial

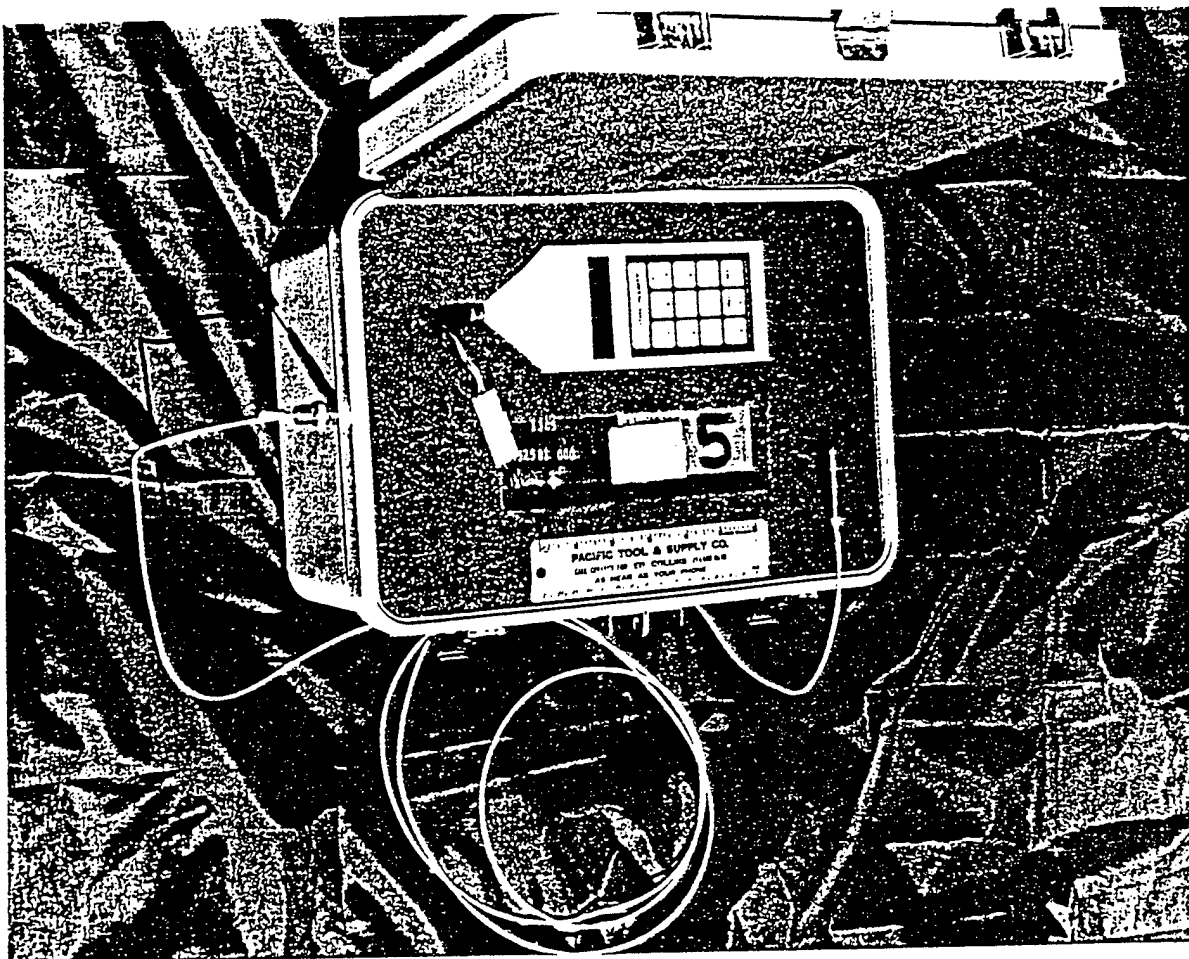

Figure 4. Larson-Davis Model 700.



Table 3  
Coordinates of Monitoring Sites

Site	Location	W. Longitude	N. Latitude
0	Gold Hill	113° 49.8'	40° 10.2'
1*	Elephant Knoll	114° 02.1'	40° 20.1'
2	N of 6 Mile Ranch	113° 43.7'	40° 01.8'
3	SW of Callao	114° 45.5'	39° 52.7'
4	Trout Creek Canyon Road	113° 48.5'	39° 44.5'
5	Pleasant Valley	114° 01.8'	39° 39.0'
6	S of Goshute Reservation	114° 12.9'	39° 51.2'
7	S of Ibapah	113° 59.0'	39° 55.7'
8	Pony Express	113° 56.8'	40° 05.7'
9	Center of SS Extension	114° 02.1'	40° 20.1'

\* BEAR only.

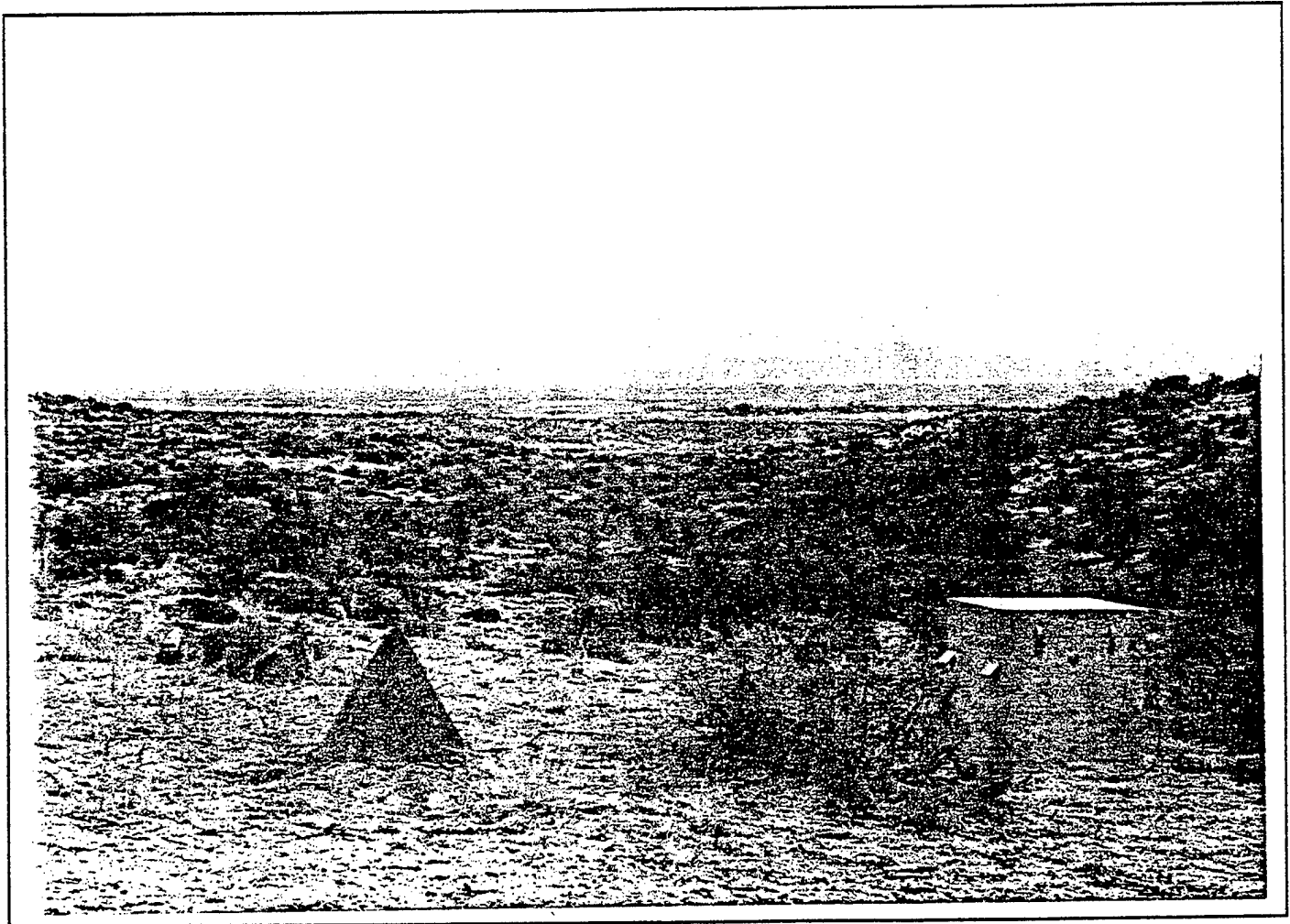

Figure 6. Installed BEAR at Site 9.

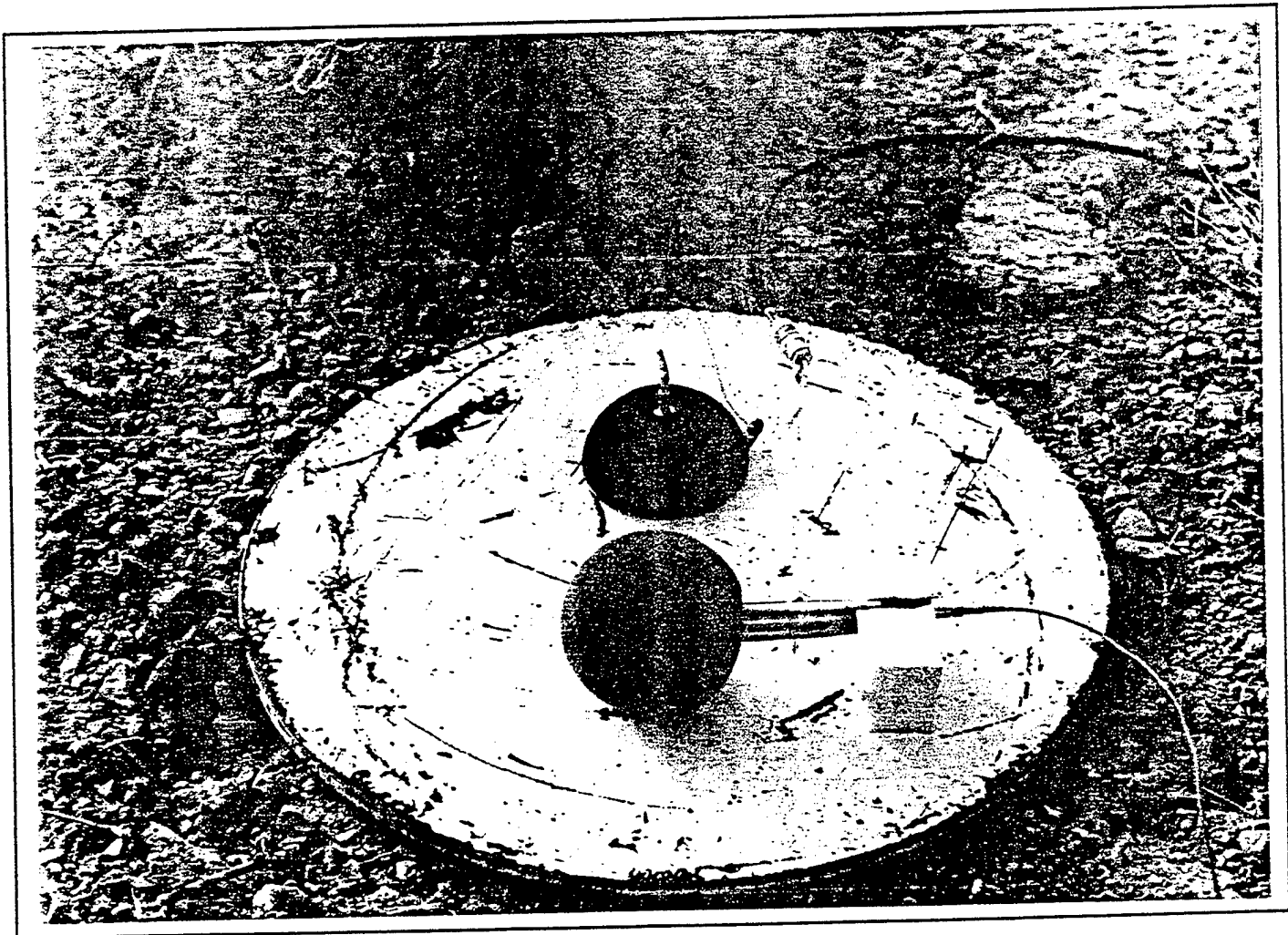

Figure 7. BEAR (rear) and LD-700 (front) Microphones on Ground Plate.

installation, and on all subsequent service visits, each instrument was field calibrated using a B&K Type 4220 pistonphone.

The systems were installed during 26 February through 2 March 1990. Installation was conducted by Wyle Laboratories and Utah State University, with Wyle training USU personnel in the operation of the instruments. The systems remained deployed through the end of October 1990. During this period, each site operated for about five months; specific statistics are presented later.

During the monitoring period, all field servicing of the instruments was conducted by USU. Each site visit yielded a data file for the LD-700 and a set of data files for the events recorded by the BEAR. These were forwarded to Wyle for interpretation and analysis. Field service logs were also forwarded. Section 3 of this report describes the analysis and results.

### 3.0 ANALYSIS AND RESULTS

#### 3.1 Analysis Procedures

Upon receiving BEAR and LD-700 data, and supporting field logs, the following was done:

- Each recorded BEAR signature was printed out and examined to determine whether it was a sonic boom. Those determined to be booms were retained, and the associated data files were consolidated.
- The consolidated BEAR data files were processed by program BOOMBEAR,<sup>7</sup> which picked off the peak pressure (expressed both in psf and as a decibel level) and computed CSEL.
- The data file from each LD-700 was printed out. Each exceedance was reviewed to see if it matched the pattern discussed in Section 2.1.2. For purposes of this project, a minimum level of 80 dB was considered. Each such exceedance was copied into a list for each site.
- The field service logs were reviewed, and the number of days during which each site was collecting data was determined. (Downtime was due to a variety of factors, including equipment failure, memory filling with false data due to storms, etc.)
- The CSELS and SELs at each site were each combined and normalized to obtain  $L_{Cdn}$  and  $L_{dn}$ .

#### 3.2 Results

The results of the measurements are shown in Tables 4 through 13. Shown in part (a) of each table is the following sonic boom data:

- The date and time of each boom.
- The amplitude of the boom: peak pressure, peak level, and CSEL.
- The operation time (days) for the BEAR at that site, and  $L_{Cdn}$ .

Part (b) of each table shows the following subsonic noise data:

- The date and time of the exceedance.
- The duration (seconds), SEL, and maximum level of the event.
- The operation time (days) for the LD-700 at that site, and  $L_{dn}$ .

The sonic boom events shown in Tables 4 through 13 are unquestionably sonic booms; the nature of the full-signature data collected by the BEARs allows positive identification. The LD-700 data does not allow for positive identification; many non-aircraft sounds (including large highway vehicles) have similar characteristics. The subsonic noise data shown in Tables 4 through 13 therefore includes all low-altitude flyovers near the sites, but includes other non-aircraft noise events as well.

Table 14 is a summary of the cumulative noise exposure at each site, showing the number of events, the number per day, and  $L_{Cdn}$  and  $L_{dn}$ . The following conclusions may be reached:

- Subsonic noise events, as recorded by the LD-700 systems, were insignificant.
- Sites 0, 1, 2, and 9, which are within the supersonic area, experienced more sonic booms than the other sites, outside the area. About one boom per week was recorded at each site.
- Sites outside the supersonic area experienced occasional booms – about one per month or less.
- $L_{Cdn}$  due to sonic booms was substantially below the threshold of 61 dB at which significant adverse impact would occur.  $L_{Cdn}$  diminished with increasing distance from the supersonic area.

The overall pattern is what might reasonably be expected – the greatest sonic boom activity is in the supersonic area, but there are occasional booms elsewhere. The overall numbers and magnitude of booms, as quantified by  $L_{Cdn}$ , are well below the threshold of significant impact.

Table 4

Measured Sonic Boom and Noise Events, Site 0

(a) BEAR Monitor Data (Sonic Booms)

Date	Time	$P_{max}$ (psf)	$L_{pk}$ (dB)	CSEL (dB)
3/15	1511	0.2952	117.0	90.0
3/15	1511	2.9942	137.1	100.5
3/15	1518	0.7357	124.9	97.5
3/30	1108	0.4170	120.0	95.2
3/30	1533	0.4756	121.1	95.5
3/30	1534	0.5763	122.8	97.2
4/19	1053	0.5553	122.5	96.5
8/29	1235	1.5135	131.2	105.4
8/29	1256	0.7685	125.3	102.6
9/20	2014	0.4686	121.0	97.7
9/20	2015	0.8013	125.7	100.9
9/24	1149	2.0852	134.0	109.8
9/24	1642	0.2155	114.3	85.6
10/9	1017	0.9653	127.3	101.7
10/9	1017	0.3303	118.0	95.6
10/30	2005	1.7103	132.3	107.7

Operation Time = 121 Days

$L_{Cdn} = 44.3$  dB

(b) Larson-Davis Data (Subsonic Noise)

Date	Time	Duration	SEL	$L_{max}$
4/7	19:06:02	0:10	84.5	101.0
4/12	15:46:56	0:26	93.5	85.0
4/12	15:53:24	0:20	91.0	84.5

Operation Time = 31 Days

$L_{Cdn} = 31.5$  dB

Table 5

Measured Sonic Boom and Noise Events, Site 1

(a) BEAR Monitor Data (Sonic Booms)

Date	Time	$P_{max}$ (psf)	$L_{pk}$ (dB)	CSEL (dB)
3/12	1113	0.2624	116.0	87.3
3/14	1350	0.4733	121.1	87.2
3/15	1254	1.1480	128.8	103.4
4/17	1253	1.0613	128.1	107.0
4/21	1007	0.5763	122.8	97.6
6/15	0913	0.9090	126.8	102.4
6/15	1034	0.6630	124.0	97.9
8/30	1438	0.2062	113.9	90.1
8/31	0959	0.7099	124.6	98.6
9/3	1454	0.1125	108.6	87.5
9/5	1821	1.0285	127.8	101.8
9/7	1017	0.8762	126.5	100.9
9/8	1021	0.7333	124.9	99.3
9/8	1022	0.4943	121.5	101.9
9/10	1745	0.3585	118.7	91.0
9/18	1646	5.5667	142.5	117.7
9/20	2014	0.1898	113.2	88.4
10/1	0850	0.2975	117.1	85.0

Operation Time = 89 Days

$L_{Cdn} = 49.9$  dB

No Larson-Davis Monitor at Site 1

Table 6

## Measured Sonic Boom and Noise Events, Site 2

## (a) BEAR Monitor Data (Sonic Booms)

Date	Time	P <sub>max</sub> (psf)	L <sub>pk</sub> (dB)	CSEL (dB)
3/13	1522	0.1804	112.7	89.6
3/13	1522	0.2038	113.8	94.6
3/13	1523	0.4451	120.6	96.5
6/11	1021	7.7245	145.4	112.7
6/14	1258	0.5951	123.1	90.3
6/14	1317	2.4038	135.2	102.9
9/3	1526	3.9642	139.6	112.1
9/18	1946	0.3983	119.6	94.8
9/26	1439	0.9957	127.6	101.0
10/4	1459	0.8247	125.9	99.1
10/9	1018	0.3116	117.5	94.6
10/9	1018	0.2975	117.1	92.4

Operation Time = 112 Days

L<sub>Cdn</sub> = 46.3 dB

## (b) Larson-Davis Data (Subsonic Noise)

Date	Time	Duration	SEL	L <sub>max</sub>
3/14	10:12:52	0:13	87.5	80.5
3/21	15:15:53	0:13	90.5	84.5
3/24	15:08:12	0:23	98.5	95.5
3/26	15:33:27	0:13	88.5	83.5
3/26	15:38:32	0:16	85.0	80.0
3/27	15:41:07	0:19	90.5	83.0
3/28	12:50:27	0:23	96.0	88.5
3/29	13:01:15	0:21	94.5	90.5
3/29	16:11:01	0:18	93.5	88.0
3/30	15:51:32	0:16	94.0	87.5
3/30	16:03:42	0:09	93.5	90.5
6/14	13:16:15	0:06	83.0	81.5
9/10	9:20:47	0:06	84.0	81.0
9/11	8:39:21	0:06	83.0	80.0
9/11	9:13:14	0:07	88.5	86.5
9/14	9:28:05	0:06	83.5	80.0
9/17	12:35:02	0:20	87.5	80.0
9/18	12:47:41	0:06	83.5	81.0
10/19	10:33:45	0:09	85.5	81.1

Operation Time = 151 Days

L<sub>Cdn</sub> = 32.8 dB

Table 7

Measured Sonic Boom and Noise Events, Site 3

(a) BEAR Monitor Data (Sonic Booms)

Date	Time	$P_{max}$ (psf)	$L_{pk}$ (dB)	CSEL (dB)
3/19	1105	0.2601	115.9	86.9
4/3	0849	1.1832	129.1	103.1
4/12	1504	2.0008	133.6	109.8
6/12	0914	1.4526	130.8	107.5
8/29	1255	1.3448	130.2	104.0

Operation Time = 130 Days

$$L_{Cdn} = 42.4 \text{ dB}$$

(b) Larson-Davis Data (Subsonic Noise)

Date	Time	Duration	SEL	$L_{max}$
3/21	15:16:35	0:18	95.5	90.0
3/21	15:32:26	0:15	89.0	83.0
3/29	18:46:15	0:19	86.0	80.0
8/29	12:55:08	0:05	83.0	82.5
9/25	16:42:19	0:18	89.0	86.0
10/4	12:29:27	0:22	98.0	93.5

Operation Time = 97 Days

$$L_{Cdn} = 31.6 \text{ dB}$$

Table 8

Measured Sonic Boom and Noise Events, Site 4

(a) BEAR Monitor Data (Sonic Booms)

Date	Time	P <sub>max</sub> (psf)	L <sub>pk</sub> (dB)	CSEL (dB)
4/12	1356	0.9325	127.0	103.5
4/12	1356	0.2975	117.1	93.2
4/12	1405	0.7942	125.6	99.5
4/15	1253	0.3116	117.5	86.7
9/20	2005	0.8411	126.1	103.0

Operation Time = 153 Days

L<sub>Cdn</sub> = 36.1 dB

(b) Larson-Davis Data (Subsonic Noise)

Date	Time	Duration	SEL	L <sub>max</sub>
3/15	14:16:49	0:14	107.5	104.5
3/21	15:33:34	0:20	87.0	80.5
3/21	16:18:28	0:18	94.0	90.5
3/21	16:36:11	0:16	92.5	96.5
10/18	10:20:58	0:08	85.0	82.0

Operation Time = 190 Days

L<sub>Cdn</sub> = 35.7 dB

Table 9

Measured Sonic Boom and Noise Events, Site 5

(a) BEAR Monitor Data (Sonic Booms)

Date	Time	$P_{max}$ (psf)	$L_{pk}$ (dB)	CSEL (dB)
3/30	1254	1.9493	133.4	106.7
8/28	1054	1.0707	128.2	103.6

Operation Time = 153 Days

$$L_{Cdn} = 36.1 \text{ dB}$$

(b) Larson-Davis Data (Subsonic Noise)

Date	Time	Duration	SEL	$L_{max}$
3/14	10:59:44	0:09	86.0	82.0
3/15	14:16:02	0:22	93.5	88.5
3/24	11:00:52	0:28	99.0	92.5
3/27	17:33:37	0:17	92.5	88.5

Operation Time = 182 Days

$$L_{Cdn} = 28.9 \text{ dB}$$

Table 10

Measured Sonic Boom and Noise Events, Site 6

(a) BEAR Monitor Data (Sonic Booms)

Date	Time	$P_{max}$ (psf)	$L_{pk}$ (dB)	CSEL (dB)
NO BOOMS RECORDED				

Operation Time = 116 Days

$L_{Cdn} = 0.0$  dB

(b) Larson-Davis Data (Subsonic Noise)

Date	Time	Duration	SEL	$L_{max}$
9/3	13:52:58	0:12	88.5	84.0
10/15	14:55:28	0:24	93.0	86.5

Operation Time = 131 Days

$L_{Cdn} = 23.8$  dB

Table 11

Measured Sonic Boom and Noise Events, Site 7

(a) BEAR Monitor Data (Sonic Booms)

Date	Time	$P_{max}$ (psf)	$L_{pk}$ (dB)	CSEL (dB)
3/13	1523	1.2160	129.3	104.6
3/19	1024	0.2858	116.7	88.2
4/20	0909	1.0613	128.1	102.3
10/4	1508	0.9559	127.2	103.5
10/17	1038	1.7876	132.6	105.5

Operation Time = 136 Days

$L_{Cdn} = 39.5$  dB

(b) Larson-Davis Data (Subsonic Noise)

Date	Time	Duration	SEL	$L_{max}$
9/22	19:08:09	0:15	85.0	80.0

Operation Time = 185 Days

$L_{Cdn} = 13.0$  dB

Table 12

Measured Sonic Boom and Noise Events, Site 8

(a) BEAR Monitor Data (Sonic Booms)

Date	Time	P <sub>max</sub> (psf)	L <sub>pk</sub> (dB)	CSEL (dB)
3/13	1522	1.3964	130.5	107.4
3/13	1528	0.3678	118.9	96.8
3/15	1255	0.2015	113.7	88.8
3/15	1511	0.2765	116.4	95.0
3/19	0024	2.2070	134.5	110.2
3/19	0025	1.2488	129.5	105.5

Operation Time = 128 Days

L<sub>Cdn</sub> = 50.9 dB (note the nighttime penalty events)

(b) Larson-Davis Data (Subsonic Noise)

Date	Time	Duration	SEL	L <sub>max</sub>
3/19	10:18:09	0:11	99.5	96.0
3/19	10:25:48	0:12	84.5	83.0
3/22	9:16:37	0:09	93.5	92.0
4/5	9:48:24	0:23	88.0	83.0
4/5	9:49:06	0:37	96.0	88.0
11/1	11:26:22	0:14	88.0	83.5
11/1	11:27:00	0:18	93.0	88.0
11/1	11:27:26	0:28	91.0	93.5
11/1	12:18:31	0:22	87.5	81.0
11/6	11:52:01	0:26	97.5	90.0

Operation Time = 85 Days

L<sub>Cdn</sub> = 35.5 dB

Table 13

Measured Sonic Boom and Noise Events, Site 9

(a) BEAR Monitor Data (Sonic Booms)

Date	Time	P <sub>max</sub> (psf)	L <sub>pk</sub> (dB)	CSEL (dB)
3/15	1253	0.8856	126.5	103.2
3/15	1254	0.8833	126.5	103.2
3/28	1413	0.4662	121.0	94.7
3/29	1014	0.9090	126.8	101.1
3/29	1014	0.4287	120.2	94.2
3/30	1534	0.5084	121.7	98.0
3/30	1534	0.2179	114.4	89.7
4/17	1253	0.3585	118.7	95.8
6/15	1016	0.1804	112.7	87.1
9/7	1019	0.2788	116.5	88.3
9/8	1031	3.4979	138.5	114.5
9/8	1031	2.5772	135.8	109.3
9/17	2017	0.5974	123.1	89.8
9/24	1149	0.5318	122.1	95.1
9/24	1149	0.1687	112.1	89.9
10/1	0850	1.5440	131.4	107.3
11/5	1516	0.7450	125.0	100.9

Operation Time = 137 Days

L<sub>Cdn</sub> = 46.3 dB

(b) Larson-Davis Data (Subsonic Noise)

Date	Time	Duration	SEL	L <sub>max</sub>
3/15	12:54:06	0.06	85.0	84.0
3/15	12:54:12	0.05	85.0	84.0
9/19	19:02:37	0.22	92.5	88.0

Operation Time = 116 Days

L<sub>Cdn</sub> = 23.8 dB

Table 14  
Cumulative Noise Exposure

Site	Number of Sonic Booms	Booms Per Day	$L_{Cdn}$	Number of Subsonic Noises	Events Per Day	$L_{dn}$
0	16	0.13	44.3	3	0.10	31.5
1	18	0.20	49.9	--	---	---
2	12	0.11	46.3	19	0.13	32.8
3	5	0.04	42.4	6	0.06	31.6
4	5	0.03	36.1	5	0.03	35.7
5	2	0.01	37.8	4	0.02	28.9
6	0	0	---	2	0.02	23.8
7	5	0.04	39.5	1	0.01	13.0
8	6*	0.05	50.9	10	0.12	35.5
9	17	0.12	46.3	3	0.03	23.8

\* Two events were at night, subject to 10 dB penalty.

## REFERENCES

1. "Record of Decision, Gandy Range Extension EIS", 14 March 1986.
2. ANSI S1.4 (1983), American National Standard Specification for Sound Level Meters, Appendix C.
3. Mohlman, H.T., "Computer Programs for Producing Single-Event Aircraft Noise Data for Specific Engine Power and Meteorological Conditions for Use With USAF Community Noise Model (NOISEMAP)", AFAMRL-TR-83-020, Air Force Aerospace Medical Research Laboratory, Wright-Patterson Air Force Base, Ohio, April 1983.
4. Schultz, T.J., "Synthesis of Social Surveys on Noise Annoyance", *J. Acoust. Soc. Am.*, 64, 1978, 337-405.
5. "Assessment of Community Response to High-Energy Impulsive Sounds", National Research Council, Committee on Hearing, Bioacoustics, and Biomechanics, 1981.
6. Lee, R.A., Crabill, M., Mazurek, D., Palmer, B., and Price, D., "Boom Event Analyzer Recorder (BEAR): System Description", AAMRL-TR-89-035.
7. Desai, V.R., Lucas, M.J., and Moulton, C.L., "Software Developed to Support Sonic Boom Measurements at White Sands Missile Range", Wyle Research Technical Note TN 89-14, December 1989.