

NAVY EXPERIMENTAL DIVING UNIT

TECHNICAL REPORT NO.11-97

MK 24 FULL FACE MASK DIAPHRAGM RETAINER
SHROUD MODIFICATION, WITH THE EBS I AND II

K.R. MORGAN, D.E. COWGILL, and J.R. CLARKE

NOVEMBER 1997

NAVY EXPERIMENTAL DIVING UNIT



DTIC QUALITY INSPECTED 3

19971126 124



DEPARTMENT OF THE NAVY
NAVY EXPERIMENTAL DIVING UNIT

321 BULLFINCH ROAD
PANAMA CITY, FLORIDA 32407-7015

IN REPLY REFER TO:
NAVSEA TA96-037 & TA96-038

NAVY EXPERIMENTAL DIVING UNIT

TECHNICAL REPORT NO.11-97

MK 24 FULL FACE MASK DIAPHRAGM RETAINER
SHROUD MODIFICATION, WITH THE EBS I AND II

K.R. MORGAN, D.E. COWGILL, and J.R. CLARKE

NOVEMBER 1997

DISTRIBUTION STATEMENT A. Approved for public release; distribution is unlimited.

Submitted:

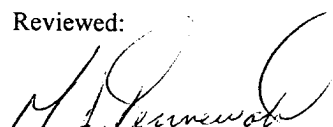

K.R. MORGAN
BMC(EOD), USN
Assistant EOD Projects Officer

Reviewed:

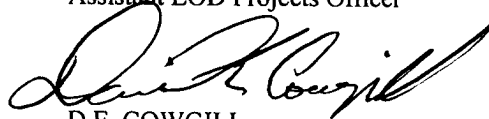

M.J. FENNEWALD
CW04, USN
EOD Projects Officer

Approved:

J.R. WILKINS III
CDR, USN
Commanding Officer

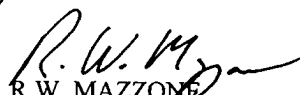
D.E. COWGILL
Eng. Technician

R.W. MAZZONE
LCDR, USN
Senior Projects Officer

J.R. CLARKE
GM-15
Scientific Director

J. NELSON
LCDR, USN
Executive Officer

REPORT DOCUMENTATION PAGE

1a. REPORT SECURITY CLASSIFICATION Unclassified		1b. RESTRICTIVE MARKINGS	
2a. SECURITY CLASSIFICATION AUTHORITY		3. DISTRIBUTION/AVAILABILITY OF REPORT DISTRIBUTION STATEMENT F: Further dissemination only as directed by Commanding Officer, Navy Experimental Diving Unit, November 1996, or higher DOD authority	
2b. DECLASSIFICATION/DOWNGRADING AUTHORITY			
4. PERFORMING ORGANIZATION REPORT NUMBER(S) NEDU TR No. 11-97		5. MONITORING ORGANIZATION REPORT NUMBER(S)	
6a. NAME OF PERFORMING ORGANIZATION Navy Experimental Diving Unit	6b. OFFICE SYMBOL (If Applicable)	7a. NAME OF MONITORING ORGANIZATION	
6c. ADDRESS (City, State, and ZIP Code) 321 Bullfinch Road, Panama City, FL 32407-7015		7b. ADDRESS (City, State, and Zip Code)	
8a. NAME OF FUNDING SPONSORING ORGANIZATION Naval Sea Systems Command	8b. OFFICE SYMBOL (If Applicable) 00C	9. PROCUREMENT INSTRUMENT IDENTIFICATION NUMBER	
8c. ADDRESS (City, State, and ZIP Code) 2531 Jefferson Davis Highway, Arlington, VA 22242-5160		10. SOURCE OF FUNDING NUMBERS	
		PROGRAM ELEMENT NO.	PROJECT NO.
		TASK NO. 96-037,038	WORK UNIT ACCESSION NO.
11. TITLE (Include Security Classification) (U) MK 24 FULL FACE MASK DIAPHRAGM RETAINER SHROUD MODIFICATION, WITH THE EBS I AND II			
12. PERSONAL AUTHOR(S) K.R. Morgan, D.E. Cowgill, and J.R. Clarke			
13a. TYPE OF REPORT Technical Report	13b. TIME COVERED FROM Sept 96 TO Nov 97	14. DATE OF REPORT (Year, Month, Day) November 1997	15. PAGE COUNT 22
16. SUPPLEMENTARY NOTATION			
17. COSATI CODES			18. SUBJECT TERMS (Continue on reverse if necessary and identify by block number) full face mask, resistive effort, total harmonic distortion, THD, resistive effort, regulator chatter, inrtance, electrical analog, modeling, PSpice, simulation
FIELD	GROUP	SUB-GROUP	
19. ABSTRACT (Continue on reverse if necessary and identify by block number) NEDU tested the utility and effectiveness of a modification to a second stage diaphragm retainer ring on the MK 24 Full Face Mask (FFM). The modification was designed to reduce regulator chatter without requiring an increase in second stage cracking pressure. The modification was tested with the FFM being used with both the Emergency Breathing System I (EBS I), and the EBS II. Regulator chatter was quantified by Total Harmonic Distortion (THD). THD was found to be inversely correlated with depth, and in most cases directly correlated with Respiratory Minute Volume (RMV). Therefore, chatter is expected to be the worst when a diver is shallow and breathing hard. At shallow depths where chatter is the greatest, the combination of the modified retainer with normal cracking pressure consistently resulted in lower chatter than did the standard diaphragm retainer with an increased cracking pressure. This was true for both the EBS I and the EBS II. Not surprisingly, the resistive effort was lower for the EBS II than the EBS I for any combination of depth and RMV. The diaphragm retainer modification had virtually no effect on resistive effort in the EBS II, and caused only a slight increase when used with the EBS I. Surprisingly, the reduction in cracking pressure allowed by the modification did not result in a decrease in early inspiratory pressure. This effect was modeled by an increase in inrtance caused by accelerating water through the four small holes in the diaphragm retainer.			
20. DISTRIBUTION/AVAILABILITY OF ABSTRACT <input type="checkbox"/> UNCLASSIFIED/UNLIMITED <input checked="" type="checkbox"/> SAME AS RPT. <input type="checkbox"/> DTIC USERS		21. ABSTRACT SECURITY CLASSIFICATION Unclassified	
22a. NAME OF RESPONSIBLE INDIVIDUAL NEDU Librarian	22b. TELEPHONE (Include Area Code) 904-230-3100	22c. OFFICE SYMBOL	

CONTENTS

	<u>Page No.</u>
Introduction	1
Methods	2
Retainer Modification	2
Statistics	4
Results	4
Wave forms	4
Dependence on depth and RMV	5
Regressions across all conditions	5
Inertance.....	6
Electrical Analog	6
Conclusions.....	16
Recommendations.....	17
References.....	18

FIGURES

<u>Figure No.</u>		<u>Page No.</u>
1	Modified Diaphragm Retainer Assembly	2
2	EBS II, Unmodified	8
3	EBS II, Standard Retainer	8
4	EBS II, Modified Retainer	9
5	EBS I, Standard Retainer	10
6	EBS I, Modified Retainer	10
7	Harmonic Distortion and Resistive Effort	11
8	Resistive Effort Estimation	13
9	Predicted %THD as a Function of Depth	14
10	Electrical Analog of the MK 24 FFM	15
11	Simulated P-V Loop	15
12	P-V Loops for Two First Stage Regulators	16

TABLES

Table No.

1	Ventilatory Parameters	3
2	EBS II Test Depths	3
3	EBS I Test Depths	4
4	Parameters for Total Harmonic Distortion	12
5	Parameters for Resistive Effort	12

INTRODUCTION

The MK 24 is a full face mask (FFM) configured to support MK 16 Underwater Breathing Apparatus (UBA) dives by Explosive Ordnance Disposal (EOD) personnel or Naval Special Warfare (SPECWAR) divers trained in SEAL Delivery Vehicles (SDVs). In the event of a rig malfunction or SDV transits requiring an alternate air source, the MK 24 is equipped with a switchover block which allows divers to alternate between the closed circuit MK 16 UBA and an open circuit second stage regulator without removing the mask.

In the EOD application, there are two sources of emergency air; the EBS I which is designed to support a diver on air at a maximum depth of 110 feet sea water (fsw), and the EBS II which supports a diver at a maximum depth of 180 fsw. In the SDV application, a diver will plug into "boat air" to conserve MK 16 UBA gas supply during SDV transits to and from a mission area.

When required to go on emergency air with the EBS I, the diver currently must remove his FFM and use a standard U.S. Divers second stage demand regulator on the end of the EBS I umbilical. Removing the FFM can be risky, especially in cold water. Navy Experimental Diving Unit (NEDU) was tasked¹ to determine if the EBS I will support decompression of a MK 16 diver in a MK 24 FFM, plugged into an EBS I with the quick disconnect fitting in lieu of the second stage regulator. This would allow the diver to plug in and go on emergency air without having to remove the FFM.

During earlier tests using the EBS II², the MK 24 FFM demand regulator typically "chattered" on inspiration (see Figure 2) when operated in the open circuit mode. This caused diver breathing discomfort and fatigue. In an attempt to minimize excessive chatter when the MK 24 FFM is operated in the open circuit mode, NEDU recommended increasing the cracking pressure of the MK 24 demand regulator from 1.0 - 1.5 inH₂O to 3 ± 1 inH₂O.

Although this approach reduced chatter, overall work of breathing suffered. A new diaphragm retainer assembly was developed by NEDU and Coastal Systems Station, Dahlgren Division, Naval Surface Warfare Center (CSS) to hydraulically dampen the venturi assist of the regulator, thereby reducing chatter. This modification allows regulator cracking pressure to be reduced to its original setting of 1.0 - 1.5 inH₂O. In addition to our original tasking¹, NEDU was tasked to determine if this "hard" diaphragm retainer assembly would eliminate or reduce free flow and "chatter" of the MK 24 FFM second stage when operated in the open circuit mode³.

This report is in response to both taskings^{1,3}. It is an evaluation of the effectiveness of the retainer modification when the MK 24 FFM is operated in the open-circuit mode. In addition, this report also evaluates the MK 24 FFM used with the EBS I using the MK 24 FFM Quick Disconnect in lieu of the currently used standard second stage regulator.

METHODS

Retainer Modification

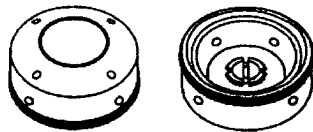
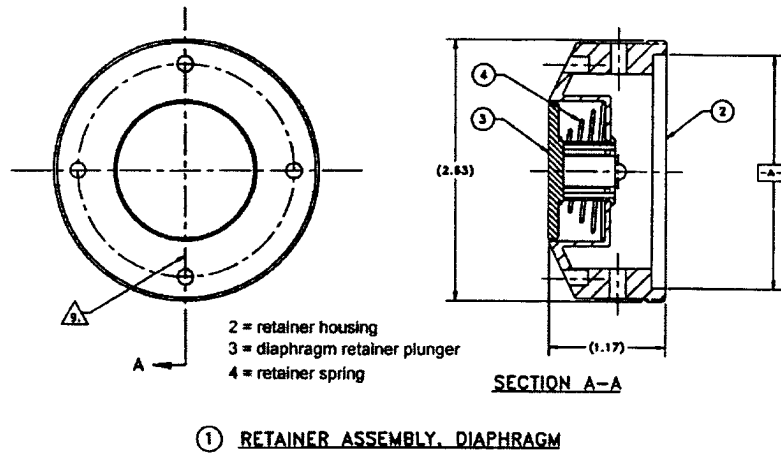

Figure 1. Modified diaphragm retainer assembly.

The new diaphragm retainer assembly (Figure 1) separates the diaphragm and demand valve lever from the open water via a water cavity. Water entry into this cavity is restricted by four small holes drilled into the retainer housing, thereby dampening the abrupt pressure change from a wave striking the regulator purge button and diaphragm. In addition, the purge button spring was stiffened to decrease its sensitivity to waves and current.

Unmanned testing was completed in four phases⁴. The first phase used the MK 24 FFM with an EBS II control console supplied with air from the NEDU test facility. The FFM was in the standard configuration using the second stage regulator without the new diaphragm retainer assembly installed and the cracking pressure set at the current PMS required 3 inH₂O. The EBS II console pressure was maintained at 135 psig over bottom. A total of 102 separate test runs were completed, not counting breathing machine calibration checks.

Phase two was conducted using the MK 24 FFM with the new diaphragm retainer assembly installed. The FFM second stage regulator cracking pressure was reduced to the original 1.0 - 1.5 inH₂O, and the EBS II console again was the air supply source. A total of 132 test runs were completed in this configuration.

In phases three and four, the FFM's were configured identically to phases one and two, however an EBS I was used instead of the EBS II. The EBS I first stage regulator

was set at 160 psig (not compensated for depth) and the twin tank bottle manifold pressure was maintained at 2500 psig. There were 81 test runs completed in Phase 3 without the modified retainer, and 86 test runs with the modification (Phase 4).

In all four phases of testing the EBS I and II were operated within the published depth limitations and pressure settings in the respective Operation and Maintenance Manuals. All tests were conducted with the test vessel water temperature set at 40° F.

At the conclusion of test phase four, three additional first stage regulators were tested at 99 fsw with the EBS I and the MK 24 FFM. The three regulators were the Poseidon Odin, DSI Superflow and the Conshelf SE. These tests allowed a comparison between the currently used Conshelf Royal and potential replacement first stage regulators that are known to have higher flow rates, better stability, and improved breathing performance.

Breathing rates, tidal volume and Respiratory Minute Volume (RMV) for each of the four test phases are listed in Table 1.

TABLE 1. Ventilatory Parameters

Breathing Rate	Tidal Volume	RMV
15 BPM	1.5 L	22.5 L/min
20 BPM	2.0 L	40 L/min
25 BPM	2.5 L	62.5 L/min
30 BPM	2.5 L	75 L/min
30 BPM	3.0 L	90 L/min

Depths for phases using the EBS II are listed in Table 2. Depths for phases using the EBS I are listed in Table 3.

TABLE 2. EBS II Test Depths

Surface
2 ATA/10 msw (33 fsw)
3 ATA/20 msw (66 fsw)
4 ATA/30 msw (99 fsw)
5 ATA/40 msw (132 fsw)
5.5 ATA/45 msw (150 fsw)

TABLE 3. EBS I Test Depths

Surface
2 ATA/10 msw (33 fsw)
3 ATA/20 msw (66 fsw)
4 ATA/30 msw (99 fsw)

Statistics

Each equipment configuration was subject to a series of five to seven dives for each depth and RMV combination. The total data set incorporating 401 tests with both total harmonic distortion⁵ (THD) and resistive effort measurements were analyzed by multiple linear regression. They were fit to the equation

$$y = A + B \cdot msw + C \cdot RMV \quad (1)$$

where y was either %THD or resistive effort. As described in reference (5), NEDU uses total harmonic distortion to quantify regulator chatter and other pressure wave form perturbations. The fitting software was SigmaStat by Jandel Scientific (San Rafael, CA). Statistical significance was assumed at an alpha level of 0.05.

RESULTS

Wave forms

Figure 2 shows a sequence of 10 pressure-volume loops taken on the original MK 24 FFM when tested with the EBS II at 10 msw and an RMV of 40 L/min. The fine black lines are the individual pressure volume tracings. Superimposed upon those tracings is the ensemble averaged P-V loop⁵. The total harmonic distortion for the ensemble averaged loop⁵ was 0.492, with the maximum possible distortion measurement being 1.0.

Figure 3 is the resulting P-V loop when cracking pressure was raised, as described in reference (2). Chatter and THD was considerably reduced. However, as evidenced by the black tracings, there was still considerable inspiratory noise.

Figure 4 is a 10 loop tracing from the MK 24 with the EBS II and the modified diaphragm retainer. Overall inspiratory noise was reduced compared to Figure 3. THD was slightly elevated compared to Figure 3 because of a pronounced oscillation at the beginning of inspiration, however the resulting THD was still far below that seen in Figure 2. The large oscillation was presumably due to an increased inertance resulting from the diaphragm modification, as explained below.

The modified retainer had the greatest influence on the MK 24 when coupled with the EBS I. In Figure 5, THD and overall inspiratory noise was a little higher with the standard configuration than in the same setup with the EBS II. However, when the

retainer was modified, the THD became very small, and inspiratory noise (evidenced by the black tracings) all but disappeared (Figure 6).

Dependence on depth and RMV

The above figures represent a single condition of depth and ventilation rate. Figure 7 is a three-dimensional scatter plot of all of the data for the 102 conditions tested with the MK 24 with the standard retainer and the EBS II, but with elevated cracking pressure (Phase 1). Percentage THD was plotted against depth and ventilation rate in the top panel, while resistive effort was plotted in the lower panel. The upper plot shows that THD typically increases directly with RMV, and increases inversely with depth. That is, the shallower the diver and the heavier the breathing, the more chattering occurs. Not surprisingly, resistive effort increases directly with both depth and ventilation rate, as seen in the lower panel.

Regressions across all conditions

Table 4 shows for all of the tested configurations (Phases 1-4) the best estimate and standard error of the estimate for each of the three coefficients in Equation (1) relating THD to msw and RMV. The table also provides measures of the overall goodness of fit (the F value and probability level, P). The sign of the B coefficient was consistently negative, showing that in general the trend seen in Figure 7 was carried out across all tested configurations. Table 5 shows similar values for the multiple linear fit of resistive effort against depth and RMV. In this case, all coefficients were positive in sign.

The resulting linear regressions for resistive effort are plotted in Figure 8, with four graphs covering the RMV range from 22.5 L/min to 90 L/min. The regressions for tests with the EBS II (solid and dotted lines) lay consistently below those for the EBS I (dashed lines). The modification had virtually no effect on resistive effort with the EBS II, but consistently increased resistive effort in the EBS I. In general, the changes caused by the standard and modified retainers remained consistent regardless of ventilation rate.

Figure 9 shows the linear regressions for %THD. At shallow depths where chattering is most severe, the modified diaphragm retainer reduced %THD in both the EBS I and II. An example of this effect can be seen by comparing Figures 5 and 6. At depth, the effect of the modification reverses. However, chatter is reduced by the increased gas density and reduced gas compressibility at depth, so that the effect of the modification is relatively unimportant. These trends apply to both moderate and high ventilatory rates, although the effect of the modification on chatter in the EBS I is considerably reduced at very high ventilation rates.

Although modification of the retainer causes a moderate increase in the resistive effort of the EBS I, the benefit of that increase is a markedly reduced THD at shallow depths where chatter is most prominent.

Inertance

Contrary to initial expectations, even though the retainer modification allowed cracking pressure to be reduced during regulator set up, that did not translate into a reduction in the early inspiratory pressure when the mask was tested dynamically. This is best demonstrated by comparing Figure 4 to Figure 3, and comparing Figure 6 to Figure 5. This result can be explained by the added inertance of the retainer modification, where the inertance comes from accelerating water through the small ports of the retainer ring (Figure 1).

Inertance is that property of a system that resists acceleration of masses within the system. It is related linguistically and mechanistically to inertia. The inertance (I) of a fluid in a cylindrical tube such as the trachea or a UBA breathing hose is defined as:

$$I = \frac{m}{A^2}$$

where m is the mass of the fluid in motion, and A is the cross-sectional area of the tube. An alternative expression is:

$$I = \frac{\rho \cdot L}{A}$$

where ρ is fluid density, and L is the length of the tube.

While the NEDU/CSS retainer modification provides hydraulic dampening which helps suppress chattering, the added inertance of accelerating water causes a large increase in pressure at the beginning of inspiration where the water acceleration is the greatest. Fortunately, high pressures early in inspiration are generally better tolerated by divers than is regulator chatter, so the overall effect is beneficial.

Electrical Analog

The effect of inertance can be demonstrated quantitatively by using electrical analogs of the MK 24 FFM and the modified retainer. Figure 10 is a schematic of one such model, and Figure 11 shows a simulated pressure-volume loop generated by solving the resulting set of differential equations using a computer program based on the PSPICE circuit analysis routines generated by the University of California at Berkeley. The particular software used for this simulation was a commercial version of PSpice (PSpice Basics ver. 7.1 by MicroSim Corporation, Irvine, CA).

Figure 11 replicates the essential features of Figure 6 with the exception of random expiratory noise. Initial inspiratory and expiratory pressures do not rise instantaneously, but slope to the right or left (respectively) due to the shunting

compliance of the FFM. The early spikes in pressure at the beginning of both inspiration and expiration are due to the interaction between FFM compliance, and the resistance and inertance of the diaphragm retainer.

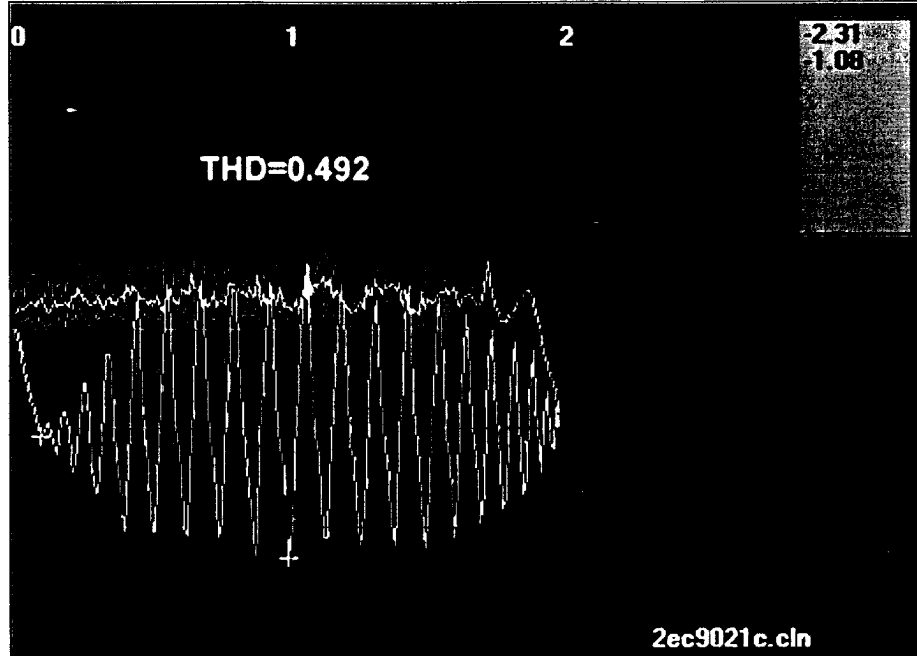

Figure 2. EBS II, MK24, unmodified. 10 msw, 40 L/min RMV.

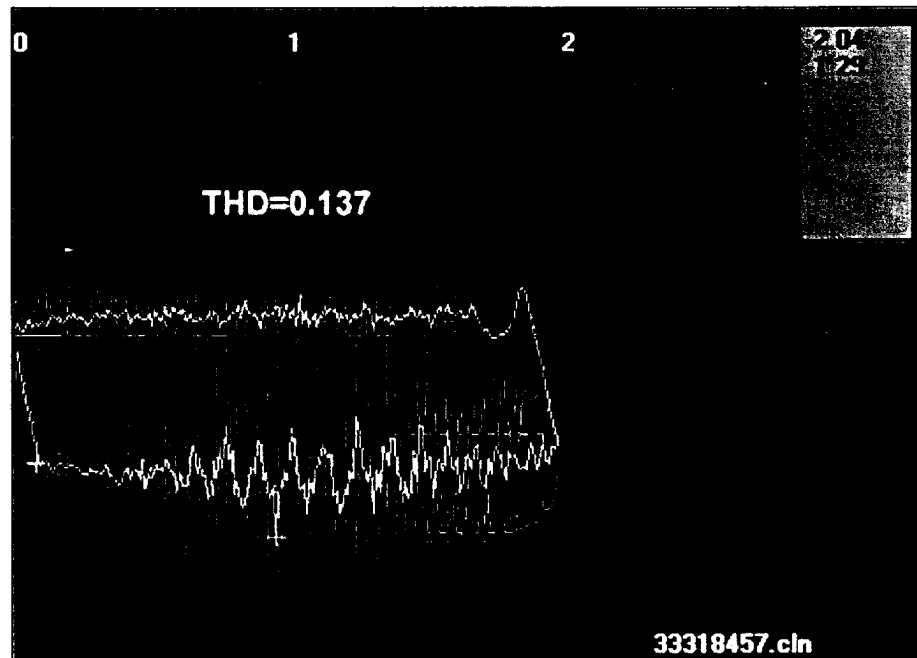

Figure 3. EBS II, MK24, standard retainer with raised cracking pressure. 10 msw, 40 L/min RMV.

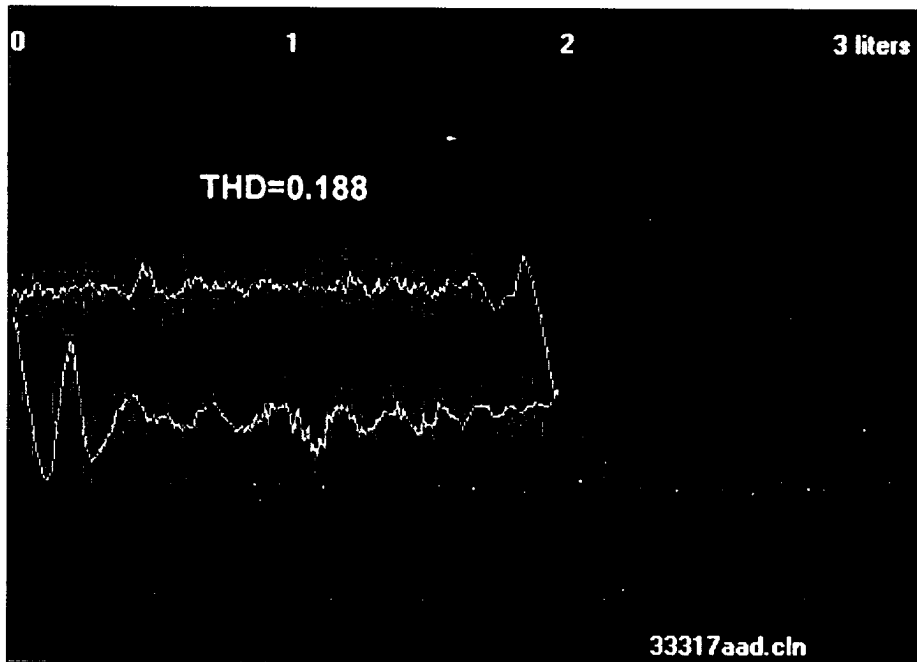

Figure 4. EBS II, MK24, modified retainer. 10 msw, 40 L/min RMV.

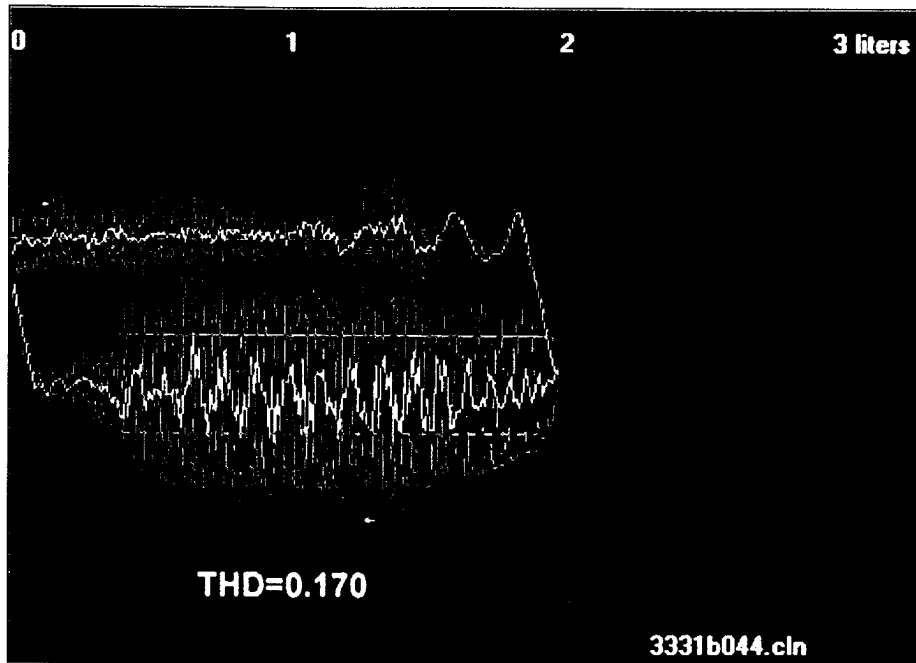

Figure 5. EBS I, MK24, standard retainer. 10 msw, 40 L/min RMV.

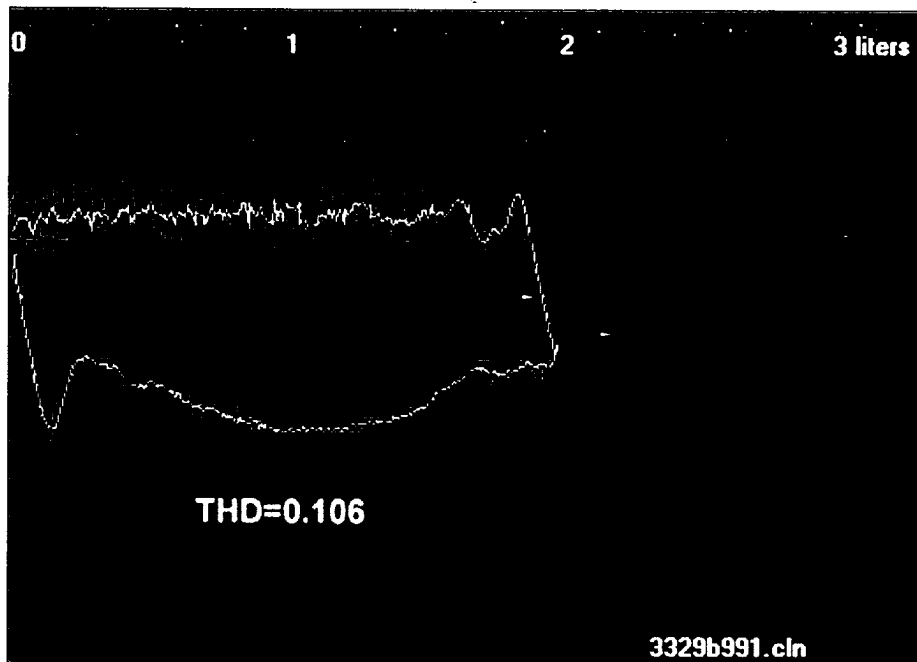

Figure 6. EBS I, MK24, modified retainer. 10 msw, 40 L/min RMV.

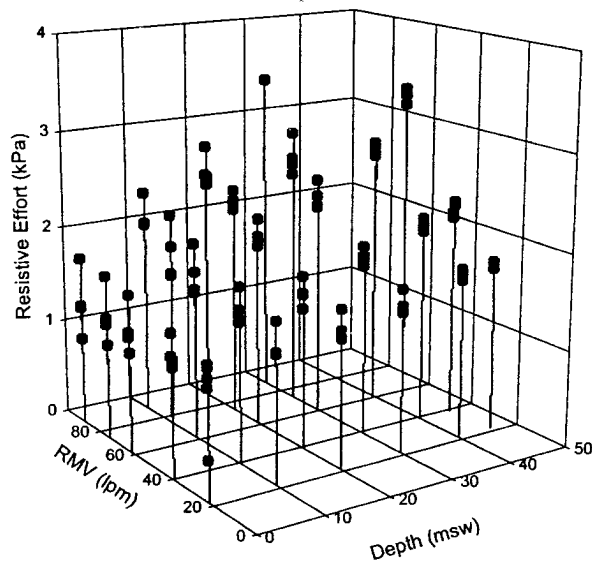
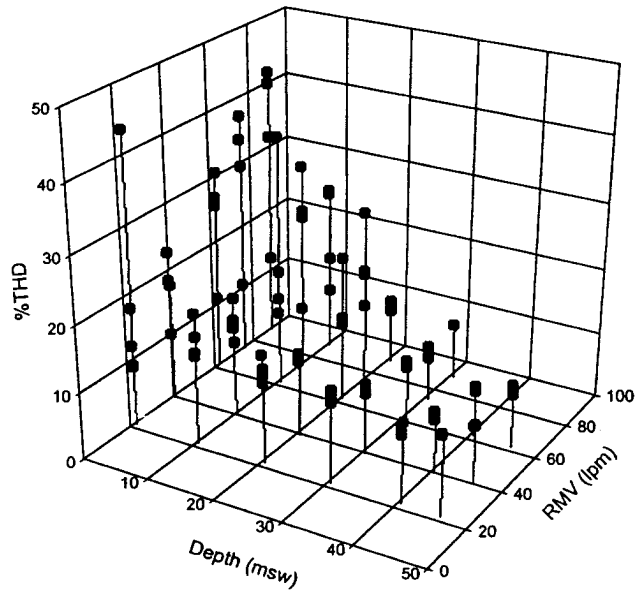

Figure 7. %Harmonic distortion (top panel) and resistive effort (bottom panel) for the MK24 with increased cracking pressure and the EBS II (Phase 1).

Table 4. Parameters for the multiple linear fit of Total Harmonic Distortion to depth in msw and ventilation in L/min.

%THD								
PHASE (n)	A		B x msw		C x RMV		F	P
	coef	SE	coef	SE	coef	SE		
1 (102)	19.872	2.132	-0.316	0.0446	0.0345	0.0300	29.164	<0.001
2 (132)	16.600	0.518	-0.108	0.0102	0.0117	0.0071	69.255	<0.001
3 (81)	17.707	0.958	-0.347	0.0619	--	--	31.349	<0.001
4 (86)	10.096	0.782	-0.114	0.0269	0.0550	0.0117	26.328	<0.001

n = number of runs, coef = best fit coefficient (parameter), SE = standard error of the estimate, F = F value (measure of fit to the data), P = probability that an F of the given size would be found by random sampling if there was no relationship among the various variables (%THD, msw, and RMV).

Table 5. Parameters for the multiple linear fit of Resistive Effort to depth in msw and ventilation in L/min.

Resistive Effort								
PHASE (n)	A		B x msw		C x RMV		F	P
	coef	SE	coef	SE	coef	SE		
1 (102)	0.469	0.0918	0.0289	.00192	0.0151	.00129	149.29	<0.001
2 (132)	0.419	0.0838	0.0241	0.0017	0.0170	0.0012	165.77	<0.001
3 (81)	0.289	0.137	0.0551	0.0044	0.0185	0.0020	94.23	<0.001
4 (86)	0.370	0.109	0.0591	.00375	0.0195	.00164	158.94	<0.001

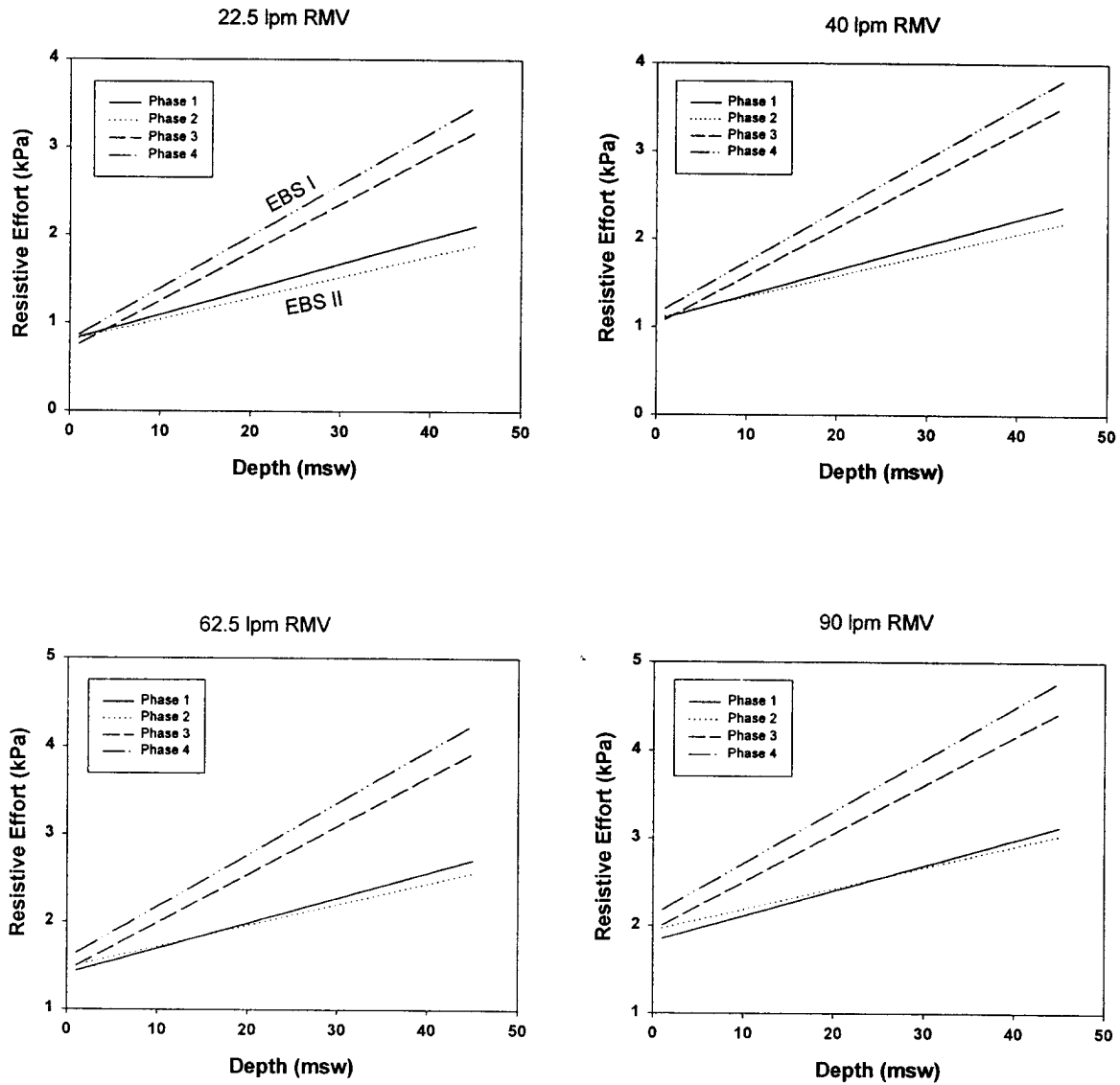

Figure 8. Resistive Effort estimation for various ventilation rates.

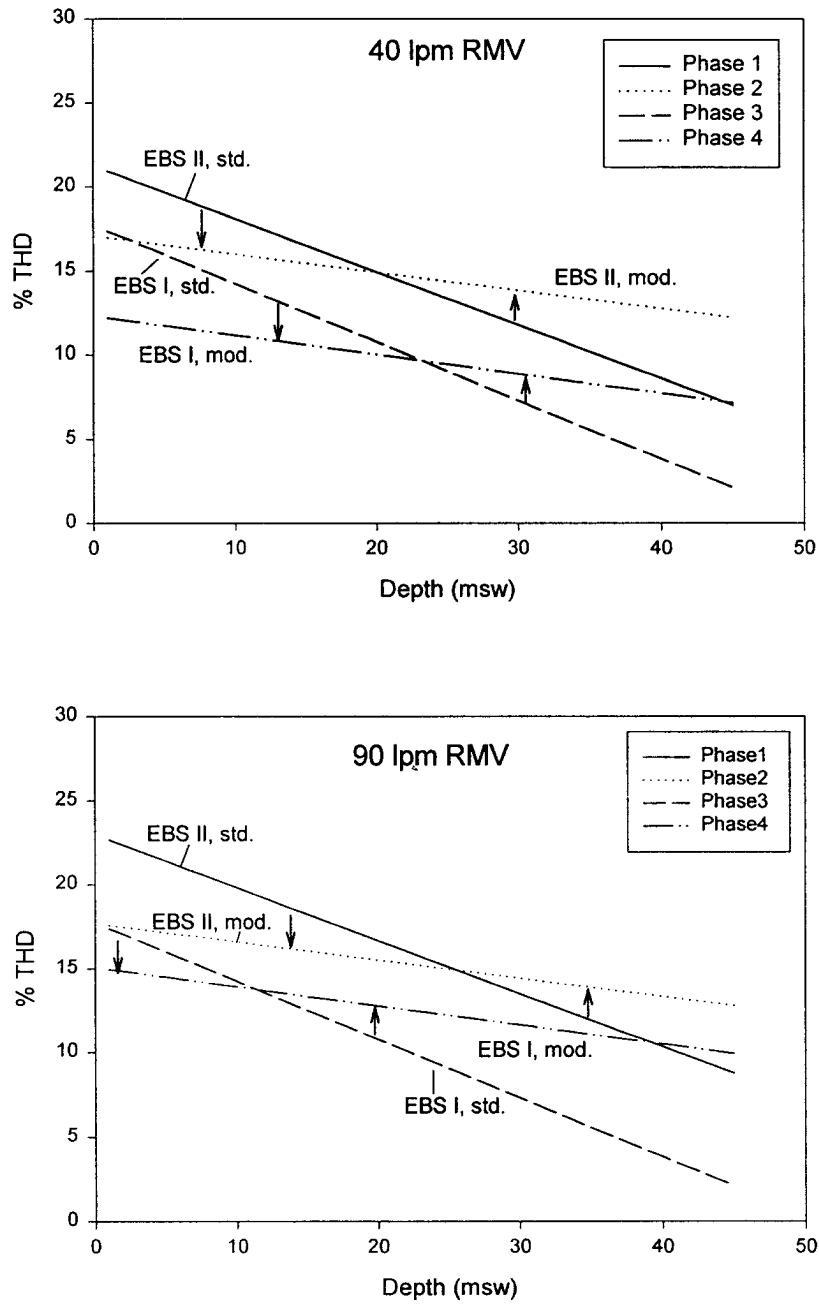

Figure 9. Predicted %THD as a function of depth for all configurations. Arrows show the direction of predicted change when switching from standard to modified retainers.

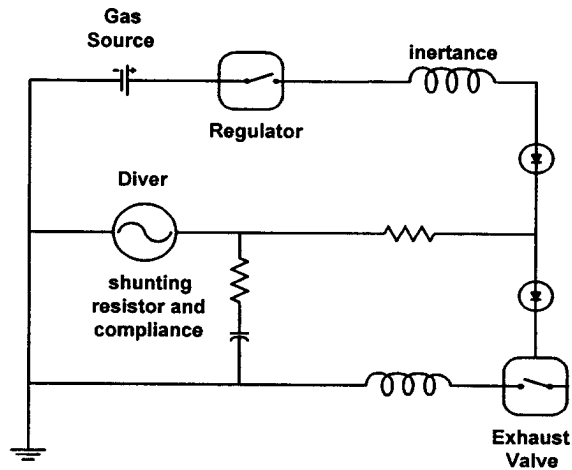

Figure 10. Electrical analog of the MK 24 FFM.

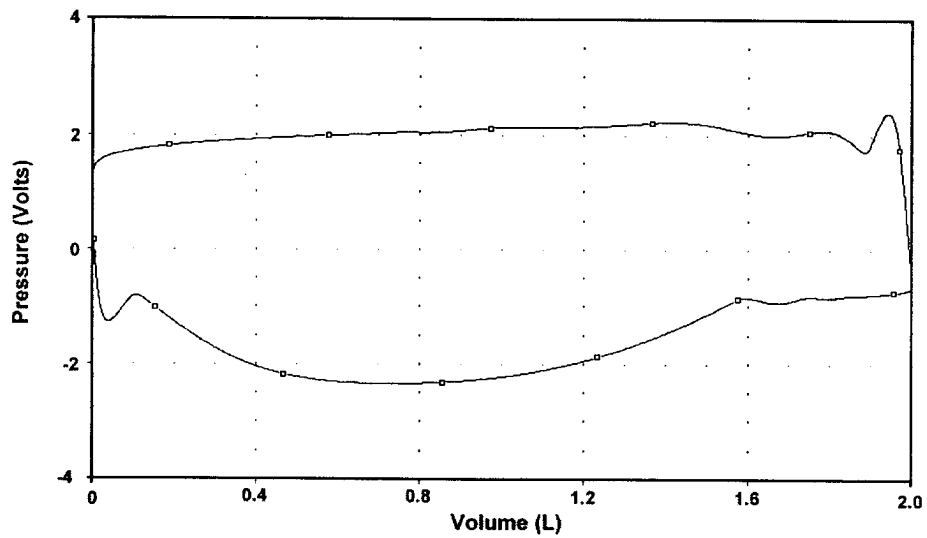

Figure 11. Simulated P-V loop for the above analog. Compare to Figure 6. (Model parameters: source voltage = 2.8v, constant current source=1A, $R_{insp}=3$ ohms, $R_{exp}=0.2$ ohms, $L_{insp}=400$ mH, $L_{exp}=150$ mH, $C=4$ mF, $R_{shunt}=0.5$ ohm.)

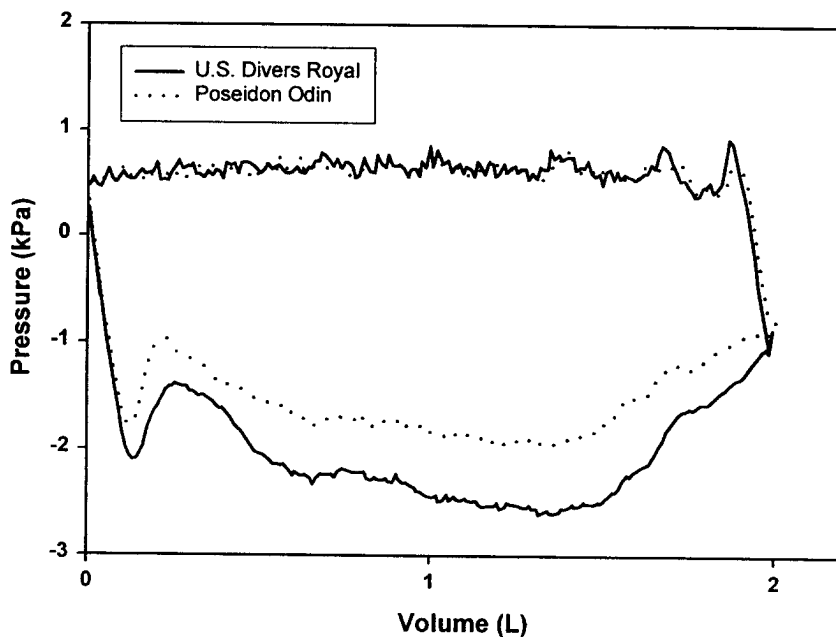

Figure 12. P-V loops for two first stage regulators on the EBS I with the MK 24 with modified retainer at 30.3 msw and 40 L/min RMV.

Figure 12 shows that for the MK 24 FFM on EBS I with a Poseidon Odin first stage, inspiratory pressure was reduced compared to a loop from a Conshelf Royal first stage. Similar results applied to the DSI Superflow first stage. The resistive efforts were 2.09, 2.19, and 2.53 kPa for the Odin, DSI, and Royal regulators, respectively.

CONCLUSIONS

The NEDU/CSS modified retainer improved upon the chatter reducing technique published in reference (5), while allowing a reduction in regulator cracking pressure. It caused either no, or at most moderate, increase in resistive effort. Unexpectedly, it did not reduce pressure during the initiation of inspiration.

The MK 24 Full Face Mask when used with the EBS I will support a diver undergoing decompression at a depth of 100 ft. At 22.5 L/min RMV (diver performing

light work) the resistive effort was just over 2 kPa at the operational depth limit of the EBS I. Since a diver with a rig malfunction needing an emergency gas supply is expected to be at rest or performing light work, the MK 24/EBS I configuration would be acceptable.

Regulator chatter on inspiration is directly related to flow rate and inversely related to depth. Increases in flow resistance and inertance contribute to the suppression of chatter.

The Poseidon Odin and DSI Superflow first stage regulators are better performers than the currently used Conshelf Royal⁵. Replacement of the Royal with either the Odin or Superflow should reduce a diver's breathing effort with the EBS I. In addition, the Poseidon Odin is currently the Navy's premier performing cold weather first stage and provides good control stability and breathing performance with the EBS I. Logistic support for the Royal is also a consideration. The Royal is no longer manufactured and the current stock of repair/replacement parts is limited.

RECOMMENDATIONS

1. NEDU recommends approval of the MK 24 FFM and the FFM quick disconnect for use with both the EBS I and the EBS II.
2. NEDU recommends approval of the new diaphragm retainer assembly with the MK 24 FFM.
3. NEDU recommends replacement of the currently used Conshelf Royal with the Poseidon Odin for use with the EBS I.

REFERENCES

1. Naval Sea Systems Command, Task Assignment 96-037, *Testing of the EBS I with the MK 24 Full Face Mask*, 13 Nov 96.
2. Crepeau, L.J., *Eliminating Chatter in the MK 24 Full Face Mask by Adjusting Demand Lever Free Play and Inhalation Cracking Pressure*, NEDU TR 2-95, Navy Experimental Diving Unit, Feb 95 (Limited Distribution).
3. Naval Sea Systems Command, Task Assignment 96-038, *Testing of the New Diaphragm Retainer Shroud for the MK 24 Full Face Mask*, Navy Experimental Diving Unit, 24 Oct 96.
4. Morgan K. R. and Junker D. L., *Evaluation of the MK 24 Full Face Mask with the New Diaphragm Retainer Assembly Installed, Used with the EBS I and the EBS II*, NEDU TP 97-11, Navy Experimental Diving Unit, March 97 (Limited Distribution).
5. Navy Experimental Diving Unit, *U.S. Navy Unmanned Test Methods and Performance Goals for Underwater Breathing Apparatus*, TECH MAN 01-94, June 1994.
6. Navy Experimental Diving Unit letter 3963/TA96-037 Ser 03E/211 of 8 May 97, *Evaluation of the EBS I with the MK 24 FFM*