

**US Army Corps
of Engineers**

Waterways Experiment
Station

Technical Report REMR-CO-18
August 1997

Repair, Evaluation, Maintenance, and Rehabilitation Research Program

Preliminary 3-D Testing of CORE-LOC™ as a Repair Concrete Armor Unit for Dolos-Armored Breakwater Slopes

by George F. Turk, Jeffrey A. Melby

Approved For Public Release; Distribution Is Unlimited

19971126 121

EXEMPT FROM AUTOMATIC DOWNGRADING AND DECLASSIFICATION

Prepared for Headquarters, U.S. Army Corps of Engineers



The following two letters used as part of the number designating technical reports of research published under the Repair, Evaluation, Maintenance, and Rehabilitation (REMR) Research Program identify the problem area under which the report was prepared.

<u>Problem Area</u>		<u>Problem Area</u>	
CS	Concrete and Steel Structures	EM	Electrical and Mechanical
GT	Geotechnical	EI	Environmental Impacts
HY	Hydraulics	OM	Operations Management
CO	Coastal		

The contents of this report are not to be used for advertising, publication, or promotional purposes. Citation of trade names does not constitute an official endorsement or approval of the use of such commercial products.

The findings of this report are not to be construed as an official Department of the Army position, unless so designated by other authorized documents.



PRINTED ON RECYCLED PAPER

Preliminary 3-D Testing of CORE-LOC™ as a Repair Concrete Armor Unit for Dolos-Armored Breakwater Slopes

by George F. Turk, Jeffrey A. Melby

U.S. Army Corps of Engineers
Waterways Experiment Station
3909 Halls Ferry Road
Vicksburg, MS 39180-6199

Final report

Approved for public release; distribution is unlimited

Prepared for U.S. Army Corps of Engineers
Washington, DC 20314-1000

Under Work Unit 32662



**US Army Corps
of Engineers
Waterways Experiment
Station**

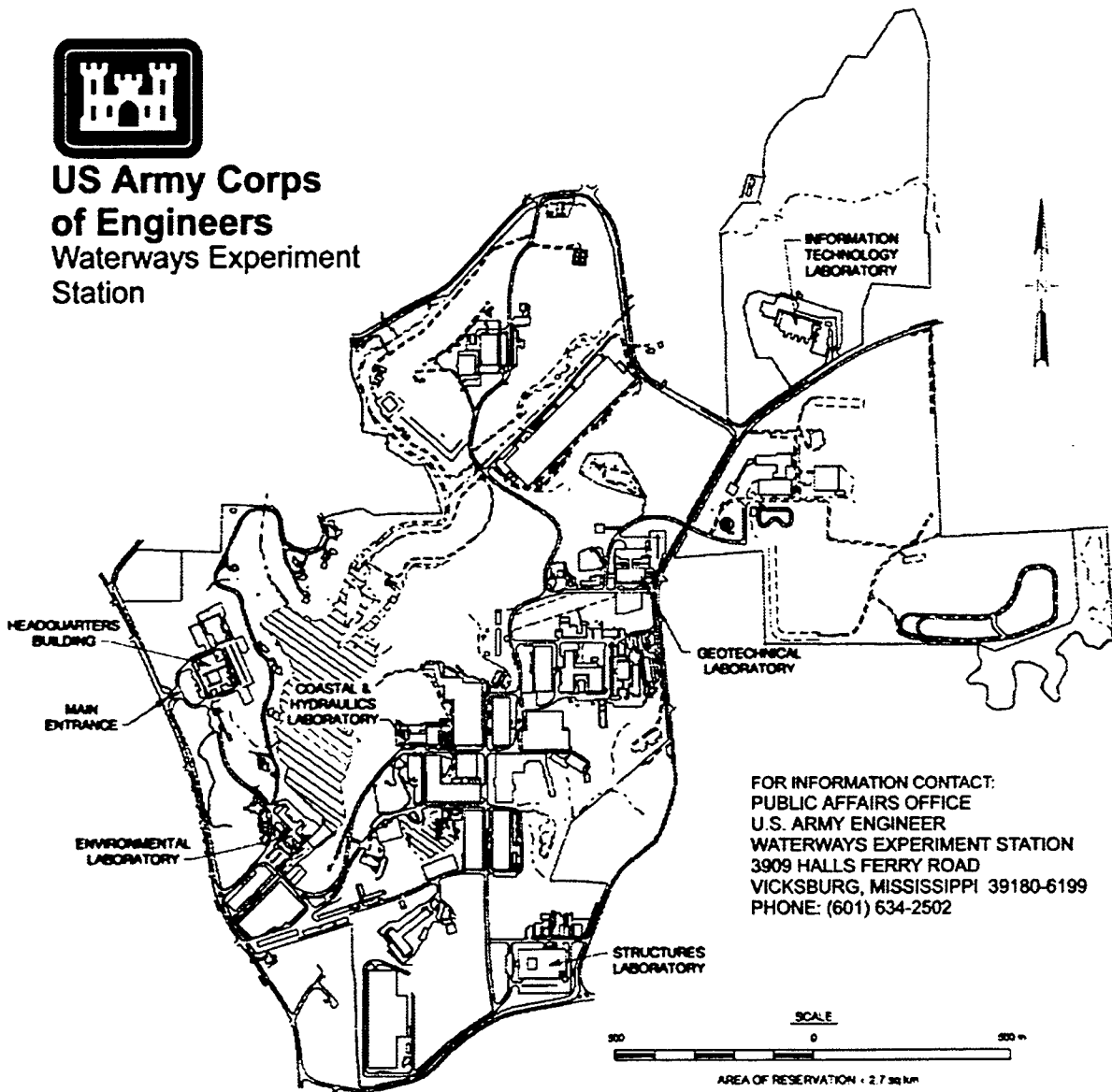

Waterways Experiment Station Cataloging-in-Publication Data

Turk, George F.

Preliminary 3-D testing of CORE-LOC as a repair concrete armor unit for dolos-armed breakwater slopes / by George F. Turk, Jeffrey A. Melby ; prepared for U.S. Army Corps of Engineers.

46 p. : ill. ; 28 cm. -- (Technical report ; REMR-CO-18)

Includes bibliographic references.

1. Dolomite -- Repairing -- Evaluation. 2. Breakwaters -- Repairing -- Evaluation. 3. Concrete -- Repairing -- Equipment and supplies -- Testing. I. Melby, Jeffrey A. II. United States. Army. Corps of Engineers. III. U.S. Army Engineer Waterways Experiment Station. IV. Repair, Evaluation, Maintenance, and Rehabilitation Research Program. V. Title. VI. Series: Technical report (U.S. Army Engineer Waterways Experiment Station) ; REMR-CO-18.

TA7 W34 no.REMR-CO-18

Contents

Preface	v
1—Introduction	1
Background	1
Repair of Dolos-Armored Slopes	1
Purpose of the Study	3
2—Three-Dimensional Repair Tests	4
The Model	4
Test Procedures	11
3—Repair Test Results	14
Test Sequence 1 ($T_p = 1.41$ sec)	14
Test Sequence 2 ($T_p = 1.41$ sec)	16
Test Sequence 3 ($T_p = 1.84$ sec)	17
Test Sequence 4 ($T_p = 1.84$ sec)	18
Test Sequence 5 ($T_p = 2.4$ sec)	19
Test Sequence 6 ($T_p = 2.4$ sec)	20
Test Sequence 7 ($T_p = 2.83$ sec)	21
Test Sequence 8 ($T_p = 2.83$ sec)	21
4—Discussion of Results	24
5—Summary and Conclusions	26
Summary	26
Conclusions	26
References	29
Appendix A: Photographs of 3-D Repair Tests	A1

SF 298

List of Figures

Figure 1. Methods for repairing concrete-armored breakwaters, (a) spot repair method (SRM), (b) V-notch method (VNM)	3
--	---

Figure 2.	Typical cross section of the breakwater	4
Figure 3.	Dolos and Core-Loc dimensions	6
Figure 4.	Illustration of Core-Loc and dolos armor matrix	7
Figure 5.	Plan view of offshore breakwater tested. Note position of wave maker and head section divided into four quadrants	8
Figure 6.	Wave calibration for $T_p = 1.41$ sec	9
Figure 7.	Wave calibration for $T_p = 1.84$ sec	9
Figure 8.	Wave calibration for $T_p = 2.40$ sec	10
Figure 9.	Wave calibration for $T_p = 2.83$ sec	10
Figure 10.	Illustration of Core-Loc suspended from crane by slings	13
Figure 11.	Duration of wave attack the original dolosse armor withstood compared to the Core-Loc-repaired structure for Test Sequences 1-8	23

List of Tables

Table 1.	Model Material Sizes	7
Table 2.	Results from Repair Test Sequence 1 ($T_p = 1.41$ sec)	15
Table 3.	Results from Repair Test Sequence 2 ($T_p = 1.41$ sec)	16
Table 4.	Results from Repair Test Sequence 3 ($T_p = 1.84$ sec)	17
Table 5.	Results from Repair Test Sequence 4 ($T_p = 1.84$ sec)	19
Table 6.	Results from Repair Test Sequence 5 ($T_p = 2.40$ sec)	20
Table 7.	Results from Repair Test Sequence 6 ($T_p = 2.40$ sec)	21
Table 8.	Results from Repair Test Sequence 7 ($T_p = 2.83$ sec)	22
Table 9.	Results from Repair Test Sequence 8 ($T_p = 2.83$ sec)	22

Preface

This report was prepared as part of the Coastal Problem Area of the Repair, Evaluation, Maintenance, and Rehabilitation (REMR) Research Program. The work was carried out under Work Unit 32662, "Breakwater Concrete Armor Units for Repair." For the REMR Program, Coastal Problem Area Monitor is Mr. John H. Lockhart, Jr., Headquarters, U.S. Army Corps of Engineers (HQUSACE). REMR Program Manager is Mr. William F. McCleese of the U.S. Army Engineer Waterways Experiment Station's (WES's) Structures Laboratory, and Coastal Problem Area Leader is Mr. D. D. Davidson of WES's Coastal and Hydraulics Laboratory (CHL). Dr. Tony C. Liu was the REMR Coordinator for the Directorate of Research and Development, HQUSACE. The REMR Overview Committee at HQUSACE consisted of Dr. Liu (CERD-C) and Mr. Harold C. Tohlen (CECW-O).

Model tests were conducted at WES during September-December 1994 by personnel of the Wave Research Branch (WRB) of the Wave Dynamics Division (WDD), CHL, under the direction of Dr. James R. Houston and Mr. Charles C. Calhoun, Jr., Director and Assistant Director of CHL, respectively; and the direct guidance of Messrs. C. E. Chatham, Jr., Chief of WDD; and Mr. D. D. Davidson, Chief of WRB. Tests were conducted by Messrs. George F. Turk, Jeffrey A. Melby, C. Ray Herrington, and Johnny Heggins, CHL; and Mr. David Daily of the WES Instrumentation Services Division. This report was prepared by Messrs. Turk and Melby.

At the time of publication of this report, Director of WES was Dr. Robert W. Whalin. Commander of WES was COL Bruce K. Howard, EN.

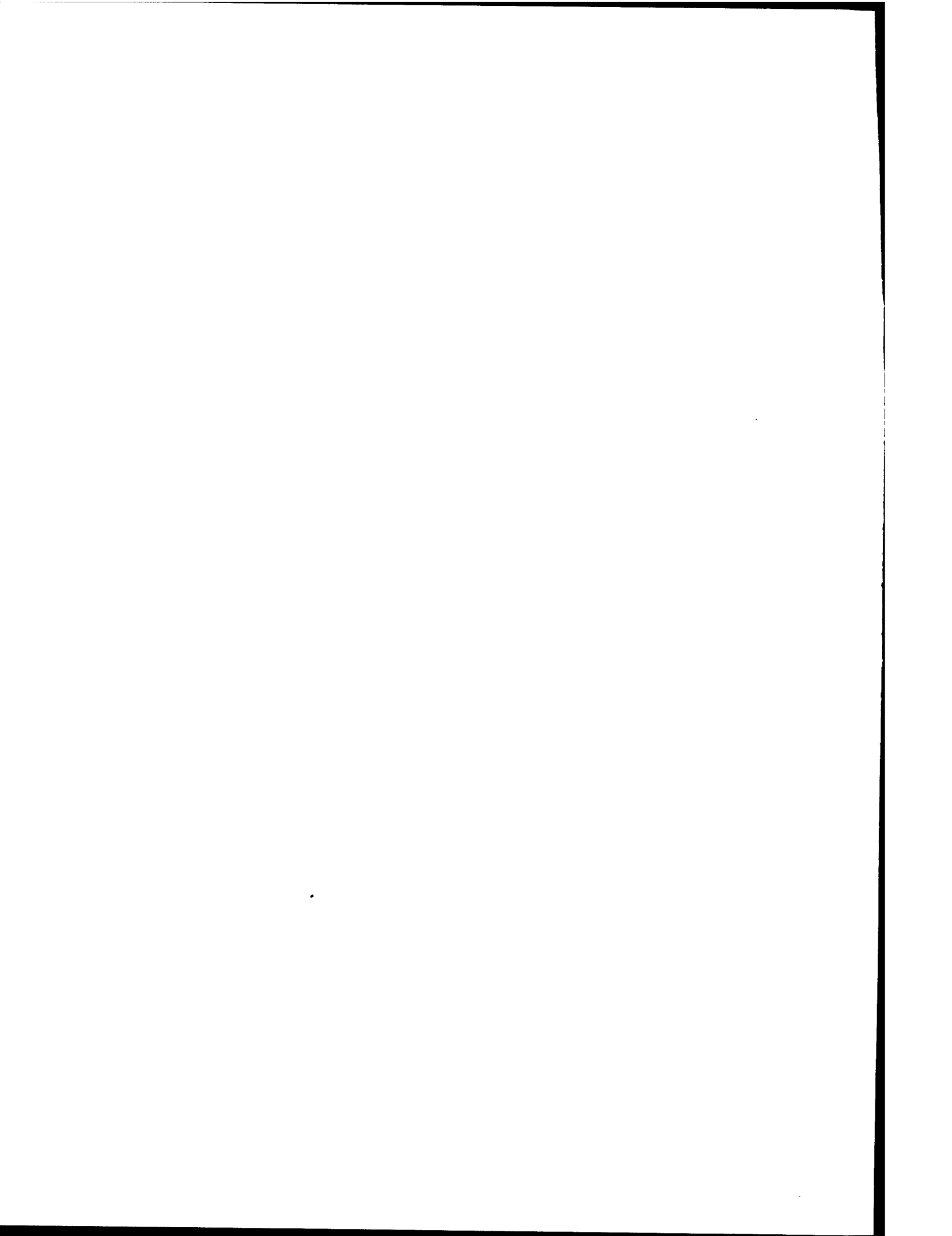

1 Introduction

Background

The U.S. Army Corps of Engineers has built and maintains 19 major concrete-armored breakwaters in the continental United States and Hawaii. During 1992-94, many of these structures were surveyed to assess both the hydraulic and structural performance of the concrete armoring (Melby and Turk 1995a). Maintenance of some of these structures has substantially exceeded original estimates, and much speculation has been made as to the causes of premature armor failure. Some of the possible reasons are:

- a.* Construction placement practice.
- b.* Armor concrete strength and quality.
- c.* Reinforcement scheme.
- d.* Breakwater configuration.
- e.* Cross-sectional variations.
- f.* Uncertainty in local wave climate.
- g.* Rehabilitation methods.

Most of the Corps' concrete-armored structures are armored with dolosse, and many have been rehabilitated with additional dolosse of equal or larger size. Some dolos-armored slopes repaired with dolosse show only a marginal increase in performance over the original armoring, and may require additional maintenance.

Repair of Dolos-Armored Slopes

Maintenance and repair of concrete-armored slopes poses an entirely different set of challenges from original armor construction. Depending on the degree of damage to the armoring, the method of repair may vary. The type

of damages seen on dolos slopes can be classified as individual unit or cluster breakage, unraveling, or transition instability.

Single unit breakage can be evenly dispersed on the slope or can progress into cluster breakage. A properly designed concrete armored breakwater will exhibit some of this type breakage. It is uneconomical to design an armor slope where 100 percent of the armor units remain intact throughout the design life of the structure. For a properly designed armor layer, a small amount of breakage is acceptable over the structure's design life.

Cluster breakage is characterized by localized damage progression where units break but remain in the vicinity of their original placement. This type of breakage starts with a single armor unit. Over time, the damage progresses because units adjacent to the failed unit become unconstrained and begin rocking. The resulting unit-to-unit impacts cause accelerated breakage of surrounding armor.

Unraveling occurs when units are placed such that there is inadequate interlocking or when units are underdesigned with respect to weight. Inadequate interlocking can be due to armor unit design, inadequate randomness, or a low packing density of armor. It is characterized by unstable units displacing from their original positions, thus unconstraining adjacent units. These newly unconstrained units displace, causing more units to become unconstrained, and they displace. The armor layer unravels. Unraveling can occur concurrently with cluster breakage.

Transition instability occurs at the boundaries of the armor matrix. One critical transition is found at the toe of the structure where concrete armoring rests on the seabed. Units along the toe are vulnerable to scour and displacement. Lateral transitions are the interfaces between dissimilar armor unit types or sizes, and where the concrete armoring terminates along the alignment. It is often difficult to achieve adequate interlocking between dissimilar armor. Crown transitions occur on structures with caps, where the armor units are buttressed against a solid concrete surface. Unless the armor units are integrated into the cap, they are susceptible to movement and breakage. Strict attention should be paid to placement of armor at transitions because, in general, damage is more likely to occur at these locations.

Two methods for repairing concrete armoring have been identified. The authors of this report refer to them as: the spot repair method (SRM) and V-notch method (VNM) (Figure 1). The SRM can be used for the repair of cluster breakage. For these cases, the broken armor units are removed from the slope and replaced with new armor. The VNM is a more extensive repair than the SRM whereby the armoring is completely stripped away in the distressed area. The stripped-away notched area extends down the slope to the lowest point of distress and may reach to the toe itself. The notch then is reconstructed using either new units exclusively or a mixture of original intact units and new ones.

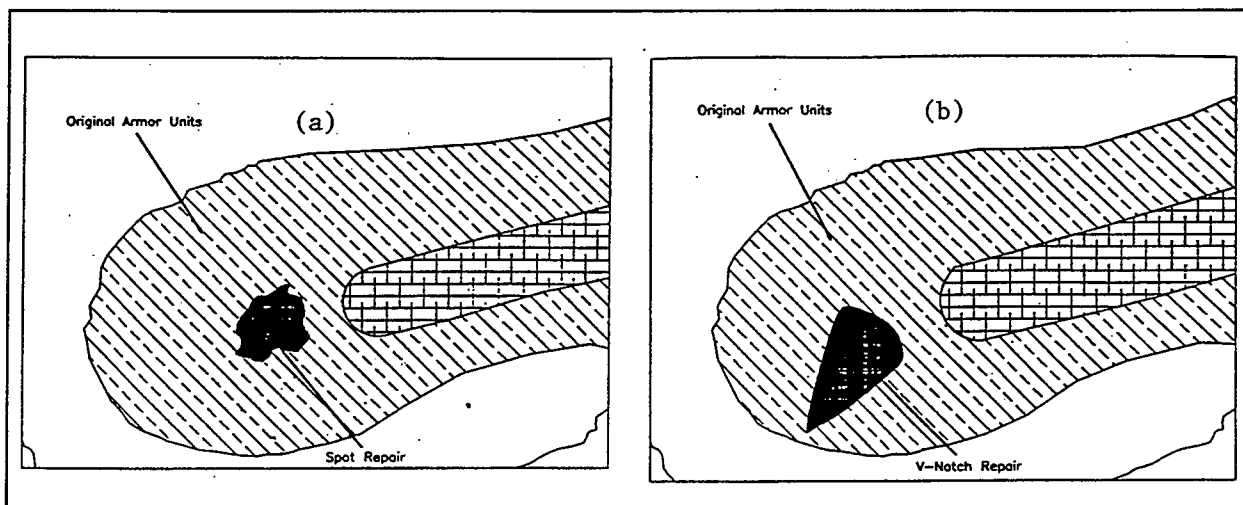

Figure 1. Methods for repairing concrete-armored breakwaters, (a) spot repair method (SRM), (b) V-notch method (VNM)

Purpose of the Study

This study is the first evaluation of the potential of the CORE-LOCTM (Core-Loc) concrete armor unit to repair dolos-armored breakwater slopes. It is based on the results of three-dimensional physical model testing. The U.S. Army Engineer Waterways Experiment Station is investigating the Core-Loc armor unit because of its superior structural and stability characteristics and its ability to interlock with dolosse (Melby and Turk 1995b).

In this report, the degradation of a dolos-armored breakwater head section is physically modeled at small scale. The modeling is done in such a way as to reproduce damage as realistically as possible without the added expense of actually scaling the structural strength of the armor units. A realistic, yet accelerated, damage rate for the armor layer deterioration was attained by sizing the units for marginal hydraulic stability. Turk and Melby (1994) showed that moving dolosse are subject to excessive impact stress from unit-to-unit contact and are very likely to fail structurally with excessive movement. For these tests, once an armor unit fully displaced from its original position it was considered broken. Assuming that broken units do not add to the inherent stability of a deteriorating section, and thus for practicality, the displaced unit was removed from the slope.

Because of time and budget constraints, this investigation focusses on the performance of Core-Loc when used to repair dolos armor using the SRM method. Future tests of Core-Loc-repaired dolos slopes using the VNM are planned.

2 Three-Dimensional Repair Tests

The Model

Three-dimensional repair tests were conducted on a geometrically undistorted model of a detached offshore breakwater in a wave basin measuring 36.6 m (120 ft) long, 24.4 m (80 ft) wide, and 1.2 m (4 ft) deep.¹ The breakwater measured 2.44 m (8 ft) from center to center between the two head sections. The structure height of the test section at the offshore head, measured from the offshore toe, was 26 cm (10.2 in.) and its slope was 1V: 1.5H (Figure 2). Only one water depth was tested and it measured, at the toe of the test section, 23 cm (9 in.). The three-dimensional model, originally constructed for the Noyo breakwater (Smith et al. 1995), was utilized for this investigation. It was constructed with a fully molded irregular bathymetry, extending approximately 3 m (10 ft) from the center line of the breakwater in all directions.

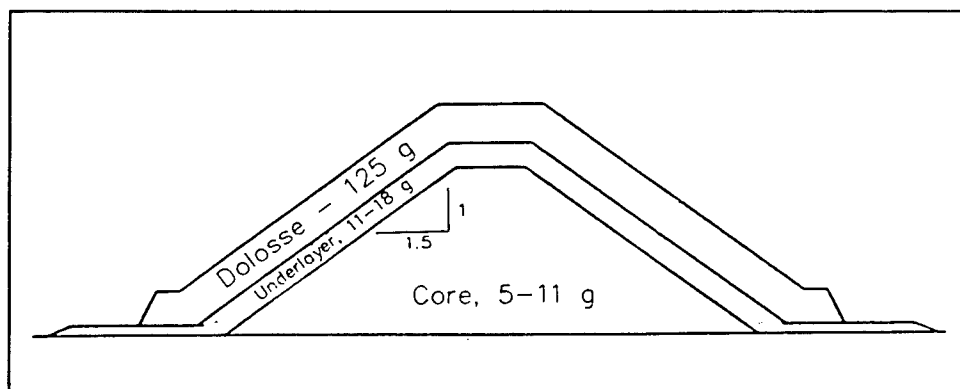

Figure 2. Typical cross section of the breakwater

¹ Units of measurement in the text of this report are shown in SI (metric) units, followed by non-SI (British) units in parentheses.

When constructing all small-scale physical models of rubble mounds, scale effects of viscous forces associated with flow through the underlayers and core of the structure are of concern. In the reproduction of prototype conditions, the model materials need to be properly sized to avoid Reynolds and other scale effects. Selected scaling was based on available armor sizes and checked for scale effects following the methods put forth by Keulegan (1973). The geometrically scaled underlayer size was found to be satisfactory. The core size, scaled from typical prototype condition, was modeled using small crushed limestone. This sizing allows for a conservative design with no transmission and maximum reflection.

The primary or initial concrete armoring was 125-g (0.276-lb) dolosse with a waist ratio, $r = 0.32$ (Figure 3a). The waist ratio is the ratio of the dolos shank width B to the fluke length C_{DO} . This fluke length C_{DO} is considered the characteristic length of a dolos. In this case, $C_{DO} = 7.1$ cm (2.78 in.) and it can be used to express the volume of an individual dolos V_{DO} where

$$V_{DO} = 0.1561 C_{DO}^3 \quad (1)$$

The packing density coefficient ϕ can be expressed as a function of the number of layers n , layer coefficient k_{Δ} , and porosity P (*Shore Protection Manual* 1984) as

$$\phi = n k_{\Delta} (1 - P/100) \quad (2)$$

The number of individual armor units N per surface area of slope A as a function of packing density ϕ and the volume of an individual unit V is then given by

$$N/A = \phi V^{-2/3} \quad (3)$$

In these tests whenever the breakwater was armored with dolosse, care was taken to place the dolosse on the slope at a packing density of $\phi = 0.83$ (or $P = 0.56$, $k_{\Delta} = 0.94$, $n = 2$).

The repair concrete armoring was 145-g (0.32-lb) Core-Loc (Figure 3b). These units have a characteristic fluke length $C_{CL} = 6.6$ cm (2.59 in.). The relationship between the volume of a Core-Loc V_{CL} and its characteristic length is

$$V_{CL} = 0.2234 C_{CL}^3 \quad (4)$$

These sizes of Core-Loc and dolosse have a ratio of Core-Loc fluke length to dolos fluke length of $C_{CL}/C_{do} = 0.932$. When the two units are placed on the slope together they are almost indistinguishable from one another

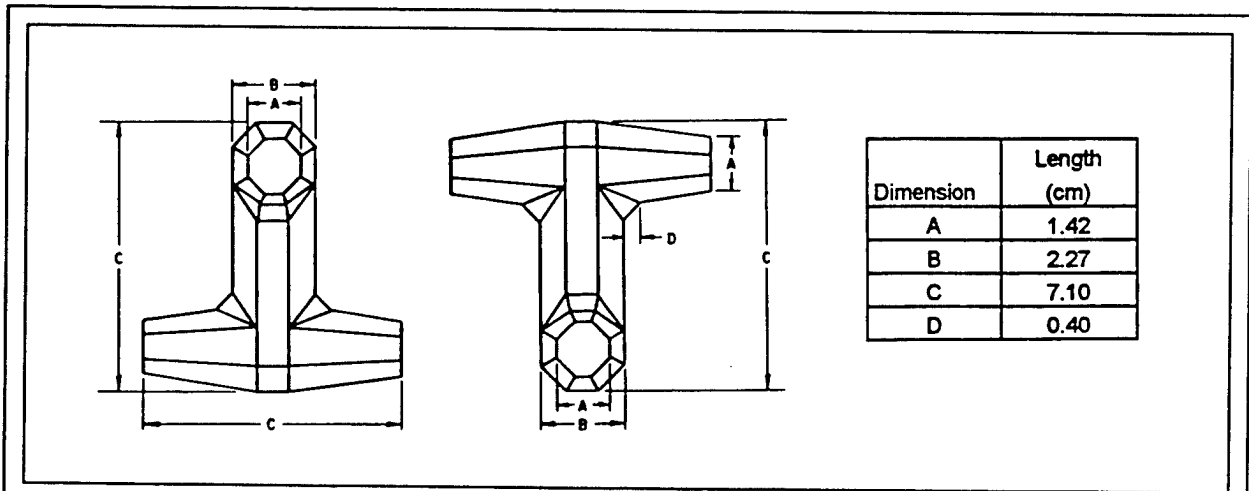

a. 125-g dolos

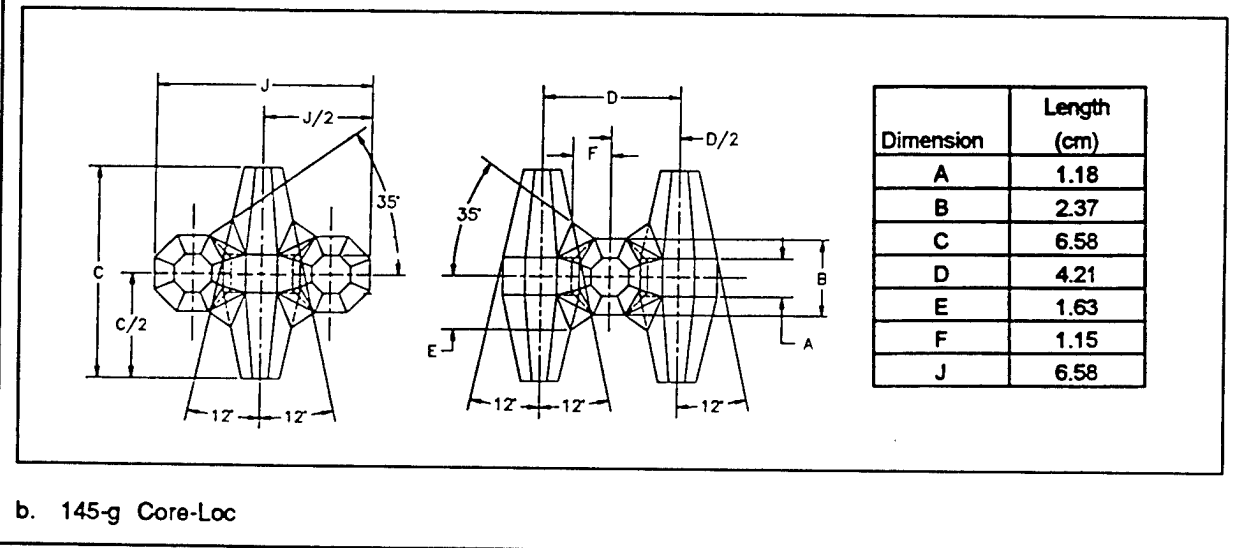

b. 145-g Core-Loc

Figure 3. Dolos and Core-Loc dimensions

(Figure 4). The sizes of model breakwater armor and underlayer materials are listed in Table 1.

Test equipment

Waves were generated by a piston type electronically controlled hydraulic wave maker. Displacement of the wave board was controlled by a command signal transmitted to the wave board by a Digital Equipment Corporation (DEC) MicroVax II computer. Waves were produced by the periodic displacement of the wave board. Irregular wave tests were conducted where command signals to drive the wave board were generated to simulate a Texel

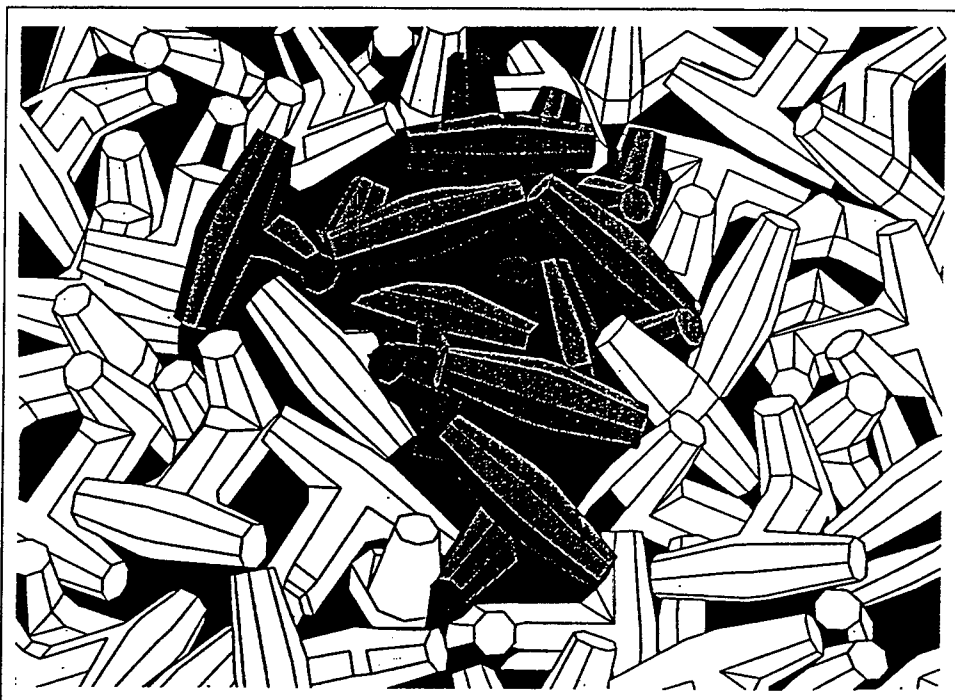

Figure 4. Illustration of Core-Loc and dolos armor matrix

Table 1 Model Material Sizes		
Component	Type	Weight
Primary Armor Type	Dolos	125.2 g (0.276 lb)
Repair Armor Type	Core-Loc	145.2 g (0.32 lb)
Underlayer	Stone	11 - 18 g (0.024-0.040 lb)
Core	Stone	5 - 11 g (0.011-0.024 lb)

Marsen Arsloe (TMA) shallow-water spectrum (Hughes 1984) for several wave periods.

Data acquisition

Water surface elevations were recorded by single-wire capacitance-type gauges. Data acquisition employed a sampling rate of 20 samples/sec. Wave data were stored on a MicroVax II minicomputer and analyzed using the Time Series Analysis computer program (Long and Ward 1987), which can execute several analysis operations. For the irregular waves generated, single channel frequency domain analysis was used to acquire peak period T_p , zero-moment

wave height H_{mo} , significant wave height H_s , maximum wave height H_{MAX} , and spectral density plots for each gauge. Unidirectional spectral density incident/ reflection analysis was used to determine the incident and reflected wave heights at each array.

Wave height calibration

The wave generator was placed such that the most severe waves impacted on the seaward face of the offshore breakwater head (Figure 5). Wave heights at the structure were calibrated without the breakwater in place for four wave periods, 1.41 sec, 1.84 sec, 2.4 sec, and 2.83 sec. Two sets of three-gauge arrays were positioned in the wave field. The first array, Array 1, was positioned 4.5 m (14.8 ft) from the wave generator, and the second array, Array 2, was positioned directly in the center of the offshore breakwater head section. The gauge arrays allowed calculation of incident and reflected wave heights by the methods of Goda and Suzuki (1976). Figure 6 shows a good example of depth-limited breaking where the offshore wave heights are much larger than the wave heights at the structure. Even though the offshore wave height continued to build with longer wave generator board stroke, the maximum significant wave height at the structure was 13.8 cm (5.43 in.). Figure 7 shows a much smaller differential between offshore and nearshore wave heights for the wave calibration time series with a peak period $T_p = 1.84$ sec. Figure 8 shows that for $T_p = 2.40$ sec, the shorter board strokes produced waves that would shoal to larger heights as they moved into shallow water,

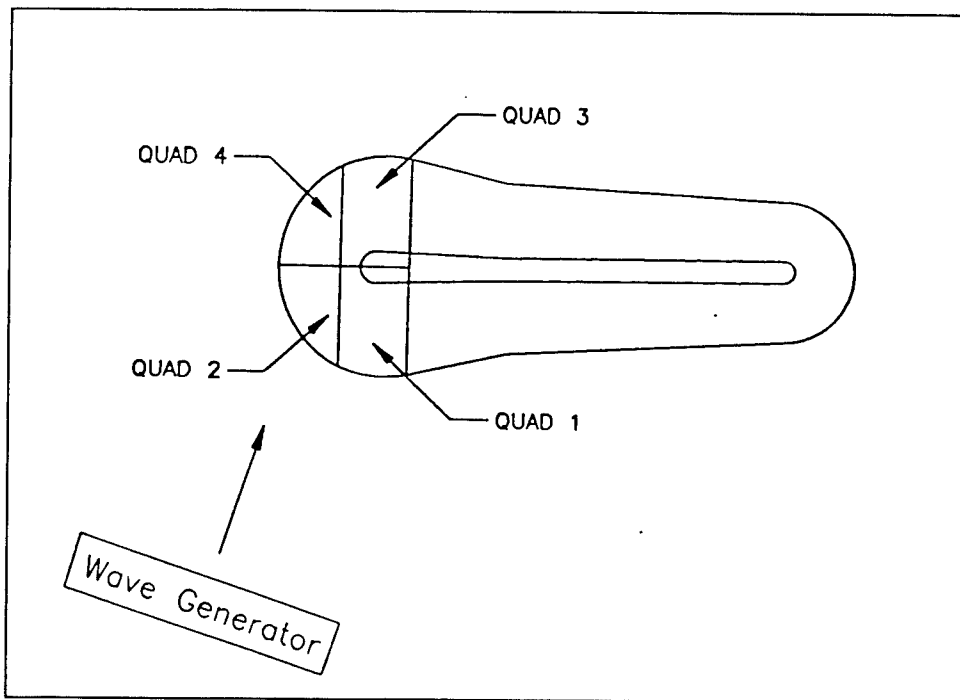

Figure 5. Plan view of offshore breakwater tested. Note position of wave maker and head section divided into four quadrants

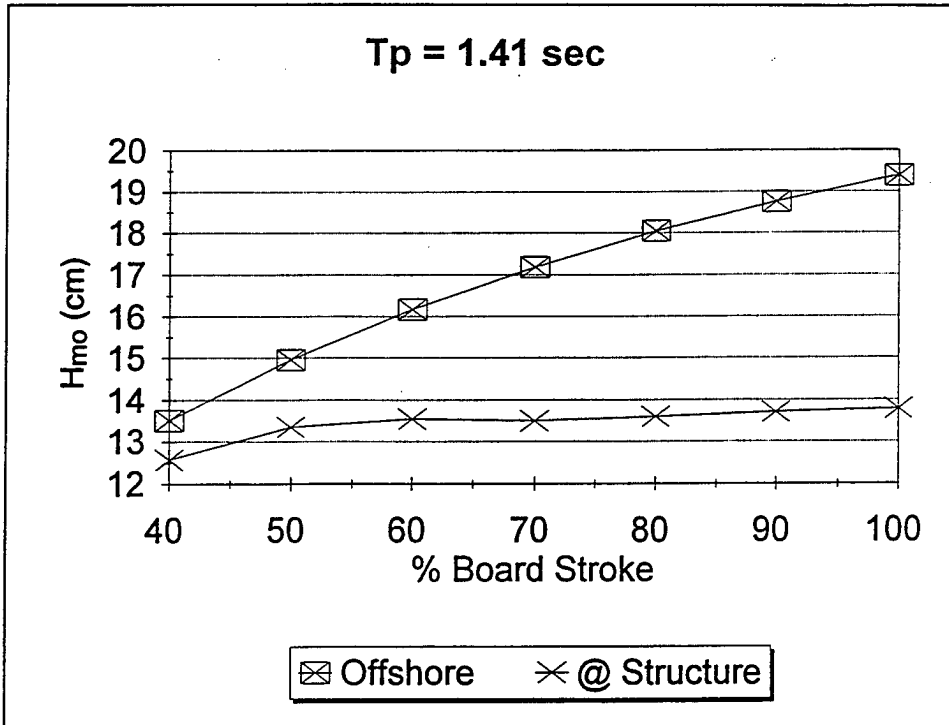

Figure 6. Wave calibration for $T_p = 1.41$ sec

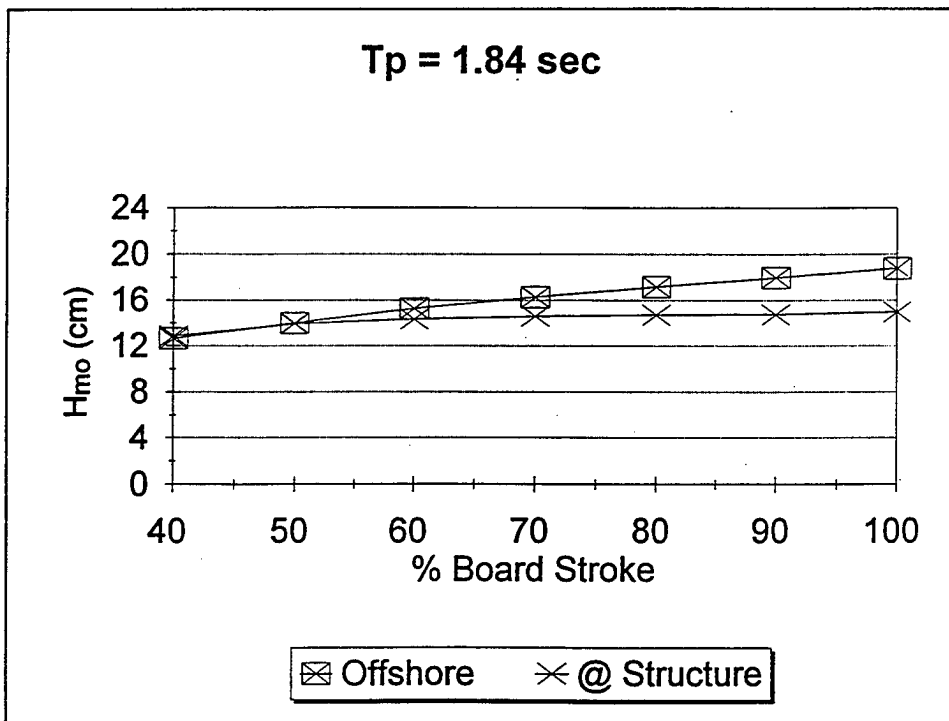

Figure 7. Wave calibration for $T_p = 1.84$ sec

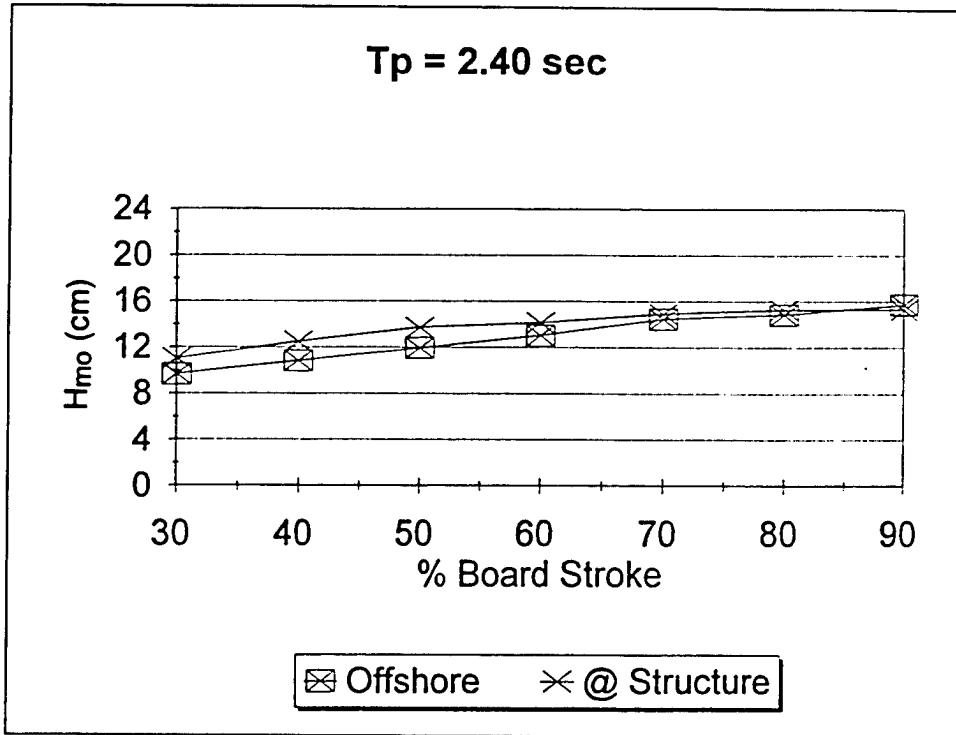

Figure 8. Wave calibration for $T_p = 2.40$ sec

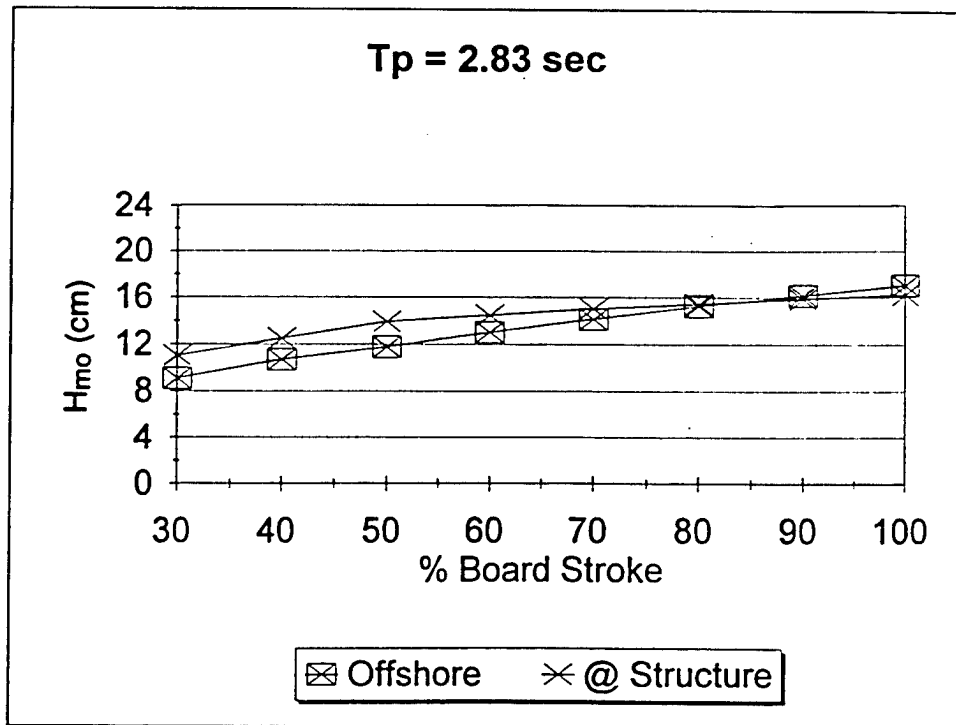

Figure 9. Wave calibration for $T_p = 2.83$ sec

but the limited zero moment wave height was $H_{mo} = 15.3$ cm (6.02 in.). Figure 9 shows this same trend for the $T_p = 2.83$ -sec wave calibration. The largest zero moment wave height was $H_{mo} = 15.4$ cm (6.06 in.). For these wave calibrations, the maximum zero moment breaking wave height in terms of water depth d was $H_b = 0.67d$.

Test Procedures

The experimental plan was to run increasingly energetic waves on the dolos armor until the damage progressed to imminent failure, then use the SRM to repair the slope with Core-Locs and repeat the test sequence. This was accomplished by running a specific test sequence consisting of 15-min wave packets, with each subsequent wave packet having an increased wave height (but same peak wave period). Each test sequence progressed from smaller no-damage waves to larger waves, eventually producing considerable damage to the dolos armor. Once a threshold level of damage (i.e., imminent catastrophic failure) was reached, the structure was repaired with Core-Locs. The repaired slope was then subjected to the same test sequence until damage reached a similar level as the original dolos slope or the repaired section remained stable. This procedure was repeated twice for each of the four peak wave periods.

First, the breakwater slope was armored with dolosse, paying strict attention to maintaining a constant packing density of $\phi = 0.83$. A photograph was taken of the slope prior to running waves. For the 125-g (0.28-lb) dolosse, this density requires approximately 590 dolosse per square meter of slope surface area. The test section on the offshore breakwater head had an area of 1 m^2 (10.76 ft^2). It was divided into four quadrants (Figure 5) of approximately the same size. The quadrants provided an indication of the region of damage, and also indicated any variation in the location of damage for the different wave periods.

The test sequence consisted of 15-min packets of irregular waves. The time series was produced from TMA spectra with a spectral peak enhancement parameter, $\gamma = 3.3$, where the peak period was held constant while the H_{mo} was increased for each subsequent packet.

The dolos size chosen for the repair tests was carefully selected such that the units would remain stable at the lower wave heights but become increasingly unstable as the wave heights increased. The stability of the armor units on the test section can be expressed in terms of the Hudson stability coefficient K_d determined from the equation

$$K_d = \frac{\gamma_a H^3}{W_a (S_a - 1)^3 \cot \alpha} \quad (5)$$

where

K_d = Hudson stability coefficient

γ_a = unit weight of the armor unit

H = wave height at the structure that causes no damage, i.e., wave height at which damage is less than or equal to 2 percent of the number of primary armor units placed on the respective breakwater slope

W_a = weight of an individual armor unit

S_a = specific gravity of the armor unit relative to the water at the structure ($S_a = \gamma_a/\gamma_w$, and γ_w = specific weight of water at the structure)

α = angle of the structure slope measured from horizontal

Hudson also expressed stability in the form of a stability number

$$N_S = (K_d \cot \alpha)^{1/3} \quad (6)$$

For the selected test sequences, N_S ranged from 2.3 (dolosse) to 2.7 (Core-Loc) ($K_d = 7.7$ to 13).

As each 15-min wave packet ran, the breakwater head was carefully watched for destabilizing dolos. Whenever an armor unit was rocking violently or displaced from its initial position, the unit was considered broken and removed from the slope. This assumption was made because the strength of the model unit is much greater than its prototype counterpart. Turk and Melby (1995) have shown that when dolosse are allowed to rock back and forth, they usually impact adjacent units. The internal stresses in the dolos far exceed the typical concrete strength, thus prototype units break when allowed to rock or displace. For some of the test runs, once a dolos displaced and was removed from the slope with tongs, two pieces of a broken unit were put in its place to determine their fate. For each 15-min packet, the number of displaced units was counted and initial positions were logged.

If the damage at the end of the packet was not excessive, the next-most-energetic wave packet was run. For each subsequent wave packet in the test sequence, the wave height was incrementally increased until the wave board stroke limitation (100 percent of the board stroke) was reached. The damage was allowed to progress through these 15-min wave packets of a given wave period until the researchers felt that the damage threshold was reached. If the damage levels were not considered extensive enough, the 100-percent board stroke wave packet was repeated until imminent catastrophic failure occurred (i.e., the structure was uncontrollably unraveling), or the structure simply remained stable. Catastrophic failure is defined as the point when a large

number of armor units are stripped from a given area, extending from the toe to the crown of the breakwater, and a significant amount of underlayer stone is stripped from the breakwater and the core is exposed.

At the end of a test sequence, photographs were taken, the damaged area of the breakwater armor was stripped of any remaining unconstrained dolosse, and the surface was prepared for placement of the Core-Loc repair units. Prior to the Core-Locs being placed, an estimate of the damaged area was made by measuring the exposed underlayer. Then individual Core-Locs were placed, one at a time with slings, to simulate a similar placement by crane in a prototype repair (Figure 10). The Core-Locs were counted as they were placed so a repair packing density could be calculated.

Once the Core-Locs were placed, photographs again were taken and the previous test sequence of identical 15-min wave packets was rerun on the repaired test section. As with the homogenous dolos armor layer, both dolosse and Core-Locs displaced during the test were removed from the hybrid Core-Loc/dolos layer until an equivalent amount of damage to the slope was manifested. Again photos were taken to show the extent of damage. Once the test was complete, the test section was completely rebuilt with dolosse and the next test sequence commenced.

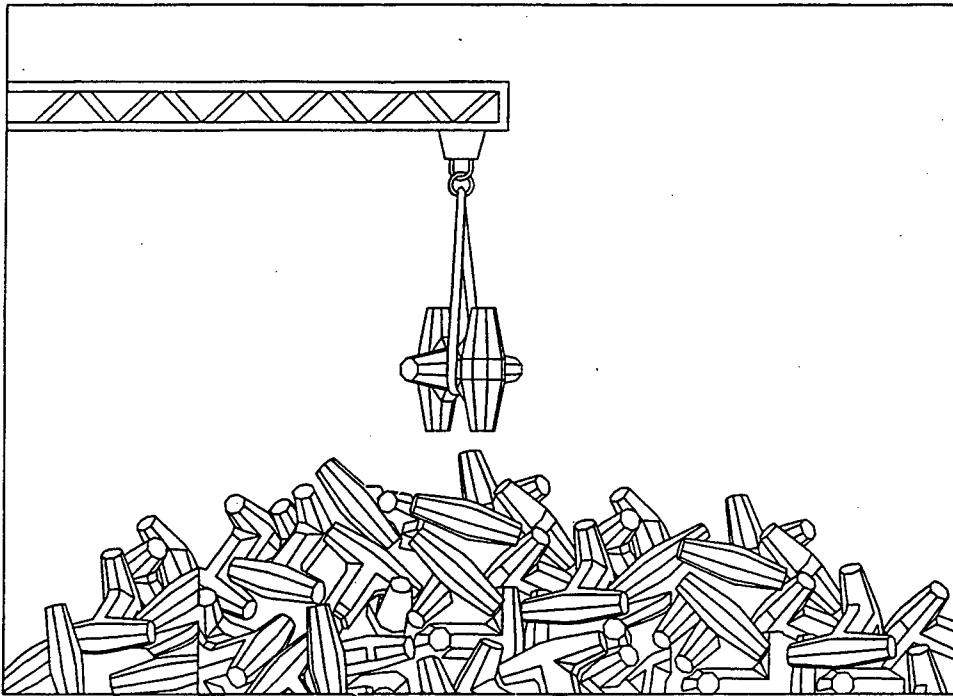

Figure 10. Illustration of Core-Loc suspended from crane by slings

3 Repair Test Results

The results of these repair tests come from eight test sequences, two repeated sequences of the same peak wave period. The results are shown in Tables 2-9. Photographs A1-A18 in Appendix A document examples of the damage progression from the test sequences.

Test Sequence 1 ($T_p = 1.41$ sec)

The first test sequence in the series, Test Sequence 1, was used to evaluate relatively short period, steep waves with a peak period of $T_p = 1.41$ sec. Significant wave heights ranged from 12.6 cm to 13.8 cm (4.96 to 5.43 in.). Results are shown in Table 2. Photo A1 shows the pretest, newly constructed dolos armoring. For this and all subsequent test sequences, whenever the dolos slope was built, units were placed at a packing density of $\phi = 0.83$. The extent of damage to the armor is shown in Photo A2.

During the test sequence, as the wave board stroke was increased for each wave packet, depth-limited breaking became apparent, with many of the larger waves breaking offshore of the breakwater head. As shown in Table 2, wave packets 1A-1D, armor displacement continued to progress with increase in wave height and/or time. By the end of wave packet 1E (1 hr 15 min), 24 dolosse were displaced. A decision was made to continue running waves on the structure. Wave packet 1F ended without further damage, but the slight increase in the wave energy of wave packet 1G displaced 22 additional dolosse. At the end of wave packet 1G, after exposing the dolos slope to waves for 1 hr 45 min, a total of 46 dolosse were displaced and removed from the slope. The majority of the exposed damage area was concentrated near the breakwater crown, with most of the damage in Quadrant 1 and some in Quadrant 3. It was observed that units began to displace from the lee side of the breakwater crown (Quadrant 3), which allowed units on the seaside (Quadrant 1) to loosen, displace, and eventually unravel. In addition to this concentrated damage, seven dolosse were also displaced from several locations in Quadrant 4.

Table 2
Results from Repair Test Sequence 1 ($T_p = 1.41$ sec)

Wave Packet No.	H_{mo} (cm) @ Toe	Number of Dolosse Displaced	Number of C-L Displaced	Location of Displaced Units				Cumulative Displaced Units
				Quad 1	Quad 2	Quad 3	Quad 4	
Complete New Dolos Armoring								
1A	12.6	6	N/A	-	-	5	1	6
1B	13.4	5	N/A	3	-	1	1	11
1C	13.6	3	N/A	3	-	-	-	14
1D	13.6	3	N/A	2	-	-	1	17
1E	13.6	7	N/A	3	-	-	4	24
1F	13.7	0	N/A	-	-	-	-	24
1G	13.8	22	N/A	14	-	4	4	46
Imminent failure - 46 dolosse displaced - Duration: 1 hr 45 min.								
Structure Repaired with 39 Core-Locs, Area of Repair = 800 cm ² (124 in. ²)								
1H	12.4	0	0	-	-	-	-	0
1I	12.6	1	0	-	-	1	-	1
1J	13.4	0	0	-	-	-	-	1
1K	13.6	0	0	-	-	-	-	1
1L	13.6	0	0	-	-	-	-	1
1M	13.6	0	0	-	-	-	-	1
1N	13.7	0	0	-	-	-	-	1
1O	13.8	3	0	-	-	3	-	4
1P	13.8	0	0	-	-	-	-	4
1Q	13.8	0	0	-	-	-	-	4
1R	13.8	0	0	-	-	-	-	4
1S	13.8	4	1	-	-	5	-	9
1T	13.8	0	0					
Test sequence terminated - structure remained stable - Duration: 3 hr 15 min.								

The damaged area was repaired with a total of 39 Core-Locs. Thirty-five Core-Locs were used to repair the 800-cm² (124-in.²) damaged area and four units were used in single unit spot repairs (Photo A3). The packing density for the Core-Loc was 0.71, slightly higher than the 0.58 packing density found during earlier tests of "all" Core-Loc armor slopes (Melby and Turk 1995c). Each unit was placed with a sling to simulate crane placement in a prototype condition.

Test Sequence 1 was continued, exposing the repaired breakwater head to wave packets 1H-1T (Table 2). By the end of wave packet 1T, after 3 hr 15 min of wave exposure, eight dolosse and one Core-Loc were displaced from the slope (Photo A4). Test Sequence 1 was then terminated as the structure was deemed stable.

Test Sequence 2 ($T_p = 1.41$ sec)

Test Sequence 2 was a repeat of Test Sequence 1 and is summarized in Table 3. The initial dolos armoring was subjected to five, 15-min wave packets (wave packets 2A-2E) with zero moment wave heights ranging from 12.6 to 13.6 cm (5.35 in.) for a total duration of 1 hr 15 min. At the end of wave packet 2E, 29 dolosse had displaced, leaving an area of exposed under-layer layer of approximately 500 cm² (77.50 in.). The majority of damage was just above the still-water level in Quadrant 1, and extended over the crown to Quadrant 3. The damaged area was repaired with 23 Core-Locs, 21 of which were placed in the damaged area and two in separate locations in Quadrant 4. The Core-Loc packing density was found to be 0.68. The sequence continued with the incremented wave time series reinitialized, with zero moment wave heights ranging from 12.6 to 13.8 cm (4.96 to 13.80 in.). At the end of wave packet 2T, after 3 hr 15 min of wave attack, only one dolos had displaced from the slope. No Core-Locs had displaced. The structure was deemed stable and the test sequence was terminated.

Table 3
Results from Repair Test Sequence 2 ($T_p = 1.41$ sec)

Wave Packet No.	H_{mo} (cm) @ Toe	Number of Dolosse Displaced	Number of C-L Displaced	Location of Displaced Units				Total Displaced Units
				Quad 1	Quad 2	Quad 3	Quad 4	
Complete New Dolos Armoring								
2A	12.6	0	N/A	-	-	-	-	0
2B	13.4	0	N/A	-	-	-	-	0
2C	13.6	8	N/A	3	-	2	3	8
2D	13.6	14	N/A	9	-	3	2	22
2E	13.6	7	N/A	7	-	-	-	29
Imminent failure - run terminated - 29 dolosse displaced - Duration: 1 hr 15 min.								
Structure Repaired with 23 Core-Locs, Area of Repair = 500 cm ² (77.5 in. ²)								
2F	12.6	0	0	-	-	-	-	0
2G	13.4	0	0	-	-	-	-	0
2H	13.6	1	0	-	1	-	-	1
2I	13.6	0	0	-	-	-	-	1
2J	13.6	0	0	-	-	-	-	1
2K	13.7	0	0	-	-	-	-	1
2L	13.8	0	0	-	-	-	-	1
2M	13.8	0	0	-	-	-	-	1
2N	13.8	0	0	-	-	-	-	1
2O	13.8	0	0	-	-	-	-	1
2P	13.8	0	0	-	-	-	-	1
2S	13.8	0	0	-	-	-	-	1
2T	13.8	0	0	-	-	-	-	1
Test sequence terminated - structure remained stable - Duration: 3 hr 15 min.								

Test Sequence 3 ($T_p = 1.84$ sec)

Test Sequence 3 was unique in that the structure was repaired twice (Table 4), once with Core-Locs and once with dolosse. The peak period for this sequence was $T_p = 1.84$ sec and zero moment wave heights ranged from 12.6 to 15 cm (4.96 to 5.91 in.). These wave heights correspond to Hudson stability numbers $N_s = 2.6$ to 3.1 ($K_d = 11.6 - 19.6$). The test started with the initial dolos armoring (Photo A5), which failed after a 2-hr duration. By the end of wave packet 3H, 53 dolosse were displaced from the slope.

Table 4								
Results from Repair Test Sequence 3 ($T_p = 1.84$ sec)								
Wave Packet No.	H_{mo} (cm) @ Toe	Number of Dolosse Displaced	Number of C-L Displaced	Location of Displaced Units				Total Displaced Units
				Quad 1	Quad 2	Quad 3	Quad 4	
Complete New Dolos Armoring								
3A	12.6	0	N/A	-	-	-	-	0
3B	12.9	2	N/A	1	-	-	1	2
3C	14.0	3	N/A	2	-	-	1	5
3D	14.3	10	N/A	3	2	2	3	15
3E	14.6	3	N/A	2	-	-	1	18
3F	14.7	6	N/A	3	-	1	2	24
3G	14.8	4	N/A	-	-	2	2	28
3H	15.0	25	N/A	5	5	8	7	53
Imminent failure - 53 dolosse displaced - Duration: 2 hr 0 min.								
Structure Repaired with 34 Core-Locs, Area of Repair = 830 cm ² (128.65 in. ²). (Additional 30 Core-Locs Placed in Single Unit Spot Repair)								
3I	12.6	0	0	-	-	-	-	0
3J	12.9	0	0	-	-	-	-	0
3K	14.0	0	0	-	-	-	-	0
3L	14.3	0	0	-	-	-	-	0
3M	14.6	0	0	-	-	-	-	0
3N	14.7	0	4	-	-	2	2	4
3O	14.8	1	0	-	1	-	-	5
3P	15.0	16	7	4	6	7	5	28
Test sequence terminated - imminent failure - 17 dolosse and 11 Core-Locs displaced - Duration: 2 hr 0 min.								
Special Test - Structure Repaired with 58 Dolosse, Area of Repair = 850 cm ² (131.75 in. ²). Additional 35 Dolosse Replaced Core-Locs in Single-Unit Spot Repair								
3Q	12.6	5	N/A	4	1	-	-	5
3R	12.9	4	N/A	2	-	2	-	9
3S	14.0	2	N/A	-	-	2	-	11
3T	14.3	4	N/A	-	-	4	-	15
3U	14.6	8	N/A	-	2	3	3	23
3V	14.7	14	N/A	-	12	2	-	37
3W	14.8	34	N/A	5	10	8	11	71
Test sequence terminated - imminent failure - 71 dolosse displaced, 46 repair units and 26 original units - Duration: 1 hr 45 min.								

During this portion of the test sequence, whenever a dolos was displaced and removed from the slope, two broken pieces of dolos were put in the removed dolos' place. Approximately 100 pieces of broken dolos replaced the 53 dislodged dolosse. By the end of the 2 hr, only 10 pieces remained on the slope. The rest of the pieces were swept off the breakwater and ended up shoreward of the structure. In Photo A6, the damaged area is centered at the confluence of Quadrants 1-4, and several of the broken pieces of dolosse remaining on the slope can be seen.

The 830 cm² (128.65 in.²) of damage was repaired with Core-Locs, 34 used as a patch (packing density of 0.67), and 30 additional units placed in single unit spot repairs (Photo A7). Most of the 30 units were placed outside the test section, on the lee of the structure. They were used as a precautionary measure against premature failure of the non-test-section trunk and also for observing how the Core-Locs performed after simply being placed in a small hole. The wave packets were rerun on the Core-Loc repair and this time the structure was in imminent danger of failing after 2 hr at the end of wave packet 3P (Photo A8). The performance of the repair was similar to the original dolos construction. While only 11 Core-Locs and 17 dolosse displaced, had the structure been exposed to another wave packet, it probably would have degraded to a similar state as a dolos-only structure.

Instead of terminating the test sequence, a special check test was performed to see how dolosse performed as a repair unit for dolosse. After the Core-Loc repair was sufficiently damaged by wave packet 3P, the Core-Locs were removed and the 850-cm² (131.75 in.²) damage area was repaired with 58 of the same dolosse as the ones used originally. In addition, 35 dolosse were used to replace the Core-Locs from the single unit spot repair. Photo A9 shows the structure with all the repair dolosse in place. These dolosse were placed tightly with slings and the packing density was calculated to be 0.99, 18 percent higher than a typical 0.83 packing density found on new dolos structures. Even at the higher packing density at the end of wave packet 3W (1 hr 45 min), 71 of the dolosse, 45 of the repair units, and 26 of the original units were displaced from the slope (Photo A10). The dolos repair was not as stable as the original dolos construction or the Core-Loc repair.

Test Sequence 4 ($T_p = 1.84$ sec)

Test Sequence 4 was a repeat of the $T_p = 1.84$ -sec wave packets. Results are shown in Table 5. The dolos armor was tested for a duration of 1 hr 15 min. During wave packets 4A-4E, with zero moment wave heights from 12.9 to 14.7 cm (5.08 to 5.79 in.), 25 dolos had displaced. Most of the units came off of Quadrants 2 and 4, exposing a damage area of 440 cm² (68.20 in.²). For this repair, 27 Core-Locs were used, 19 for the patch placed at a higher packing density of 0.70, and 8 Core-Locs for single unit repairs. At the end of 2 hr 30 min (wave packets 4F-4O), 44 dolosse and

Table 5
Results from Repair Test Sequence 4 ($T_p = 1.84$ sec)

Wave Packet No.	H_{mo} (cm) @ Toe	Number of Dolosse Displaced	Number of C-L Displaced	Location of Displaced Units				Total Displaced Units
				Quad 1	Quad 2	Quad 3	Quad 4	
Complete New Dolos Armoring								
4A	12.9	1	N/A	-	-	-	1	1
4B	14.0	1	N/A	-	-	-	1	2
4C	14.3	6	N/A	-	1	1	4	8
4D	14.6	4	N/A	2	-	1	1	12
4E	14.7	13	N/A	-	2	-	11	25
Imminent failure - 25 dolosse displaced - Duration: 1 hr 15 min.								
Structure Repaired with 27 Core-Locs, Area of Repair = 440 cm ² (68.20 in. ²)								
4F	12.9	0	0	-	-	-	-	0
4G	14.0	0	1	-	-	-	1	1
4H	14.3	4	0	1	3	-	-	5
4I	14.6	1	0	-	1	-	-	6
4J	14.7	4	2	-	2	2	2	12
4K	14.8	4	1	-	2	1	2	17
4L	15.0	8	0	-	8	-	-	25
4M	15.0	5	1	-	2	3	1	31
4N	15.0	8	0	-	1	4	3	39
4O	15.0	10	12	-	10	2	10	51
Test sequence terminated - imminent failure - 44 dolosse and 17 Core-Locs displaced - Duration: 2 hr 30 min.								

17 Core-Locs were displaced. Like the dolosse, the majority of these units displaced from Quadrants 2 and 4.

With the higher packing density, the Core-Locs appeared to remain interlocked longer as the patched area widened and thinned. This thinning was due to dolos dislodging adjacent to the Core-Loc patch. As the Core-Locs filled the voids left by the displaced dolosse, the patch started to loosen and the Core-Locs destabilized as they started migrating downslope. The higher packing density provided more units on slope to "feed" these voids. For Test Sequence 4, the Core-Loc patch lasted longer than that of Test Sequence 3.

Test Sequence 5 ($T_p = 2.4$ sec)

Test Sequence 5 used wave packets with $T_p = 2.4$ sec and zero moment wave heights from 11.0 to 15.3 cm (4.33 to 6.02 in.) (Table 6). Photo A11 shows the new dolos test section. For this longer period wave, the damage progressed quickly during wave packet 5C (13.7-cm wave). The structure experienced zero moment damage after only 45 min of waves (wave packets 5A-5C). Photo A12 shows the damaged area in Quadrants 1 and 3.

Table 6								
Results from Repair Test Sequence 5 ($T_p = 2.40$ sec)								
Wave Packet No.	H_{mo} (cm) @ Toe	Number of Dolosse Displaced	Number of C-L Displaced	Location of Displaced Units				Total Displaced Units
				Quad 1	Quad 2	Quad 3	Quad 4	
Complete New Dolos Armoring								
5A	11.0	4	N/A	2	-	-	2	4
5B	12.5	8	N/A	5	-	3	-	12
5C	13.7	60	N/A	40	-	15	5	72
Imminent catastrophic failure - 72 dolosse displaced - Duration: 0 hr 45 min.								
Structure Repaired with 60 Core-Locs, Area of Repair = 1,400 cm ² (217 in. ²)								
5D	11.0	2	0	-	-	1	1	2
5E	12.5	2	0	1	1	-	-	4
5F	13.7	1	0	1	-	-	-	5
5G	14.1	7	2	3	4	1	1	14
5H	15.0	2	0	-	-	2	-	16
5I	15.3	9	1	2	5	2	1	26
5J	15.3	18	35	18	30	4	1	79
Test sequence terminated 11 min into packet 5J - imminent failure - 41 dolosse and 38 Core-Locs displaced - Duration: 1 hr 41 min.								

The area was estimated to be 1,400 cm² (217 in.²). In the photo, several of the 72 dolosse displaced can be seen on the lee side of the structure. These units were washed off the head during some of the larger waves in wave packet 5C. The structure was repaired with 60 Core-Locs (Photo A13) using a packing density of 0.70.

The Core-Loc repair portion of Test Sequence 5 was terminated 11 min into wave packet 5J. By this time, the structure had experienced catastrophic failure after a total wave attack duration of 1 hr 41 min. The waves displaced 79 units, 41 dolosse, and 38 Core-Locs, cutting a diagonal swath of damage (Photo A14) extending from the toe in Quadrant 2 to over the crown into Quadrant 4. Armor units, underlayer stone, and apron stone were all dislodged during the wave attack.

Test Sequence 6 ($T_p = 2.4$ sec)

Test Sequence 6 (Table 7) was a repeat of Test Sequence 5. The break-water head was reconstructed with dolosse and the sequence initiated. After 45 min of wave action (wave packets 6A-6C), 26 dolosse were displaced, the majority coming from Quadrant 2. The damaged area was 500 cm² (77.50 in.²). The structure was repaired with 22 Core-Locs placed at a packing density of 0.72. Wave packets 6D-6H (1 hr 15 min) were run before the sequence was terminated. The damage mostly occurred in Quadrant 2 and resulted from 28 dolosse and 14 Core-Locs being displaced.

Table 7								
Results from Repair Test Sequence 6 ($T_p = 2.40$ sec)								
Wave Packet No.	H_{mo} (cm) @ Toe	Number of Dolosse Displaced	Number of C-L Displaced	Location of Displaced Units				Total Displaced Units
				Quad 1	Quad 2	Quad 3	Quad 4	
Complete New Dolos Armoring								
6A	13.7	0	N/A	-	-	-	-	0
6B	14.1	13	N/A	-	4	4	5	13
6C	15.0	13	N/A	1	10	1	1	26
Imminent failure - 26 dolosse displaced - Duration: 0 hr 45 min.								
Structure Repaired with 22 Core-Locs, Area of Repair = 500 cm ² (77.5 in. ²)								
6D	13.7	0	0	-	-	-	-	0
6E	14.1	2	0	-	2	-	-	2
6F	15.0	4	0	-	-	4	-	6
6G	15.3	5	0	-	2	3	-	11
6H	15.3	17	14	-	18	5	8	42
Test sequence terminated - imminent failure - 28 dolosse and 14 Core-Locs displaced - Duration: 1 hr 15 min.								

Test Sequence 7 ($T_p = 2.83$ sec)

Test Sequence 7 had the longest wave periods used in the investigation, $T_p = 2.83$ sec, and zero moment wave heights ranging from 11.1 to 15.4 cm (4.37 to 6.06 in.). Results are shown in Table 8. Photo A15 shows the new dolos armoring. During the first part of the sequence, through wave packet 7C, broken dolos pieces were used to replace dolosse displaced from the slope. The dolos slope was in danger of imminent failure after 45 min of waves (wave packets 7A-7C). Most damage occurred during wave packet 7C, in which $H_{mo} = 14$ cm (5.51 in.). Many of the pieces of broken dolosse moved from their initial location in Quadrants 1 and 3, and were scattered over the breakwater head and in the lee of the structure (Photo A16). The 51 dolosse displaced from 900 cm² (139.50 in.²) of damaged area were replaced with 40 Core-Locs, and an additional 5 units were used for single unit repairs (Photo A17). The packing density was calculated to be 0.72. The repaired structure withstood wave attack for 1 hr 30 min and significant wave heights up to 15.4 cm (6.06 in.). With Test Sequence 7 ending with wave packet 7I, the majority of the damage occurred in Quadrants 1 and 3, with 33 dolosse and 10 Core-Locs displaced (Photo A18).

Test Sequence 8 ($T_p = 2.83$ sec)

The results of Test Sequence 8, a repeat of Test Sequence 7, are shown in Table 9. The new dolos slope withstood wave attack for 1 hr, with zero moment wave heights to 14.5 cm (5.71 in.). Thirty-eight dolosse displaced from an area of 750 cm² (116.25 in.²). For the repair, 35 Core-Locs were

Table 8								
Results from Repair Test Sequence 7 ($T_p = 2.83$ sec)								
Wave Packet No.	H_{mo} (cm) @ Toe	Number of Dolosse Displaced	Number of C-L Displaced	Location of Displaced Units				Total Displaced Units
				Quad 1	Quad 2	Quad 3	Quad 4	
Complete New Dolos Armoring								
7A	11.1	0	N/A	-	-	-	-	0
7B	12.5	13	N/A	8	-	5	-	13
7C	14.0	38	N/A	32	-	6	-	51
Imminent failure - 51 dolosse displaced - Duration: 0 hr 45 min.								
Structure Repaired with 45 Core-Locs, Area of Repair = 900 cm ² (139.50 in. ²)								
7D	11.1	0	0	-	-	-	-	0
7E	12.5	3	0	-	2	1	-	3
7F	14.0	2	0	-	2	-	-	5
7G	14.5	8	2	-	4	6	-	15
7H	15.1	15	0	4	0	9	2	30
7I	15.4	5	8	-	8	5	-	43
Test sequence terminated - imminent failure - 33 dolosse and 10 Core-Locs displaced - Duration: 1 hr 30 min.								

Table 9								
Results from Repair Test Sequence 8 ($T_p = 2.83$ sec)								
Wave Packet No.	H_{mo} (cm) @ Toe	Number of Dolosse Displaced	Number of C-L Displaced	Location of Displaced Units				Total Displaced Units
				Quad 1	Quad 2	Quad 3	Quad 4	
Complete New Dolos Armoring								
8A	11.1	0	N/A	-	-	-	-	0
8B	12.5	5	N/A	-	2	2	1	5
8C	14.0	9	N/A	-	1	6	2	14
8D	14.5	24	N/A	-	10	7	7	38
Imminent failure - 38 dolosse displaced - Duration: 1 hr 0 min.								
Structure Repaired with 40 Core-Locs, Area of Repair = 750 cm ² (116.25 in. ²)								
8E	11.1	1	2	-	-	2	1	3
8F	12.5	2	3	-	2	-	3	8
8G	14.0	3	3	-	3	1	2	14
8H	14.5	5	13	-	10	4	4	32
Test sequence terminated - imminent failure - 11 dolosse and 21 Core-Locs displaced - Duration: 1 hr 0 min.								

tightly placed at a packing density of 0.76. For single unit spot repairs, five more Core-Locs were used. The repaired structure also was subject to 1 hr of wave attack, after which 11 dolosse and 21 Core-Locs were displaced from the slope.

4 Discussion of Results

In six of the eight test sequences conducted, the Core-Loc repair units outperformed the original dolos armoring used on the breakwater. For the other two sequences, the Core-Loc repair and the original dolos armor withstood the same duration and magnitude of wave attack. Figure 11 compares the duration of wave attack the original dolos armor withstood to the Core-Loc-repaired structure for the eight test sequences.

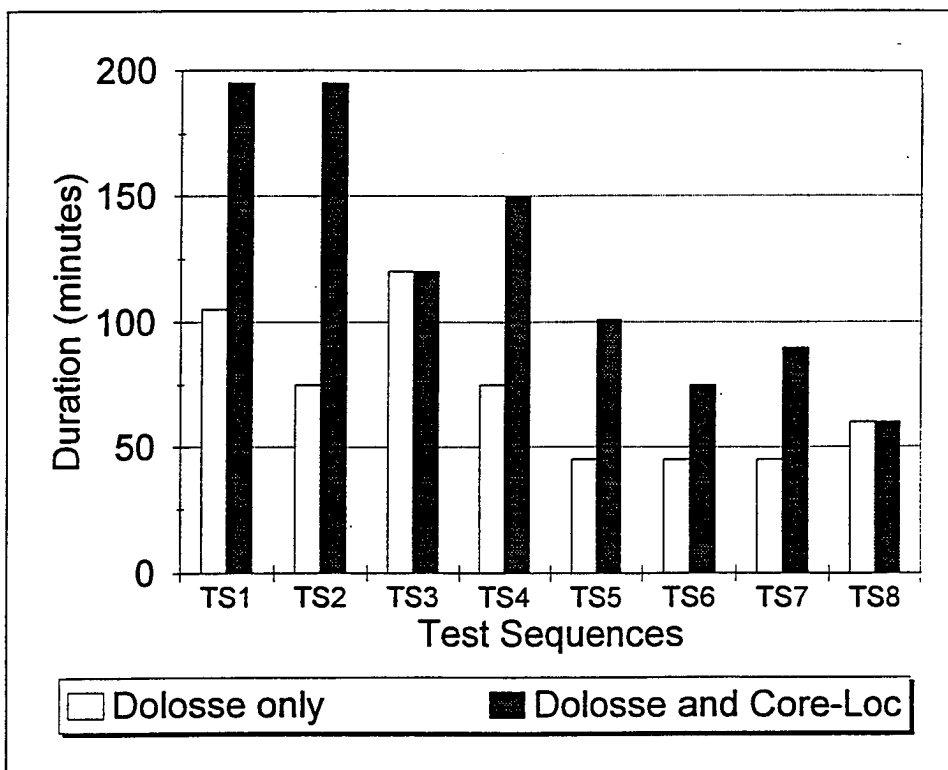

Figure 11. Duration of wave attack the original dolos armor withstood compared to the Core-Loc-repaired structure for Test Sequences 1-8

It was difficult to observe the evolution of the slope profile during the test sequences because overtopping waves often obscured the view. In many cases, at the end of the more severe wave packets, it was obvious that some of the armor units had undergone an imperceptible shift in position during prolonged wave attack. Sometimes the Core-Loc would loosen as a result of dolosse adjacent to the repair area becoming unstable. These surrounding dolosse would displace or migrate slowly downslope away from the Core-Loc patch, allowing the Core-Locs to loosen. For the longer period waves that tended to repeatedly overtop the structure, dolosse would often displace off the backside of the structure causing the slope to steepen. Once this happened, failure could almost be predicted to occur. With continued wave attack, the steep dolos slope would begin to slump and unconstrain the Core-Locs. The Core-Locs would then loosen and begin to displace. Often, the instability of the Core-Loc patch was a function of the instability of the dolosse at the transition area at the perimeter of the patch.

One of the more difficult tasks was determination of the damaged area on the slope. The mean Core-Loc repair packing density ϕ_r for the eight sequences was $\phi_r = 0.71$. This value is higher than the packing density for Core-Loc, found through past controlled investigations to range from $\phi = 0.54$ to $\phi = 0.62$. In the past investigations, the slope area is well-defined. In these repair tests, exact slope area to be repaired could only be estimated using a crude grid system. The "hole" often had irregular edges and was located on the curvilinear head section. The Core-Locs were placed by slings as in previous experiments and the packing on the repair patch appeared similar to that used in the past. But in determining the packing density based on the number of Core-Locs placed and the estimated area of repair, the repair packing density was consistently higher than that found in newly constructed, Core-Loc-only physical models (Melby and Turk 1995c).

In observing damage progression during the tests, it was found that wave packets with longer wave periods caused instability in a much shorter duration than those with shorter wave periods. The zero moment wave heights for all the packets did not vary much (from 12.4 cm to 15.3 cm (from 4.88 in. to 6.02 in.)), but for $T_p = 2.4$ sec or greater, the slope began to unravel much quicker. Most of the larger waves would break on the foreshore slope regardless of wave period, but the longer period waves contained much more momentum. They would overtop the structure and cause instability. It was interesting to note that the location of the major damage always manifested itself on or about the still-water level on the seaward side of the breakwater head, normal to the angle of wave attack. In one case, Test Sequence 5 ($T_p = 2.4$ sec), severe wave attack caused the armoring to disintegrate from the toe to the crown. Prior to the tests it was anticipated that backside instability would be observed. But at the single water depth tested for the breakwater configuration and wave parameters, only minor damage occurred on the backside of the breakwater.

5 Summary and Conclusions

Summary

These preliminary three-dimensional repair tests show that Core-Loc can be successfully used for the repair of dolos-armed breakwaters. Eight test sequences were conducted with peak wave periods ranging from $T_p = 1.41$ sec to 2.83 sec. Zero moment wave heights ranged from 11.0 cm to 15.3 cm (4.33 in. to 6.02 in.). One water depth (23 cm (9.06 in.)), one weight of Core-Loc (145 g (0.32 lb)) armor units, and one weight of dolos (125 g (0.28 lb)) were used for the tests. The ratio of Core-Loc fluke length C_{CL} to dolos fluke length C_{DO} was $C_{CL}/C_{DO} = 0.93$. The repair method used throughout the tests was the spot repair method. The V-notch method was not used for these tests, but its use is planned in the future.

A breakwater head section with a 1V:1.5H structure slope was first armored with dolosse. The structure then was subject to a series of 15-min wave packets of sequentially increasing wave height. As the structure began to degrade, dolosse displaced from their initial position were mechanically removed from the slope. Once the dolos armor layer reached a point of imminent failure, the waves were stopped and the structure was repaired with Core-Loc. The same series of wave packets was run on the rehabilitated structure until a level of damage similar to the dolos-only armor was reached. Results before and after repair were compared. The Core-Loc repair was at least as good, and in general, more hydraulically stable than the original dolos structure.

Conclusions

For the tests conducted, zero moment wave heights ranged from 11.0 cm to 15.3 cm (4.33 in. to 6.02 in.). The hydraulic stability of the dolosse and Core-Loc expressed in terms of Hudson stability number ranged from $N_s = 2.3$ (dolosse) to 2.7 (Core-Loc) ($K_d = 7.7$ to 13). Most of the dolos-armed structures in the United States fall within this range of hydraulic stability (Melby and Turk 1995a), and some have required repairs. In most cases, the repairs have been made with dolosse of the same size as the original armor. Slender dolosse of inadequate strength have, by the nature of their flexural

structural response, a predisposition toward breakage under impact loading (Melby and Turk 1994). Finite Element Analysis, comparing the structural response of dolosse and Core-Loc, shows the maximum tensile stress in Core-Loc to be 60 percent that of dolosse (Melby and Turk 1995c). For future repairs of dolos slopes, Core-Locs, with their superior structural strength characteristics and hydraulic stability, may prove to provide lasting repairs for existing dolos-armored slopes.

During the tests, it was observed that the onset of armor unit hydraulic instability occurred much sooner in the test series for longer period waves ($T_p = 2.40$ and 2.83 sec). This was the same conclusion reached by Carver, Herrington, and Wright (1987), where the stability of dolos-armored rubble-mound breakwater heads was investigated. Even though zero moment incident wave heights reached depth-limited breaking, regardless of wave period tested, the longer period waves contain much more momentum and tended to easily overtop the structure. These overtopping waves were much more destructive than the shorter period waves which expended much of their energy on the foreshore slope.

The area of the breakwater head that repeatedly sustained the most damage was the seaside slope facing the direction of wave attack. For the four peak wave periods tested, the damage always started with instability in the armor layer at or slightly above the still-water level. As units displaced, the armor layer would shift and loosen. Adjacent armor units would lose interlocking with the matrix as they migrated toward the hole left by the displaced units. These units then would displace, and the matrix would begin to unravel. When a dolos displaced and was replaced with broken pieces, these pieces would rarely remain where they were put. Most of the broken pieces would end up off the structure in the lee of the breakwater. From these tests, there was no indication that broken pieces either aid or detract from the integrity of the armor layer. It should be kept in mind, however, that the fate of broken pieces in the prototype is not well understood, and they may act as projectiles causing breakage of other units.

Markle and Davidson (1983) investigated the effects of dolos breakage on the stability of rubble-mound breakwater trunks when subjected to breaking and nonbreaking waves. They concluded that if uniform breakage does not exceed 15 percent in the top layer, 15 percent in the bottom layer, a total of 7.5 percent breakage in both layers, or a cluster of five broken dolosse, the overall stability of the dolos armor layer will be similar to an armor layer with no breakage. In the three-dimensional repair tests reported herein, as a general observation, once a cluster of about 25 dolosse was removed from the slope, damage progressed very quickly. Catastrophic failure was usually imminent. Questions often arise as to what damage level is appropriate to mobilize for repairs. It is the authors' opinion that if a cluster of five broken dolosse is observed, the damaged area should be closely monitored for accelerated damage rates and plans should be made for repair. It may take several years to acquire funds and mobilize for a repair. If the damage is allowed to progress to a level approaching 25 broken dolosse before making a decision to

repair, an inclement season may severely damage the breakwater, resulting in exorbitant rehabilitation costs.

From this preliminary test series, one lesson learned was that when a breakwater slope is repaired, the patch is only as stable as the surrounding original armor matrix. In many cases, a particular reach or location on a breakwater is exposed to wave focusing effects where the wave attack is more severe than on the rest of the breakwater. The breakwater should be carefully inspected to determine if there is any evidence of dolos movement about the perimeter of the damaged area. If so, and if a repair is to be initiated using Core-Locs to repair a marginally stable dolosse slope, the repair area should be expanded to cover the entire unstable region. If economics dictate that only the damaged area can be repaired, extra Core-Loc repair units should be cast for placement at a later date if the patch is observed to loosen.

References

- Carver, R. D., Herrington, C. R., and Wright, B. J. (1987). "Stability of stone- and dolos-armed rubble-mound breakwater heads subjected to nonbreaking waves with no overtopping," Technical Report CERC-87-18, U.S. Army Engineer Waterways Experiment Station, Vicksburg, MS.
- Goda, T., and Suzuki, Y. (1976). "Estimation of incident and reflected waves in random wave experiments." *Proc. of the 15th Coastal Engrg. Conf.*, Honolulu, HI, 828-845.
- Hudson, R. Y. (1975). "Reliability of rubble-mound breakwater stability models," Miscellaneous Paper H-75-5, U.S. Army Engineer Waterways Experiment Station, Vicksburg, MS.
- Hughes, S. A. (1984). "The TMA shallow-water spectrum description and applications," Technical Report CERC-84-7, U.S. Army Engineer Waterways Experiment Station, Vicksburg, MS.
- Keulegan, G. H. (1973). "Wave transmission through rock structures; hydraulic model investigation," Research Report H-73-1, U.S. Army Engineer Waterways Experiment Station, Vicksburg, MS.
- Long, C. E., and Ward, D. L. (1987). "Time series analysis," unpublished computer program, U.S. Army Engineer Waterways Experiment Station, Vicksburg, MS.
- Markle, D. G., and Davidson, D. D. (1983). "Effects of dolos breakage on the stability of rubble-mound breakwater trunks subjected to breaking and nonbreaking waves with no overtopping," Technical Report CERC-83-4, U.S. Army Engineer Waterways Experiment Station, Vicksburg, MS.
- Melby, J. A., and Turk, G. F. (1994). "Scale and modeling effects in concrete armor experiments." *Proceedings, 1st Int. Conf. on Role of L.S. Exp in Coas. Res.* American Society of Civil Engineers, New York.

- Melby, J. A., and Turk, G. F. (1995a). "Concrete armor performance in light of recent research results." *ASCE/WPCO Sem. on Case Histories of Design, Constr., and Maint. of Rubble Mound Struc.* American Society of Civil Engineers, New York.
- _____. (1995b). "The CORE-LOC: Optimized concrete armor." *Proc. 24th Int'l Conf. on Coastal Engineering, Kobe, Japan.* American Society of Civil Engineers, New York.
- _____. (1995c). "CORE-LOC concrete armor units," in preparation, U.S. Army Engineer Waterways Experiment Station, Vicksburg, MS.
- Shore protection manual.* (1984). 4th ed., 2 Vol, U.S. Army Engineer Waterways Experiment Station, U.S. Government Printing Office, Washington, DC.
- Smith, E. R., Cole, J., Bonnigut, T., and Hennington, L. (1995). "Stability tests of proposed breakwater at Noyo, California." *ASCE/WPCO Sem. on Case Histories of Design, Constr., and Maint. of Rubble Mound Struc.* American Society of Civil Engineers, New York.
- Stevens, J. C., Bardsley, C. E., Lane, E. W., and Straub, L. G. (1942). "Hydraulic models." *Manuals on engineering practice No. 25.* American Society of Civil Engineers, New York.
- Turk, G. F., and Melby, J. A. (1995). "The large scale dolos flume study." *Proc. 24th Int'l Conf. on Coastal Engineering, Kobe, Japan.* American Society of Civil Engineers, New York.

Appendix A

Photographs of 3-D Repair Tests



Photo A1. Freshly built dolosse armoring for Test Sequence 1 (TS1),
 $T_p = 1.41$ sec



Photo A2. TS1, damage to dolos armoring after 1 hr 15 min duration



Photo A3. TS1, Core-Loc repair of dolosse armor

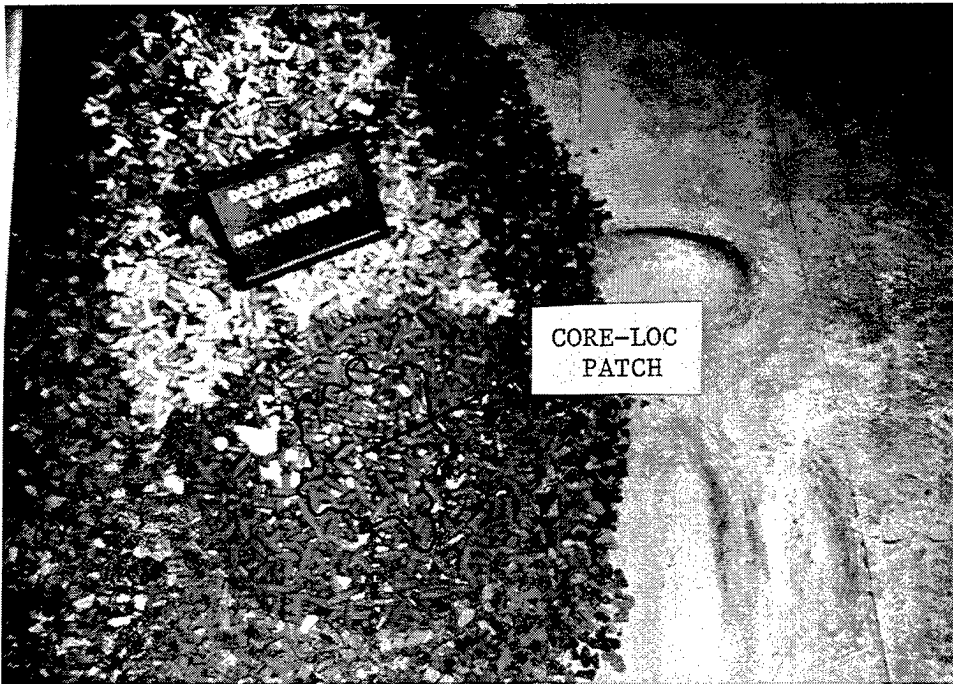

Photo A4. TS1, after 3 hr 15 min. Core-Loc patch still intact



Photo A5. Test Sequence 3 (TS3), $T_p = 1.84$ sec, new dolos armor

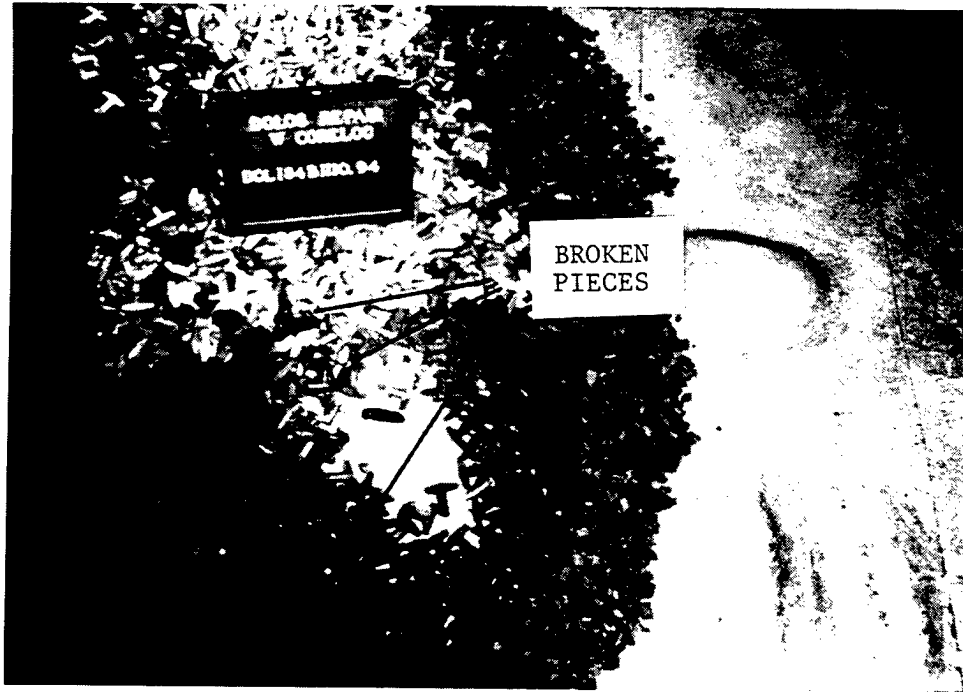

Photo A6. TS3, dolos armor failed after 2 hr. Note pieces of broken dolosse

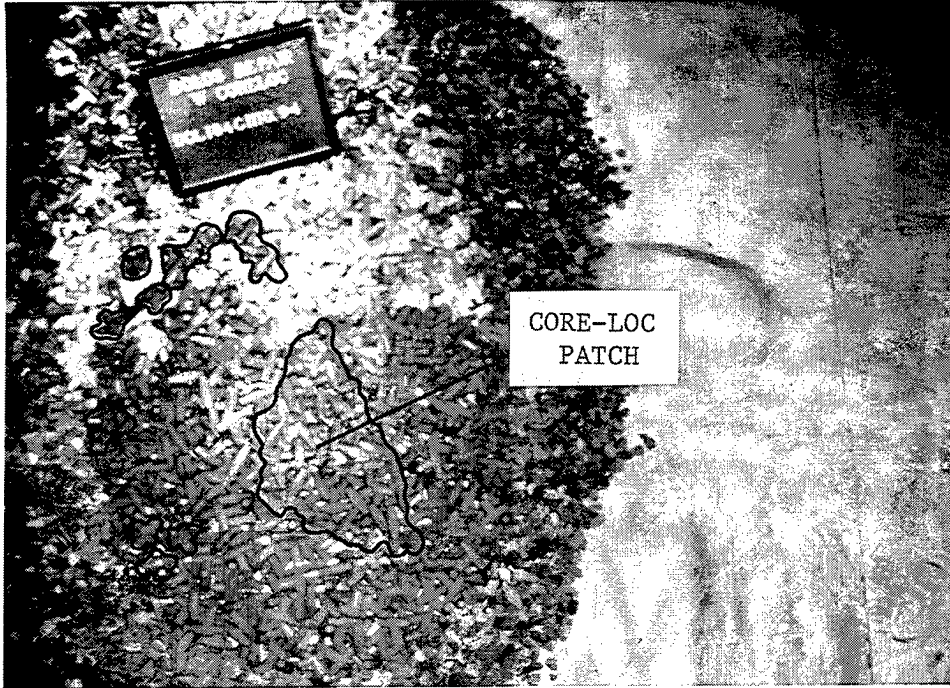

Photo A7. TS3, repair with Core-Loc. Note single unit spot repair on lee side of breakwater



Photo A8. TS3, damage to Core-Loc repair after 2 hr

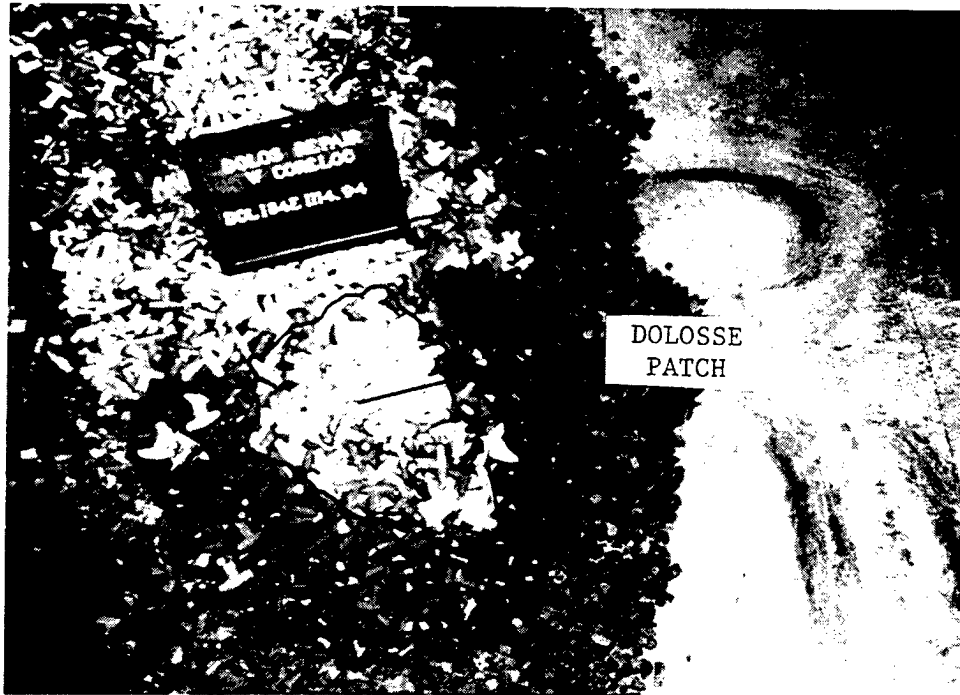

Photo A9. TS3, dolos repair of dolos armor

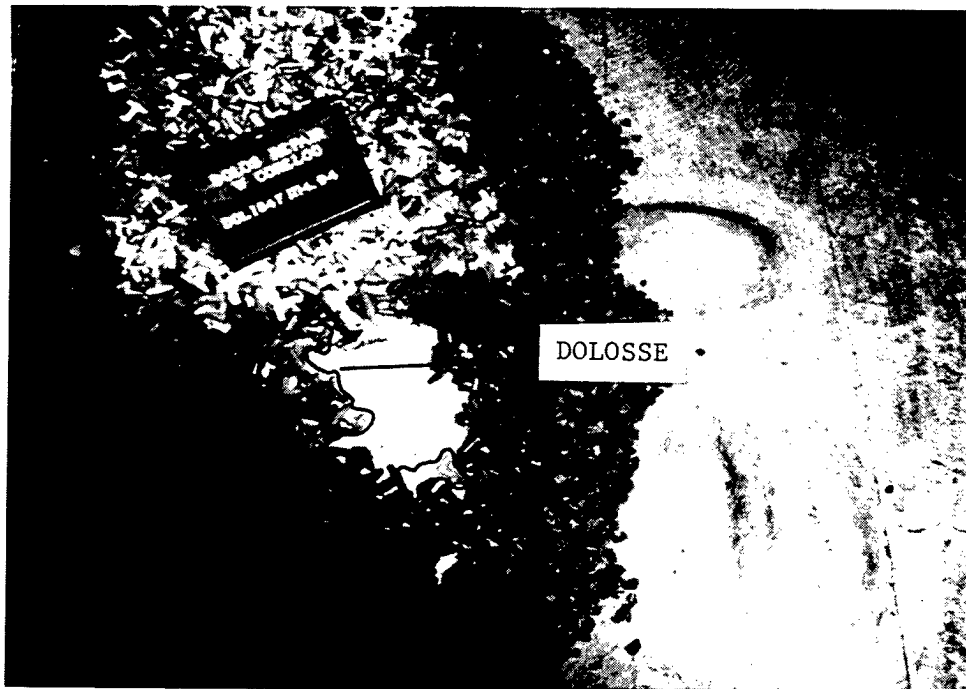

Photo A10. TS3, damage to dolos repair of dolos armor after 1 hr 45 min

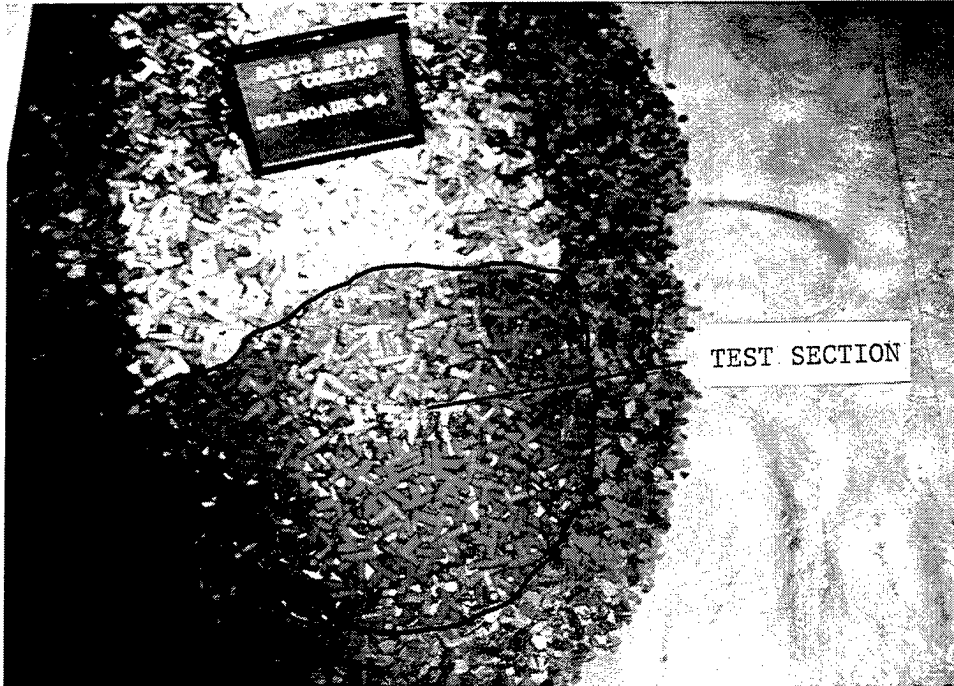

Photo A11. Test Sequence 5 (TS5) $T_p = 2.4$ sec. New dolos armoring



Photo A12. TS5. Damage on breakwater after 45 min

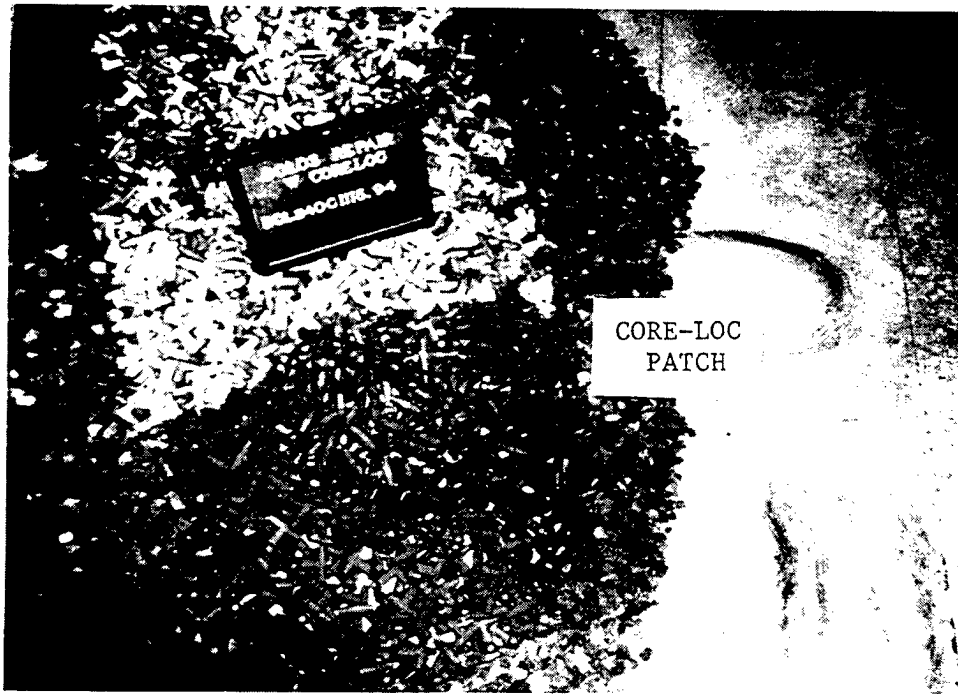

Photo A13. TS5. Repair of dolos armor with Core-Loc

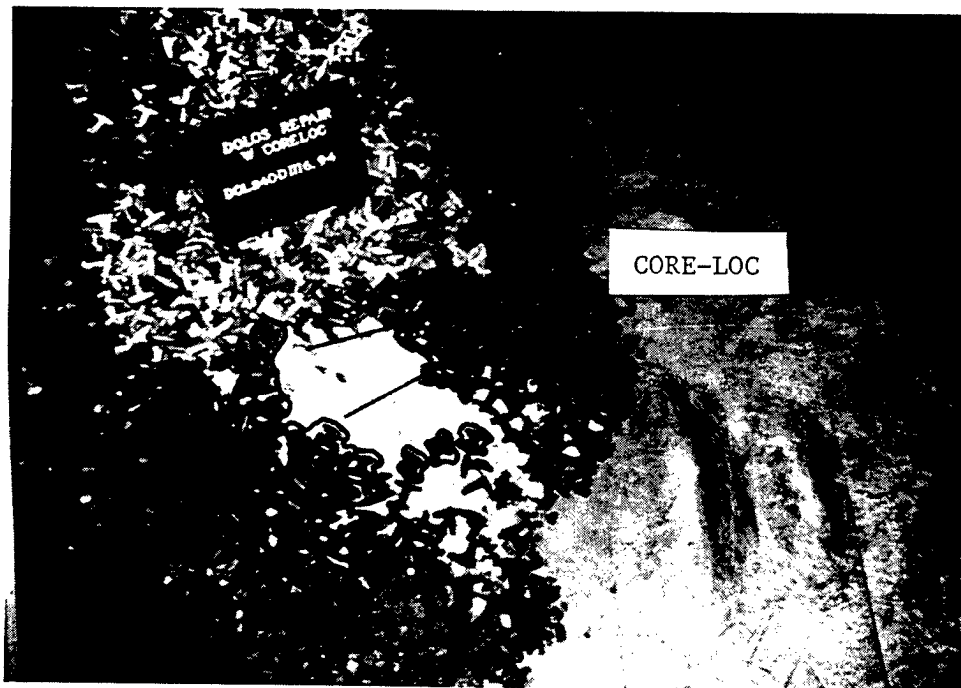

Photo A14. TS5. Catastrophic damage to Core-Loc-repaired breakwater after 1 hr 41 min

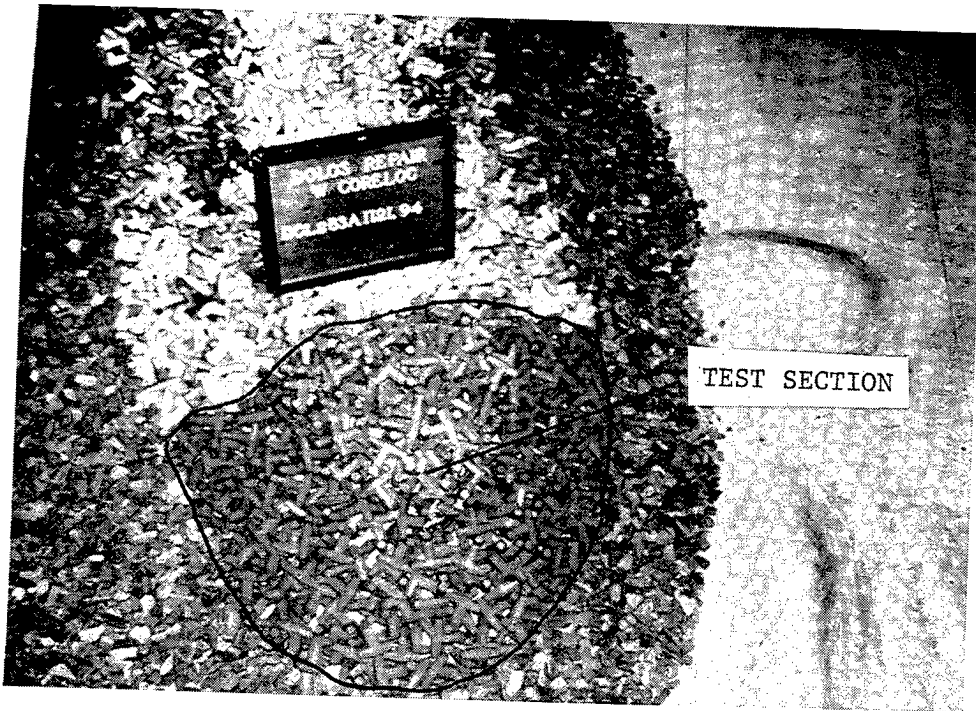

Photo A15. Test Sequence 7 (TS7), $T_p = 2.83$ sec. New dolos armoring

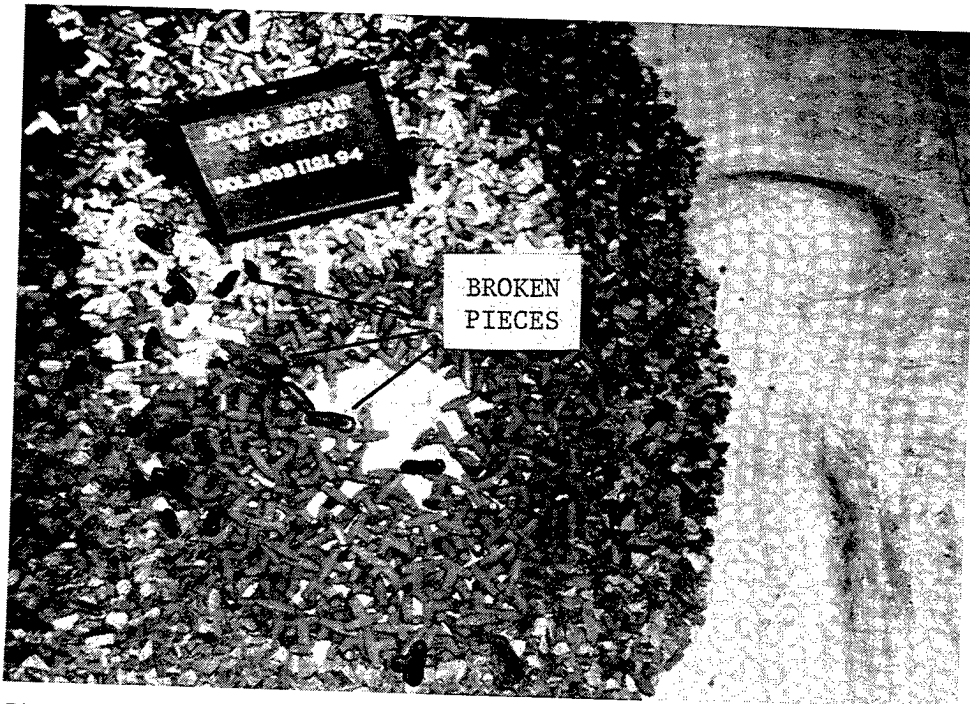

Photo A16. TS7. Damage to dolos armor after 45 min of wave attack



Photo A17. TS7. Core-Loc repair of dolosse armor

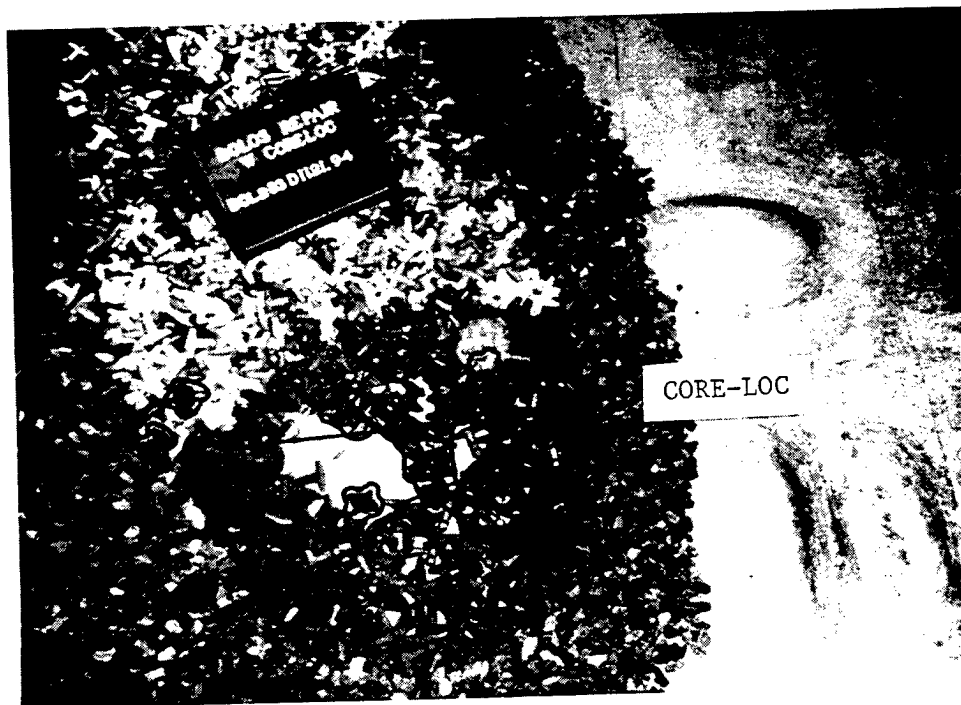

Photo A18. TS7. Damage to Core-Loc repair after 1 hr 30 min

REPORT DOCUMENTATION PAGE

Form Approved
OMB No. 0704-0188

Public reporting burden for this collection of information is estimated to average 1 hour per response, including the time for reviewing instructions, searching existing data sources, gathering and maintaining the data needed, and completing and reviewing the collection of information. Send comments regarding this burden estimate or any other aspect of this collection of information, including suggestions for reducing this burden, to Washington Headquarters Services, Directorate for Information Operations and Reports, 1215 Jefferson Davis Highway, Suite 1204, Arlington, VA 22202-4302, and to the Office of Management and Budget, Paperwork Reduction Project (0704-0188), Washington, DC 20503.

1. AGENCY USE ONLY (Leave blank)		2. REPORT DATE August 1997	3. REPORT TYPE AND DATES COVERED Final report	
4. TITLE AND SUBTITLE Preliminary 3-D Testing of CORE-LOC™ as a Repair Concrete Armor Unit for Dolos-Armored Breakwater Slopes			5. FUNDING NUMBERS	
6. AUTHOR(S) George F. Turk, Jeffrey A. Melby				
7. PERFORMING ORGANIZATION NAME(S) AND ADDRESS(ES) U.S. Army Engineer Waterways Experiment Station 3909 Halls Ferry Road, Vicksburg, MS 39180-6199			8. PERFORMING ORGANIZATION REPORT NUMBER Technical Report REMR-CO-18	
9. SPONSORING/MONITORING AGENCY NAME(S) AND ADDRESS(ES) U.S. Army Corps of Engineers Washington, DC 20314-1000			10. SPONSORING/MONITORING AGENCY REPORT NUMBER	
11. SUPPLEMENTARY NOTES Available from National Technical Information Service, 5285 Port Royal Road, Springfield, VA 22161.				
12a. DISTRIBUTION/AVAILABILITY STATEMENT Approved for public release; distribution is unlimited.			12b. DISTRIBUTION CODE	
13. ABSTRACT (Maximum 200 words) This report documents the first evaluation of CORE-LOC™ (Core-Loc) concrete armor units to repair dolos-armored breakwater slopes. The U.S. Army Engineer Waterways Experiment Station is investigating the Core-Loc armor unit because of its superior structural and stability characteristics and its ability to interlock with dolosse. The study reported herein is based on the results of three-dimensional physical model testing. Degradation of a dolos-armored breakwater head section is physically modeled at small scale. Modeling was done in such a way as to reproduce damage as realistically as possible without the added expense of actually scaling the structural strength of the armor units. For these tests, once an armor unit fully displaced from its original position, it was considered broken. Because of time and budget constraints, this investigation focusses on the performance of Core-Loc when used to repair armor using the spot repair method. Future tests of Core-Loc-repaired dolos slopes using the V-notch method are planned.				
14. SUBJECT TERMS Concrete armor units Core-Loc Dolos			15. NUMBER OF PAGES 46	
			16. PRICE CODE	
17. SECURITY CLASSIFICATION OF REPORT UNCLASSIFIED	18. SECURITY CLASSIFICATION OF THIS PAGE UNCLASSIFIED	19. SECURITY CLASSIFICATION OF ABSTRACT	20. LIMITATION OF ABSTRACT	