

REPORT DOCUMENT PAGE

Standard form 298 (Rev. 2-89)
facsimile

Public reporting burden for this collection of information is estimated to average 1 hour per response, including the time for reviewing instructions, searching existing data sources, gathering and maintaining the data needed, and completing and reviewing the collection of information. Send comments regarding this burden estimate or any other aspect of this collection of information, including suggestions for reducing this burden to Washington Headquarters Services, Directorate for Information Operations and Reports, 1215 Jefferson Davis Highway, Suite 1204, Arlington, VA 22202-4302, and to the Office of Management and Budget, Paperwork Reduction Project (0704-0188), Washington, DC 20503.

1. AGENCY USE ONLY (Leave blank)		2. REPORT DATE 22 October 1997	3. REPORT TYPE AND DATES COVERED Final technical report 15 Feb. 1994 through 15 May 1997	
4. TITLE AND SUBTITLE High-Power CW Diode-Laser-Array-Pumped Solid-State Lasers and Efficient Non-Linear-Optical Frequency Conversion			5. FUNDING NUMBERS Contract DAAH04-94-G-0019	
6. AUTHORS W. Tulloch, T. Rutherford, R. K. Route, R. L. Byer				
7. PERFORMING ORGANIZATION NAME(S) AND ADDRESSES Edward L. Ginzton Laboratory Stanford University Stanford, CA 94305-4085			8. PERFORMING ORGANIZATION REPORT NUMBER Ginzton Lab. Report No. <u>5563</u>	
9. SPONSORING/MONITORING AGENCY NAME(S) AND ADDRESS(ES) U.S. Army Research Office P.O. Box 1211 Research Triangle Park, NC 27709-2211			10. SPONSORING/MONITORING AGENCY REPORT NUMBER <i>ARO 32333. 7-PH</i>	
11. SUPPLEMENTARY NOTES The view, opinions and/or findings contained in this report are those of the author(s) and should not be construed as an official Department of the Army position, policy, or decision, unless so designated by other documentation.				
12a. DISTRIBUTION/AVAILABILITY STATEMENT Approved for public release; distribution unlimited.			12b. DISTRIBUTION CODE	
13. ABSTRACT (Maximum 200 words) <p>The goals of this program were: development of high-power, cw diode-laser-array-pumped, Nd:YAG lasers, and efficient nonlinear frequency conversion of their output. Two minislabs laser heads constructed as a single high power dual-head oscillator (96W, multi-mode) were operated separately to support Q-switched and cw nonlinear frequency conversion studies and single-frequency injection-locking studies and the start of cw amplifier research. A cw singly resonant optical parametric oscillator (SRO) utilizing bulk periodically poled LiNbO₃ (PPLN) for tunable mid-IR radiation using the Q-switched laser as the pump was developed, and SHG output at 532 nm was increased from 800 mW average power (15 KHz rep rate) to 1300 mW average power (8.4 KHz rep rate).</p> <p>Coherent laser radar with high-power, high-coherence sources was pursued through a highly-coherent master oscillator cw power amplifier approach. We operated one laser head as a (10W TEM₀₀) oscillator and the second laser head as a triple-pass amplifier achieving 26 W TEM₀₀ output. More extensive experiments on cw diode-laser pumped laser amplifiers for high-power, high-coherence sources were carried out to test the ability of theoretical modeling to predict amplifier output power.</p> <p style="text-align: right;">DTIC QUALITY INSPECTED 2</p>				
14. SUBJECT TERMS Diode-pumped solid-state lasers, high average power solid state lasers, nonlinear frequency conversion			15. NUMBER OF PAGES 52	
			16. PRICE CODE	
17. SECURITY CLASSIFICATION OF REPORT UNCLASSIFIED	18. SECURITY CLASSIFICATION OF THIS PAGE UNCLASSIFIED	19. SECURITY CLASSIFICATION OF ABSTRACT UNCLASSIFIED	20. LIMITATION OF ABSTRACT UL	

**High-Power CW Diode-Laser-Array-Pumped Solid-State Lasers
and
Efficient Non-Linear-Optical Frequency Conversion**

Final Technical Report
for the period
15 February 1994 through 15 May 1997

Principal Investigator
Professor Robert L. Byer
Applied Physics Department
and
Center for Nonlinear Optical Materials
Stanford University
Stanford, California 94305-4085

Ginzton Laboratory
Report Number 5563
SPO No. 13764

Report date
October 1997

Prepared for
U. S. Army Research Office

Contract Number DAAH04-94-G-0019

APPROVED FOR PUBLIC RELEASE;
DISTRIBUTION UNLIMITED.

19971203 038

Final Technical Report

I.	Table of Contents	i
II.	List of Appendices, Illustrations and Tables	ii
III.	Technical Results	1
	A. Statement of the Problem Studied	1
	B. Summary of Most Important Results	1
	1. High Power Laser Source Development	
	a. A 40 W diode-laser-pumped TEM ₀₀ Nd:YAG minislab laser	1
	b. A 20 W diode-laser-pumped, injection-locked, Nd:YAG laser oscillator	4
	c. A 96 W multimode diode-laser -pumped Nd:YAG minislab laser	6
	d. A 20 W CW diode-laser-pumped TEM ₀₀ Nd:YAG minislab amplifier	7
	e. A 20 W average power Q-switched Nd:YAG minislab laser	8
	2. Efficient Nonlinear Frequency Conversion in PPLN	9
	a. A CW singly resonant optical parametric oscillator	10
	b. 532 nm-pumped optical parametric oscillator	12
	c. Single pass efficient second harmonic conversion	13
	C. List of All Publications and Technical Reports	14
	D. List of all Participating Scientific Personnel	15
IV.	Report of Inventions	16
V.	Bibliography	17
VI.	Appendices	19

II. List of Figures and Tables

Fig. 1	Output power of the slab Nd:YAG laser versus input diode laser pump power for multitransverse transverse mode operation and TEM ₀₀ mode operation.	2
Fig. 2	Schematic of laser head.	3
Fig. 3	Schematic of the TEM ₀₀ Nd:YAG zig-zag slab laser resonator.	4
Fig. 4	Schematic of injection locked ring cavity utilized for single frequency operation of the high power laser.	5
Fig. 5	Multimode output power of the single slab and dual slab oscillator.	6
Fig. 6	Peak power and high average power operation of an acousto-optically Q-switched Nd:YAG slab laser oscillator.	8
Fig. 7	Experimental set-up for multigrating QPM OPO and the OPO tuning function achieved by translating the PPLN crystal through 24 different grating sections.	11
Fig. 8	Output wavelength vs crystal temperature for CW 532 nm-pumped singly-resonant PPLN OPO.	12
Fig. 9	CW single-pass second harmonic generation internal conversion efficiency and internal second harmonic power for a 5.3 cm long uncoated PPLN sample. This result represents the highest cw single pass SHG conversion efficiency to date.	13

III. Technical Results

A. Statement of the Problem Studied

The goal of the High-Power CW Diode-Laser-Array-Pumped Solid-State Lasers and Efficient Nonlinear Optical Frequency Conversion Program at Stanford has been the study of the engineering difficulties associated with the development of high average power laser systems and the development of efficient, engineerable nonlinear optical materials.

B. Summary of the Most Important Results

1. High Power Laser Source Development

a. 40 W diode-laser-pumped TEM₀₀ Nd:YAG minislabs laser

We have built a diode-laser-pumped Nd:YAG slab laser that emits 70 W cw in multitransverse transverse mode operation when pumped with 235 W of diode-laser power, 40 W cw in a TEM₀₀ mode when pumped with 212 W of diode-laser power.¹ The input-output curve for the laser in multifrequency operation is shown in Figure 1. This zig-zag slab laser has thermally induced distortions of less than one wave at the full pump power. A significant advantage of our design over previous slab lasers is a patented Teflon AF[®] protective coating on the slab total internal reflection surfaces which greatly simplifies the mounting and cooling of the slab laser medium.² Although the slab laser design has been used successfully in diode-laser-pumped, pulsed laser systems,^{3,4} this is the first uniformly face-pumped, face-cooled, cw, diode-pumped slab laser.

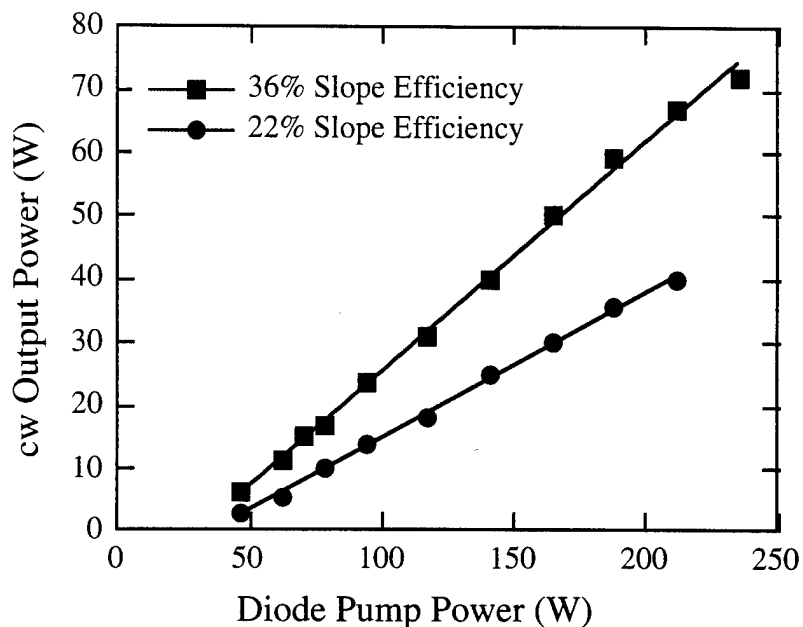

Fig. 1. Output power of the slab Nd:YAG laser versus input diode laser pump power for multitransverse transverse mode operation (squares) and TEM₀₀ mode (circles) operation.

Figure 2 shows a schematic of the laser head. The Nd:YAG slab is mounted in an aluminum frame and sealed at both ends. We place the O-rings just as one would on a rod with no care taken to locate the O-rings away from a bounce point since the slab is protected by the low index Teflon coating. The top and bottom of the slab are insulated by placing gold-coated glass microscope slides in contact with the Nd:YAG slab. The glass slides are pressed in place by a small spring loaded teflon slab to avoid excess pressure on the Nd:YAG slab. The last two sides of the frame contain the fiber pump modules. The Nd:YAG slab is water cooled with 2 mm thick water channels flowing between the slab surfaces and the brass fiber holders. The water flows at a rate of 1 liter per minute. The fibers are isolated from the water flow by a 0.5 mm anti-reflection (AR) coated sapphire window glued onto the brass mount.²

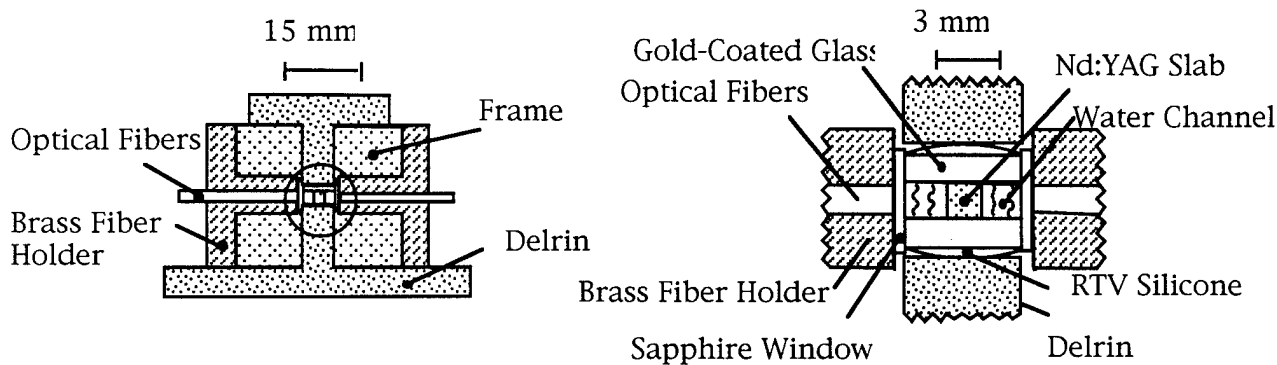

Fig. 2. Schematic of laser head. The thick black lines on the glass slides and brass fiber holders represent gold coatings to confine the pump light.

The diode lasers are mounted on a water-cooled block well away from the laser head, thus separating the heat loads. Two simple clamps hold all the fibers in the laser head assembly, reducing the laser head size and complexity. The pump sources for our laser are twenty five SDL-3450-P5 fiber-coupled diode lasers (SDL, Inc.). Each 600 μm , 0.4 numerical aperture (N.A.) fiber emits a maximum of 9.5 watts for a total of 235 watts at the slab.

The slab has a thickness of 1.7 mm, a width of 1.8 mm and a centerline length of 58.9 mm. This length corresponds to 22 TIR bounces and is chosen to operate at 50% of the stress fracture limit at the full pump power of 235 W. Although we do not take full advantage of the slab design because of the small aspect ratio, we still minimize the effects of stress birefringence and thermal lensing, and obtain a nearly diffraction-limited mode with high efficiency.

To obtain the benefits of the slab design, the laser gain medium must be efficiently and uniformly pumped. The interior surface of the brass fiber holder is polished and gold coated. The fiber locations are chosen to increase both the reflectivity of the unabsorbed pump power from the opposite fiber holder and to increase the pump uniformity. The 2.5 mm space between the fiber ends and the slab face and high N.A. of the fibers also act to improve the uniformity of the pump power deposition within the Nd:YAG slab.

The best performance was obtained with a three mirror folded cavity as shown in Figure 3. The zig-zag geometry averages out the thermal lens in the zig-zag plane, however a small thermal lens remains in the plane perpendicular to the zig-zag direction due to incomplete isolation of the top and bottom of the slab. This asymmetric thermal lens is compensated by using the astigmatism

from an off-axis concave mirror. A 20 cm radius of curvature mirror was chosen to dominate the thermal lensing in the cavity and the fold angle necessary to obtain TEM₀₀ mode operation at full power was 45°.

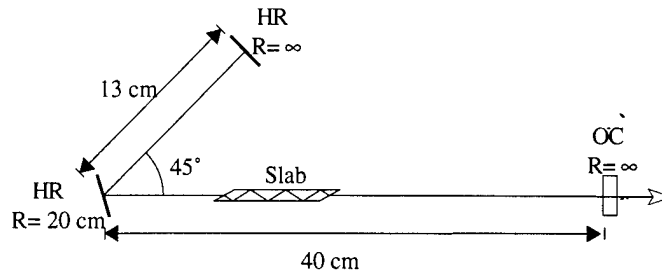

Fig. 3. Schematic of the TEM₀₀ Nd:YAG zig-zag slab laser resonator. The off-axis spherical mirror compensates for the residual thermally induced cylindrical lens.

The mode size in the Nd:YAG slab is 500 μm and can be changed by small displacements in the short 13 cm leg. It is adjusted so that clipping around the Nd:YAG slab prevents higher order modes from oscillating. TEM₀₀ mode operation was confirmed by displaying the beat note from a fast photodetector on a spectrum analyzer as well as monitoring a portion of the output beam with a scanning slit. We obtained 40 W in a TEM₀₀ mode at a pump power level of 212 W. The slope efficiency for TEM₀₀ mode operation was 22%. The M^2 value was measured using the knife edge technique and was found to be less than 1.3 in both directions. The output is polarized due to the Brewster slab faces with a polarization ratio better than 100:1.

b. A 20 W diode-laser-pumped, injection-locked, Nd:YAG laser oscillator

Applications such as coherent laser radar and gravitational wave detection interferometry require high power single frequency sources. Low power diode-laser-pumped monolithic NonPlanar-Ring Oscillators (NPRO) have proven to be the most stable solid state laser source available. Utilizing this stable oscillator as the master oscillator, a high power oscillator can be frequency stabilized and forced to operate as a single frequency oscillator by a technique known as injection-locking. Injection-locking consists of injecting the

output of the master oscillator into the optical resonator of the laser to be stabilized, the slave oscillator. Typically the master-laser output power is a small fraction of the slave-laser output power. If the frequency difference between the master and slave oscillators is sufficiently small the free-running mode of the slave laser is extinguished and the slave laser is frequency-locked to the master laser. This frequency stabilization is accomplished without introducing optical elements into the slave laser cavity and requires a relatively simple feedback loop. Injection-locking is a powerful technique for reducing the frequency noise of a high-power laser oscillator.⁵

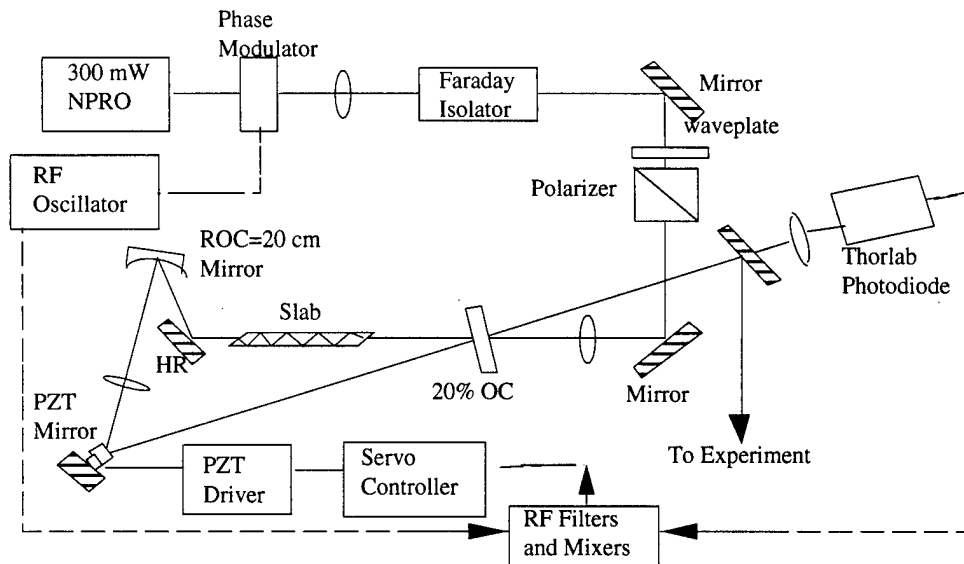

Fig. 4. Schematic of injection locked ring cavity utilized for single frequency operation of the high power laser. Included in the schematic are the phase modulator and RF electronics required for Pound-Drever locking of the NPRO to the slave laser.

We have converted the standing-wave cavity shown in figure 3 to a ring cavity and injection locked the laser with a 300 mW NPRO to obtain single frequency operation as presented in figure 4. The injection locked laser produces 20 Watts of output power, at 190 W of diode-laser pump power, in single axial mode and has remained injection locked for an hour without operator intervention.

c. A 96 W multi-mode diode-laser-pumped Nd:YAG minislabs laser

The ability to scale the zig-zag slab laser geometry to higher powers was demonstrated in a simple modular laser design based on our experience with the minislabs laser heads described in the previous sections. We built a second fiber coupled diode-laser-pumped laser head identical to the existing laser head, an additional 25 fiber coupled diode lasers were purchased. Figure 5 shows the results of a high power laser oscillator with two identical laser heads end-to-end in a linear laser cavity. With both laser heads aligned in this dual head configuration a total output power of 96 watts was measured with a pump power of 437 watts. The slope efficiency was 25% and a threshold at 50 watts pump power was observed.²

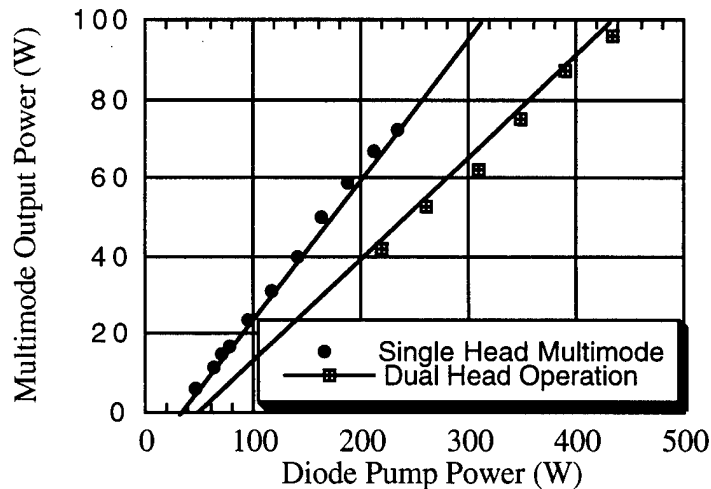

Fig. 5. Multimode output power of the single slab and dual slab oscillator.

This technique for power scaling, although a useful demonstration, does not take advantage of the zig-zag slab laser geometry. By doubling the length of the laser medium, the residual cylindrical thermal lens is made stronger in this configuration. Techniques to compensate for this increased thermal effect, such as rotating the second laser head by 90 degrees, have been effective in rod

geometry lasers. The slab geometry also provides several techniques for scaling to higher powers through redesign of the slab dimensions and modification of the laser head. The slab width could be doubled for the original length slab, the pump power doubled to the 437 W level, and the mode volume of the cavity increased to extract power to the 100 W level. However, potentially the most useful method for power scaling is the use of amplifiers to increase the power after a stable laser oscillator. Power scaling through the use of a master oscillator power amplifier (MOPA) configuration is a standard technique for high power operation in pulsed laser systems. Preliminary experiments evaluating cw amplification have been completed and are described below.

d. A 20 W CW diode-laser-pumped TEM₀₀ Nd:YAG minislab amplifier

The use of a master oscillator and power amplifiers (MOPA) configuration is a standard technique for building high power pulsed laser sources. Due to the very high gains of pulsed laser sources single or multiple pass amplification is an important technique for high power operation.⁶ However, in cw laser systems the gain is usually too low to consider cw amplification. The development of high gain diode-laser-pumped solid state lasers, such as the Stanford diode-pumped minislab laser, has allowed for compact high gain cw laser development. While the cw laser gain is still much lower than traditional pulsed laser gains the cw gain is now high enough to consider cw amplification as a viable alternative to building very high power oscillators.

The Franz-Nodvik equation describing the operation of amplifiers as a function of gain, amplifier length, saturation intensity and the incident intensity is well known⁷ and preliminary experiments have been completed to demonstrate the operation of the cw amplifiers. Shine initially demonstrated a cw Nd:YAG slab amplifier utilizing the two laser heads described in the previous sections. One laser head was configured as a 40 W multimode laser oscillator and the second head was used as a single pass amplifier. The amplifier operated with a small signal gain of $e^{0.9}$ or 240 % per pass. For 40 W of input power the single pass amplifier generated 64 W of output power for a partially saturated single pass power gain of 60 %.² This demonstrated

effective power extraction from a single pass amplifier in the saturated amplifier regime.

An additional demonstration of the operation of the amplifier as a multipass device for more efficient power extraction was completed. Starting with a commercial multi-axial mode 8.5 W diode-laser-pumped oscillator, a triple-pass amplifier system was demonstrated. Utilizing an angle-multiplexing technique for separating different amplifier passes by allowing a different number of TIR bounces in the slab we generated 20 watts output power for 7 watts incident on the first pass of the amplifier. This angle-multiplexing technique will be replaced by a simpler polarization coupling scheme in future amplifier systems when new slabs are available without Brewster angle faces.

These demonstrations provide experimental verification of the amplification theory and provide the insights required to develop high gain cw amplifiers for the next generation high power laser systems.

e. A 20 W average power Q-switched Nd:YAG minislabs laser

High repetition rate, high average power laser sources are required for a variety of applications including; free space coherent communications, infrared countermeasures, target imaging or profiling, and efficient nonlinear frequency conversion devices. The slab lasers developed for cw applications are well suited for pulsed operation at high repetition rates, where the thermal effects are the same as in the cw case. Q-switching at these repetition rates, typically from 10-100 kHz for Nd:YAG, is typically achieved by installing an acousto-optic (AO) Q-switch in the system oscillator. Figure 6 shows the experimental results of the water-cooled Nd:YAG slab laser oscillator as an AO Q-switched laser generating 20 watts average power at 14 kHz. At 20 kHz an average power of 19 W and a pulse energy of 1.9 mJ was demonstrated. The pulse length was measured to be below 100 ns in this configuration. These 10 kW peak powers makes this AO Q-switched laser a useful source for many nonlinear optical frequency conversion.

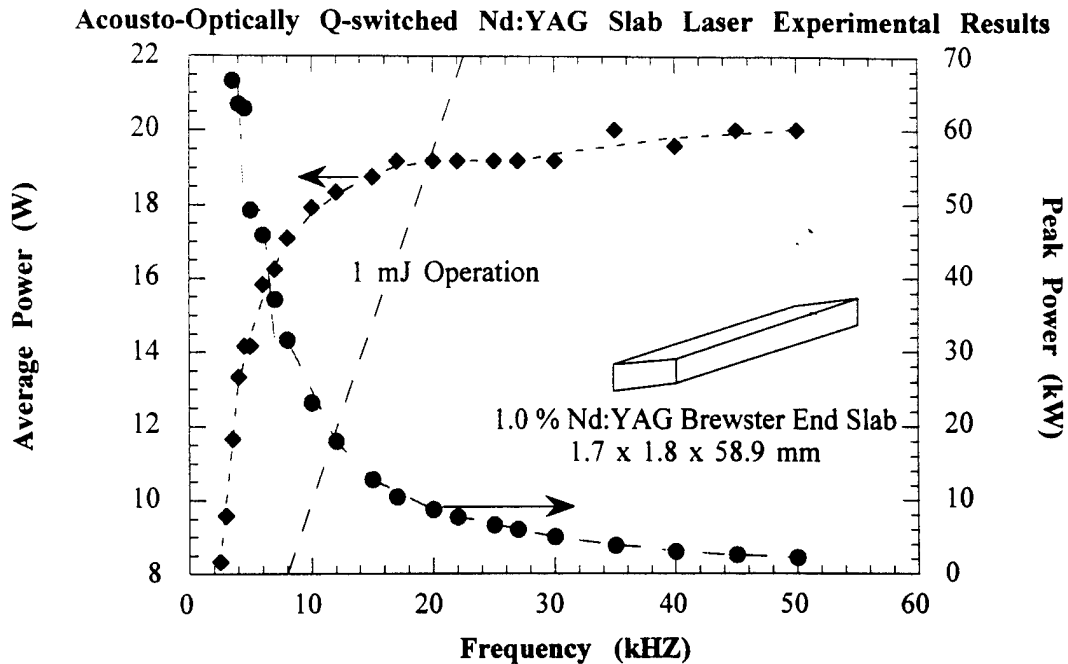

Fig. 6. Peak power and high average power operation of an acousto-optically Q-switched Nd:YAG slab laser oscillator. The low loss acousto-optic Q-switch allows the oscillator to operate at an average power equal to the cw operating point.

2. Efficient Nonlinear Frequency Conversion in PPLN

In a quasi-phased-matched (QPM) material phase velocity mismatch between the fundamental and the second harmonic is compensated by modulating the nonlinear coefficient with a period twice the coherence length of the interaction.⁸ Thus any interaction within the transparency range of the material can be noncritically phased-matched at a specific temperature and the interacting waves can be chosen so that coupling occurs through the largest element of the $c^{(2)}$ tensor. However, implementation of QPM requires a fabrication method that can achieve uniform micron-scale periodic structures while preserving the materials transparency, nonlinearity and power handling capacity.⁹

Yamada's¹⁰ electric-field poling success led Byer and Fejer to initiate an electric-field poling study at the Center for Nonlinear Optical Materials at

Stanford University in March of 1992. By September 1993, Myers inverted domains at room temperature in 1/2 mm thick, LiNbO₃ wafer sample without dielectric breakdown. Standard lithographic techniques and custom designed electrodes for electric field poling are used to fabricate domains in a controlled pattern necessary for nonlinear optical applications. In March of 1994, a sample 5 mm in length was tested by difference frequency mixing and was shown to be of high optical quality. By early summer of 1994, the first QPM OPO had been demonstrated in bulk periodically poled lithium niobate (PPLN).¹¹

Progress in the preparation of PPLN continued with phasematching lengths increasing from 5 mm to 9 mm and then to 15 mm by the end of 1994. Today 25 mm lengths are being prepared with nearly 100% yield. Further, the material has proven to be of very high optical quality with losses of the order of bulk lithium niobate. The high optical quality, coupled with large nonlinear coefficient used in the PPLN QPM interaction, led to the first cw diode pumped OPO using PPLN¹²

PPLN is capable of handling peak fluence levels of 1J/cm² and cw average power levels in excess of 10 MW/cm². With crystals only 1/2 mm thick, over 10 mJ of pulse energy can be accommodated without optical fracture. For the same size sample, more than 1 kW of cw average power can be handled without damage to the lithium niobate. The PPLN material is also capable of generating output wavelengths as short as 390 nm in the UV. To accomplish the phasematching to this short wavelength, the domain must be inverted with 3μm periods. Electric-field poling at room temperature has to date allowed poling to 6 μm periods, a period suitable for the harmonic generation of 532 nm from the 1064 nm fundamental.

a. A CW singly resonant optical parametric oscillator

OPO's convert a pump wave frequency into two frequency waves in a second order nonlinear optical material. Energy conservation defines the waves frequency relationship, $w_s + w_i = w_p$, where w_s is the generated signal wave, w_i is the generated idler wave, and w_p is the pump wave frequency. Tunability is achieved by phasematching for the desired frequency generation. Conventional OPOs rely on temperature or angle tuning for phasematching,

PPLN can be engineered with different domain periods to control the frequency range of the generated waves at a given temperature.

CW operation of a singly resonant oscillator (SRO) is known to be stable, but with a high threshold. Only recently have OPO materials such as PPLN demonstrated enough gain to consider SROs as practical devices. Using a 50 mm PPLN crystal, with $29.75 \mu\text{m}$ periods, AR coated at the signal wavelength of $1.54 \mu\text{m}$, and heated to 175 C , Myers demonstrated a SRO threshold less than 3 W . An output power of 0.4 W at $1.57 \mu\text{m}$ and 2.5 W at $3.3 \mu\text{m}$ was demonstrated with a pump power of 4 W at $1.064 \mu\text{m}$.¹³ With the proper optics a PPLN SRO pumped by the 1064 nm Nd:YAG laser line can generate tunable radiation from $1.3 - 4.5 \mu\text{m}$, limited at the long wavelengths by the transparency range of lithium niobate.

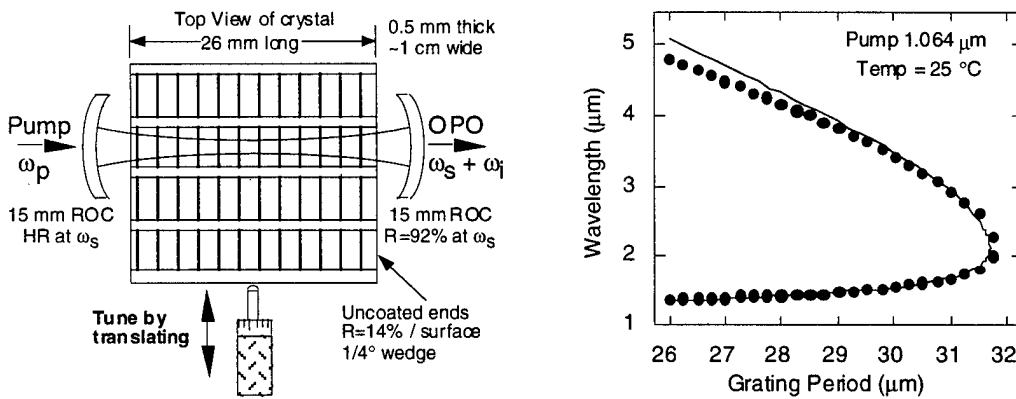

Fig. 7. Experimental set-up for multigrating QPM OPO and the OPO tuning function achieved by translating the PPLN crystal through 24 different grating sections. Fine tuning is accomplished by crystal temperature adjustment. Phasematching is noncritical for all points. No realignment is necessary.

Figure 7 shows the operation of a cw Optical Parametric Oscillator (OPO) which tunes across the 1.4 to $4.5 \mu\text{m}$ spectral region by moving the crystal through the resonator cavity. In this case, the engineered nonlinear crystal has 25 OPOs on a single Lithium Niobate chip, each with a slightly different grating pitch.¹⁴ The OPO operated for over six months without optical damage showing a high degree of reliability. These results are indicative of the potential to frequency convert Nd:YAG lasers at high

efficiency, and potentially at high average power, to generate tunable output across the near infrared.

b. 532 nm-pumped optical parametric oscillator

A PPLN SRO, pumped by 532 nm doubled Nd:YAG can generate radiation from the visible to the mid-IR. Initial experiments utilizing a commercial 5 W TEM₀₀ multilongitudinal mode 532 nm pump laser and a 5 cm long 0.5 mm thick PPLN crystal demonstrated an SRO operating with a 1 W threshold, and 0.9 W of idler output for 4.3 W of pump.¹⁵ The pump beam was chopped with a 50% duty cycle to reduce the thermal loading of the PPLN crystal. Continuous tuning from 953-1000 nm for the signal and 1160-1234 nm for the idler was demonstrated. This low threshold demonstration sets the stage for device development based on tunable PPLN SRO technology that can be coupled to commercial pump lasers for 1 W level operation. Figure 8 shows the OPO output wavelength as a function of crystal temperature for the 532 nm pumped singly-resonant OPO.

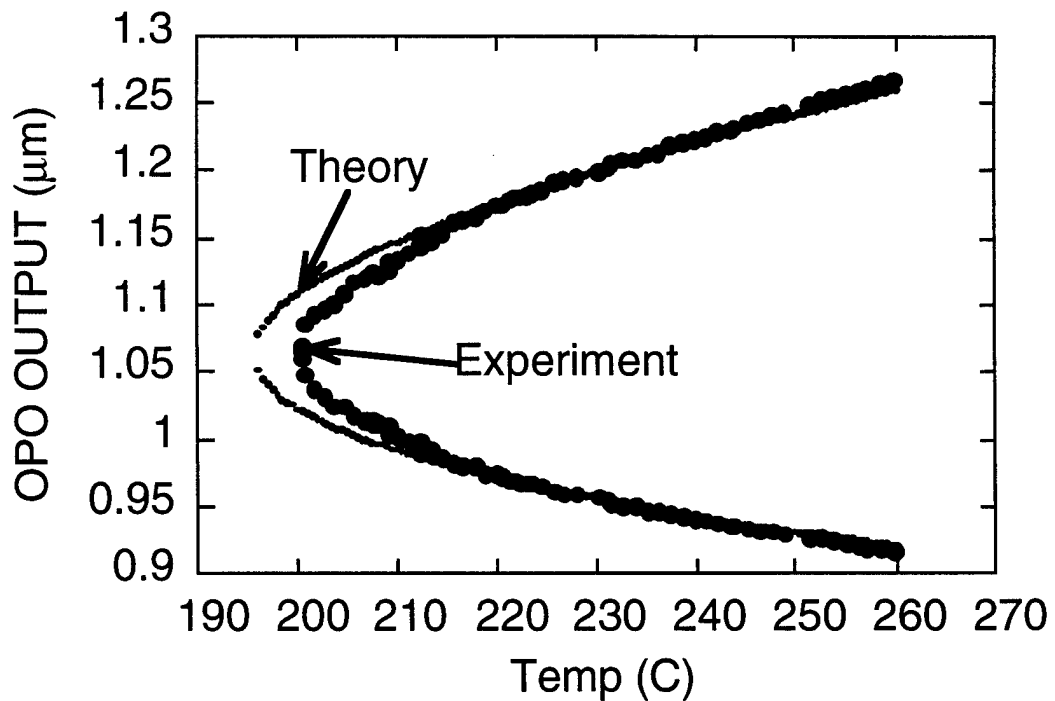

Fig. 8. Output wavelength vs crystal temperature for CW 532 nm-pumped PPLN singly-resonant OPO.

c. Single pass efficient second harmonic conversion

A recent breakthrough in PPLN technology for second harmonic generation of 532 nm radiation from the 1064 nm Nd:YAG fundamental was recently demonstrated.¹⁶ A 5 cm PPLN crystal with domain periods of 6.4 microns was fabricated for this SHG experiment. Figure 9 shows the 2.4 W 532 nm cw output power converted from a 6 W 1064 nm Nd:YAG laser in a single pass SHG experiment. The 40% conversion efficiency for single pass cw SHG is a world record and opens the door for simple SHG devices without the need for external resonators or intra-cavity doubling.

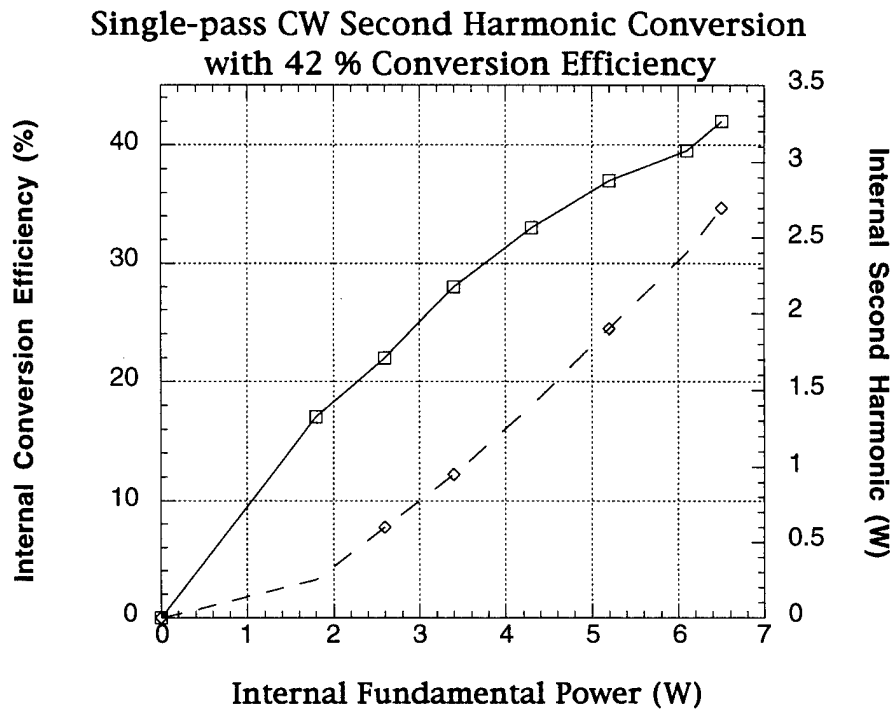

Fig. 9. CW single-pass second harmonic generation internal conversion efficiency and internal second harmonic power for a 5.3 cm long uncoated PPLN sample. This represents the highest cw single pass SHG conversion efficiency to date.

C. Publications and Technical Reports

R. J. Shine, Jr., A. J. Alfrey, and R. L. Byer, "Conduction cooled, continuous wave, diode-laser-pumped Nd:YAG mini-slab laser," OSA Proceedings on Advanced Solid-State Lasers, T. Y. Fan and B. H. T. Chai, eds. (Optical Society of America, Washington, DC, 1994), vol. 20, pp. 2-5.

R. J. Shine, jr., A. J. Alfrey, and R. L. Byer, "40-W cw, TEM₀₀-mode, diode-laser-pumped, Nd:YAG miniature-slab laser," Optics Letters, **20**, pp. 459-461, (March 1, 1995).

R. J. Shine, Jr., A. J. Alfrey, and R. L. Byer, "A 40 W CW, TEM₀₀ Mode, Diode-Laser-Pumped, Nd:YAG Slab Laser," in *OSA Proceedings on Advanced Solid-State Lasers*, vol. 24, Bruce H. T. Chai and Stephen A. Payne, eds. (Optical Society of America, Washington, D.C., 1995), pp. 216-218.

R. J. Shine, Jr., A. J. Alfrey, and R. L. Byer, "A 40 W CW, TEM₀₀ Mode, Diode-Laser-Pumped, Nd:YAG Zig-Zag Miniature-Slab Laser," in *SPIE Proceedings on Solid State Lasers and Nonlinear Crystals*, vol. 2379 (SPIE, Washington, 1995) pp. 112-119.

T. Taira, T. Kobayashi, W. M. Tulloch and R. L. Byer, "Single Axial Mode Oscillation of a Coupled-Cavity Yb:YAG Laser," in *OSA TOPS on Advanced Solid-State Lasers*, Vol. 1, (Optical Society of America, Washington, DC, 1996) pp. 14-15.

L.E. Myers, W.R. Bosenberg, J.I. Alexander, M.A. Arbore, M.M. Fejer and R.L. Byer, "CW Singly-resonant Optical Parametric Oscillators Based on 1.064 mm-pumped Periodically Poled LiNbO₃," in *OSA TOPS on Advanced Solid-State Lasers*, 1996, Vol. 1, (Optical Society of America, Washington, DC, 1996) pp. 35-37.

W.R. Bosenberg, A. Dobershoff, J.I. Alexander, L.E. Myers, W.M. Tulloch and R.L. Byer, "cw singly-resonant optical parametric oscillator based on periodically-poled LiNbO₃," in *Conference on Lasers and Electro-Optics*, 1996 Technical Digest Series, Vol. 9 (Optical Society of America, Washington, DC, 1996), pp. 340-341

D. Participating Scientific Personnel

contributing to
U. S. Army Research Office
Contract Number DAAH04-94-G-0019

Robert L. Byer	Principal Investigator, Professor of Applied Physics
Robert C. Eckardt	Senior Research Associate Ginzton Laboratory
Eric K. Gustafson	Senior Research Associate Ginzton Laboratory
Roger K. Route	Senior Research Associate Ginzton Laboratory
Anthony J. Alfrey	Post-Doctoral Student Applied Physics
Larry E. Myers	Graduate Student Electrical Engineering (Ph.D. 1995)
Thomas Plettner	Graduate Student Applied Physics
Todd Rutherford	Graduate Student Applied Physics
Robert J. Shine	Graduate Student Applied Physics (Ph.D. 1995)
William Tulloch	Graduate Student Electrical Engineering

IV. Inventions and Disclosures

1. "Improved Protective Coating for Solid State Slab Lasers"

V. Bibliography

- 1 R.J. Shine, Jr., A.J. Alfrey, and R.L. Byer, "A 40 W cw, TEM₀₀ Mode, Diode-Laser-Pumped, Nd:YAG miniature-Slab Laser", *Optics Letters* (1 March. 1995) vol. **20**, no. 5, p. 459-462.
- 2 R.J. Shine, Jr., "A High-Power, Diode-Laser-Pumped, Solid-state Laser For Precision Interferometry", (Ph.D. Dissertation Department of Applied Physics, Stanford University, August 1995)
- 3 B. J. Comaskey, R. Beach, G. Albrecht, W. J. Benett, B. L. Frietas, C. Petty, D. VanLue, D. Munding and R. W. Solarz, "High Average Power Diode Pumped Slab Laser," *IEEE, JQE-28*, p. 992 (1992)
- 4 R. J. St. Pierre, H. Injeyan, R. C. Hilyard, M. E. Weber, J. G. Berg, M. G. Wickham, C. S. Hoefler and J. P. Machan, "One Joule per Pulse, 100 Watt, Diode-Pumped, Near Diffraction Limited, Phase Conjugated, Nd:YAG Master Oscillator Power Amplifier" in *Diode Pumping of Average-Power Solid State Lasers*, Technical Digest, Proc. of SPIE, vol 1865, p. 2 (1993)
- 5 A.D. Farinas., et al. "Frequency and intensity noise in an injection-locked, solid-state laser" *Journal of the Optical Society of America*, Volume **12**, No. 2, February 1995, 328-334.
- 6 A. E. Siegman, *Lasers*, University Science, Mill Valley, CA, 1986
- 7 J. M. Eggleston, L. M. Frantz, and H. Injeyan, "Derivation of the Frantz-Nodvick Equation for Zig-Zag Optical Path, Slab Geometry Laser Amplifiers," *IEEE JQE, QE-25*, pp. 1855 (Aug. 1989)
- 8 J. A. Armstrong, N. Bloembergen, J. Ducuing and P. S. Pershan, "Interactions between light waves in a nonlinear dielectric," *Phys. Rev.* **127**, 1918-1939 (1962)
- 9 M. M.. Fejer, G. A. Magel, D.H. Jundt, and R.L. Byer, "Quasi-Phase-Matched Second Harmonic Generation: Tuning and Tolerances", *IEEE J. Quant. Elect.* Vol. **28**, No. 11, November 1992, pp. 2631-2654.
- 10 M. Yamada, N. Nada, M. Saitoh, and K. Watanabe, " First-order quasi-phase matched LiNbO₃ waveguide periodically poled by applying an external field for efficient blue second-harmonic generation, " *Appl. Phys. Lett.* **62**, p. 435-436, (1993)
- 11 L. E. Myers, G. Miller, R. C. Eckardt, M. M. Fejer, R. L. Byer "Quasi-Phasematched 1.064 μ m pumped optical parametric oscillator in bulk periodically poled LiNbO₃" post deadline paper presented at the Nonlinear Optics Conference, Kona, Hawaii July 1994.

- 12 L. E. Myers, R. C. Eckardt, M. M. Fejer, R. L. Byer, J. W. Pierce, and R. G. Beausoleil, "CW Diode Pumped Optical Parametric Oscillator in Bulk Periodically Poled LiNbO₃" Postdeadline paper Advanced Solid State Laser Conference, Memphis TN 1995.
- 13 L.E. Myers, R. C. Eckardt, M.M. Fejer, R.L. Byer, W.R. Bosenberg, J.W. Pierce, "Quasi-phase-matched optical parametric oscillators in bulk periodically poled LiNbO₃," J. Opt.Soc. Am. B, **12**, 2102-2116, (November 1995).
- 14 L. E. Myers, R. C. Eckardt, M. M. Fejer and R. L. Byer, "Multigrating quasi- phasematched optical parametric oscillator in periodically poled LiNbO₃" Opt Lett **21**, p 591-593, (1996)
- 15 R. G. Batchko, D. R. Weise, T. Plettner, G. D. Miller, M. M. Fejer, R. L. Byer, "Continuous-wave 532 nm pumped singly-resonant optical parametric oscillation in periodically poled lithium niobate," CLEO '97, Baltimore, MD (1997).
- 16 G. D. Miller, R. G. Batchko, W. M. Tulloch, D. R. Weise, M. M. Fejer, R. L. Byer, "42% efficient single-pass second harmonic generation in 5.3 cm long periodically poled LiNbO₃ producing 2.7 W of 532 nm light," Opt. Lett., to be published, (submitted July, 1997).

VI. Appendices - Reprints of Publications

R. J. Shine, jr., A. J. Alfrey, and R. L. Byer, "Conduction cooled, continuous wave, diode-laser-pumped Nd:YAG mini-slab laser," OSA Proceedings on Advanced Solid-State Lasers, T. Y. Fan and B. H. T. Chai, eds. (Optical Society of America, Washington, DC, 1994), vol. 20, pp. 2-5.

R. J. Shine, jr., A. J. Alfrey, and R. L. Byer, "40-W cw, TEM₀₀-mode, diode-laser-pumped, Nd:YAG miniature-slab laser," Optics Letters, **20**, pp. 459-461, (March 1, 1995).

R. J. Shine, Jr., A. J. Alfrey, and R. L. Byer, "A 40 W CW, TEM₀₀ Mode, Diode-Laser-Pumped, Nd:YAG Slab Laser," in *OSA Proceedings on Advanced Solid-State Lasers*, vol. 24, Bruce H. T. Chai and Stephen A. Payne, eds. (Optical Society of America, Washington, D.C., 1995), pp. 216-218.

R. J. Shine, Jr., A. J. Alfrey, and R. L. Byer, "A 40 W CW, TEM₀₀ Mode, Diode-Laser-Pumped, Nd:YAG Zig-Zag Miniature-Slab Laser," in *SPIE Proceedings on Solid State Lasers and Nonlinear Crystals*, vol. 2379 (SPIE, Washington, 1995) pp. 112-119.

T. Taira, T. Kobayashi, W. M. Tulloch and R. L. Byer, "Single Axial Mode Oscillation of a Coupled-Cavity Yb:YAG Laser," in *OSA TOPS on Advanced Solid-State Lasers*, Vol. 1, (Optical Society of America, Washington, DC, 1996) pp. 14-15.

L.E. Myers, W.R. Bosenberg, J.I. Alexander, M.A. Arbore, M.M. Fejer and R.L. Byer, "CW Singly-resonant Optical Parametric Oscillators Based on 1.064 mm-pumped Periodically Poled LiNbO₃," in *OSA TOPS on Advanced Solid-State Lasers*, 1996, Vol. 1, (Optical Society of America, Washington, DC, 1996) pp. 35-37.

W.R. Bosenberg, A. Dobershoff, J.I. Alexander, L.E. Myers, W.M. Tulloch and R.L. Byer, "cw singly-resonant optical parametric oscillator based on periodically-poled LiNbO₃," in *Conference on Lasers and Electro-Optics*, 1996 Technical Digest Series, Vol. 9 (Optical Society of America, Washington, DC, 1996), pp. 340-341

Conduction-Cooled, Continuous Wave, Diode-Laser-Pumped, Nd:YAG Mini-Slab Laser

R. J. Shine, Jr., A. J. Alfrey, and R. L. Byer

E. L. Ginzton Laboratory, Stanford University, Stanford, California 94305

Abstract

We have designed a low loss mounting scheme for zig-zag slab lasers. This scheme includes a Teflon[®] AF coating to protect the slab total internal reflection (TIR) surfaces. In addition, the slab is conduction cooled through a window to isolate the water flow from the slab surfaces. This design was initially tested on a line-pumped slab laser which operated with 5 watts of output power at a pump power of 28 watts. The laser operated in a TEM₀₀ mode at all powers. The low loss protective coating allowed this laser to operate on the lower gain line of Nd:YAG at 1.32, with 1.1 watt of output power at the same pump power. Since that time, a higher power laser has been built. This laser operates with a 20% slope efficiency, with an output power of 30 watts at a pump power of 160 watts.

Introduction

One of the goals of our laser development program is to design and build a laser that meets the specifications for the Laser Interferometer Gravity-Wave Observatory (LIGO) program.[1] The LIGO requirements include single-frequency, polarized, fundamental-mode output at high power (≈ 100 watts) in continuous-wave operation. In our effort to demonstrate such a laser, we have begun by building lasers in the 5 to 10 watt range to test design ideas before implementing them in the more complicated and expensive high power laser. In this paper we discuss the design and operation of a Nd:YAG, zig-zag slab laser pumped with 28 watts of diode-laser power. A novel feature of this laser is a low loss, low cost Teflon[®] AF polymer protective coating applied to the total internal reflection (TIR) surfaces of the slab laser material.[2] This coating

keeps the round-trip cavity losses low, allowing the laser to operate efficiently even with side-pumping. We have obtained 5 watts of output power at 1.06 μm in a TEM₀₀ mode. The threshold was 3.4 watts and the slope efficiency was 19% with a 4% output coupler. In addition, the low cavity losses allow the laser to operate on the lower gain line at 1.32 μm , although the efficiency suffers. We have obtained output powers up to 1.1 watt at 1.32 μm , again in a TEM₀₀ mode.

Laser Design

Many of the laser design choices are dictated by the application. We chose to fiber-couple the diode-laser pump sources to improve the system reliability. However, fiber-coupling reduces the brightness of the pump source and requires a side-pumped design. Our pump sources are Spectra Diode Labs SDL-3490-P5 diode lasers with 0.4 N.A., 400 μm core fibers.[3] We also chose to use a Brewster angle, zig-zag slab design over a rod for its greater thermal handling capabilities. In a true uniformly pumped zig-zag slab, the rectilinear geometry minimizes depolarization loss while the zig-zag optical path averages the thermal gradient to reduce thermal lensing.[4] In the past, most slab lasers were operated pulsed with a multi-transverse mode structure. The transverse mode structure filled the slab volume well and pulsed operation created high peak gains for efficient operation. In order to improve beam quality, unstable resonators can be used.[5] At high cw powers and in pulsed systems the gain is high enough to run an unstable resonator with a large mode to fill a large aspect ratio slab. At lower cw powers, between 3 and 20 watts, the gain is not high enough to run an unstable resonator effectively, so we could not operate a true zig-zag slab laser with uniform pumping. Instead, we chose to focus the pump power onto a narrow stripe along the slab. We achieved roughly 1:1

focusing of the pump fibers using two spherical $f/1$ lenses. This allowed us to run a stable cavity mode and thus to efficiently extract the pump power in a TEM_{00} mode. The slab was cooled through the large pumped surfaces, just as in a true zig-zag slab laser. However, in the side-pumped line design, there will be a cylindrical thermal lens and possibly some thermal aberrations in the non-zig-zag plane. The slab thickness was chosen to be roughly half an absorption depth to reduce the thermal gradient while absorbing a reasonable amount of the pump. The residual transmitted pump power was retroreflected using an $f/1$ mirror to refocus the pump for a second pass through the slab.

As mentioned, we built this 5 watt laser before building the high power diode-laser-pumped slab laser in order to test design ideas. Specifically, we investigated ideas for mounting and cooling the slab. We decided not to use direct water cooling at the slab surface for a few reasons although mostly because it is difficult to seal the Brewster-angle zig-zag slab laser with O-rings while not disturbing the TIR bounce at the surface, especially in the miniature slab laser we have built. Instead, we chose to directly conduction cool the slab through MgF_2 windows. Water flows behind this window to remove the heat, but does not interact with the slab TIR surface. MgF_2 is readily available, optically clear at the pump wavelength, easily polished, has a low refractive index of 1.37, a relatively high thermal conductivity of $21 \text{ W m}^{-1} \text{ K}^{-1}$ and is inexpensive.[6] The low refractive index is not necessary to preserve the TIR bounce in the slab since we applied a protective coating to the slab surface, but it does reduce Fresnel reflections of the pump light. In the future the windows could be AR coated to avoid reflection of the pump.

To preserve the TIR reflection in the zig-zag slab, we designed a simple, low cost coating. A hard SiO_2 coating a few microns thick has been used in the past for this purpose[7] but instead we used a Teflon[®] AF polymer recently developed by DuPont. The Teflon[®] AF polymer has all the advantages of Teflon[®] but is optically clear and is soluble in perfluorinated solvents.[2] To create the protective coating, we used a solution of the Teflon[®] AF polymer in a Fluorinert[®] solvent made by 3M.[8] The solution was applied to the TIR faces of the slab and the solvent was allowed to evaporate. This Teflon[®] AF coating is quite durable, we have noticed no degradation in laser power during use. In addition the coating can be removed simply by redissolving the Teflon[®] AF in the Fluorinert[®] solvent. The protective coating works well, giving a round-trip cavity loss between 1 and 1.7% as measured using the Findlay-Clay method.[9] This cavity loss includes TIR loss for 10 bounces in the slab, bulk scatter and absorption loss for a beam path of 2.7 cm in the gain

medium, residual depolarization loss, mirror scatter and clipping loss. A similar laser using Nd:YAG from the same source but without any protective coating has a measured cavity loss of 5.6%.[10] It is the low loss design of this laser which allows it to operate efficiently at $1.06 \mu\text{m}$ even in a side-pumped geometry. The low loss also allows the laser to operate on the lower gain $1.32 \mu\text{m}$ line, although with reduced efficiency due to the lower quantum defect and a lower output coupler value.

Experimental Results

A simple near-hemispherical cavity was used in all of the experiments described here. The curved mirror ($R = 1$ meter) was placed as close as possible to the gain medium while the flat mirror was located roughly 20 cm away. To characterize the laser performance at $1.06 \mu\text{m}$, we measured the output power as a function of input pump power, as shown in fig. 1. We obtained a maximum power of 4.8 watts. The threshold power was 3.4 watts and the slope efficiency was 19% with a 4% output coupler. Because of the standing-wave cavity design, the laser operates in several axial modes. Longitudinal-mode

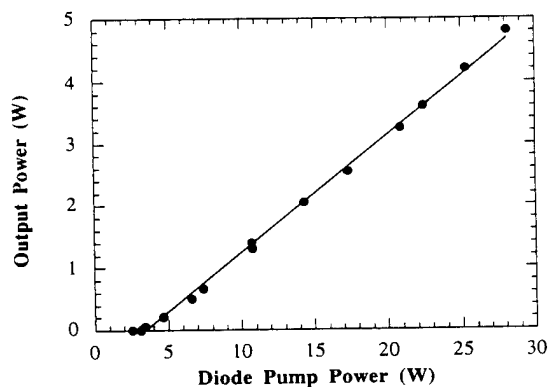

Figure 1. Diagram showing the output power at $1.06 \mu\text{m}$ vs. diode pump power. The slope efficiency was 19% with a threshold of 3.4 W.

beating was observed on an RF spectrum analyzer at the expected TEM_{00} mode spacing. No evidence of transverse-mode beating was observed within the experiment's dynamic range of 40 dB. Because of the Brewster angle slab design, the laser operates in a single polarization with a polarization ratio of greater than 500:1. Using a knife-edge to measure the beam waist, we find an M^2 of 1.07 in the horizontal zig-zag direction and 1.2 in the vertical direction. It is not surprising that the horizontal direction has a lower M^2 value since the zig-zag optical path averages out the

thermal distortion. The laser operated in a TEM₀₀ mode at all powers.

We also investigated operation of the laser at 1.32 μm by changing the cavity mirrors. The reflectivity of the mirrors were measured on a spectrophotometer. Both mirrors were coated for operation at 1.32 μm and were highly transmissive at 1.06 μm to prevent operation on this higher gain line. We confirmed that the output was indeed at the expected wavelength using an Ando optical multichannel analyzer. The output power versus pump power for the 1.32 μm laser is shown in fig. 2. A maximum power of 1.1 watt was obtained. With a 1.3% output coupler, the threshold was 7.25 watts and the slope efficiency was 5%. This is not the optimum output coupling for the laser but we were limited in our choice of optics at 1.32 μm . As before, the 1.32 μm laser operates in a TEM₀₀ mode at all powers. This was confirmed by observing the beat note on an InGaAs detector with response out to 1.6 μm .

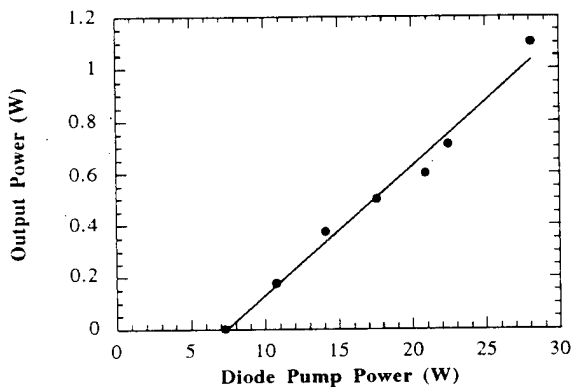

Figure 2. Plot showing the output power at 1.32 μm vs. diode pump power. The slope efficiency was 5% with a threshold of 7.25 W.

Recently, we have built a higher power laser using the laser mounting scheme developed at the lower powers reported above. Again, we apply a protective coating of Teflon[®] AF to the slab TIR surfaces and conduction cool these surfaces with a water cooled copper block. The pump fibers are held in this copper block using hypodermic tubes and are butted against a spacer without any focussing optics. The fibers are distributed to make the pumping as uniform as possible over the slab surface to take advantage of the slab design. To date we have only obtained preliminary results with this laser. The measured round trip cavity loss is 2.3% which demonstrates the effectiveness of the Teflon[®] AF coating. We have obtained 30 watts of output power

with a pump power of 160 watts. The threshold was 16 watts with a slope efficiency of 20%. The mode structure of the laser has not been determined but we believe we can obtain TEM₀₀ output without a significant decrease in output power.

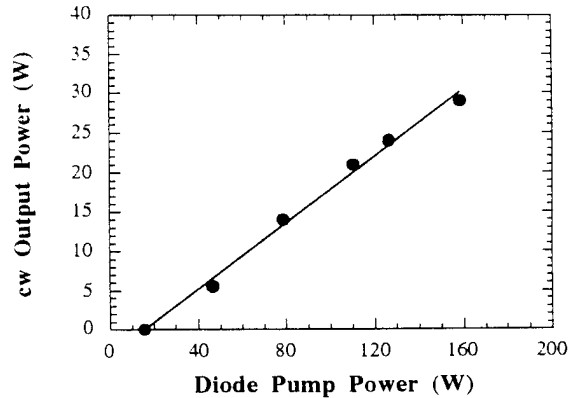

Figure 3. Plot showing the output power vs. diode pump power. The slope efficiency was 21% with a threshold of 16 W.

In conclusion, we have built and operated a 5 watt 1.06 μm and a 1 watt 1.32 μm , cw, TEM₀₀ mode, diode-laser pumped, Nd:YAG slab laser. We have developed a low loss, low cost Teflon[®] AF coating to protect the total internal reflection surfaces of the slab laser, resulting in efficient operation in a side-pumped design. The knowledge we have gained from this lower power laser has been applied to a high power, diode-laser-pumped slab laser which operates at the same slope efficiency with 30 watts of output power at a pump power of 160 watts.

Acknowledgments

The authors wish to thank Alex Farinas for useful discussions. This work was supported by DARPA through ARO contract #DAAL03-90-C-0026.

References

1. A. Abramovici, W. E. Althouse, R. W. P. Drever, Y. Gürsel, S. Kawamura, F. Raab, D. Shoemaker, L. Sievers, R. E. Spero, K. S. Thorne, R. E. Voght, R. Weiss, S. Whitcomb and M. E. Zucker, *Science*, **256**, 325 (1992).
2. Teflon[®] AF, DuPont product literature (DuPont Polymers, P.O. Box 80711, Wilmington, DE 19880-0711).
3. Spectra Diode Laboratory product information (80 Rose Orchard Way, San Jose, CA 95134-1356).

4. J. M. Eggleston, T. J. Kane, K. Kuhn, J. Unternährer and R. L. Byer, *IEEE J. Quantum Electron.*, **QE-20**, 289 (1984).
5. A. E. Siegman, *Lasers* (University Science, Mill Valley, CA, 1986).
6. Optovac product information (E. Brookfield Rd., N. Brookfield, MA 01535).
7. C. Lüchinger, H. von Arb, F. Studer and J. R. Unternährer, *Opt. Engineering*, **32**, 786 (1993).
8. Fluorinert[®] solvents, 3M product information (3M Industrial Chemical Products Division, St. Paul, MN 55144-1000).
9. D. Findlay and R. A. Clay, *Phys. Lett.*, **20**, 277 (1966).
10. A. D. Farinas, Y. Kaneda, E. K. Gustafson and R. L. Byer, *CLEO '93*, (Optical Society of America, Washington, D.C., 1993) paper CThR2.

40-W cw, TEM₀₀-mode, diode-laser-pumped, Nd:YAG miniature-slab laser

R. J. Shine, Jr., A. J. Alfrey, and R. L. Byer

Edward L. Ginzton Laboratory, Stanford University, Stanford, California 94305-4085

Received August 10, 1994

We have built a diode-laser-pumped Nd:YAG slab laser that emits 40 W of cw power in a TEM₀₀ mode and 72 W of power in multimode operation when pumped with 235 W. The slope efficiencies are 22% for TEM₀₀-mode operation and 36% for multimode operation. The laser uses a zigzag slab geometry to reduce thermally induced distortions and operates at less than one wave of distortion at the full pump power. A significant advantage of our design over those of previous slab lasers is a new Teflon AF protective coating on the slab total-internal-reflection surfaces, which greatly simplifies the mounting and cooling of the slab laser medium.

Gravitational-wave interferometric receivers and high-power resonant nonlinear optical interactions require an efficient laser that provides many tens of watts in a nearly diffraction-limited mode. Previous attempts to build high-power, high-beam-quality lasers have typically used a rod laser design, with either end or side pumping.^{1,2} However, at high powers thermal lensing, stress birefringence, and biaxial focusing degrade laser performance. The zigzag slab design is known to reduce thermally induced effects³ but has been avoided because of slab fabrication and mounting difficulties. In addition, the zigzag slab geometry typically produces a multimode rectangular output beam that is not useful for applications requiring high beam quality. In this Letter we describe a diode-laser-pumped, cw, Nd:YAG zigzag slab laser that efficiently produces a TEM₀₀ mode with a simple water-cooled laser head design. Although the slab laser design has been used successfully in diode-laser-pumped pulsed laser systems,^{4,5} this is to our knowledge the first implementation of a uniformly face-pumped, face-cooled, cw, diode-pumped slab laser.

The goal of our design is to produce a laser operating at many tens of watts with minimal thermal lensing and stress birefringence. By reduction of the thermal loading effects at these high pump powers, the laser should operate with good efficiency and reliability in a TEM₀₀ mode. By minimizing the thermal lensing, we can design a simple resonator that operates well into the stability region while still having a TEM₀₀-mode size large enough to extract the power efficiently. In addition, the laser head design is simple, making it easy to assemble and disassemble.

Figure 1 shows a schematic of the laser head. The Nd:YAG slab is mounted in an aluminum frame and sealed at both ends. We place the O-rings just as one would place O-rings on a rod with no care taken to locate the O-rings away from a bounce point since the slab is protected by a low-index coating. We insulate the top and bottom of the slab by placing gold-coated glass microscope slides in contact with the Nd:YAG slab. The glass slides are coated on the back with a thin RTV silicone layer for stress relief.

The last two sides of the frame contain the fiber pump modules. The Nd:YAG slab is water cooled with 2-mm-thick water channels flowing between the slab surfaces and the brass fiber holders. The water flows at a rate of 1 L/min, and the Reynolds number and flow geometry were selected to make the flow turbulent. The fibers are isolated from the water flow by a 0.5-mm antireflection-coated sapphire window glued onto the brass mount. The assembly of this laser head is simple and typically takes less than 10 min.

Compared with lamp pumping, diode-laser pumping offers high electrical-to-optical efficiency, long lifetimes, and good spectral overlap with the absorption bands of solid-state lasers.⁶ This last feature is especially useful because it reduces the thermal

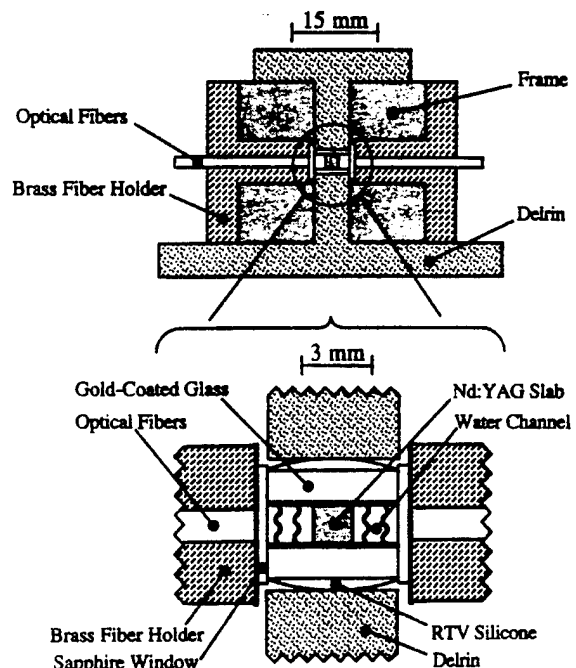

Fig. 1. Schematic of the laser head. The thick black lines on the glass slides and the brass fiber holders represent gold coatings for confining the pump light.

loading of the slab. In addition, we have chosen to use fiber-coupled diode lasers rather than bare diode bars.^{7,8} Although this reduces the overall system efficiency, it increases the reliability of the design as well as simplifying the engineering. The diode lasers can be mounted on a water-cooled block well away from the laser head, thus separating the heat loads. Two simple clamps hold all the fibers in the laser head assembly, reducing the laser head size and complexity. The pump sources for our laser are 25 Spectra Diode Laboratories SDL-3450-P5 fiber-coupled diode lasers. Each 600- μm , 0.4-N.A. fiber emits 9.5 W of power for a total of 235 W at the slab. An additional fiber-to-fiber junction to provide easy disassembly accounts for a 5% power loss from each diode laser.

The anticipated pump power levels and desired gain can be used to determine the slab dimensions. The slab cross-sectional area determines the laser gain, while the pump power per unit length is limited by stress fracture of the material. Other factors to consider include the thermal gradient created by the pump absorption, the Nd:YAG absorption depth, and resonator designs for efficient TEM₀₀-mode operation. Given these criteria, we chose a slab with a thickness of 1.7 mm, a width of 1.8 mm, and a center-line length of 58.9 mm. This length corresponds to 22 total-internal-reflection (TIR) bounces and is chosen to operate at 50% of the stress fracture limit at the full pump power of 235 W.⁹ Although we do not take full advantage of the slab design because of the small aspect ratio, we still minimize the effects of stress birefringence and thermal lensing and obtain a nearly diffraction-limited mode with good efficiency.

For the benefits of the slab design to be obtained, the laser gain medium must be efficiently and uniformly pumped. The interior surface of the brass fiber holder has been polished and gold coated. The fiber locations are chosen to increase both the reflectivity of the unabsorbed pump power from the opposite fiber holder and to increase the pump uniformity. The 2.5-mm space between the fiber ends and the slab face and the high N.A. of the fibers also act to improve the uniformity of the pump power deposition within the Nd:YAG slab. The glass insulator is gold coated to confine the pump light and increase the absorption by the Nd:YAG slab. We anticipated a minor cylindrical lens because of nonideal insulation on the top and bottom of the slab laser.

To overcome the difficulty of mounting a zigzag slab laser created by the TIR bounce points, we have developed a new coating for these surfaces.^{10,11} Previous workers have used dielectric coatings, typically SiO₂, as a protective coating.¹² However, these thick coatings can be difficult and expensive to apply. The coatings we use is a new fluoropolymer, Teflon AF 1600, developed by duPont. This polymer is optically clear throughout the visible and near-IR regions of the spectrum, has a refractive index near 1.3, and is soluble in perfluorinated solvents. We apply this protective layer to a cleaned Nd:YAG slab surface by painting the surface with the Teflon AF solution. The solvent evaporates within a few minutes, leaving a protective coating 3–15 μm thick, depending on the

initial concentration. This coating prevents evanescent wave coupling at the TIR interface and permits direct water cooling of the zigzag slab without wave-front distortion. It also eliminates the need to locate O-rings away from TIR bounce points. In addition, the coating appears durable; we have noticed no degradation in laser operation even though the Teflon AF-coated slab has been continuously submerged in cooling water. During the optimization of the laser head, the Teflon AF coating occasionally had higher losses than expected. When this happens, the laser head is disassembled and the slab is recoated. Complete disassembly, cleaning, recoating of the slab, and reassembly can be done in less than an hour. Finally, this coating introduces minimal loss at the TIR bounces; typical losses are 0.1–0.2% per bounce.

To test the effectiveness of our cooling design, we built a He-Ne interferometer around the slab laser head and counted fringes as the pump power was varied. The interferometer also allowed us to measure any thermal nonuniformity by observing the curvature of the fringe pattern. The fringes for the unpumped slab are flat to better than 1/10th wave and demonstrate that there is no net polishing error or mounting stress. There is a minor cylindrical lens created by the nonideal insulation. However, even at the full pump power, the fringe curvature is less than 1 wave of distortion. This curvature corresponds to a weak cylindrical lens of approximately 1-m focal length, which is easily compensated by the resonator design.

The laser was initially tested with a short confocal cavity. This cavity consisted of a 20-cm radius-of-curvature highly reflecting mirror placed 2 cm from one slab end and a flat 21% output coupler placed 11 cm from the opposite mirror. We calculated the diode-laser input power by monitoring the current to all 25 diode lasers and converting it to optical power using previous calibration measurements. At a pump power of 235 W, the zigzag slab laser emitted 72 W of power in a square, multimode beam. The optical-to-optical slope efficiency was 36% with a threshold of 30 W.

The laser was then operated in a TEM₀₀-mode configuration. We obtained the best performance by using a three-mirror folded cavity, as shown in Fig. 2. The asymmetric thermal lens is compensated by the astigmatism from an off-axis concave mirror. A 20-cm radius-of-curvature mirror was chosen to dominate the thermal lensing in the cavity, and the fold angle necessary to produce TEM₀₀-mode operation at full power was 45°. The mode size in the Nd:YAG slab is 500 μm and can be changed by small displacements in the short, 13-cm leg. It is adjusted so that clipping around the Nd:YAG slab

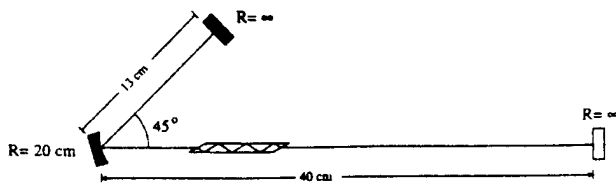

Fig. 2. Cavity design for TEM₀₀-mode operation.

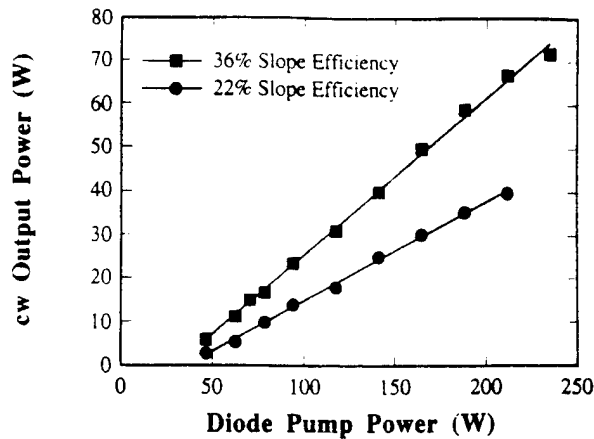

Fig. 3. Input-versus-output curve for multimode (squares) and TEM₀₀-mode (circles) operation.

prevents higher-order modes from oscillating. We confirmed TEM₀₀-mode operation by displaying the beat note from a fast photodetector on a spectrum analyzer as well as monitoring a portion of the output beam with a scanning slit. At most power levels, 55% of the multimode power could be obtained in a TEM₀₀ mode by appropriate cavity adjustment. We obtained 40 W of power in a TEM₀₀ mode at a pump power level of 212 W. The slope efficiency for TEM₀₀-mode operation was 22%. Figure 3 shows the Nd:YAG cw output power versus diode-laser input power for both multimode and TEM₀₀-mode operation. The M^2 value was measured with the knife-edge technique and was found to be less than 1.3 in both directions. The output is polarized as a result of the Brewster slab faces, with a polarization ratio of better than 100:1.

In the future we plan to convert the standing-wave cavity to a ring cavity and injection lock the laser to obtain stable, single-frequency operation.¹³ The laser can then be used as a source for nonlinear optics experiments, which may include resonant doubling to the green, pumping a degenerate optical parametric oscillator to the mid-IR, and gravitational-wave interferometry studies.

In summary, we have built and demonstrated a zigzag slab laser that emits a power of 72 W cw multimode when pumped with 235 W and a power of 40 W TEM₀₀ when pumped with 212 W of diode-laser power. We obtained reasonable efficiency for the side-pumped slab design by confining the pump power within a gold-coated box around the slab. This also created a uniform thermal loading profile in the slab laser and contributed to the good fringe pattern. The mounting and cooling problems of the slab laser design were overcome by development of a new coating technique to protect the slab TIR surfaces.

This simplified the laser head design and allowed us to design a simple water-cooled structure with less than one wave of distortion at full pump powers of 235 W. The slightly nonideal loading and cooling of the slab laser created a minor cylindrical thermal lens that is compensated by an off-axis concave mirror. Because of the thermal handling benefits of the slab laser design, this laser can be scaled to higher output powers with appropriate scaling of the laser gain medium.

The authors acknowledge useful and interesting discussions with Alex Farinas and Eric Gustafson. This work was supported by U.S. Army Research Office grant DAAH04-94-6-0019.

References

1. S. C. Tidwell, J. F. Seamans, and M. S. Bowers, *Opt. Lett.* **18**, 116 (1993).
2. D. Golla, S. Knoke, W. Schöne, H. Zellmer, A. Tünnermann, and H. Schmidt, in *Conference on Lasers and Electro-Optics*, Vol. 8 of 1994 OSA Technical Digest Series (Optical Society of America, Washington, D.C., 1994), p. 282.
3. J. M. Eggleston, T. J. Kane, K. Kuhn, J. Unternahrer, and R. L. Byer, *IEEE J. Quantum Electron.* **QE-20**, 289 (1984).
4. B. J. Comaskey, R. Beach, G. Albrecht, W. J. Benett, B. L. Frietas, C. Petty, D. VanLue, D. Munding, and R. W. Solarz, *IEEE J. Quantum Electron.* **28**, 992 (1992).
5. R. J. St. Pierre, H. Injeyan, R. C. Hilyard, M. E. Weber, J. G. Berg, M. G. Wickham, C. S. Hofer, and J. P. Machan, *Proc. Soc. Photo-Opt. Instrum. Eng.* **1865**, 2 (1993).
6. J. G. Endriz, M. Vakili, G. S. Browder, M. deVito, J. M. Haden, G. L. Harnagel, W. F. Plano, M. Sakamoto, D. F. Welch, S. Willing, D. P. Worland, and H. C. Yao, *IEEE J. Quantum Electron.* **28**, 952 (1992).
7. J. Berger, D. F. Welch, W. Streifer, D. R. Scifres, N. J. Hoffman, J. J. Smith, and D. Radecki, *Opt. Lett.* **13**, 306 (1988).
8. R. L. Byer, *Science* **239**, 742 (1988).
9. W. F. Krupke, M. D. Shinn, J. E. Marion, J. A. Caird, and S. E. Stokowski, *J. Opt. Soc. Am. B* **3**, 102 (1986).
10. R. J. Shine, Jr., A. J. Alfrey, and R. L. Byer, in *Digest of Conference on Advanced Solid-State Lasers* (Optical Society of America, Washington, D.C., 1994), p. 60.
11. I. M. Thomas and J. H. Campbell, in *1991 Inertial Confinement Fusion Annual Report* (Lawrence Livermore National Laboratory, Livermore, Calif., 1991), p. 49.
12. L. E. Zapata, K. R. Manes, D. J. Christie, J. M. Davin, J. A. Blink, J. Penland, R. Demaret, and G. Dallum, *Proc. Soc. Photo-Opt. Instrum. Eng.* **1223**, 259 (1990).
13. A. D. Farinas, E. K. Gustafson, and R. L. Byer, *Opt. Lett.* **19**, 114 (1994).

40 W CW, TEM₀₀ Mode, Diode-Laser-Pumped, Nd:YAG Slab Laser

R. J. Shine, Jr., A. J. Alfrey, and R. L. Byer

E. L. Ginzton Laboratory, Stanford University, Stanford, California 94305

Abstract

We have built a zig-zag slab laser that emits 40 W cw in a TEM₀₀ mode and 72 W in multimode operation when pumped with 235 W. In addition, we have recently injection-locked the laser to obtain single frequency operation at an output power of 20 W when pumped with 165 W.

Introduction

Gravitational-wave interferometric receivers and high-power resonant non-linear optics require an efficient laser that provides many tens of watts in a nearly diffraction-limited mode. At these high power levels, thermal lensing, stress birefringence and biaxial focusing can degrade laser performance. The zig-zag slab design is known to reduce thermally induced effects,[1] but has been avoided due to slab fabrication and mounting difficulties. In addition, the zig-zag slab geometry typically produces a multimode rectangular output beam which is not useful for applications requiring high beam quality. In this letter we describe a diode-laser-pumped, cw, Nd:YAG zig-zag slab laser that efficiently produces a TEM₀₀ mode with a simple water-cooled laser head design. The laser emits 40 W cw in a TEM₀₀ mode when pumped with 212 W and 72 W in multimode operation when pumped with 235 W. The threshold was 30 W with a slope efficiency of 22% for TEM₀₀ mode operation and 36% for multimode operation.

Laser Design

Many of the laser design choices are dictated by the application. We chose diode lasers as the pump

sources for their high electrical-to-optical efficiency, long lifetimes, and good spectral overlap with the absorption bands of solid-state lasers. In addition, we chose to use fiber-coupled diode lasers rather than bare diode bars. Although this reduces the overall system efficiency, it increases the reliability of the design as well as simplifying the engineering. The pump sources for our laser are twenty five SDL-3450-P5 fiber-coupled diode lasers (SDL, Inc.). Each 600 μm , 0.4 numerical aperture (N.A.) fiber emits 9.5 W for a total of 235 W at the slab. An additional fiber to fiber junction that provides easy disassembly accounts for a 5% power loss from each diode laser.

We have chosen to use a zig-zag slab laser design because of the thermal handling benefits of this design at high power.[1] To obtain these benefits, it is critical to pump and cool the two total internal reflection (TIR) surfaces as uniformly as possible. We have attempted to achieve uniform thermal loading in the slab by surrounding the Nd:YAG slab with a "gold box." The fiber holders are gold coated and the fibers are staggered to increase the reflectivity of the unabsorbed pump light. In addition, the glass insulators placed in contact with the slab are gold coated. The Nd:YAG slab is water cooled with a flow rate of 0.5 liters per minute. We found that water cooling was necessary to increase the heat transfer coefficient from the slab. The Nd:YAG slab has a thickness of 1.7 mm, a width of 1.8 mm, and a centerline length of 58.9 mm. We chose these dimensions as a compromise between pump absorption, thermal gradient, stress fracture limit and gain while keeping in mind resonator designs for efficient TEM₀₀ mode operation. We have tested the effectiveness of our laser head design by viewing fringes in a HeNe interferometer. The fringes for the unpumped slab are flat to better than 1/10th wave and demonstrate that there is no net polishing error or mounting stress. When pumped, there is a minor

cylindrical lens created by the non-ideal insulation. However, even at the full pump power, the fringe curvature is less than 1 wave. This curvature corresponds to a weak cylindrical lens of approximately 1 meter focal length which is easily compensated in the resonator design.

We have developed a new coating that allows direct contact with the TIR surfaces without disturbance to the intracavity wavefront.[2,3] Previous workers have used dielectric coatings, typically SiO_2 , as a protective coating. However, these thick coatings can be difficult and expensive to apply. The coating we use is a new fluoropolymer, Teflon AF[®]1600, developed by duPont. This coating prevents evanescent wave coupling at the TIR interface and permits direct water cooling of the zig-zag slab without wavefront distortion. It also eliminates the need to locate O-rings away from TIR bounce points. In addition, the coating appears durable; we have noticed no degradation in laser operation even though the Teflon-AF[®]-coated slab has been continuously submerged in cooling water. Finally, this coating introduces minimal loss at the TIR bounces; typical loss numbers are between 0.1 to 0.2% per bounce.

Experimental Results

The laser head was initially tested within a short confocal cavity for multimode operation. This cavity consisted of a 20 cm radius of curvature HR mirror placed 2 cm from one slab end and a flat 21% output coupler placed 11 cm from the opposite mirror. The diode laser input power was calculated by monitoring the current to all 25 diode lasers and converting to optical power using previous calibration measurements. At a pump power of 235 W, the zig-zag slab laser emitted 72 W in a square, multimode beam. The optical-to-optical slope efficiency was 36% with a threshold of 30 W.

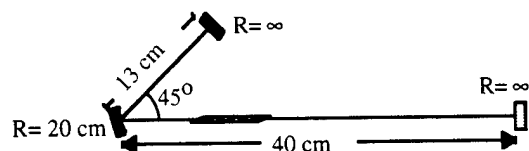

Figure 1. Diagram of laser cavity for TEM₀₀ mode operation.

The laser was then operated in a TEM₀₀ mode configuration. The best performance was obtained by using a three mirror folded cavity as shown in figure 1. The asymmetric thermal lens is compensated by using the astigmatism from off-axis incidence on a concave mirror. A 20 cm radius of curvature mirror was chosen to dominate the thermal lensing in the cavity and the fold angle necessary to obtain TEM₀₀ mode operation at full power was 45°. The mode radius in

the Nd:YAG slab is 500 μm and can be changed by small displacements in the short 13 cm leg. It is adjusted so that clipping around the Nd:YAG slab prevents higher order modes from oscillating. TEM₀₀ mode operation was confirmed by displaying the beat note from a fast photodetector on a spectrum analyzer as well as monitoring a portion of the output beam with a scanning slit. At most power levels, 55% of the multimode power could be obtained in a TEM₀₀ mode by appropriate cavity adjustment. We obtained 40 W in a TEM₀₀ mode at a pump power level of 212 W. The slope efficiency for TEM₀₀ mode operation was 22% with a threshold of 30 W. Figure 2 shows the diode laser input power versus Nd:YAG cw output power for both multimode and TEM₀₀ mode operation. The M² value was measured using the knife edge technique and was found to be less than 1.3 in both directions. The output is polarized due to the Brewster slab faces with a polarization ratio better than 100:1.

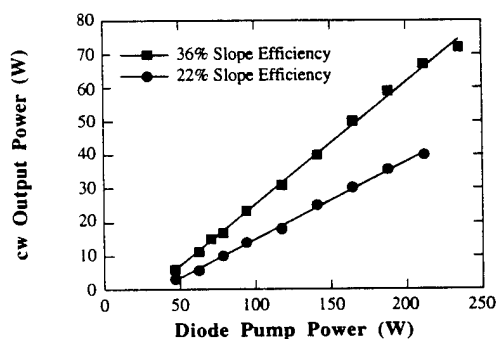

Figure 2. Input vs. output curve for multimode (squares) and TEM₀₀ mode (circles) operation.

Our applications for this laser require stable, single frequency operation. We have converted the laser to a ring cavity and injection locked the laser using the Pound-Drever-Hall technique.[4,5] We used a Lightwave Electronics model #122-1064-300-F laser as the master laser with the slave laser cavity length stabilized with feedback to a piezo-mounted mirror. This mirror has a resonant frequency of 30 kHz and only this one moderately fast piezo was needed for stable locking. To compensate for slow temperature drifts in the cavity we built a feedback circuit to control the master oscillator temperature. This circuit uses the pole in the Lightwave Electronics laser temperature response near 1 Hz and does not affect the much faster cavity servo lock used in the FM sideband technique. Single frequency operation was confirmed by using a scanning confocal interferometer, as shown in figure 3. Using both feedback circuits we have observe stable locking over periods greater than an hour at 20 watts of output power. In the future we plan to use the injection locked laser as a source for non-

linear optics experiments, which may include resonant doubling to the green, pumping a degenerate OPO to the mid IR or gravitational-wave interferometry studies.



Figure 3. Confocal interferometer trace displaying single frequency output. Upper line displays ramp voltage to interferometer.

Conclusion

In summary, we have built and demonstrated a zig-zag slab laser that emits 72 W cw multimode when pumped with 235 W or 40 W TEM₀₀ when pumped with 212 W of diode laser power. In addition, we have injection locked this laser to obtain 20 W of single frequency output when pumped with 165 W. Reasonable efficiency for the side-pumped slab design was obtained by confining the pump power within a gold-coated box around the slab. This also created a very uniform thermal loading profile in the slab laser and contributed to the good fringe pattern. The mounting and cooling problems of the slab laser design were overcome by developing a new coating technique to protect the slab TIR surfaces. This simplified the laser head design and allowed us to design a simple water-cooled structure with less than one wave of distortion at full pump powers of 235 W. The slightly non-ideal loading and cooling of the slab laser created a minor cylindrical thermal lens which is compensated by off axis incidence on a concave mirror. Because of the thermal handling benefits of the slab laser design, this laser can be scaled to higher output powers with appropriate scaling of the laser gain medium.

Acknowledgments

The authors wish to thank Alex Farinas and Eric Gustafson for useful and interesting discussions. This work was supported by ARO grant #DAAH04-94-6-0019.

References

1. J. M. Eggleston, T. J. Kane, K. Kuhn, J. Unternahrer, and R. L. Byer, IEEE J.Q.E **QE-20**, 289 (1984).
2. R. J. Shine Jr., A. J. Alfrey, and R. L. Byer, in *Advanced Solid-State Lasers*, Technical Digest, (Optical Society of America, Washington, DC, 1994) p. 60.
3. I. M. Thomas and J. H. Campbell, in *1991 Inertial Confinement Fusion Annual Report* (Lawrence Livermore National Laboratory, Livermore, CA) p.49.
4. R. W. P. Drever, J. L. Hall, F. V. Kowalski, J. Hough, G. M. Ford, A. J. Munley, and H. Ward, Appl. Phys. B **31**, 97 (1983).
5. C. D. Nabors, A. D. Farinas, T. Day, S. T. Yang, E. K. Gustafson and R. L. Byer, Opt. Lett. **14**, 1189 (1989).

A 40 W cw, TEM₀₀ mode, diode-laser-pumped, Nd:YAG zig-zag miniature-slab laser

R. J. Shine Jr., A. J. Alfrey and R. L. Byer

E. L. Ginzton Laboratory, Stanford University
Stanford, CA 94305

ABSTRACT

We have built a cw, diode-laser-pumped, Nd:YAG slab laser that emits 72 W of multimode power when pumped with 235 W, or 40 W of TEM₀₀ power when pumped with 212 W of diode laser power. The slope efficiencies are 36% for multimode operation and 22% for TEM₀₀ mode operation. The laser uses the zig-zag slab geometry to reduce the thermal effects associated with high power operation, resulting in less than one wave of distortion at the full pump power. Reasonable efficiency for the side-pumped slab design was obtained by confining the pump power within a gold-coated box which surrounds the slab. TEM₀₀ mode operation was obtained in a simple three-mirror folded cavity. The Nd:YAG slab acted as an aperture in the cavity and the astigmatism due to off axis incidence on a curved mirror corrected for a minor 1 meter cylindrical thermal lens. A significant advantage of our design over previous slab lasers is a new Teflon AF[®] protective coating on the slab total internal reflection surfaces which greatly simplifies the mounting and cooling of the slab laser medium.

2. INTRODUCTION

Gravitational-wave interferometric receivers and high-power resonant non-linear optical interactions require an efficient laser that provides many tens of watts cw in a nearly diffraction-limited mode.¹ Previous attempts to build diode-laser-pumped high power cw lasers with high beam quality have typically used a rod laser design, with either end- or side-pumping.^{2,3} However, at high powers thermal lensing, stress birefringence and biaxial focusing degrade laser performance.⁴ The zig-zag slab design is known to reduce thermally induced effects,⁵ but has been avoided because of slab fabrication and mounting difficulties. In addition, most zig-zag slab geometry lasers are designed to produce high power but in a multimode rectangular output beam that is many times diffraction-limited. In this paper we describe a diode-laser-pumped, cw, Nd:YAG zig-zag slab laser that efficiently produces a TEM₀₀ mode with a simple water-cooled laser head design. Although the slab laser design has been used successfully in diode-laser-pumped, pulsed laser systems,^{6,7} this is the first implementation of a uniformly face-pumped, face-cooled, cw, diode-pumped slab laser.

The goal of our design is to produce a laser operating at several tens of watts with minimal thermal lensing and stress birefringence. By minimizing the thermal lensing, a simple resonator can be designed which operates well inside the stability region while still having a TEM₀₀ mode size large enough to efficiently extract the power. Reducing the thermally induced stress birefringence will reduce cavity losses for the linearly polarized beam and improves the efficiency in a TEM₀₀ mode. In addition, the laser head design is simple, making it easy to assemble and disassemble.

3. LASER DESIGN CHOICES

We chose to use diode lasers as the pump source. Compared to lamp-pumping, diode laser pump sources offer high electrical-to-optical efficiency, long lifetimes, and good spectral overlap with the absorption bands of solid-state lasers.⁸ The narrow emission spectra of the diode lasers is also useful in high power laser engineering since it reduces the thermal loading of the slab. The emission wavelength of the diode laser can be tuned to the most efficient absorption band of the laser material, reducing the pump energy delivered to non-radiative transitions and hence the overall thermal loading of the slab. In addition, we have chosen to use fiber-coupled diode lasers rather than bare diode bars.^{9,10} Although this reduces the overall system efficiency, it increases the reliability of the design as well as simplifying the engineering. The use of multiple pump sources provides a soft failure mode. If a single diode fails, the power will drop by a fraction, but the laser will remain in operation. Fiber coupling allows this failed diode to be replaced without disassembly of the laser head by either recoupling the fiber to a working diode or turning on a reserve diode to return the output power to the previous level.¹¹ In this way the laser could operate almost continuously with scheduled maintenance to replace failed diodes. Engineering of the system is simplified by mounting the diode lasers well away from the laser head, thus separating the heat loads. In our system, each

diode is individually mounted on a thermo-electrically controlled (Peltier cooler) copper plate and is temperature tuned to match the 809 nm absorption line in Nd:YAG. Waste heat is removed from the diode plates by water cooling. We have noticed that the laser output power in our system is relatively insensitive to the actual diode temperature to within a few degrees. For this reason, it is possible to consider removing the thermo-electric coolers from the system to improve the overall electrical efficiency. In a system using a large number of diode lasers, the diode lasers could be binned into groups of 5 to 10 based on their operating temperature. The water temperature for each bin of diode lasers could be used to control the diode laser wavelength. Fiber coupling also simplifies the laser head design since no imaging or steering optics are needed to deliver the pump power to the gain medium. Two simple clamps hold all the fibers in the laser head assembly, creating a compact and simple laser head. The pump sources for our laser are twenty five SDL-3450-P5 fiber-coupled diode lasers (SDL, Inc.).¹² Each 600 μm core, 0.4 numerical aperture (N.A.) fiber emits 9.5 watts for a total of 235 watts at the slab. An additional fiber to fiber junction to provide easy disassembly accounts for a 5% power loss from each diode laser. At the beginning of this project, the diode laser cost made this project prohibitively expensive. However, during the three year course of this project, the cost of the diodes has been reduced by a factor of four while the output power has doubled. Even at this point the diode lasers remain a major cost of the system. After removing diode lasers which failed during a 24 hour burn-in performed under our supervision, this set of 25 diode lasers has operated reliably for a few hundred hours. Recently, though, we had our first diode laser failure. Assuming a binomial distribution of independent sources, the projected lifetime of a single diode laser based on this one failure is in the neighborhood of 7500 hours.

With a total diode laser pump power of 235 W available, thermal issues dominate the laser engineering. At high pump powers, thermal lensing and stress birefringence become significant problems in rod laser designs, using either end- or side-pumping. It is possible to compensate for these problems. Thermal lensing is the easiest problem to compensate, especially if the rod is uniformly pumped throughout its volume and uniformly cooled from its side. For example, the rod can be ground with concave ends to compensate for the thermal lensing at a fixed operating point.¹³ However, since most end-pumped designs do not pump with a uniform top-hat profile but rather with a gaussian profile to improve the pump and signal overlap, there will be higher order aberrations to the thermal lensing. Polishing concave ends onto the rod can make the laser more sensitive to these thermal aberrations induced in the rod. To avoid this problem, others have ground convex curvature onto the rod to dominate any thermal lensing.¹⁴ In this design, the thermal lensing becomes a small perturbation on top of the convex curvature and reduces the effect of thermal distortions. However, both these designs compensate the thermal lensing at a fixed point. Careful resonator design can reduce the sensitivity of the laser to the variations in rod thermal lensing. An example of this is the dynamically stable resonator where the mode volume in the rod is kept under control by appropriate choice of mirror curvatures.¹⁵ Similarly, it is possible to compensate for the stress birefringence by using a dual rod with a quartz rotator placed between the rods.¹⁶ Assuming both rods are pumped identically, the thermally induced birefringence and bifocusing can be canceled by rotating the polarization of all rays by 90°. In practice at moderate power, this design has been used to reduce depolarization losses from over 6% to below 0.2%.² As the power is increased, this compensation may not work as well as pump differences in the rods become more significant. The ultimate limit to end pumping is stress fracture of the rod. This depends critically on the cooling mechanism and pump distribution. For a side cooled design, a pump power of 60 W has fractured a rod, while with face cooling as much as 140 W has been applied to a single end.^{2,17} Near the stress fracture limit, it is difficult to obtain a diffraction-limited beam without going to extreme lengths to compensate for these various thermal distortions. Stress fracture related issues are less severe in a side-pumped rod since the power density per unit length can be reduced by distributing the pump power over a longer length. However, the problems of thermal lensing and stress birefringence are not avoided because these effects are caused by the cylindrical geometry of the gain medium and, in fact, thermal lensing is independent of length.¹⁸ Nevertheless, it is possible to avoid all of these problems to first order by using a zig-zag slab geometry.⁵

We chose to use a Brewster-end, zig-zag slab design.^{5,19} Stress-induced biaxial focusing and birefringence can be eliminated by using a rectilinear rather than a cylindrical geometry and if the slab is pumped and cooled uniformly on the correct surfaces. If the rectilinear slab is both uniformly pumped and cooled on two opposite surfaces, a one dimensional thermal profile is created and the isotherms and stress tensor remains aligned with the rectilinear axes of the slab. A linearly polarized signal beam experiences no birefringence effects or depolarization if it is aligned along one of the rectilinear axes, as it is in a Brewster-end design. In addition, the zig-zag optical path compensates for thermal lensing. The signal beam is confined by total internal reflection as it zig-zags across the thermal gradient in the slab. Since all portions of the signal beam experience the same thermal environment as it travels this zig-zag path, thermal lensing effects are avoided. We chose the geometry of the slab to have a straight resonator structure (zero angle between the ray outside the slab and the long axis of the

slab) with Brewster angle incidence. With these constraints and the choice of Nd:YAG as the slab material due to its high thermomechanical properties, the apex angle and internal bounce angle of the slab are completely determined, 28.8° and 32.4° respectively.¹⁹ Since these angles are not identical, there will be unfilled regions of the slab. Since the apex angle is less than the internal bounce angle, these unfilled regions occur at the entrance and exit faces of the slab reducing the useful aperture. Although the full slab is not accessible, rays that enter near the slab apex strike the entrance face after being totally internally reflected, a beam filling the useful aperture of the slab will sweep out the slab volume efficiently by double passing all points in the slab except those near the apex. This "unity fill factor" can make maximum use of the pumped region. In this design, it is important to avoid pumping within one slab width of the slab apex region to avoid end effects.²⁰ The slab apex is easily deformed if pumped, and this deformation can aberrate the beam. Recent designs have used AR-coated blunted slabs to avoid end effects as well as for other reasons.^{6,7} However, the Brewster-ended design does not need dielectric coatings on the entrance and exit faces and is less likely to suffer from parasitic oscillations. As a final note, the benefits of the zig-zag slab design depend critically on uniformly pumping and cooling the TIR surfaces and adequately insulating the unpumped surfaces to minimize thermal effects and beam distortion.

4. LASER DESIGN

The anticipated pump power levels and desired gain can be used to determine the slab dimensions. The slab cross sectional area determines the laser gain while the pump power per unit length is limited by stress fracture of the material and the slab aspect ratio. In most zig-zag slab designs, one wants to increase the slab aspect ratio, the width to thickness ratio, as much as possible since this more nearly approximates a semi-infinite slab and improves the thermal handling characteristics. In addition, this increases the cooling area of the slab and increases the pump power limit per unit length. However, since our system is to operate cw in a TEM₀₀ mode, we must make some design compromises. The gain of the cw system is too low to operate as an unstable resonator efficiently.²¹ This restricts our choice of slab cross section since we cannot use an unstable resonator to extract a large mode volume. In addition, we cannot use phase conjugate optics such as SBS cells to correct any phase aberration caused by the thermal load.⁷ Losses must be minimized in our cw system and it is difficult to find a phase conjugate system with near 100% reflection efficiency that works in the near-IR. For these reasons, we planned to use a stable resonator geometry. To avoid working near the edge of stability with relatively small resonators under 1 meter in length, we are limited to resonator modes smaller than 600 μm . To minimize diffraction effects while still extracting a significant portion of the pump energy the slab aperture should be roughly 3 to 4 times the mode radius.²² The correct slab thickness is critical to managing the thermal gradient in the slab. A thin slab reduces the thermal gradient but also reduces the amount of pump power absorbed. By designing a reflecting geometry to double pass the pump light, the pump absorption can be increased without increasing the thermal gradient significantly. We chose a slab thickness of 1.7 mm such that a double pass was roughly one absorption depth for our diode-laser pump sources. Since we anticipated a slight cylindrical lens due to imperfect insulation on the top and bottom of the slab, we chose a slab width of 1.8 mm such that a simple resonator would clip equally in both directions while the slab acted as an aperture. The slab length does not affect the gain, so a long slab is favorable to reduce the chance of stress fracture. However, crystal scatter and absorptions losses do increase with length while the fabrication of the slab becomes more difficult. We chose a slab length such that the full pump power would be 50% of the stress fracture limit.²³ This length of 58.9 mm represents 22 TIR bounces in the slab. With this number of bounces, it is important to minimize the loss associated with each TIR bounce. Although this slab design does not take full advantage of the slab design because of the near unity aspect ratio, it minimizes the effects of stress birefringence and thermal lensing, and results in a nearly diffraction-limited TEM₀₀ mode output with good slope efficiency.

Careful thought must be given to the mounting problems of the zig-zag slab design. The surfaces which serve to confine the signal beam by total internal reflection are the same surfaces that are pumped and cooled. It is important to choose a mounting design where the signal TIR is not affected by the cooling mechanism. At high thermal loads, water cooling will provide a very high heat transfer coefficient to remove the waste heat. Turbulent water can increase the heat transfer coefficient by as much as a factor of five,²⁴ but can create phase distortions on the laser beam by coupling to the evanescent wave. Previous workers have avoided this problem by depositing dielectric coatings, such as SiO₂, on the TIR surfaces.²⁵ However, these thick coatings can be difficult and expensive to apply. We have developed a new coating technique based on a new fluoropolymer, Teflon AF[®] 1600, developed by DuPont.²⁶ This polymer is optically clear throughout the visible and near IR regions of the spectrum, has a refractive index near 1.3, and is soluble in perfluorinated solvents.²⁷ We apply this protective layer to a cleaned Nd:YAG slab surface by painting the surface with the Teflon AF[®] solution. The solvent evaporates within a few minutes, leaving a protective coating from 3 to 15 μm thick, depending on the

initial concentration. This coating prevents evanescent wave coupling at the TIR interface and permits direct water cooling of the zig-zag slab without wavefront distortion. It also eliminates the need to locate O-rings away from TIR bounce points when mounting the slab. In addition, the coating appears durable; we have noticed no degradation in laser operation even though the Teflon-AF[®]-coated slab has been continuously submerged in cooling water for months. During the optimization of the laser head, the Teflon AF[®] coating occasionally has had higher losses than expected. When this happens, the laser head is disassembled and the slab is recoated. Complete disassembly, cleaning, recoating of the slab, and reassembly can be done in less than an hour. Finally, this coating introduces minimal loss at the TIR bounces; typical loss numbers are between 0.1 to 0.2% per bounce.

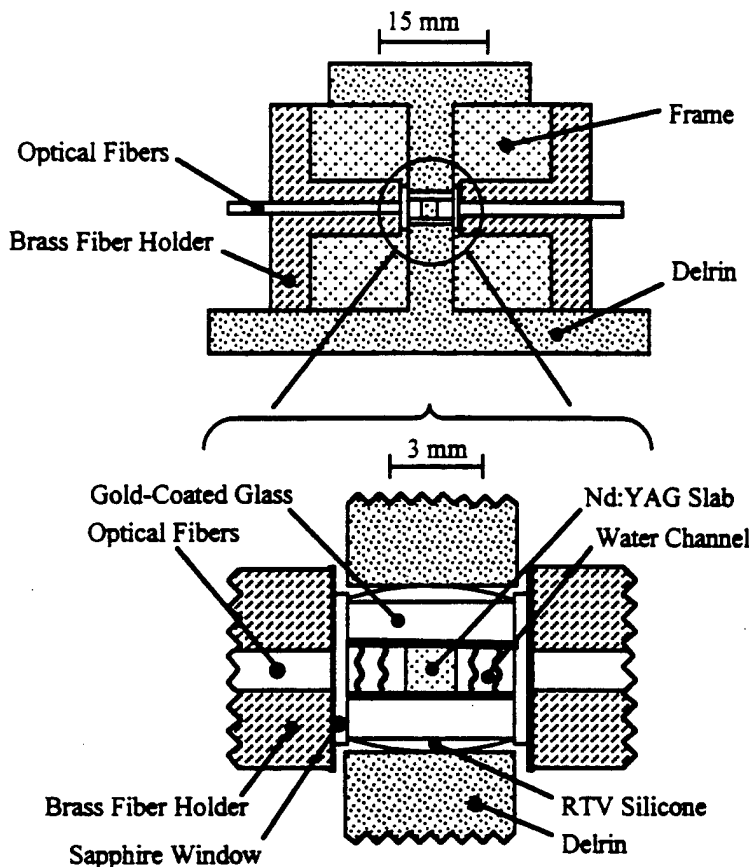

Figure 1. Schematic of laser head. The thick black lines on the glass slides and brass fiber holders represent gold coatings to confine the pump light.

has been polished and gold coated to reflect any unabsorbed pump radiation. The fibers positions are staggered in this brass mount both transversely to increase the uniformity of the pump distribution incident on the slab and longitudinally relative to the fiber positions on the opposite side to increase the pump reflection. The high N.A. of the fibers also acts to increase the uniformity of the pump illumination on the slab. Since the slab is only half an absorption depth thick, we have gold coated all the surfaces surrounding the slab to increase the pump absorption and to improve the overall efficiency. We have attempted to reduce any possible corrosion due to the use of dissimilar metal by hard anodizing the aluminum, gold electroplating the brass, and using deionized water. The assembly of this laser head is simple and typically takes less than 10 minutes.

Once the slab is coated, it is placed in the laser head, a schematic of which is shown in figure 1. The Nd:YAG slab is mounted in an aluminum frame and sealed at both ends. We place the O-rings on the slab just as one would place O-rings on a rod. No care taken to locate the O-rings away from a bounce point since the slab is protected by the low index coating. The top and bottom of the slab are insulated by placing gold-coated glass microscope slides in contact with the Nd:YAG slab. The glass slides are coated on the back with a thin RTV silicone layer to relieve stress. The last two sides of the frame contain the fiber pump modules. The Nd:YAG slab is water cooled with 2 mm thick water channels flowing between the slab surfaces and the brass fiber holders. The water flows at a rate of 1 liter per minute and the Reynolds number and flow geometry were selected to make the flow turbulent. The turbulent flow does not create phase distortions on the laser beam because the evanescent wave is isolated from the water flow by the protective Teflon AF[®] coating. The fibers are isolated from the water flow by a 0.5 mm anti-reflection (AR) coated sapphire window glued onto the brass mount. The inside surface of the brass

5. EXPERIMENTAL RESULTS



Figure 2. HeNe interferometer fringe pattern of slab pumped with 125 W of unextracted power.

To test the effectiveness of our cooling design, we built a HeNe interferometer around the slab laser head and counted fringes as the pump power was varied. Average heating of the slab does not add any curvature to the fringe pattern but does change the path length in one arm of the interferometer. The average temperature rise in the pumped slab can be determined by counting fringes. In a previous conduction cooled design the slab temperature rose beyond 150° C due to poor thermal contact across the interface layers. In the water cooled design, the average temperature of the slab rises less than 30° C, demonstrating the effectiveness of heat transfer from the slab into the water. The interferometer also allowed us to measure any thermal non-uniformity by observing the curvature of the fringe pattern. The fringes for the unpumped slab are flat to better than 1/10th wave and demonstrate that there is no net polishing error or mounting stress distorting the slab. When pumped, there is a minor cylindrical lens created by the non-ideal insulation. A picture of the interferometer fringe pattern with the slab pumped with 125 W is shown in figure 2. At this level, the fringe pattern shows a slight fringe curvature of less than 1/4 wave. Even at the full pump power, the fringe curvature is less than 1 wave of distortion. This curvature corresponds to a weak cylindrical lens of approximately 1 meter focal length which is easily compensated in the resonator design.

The laser was initially tested with a short confocal cavity. This cavity consisted of a 20 cm radius of curvature HR mirror placed 2 cm from one slab end and a flat 21% output coupler placed 11 cm from the opposite mirror. The diode laser input power was calculated by monitoring the current to all 25 diode lasers and converting to optical power using previous calibration measurements. At a pump power of 235 W emitted from the fibers, the zig-zag slab laser emitted 72 W in a square, multimode beam. The optical-to-optical slope efficiency was 36% with a threshold of 30 W. The gain was measured by probing the active volume with a Lightwave Electronics 300 mW laser. The small signal gain is $e^{0.9}$. At this level of gain, the laser should be analyzed with the Rigrod laser equation.²⁸ We have varied the output coupling from 15 to 30% with only small changes in output power, as expected.

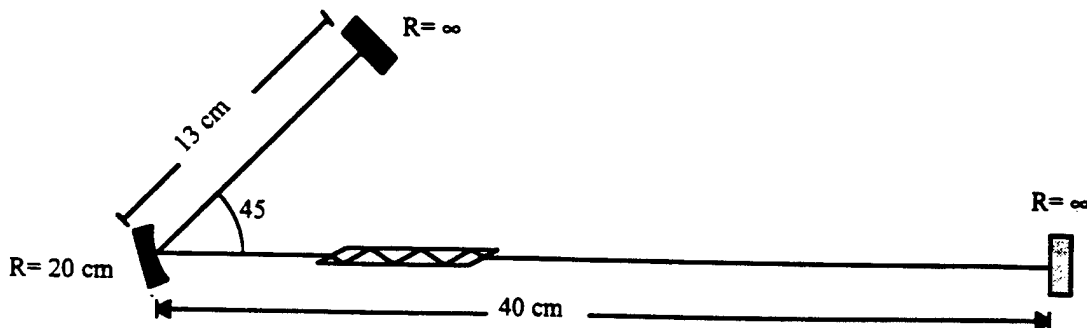

Figure 3. Cavity design for TEM₀₀ mode operation.

The laser was also operated in a TEM₀₀ mode configuration. The best performance was obtained by using a three mirror folded cavity as shown in figure 3. The asymmetric thermal lens is compensated by using the astigmatism from an

off-axis concave mirror. A 20 cm radius of curvature mirror was chosen to dominate the thermal lensing in the cavity and the fold angle necessary to obtain TEM₀₀ mode operation at full power was 45°. The mode size in the Nd:YAG slab is 500 μm and can be changed by small displacements in the short 13 cm leg. It is adjusted so that clipping around the Nd:YAG slab prevents higher order modes from oscillating. TEM₀₀ mode operation was confirmed by displaying the beat note from a fast photodetector on a spectrum analyzer as well as monitoring a portion of the output beam with a scanning slit. At most power levels, 55% of the multimode power could be obtained in a TEM₀₀ mode by appropriate cavity adjustment. We obtained 40 W in a TEM₀₀ mode at a pump power level of 212 W. The slope efficiency for TEM₀₀ mode operation was 22%. Figure 4 shows the Nd:YAG cw output power vs. diode laser input power for both multimode and TEM₀₀ mode operation. The M² value was measured using the knife edge technique and was found to be less than 1.3 in both directions. The output is polarized due to the Brewster slab faces with a polarization ratio better than 100:1.

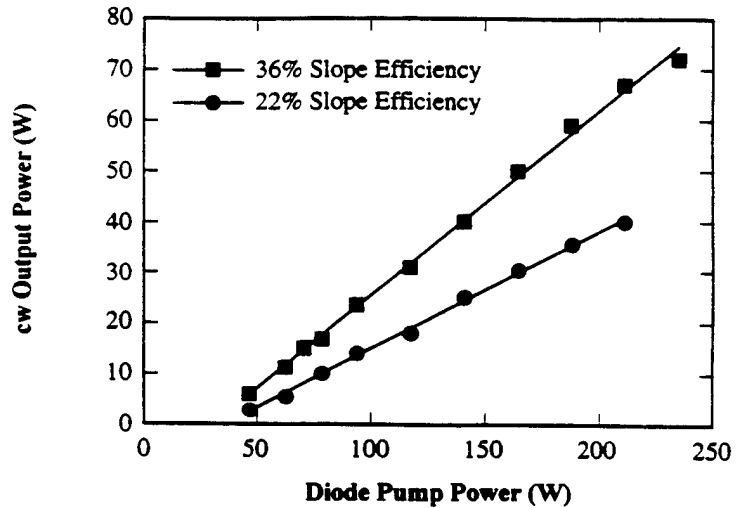

Figure 4. Input vs. output curves for multimode (squares) and TEM₀₀ mode (circles) operation.

Figure 4 shows the Nd:YAG cw output power vs. diode laser input power for both multimode and TEM₀₀ mode operation. The M² value was measured using the knife edge technique and was found to be less than 1.3 in both directions. The output is polarized due to the Brewster slab faces with a polarization ratio better than 100:1.

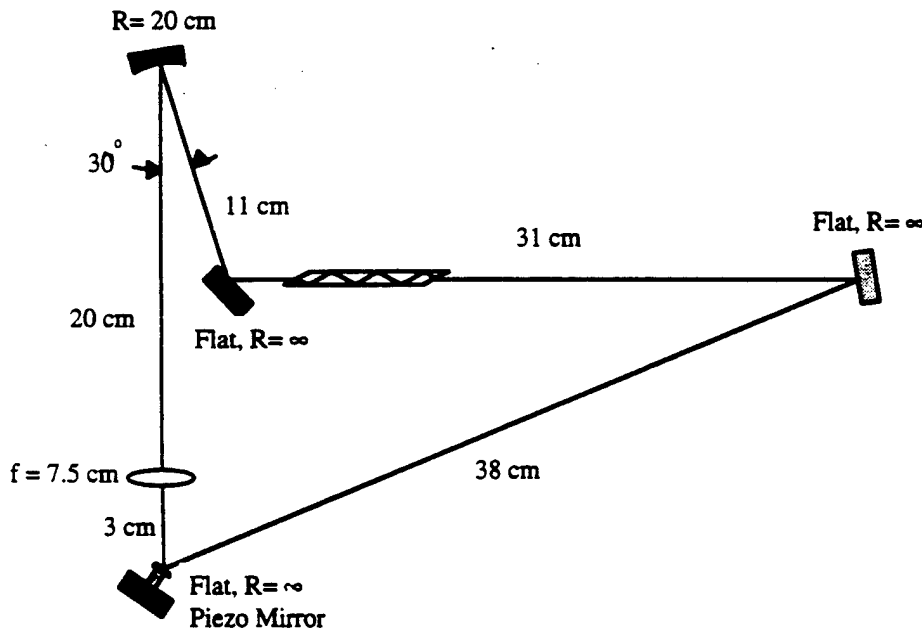

Figure 5. Ring laser cavity used for injection locking.

Finally, we injection locked the laser using the Pound-Drever-Hall FM sideband locking technique.^{29,30} In the linear cavity described by figure 3, a waist occurs at each of the flat end mirrors. We have closed the cavity into a ring by transforming one waist to the other using an intracavity lens. The cavity diagram is shown in figure 5. The top half of the cavity is identical to the linear cavity run previously. The flat mirror placed next to the slab is used to steer the cavity beam away from the diode-laser pump fibers. Since there is no astigmatism in the bottom half of the cavity, a 7.5 cm focal length spherical lens was used in place of an off-axis concave mirror and the ring was closed

using a flat mirror. This cavity runs in a TEM₀₀ mode but at lower power than the linear cavity due to additional clipping at the slab mount. We believe optimization of the intracavity lens focal length and position will improve the output power. We have operated at 165 W of pump power because the cavity has not yet been optimized at the full pump power. At this pump power level, we obtained a single frequency output of 20 watts.

We have injection-locked the laser using a Lightwave Electronics model #122-1064-300-F laser as the master oscillator with the slave laser cavity length stabilized using the FM sideband locking technique. The piezo-mounted mirror has a resonant frequency of 30 kHz, and only this one moderately fast piezo element was needed for stable locking. To compensate for slow temperature drifts in the cavity and to keep the piezo element away from the limits of its throw we have built a feedback circuit to control the master oscillator temperature. This circuit uses the pole in the Lightwave Electronics laser temperature response near 1 Hz and does not affect the much faster cavity servo lock used in the FM sideband technique. Single frequency output was confirmed by using a scanning confocal interferometer, as shown in figure 6. Using both feedback circuits we have observed stable locking over periods greater than an hour at 20 watts of output power. In the future we plan to use this laser as a source for nonlinear frequency conversion.

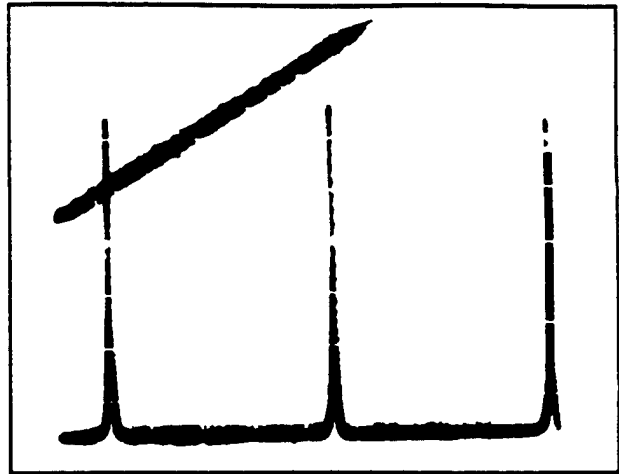

Figure 6. Confocal interferometer trace displaying single frequency output. Upper line displays ramp voltage to interferometer.

6. CONCLUSION

In summary, we have built and demonstrated a zig-zag slab laser that emits 72 W cw multimode when pumped with 235 W or 40 W TEM₀₀ when pumped with 212 W of diode laser power. Reasonable efficiency for the side-pumped slab design was obtained by confining the pump power within a gold-coated box containing the slab. This also created a uniform thermal loading profile in the slab laser and contributed to the good fringe pattern. The mounting and cooling problems of the slab laser design were overcome by developing a new coating technique to protect the slab TIR surfaces. This simplified the laser head design and allowed us to design a simple water-cooled structure with less than one wave of distortion at full pump powers of 235 W. The slightly non-ideal loading and cooling of the slab laser created a minor cylindrical thermal lens which is compensated by an off axis concave mirror. In addition, we have injection locked the laser to obtain a single frequency output of 20 watts at a pump power of 165 watts. Because of the thermal handling benefits of the slab laser design, this laser can be scaled to higher output powers with appropriate scaling of the laser gain medium.

7. ACKNOWLEDGMENTS

The authors wish to acknowledge useful discussions with Alex Farinas and Eric Gustafson. The research was funded by ARO grant #DAAH04-94-6-0019.

8. REFERENCES

1. A. Abramovici, W. E. Althouse, R. W. P. Drever, Y. Gürsel, S. Kawamura, F. F. Raab, D. Shoemaker, L. Sievers, R. E. Spero, K. S. Thorne, R. E. Vogt, R. Weiss, S. E. Whitcomb, M. E. Zucker, "LIGO: The Laser Interferometric Gravitational-Wave Observatory," *Science* 256, pp. 325-333 (1992).
2. S. C. Tidwell, J. F. Seamans, and M. S. Bowers, "Highly efficient 60-W TEM₀₀ cw diode-end-pumped Nd:YAG laser," *Opt. Lett.* 18, pp. 116-118 (1993).
3. D. Golla, S. Knoke, W. Schöne A. Tünnermann, and H. Schmidt, "High Power Continuous-Wave Diode-Laser-Pumped Nd:YAG Laser," *Appl. Phys. B* 58, pp. 389-392 (1994).
4. W. Koehner, *Solid State Laser Engineering*, 3rd ed. (Springer-Verlag, New York, 1992), Chap. 7, pp. 382-396.
5. J.M. Eggleston, T.J. Kane, K. Kuhn, J. Unternahrer and R.L. Byer, "The Slab Geometry Laser--Part 1: Theory," *IEEE J.Q.E* 20, pp. 289-301 (1984).
6. B. J. Comaskey, R. Beach, G. Albrecht, W. J. Bennett, B. L. Frietas, C. Petty, D. VanLue, D. Munding, and R. W. Solarz, "High Average Power Diode Pumped Slab Laser," *IEEE J. Q. E.* 28, pp. 992-996 (1992).

7. R. J. St. Pierre, H. Injeyan, R. C. Hilyard, M. E. Weber, J. G. Berg, M. G. Wickham, C. S. Hofer, and J. P. Machan, "One Joule Per Pulse, 100 Watt, Diode-Pumped, Near Diffraction Limited, Phase Conjugated, Nd:YAG Master Oscillator Power Amplifier," in Diode Pumping of Average-Power Solid State Lasers, Proc. SPIE 1865, pp. 2-8 (1993).
8. J. G. Endriz, M. Vakili, G. S. Browder, M. deVito, J. M. Haden, G. L. Harnagel, W. F. Plano, M. Sakamoto, D. F. Welch, S. Willing, D. P. Worland, and H. C. Yao, "High Power Diode Laser Arrays," IEEE J. Q. E. 28, pp. 952-965 (1992).
9. J. Berger, D. F. Welch, W. Streifer, D. R. Scifres, N. J. Hoffman, J. J. Smith, and D. Radecki, "Fiber-bundle coupled, diode end-pumped Nd:YAG laser," Opt. Lett. 13, pp. 306-308 (1988).
10. R. L. Byer, "Diode Laser-Pumped Solid-State Lasers," Science 239, pp. 742-747 (1988).
11. A. D. Farinas, E. K. Gustafson, and R. L. Byer, "Design and characterization of a 5.5-W, cw, injection-locked, fiber-coupled, laser-diode-pumped Nd:YAG miniature-slab laser," Opt. Lett. 19, pp. 114-116 (1994).
12. Product information, SDL Inc., 80 Rose Orchard Way, San Jose, CA 95134.
13. Koechner, *ibid*, p. 397.
14. A. J. Alfrey, "Simple 1 Micron Ring Laser Oscillators Pumped by Fiber-Coupled Laser Diodes," IEEE J. Q. E. 30, pp. 2350-2355 (1994).
15. V. Magni, "Resonators for solid-state lasers with large-volume fundamental mode and high alignment stability," Appl. Opt. 25, pp. 107-117 (1986).
16. W. C. Scott and M. de Wit, "Birefringence compensation and TEM₀₀ mode enhancement in a Nd:YAG laser," Appl. Phys. Lett. 18, pp. 3-4 (1971).
17. R. Weber, B. Neuenschwander, H. P. Weber, and P. Albers, "High power single-end diode-pumped Nd:YAG laser," in Digest of Conference on Lasers and Electro-Optics: Europe (Optical Society of America, Washington, DC, 1994) pp. 84-89.
18. W. Koechner, *ibid*, p. 390.
19. T. J. Kane, "Coherent Laser Radar at 1.06 Microns Using Solid State Laser," Ph.D Dissertation, Stanford University, 1986, pp. 91-105.
20. T. J. Kane, R. C. Eckardt, and R. L. Byer, "Reduced Thermal Focusing and Birefringence in Zig-Zag Slab Geometry Crystalline Lasers," IEEE J. Q. E. 19, pp. 1351-1354 (1983).
21. A.E. Siegman, *Lasers* (University Science, Mill Valley, Calif., 1986), Chap. 22, pp. 865-890.
22. A. E. Siegman, *ibid*, p.691.
23. W.F. Krupke, M.D. Shinn, J.E. Marion, J.A. Caird and S.E. Stokowski, "Spectroscopic, optical, and thermomechanical properties of neodymium- and chromium-doped gadolinium scandium gallium garnet," JOSA B 3, pp. 102-113 (1986).
24. K. S. Kim, H. J. Kong, and C. J. Kim, "Measurement of the temperature and the pumping uniformity inside a Nd:YAG rod by an interferometric method," Appl. Phys. Lett. 58, pp. 1810-1812 (1991).
25. L. E. Zapata, K. R. Manes, D. J. Christie, J. M. Davin, J. A. Blink, J. Penland, R. Demaret, and G. Dallum, "Performance of a 500 Watt Nd:GGG zig-zag slab oscillator," in Solid State Lasers, Proc. SPIE 1223, pp. 259-273 (1990).
26. R. J. Shine Jr., A. J. Alfrey, and R. L. Byer, "A cw, TEM₀₀ Mode, Diode-Laser-Pumped, Nd:YAG mini-Slab Laser," in Advanced Solid-State Lasers, Technical Digest, (Optical Society of America, Washington, DC, 1994) pp. 60-62.
27. Product information, E. I. duPont Nemours & Company (Inc.), Polymer Products Department, Wilmington, DE 19898.
28. W. W. Rigrod, "Saturation effects in high-gain lasers," J. Appl. Phys. 36, pp. 2487-2490 (1965).
29. R. W. P. Drever, J. L. Hall, F. V. Kowalski, J. Hough, G. M. Ford, A. J. Munley, and H. Ward, "Laser Phase and Frequency Stabilization Using an Optical Resonator," Appl. Phys. B 31, pp. 97-105 (1983).
30. C. D. Nabors, A. D. Farinas, T. Day, S. T. Yang, E. K. Gustafson, and R. L. Byer, "Injection locking of a 13-W cw Nd:YAG ring laser," Opt. Lett. 14, pp. 1189-1191 (1989).

Single Axial-Mode Oscillation of a Coupled Cavity Yb:YAG Laser

Takunori TAIRA and Takao KOBAYASHI

Faculty of Engineering, Fukui University, 3-9-1 Bunkyo, Fukui 910, JAPAN

*William M. TULLOCH and *Robert L. BYER

*Edward L. Ginzton Laboratory, Stanford University, Stanford, CA 94305, U.S.A.

Abstract

Single axial mode operation of a Yb:YAG laser was achieved with a 33.9mW threshold and 32% slope efficiency. An uncoated Yb:YAG crystal assisted with mode selection for the 913nm Ti:Al₂O₃ pumped microchip laser.

Laser resonators, Optical resonators, Laser materials, Rare earth solid-state lasers

Summary

Trivalent Yb ion doped solid-state materials are attractive as high efficiency, high stability, high energy laser. Diode-pumped Yb:YAG laser has several advantages relative to Nd:YAG lasers; i.e., low thermal load, long upperstate life time and large absorption width around the InGaAs laser emission range. In addition, Yb:YAG has no excited state absorption and upconversion loss¹. A great deal of effort has been made toward high efficiency and high power operation with diode-pumped Yb:YAG lasers^{2,3}. What seems to be lacking, however, is about a single-axial mode operation. Although a Yb:YAG laser has a relatively wide fluorescence bandwidth, ~2.66 THz, that is a disadvantage for single-axial mode oscillation. In this paper, we report our recent results for single axial-mode oscillation of Yb:YAG with using a coupled-cavity configuration.

Figure 1 shows the schematic of the coupled cavity Yb:YAG laser geometry. In this configuration, we must take account into three mirror effects⁴. For a three mirror cavity, the transmitted electric field from output mirror is given by

$$E_r = \frac{t_2 t_3 \sqrt{\tilde{g}_1 \tilde{g}_2}}{1 - r_2(r_1 \tilde{g}_1 - r_3 \tilde{g}_2) - r_1 r_3 \tilde{g}_1 \tilde{g}_2} E_s \quad (1)$$

where r_1, r_2, r_3 are the reflectivity for the electric field amplitude of the surface of 1, 2 and 3, respectively, $\tilde{g}_1 = \exp(\gamma_1 - j\phi_1)$, $\tilde{g}_2 = \exp(\gamma_2 - j\phi_2)$ are the round-trip gains which include the laser gain or loss, γ_1 and γ_2 , and the phases, ϕ_1 and ϕ_2 . We find a threshold condition from the denominator of Eq. (1). With the gain coefficient g_1 and the loss coefficient α_1 , it is possible to represent the laser gain or loss as $\gamma_1 = (g_1 - \alpha_1)L_1$, where L_1 is the length of region 1. From the three mirror model, a threshold gain coefficient are given by

$$g_{th} = \alpha_1 - \frac{1}{L_1} \ln \frac{r_1(r_3 e^{\gamma_2} \cos(\phi_1 + \phi_2) + r_2 \cos \phi_1)}{1 + r_2 r_3 e^{\gamma_2} \cos \phi_2} \quad (2)$$

From this model, a threshold of the resonant cavity and non-resonant cavity mode are given by

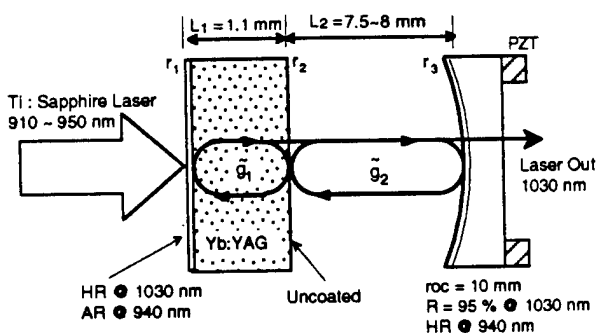

Fig. 1 Schematic of the coupled cavity Yb:YAG laser. The internal surface of Yb:YAG crystal is uncoated.

$\cos \phi_1 = \cos \phi_2 = \cos(\phi_1 + \phi_2) = 1$ and $\cos \phi_1 = \cos \phi_2 = -\cos(\phi_1 + \phi_2) = -1$, respectively. The threshold ratio of the resonant mode with three mirror cavity compare to a conventional two mirror cavity with a anti-reflection coated crystal is given by $R_2 = 0$. As R_2 of Eq. (2) increases, it is evident that the threshold ratio of the non-resonant mode to resonant mode ($g_{th,NR}/g_{th,R}$) becomes large so that the multi-longitudinal mode operation is suppressed. The internal face of the crystal for conventional laser cavity is AR-coated at laser wavelength to avoid the reflectivity loss. Following conventional concept a laser which has uncoated crystal has a higher threshold than the anti-reflection coated crystal and it is difficult to oscillate because it has the Fresnel loss for lasing wavelength. However, it is expected that single longitudinal mode oscillation using an uncoated crystal should have a low threshold. From Eq. (2), we obtain $(g_{th,NR}/g_{th,R}) = 3.31$ and $(g_{th,R}/g_{th,AR}) = 0.55$.

A Yb:YAG crystal with 10-at.-% Yb³⁺ doping (Scientific materials Co.), with dimensions a diameter of 4 mm and thickness of 1.1mm was used for this experiments. Typically longitudinally pumped configurations require an interface coated for high reflectivity (>99.9 %) at the lasing wavelength and high transmission (>80 %) at the pumping wavelength to couple the pump light into the laser cavity. The Yb:YAG crystal has high transmission from 920 nm to shorter wavelength, therefore these experiments were conducted using a Ti:Al₂O₃ pump laser tuned to 913 nm which is third absorption peak of the Yb:YAG crystal. An opposite side of the

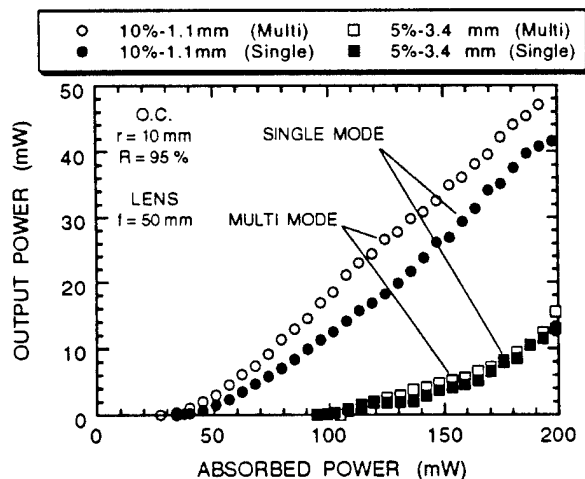

Fig. 2 Input-output power characteristics of the coupled cavity Yb:YAG laser pumped by a Ti:sapphire laser. Up to 42 mW power of single frequency output has been obtained without any intracavity elements.

Yb:YAG crystal has the Fresnel loss, ~8.45%. The external mirror was a 10 mm radius of curvature mirror, coated for a reflectivity of 95 % at 1030 nm and > 99 % at the pump wavelength. The position of this external mirror was separated 7.5~8.0 mm from the crystal and adjusted by a piezo-electric-device (PZT). A 50 mm focal length mode matching lens was used to focus the pump beam to a diameter of 58 μ m in the laser crystal. The temperature of the laser holder was controlled by using a thermo-electric cooler set at 20 °C. In our case, the free spectral range (FSR) of the Yb:YAG crystal and a total cavity length are ~75 GHz and ~17 GHz, respectively.

The Yb:YAG output power vs. Ti:Al₂O₃ absorbed pump power for the laser operating in a single axial mode is shown in Figure 2. The threshold was measured to be 27.1 ~ 33.9 mW and the slope efficiency was $\eta_s = 32$ % in single axial mode relative to the absorbed power at 913 nm. The maximum output power for the microchip laser was 41.6 mW for single axial mode oscillation at 198 mW of absorbed pump power. The maximum output power reached 50.4 mW for multi axial mode operation. On other hand, with an AR-coated crystal the threshold power was 41.8 mW and the maximum output power was 91.2 mW in multi axial mode operation. Therefore, the threshold power using uncoated crystal is 20 ~ 35 % lower than using AR-coated crystal, which is in good agreement with the theoretical results.

In conclusion, single-axial-mode oscillation of Yb:YAG laser has been demonstrated with a the wide FWHM fluorescence of 9.4 nm, or 2.66 THz at 1030 nm. An uncoated Yb:YAG crystal was used to operate as a coupled cavity laser configuration. This technique not only achieve the single axial mode operation but also decrease the threshold power. These effects are consistent with our theoretical and experimental results. Single axial mode Yb:YAG may find applications as stable master oscillator for higher power Yb:YAG lasers.

References

1. P. Lacovara, H. K. Choi, C. A. Wang, R. L. Aggarwal, and T. Y. Fan, *Opt. Lett.*, vol. 16, no. 14, pp.1089-1091, 1991.
2. D. Sumida and T. Y. Fan, *LEOS Annual Meeting, PaperSS3.2*, 1994.
3. U. Brauch, A. Giesen, M. Karszewski, C. Stewen, and A. Voss, *Opt. Lett.*, vol. 20, no. 7, pp. 713-715, 1995.
4. T. Taira, W. M. Tulloch, R. L. Byer, and T. Kobayashi, *Extended Abstracts (The 42 th Spring Meeting, 1995) the Japan Society of Applied Physics of Applied Physics, Tokyo, Japan, Paper 18pA12*.

CW Singly-resonant Optical Parametric Oscillators Based on 1.064- μm -pumped Periodically Poled LiNbO₃

Lawrence E. Myers

USAF Wright Laboratory, WL/AJL, Wright-Patterson AFB OH 45433

Walter R. Bosenberg, Jason I. Alexander

Lightwave Electronics Corp., Mountain View CA 98019

Mark A. Arbore, Martin M. Fejer, Robert L. Byer

Stanford University, Ginzton Laboratory, Stanford CA 94305

Abstract

We report cw singly resonant optical parametric oscillators with thresholds <3 W, output powers >2.5 W at $3.3 \mu\text{m}$, and tunable over 1.4 - $1.6 \mu\text{m}$ and 3.1 - $4.0 \mu\text{m}$.

Key Words

Nonlinear optics-parametric processes, Parametric oscillators and amplifiers, Nonlinear optical materials, Nonlinear optical devices.

The better stability of singly resonant optical parametric oscillators (SROs) compared with doubly resonant optical parametric oscillators (DROs) is well known.[1] Equally well known is the 100x higher threshold of a SRO vs. that of a DRO. In the cw regime, much work has gone into stabilizing DROs; however, even with complex control loops and careful cavity design, continuous tuning is limited to <10 GHz.[2] The first cw SRO was demonstrated in 1993 using a custom-built resonantly-doubled single-frequency Nd:YAG pump laser with KTP, but significant tuning was not possible.[3, 4] Despite the limited utility of this device, it demonstrated the important result of stable SRO behavior from a cw OPO.

In this paper, we present cw SROs based on the recently-developed nonlinear optical material periodically poled LiNbO₃ (PPLN). The high gain, low loss, and widely-tunable noncritical quasi-phaseshatching of PPLN have been shown to be useful for OPOs pumped by low peak power lasers, e.g. high-repetition-rate Q-switched solid-state lasers, long-pulse

Nd:YAG lasers, and commercial cw diode lasers.[5] These attributes have now enabled us to demonstrate practical cw SROs with stable, efficient, single-frequency output using simple cavities and commercially-available pump laser powers. Low threshold and adjustable quasi-phaseshatching of a PPLN SRO permit direct pumping with $1.064 \mu\text{m}$ for a useful source of coherent cw radiation tunable over the spectrally important mid-IR range from $1.3 \mu\text{m}$ to $\sim 5 \mu\text{m}$.[6]

The PPLN used in this work was fabricated with the same electric-field poling methods reported elsewhere.[5] Since the first QPM OPO was demonstrated with 5-mm-long PPLN in 1994, the length of available crystals has grown dramatically. The poling methods are now successfully applied to full 3"-diameter 0.5-mm-thick LiNbO₃ wafers. The crystals for this cw SRO were 50-mm long with $29.75 \mu\text{m}$ period, which quasi-phaseshatched at $1.57\text{-}\mu\text{m}$ signal and $3.45\text{-}\mu\text{m}$ idler with $1.064\text{-}\mu\text{m}$ pumping at 175°C .

The experimental set-up is shown in Fig. 1. The pump laser is diode-pumped Nd:YAG producing 17 W cw of polarized multi-longitudinal-mode output at $1.064 \mu\text{m}$. 13 W is available to pump the OPO. The pump beam is focused to a $97\text{-}\mu\text{m}$ waist radius in the crystal. The OPO resonator is a simple two-mirror symmetric linear cavity with round trip signal loss of $\sim 2\%$ and round-trip idler loss of $>99\%$.

Fig. 2 shows the OPO output vs. pump input. The threshold of 4.5 W agrees reasonably well with a calculated value of 3.7 W for a single-frequency pump laser,[7] indicating that all the laser modes pump a single mode of the resonant wave in an SRO.[1] The focusing parameter for this measurement is $\xi = L/b = 0.42$ where L is the crystal length and b is the confocal parameter of the pump (or signal) in the crystal. By

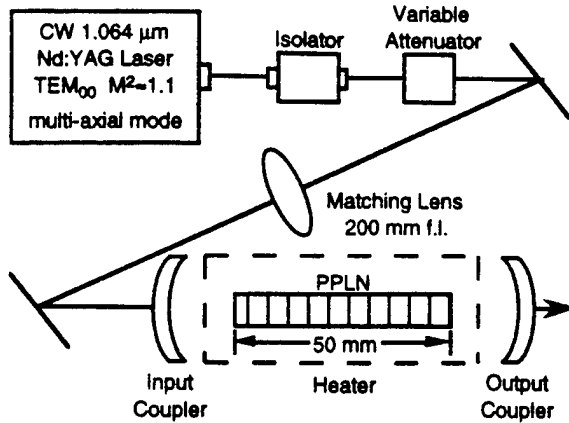

Figure 1. Experimental set up of cw SRO in PPLN. Mirrors have 50-mm radii of curvature and are separated by 104 mm. Reflectivities of the pump, signal, and idler are 2%, 99.7%, 3% for the input coupler, 14%, 99.5%, 11% for the output coupler, and 6%, 0.3%, 7% for each surface of the PPLN crystal.

focusing more tightly to give $\xi = 0.62, 1.0,$ and $1.6,$ we lowered the oscillation threshold to 4.2 W, 2.9 W, and 2.6 W respectively. However, tighter focusing caused a sudden increase in amplitude noise of the OPO output when the pump power was raised above 1.7x threshold. This sudden increase in noise was very repeatable. It is not yet clear if this behavior is intrinsic to a cw SRO with tight focusing or an experimental effect (e.g. thermal). With loose focusing, low-noise operation was obtained even pumping 3x above threshold.

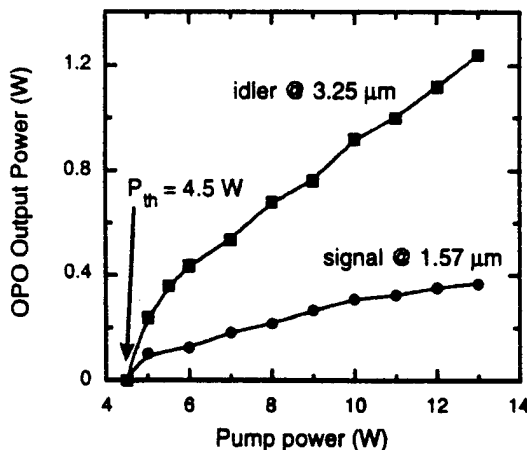

Figure 2. OPO output vs. pump input power for 29.75 μm period PPLN at 175 $^{\circ}\text{C}$. The maximum output is 1.25 W at 3.25 μm pumping with 13 W at 3x above threshold. Signal power is low because of the low output coupling used. With tighter focusing, thresholds <2.6 W were obtained.

The spectral qualities of the OPO signal output were observed using solid etalons. Despite a pump laser linewidth of ~ 2.2 GHz FWHM corresponding to ~ 9 longitudinal modes, the resonated signal wave operated on a single longitudinal mode with linewidth <0.02 cm^{-1} (0.5 GHz). As shown in Fig. 3, the free-running OPO stayed on one longitudinal mode for 10-20 sec until drift of cavity length or temperature caused a mode hop. When the cavity length was scanned, the OPO stayed on a single cavity mode over $>75\%$ of the free spectral range, indicating the singly-resonant nature. For a comparable DRO, mode hops occur for 2-nm cavity length change or 3-MHz pump frequency shift, over two orders of magnitude more stringent than the tolerances of the SRO.[8, 9]

While this device can be temperature tuned, operation <110 $^{\circ}\text{C}$ is limited by photorefractive damage as shown in Fig. 4. Tuning by changing the quasi-phasematching period provides wide tunability at fixed temperature. Using a 25-mm long PPLN crystal with multiple grating sections[6] we tuned the output from 1.62-1.46 μm (signal) and 3.11-3.95 μm (idler), limited by losses of the optical coatings. With the right optics, this cw SRO can tune across the entire mid-IR transparency range of LiNbO_3 1.3 μm to >4 μm .

We also operated the PPLN cw SRO using a four-mirror ring cavity in a bow-tie configuration. The threshold of this OPO was higher because of the additional optics, but it could be tightly focused without the increased noise seen in the linear cavity. The conversion efficiency was also much higher as shown in

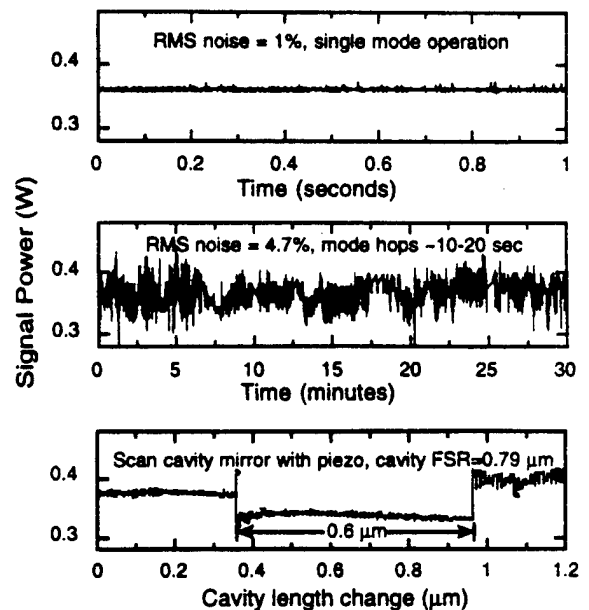

Figure 3. Stability of OPO signal power in PPLN cw SRO, with 6.7 W pump (2x threshold).

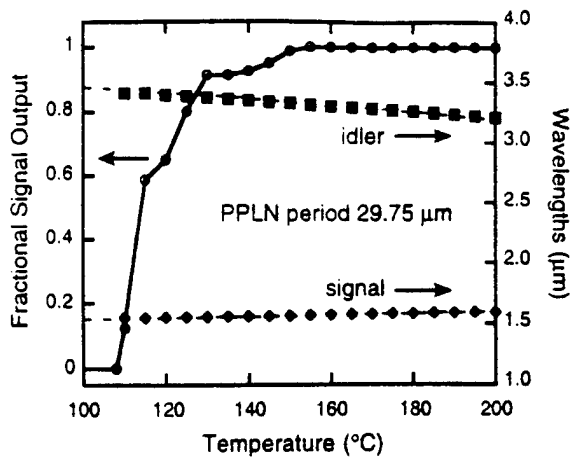

Figure 4. Heating the crystal eliminates photorefractive damage during OPO operation. Temperature tuning is possible as shown, but adjusting the quasi-phasematching period with a multi-grating PPLN chip gave broader tuning over 1.62-1.46 μm (signal) and 3.11-3.95 μm (idler) at 175 $^{\circ}\text{C}$ for PPLN periods 30-28 μm .

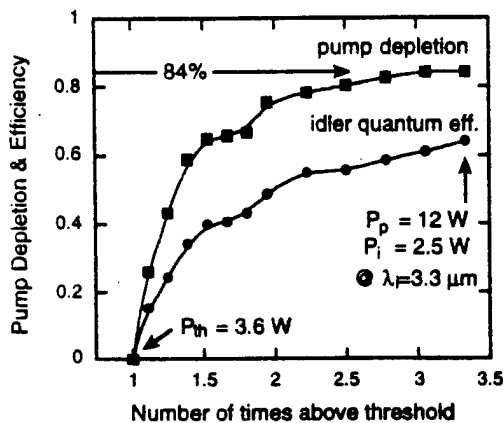

Figure 5. Pump depletion and idler quantum efficiency in the 4-mirror ring-cavity cw SRO. Pump depletion was 84% at 3x above threshold. Extracting this converted pump as idler was 76% efficient due to losses in the optical coatings. Idler power was 2.5 W with 12 W of pump for optical power conversion efficiency of 21%.

Fig. 5. Using the multi-grating piece described above, we obtained >1 W idler power over the tuning range 3-3.8 μm , and 0.6 W at 4 μm . The above-threshold behavior of cw SROs will be investigated in future experiments and theoretical modeling.

In conclusion, we have demonstrated practical implementations of cw SROs using PPLN. With simple OPO resonator designs, the threshold as low as 2.6 W is compatible with pumping with commercially

available multi-longitudinal-mode cw-diode-pumped 1- μm lasers. The stability ($\sim 1\%$ rms), high conversion ($>84\%$), high power (2.5 W at 3.3 μm), and single-frequency output ($<0.02\text{ cm}^{-1}$ linewidth) make these devices promising sources of coherent radiation tunable across the important mid-IR region.

Acknowledgments

We acknowledge Willam M. Tulloch for assistance with preliminary cw laser pumping experiments.

References

1. S. E. Harris, "Tunable optical parametric oscillators," *Proc. IEEE* **57**, 2096-2113 (1969).
2. F. G. Colville, M. J. Padgett, and M. H. Dunn, "Continuous-wave, dual-cavity, doubly resonant, optical parametric oscillator," *Appl. Phys. Lett.* **64**, 1490-2 (1994).
3. S. T. Yang, R. C. Eckardt, and R. L. Byer, "Continuous-wave singly resonant optical parametric oscillator pumped by a single-frequency resonantly doubled Nd:YAG laser," *Opt. Lett.* **18**, 971-973 (1993).
4. S. T. Yang, R. C. Eckardt, and R. L. Byer, "1.9-W cw ring-cavity KTP singly resonant optical parametric oscillator," *Opt. Lett.* **19**, 475-477 (1994).
5. L. E. Myers, R. C. Eckardt, M. M. Fejer, R. L. Byer, W. R. Bosenberg, and J. W. Pierce, "Quasi-phasematched optical parametric oscillators in bulk periodically poled LiNbO₃," *J. Opt. Soc. Am. B* **12**, 2102-2116 (1995).
6. L. E. Myers, R. C. Eckardt, M. M. Fejer, R. L. Byer, and W. R. Bosenberg, "Multi-grating quasi-phasematched optical parametric oscillator in periodically poled LiNbO₃," accepted for publication in *Opt. Lett.* (Jan. 1996).
7. S. Guha, F.-J. Wu, and J. Falk, "The effects of focusing on parametric oscillation," *IEEE J. Quantum Electron.* **18**, 907-912 (1982).
8. R. C. Eckardt, C. D. Nabors, W. J. Kozlovsky, and R. L. Byer, "Optical parametric oscillator frequency tuning and control," *J. Opt. Soc. Am. B* **8**, 646-667 (1991).
9. A. J. Henderson, M. J. Padgett, F. G. Colville, J. Zhang, and M. H. Dunn, "Doubly-resonant optical parametric oscillators: tuning behaviour and stability requirements," *Opt. Commun.* **119**, 256-264 (1995).

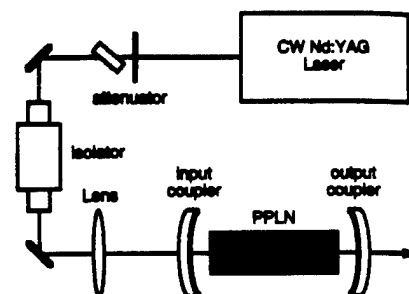

CThA3 Fig. 1 Schematic of the simple experimental configuration. The diode-pumped Nd:YAG laser produces 17 W of output. The periodically-poled lithium niobate (PPLN) is 50-mm long, and has a grating period of 29.75 μm for first order quasi-phase-matching.

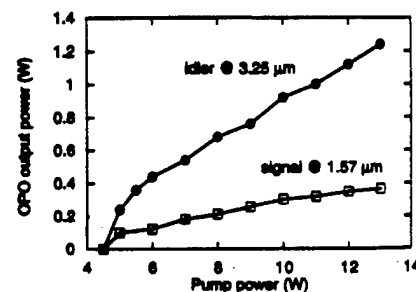

CThA3 Fig. 2 Output vs. input of the cw PPLN OPO. The oscillation threshold is 4.5 W, and the maximum output is 1.25 W at 3.3 μm , and 0.36 W at 1.57 μm with 13 W of pump.

CThA3

8:30 am

cw singly-resonant optical parametric oscillator based on periodically poled LiNbO₃

W. R. Bosenberg, A. Drobshoff, Jason I. Alexander, L. E. Myers,* W. Tulloch,* R. L. Byer,* Lightwave Electronics Corporation, 1161 San Antonio Rd., Mountain View, California 94043

The improved stability of singly resonant optical parametric oscillators (SROPOs, SROs) over doubly resonant optical parametric oscillators (DROPOs) is well known; however, due to the SRO's high oscillation threshold, its operation has been nearly exclusively restricted to pulsed devices. The first cw SRO was pumped by a resonantly doubled Nd:YAG laser. The OPO was operated near degeneracy, producing outputs with limited tunability at wavelengths near the fundamental of the pump laser (1 μm).¹ Our work is the first report of a broadly tunable cw SRO. We use the 1.064- μm radiation from a Nd:YAG laser to pump periodically poled lithium niobate (PPLN)² obtaining tunable radiation in the important 1.5- μm and 3.3- μm regions. The high gain and low loss of PPLN are the key to the operation of this device. The PPLN OPO operated robustly 2-3 times above threshold with a maximum pump depletion of 50%.

The experimental configuration is shown in Fig. 1. The pump laser is a single-transverse mode, multilongitudinal-mode diode-pumped Nd:YAG laser. The laser has an output of ~17 W with $M^2 = 1.1$. The pump beam is mode-matched to

the OPO cavity with a 97- μm beam waist (radius). A 50-mm-long PPLN crystal has a period of 29.75 μm for first order quasi-phase-matching and is anti-reflection coated resulting in reflectivities of 6%, 0.3%, and 7% for each surface, at the pump, signal, and idler wavelengths. The OPO cavity had a round-trip cavity loss of ~2% at the signal wavelength (0.5% at the output coupler, 0.3% at the input coupler), and 99.0% at the idler wavelength, satisfying the condition for singly resonant operation.³

Figure 2 shows the OPO output vs. input. The threshold of 4.5 W is in agreement with calculations. By focusing the pump more tightly, thresholds as low as 2.6 W were observed, but tighter focusing produced noise in the OPO output when pumped more than 1.7 times threshold. The resonated signal wave tended to operate on a single longitudinal mode of the OPO resonator despite a pump laser bandwidth of ~6 GHz. The free running OPO stayed on one longitudinal mode for 10-20 seconds until cavity length and/or crystal temperature drift caused the OPO to hop to a nearby longitudinal mode. No attempt was made to keep the OPO on one longitudinal mode.

To verify the improved amplitude stability of the SRO, we measured the signal output with a fast photodiode. During a 1 sec interval (Fig. 3a), the OPO ran on a single longitudinal mode, with 1% noise (rms). Over a 30 minute interval (Fig. 3b),

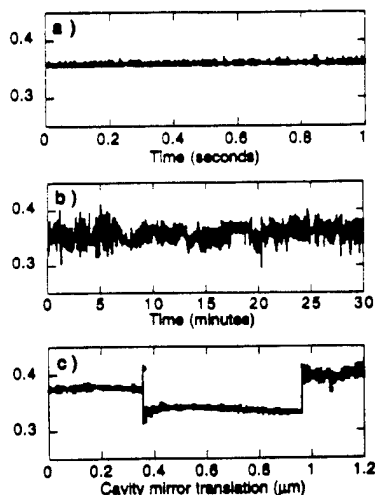

CThA3 Fig. 3 Noise characteristics of the cw SRO. The Y-axis of all three graphs is signal power in watts. Note that the bottom of the graph is not zero, therefore the fluctuations appear enlarged. a) Shows the output of the free-running OPO over a 1 sec interval with single-longitudinal-mode operation. b) Shows the output of the free running OPO over a 30 min interval with longitudinal mode hopping. The increased noise in b) is due to longitudinal mode-hopping in the OPO. c) Shows the OPO output when the cavity length is swept with a piezo-electric crystal. The well defined mode-hops that occur at a large fraction of the free spectral range of the signal cavity indicate the singly resonant nature of the device.

with the OPO mode hopping, the noise increased to 4.7% (rms). Figure 3c shows the OPO output when the cavity length is scanned with a piezo-electric crystal. The SRO nature of our device is revealed by observing mode hops only at cavity length changes that are a large fraction of the free spectral range of the OPO cavity.

We also operated the OPO with 25-mm-long PPLN crystals having multiple grating structures similar to those described in Ref. 4. We produced cw radiation over 3.1–4.0 μm (idler) and 1.45–1.62 μm (signal) by translating the crystal through the resonator into different grating sections. This tuning range was limited by the reflectivity range of the OPO cavity mirrors.

In summary, we have demonstrated a broadly tunable mid-infrared cw SRO that had a ~few watt threshold, produced >1 W of radiation, and was tuned through a technologically important spectral region.

This work was supported by an Air Force Phase I SBIR contract from Eglin Air Force Base, FL.

*E. L. Ginzton Laboratory, Stanford University, Stanford, California 94305

1. S. T. Yang, R. C. Eckardt, R. L. Byer, *Opt. Lett.* **19**, 475 (1994).
2. L. E. Myers, R. C. Eckardt, M. M. Fejer, R. L. Byer, W. R. Bosenberg, J.

- W. Pierce, *J. Opt. Soc. Am. B* **12**, 2102 (1995), and references therein.
3. S. T. Yang, R. C. Eckardt, R. L. Byer, *J. Opt. Soc. Am. B* **10**, 1684 (1993).
 4. L. E. Myers, R. C. Eckardt, M. M. Fejer, R. L. Byer, W. R. Bosenberg "Multigrating, quasi-phase-matched optical parametric oscillator in periodically poled LiNbO_3 ," submitted to *Opt. Lett.*