



# CHAIRMAN OF THE JOINT CHIEFS OF STAFF INSTRUCTION

J-8  
DISTRIBUTION: A, B, C, J, S

CJCSI 3170.01  
13 June 1997

## REQUIREMENTS GENERATION SYSTEM (FORMERLY MOP 77)

References: See Enclosure D

1. Purpose. To:

- a. Establish policies and procedures for the requirements generation system called for by DOD Directive (DODD) 5000.1 (reference a).
- b. Provide policies and procedures for developing, reviewing, validating, and approving Mission Need Statements (MNSs) and Operational Requirements Documents (ORDs) required by DODD 5000.1 and DOD Regulation 5000.2-R (reference b).
- c. Delegate oversight responsibility for the requirements generation system to the Vice Chairman of the Joint Chiefs of Staff, assisted by the Joint Requirements Oversight Council (JROC) and members of the Joint Staff.
- d. Provide guidelines for the conduct of program and milestone reviews for Major Defense Acquisition Programs (MDAPs) prior to the programs being forwarded for Defense Acquisition Board (DAB) review, and for Major Automated Information System (MAIS) acquisition programs prior to being forwarded to the Major Automated Information System Review Council (MAISRC).
- e. Provide policies and procedures for developing, reviewing, validating, and approving Capstone Requirements Documents (CRDs).
- f. Define the role of the JROC Secretary as the Joint Staff point of contact for the submission, handling, and review of MNSs, CRDs, and ORDs.

THIS QUALITY INSPECTED 8

DISTRIBUTION STATEMENT A

Approved for public release;  
Distribution Unlimited

19971121 185

2. Cancellation. CJCS Memorandum of Policy Number 77, 17 September 1992, "Requirements Generation System Policies and Procedures" is canceled.
3. Applicability. This instruction applies to the requirements generation system of the Joint Staff, Services, unified commands, and those DOD field activities and Defense agencies supporting the defense acquisition responsibilities of the Chairman of the Joint Chiefs of Staff. This instruction also applies, in general, to other agencies preparing and submitting requirements in accordance with DODD 5000.1 and DOD Regulation 5000.2-R (references a and b). Highly sensitive, classified programs will comply with this instruction, but will be tailored, as necessary, to account for special security considerations (reference a, page 2, and reference b, part I, page 3, paragraph 1.4). This instruction does not preclude the need to refer to the basic DOD 5000 series documents for guidance and direction on defense acquisition.
4. Policy
  - a. Authority. The Chairman of the Joint Chiefs of Staff assesses military requirements for defense acquisition programs and represents the CINCs with respect to their operational requirements (reference c, sections 153 and 163, respectively). The JROC facilitates the execution of these responsibilities (see reference c, section 181, and reference d for mission and organization, roles, and responsibilities).
  - b. Services' Role. The Services are responsible for organizing, supplying, equipping (including research and development), training, administering, and related functions in order to meet the current and future operational requirements of the unified commands. They are also charged with eliminating duplication through effective cooperation and coordination with the other Services and DOD agencies (reference c, sections 3013, 5013, and 8013).
  - c. CJCS Role. The Chairman of the Joint Chiefs of Staff, assisted by the Vice Chairman and other members of the Joint Chiefs of Staff, establishes and publishes policies and procedures governing the requirements generation system.
  - d. VCJCS Role. The Vice Chairman of the Joint Chiefs of Staff, assisted by the JROC, will oversee the operation of the requirements generation system in accordance with DOD 5000 series documents, and policies and procedures contained in this instruction, to ensure

13 June 1997

the responsibilities of the Chairman under title 10, United States Code, are fulfilled.

e. Implementation and Supplementation. This instruction will not be supplemented without the prior approval of the Vice Chairman of the Joint Chiefs of Staff or his delegated representative.

5. Definitions. Definitions are provided in the Glossary.
6. Responsibilities. Responsibilities are provided in Enclosure A.
7. Summary of Changes. The original Memorandum of Policy 77 has been changed into a CJCS instruction. This instruction reflects changes to the DOD 5000 series and title 10. It includes the addition of the Capstone Requirements document and clarification of the staffing process.
8. Effective Date. This instruction is effective upon receipt.

For the Chairman of the Joint Chiefs of Staff:



**DENNIS C. BLAIR**  
Vice Admiral, U.S. Navy  
Director, Joint Staff

Enclosures:

- A--Requirements Generation Process
- B--Mission Need Statement Format
- C--Capstone Requirements Document Format
- D--References
- Glossary

(INTENTIONALLY BLANK)

DISTRIBUTION

Distribution A, B, C, and J plus the following:

	<u>Copies</u>
Secretary of Defense .....	20
Commander, US Element, NORAD.....	10

(INTENTIONALLY BLANK)

ENCLOSURE A

REQUIREMENTS GENERATION SYSTEM

1. Requirements Generation Process. The requirements generation system, along with the acquisition management system and the Planning, Programming, and Budgeting System, form DOD's three principal decision support systems (see Figure 1). A close and effective interface among these systems is required to ensure quality products are acquired for the Nation's Armed Forces. The requirements generation

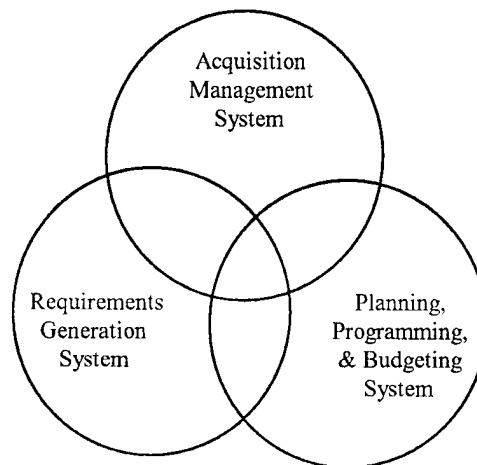

Figure 1. The Three Decision Support Systems

system produces information for decision makers on the projected mission needs of the warfighter. To accomplish this, the requirements generation process will be uniform throughout the Department of Defense. Specifically, the generation of requirements will consist of the following four distinct phases: definition, documentation, validation, and approval. As a system evolves from an MNS, to a CRD (if applicable), through ORDs, there are some differences in what is accomplished in each phase. The following appendixes describe the specific requirements for each phase for the MNS, CRD, and ORD. Figure 2 shows the phases as they apply to MNSs.

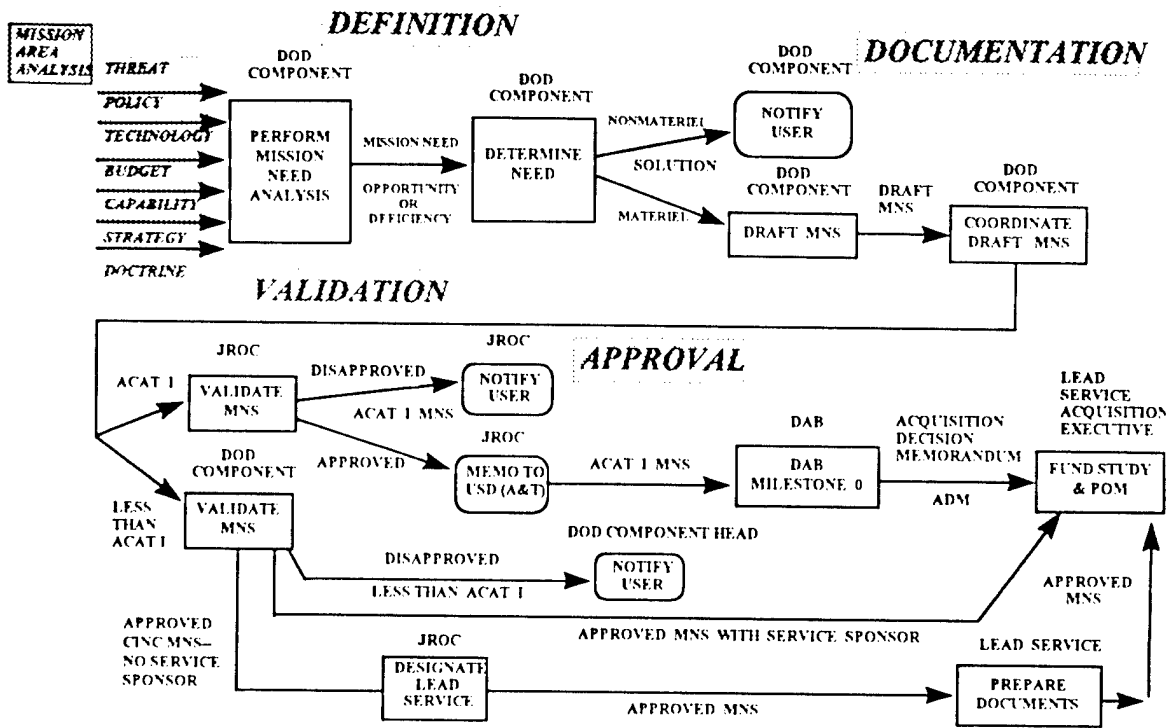

Figure 2. MNS Generation Process

a. Definition Phase. The activity that defines, describes, and justifies a mission need to satisfy a capability deficiency or exploit a technological opportunity is the definition phase. Mission needs will be identified as a direct result of continuing assessments (Mission Area Analysis or equivalent Service or DOD component procedure) of current and projected capabilities in the context of changing military threats and national defense policy. Mission needs will be assessed to determine if they can be satisfied through nonmateriel solutions such as changes in doctrine, operational concepts, tactics, training, or organization. If this is not feasible, then a new acquisition program(s) may be considered. DOD components will document new needs, major modifications, or significant technological leaps in an MNS. Once an acquisition program is approved, the operational requirements for the concept(s) selected will progressively evolve from broad operational capability needs found in the MNS to system-specific performance requirements found in the ORD (see Figure 3).

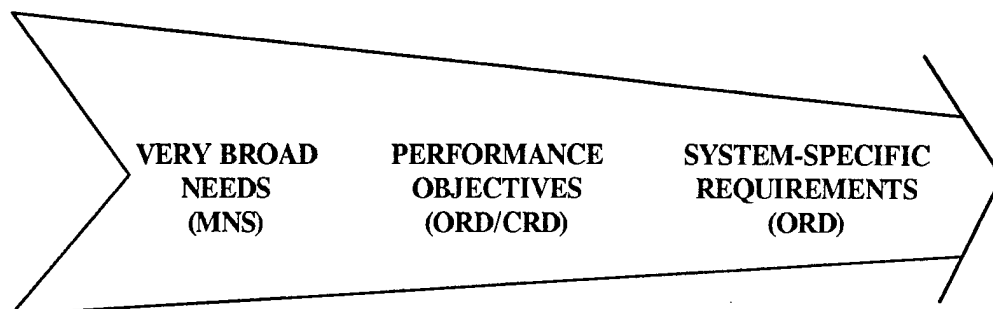

Figure 3. Requirements Evolution

b. Documentation Phase. The formal preparation and initial review of required and standardized documents in support of a defined mission need is the documentation phase. The primary requirements documents are the MNS, CRD (if applicable), and ORD. The MNS is a non-system-specific statement of operational capability need written in broad operational terms. Any DOD component may write and process an MNS. The CRD documents the overarching system requirements for a broad mission need (surveillance, missile defense, etc.). The ORD translates the MNS and CRD (if applicable) requirements into more detailed and refined performance capabilities and characteristics of a proposed concept or system. The MNS format is found in Enclosure B and the CRD format is found in Enclosure C of this instruction. The ORD format is found in Appendix II to DOD 5000.2-R (reference b).

c. Validation Phase. The validation phase is the formal review process of the requirements documents, by an operational authority other than the user, to confirm the identified need and operational requirement. The validation authority for MNSs, CRDs, and ORDs is dependent on ACAT level and/or if a program is of special interest.

d. Approval. Approval is a formal sanction that the validation process is complete and the identified need or operational capabilities described in the documentation are valid. Approval also warrants concept definition studies for a possible new acquisition program and certifies that the requirements documentation has been subject to the uniform process of the DOD 5000 series and this instruction. Approval authority is dependent on ACAT level, whether the JROC has special interest, or if approval authority has been delegated.

2. Responsibilities

a. JROC. Title 10, section 181, the DOD 5000 series, and the JROC charter specifically delineate the JROC's responsibilities. The JROC reviews potential ACAT I programs/MDAPs to support the DAB process and appropriate ACAT IA/MAIS acquisition programs to support the MAISRC process. The JROC may also address nonmajor defense acquisition programs to resolve contentious and high-interest issues, such as designation of lead Service or agency, resolution of requirements disconnects, or to review programs at the request of the Secretary of Defense, the Under Secretary of Defense for Acquisition and Technology (USD(A&T)), or the Assistant Secretary of Defense for Command, Control, Communications, and Intelligence (ASD(C3I)). The JROC will evaluate performance, cost, cost as an independent variable (CAIV) objectives, and schedule when considering acquisition programs.

b. Services. The Services will define mission needs and operational requirements, and will develop and coordinate the documentation with the Services and CINCs. Potential ACAT I MNSs are forwarded to the JROC Secretariat for coordination. The Service functions as validation and approval authority for Service-generated ACAT II and III MNSs and ORDs. The Chiefs are not viewed as users when validating an MNS written by one of their commands. An MNS validated by a CINC and forwarded for action to a Service does not need to be revalidated by the Service. The Services may also approve ACAT I program ORDs if granted ORD approval authority by the JROC.

c. CINCs and Component Commands. The CINCs and the Commander, US Element, NORAD, may validate and approve their own headquarters-generated MNSs that would result in potential ACAT II or III programs. The preferred method, however, is for the CINCs to identify their mission needs to the responsible Service component commander (in rare cases, another DOD agency). The component commanders will then coordinate the definition and documentation activities through their sponsoring Services' requirements system and keep the CINCs apprised of the status of the MNS. With the exception of USSOCOM, the CINCs have no acquisition executive and may not send an MNS directly to a component acquisition executive. Close coordination with the sponsoring Service (or DOD agency) is required.

(1) CINC Validation and Approval. The CINCs may validate their own potential ACAT II and III MNSs and are not viewed as the user

13 June 1997

for the purposes of validation. The CINCs should seek Service (or DOD agency) support as early as possible.

(2) Joint Staff Assistance. Joint Staff assistance may be needed in cases where there is no clear Service responsibility for the MNS. The intent is not to have the Joint Staff write the MNS, but to see that responsible DOD agencies are identified and a lead component is designated for validation and approval as soon as possible. The JROC will assign a Service or DOD agency if required. Functional areas on the Joint Staff will also provide assistance, as appropriate, with the development and coordination of CINC issues, when necessary.

(3) USSOCOM. Congress has designated USCINCSOC as a head of agency with a unique major force appropriation category (see reference c, section 167). Therefore, USCINCSOC can establish, validate, and approve USSOCOM requirements and budget for ACAT II and III programs.

d. Defense Agencies. Defense agencies may be tasked to manage acquisition programs. The agencies may develop their own MNSs as a DOD component or be asked to manage programs initiated by the CINCs or Services.

e. Joint Staff and DIA. The Joint Staff and DIA provide an important review and coordination function in support of the MNS, CRD, and ORD validation process. Joint potential; interoperability for command, control, communications, computers, and intelligence (C4I) systems; intelligence support; and munitions interoperability and insensitivity are of particular concern.

(1) Director, J-6, Joint Staff. J-6 will certify MNSs, CRDs, and ORDs for conformance with joint C4/C4I policy and doctrine, architectural integrity, and interoperability standards for all DOD C4I acquisitions, regardless of acquisition category. J-6 will coordinate C4 issues concerning MNSs, CRDs, and ORDs with concerned agencies (see references e and f). J-6 and DIA are responsible for reviewing and assessing C4ISR requirements and C4I Support Plans as described in reference b, part 2.2.1, "Evolution of C4ISR Support." A sample C4I Support Plan is contained in the OSD Defense Acquisition Deskbook. The J-6 will forward C4 interoperability certification to the JROC for ACAT I and appropriate ACAT IA programs, or to the sponsoring DOD component for ACAT II and III. Unresolved interoperability issues

will be forwarded by J-6 to the Military Communications-Electronics Board (MCEB) for resolution. The MCEB will ensure that unresolved issues resulting from interoperability assessments are presented to the JROC for resolution.

(2) DIA. DIA will provide threat validation on intelligence information used in potential ACAT I MNSs and ORDs. DOD components may validate their own ACAT II and III programs using DIA-validated threat data. DIA will also evaluate open systems architecture, interoperability, and compatibility standards for intelligence handling and intelligence-related information systems for all categories of MNSs, CRDs, and ORDs. DIA will certify all MNSs, CRDs, ORDs, and review C4I Support Plans for intelligence supportability and impact on joint intelligence strategy, policy, and architecture planning. DIA will forward intelligence certification to the JROC for ACAT I and appropriate ACAT IA programs, or to the sponsoring DOD component or agency for ACAT II and III. Unresolved intelligence issues will be forwarded by DIA to the Military Intelligence Board (MIB) for resolution. The Director, DIA, will ensure that unresolved issues resulting from intelligence assessments are presented to the JROC for resolution at each milestone review.

(3) Director, J-4, Joint Staff. J-4 will certify all potential ACAT I MNSs, CRDs, and ORDs for aviation munitions for cross-Service interoperability. Additionally, J-4 will certify that all MNSs, CRDs, and ORDs for munitions, regardless of ACAT level, conform with insensitive munitions design requirements to withstand unplanned stimuli through use of the least sensitive system design. Insensitive munitions and cross-Service interoperability waiver requests require approval by the JROC. Waiver requests will be submitted to J-4 for review and forwarding to the JROC Secretariat.

f. Staffing Process

(1) Standardized Documents. Requirements documents (MNSs, CRDs, and ORDs) that go before the JROC will be uniform across all DOD organizations and apply to all acquisition categories. This standardization instills discipline in the process and provides both the validation and approval authorities, and the acquisition management system, with efficient and consistent information to use in reviews and decision deliberations. The MNS format is found in Enclosure B, the CRD format is found in Enclosure C,

and the ORD format is found in Appendix II to reference b. Unique organizational formats are not authorized.

(2) Document Submission. All MNSs, CRDs, and ORDs that will go before the JROC must be submitted to the JROC Secretariat through the identified Service or DOD component JROC point of contact (POC). The document should be forwarded with a cover letter identifying the document, any schedule drivers, and a working-level POC. The documents should be sent to the J-8 Operational Requirements Branch (J-8/ORB) to enter into the formal review process. The submission should include one hard copy and an electronic copy in Microsoft Word format. All documents going through the review process are considered draft and do not require a formal signature until after JROC validation and/or approval.

(3) Document Review. Once a document enters the formal review process, it will be sent to all Services, CINCs, and appropriate DOD agencies for review as outlined in subparagraphs 3e, 4d, and 5e. Each comment should be identified as either:

CRITICAL. A critical comment will cause nonconcurrency in the document if the comment is not satisfactorily resolved.

SUBSTANTIVE. A substantive comment is provided because a section in the document appears to be, or is potentially, unnecessary, incorrect, misleading, confusing, or inconsistent with other sections.

ADMINISTRATIVE. An administrative comment corrects what appears to be a typographical, format, or grammatical error.

If there are any critical comments at the flag officer-level review, the Service or DOD component should nonconcur in the document until the issues have been resolved.

(4) Briefings. Once the review process has been completed, briefings for the pre-JROC, JROC Review Board, and JROC will be prepared in accordance with the JROC Administrative Guide (reference g).

3. MNS Generation Process

a. MNS Definition Phase. Identification of deficiencies and opportunities is a continuing process that normally begins with a review of the latest national security policy, National Military Strategy, Defense Planning Guidance (DPG), Joint Intelligence Guidance (if appropriate), and projected threats (see Figure 4). This information should be incorporated into an assessment of the current and projected capability to accomplish assigned missions. This evaluation is best accomplished by a Mission Area Analysis (MAA). The MAA, or equivalent Service or DOD component procedure, should identify

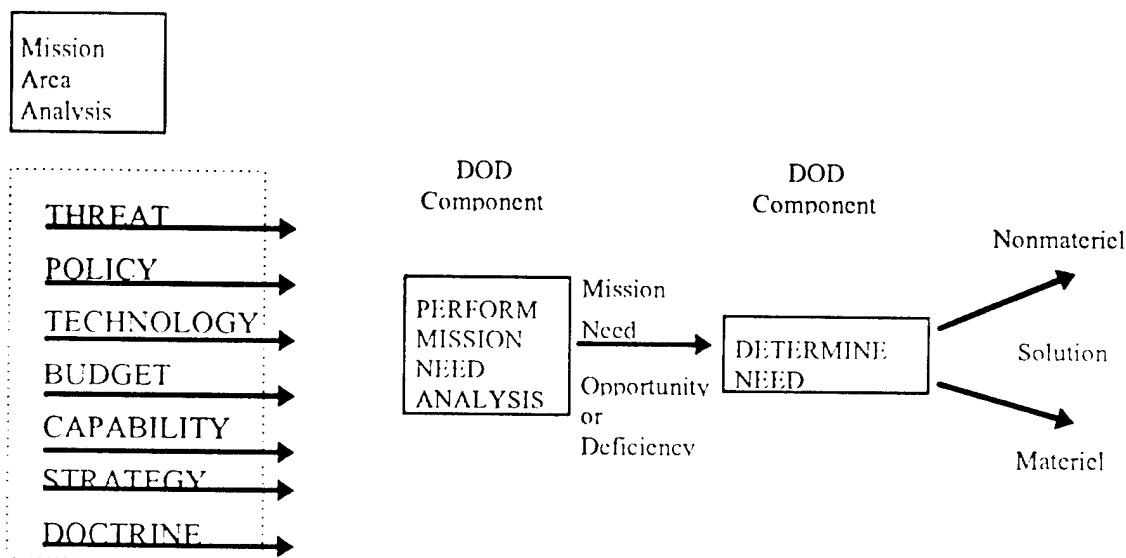

Figure 4. MNS Definition Phase

capability deficiencies. This analysis must look across Service or DOD component boundaries for solutions. The process may also begin with the identification of opportunities to exploit technology breakthroughs that provide new capabilities, reduce ownership costs, or improve the effectiveness of current equipment and systems. Identified deficiencies or opportunities are called mission needs. This analysis should also determine if the need can be satisfied by a nonmateriel solution. Nonmateriel solutions include changes in operational doctrine, concepts, tactics, training, or organization. If the need can be fulfilled by a nonmateriel solution, the sponsor should refer it to the appropriate DOD component for action. If the MAA determines that a materiel solution should be pursued, the deficiencies or technological opportunities should be translated into an MNS expressed in broad operational terms.

b. MNS Documentation Phase. When a Service or DOD component has determined that a materiel solution should be pursued, an MNS must be prepared in accordance with Enclosure B of this instruction and coordinated with the applicable Services, CINCs, and agencies, as well as any necessary higher headquarters, before forwarding to the validation authority for formal coordination (see Figure 5). If an existing validated MNS adequately covers a mission need, a new MNS may not be required. The MNS originator identifies whether the program is a potential MDAP or MAIS. In preparing the MNS, the originator should document deficiencies in current capabilities, identify applicable operational constraints, identify the projected threat environment, and avoid delineating a system-specific solution.

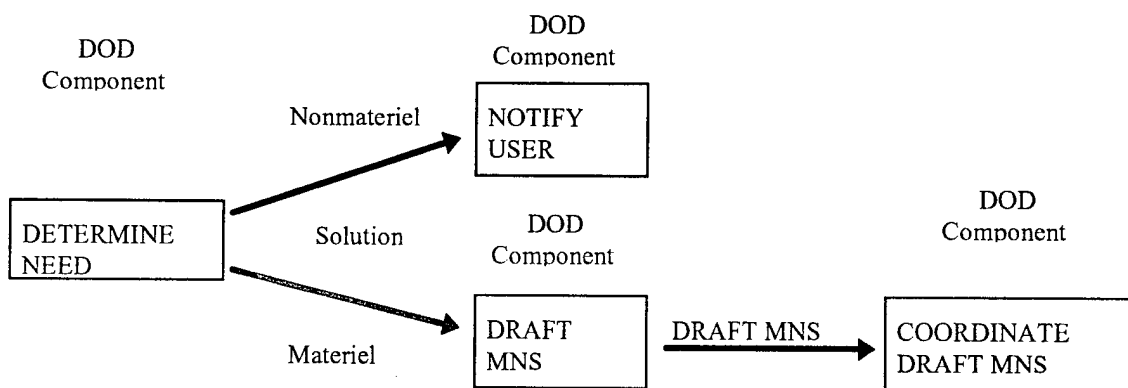

Figure 5. MNS Documentation Phase

c. MNS Validation Phase. Validation of a MNS confirms that the mission need exists and cannot be satisfied by a nonmateriel solution (see Figure 6). As a minimum, the operational validation authority reviews the MNS, confirms that a nonmateriel solution is not feasible, assesses the Joint Service potential, and forwards the MNS with a recommendation to the milestone decision authority (MDA) for Milestone 0 action. Validation is conducted by an authority other than the user, and may take place at different organizational levels depending on MNS origination and potential program ACAT level. The JROC will validate all potential ACAT I and identified special interest MNSs. The Chiefs or DOD component heads (or as delegated) will validate their own potential ACAT II and III MNS. If the potential solution could result in a new ACAT IA, the appropriate OSD Principal Staff Assistant (PSA) or the JROC will review the documented need, determine its validity, establish joint potential, and confirm that the requirements defined in DODD 8000.1 (reference h) have been met.

The JROC Secretary will evaluate all potential Major Automated Information System (MAIS) IA programs and determine if JROC oversight is appropriate or desired. DOD components should forward all potential ACAT IA MNSs and ORDs to the JROC Secretariat for assessment. Potential MAIS programs not reviewed by the JROC remain under the purview of the initiating agency and its PSA.

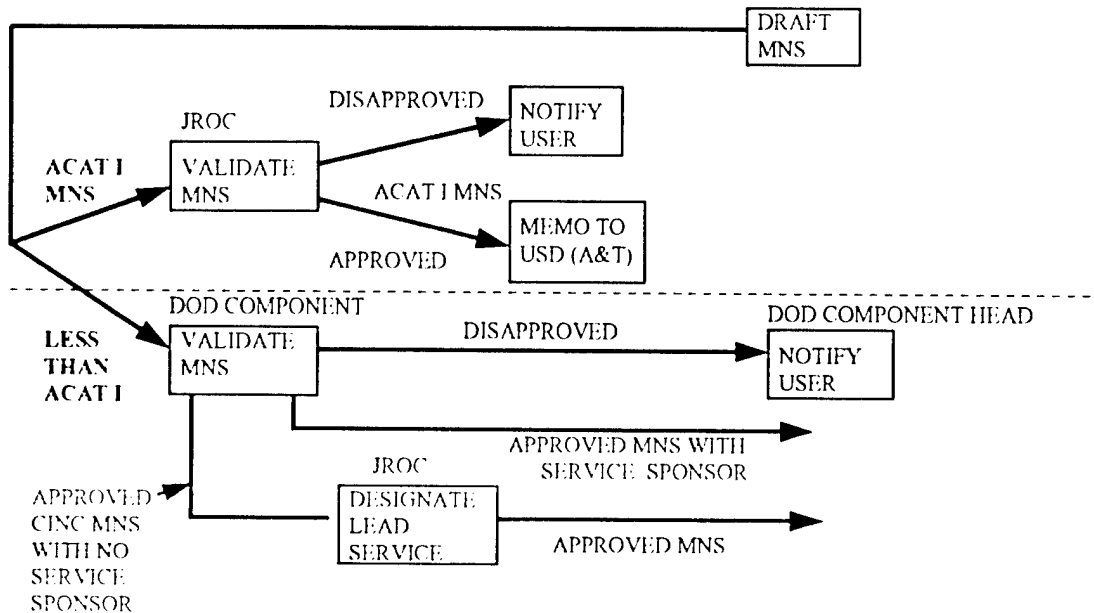

Figure 6. MNS Validation Phase

d. MNS Approval Phase. The approval authority for all potential ACAT I and identified special interest MNSs is the JROC. The approval authority for all potential ACAT IA MNSs is the PSA or JROC. For Service or DOD component-generated potential ACAT II and III MNSs, the Chief of the Service, director of a DOD component, or delegated authority is the approval authority (see Figure 7). The approval authority will indicate a joint potential designator (JPD) in the MNS and may recommend the lead Service or agency for programs involving more than one DOD component (see subparagraphs 3f and 3g). For potential ACAT ID programs, approved MNSs are forwarded to the USD(A&T) for follow-on DAB consideration. For potential ACAT IA programs, approved MNSs are forwarded to the ASD(C3I) for follow-on MAISRC considerations. ACAT II and III MNS are forwarded to the component acquisition executive.

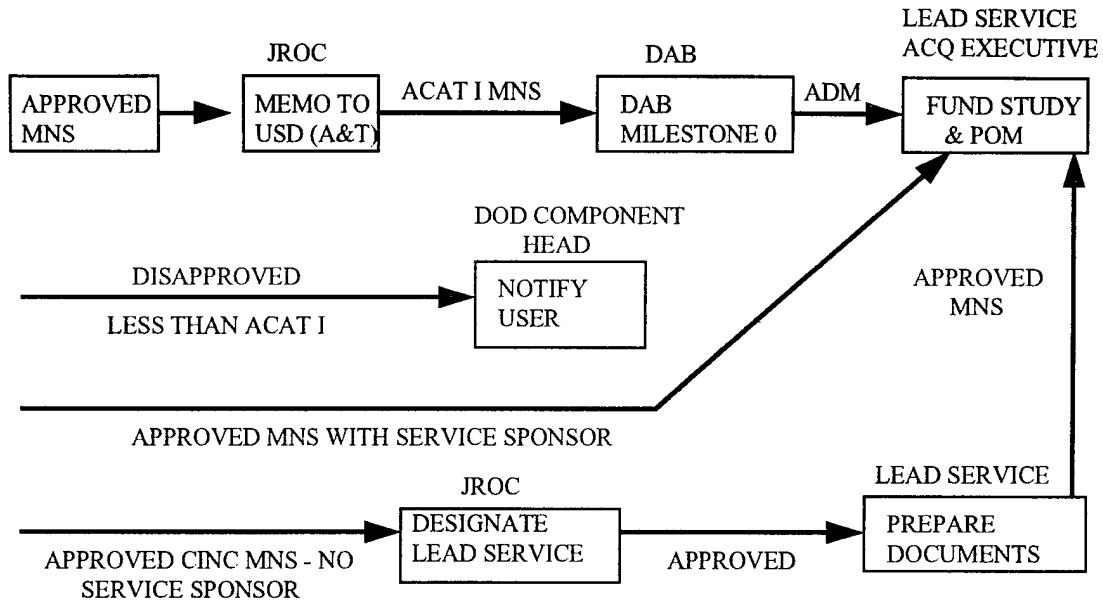

Figure 7. MNS Approval Phase

e. MNS Review Process. The following procedures describe the process used by the JROC Secretariat to obtain MNS validation and approval. Any MNS forwarded for JROC validation is considered to be a draft MNS. The JROC will staff all potential ACAT I and identified special interest MNSs (and ACAT IA, as appropriate) to the CINCs, Services, Joint Staff, and appropriate DOD agencies for review (see Figure 8). DOD components should use similar procedures to ensure harmonization of potential ACAT II and III MNSs (procedures and timelines for review are nominal and may be modified to meet program demands). The following are JROC MNS processing procedures and timelines:

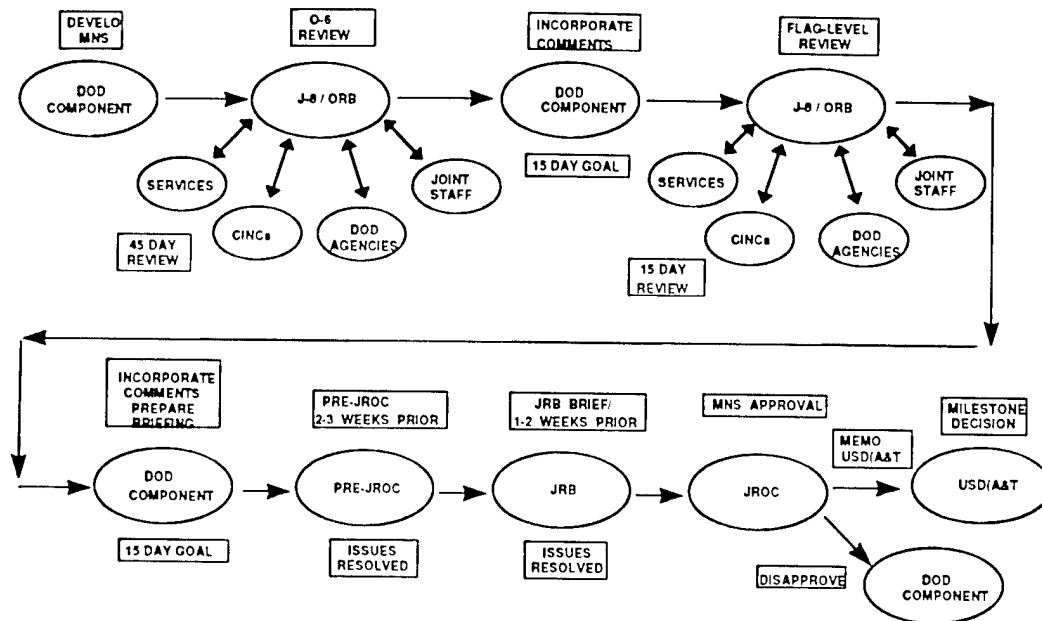

Figure 8. MNS Review Process

Step (1) The Joint Staff Operational Requirements Branch (J-8/ORB) will verify format for accuracy and completeness and staff the draft MNS via JROC staff memorandum (JROCSM) for CINC, Service, Joint Staff, and appropriate DOD agency O-6 level review. The suspense date for providing comments to J-8/ORB will normally be 45 days from transmittal date. This review will include initial C4 interoperability (J-6), intelligence supportability (DIA), and munitions interoperability/insensitivity (J-4) certification. No response by the suspense date without a request for extension will be considered concurrence.

Step (2) J-8/ORB will compile and forward all comments back to the sponsoring DOD component via JROCSM for incorporation or revision, as necessary.

Step (3) Following incorporation or revision of O-6 level review comments, the sponsor should forward the draft MNS to J-8/ORB. Upon receipt, J-8/ORB will again verify format for accuracy and completeness and restaff the draft MNS for Service, CINC, Joint Staff, and appropriate DOD agency flag-level review via JROCSM. This review will include final C4 interoperability (J-6), intelligence supportability (DIA), and munitions interoperability/insensitivity (J-4) certification. For this review, the sponsoring DOD component will provide a matrix delineating the disposition of critical and substantive comments received

during O-6-level review. The suspense date for providing comments and/or concurrence back to J-8/ORB will normally be 15 days from transmittal date.

Step (4) Upon receipt of comments, J-8/ORB will compile and forward all comments back to the sponsor via JROCSM for final incorporation or revision. (Note: Should an MNS sponsor disagree with incorporation of a critical comment received during flag level review, they should attempt to reach a mutually agreeable solution prior to forwarding the revised MNS to the JROC. If resolution of the issue is not possible, the issue will be briefed to the JRB for resolution or forwarded to the JROC).

Step (5) Following incorporation of flag-level review changes, the MNS sponsor should schedule pre-JROC, JROC Review Board (JRB), and JROC briefings with the JROC Secretariat. The pre-JROC will normally be convened 2 to 3 weeks before the JROC and the JRB will normally convene 1 to 2 weeks before the JROC.

Step (6) Following JROC review, the JROC Chairman will forward a recommendation, including a Joint Potential Designator and lead Service recommendation, via JROC memorandum (JROCM) to USD(A&T) for consideration during the DAB or ASD(C3I) for the MAISRC.

f. Joint Potential Review/Designation. Individually and collectively, the Joint Staff, Services, and Defense agencies will examine joint component applicability for each MNS before Milestone 0, each proposed new start acquisition program at Milestone I, and each ongoing acquisition program at Milestones II and III. The MNS sponsor will assess the joint potential of its MNS as part of the validation process by coordinating the MNS with the Services. The sponsoring component will assign a Joint Potential Designation (JPD) of independent, joint interest, or joint (as defined in Enclosure C of this instruction) based on the input received during Service coordination. After MNS validation, the validation authority will include the assigned JPD in the recommendation to the MDA. The JROC review process accomplishes this JPD coordination for potential ACAT I and appropriate IA programs. DOD components accomplish this JPD coordination for ACAT II and III programs.

g. Designation of Lead DOD Component. Joint programs require the designation of a lead DOD component by the MDA. The MDA makes the decision based on the recommendation of the JROC for DAB

programs or of the Chief of the Service or DOD component head (or as designated) for all other programs. The responsibilities of the lead component are described in reference b, part 3, subparagraph 3.3.5.3, "Joint Program Management." The JROC will include its lead Service or agency recommendation to USD(A&T) for approved potential ACAT I MNS with joint potential and ASD(C3I) for appropriate ACAT IA MNS. DOD components lacking an acquisition structure and unable to obtain Service support (e.g., unified commands (other than USSOCOM), Joint Staff, and some Defense agencies) may forward potential ACAT II and III validated and approved MNSs to the JROC. The JROC will coordinate designation of a lead Service or agency and forward the MNS to that Service's MDA for action. A DOD agency (e.g., DISA) may be designated as lead component.

h. MNS Retirement. In the event a JROC approved MNS is superseded or the mission need no longer exists, an MNS can be brought to the JROC for formal retirement. Requests for retiring an MNS, with justification, should be forwarded to the JROC Secretariat for staffing.

4. Capstone Requirements Documents (CRDs). A CRD can be used to identify overarching requirements for a system, or several programs that form a system-of-systems. The CRD serves as a guide for future ORD development and a vehicle for program oversight. The CRD format is in Enclosure C.

a. CRD Definition Phase: The CRD acts as a bridge between the MNS and program ORDs for mission areas with common tasks or programs that form a systems-of-systems. The CRD should be developed after the overall MNS is validated and prior to Milestone I. A CRD is appropriate when the mission area requires more than one ORD, especially when these systems are developed by more than one Service. The CRD identifies overarching system requirements for a broad mission need (surveillance, missile defense, etc.). The JROC will designate the lead agency to best represent overarching requirements for a "system-of-systems" CRD.

b. CRD Documentation Phase: A CRD is a document that contains performance-based requirements to facilitate development of individual ORDs by providing a common framework and operational concept to guide their development. It provides guidance to support ORD development and further provides a vehicle for the JROC to maintain oversight of the mission area systems. The CRD should identify the Key Performance Parameters (KPPs) that are essential for

13 June 1997

mission success of a system-of-systems. The applicable CRD KPPs should also be reflected in the ORDs for the programs that fall under the CRD. The CRD is a living document and should be periodically reviewed and updated. Because ORDs are also living documents, the CRD KPPs should incorporate, as applicable, the KPPs that are developed in the individual program ORDs. The ORD will remain the defining acquisition document for system development and testing.

c. CRD Validation and Approval Phases: The JROC has validation and approval authority for all ACAT I and appropriate ACAT IA CRDs. The JROC may delegate approval authority to a Service or DOD component in some cases. During the validation and approval phases, the JROC may provide recommendations for program ORD development. The JROC can use the CRD as a "checklist" to ensure that system requirements are addressed by the program ORDs.

d. CRD Review Process. The CRD review procedures are the same as those used for the ORD and are described in subparagraph 5e.

#### 5. ORD Preparation Procedures

a. ORD Definition Phase. As part of the evolutionary requirements process that begins with the mission need, the user or user's representative will apply the results of cost-schedule-performance tradeoffs made during the Concept Exploration Phase of the acquisition process to identify operational parameters. These parameters are the operational requirements that best characterize the most promising concept(s) to be pursued in the Program Definition and Risk Reduction Phase of a new acquisition program approved at Milestone I. They are documented by the user's representative, normally a Service or Service component of a combatant command, in the ORD.

b. ORD Documentation Phase. The ORD provides a bridge that links the MNS and CRD (if applicable) to the Acquisition Program Baseline (APB) and the contractual specifications. The initial ORD will establish objective values and minimum acceptable operational values (thresholds) for broad (high level) performance parameters describing the system capabilities and characteristics of the proposed concepts. The ORD should be written at the appropriate level to describe the concept and is initially submitted at Milestone I with broad objectives and minimum acceptable requirements. If the program falls under a CRD, the ORD should show traceability to the CRD KPPs and requirements. The results of the evaluation of the commercial market

potential survey will be included as part of the initial ORD (reference b, part 2, subparagraph 2.3.1, "Evaluation of Requirements Based on Commercial Market Potential," and title 10, United States Code, section 2377).

(1) Key Performance Parameters (KPPs). KPPs are those performance parameters validated by the JROC (ACAT I, appropriate ACAT IA, and identified special interest programs) or PSA (other ACAT IA programs) and approved by the MDA that will be included in the APB. They are those capabilities or characteristics considered most essential for successful mission accomplishment. KPPs are expressed as thresholds and objectives. Failure to meet a KPP threshold can be cause for the concept or system selection to be reevaluated or the program to be reassessed or terminated. KPPs are extracted from the ORD and included in the APB and each Milestone beginning with Milestone I. KPPs validated by the JROC or by a PSA may not be traded off without JROC approval or PSA review (reference b, part 3.2.1, "Objectives and Thresholds"). User or user representative participation in each acquisition phase is essential (reference b, part 2.3, "Requirements Evolution," and part 3.2.2.2, "APB Content"). The following guidelines should be applied when selecting KPPs:

- Is it essential for defining system or required capabilities?
- Is it warfighting oriented?
- Is it achievable/testable?
- Can the numbers/percentages be explained by analysis?
- If not met, are you willing to look at canceling the program?

(2) Thresholds and Objectives. A threshold is the minimum acceptable value below which the utility of the system becomes questionable; i.e., the concept or system selection is reevaluated or the program is reassessed or terminated. APB thresholds establish deviation limits beyond which the program manager may not trade off cost, schedule, or performance without authorization from the MDA and ORD approval authority. An objective is a value beyond the threshold that could potentially have a measurable and beneficial impact on capability or operations and support. KPPs should be expressed with both thresholds and objectives.

c. ORD Validation Phase. The JROC will review and validate potential ACAT I, ACAT ID, and appropriate ACAT IA performance thresholds and objectives listed as KPPs in the ORD. They will also review the performance section of the APB at each successive

13 June 1997

milestone review, or if a KPP is changed at any time during the life of a program. The JROC maintains validation authority for ACAT ID or appropriate ACAT IAM ORDs even if approval authority has been delegated. Other MAIS programs remain under the purview of the initiating agency and are validated by its PSA. The Chiefs or DOD component heads (or as delegated) may validate their own ACAT IC, IAC, II and III ORDs. The JROC forwards its validation and recommendations to the USD(A&T) as part of the DAB process or ASD(C3I) for the MAISRC. For ACAT IC, II, and III programs, a Service or DOD component ORD validation authority should submit its validations to the appropriate MDA.

d. ORD Approval Phase. The approval authority for all potential ACAT I ORDs is the JROC. The approval authority for all potential ACAT IA ORDs is the PSA or JROC. The JROC will normally delegate ORD approval authority for ACAT ID and appropriate ACAT IAM ORDs to the lead Service or DOD Component at the Milestone I JROC review. For some ACAT I and ACAT IA programs, the JROC may retain approval authority or designate this function to a specific CINC or PSA. For Service or DOD component-generated ACAT IC, IAC, II, and III ORDs, the Chief of the Service, director of DOD component, or delegated authority is the approval authority. Approved ORDs are submitted by the approval authority to the appropriate MDA for action.

e. ORD Review Process. The following procedures describe the process used by the JROC Secretariat to staff and coordinate ORDs and are very similar to the MNS procedures. Any ORD forwarded for JROC validation is considered to be a draft ORD. The JROC will staff all potential ACAT I, appropriate ACAT IA, and identified special interest ORDs to the CINCs, Services, Joint Staff, and appropriate DOD agencies for review. DOD components should use similar procedures to ensure harmonization of all other potential ACAT II and III ORDs (procedures and timelines for review are nominal and may be modified to meet program demands). Once a program has been designated, the JROC will staff ACAT ID/IAM and special interest ORDs and the responsible DOD component or agency will staff all others. The following are JROC ORD processing procedures and timelines:

Step (1) The Joint Staff Operational Requirements Branch (J-8/ORB) will verify format for accuracy and completeness and staff the draft ORD via JROCSM for CINC, Service, Joint Staff, and appropriate DOD agency 0-6 level review. The suspense date

for providing comments to J-8/ORB will normally be 45 days from transmittal date. This review will include initial C4 interoperability (J-6), intelligence supportability (DIA), and munitions interoperability/insensitivity (J-4) certification. No response by the suspense date without a request for extension will be considered concurrence.

Step (2) J-8/ORB will compile and forward all comments to the sponsoring DOD component via JROCSM for incorporation or revision, as necessary.

Step (3) Following incorporation or revision of O-6 level review comments, the sponsor should forward the draft ORD to J-8/ORB. Upon receipt, J-8/ORB will again verify format for accuracy and completeness and restaff the draft ORD via JROCSM for Service, CINC, DIA, and Joint Staff flag-level review. This review will include final C4 interoperability (J-6), intelligence supportability (DIA), and munitions interoperability/insensitivity (J-4) certification. As with the MNS review, the sponsoring DOD component will provide a matrix delineating the disposition of critical and substantive comments received during O-6-level review. The suspense date for providing comments and/or concurrence back to J-8/ORB will normally be 15 days from the transmittal date.

Step (4) Upon receipt of comments, J-8/ORB will compile and forward all comments back to the sponsor via JROCSM for final incorporation or revision. (Note: Should an ORD sponsor disagree with incorporation of a critical comment received during flag-level review, they should attempt to reach a mutually agreeable solution prior to forwarding the revised ORD to the JROC. If resolution of the issue is not possible, the issue will be briefed to the JRB for resolution or forwarded to the JROC.)

Step (5) Following incorporation of flag-level review changes, the ORD sponsor should schedule pre-JROC, JRB, and JROC briefings with the JROC Secretariat. The pre-JROC will normally convene 2 to 3 weeks before the JROC, and the JRB will normally convene 1 to 2 weeks before the JROC. The JROC should convene at least 30 days prior to the DAB/MAISRC to allow adequate time for Integrated Product Team (IPT) review between the JROC and the DAB/MAISRC.

13 June 1997

Step (6) Following JROC review, the JROC Chairman will forward a Milestone review and lead Service recommendation, including a list of Key Performance Parameters, to USD(A&T) via JROCM for consideration during the DAB or ASD(C3I) for the MAISRC. If a special interest program is not going to a DAB or MAISRC, the recommendations will be forwarded to the appropriate milestone decision authority. If appropriate, the JROC Chairman will also delegate ORD approval authority to the lead component.

f. Multiple Systems. Because mission needs may be fulfilled by single or multiple systems by a program, it may be appropriate to tailor the ORD to encompass the multiple systems. The ORD sponsor should determine which elements of the ORD format should be used to ensure that the overall system capabilities and characteristics are defined to a level adequate to generate lower-level system ORDs. Ultimately, an ORD should be developed for each system.

g. ORD Updates. The ORD is refined and updated at each milestone to incorporate results of the activities during each acquisition phase (i.e., cost, schedule, and performance trades, testing, and analysis of alternatives (AOA)). There is no need to update the MNS because the ORD builds upon this initial document. The ORD should be thoroughly reviewed by the user, user's representative, and ORD validation and approval authorities--with assistance from the development and test communities--to ensure the deficiencies and requirements are still valid when compared to the latest threat, guidance, and strategy documents. Also, the ORD should be vigorously scrubbed to ensure that the KPPs reflect the minimum essential requirements. KPPs validated by the JROC or by a PSA may not be traded off without JROC approval or PSA review.

h. Measures of Effectiveness (MOEs). MOEs should be developed, when appropriate, to quantify how well alternatives satisfy the operational need qualitatively described in the MNS. These MOEs, generally system-level engagement or battle outcomes, should be described in the initial ORD and may be included in the Acquisition Program Baseline at Milestone I. The MOEs play a vital part in linking the AOA, APB, ORD, and Test and Evaluation Master Plan (TEMP). Because MOEs are rarely amenable to end-to-end tests, the capabilities (measures of performance) and characteristics (design features) in the initial and subsequent ORDs should be refined to a level of specificity that allows development and operational testing to

verify that the system has met its required operational effectiveness and suitability.

6. Acquisition Program Baseline (APB) Procedures. The APB contains the cost, schedule, and key performance parameters for the program. APBs are described in reference b, section 3.2.2. With progression through the requirements evolution and acquisition milestone process, the APBs will change focus from concept (Milestone I) to development (Milestone II) to production (Milestone III). KPPs from the ORD, combined with cost and schedule measures, will be included within the APB with their associated objectives and thresholds. Objectives equal or exceed the thresholds with an affordable, operationally meaningful, and cost-effective increment in capability above the threshold. APBs are prepared by the program manager with user inputs using the format specified in Appendix I to reference b. APBs are submitted with the required milestone documentation for Milestone I and each succeeding milestone. The KPPs objectives and thresholds in the APB must be validated by the appropriate authority before the MDA's review. The JROC is the validation authority for ACAT ID and appropriate ACAT IA KPPs found in the APB/ORD. Validation is normally accomplished during the ORD review. The MDA is the approval authority for all APBs in accordance with reference b, section 3.2.2.1, "Preparation and Approval." Before all major milestone decision reviews for ACAT ID and appropriate ACAT IAM programs and for all APB changes, the JROC will review the APB's cost, CAIV objectives, schedule, and key performance parameters (objectives and thresholds) to ensure they satisfy the mission need (reference b, section 3.2.2.2).

7. Nontraditional Acquisition Programs. The formal acquisition process is the primary mechanism for the procurement of new or upgraded military capabilities. Requirements documents are required and tied to all phases of the formal acquisition process. However, nontraditional acquisitions (e.g., Advanced Concept Technology Demonstrations (ACTDs), etc.) may not have formal requirements documentation. When a nontraditional acquisition program transitions to the formal acquisition process, the JROC and DAB/MAISRC will define what requirements documents are required. Programs that anticipate transitioning to the formal acquisition process should start development of requirements documents early to ensure a smooth transition to the formal acquisition process.

13 June 1997

## ENCLOSURE B

## MISSION NEED STATEMENT FORMAT

Mission Need Statements for all acquisition categories will be uniform across DOD components in accordance with the following format and no longer than 5 pages.

MISSION NEED STATEMENT  
FOR  
(TITLE OF OPERATIONAL CAPABILITY NEED)

1. Defense Planning Guidance Element. Identify the major program planning objective or section of the Defense Planning Guidance to which this need responds. Also reference the Joint Intelligence Guidance and DOD or Military Department long-range investment plans, if applicable.
2. Mission and Threat Analyses. Identify and describe the mission need or deficiency. Define the need in terms of mission, objectives, and general capabilities. Do not discuss the need in terms of equipment or system-specific performance characteristics. Discuss the Defense Intelligence Agency (DIA)-validated threat to be countered as well as the projected threat environment and the shortfalls of existing capabilities or systems in meeting these threats. Comment on the timing of the need and the general priority of this need relative to others in this mission area.
3. Nonmateriel Alternatives. Discuss the results of the mission area analysis. Identify any changes in US or allied doctrine, operational concepts, tactics, organization, and training that were considered in the context of satisfying the deficiency. Describe why such changes were judged to be inadequate.
4. Potential Materiel Alternatives. Identify known systems or programs addressing similar needs that are deployed or are in development or production by any of the Services or allied nations. Discuss the potential for inter-Service or allied cooperation. Indicate potential areas of study for concept exploration including the use of existing US or allied military or commercial systems or product improvements of existing systems. Do not evaluate these alternatives.
5. Constraints. Describe, as applicable, key boundary conditions related to infrastructure support that may impact on satisfying the need:

logistics support; transportation; global geospatial information and services support; manpower, personnel, and training constraints; command, control, communications, and intelligence interfaces; security; and standardization or interoperability within DOD components, NATO, and other allies and friendly nations. Address the operational environments (including conventional; initial nuclear weapon effects; nuclear, biological, and chemical contamination (NBCC); electronic; and natural) in which the mission is expected to be accomplished. Define the level of desired mission capability in these environments.

6. Joint Potential Designator. Indicate the Joint Potential Designator established through the validation process.

For MAIS programs, the following additional information should be incorporated in the MNS format:

Defense Planning Guidance Element: Describe how the mission need relates to the OSD Principal Staff Assistant's (PSA's), DOD Chief Information Officer's, and the DOD component's strategic planning.

Mission and Threat Analyses: Describe the functional area or activity the MNS supports, and the functional area or activity's current organization and operational environment, with emphasis on existing functional processes, including the concept of operation of the existing functional processes, procedures, and capabilities. Describe the shortfalls of existing capabilities.

Constraints: Identify the classification level(s) and level of assurance required for the system. Describe the anticipated system security, systems interface(s), and interoperability requirements, if known. Include information warfare in the discussion of operational environments in which the mission is expected to be accomplished.

13 June 1997

## ENCLOSURE C

## CAPSTONE REQUIREMENTS DOCUMENT FORMAT

Capstone Requirements Documents for all acquisition categories will be uniform across DOD components in accordance with the following format:

## CAPSTONE REQUIREMENTS DOCUMENT

FOR

(PROGRAM TITLE)

1. General Description of Operational Capability. Describe the overall mission area, the type of system proposed, and the anticipated operational and support concepts in sufficient detail for program, logistics, and other support planning. Include a brief summary of the mission need. If a documented mission need did not precede the Capstone Requirements Document, explain the process that investigated alternatives for satisfying the mission need and developing operational requirements.
2. Threat. Summarize the threat to be countered and the projected threat environment. This threat information should reference Defense Intelligence Agency or Service Technical Intelligence Center-approved documents and be validated by the Service Intelligence Director. For major defense acquisition programs (ACAT I), reference the Defense Intelligence Agency (DIA)-validated threat assessment. In some nonwarfighting systems, the threat may be listed as not applicable.
3. Shortcomings of Existing Systems. Describe why existing systems cannot meet current or projected requirements (do not describe a proposed system).
4. Capabilities Required. Identify operational performance parameters (capabilities and characteristics) required. Articulate requirements in operational, results-oriented, and measurable terms. Specify each performance parameter in terms of a minimum acceptable value (threshold) required to satisfy the mission need. Objectives, if stated, should represent a measurable, beneficial increase in capability or operations and support above the threshold. If an objective is not stated, it is assumed to be the same as the threshold.

- a. System Performance. Describe mission scenarios (wartime and peacetime, if different) in terms of mission profiles, employment tactics, countermeasures, and environmental conditions (all inclusive: natural and man-made, e.g., weather, ocean acoustics, information warfare).
  
- b. Identify system performance parameters such as range, accuracy, payload, speed, mission reliability, etc. Recommend which parameters should be considered key performance parameters.

ENCLOSURE D

REFERENCES

- a. DOD Directive 5000.1, 15 March 1996, "Defense Acquisition."
- b. DOD Regulation 5000.2-R, 15 March 1996, "Mandatory Procedures for Major Defense Acquisition Programs (MDAPs) and Major Automated Information System (MAIS) Acquisition Programs."
- c. Title 10, United States Code, sections 151, 153, 154, 155, 161, 162, 163, 166, 167, 181, 3013, 5013, and 8013.
- d. CJCSI 5123.01, 2 May 1997, "Charter of the Joint Requirements Oversight Council."
- e. DOD Instruction 4630.8, 18 November 1992, "Procedures for Compatibility, Interoperability, and Integration of Command, Control, Communications, and Intelligence (C3I) Systems."
- f. CJCS Instruction 6212.01A, 30 June 1995, "Compatibility, Interoperability, and Integration of Command, Control, Communications, Computers, and Intelligence Systems."
- g. JROCM-032-97, 31 March 1997, "JROC Administrative Guide."
- h. DOD Directive 800.1, 27 October 1992, "Defense Information Management (IM) Program."

(INTENTIONALLY BLANK)

GLOSSARY

PART I--ABBREVIATIONS AND ACRONYMS

ACAT	Acquisition Category
ACTD	Advanced Concept Technology Demonstration
AOA	Analysis of Alternatives
APB	Acquisition Program Baseline
ASD(C3I)	Assistant Secretary of Defense (Command, Control, Communications and Intelligence)
C4	command, control, communications, and computers
C4I	command, control, communications, computers, and intelligence
C4ISR	command, control, communications, computers, intelligence, surveillance, and reconnaissance
CAIV	cost as an independent variable
CRD	Capstone Requirements Document
DAB	Defense Acquisition Board
DIA	Defense Intelligence Agency
DODD	Department of Defense Directive
DPG	Defense Planning Guidance
IPT	Integrated Product Team
JPD	Joint Potential Designator
JRB	JROC Review Board
JROC	Joint Requirements Oversight Council
JROCM	JROC memorandum

JROCSM	JROC Staff memorandum
KPP	Key Performance Parameter
MAA	Mission Area Analysis
MAIS	Major Automated Information System
MAISRC	Major Automated Information System Review Council
MCEB	Military Communications-Electronics Board
MDA	Milestone Decision Authority
MDAP	Major Defense Acquisition Program
MIB	Military Intelligence Board
MNS	Mission Need Statement
MOE	measure of effectiveness
NATO	North Atlantic Treaty Organization
NBCC	nuclear, biological, and chemical contamination
POC	point of contact
PSA	Principal Staff Assistant
ORB	Operational Requirements Branch
ORD	Operational Requirements Document
RDT&E	research, development, test, and evaluation
TEMP	Test and Evaluation Master Plan
USD(A&T)	Under Secretary of Defense for Acquisition and Technology
USSOCOM	United States Special Operations Command

## PART II--DEFINITIONS

Acquisition Category (ACAT). Categories established to facilitate decentralized decision making and execution, and compliance with statutorily imposed requirements. The categories determine the level of review, decision authority, and applicable procedures. DOD 5000.2-R, part 1, provides the specific definition for each acquisition category (ACAT I through III).

ACAT 1D. A major defense acquisition program subject to Defense Acquisition Board oversight and estimated by the USD(A&T) to require an eventual total expenditure of more than \$355,000,000 in RDT&E funds, or \$2,135,000,000 in procurement funds measured in FY1996 constant dollars.

ACAT IA. A major automated information system acquisition program that is estimated to require program costs in any single year in excess of \$30,000,000, total program costs in excess of \$120,000,000, or total life cycle costs in excess of \$360,000,000 (FY 1996 constant dollars).

ACAT IAM. A major automated information system acquisition program that is subject to Major Automated Information System Review Council oversight.

Acquisition Program Baseline (APB). Developed and updated by the program manager, each baseline will govern the activity in the phase succeeding the milestone for which it was developed. The Concept Baseline, Development Baseline, and Production Baseline are prepared at Milestone I, II, and III, respectively. APBs consist of three parts: section A--performance (contains KPPs), section B--schedule, and section C--cost.

Advanced Concept Technology Demonstration (ACTD). A means of demonstrating mature technology to address critical military needs. ACTD's are not acquisition programs, although they are designed to provide a residual, usable capability upon completion.

Approval. The formal or official sanction of the identified need described in the requirements documentation. Approval also certifies that the documentation has been subject to the uniform process established by DOD 5000 series.

Analysis of Alternatives (AOA). The evaluation of the estimated costs and operational effectiveness of alternative material systems to meet a

mission need. The AOA assists decision makers in selecting the most cost-effective material alternative to satisfy a mission need.

Certification. Coordination provided by a responsible agency for a specific area of concern in support of the validation process.

Capstone Requirements Document (CRD). A document that contains performance-based requirements to facilitate development of individual ORDs by providing a common framework and operational concept to guide their development.

DOD Component. OSD, the Military Departments, the Chairman of the Joint Chiefs of Staff (Joint Staff), the unified and specified commands (including US Element, NORAD), Defense agencies, and DOD field activities.

DOD 5000 Series. Refers collectively to DODD 5000.1 and DOD 5000.2-R.

Implementation. The publication of directives, instructions, regulations, and related documents that define responsibilities and authorities and establish the internal management processes necessary to implement the policies or procedures of a higher authority.

Joint Potential Designator (JPD). Used to describe the expected level of joint DOD component involvement.

- a. Independent. No potential for other Service use or systems interface or for joint development or procurement.
- b. Joint Interest. Joint program management is inappropriate, but a potential for other Service use or systems interface exists (formerly interoperating).
- c. Joint. A potential for joint program management, joint funding, and/or joint development or procurement exists.

Joint Requirements Oversight Council Memorandum (JROCM). Official JROC correspondence generally directed to an audience(s) external to the JROC. Usually decisional in nature.

Joint Requirements Oversight Council Staff Memorandum (JROCSM). Official JROC correspondence generally utilized for internal staffing and

13 June 1997

tasking. Usually predecisional in nature and not releasable outside of JROC circles.

Key Performance Parameters (KPPs). Those performance parameters validated by the JROC and included in the APB. They are those capabilities or characteristics considered most essential for successful mission accomplishment. Failure to meet a KPP threshold can be cause for the concept or system selection to be reevaluated or the program to be reassessed or terminated.

Lead DOD Component. The Service or agency that has been formally designated as lead for a joint program by the MDA. The lead component is responsible for all common documentation, periodic reporting, and funding actions.

Major Automated Information System (MAIS) Program. An automated information system acquisition program that is estimated to require program costs in any single year in excess of \$30,000,000, total program costs in excess of \$120,000,000, or total life cycle costs in excess of \$360,000,000 (FY 1996 constant dollars).

Major Defense Acquisition Program (MDAP). An acquisition program that is not a highly sensitive classified program and is estimated by the USD(A&T) to require an eventual total expenditure of more than \$355,000,000 in RDT&E funds, \$2,135,000,000 in procurement funds, measured in FY 1996 constant dollars, or programs designated as an MDAP by the USD(A&T).

Materiel Solution. A defense acquisition program (non-developmental, modification of existing systems, or new program) that satisfies identified mission needs.

Milestones. Major decision points that separate the phases of an acquisition program.

Military Department. Headed by a civilian Secretary appointed by the President and includes a Military Service (the Department of the Navy includes two Services).

Military Service. Headed by a uniformed member who reports to the civilian Secretary heading the Military Department of which the Service is a part.

Mission Area Analysis (MAA). A process by which warfighter deficiencies are determined, technological opportunities for increased system effectiveness and/or cost reduction are assessed, and mission needs are identified.

Mission Need. A deficiency in current capabilities or an opportunity to provide new capabilities (or enhance existing capabilities) through the use of new technologies. They are expressed in broad operational terms by the DOD components.

Mission Need Statement (MNS). A formatted non-system-specific statement containing operational capability needs and written in broad operational terms. It describes required operational capabilities and constraints to be studied during the Concept Exploration and Definition Phase.

Nonmajor Defense Acquisition Program. Does not meet criteria for a MDAP. Further defined as ACAT II or III in DOD 5000.2-R, part 1.

Nonmateriel Solution. Changes in doctrine, tactics, training, or organization to satisfy identified mission needs. MNSs with an identified nonmateriel solution are sent to the Military Departments for consideration and action.

Objective. An operationally significant increment above the threshold. An objective value may be the same as the threshold when an operationally significant increment above the threshold is not significant or useful.

Operational Requirements. A system capability or characteristic required to accomplish approved mission needs. Operational (including supportability) requirements are typically performance parameters, but they may also be derived from cost and schedule. For each parameter, an objective and threshold value must also be established.

Operational Requirements Document (ORD). A formatted statement containing performance and related operational parameters for the proposed concept or system. Prepared by the user or user's representative at each milestone beginning with Milestone I, Concept Demonstration Approval.

Operational Validation Authority. Designated authority responsible for confirming the user's identified need and operational requirement. Designation of this operational validation authority is the responsibility

of the MDA and will vary between DOD components and the ACAT level of the program.

Operator. An operational command or agency that employs the acquired system for the benefit of users. Operators may also be users.

Originator. A DOD component or operational command that initiates a MNS. The originator may or may not be the sponsor.

Principal Staff Assistant (PSA). Represents the user community in the functional area under their direction on acquisition and requirements matters. The OSD PSAs are the Under Secretaries of Defense (USDs), the Director of Defense Research and Engineering (DDR&E), the Assistant Secretaries of Defense (ASDs), the Director, Operational Test and Evaluation (DOT&E), the General Counsel of the Department of Defense (GC, DOD), the Inspector General of the Department of Defense (IG, DOD), the Assistants to the Secretary of Defense (ATSDs), and the OSD Directors, or equivalents, who report directly to the Secretary or the Deputy Secretary of Defense.

Requirement. The need of an operational user, initially expressed in broad operational capability terms in the format of a MNS. It progressively evolves to system-specific performance requirements in the ORD.

Sponsor. The DOD component responsible for all common documentation, periodic reporting, and funding actions required to support the requirements and acquisition process.

Supplementation. The publication of directives, instructions, regulations, and related documents that add to, restrict, or otherwise modify the policies or procedures of a higher authority.

System Capabilities. Measures of performance such as range, lethality, maneuverability, and survivability.

System Characteristics. Design features such as weight, fuel capacity, and size. Characteristics are usually traceable to capabilities (e.g., hardening characteristics are derived from a survival capability) and are frequently dictated by operational constraints (e.g., carrier compatibility) and/or the intended operational environment (e.g., NBC).

Threshold. A minimum acceptable operational value below which the utility of the system becomes questionable.

User. An operational command or agency that receives or will receive benefit from the acquired system. CINCs and their Service component commands are the users. There may be more than one user for a system. The Service component commands are seen as users for systems required to organize, equip, and train forces for the CINCs. The Chiefs of the Services and heads of other DOD components are validation and approval authorities and are not viewed as users.

User Representative. A command or agency that has been formally designated by proper authority to represent single or multiple users in the requirements and acquisition process. The Services and the Service components of the CINCs are normally the user representatives. There should only be one user representative for a system.

Validation. The review of documentation by an operational authority other than the user to confirm the need or operational requirement. As a minimum, the operational validation authority reviews the MNS, confirms that a nonmateriel solution is not feasible, assesses the joint Service potential, and forwards a recommendation to the MDA for Milestone 0 action. Validation is a necessary, but not sufficient, step for approval. This step appears identical to approval in the case of a MNS, but the JROC may delegate final ORD approval authority while retaining validation authority.