

REPORT DOCUMENTATION PAGE			Form Approved OMB NO. 0704-0188	
Public reporting burden for this collection of information is estimated to average 1 hour per response, including the time for reviewing instructions, searching existing data sources, gathering and maintaining the data needed, and completing and reviewing the collection of information. Send comment regarding this burden estimate or any other aspect of this collection of information, including suggestions for reducing this burden, to Washington Headquarters Services, Directorate for Information Operations and Reports, 1215 Jefferson Davis Highway, Suite 1204, Arlington, VA 22202-4302, and to the Office of Management and Budget, Paperwork Reduction Project (0704-0188), Washington, DC 20503.				
1. AGENCY USE ONLY (Leave blank)	2. REPORT DATE 9/26/97	3. REPORT TYPE AND DATES COVERED Final Progress 5/15/94-6/30/97		
4. TITLE AND SUBTITLE Fluorescent Diagnostics and Fundamental Droplet Processes		5. FUNDING NUMBERS DAAH04-94-G-0020		
6. AUTHOR(S) Lynn A. Melton		8. PERFORMING ORGANIZATION REPORT NUMBER		
7. PERFORMING ORGANIZATION NAMES(S) AND ADDRESS(ES) University of Texas at Dallas Box 830688 Richardson, TX 75083-0688		10. SPONSORING / MONITORING AGENCY REPORT NUMBER ARO 32517, 2-EG		
9. SPONSORING / MONITORING AGENCY NAME(S) AND ADDRESS(ES) U.S. Army Research Office P.O. Box 12211 Research Triangle Park, NC 27709-2211		11. SUPPLEMENTARY NOTES The views, opinions and/or findings contained in this report are those of the author(s) and should not be construed as an official Department of the Army position, policy or decision, unless so designated by other documentation.		
12a. DISTRIBUTION / AVAILABILITY STATEMENT Approved for public release; distribution unlimited.				
13. ABSTRACT (Maximum 200 words) This project is directed toward the development and use of fluorescent diagnostics in the understanding of the heating and evaporation of droplets and sprays. (1) At the University of Texas at Dallas (UTD), a major focus has been the determination of the transient temperature field within droplets which fall into hot ambient gas. Oxygen resistant high temperature fluorescence shift thermometers were studied and the oxygen quenching behavior of a previously studied fluorescent thermometry system (PYPYP) was characterized. Other fluorescent diagnostics work, including studies of the evaporation of liquid fuel films and characterization of fuel/methanol mixtures have accompanied this focus on fundamental studies of droplet heating. (2) At United Technologies Research Center (UTRC), the major focus has been the design and operation of a droplet slicing imaging experiment to determine conclusively the role of aerodynamic-induced shear forces, especially at high pressures, in causing internal circulation within droplets. UTRC has also investigated diagnostics appropriate for study of liquid instabilities near the critical point. These experiments utilized acoustic disturbances in UTRC's high pressure pulse tube facility and Raman imaging to obtain images of O2 in and around a LOX droplet stream.				
14. SUBJECT TERMS droplets, fluorescence, internal circulation, diagnostics, heating, evaporation		15. NUMBER OF PAGES 47		
		16. PRICE CODE		
17. SECURITY CLASSIFICATION OR REPORT UNCLASSIFIED		18. SECURITY CLASSIFICATION OF THIS PAGE UNCLASSIFIED	19. SECURITY CLASSIFICATION OF ABSTRACT UNCLASSIFIED	20. LIMITATION OF ABSTRACT UL

19971204 108

DTIC QUALITY INSPECTED 4

I. STATEMENT OF PROBLEM STUDIED

This project is directed toward the development and use of fluorescent diagnostics in the understanding of the heating and evaporation of droplets and sprays.

At the University of Texas at Dallas (UTD), a major focus has been the determination of the transient temperature field within cold droplets which fall into hot ambient gas. In the program for carrying out these measurements, oxygen resistant high temperature fluorescence shift thermometers were studied and the oxygen quenching behavior of a previously studied fluorescent thermometry system (PYPYP) was characterized. Other fluorescent diagnostics work, including studies of the evaporation of liquid fuel films and characterization of fuel/methanol mixtures have accompanied this focus on fundamental studies of droplet heating.

At United Technologies Research Center (UTRC), the major focus has been the design and operation of a droplet slicing imaging experiment to determine conclusively the role of aerodynamic-induced shear forces, especially at high pressures, in causing internal circulation within droplets. UTRC has also investigated diagnostics appropriate for study of liquid instabilities near the critical point. These experiments utilized acoustic disturbances in UTRC's high pressure pulse tube facility and Raman imaging to obtain image of O₂ in and around a LOX droplet stream.

II. SUMMARY OF MOST IMPORTANT RESULTS

This section summarizes the accomplishments at UTRC. UTRC has provided a separate report on its accomplishments under the subcontract from UTD. The UTRC report is incorporated as ATTACHMENT 1 to this Final Report and should be read as part of this section on Most Important Results.

At UT-Dallas, the transient temperature field within a 0.5 mm diameter droplet, which has been injected as a cold droplet into high temperature nitrogen, has been reproducibly imaged using combined droplet slicing imaging (DSI)/exciplex fluorescence thermometry (EFT) techniques.

This work built on a succession of accomplishments under previous ARO funding (1983-present): exciplex fluorescence thermometry (UTRC and UTD), droplet thermometry (UTD), droplet slicing imaging (UTRC), and restoration of DSI images (UTD). In this experiment, a room temperature decane droplet, which had been doped with the PYPYP EST (exciplex shift thermometry) system, fell into hot (400-500 C) nitrogen. It was intercepted by a narrow laser sheet, which "sliced" through the equatorial plane of the droplet.

The resulting fluorescence was made to form two images on a CCD camera, which images were filtered to isolate two distinct wavelength regions in the PYPYP fluorescence. Restoration of both images, pixel-by-pixel ratioing of the two images, and conversion of the ratios using laboratory calibrations yielded a temperature image. The images were taken as a function of the distance the droplet has fallen since entering the high temperature region. The images generally showed that the temperature field inside the droplet rapidly became almost homogeneous and this homogeneous temperature rose towards the boiling point of the droplet.

Experiments were completed to determine whether PYPYP, used as an exciplex shift thermometer (EST) (the exciplex band shifts to higher energy as a function of temperature), is oxygen independent. The working hypothesis was that earlier data, which showed a slight dependence of the calibration curve on oxygen concentration, were flawed, and that the system is truly independent of oxygen concentration. The earlier data were taken slowly and part of the PYPYP may have reacted with oxygen to form other fluorescent species. The new calibration/test experiments were performed quickly, i.e., heating and measurement times of only a few seconds rather than hours. If the reactions with oxygen take longer than a few seconds, then it would have been possible to use PYPYP as an EST for droplets, since typical lifetimes for evaporating droplets are less than 1 second. The EST calibration experiments were carried out on a time scale which was fast compared to the oxygen reaction time, and, unfortunately for this diagnostic, the calibration experiments showed that oxygen quenching effects are inherent and are present independently of the oxygen reaction effects.

The characterization of series of strongly fluorescent compounds whose total fluorescence is virtually independent of temperature and oxygen was completed. These compounds can serve as fluorescent mass markers. However, they are relatively involatile and cannot be used for tracking the mass of hydrocarbon fuel on an engine port or cylinder walls. For some of these compounds, the fluorescent band shifts significantly with temperature and thus they can be used as thermometers. A possible application is in determining the temperature of the oil film on an engine cylinder wall.

Two cyclic ketones have been identified which are virtually co-evaporative with automotive gasoline and whose fluorescence is virtually independent of temperature and oxygen concentration have been identified (work jointly supported by Ford Motor Company). These compounds can be used as fluorescent mass markers. Calibration experiments,

in which the fluorescence intensity as a function of liquid film thickness was measured, have been carried out.

A fluorescent compound whose fluorescent shifts strongly as a function of the concentration of methanol in hydrocarbon fuel (automotive gasoline) has been identified. It could serve for rapid determination of methanol concentration in (unknown) gasolines. Tests were carried out to determine whether water in gasoline could also cause such a fluorescence shift, an effect which would interfere with the projected use. Water does not interfere but the additive package in different commercial gasolines does interfere.

III. LIST OF PUBLICATIONS AND TECHNICAL REPORTS

1. T. J. Anderson, R. D. Woodward, and M. Winter, "Oxygen Concentration Measurements in a High Pressure Environment Using Raman Imaging", AIAA 33rd Aerospace Sciences Meeting, Reno, NV, January 9-12, 1995, AIAA 95-0140
2. L. A. Melton, "Planar Liquid and Gas Visualization", AT-Process, Journal of Process Analytical Chemistry, 227 (1996).*
3. T. Q. Ni and L. A. Melton, "2-D Gas Phase Temperature Measurement Using Fluorescence Lifetime Imaging", Applied Spectroscopy, 50, 1112 (1996).
4. L.A. Melton, "Use of Fluorescence methods for Measurement of Droplet and Vapor Temperature", Recent Advances in Spray Combustion (American Institute of Aeronautics and Astronautics Progress Volume), edited by K.O. Kuo, Volume I, Chapter 6, 143 (1996).
5. J. H. Stufflebeam and M. Winter, "Optical Diagnostics for Internal Flow in Fuel Droplets", AIAA 34th Aerospace Sciences Meeting, Reno, NV, January 15-18, 1996, AIAA 96-0464.
6. T. J. Anderson, M. Winter, and M. Haas, "Observation of Droplet/Shock Interactions in a Supercritical Environment", AIAA 34th Aerospace Sciences Meeting, Reno, NV, January 15-18, 1996, AIAA 96-0557.
7. Fenglian Bai and L. A. Melton, "High Temperature Oxygen Resistant Molecular Fluorescence Thermometers", Applied Spectroscopy, accepted for publication in 9/97 issue)

* Mentioned in Final Report for DAAL03-91-G-0033

IV. PARTICIPATING SCIENTIFIC PERSONNEL

1. Lynn A. Melton, principal investigator
Professor of Chemistry
University of Texas at Dallas
2. Michael Winter
Manager, Advanced Optical Diagnostics
United Technologies Research Center
(through subcontract to UTRC)
3. John Stufflebeam
Senior Research Scientist
United Technologies Research Center
(through subcontract to UTRC)
4. Torger J. Anderson
Senior Research Scientist
United Technologies Research Center
(through subcontract to UTRC)
5. Yadong Zhao
graduate student
M.S in Chemistry awarded 1996
6. Jiemin Yang
graduate student
Doctor of Chemistry degree expected January 1998
7. Jean Martino
graduate student
Doctor of Chemistry degree expected June 1998
8. Sandra Wang
undergraduate student (Summer)
B.A., 1997 (Wellsley College)
9. Fenglian Bai
postdoctoral scientist
10. Qingzheng Lu
postdoctoral scientist

V. REPORT OF INVENTIONS

No inventions were developed during this period.

ATTACHMENT 1

FLUORESCENT DIAGNOSTICS & FUNDAMENTAL DROPLET PROCESSES

- I. LASER DIAGNOSTICS OF FUNDAMENTAL PROCESSES IN
DROPLETS
- II. LIQUID INSTABILITY TECHNOLOGY - DIAGNOSTICS AND
MEASUREMENTS

Final Report of
UTRC Contract SC94-06
To The University of Texas at Dallas

September, 1997

I. LASER DIAGNOSTICS OF FUNDAMENTAL PROCESSES IN DROPLETS

SUMMARY

UTRC has undertaken a study of internal, shear-induced droplet motion using planar laser-induced fluorescence in a diagnostic technique called droplet slicing. Shear-induced, internal motion affects the mass and thermal transport properties which may enhance evaporation rates and chemical reaction times. Experiments are described that utilize 2-D images of laser-induced fluorescence from equatorial planes in the droplets to measure flow and temperature patterns. The slicing experiments have been performed in cold-flow, inert conditions and extended to a combustion environment. Further extension to a high pressure combustion regime was accomplished. The experiments utilized an aerodynamic droplet generator and an analytical model of its performance was used to design an unambiguous experiment to elucidate shear-induced internal circulation by providing flow conditions that result in shear reversal during the droplet trajectory. The final phase of this contract was directed toward developing experiments to measure and understand strain and strain rate in the primary atomization of liquid fuel sprays.

The major highlights of research conducted under this contract are:

- Inverse ray tracing routinely applied to correct images for the droplet lens effect.
- Acetone seeding eases slicing technique by removing restriction on oxygen-free environment.
- Mathematical model developed for aerodynamic droplet generator and used for experimental design
- Droplet slicing images obtained at elevated temperature and pressure in flame environment.

RESEARCH GOALS

The specific research goals of this contract were:

Task I - Single Droplet Slicing Measurements

- a. UTRC shall perform experiments directed at the characterization of shear-induced internal motion in single droplets by means of imaging laser-induced fluorescence from planes which are on and off 90° to measure flow and temperature patterns within the droplets. These experiments will be designed in such a way that the source of detected flow patterns will be unambiguous as possible, to provide data for direct comparison to model predictions being carried out by other researchers in the field.
- b. UTRC shall attempt to extend the above-mentioned measurements to elevated temperatures by performing measurements on droplets in a heated environment or in a combustion environment, in order to test model predictions of the dependence of these processes for droplets in a combustion environment.

- c. UTRC shall perform the above-mentioned measurements on evaporating and/or burning multi-component droplets, in order to test model predictions of the dependence of micro explosions and disruptive boiling events on the degree of internal circulation.
- d. UTRC shall extend the above mentioned measurements to elevated pressures, possibly as high as 30 atmospheres in order to test model predictions relating aerodynamic drag on the pressure dependence of these processes for diesel and/or gas turbine applications.
- e. UTRC will attempt to extend high temperature, high pressure fluorescence-based droplet measurements to regimes approaching or above the critical temperature of selected fuels in order to explore droplet behavior under these conditions.

Task II - Droplet -Turbulence Interactions and Spin

- a. UTRC shall attempt to investigate droplet -turbulence interactions by performing measurements of the flow patterns inside single droplets imbedded in jet flow. Gas-phase jet flow will be visualized by planar laser-induced fluorescence, while liquid flow patterns will be measured using fluorescence quenching and droplet slicing techniques.
- b. UTRC shall attempt to investigate the effects of shear flow and velocity gradients on droplet internal flow structure and the influence on droplet spin by combining an aerodynamic droplet generator, planar laser-induced fluorescence to characterize the gas phase flow, and droplet slicing techniques to visualize flow patterns within the droplets. The purpose of these measurements is to understand and quantify the mechanisms which cause droplet spin, to ascertain the relevance for diesel and/or gas turbine applications to aid in modeling of these processes.

TECHNICAL ACCOMPLISHMENTS

Task I a and II a: Images acquired in previous experiments (under ARO contracts DAAL02-87-K-0120 and DAAL03-91-G-0033) were corrected for the lens effect of the hemispherical droplet medium. A computer program, developed for this purpose by Dr. Jingyi Zhang of The University of Texas at Dallas, was adapted and compiled on a VAX computer at UTRC and applied to droplet image libraries. Experiments were performed with the aerodynamic droplet generator configured to produce decane droplets with acetone condensed on their surface. The drops were allowed to fall into an ambient atmosphere. Laser excitation at 266 nm induces fluorescence from the acetone while the decane is not excited. Internal circulation was observed as the acetone was convected inwards from the surface. Because the acetone fluorescence is not sensitive to oxygen quenching, special requirements, e.g. dry nitrogen background (as for exciplex fluorescence), were not needed and the ambient gas was normal room air. This represents a significant simplification of droplet slicing experiments. Signal levels increase as droplets progress downstream because the acetone concentrations increase as the droplet falls. It should be noted however, that the types of response corrections that are typically done are not possible, since the absorption of light within the droplet depends on the acetone concentration and distribution

Task I b - c: Experiments of droplet flow patterns and heat transfer effects as the drops are subjected to sudden temperature changes were performed and the results published in AIAA paper 96-0464 which is attached in Appendix A of this report. The drops were injected into the fuel flow of a methane/air diffusion flame and traveled through the flame front where they experienced a rapid temperature rise in their environment

Task I d - e: The flame stability was characterized and results depicted in the following figure. These data demonstrate the fuel/air schedule required to achieve flame pressures of over 12 atmospheres. The Nitrogen is used as a diluent to control flame temperature and sooting.

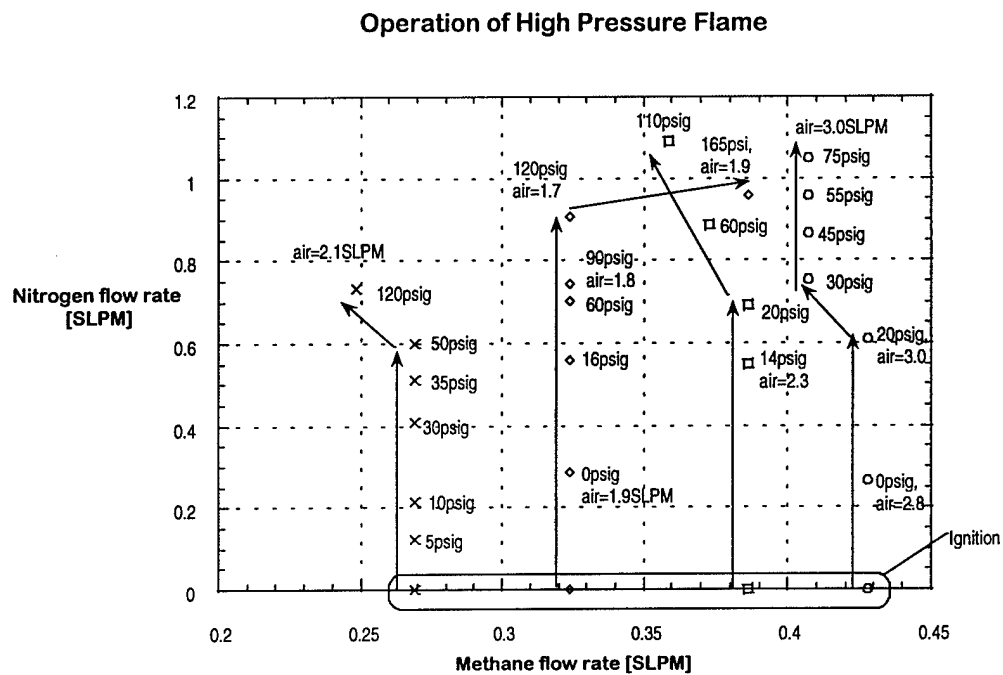

Stable trajectories are required for reproduction of droplet position and to maintain the droplet image within the camera field of view as the droplet is tracked higher above the nozzle orifice. Stable trajectories were achieved to 3.5 atmospheres. Motion of the injector tip caused by flow perturbations limited the stability of trajectories. The data in the next figure show the conditions for droplet injection that were achieved.

Droplet slicing experiments were performed in the inside (core region) of the non-premixed flame. Droplets were injected into the fuel flow of a methane/air diffusion flame and traveled through the flame core where they experienced a rapid temperature rise in their environment. Shown in Figure 3 are bicomponent (acetone/decane) droplet images from the flame at atmospheric pressure and slightly elevated pressure (1.8 atm).

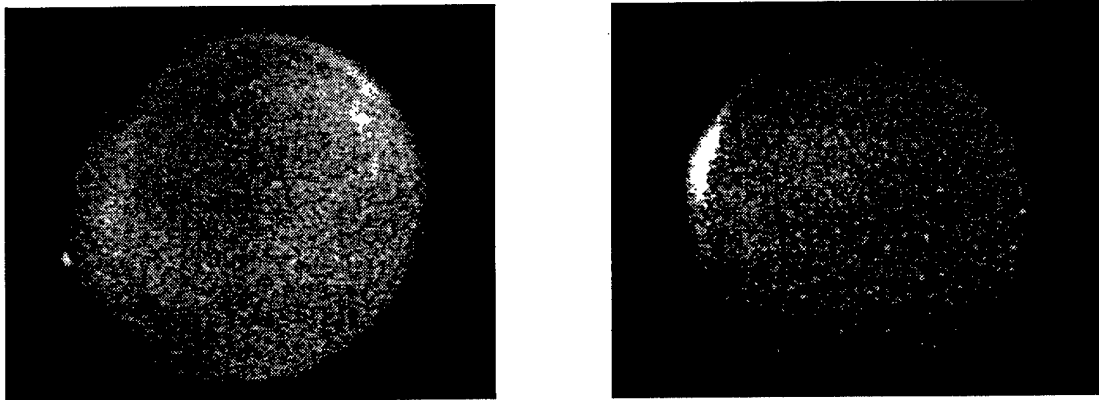
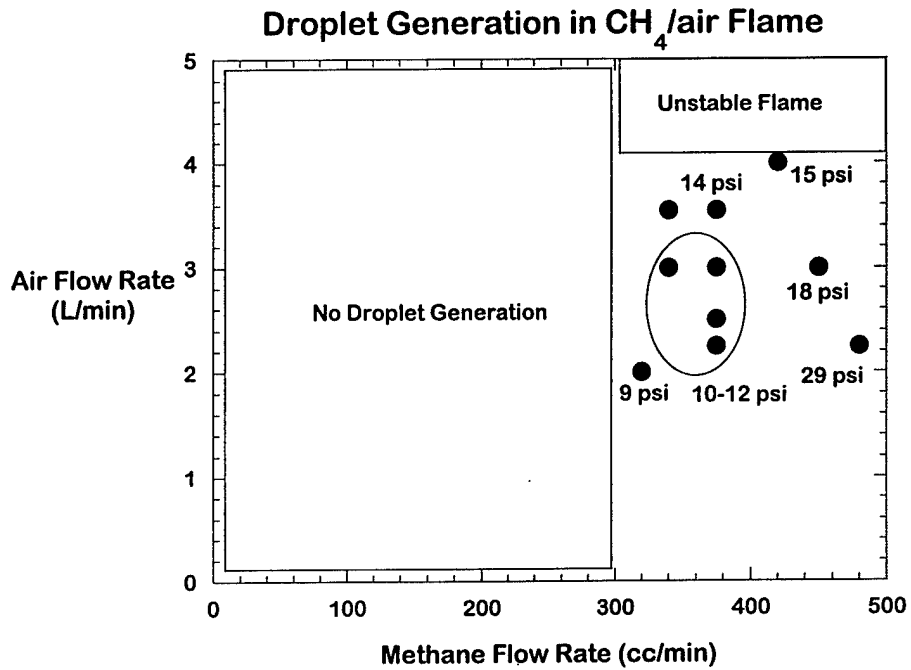

Figure 3. Droplet Slicing images from bicomponent drops in CH₄/air non-premixed flame.
 (a) 1.0 atm, (b) 1.8 atm.

Task II b: The concepts for experiments to measure the shear, velocity gradients and strain rate in the primary atomization zone of liquid fuel sprays is detailed in the abstract for the June 1997 AFOSR Contractors Meeting. This abstract is included as Appendix B of this report.

CONCLUSIONS

Droplet slicing is an effective approach to study details of thermal/mass transport in individual fuel drops. An experimental facility was developed to investigate the internal flow of droplets using laser fluorescence techniques. As an example, droplet shear was analytically modeled and compared to experimental results. The model was used to design experimental conditions for further study in high pressure flames. The aerodynamic droplet generator was incorporated in a nonpremixed methane/air burner and successfully operated up to 12 atmospheres. The stability of droplet trajectories limited the useful pressure range for droplet slicing measurements to 3.5 atmospheres. Experimental concepts to measure droplet shear, velocity gradients and strain rate were developed.

II. LIQUID INSTABILITY TECHNOLOGY - DIAGNOSTICS AND MEASUREMENTS

SUMMARY

The objective of this program was to develop spectroscopic diagnostics for droplets and sprays undergoing critical-point phase transitions and provide data including densities, concentrations temperatures and critical-surface tracking under steady state conditions and in the presence of large acoustical disturbances. The final task of this program was altered to investigate the use of magnetic fields to control and direct liquid oxygen droplet streams for the purpose of controlling liquid instabilities in rocket engines.

The diagnostic development task led to the use of Raman scattering to image O₂ concentration in and around a LOX droplet stream at critical and supercritical conditions. The application of this technique to LOX droplet streams in an acoustic environment was not achieved due to difficulties with the laser and droplet generator systems.

The final task incorporated both experimental and analytical elements to investigate the feasibility of using magnetic fields to control LOX sprays in a rocket environment. The conclusion arrived at was that the concept was not capable of producing the necessary force with conventionally-run magnetic fields. The use of superconductor magnetic fields was not investigated.

RESEARCH GOALS

The specific research goals of this contract were:

Task I - Diagnostic Development

- a. UTRC shall use its high pressure pulse tube facility to acquire data describing droplet breakup and distribution in critical and supercritical environments as a result of acoustic disturbances. Initial measurements will include back-lit images of droplets following an initial period after the disturbance.
- b. Consideration was to be made to generate continuously-varying and repetitive conditions, rather than step change disturbances through the use of an acoustic driver.

Task II - Diagnostic Application to Supercritical conditions

- a. Develop a diagnostic technique with the ability to acquire quantitative data describing droplet breakup in a supercritical environment.

Task III - Evaluation of Magnetic Control of a Liquid Oxygen Stream

- a. Determine the capability of a magnetic field to control a liquid oxygen stream under conditions existing at the point of injection in a liquid-fueled rocket engine.

TECHNICAL ACCOMPLISHMENTS

Task I

An initial effort was spent acquiring images of LOX droplets interacting with strong acoustic fields using Schlieren and backlit imaging time-phased with the passage of a shock wave in the UTRC high pressure facility. The results of these experiments were included as part of a paper presented at the 1994 AIAA Aerospace Sciences Meeting. This paper is included with this report as appendix C.

Task II

The task began with the development of a planar imaging diagnostic to measure O_2 concentration in a supercritical environment and applying it to droplet streams in static high pressure sub- and supercritical environments. The work was partially supported by Roger D. Woodward, a visiting scientist from the Air Force Phillips Laboratories who was funded directly from that agency. The work culminated in results described in a paper presented at the 1995 AIAA Aerospace Sciences Meeting. This paper is included as appendix D.

The continued effort was an attempt to apply the Raman experience gained earlier to shock tube measurements to identify and quantify the mechanisms leading to droplet breakup and evaporation in the shock/droplet interaction occurring in a supercritical environment. A high pressure shock tube facility at UTRC was to be used with a LOX droplet generator developed in Task I. The Raman diagnostic was to be modified with the use of a dye laser with a longer pulse capable of generating a signal of equivalent intensity of that of the Nd:YAG laser used in the static environment. This would avoid the potential for droplet breakdown associated with the high instantaneous power of the Nd:YAG laser. Significant difficulties were encountered in getting the droplet generator to perform properly and problems with the dye laser prevented its operation until this funding element was depleted. As a result, no actual measurements of O_2 concentration were made in this part of the program.

Task III

The objective of this task was altered from that in the original statement of work to an evaluation of the potential for active control of liquid propellant combustion by altering the flow of liquid oxygen with magnetic fields.

The magnetic susceptibility of O_2 makes it possible to affect the direction of a liquid oxygen stream with a strong magnetic field. The ability of a conventionally-generated magnetic field to deflect a stream of LOX droplets was studied under this task

An experiment was conducted as illustrated in the figure below. A strong magnetic field with a large gradient was created using a wedge-shaped electromagnet. A LOX stream with droplets approximately 0.2 mm in diameter was directed through the gradient in the direction of increasing magnetic field strength using a droplet generator developed in Task I. The trajectory of the LOX droplet stream was such that the droplets came within 7 mm of the maximum field gradient. The LOX droplet stream was projected onto a polycarbonate shield, placed 13 inches from the orifice of the LOX generator and the deflection of the stream caused by the magnetic field was measured.

Magnetic deflection of the LOX droplet stream was clearly observed. However, as higher LOX velocities are produced with larger pressure differences ranging from .3 to 1.4 atm across the droplet generator, the measured deflection decreases, as shown in Table 1. (The magnetic field strength was held constant at 0.43 Tesla.) Conversely, an analysis of the affect of varying the magnetic field over a reasonable range was made with LOX velocities representative of those in a rocket engine LOX combustor. Table 2 shows the calculated deflection of a LOX droplet stream with a velocity of 75 m/s through an electromagnet with a one inch air gap and increasing magnetic field gradient.

<i>Oxygen Pressure (Psi)</i>	<i>Angle of deflection (deg.)</i>
.31	1.76
.54	1.10
.68	0.88
.82	0.66
1.36	0.44

Table 1. Variation in LOX deflection with pressure in oxygen gas stream

<i>Magnetic field strength (Tesla)</i>	<i>Angle of deflection (deg.)</i>
1.0	2.0E-4
1.5	5.6E-4
2.0	9.9E-4
2.5	1.5E-4

Table 2: Variation of deflection with increasing magnetic field.

The conclusion of these tests is that, although a magnetic field can be used to deflect a LOX droplet stream, the effect is not sufficient to control the LOX flow to the degree necessary in a liquid rocket engine application. The behavior of a LOX stream in the field of a superconducting magnet is yet to be studied.

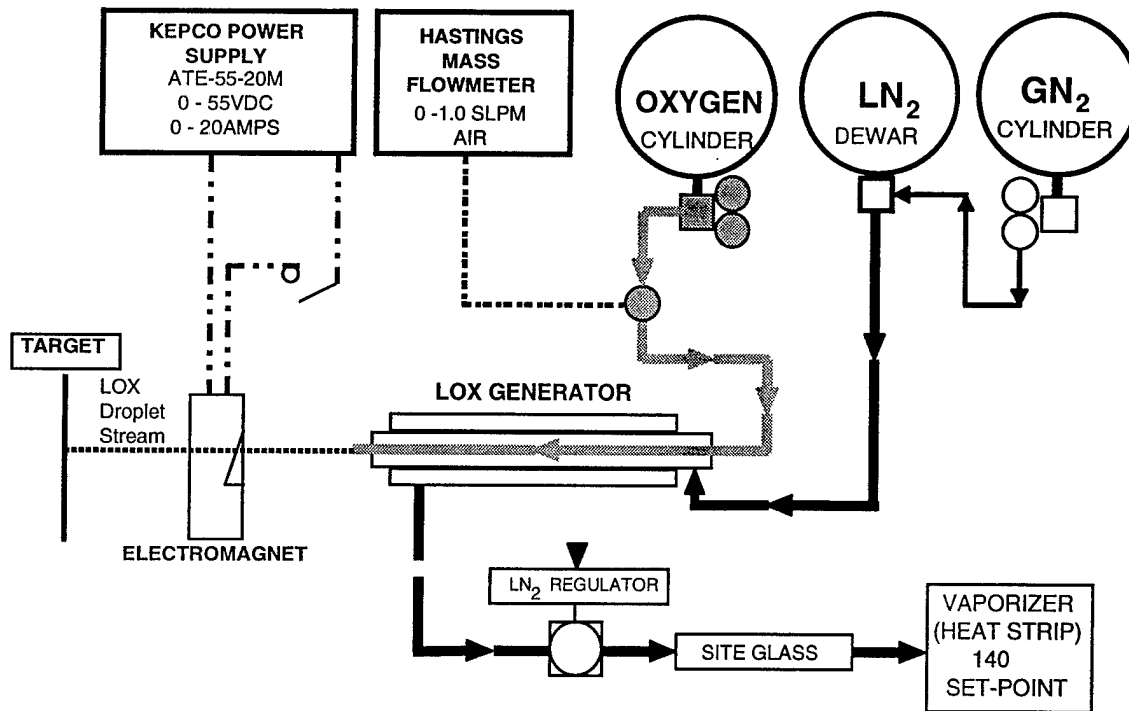

Figure 1. Experimental setup

APPENDIX A

AIAA 96-0464

Optical Diagnostics of Internal Flow in Fuel Droplets

John H. Stufflebeam and Michael Winter

UTRC, East Hartford CT



AIAA 96-0464

**Optical Diagnostics of Internal
Flow in Fuel Droplets**

John H. Stufflebeam and Michael Winter
UTRC
East Hartford, CT

**34th Aerospace Sciences
Meeting & Exhibit**
January 15-18, 1996 / Reno, NV

OPTICAL DIAGNOSTICS OF INTERNAL FLOW IN FUEL DROPLETS*

John H. Stufflebeam[†] and Michael Winter[°]
United Technologies Research Center
East Hartford, CT

Abstract

Shear-induced, internal motion of single fuel droplets affects the mass and thermal transport properties which may enhance evaporation rates and chemical reaction times. Experiments are described that utilize 2-D images of laser-induced fluorescence from equatorial planes in the droplets to measure flow and temperature patterns. The slicing experiments have been performed in cold-flow, inert conditions and extended to a combustion environment. Further extension to a high pressure combustion regime is planned. An analytical model of the aerodynamic droplet generator is used to design an unambiguous experiment to elucidate shear-induced internal circulation by providing flow conditions that result in shear reversal during the droplet trajectory.

Objective

Previously we have shown that an aerodynamic droplet generator can provide a unique platform for studying shear induced internal conditions. The objective of the current study is to quantitatively model the conditions pertaining to the droplet surroundings and the associated shear history experienced by the droplet. The model is then used to design experiments at elevated pressure to tailor the flow history for parametric studies. An experiment for performing droplet slicing measurements at elevated pressure and temperature will also be described. Experimental conditions exceeding the thermodynamic critical temperatures and pressures can be achieved allowing investigation of shear induced internal circulation within droplets at realistic combustor conditions.

Introduction

Understanding the heating and evaporation of fuel sprays is important for the design of gas turbine combustors and diesel engines.^{1,2} The current work investigates the competition between shear and vaporization effects in drops. Attempts to model the heat transfer in complex sprays rely on describing the heat transfer to individual droplets, and therefore, the behavior of individual droplets in a spray combustor is a critical part of the combustion process. This has led to several studies of the heating, evaporation, and burning of isolated droplets in a hot ambient atmosphere.^{3,4} A question that remains in the development of these computational models is the existence and importance of shear-induced internal circulation which can influence the terminal velocity and evaporation rates of droplets whose diameters are a few hundred microns or less.⁵⁻¹¹ Thermal diffusion in the liquid phase is quite slow, but internal circulation involves the convective transport of hot surface liquid to the center of the droplet, heating the core more rapidly.

It has been suggested, that internal circulation may not be present in small droplets (i.e. approx. hundreds of microns).¹² This might be attributable to effects of surface-active substances which would accumulate along the interface between two fluids and thereby lower the surface tension. Recently, we have reported a technique for measuring internal circulation in droplets falling in quiescent room temperature ambient conditions.¹³ Measurement of internal circulation using laser-induced oxygen-quenched fluorescence is currently being pursued under known initial conditions. Decane doped with naphthalene was used to form droplets from either a droplet-on-demand generator, or

* Copyright © 1995 by United Technologies Research Center. Published by the American Institute of Aeronautics and Astronautics, Inc. with permission.

[†] Senior Research Scientist

[°] Manager, Advanced Optical Diagnostics. Member, AIAA.

an aerodynamic droplet generator, which fall a short distance in a chamber filled with a carefully controlled shear flow of nitrogen and a variable amount of oxygen. A thin sheet of ultra-violet light from the fourth harmonic of a Nd:YAG laser illuminates single droplets. A highly-magnified image of the naphthalene fluorescence is recorded digitally using an intensified, two-dimensional, CCD detector interfaced to a laboratory computer. Since oxygen is a strong fluorescence quencher, any liquid volume element which has been exposed to it by surface contact or diffusion suffers a reduction in fluorescence intensity. Convection from the surface due to internal circulation as well as diffusion cause image regions to appear darker. Oxygen-free experiments, variation of droplet *initial* internal flow patterns, and varied shear flow conditions have been used to examine aerodynamic shear-induced internal circulation.

Experimental Diagnostics. Measurements of internal circulation using laser-induced, oxygen-quenched fluorescence is being pursued under known initial conditions. Decane is used to form droplets from an aerodynamic droplet generator. The generated droplets fall or are projected upward a short distance in a chamber filled with a carefully-controlled shear flow of nitrogen and a variable amount of oxygen. A thin sheet of ultra-violet light from the fourth harmonic of a Nd:YAG laser (266 nm) illuminates single droplets. Sheet thickness has been significantly reduced to less than 20 μm by careful selection of a uniform portion of the initial laser beam waist. A Questar QM100, long-working-distance microscope with uv quartz optics, is used to provide high quality images even through the thick windows characteristic of high pressure test vessels. The microscope produces a highly-magnified image of naphthalene fluorescence which is recorded digitally with an intensified, two-dimensional, CCD detector interfaced to a laboratory computer. A low f number microscope is particularly useful in allowing careful quantification of the imaging modulation transfer function that is used for ray tracing corrections on droplet slicing image data.

Each image was recorded after an increasing time delay after the droplet passed a fixed point in the laboratory frame of reference. A history of the droplet motion is then recorded for analysis of internal motion.

Droplet Slicing Background. Fluorescence can be used to track the internal circulation of droplets. Since oxygen is a strong fluorescence quencher, any liquid volume element which has been exposed to it by surface contact or diffusion will suffer a reduction in fluorescence intensity. Convection from the surface due

to internal circulation as well as diffusion cause image regions to appear darker. Oxygen-free experiments provide a baseline case for comparison.

Aerodynamic Droplet Generators. Aerodynamic droplet generators can provide the ability to produce multi-component layered droplets. An important characteristic of these devices is the production of drops with no spin or nascent internal circulation. This is an important initial condition for this study. In an aerodynamic droplet generator the droplet liquid is suspended on the end of a hypodermic needle which is located in the throat of a gas nozzle. The surrounding gas flow strips off the liquid and forms a droplet. In one set of experiments the droplet liquid (decane) was seeded with naphthalene and allowed to fall into an ambient atmosphere. Laser radiation excited fluorescence in the naphthalene which was subsequently quenched by oxygen convected into the interior of the drop from the ambient air. This produces a map of the internal circulation. Reversal of the internal motion was noted as the droplet velocity exceeded the ambient gas velocity from the decaying jet flow of the generator. This shear reversal occurred approximately 36 droplet diameters downstream of the injector orifice. An alternate approach is to use the naphthalene doped decane and seed the gas flow (nitrogen or air) with acetone. This provides the ability to image both the gas flow (acetone) and the streamlines within the droplet (naphthalene fluorescence quenched by oxygen). In another approach the partial pressure of acetone is increased in the surrounding gas flow and pure decane is the liquid. Acetone condenses continuously onto the liquid surface during the suspension and fall, forming in essence "layered droplets". The acetone is subsequently transported into the droplet as a result of internal circulation.

Planar Laser-Induced Fluorescence (PLIF) was used to investigate the properties of the gas-phase flow from the aerodynamic droplet generator. The sheet of 266 nm light was expanded to illuminate the entire jet. PLIF from acetone showed the behavior of the gas phase jet. The partial pressure of acetone seeded into the gas-phase flow, can be controlled by heating the liquid over which the gas passes. This causes noticeable change in the fluorescence patterns in the droplets. Performing controlled experiments with neat decane, (without naphthalene addition), it became clear that the acetone was condensing on the surface of the droplet since decane exhibits no fluorescence when excited at these wavelengths. Controlling acetone partial pressure and the droplet fall speed, (residence time in the jet), directly controls the thickness of an external acetone layer that is deposited on the droplet.

Bicomponent Droplet Fluorescence. "Layered droplets" provide improved droplet slicing imaging. The fluorescence signal is stronger; even though acetone has a much lower quantum yield than naphthalene, it is locally present in a much higher concentration. The contrast and dynamic range are larger since the fluorescence is now viewed against a dark background rather than against a light background as in the conventional "streamlines by oxygen quenching" experiments. Finally, the streamlines themselves are more sharply defined since the diffusion coefficient for acetone in decane is less than that of oxygen in decane.

Experiments were performed¹⁴ with an aerodynamic droplet generator configured to produce decane droplets with acetone condensed on their surface. The drops were allowed to fall into an ambient atmosphere. Laser excitation at 266 nm induced fluorescence from the acetone while the decane was not excited. Internal circulation was observed as the acetone was convected inwards from the surface. Because the acetone fluorescence is not sensitive to oxygen quenching, special requirements, e.g. dry nitrogen background (as for exciplex fluorescence¹⁵), were not needed and the ambient gas was normal room air. The bi-component droplet investigations significantly simplify droplet slicing measurements thereby enabling the next phase of the program; experiments of droplet flow patterns and heat transfer effects as the drops are subjected to sudden temperature changes. The high temperature environment enables the competing mechanism of fuel vaporization and allows experiments to investigate the relative effects between shear and evaporation on the internal circulation of the droplet.

Analytical Model of Droplet Shear

An analytical model of the aerodynamic droplet generator was developed to help design an unambiguous experiment to elucidate shear-induced internal circulation by providing flow conditions that result in shear reversal during the droplet trajectory. Shear reversal was observed in the fluorescent images from the cold flow experiments and its effect on the internal motion of the droplet was studied. This behavior may only result if the droplet velocity which is initially less than the gas velocity, exceeds the gas velocity to allow reversal of flow patterns. Comparison with data from a high temperature environment is desired as well as data from the high pressure regime to more closely simulate conditions within a gas turbine combustor.

The droplet trajectory is calculated from the balance of forces on the drop. The droplet is accelerated by the drag force from the jet flow while gravity acts to decelerate the drop in this configuration. The flow from an axisymmetric jet¹⁶ is composed of a potential core which has a constant velocity that persists for approximately 5-10 orifice diameters downstream. This core region is followed by the axisymmetric decay region where the velocity decays as $(y/a)^{-1}$, 'a' being the orifice diameter.

$$\frac{d}{dt} \left(\frac{dy}{dt} \right) = \frac{A_{\text{drop}} \cdot C_D}{m_{\text{drop}}} \cdot \frac{\rho_M}{2} \cdot \left[u(y) - \frac{dy}{dt} \right]^2 - \frac{\rho_d \cdot g \cdot V_d}{m_{\text{drop}}}$$

C_D is the drag coefficient, a function of Reynolds number and A_{drop} and m_{drop} , are the area and mass of the decane droplet. V_d is the volume of the drop, ρ_d and ρ_M are the densities of decane and methane and, g is the acceleration of gravity. The jet flow velocity is a function of distance from the orifice and is modeled by the function $u(y)$. The nozzle orifice of the droplet generator is 1 mm. The differential equation is solved for the position and velocity of the drop as a function of height above the nozzle orifice.

Comparison with cold flow data. Results are shown in the following figure for isothermal conditions (ejection into ambient air) with a 600 micron diameter decane droplet in a 293 cm³/min methane flow. The droplet is injected upward so gravity is constantly slowing its velocity. The box symbols are experimental measurements from our apparatus and the thin curve is the methane jet velocity. The calculation predicts the droplet trajectory very well. Shear reversal is not predicted, the droplet velocity never exceeds the jet velocity. These data do serve as validation of the analytical model however.

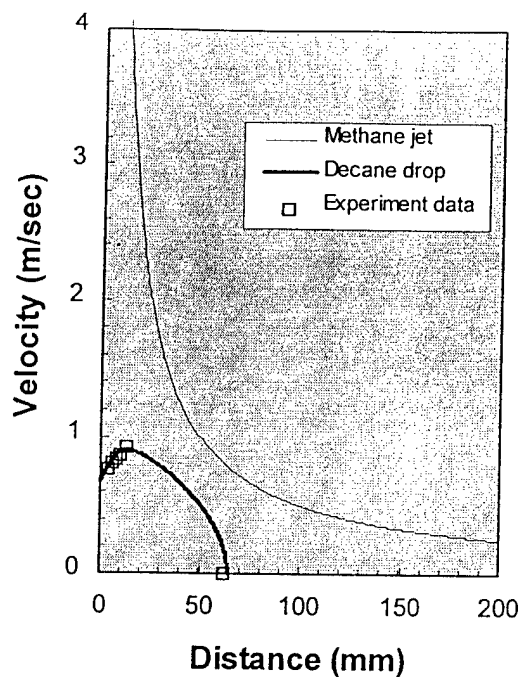

Figure 1. Decane droplet injection with methane jet upward into 1 atmosphere air.

Prediction for flames. Combustion heat release will cause a perturbation of the methane velocity due to the temperature field. The adiabatic flame temperature for methane/air is 2210 K and the flame height is proportional to methane flow rate. Including buoyancy in the calculation produces the result shown in Fig. 2. Again, the droplet is injected upwards to be consistent with the normal operation of laboratory flames. The droplet and methane jet velocities are increased due to the flame heating and their relative velocities are near zero over the region from 20 to 30 cm above the nozzle. The buoyancy has increased the potential for shear reversal but it is not very pronounced and would be difficult to observe experimentally with our technique.

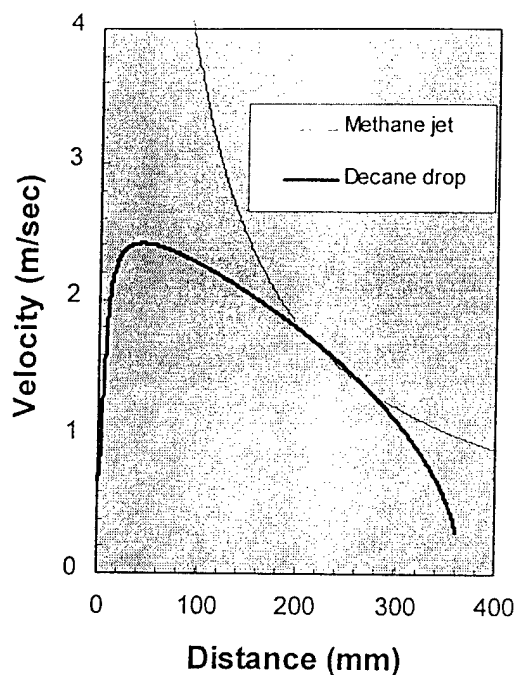

Figure 2. Decane droplet injection with methane jet upward into a 1 atmosphere adiabatic flame environment.

Prediction for high pressure flames. Increasing the pressure has a beneficial effect on the shear velocity; the relative velocities of the drop and methane flow are predicted to reverse 10 cm above the nozzle as shown for 5 atm in Fig. 3. As seen in the figure, this analysis provides the design of an unambiguous experiment to elucidate shear-induced internal circulation by providing flow conditions that result in shear reversal during the droplet trajectory. The model predicts a clearly defined region of shear reversal in flame environments at elevated pressure. This outcome is beneficial to the ultimate goal of the investigation, i.e., droplet studies above the critical conditions of the decane fuel.

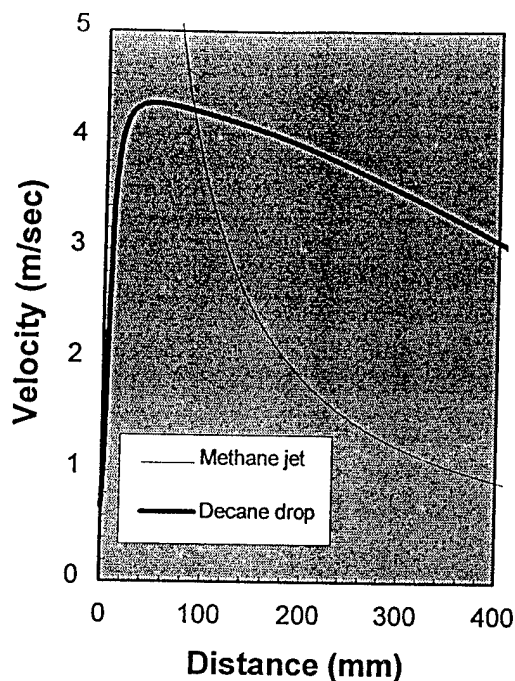

Figure 3. Decane droplet injection with a methane jet upwards into a 5 atmosphere adiabatic flame environment.

Experimental Design

High Pressure Burner. The aerodynamic droplet generator has been incorporated into the design of a jet diffusion flame burner. The major design parameters are shown in Figure 4. The burner is made of quartz and mounted in a high pressure vessel capable of sustaining flames to 20 atmospheres. The decane is gravity-fed to a tapered quartz tube where a droplet is extruded and held by surface tension. The gas fuel (methane) is flowed into the droplet region under pressure and strips the drop, accelerating it through the 2 mm orifice. The methane is saturated with acetone by bubbling the gas through an acetone bath. A provision for nitrogen diluent that will control sooting and flame height is incorporated. The burner has a novel design feature, swirl control tubes, to control the droplet spin induced by the injection process. The spin may be created by the effects of nonuniform throat conditions or, slight misalignment of the droplet delivery tube within the orifice.

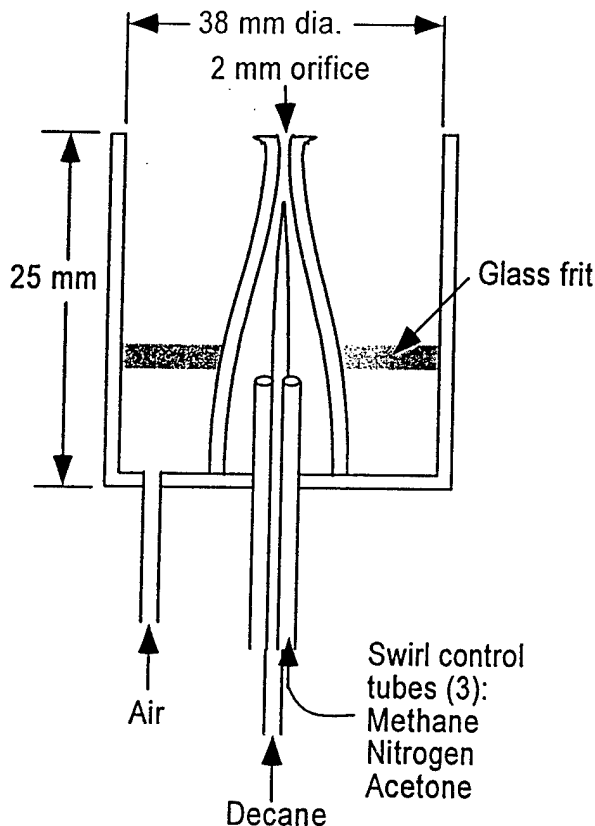

Figure 4. Quartz burner for aerodynamic droplet injection into the diffusion flame environment.

Experimental Results

Cold Flow comparison. The analytical model was also used to predict the injection of fuel droplets downward into air.¹⁴ This configuration prevailed in many of the earlier fluorescence experiments and their results provide additional data to validate the model of droplet injection. In particular, it was mentioned earlier in this paper that shear reversal was observed during previous experiments. The decane drops exhibited shear reversal approximately 36 droplet diameters downstream of the nozzle throat. This experiment utilized a jet of air to strip and accelerate the drop. The model was set up to simulate these conditions. The results of the comparison are shown in Fig. 5. The model predicts shear reversal at 37 droplet diameters, in excellent agreement with the experiment.

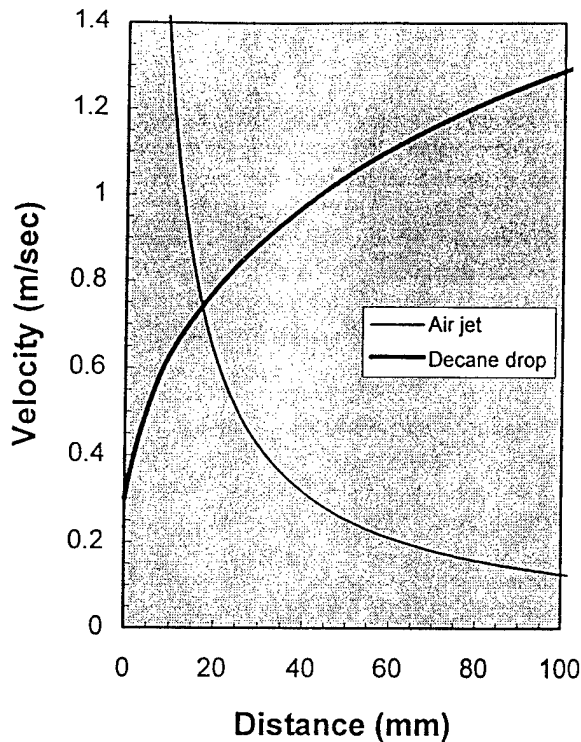

Figure 5. Analytical model prediction for decane droplet injection with an air jet downward into 1 atmosphere air. Shear reversal is predicted at 37 droplet diameters from the orifice.

Droplet Formation in Flames. Droplets were injected into the fuel flow of a methane/air diffusion flame and traveled through the flame core where they experienced a rapid temperature rise in their environment. The nozzle was positioned to eject the droplets upward because the flame behavior is optimized in that configuration. Figure 6 is a picture of the flame/injector apparatus and shows a single (burning) droplet exiting from the post flame gases after being injected through the fuel flow nozzle. Droplet slicing measurements are made in the inside (core region) of the non-premixed flame. Efforts were made to characterize the gaseous flows in an attempt to match the aerodynamic variables (such as Reynolds and Weber number) between the cold flow and combustion regimes.

Current efforts are directed to characterizing the flame characteristics and stability of the high pressure burner at elevated pressure.

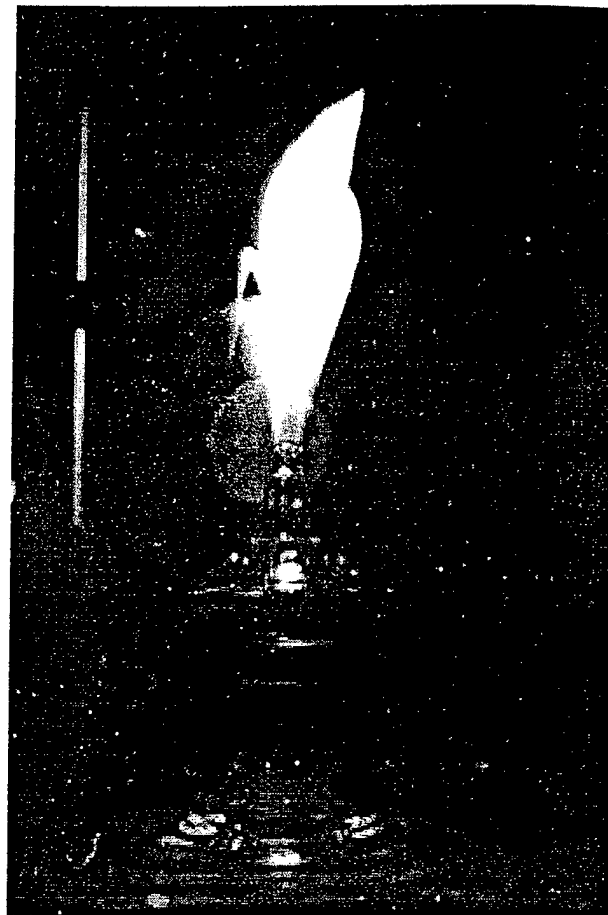

Figure 6. Diffusion flame burner with an aerodynamic droplet generator incorporated in the central fuel jet. Decane drops are injected with methane fuel into ambient air.

Summary

Droplet slicing is an effective approach to study details of thermal/mass transport in individual fuel drops. An experimental facility has been developed to investigate the internal flow of droplets using laser fluorescence techniques. As an example, droplet shear was analytically modeled and compared to experimental results. The model was used to design experimental conditions for further study in high pressure flames.

Future Work

This ongoing investigation will study the internal motion of droplets subjected to hostile combustion environments such as high temperature and pressure. Ultimately it is desired to address conditions at the critical point of the decane drops.

Acknowledgments

The authors wish to thank Jason S. Wegge for his expert technical assistance and Dr. Kyung-tae Kang for conducting experiments to characterize the high pressure burner. We gratefully acknowledge support of this work by the U. S. Army Research Office under Subcontract SC94-06 of Prime Contract DAAH04-94-G-0020 to the University of Texas at Dallas.

References

1. Amsden, A. A., O'Rourke, P. J. and Butler, T. D., Los Alamos National Laboratory, Los Alamos, New Mexico, Technical Report LA-11560-MS, May, 1989.
2. Sturges, G. J., Syed, S. A., McMasnus, K. R., Paper AIAA 84-1322, AIAA/SAE/ASME 20th Joint Propulsion Conference, Cincinnati, Ohio, June 11-13, 1984.
3. Law, C. K., Prog. Energy Combust. Sci., Vol. 8, p. 171 (1982).
4. Sanders, B. R. and Bergen, N. E., Workshop on Mass, Momentum, and Energy Exchange in Combusting Sprays: Droplet Studies, Sand89-8442, report of workshop held at Sandia National Laboratories, Livermore, CA, March 28-29, 1988.
5. Abramzon, B. and Sirignano, W. A., AIAA paper 88-0636, 1988.
6. Aggarwal, S. K., Tong, A. Y., and Sirignano, W. A., AIAA Journal, Vol. 22, p. 1448 (1984).
7. Patniak, G., Sirignano, W. A., Dwyer, H. A. and Sanders, B. R., Prog. Astronaut. Aeronaut., Vol. 105, p. 253 (1986).
8. Dwyer, H. A., Kee, R. J., Barr, P. K., Sanders, B. R., J. Fluids Eng., Vol. 105, p. 83 (1983).
9. Gogos, G., Sadhal, P. S., Ayyaswamy, P. S., Sundararajan, T., J. Fluid Mech., Vol. 171, P. 121 (1986).
10. Oliver, D. L. R. and Chung, J. N., J. Fluid Mech., Vol. 154, p. 215 (1985).
11. Ryskin, G., Int. Comm. Heat Mass Transfer, Vol. 14, p. 741 (1987).
12. Clift, R., Grace, J. R., Weber, M. E., Academic Press, 1988.
13. Winter, M. and Melton, L. A., Appl. Optics, Vol. 29, (1990).
14. Winter, M., Paper AIAA 93-0900, 31st Aerospace Sciences Meeting, Reno, NV, January 11-14, 1993.
15. Melton, L. A. and Verdieck, J. F. Combust. Sci. and Tech., Vol. 42, p. 217 (1985).
16. Steiger, M. H., Hinz, W, Sforza, P. M. and Trentacoste, N., Paper AIAA 65-49, 2nd Aerospace Sciences Meeting, New York, 1965.

APPENDIX B

Abstract for the June 1997 AFOSR Contractors Meeting

FLUORESCENT DIAGNOSTICS AND FUNDAMENTAL DROPLET PROCESSES

ARO Grant DAAH04-94-G-0020

Abstract for the June 1997 AFOSR Contractors Meeting

FLUORESCENT DIAGNOSTICS AND FUNDAMENTAL DROPLET PROCESSES

ARO Grant DAAH04-94-G-0020

Principal Investigator: Lynn A. Melton

Co-Principal Investigator: Michael Winter*

Department of Chemistry
University of Texas at Dallas
Richardson, TX 750-83-0688

Program Objectives

The purpose of the droplet slicing experiments is to investigate the shear-induced, internal motion of single fuel droplets and characterize the mass and thermal transport effects. The program utilizes 2-D images of laser-induced fluorescence from equatorial planes in the droplets to measure flow and temperature patterns. The slicing experiments have been performed in cold-flow, inert conditions and extended to a combustion environment with the further extension to a high pressure regime. In the coming year we are going to apply the same methodology to develop an understanding of strain and strain rate in the primary atomization of liquid fuel sprays.

Experiments for Strain Rate in Primary Atomization

One experimental concept relies on the principles of photoelasticity (Frocht, 1963; Jessop and Harris, 1950) with liquid crystals being used as the strain transducers in the liquid fuel. Phototlasticity is used extensively to measure the strain field of two dimensional solid objects by sensing the birefringence of orthogonally polarized light beams. Stress present in a normally isotropic medium causes the formation of a unique optic axis parallel to the direction of applied stress. Wavefronts that are propagated perpendicular to this optic axis are polarized into orthogonal waves with their planes of vibration parallel and perpendicular to the direction of stress. The stress produces an anisotropy in the index of refraction (birefringence) for the two polarizations and thus a relative retardation or phase shift between the waves. The retardation is proportional to the stress, cumulative over the optical path (depth of the medium) and thus is a line-of-sight technique.

$$r = C \cdot (P - Q) \cdot d \quad (1)$$

where r is the retardation between polarizations; C , the stress-optical coefficient of the medium; P and Q , the principal stresses in the medium, and d is the thickness of the sample. If the oppositely polarized waves are recombined to a single polarization upon exiting the sample, interference will be produced and can be quantitatively recorded as a fringe pattern similar to interferograms. The intensity of light is given by:

* United Technologies Research Center, East Hartford, CT 06108

$$I = a^2 \cdot \sin^2(2 \cdot \alpha) \cdot \sin^2 \frac{\pi \cdot r}{\lambda}$$

a^2 is the intensity of the incident polarized beam, α is the angle between the incident polarization and the axis of the principle stress and λ is the wavelength of incident light. Equation (2) implies that the direction of principle stress in the medium will produce black lines (zero intensity) where the initial polarization angle and the direction of principle stress are aligned, i.e. $\alpha=0$. Similarly, fringes are produced from the retardation r whose intensity are proportional to the stress.

Separation of the two fringe patterns, one from α and one from r , is accomplished with quarter wave plates. Experimental hardware, called a polariscope, has been developed for this technique and includes all of the appropriate optical elements for analysis of the fringe field.

Normal liquid fuels do not have birefringent properties but the class of compounds known as liquid crystals do exhibit polarization effects when subjected to changes in their environment. The major use of these compounds has been in the field of thermometry but they are also sensitive to changes in shear stress and this property has been exploited to indicate boundary layer transition on aerodynamic surfaces (Aeschliman and Croll, 1993; Reda, et al., 1993). By using them as additives to the liquid fuel, an *in situ* strain transducer is produced. Special formulations have been developed that show sensitivity to shear and are independent of temperature variations (Aeschliman and Croll, 1993). Liquid crystals are composed of long, rod-like molecules (Gray, 1962) that change their orientation upon exposure to shear stress, the reorientation produces a birefringence which can be visualized with polarization sensitive optics as used in the photoelastic experiments on solids.. Liquid crystals dispersed in a liquid fuel will provide sensors of the shear stress in their local region and the anisotropic refractive index will be monitored with imaging equipment. Encapsulated liquid crystals, typically used for thermometry and commercially available, do not allow the crystals to be in contact with the fuel molecules to sense the strain field. Unencapsulated liquid crystals are easily suspended in organic solvents and the experiment will depend on producing a liquid crystal formulation that is miscible in a typical hydrocarbon fuel such as decane. Commercial vendors (Hallcrest, Inc.) have experience with these chemicals and can provide a usable formulation. A simple experiment will start our investigation; injection of a sheet of liquid fuel into a fluid with different density and viscosity will establish a strain rate environment that can be analytically modelled and compared with the experimental data. Strain will be imposed on the sheet by the flow process and it can be illuminated with polarized laser light to observe intensity variations due to birefringement.

The demonstration of the utility of this new diagnostic technique is an important step between understanding the dynamics of individual droplets and the primary atomization processes that are responsible for the droplet formation and initial spray conditions.

References

- Aeschliman D.P. and Croll, R.H., (1993). Use of Shear-Stress-Sensitive, Temperature-Insensitive Liquid Crystals for Boundary Layer Transition Detection in Hypersonic Flows. Paper AIAA 93-3070, 24th Fluid Dynamics Conference, Orlando, FL.
- Amsden, A. A., O'Rourke, P. J. and Butler, T. D., (1989). Technical Report LA-11560-MS, Los Alamos National Laboratory, Los Alamos, New Mexico.
- Frocht, M.M., (1963). *Photoelasticity, Proceedings of the International Symposium Held at Illinois Institute of Technology, Chicago, Illinois, October 1961*. Pergamon Press, Oxford.
- Gray, G.W., (1962). *Molecular Structure and the Properties of Liquid Crystals*. Academic Press, London.
- Hallcrest, Inc., 1820 Pickwick Lane, Glenview, IL 60025 USA (<http://www.hallcrest.com>)
- Jessop, H.T. and Harris, F.C., (1950). *Photoelasticity*. Dover Publications, New York.
- Reda, D.C., Muratore, J.J. Jr. And Heineck, J.T., (1993). Experimental Investigations of the Time and Flow-Direction Responses of Shear-Stress-Sensitive Liquid Crystal Coatings. Paper AIAA 93-0181, 31st Aerospace Sciences Meeting, Reno, NV.

APPENDIX C

AIAA 94-0557

Observation of Droplet/Shock Interactions in a Supercritical Environment

Torger J. Anderson, Michael Winter and Marty Haas

UTRC, East Hartford CT



AIAA 94-0557

**Observation of Droplet/Shock
Interactions in a Supercritical
Environment**

T. J. Anderson, M. Winter and M. Haas
United Technologies Research Center
E. Hartford, CT

**32nd Aerospace Sciences
Meeting & Exhibit**
January 10-13, 1994 / Reno, NV

Observation of a Droplet/Shock Interaction in a Supercritical Environment

Torger J. Anderson, Michael Winter and Marty Haas
United Technologies Research Center
East Hartford, Connecticut 06108

Abstract

This paper describes the results of experiments to observe and quantify droplet break-up and evaporation occurring after the passage of a weak shock wave to simulate processes which occur and might be responsible for instabilities in liquid fueled rocket engines. Results from experiments simulating subcritical conditions are described and initial results of experiments studying shock/droplet interactions in a supercritical environment are presented.

Introduction

The enhancement of droplet break-up and vaporization by acoustic pulses leading to combustion instabilities in liquid-fueled rocket engines may be affected by thermodynamic conditions within the combustor. Models have been developed¹⁻² and experiments conducted³⁻⁴ to quantify the acoustic field enhancement to droplet vaporization which may lead to these instabilities. While the initial experiments were limited to low pressures and temperatures, actual conditions within the combustor are quite different from this. These differences may lead to significantly different modes and rates of droplet breakup than expected and, hence, unexpected effects on combustion stability. In particular, the fact that the combustor temperatures and pressures are typically well above the critical levels for the injected fluids could significantly alter the mode of droplet breakup or dispersion in the surrounding fluid. Since surface tension becomes negligible in a

supercritical fluid, droplets will not necessarily be perturbed in a manner in which surface tension plays a significant role. Understanding of the critical transition of subcritical droplets injected into a supercritical environment is necessary for an understanding of the mixing processes which occur in liquid-fueled rocket engines.

Background

In a typical rocket combustor environment cryogenic oxidizer sprays are injected into hot fluids at supercritical temperature and pressure. Heat transfer to the droplet elevates the temperature to supercritical conditions, but this is a transient process which, in the absence of a strong convective field, occurs along a radially inward path as heat is absorbed. The effect of an acoustic pulse and the associated velocity field in enhancing heat transfer and breaking up a droplet undergoing such a transition is not fully understood. While models of this process have been developed and scaled experiments performed to investigate this behavior⁵, it has not been experimentally observed for the case of individual droplets under supercritical conditions.

Initial experiments were done to evaluate evaporation rates on droplets at room temperature and pressure conditions. Even in these easily-attained conditions, measurements have been limited because of the inability to resolve such small length and short time scales using existing diagnostic techniques. However,

P_r	Droplet Fluid	Droplet Dia. (μm)	We	Re	We/Re
1.1	Methanol	70	1.7	3.3	.51
1.2	Methanol	70	6.4	6.4	1.00
1.2	Water	70	2.4	3.8	.62

Table II. Weber and Reynolds number comparisons for the three test conditions using weak shock waves.

Experiment

Continuing in the effort to study liquid stability mechanisms, a high pressure pulse tube was built under United Technologies corporate sponsorship to provide a supercritical environment in which the droplet break-up process may be observed. This facility, diagrammed in Fig. 2, is capable of pressures up to 68 atm in a windowed test section designed to incorporate optical and laser-based diagnostic techniques. A driver section separated by a dual burst disk system can contain pressures up to 156 atm to repeatably generate shock waves with pressure rises up to 50% so that prescribed conditions can be studied. (For these experiments, waves with pressure ratios on the order of 1.1 have been repeatably produced.) The entire assembly was mounted on a steel I-beam frame and the driver section, made of 3 in. schedule 80 stainless steel pipe, is mounted on a track system so that the double burst disk assemblies can be easily replaced for fast turn-around. A hydraulic driver is used to secure the driver and burst disk assembly when the system is pressurized.

The test section is an integral part of the driven section and has a 51 mm square cross section and cut from a stainless steel forging. Additional holes were cut to attach a high pressure container for a droplet generator or coaxial injector and to provide two 48 mm and one 19 mm viewing ports for optical access. A purge system is also built into the test

section to keep the windows clean, but it was not required in this test program.

The remainder of the driven section of the pulse tube is composed of a number of spool pieces, both to simplify fabrication and to allow the flexibility of using a variety of driver and buffer gases with different molecular weights and specific heat ratios. These sections are constructed of 51 in. square aluminum extruded tube encased in 4 in. schedule 80 stainless steel pipe with a Cerro-bend filler. This incompressible lead-based material could be melted with hot water and was poured between the outer pipe and inner square tubing to prevent distortion of the square cross section by transferring pressure to the pipe. The downstream section contains an additional window at the tube end to allow 90 deg. optical access into the test section. An optional baffle plate can be installed just upstream of this window to reduce the impulse load which could be generated by an incident shock wave.

A cryogenic droplet generator was developed to produce a stream of liquid oxygen (LOx) droplets of several hundred micron diameters in the high pressure pulse tube. This device, shown schematically in Fig. 3, is a heat exchanger made from copper tubing and using liquid N_2 to condense O_2 gas. The liquid N_2 is allowed to flow through the double-pass outer section of the generator until the device has reached thermal equilibrium. High pressure gaseous O_2 is then flowed into

Initial Pressure (atm)	Wave Strength			Reynolds no. (Re)	Weber no. (We)	Ohnesorge no. (Oh)
	ΔP (atm)	Pressure ratio	Mach no.			
40.8	4.6	1.05	1.021	11,300	501	2.6×10^{-3}
51.0	4.6	1.04	1.017	11,700	442	2.6×10^{-3}
51.0	8.8	1.08	1.031	21,300	1501	2.6×10^{-3}
57.8	4.6	1.04	1.015	11,400	370	2.6×10^{-3}

Table III. Test conditions in the high pressure pulse tube using O₂ droplets.

for runs with initial pressures of 51.0 atm and 57.8 atm, both condition above the critical pressure (the critical temperature for O₂ is below room temperature). Two sets were acquired at an initial pressure of 51.0 atm; one with a wave strength consistent with the low pressure conditions and one with a stronger pressure pulse. The test conditions are shown in Table III.

Results

Images were acquired for liquid oxygen (LOX) droplets, both above and below the critical pressure of O₂. The chosen conditions resulted in Reynolds numbers in the range of 11,000-21,000, Weber numbers of 400-1500 and an Ohnesorge number of 2.6×10^{-3} . The sample images shown in Figs. 4-5 demonstrate that the droplet breakup process appears to be quite similar for droplets above and below the critical pressure, given nearly constant acoustic wave strength. Since one would expect the process to change significantly with a change in the droplet surface tension (which should occur as the surface rises above the critical temperature) these results suggest that the breakup process occurs on time scales much shorter than heat transfer to the droplet surface, hence, the droplet continues to act as a liquid.

Further quantitative measurements are required to

determine the apparently more subtle differences between the processes occurring at sub- and supercritical conditions.

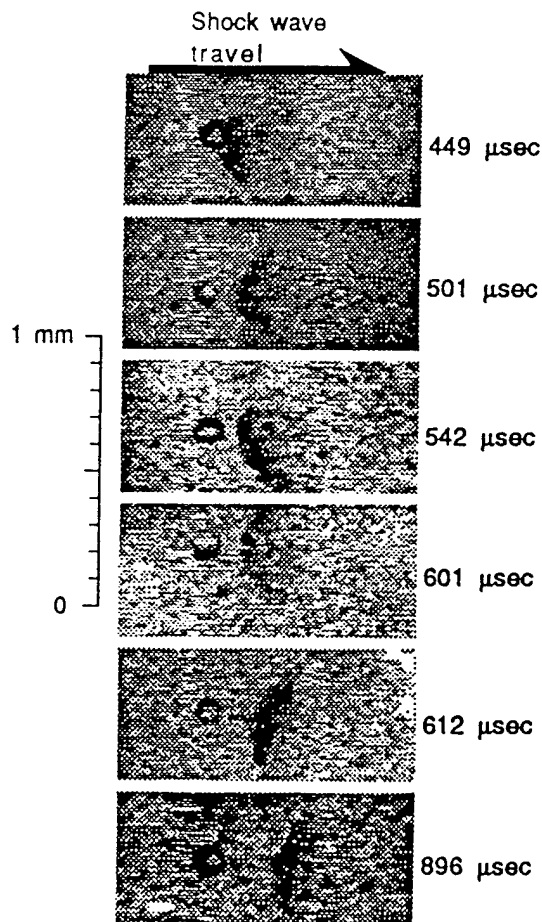

Fig. 4. Double exposure of LOx droplets before and after shock wave passage in supercritical conditions. Pressure before and after wave passage is 51/55 atm and time delay after passage is shown.

Vaporization Rates," presented at the JANNAF Combustion Meeting, October 19-23, 1992 at NASA Langley, Hampton, VA.

4. T. W. Eastes and G. S. Samuelsen, "Secondary Atomization by High Amplitude Pressure Waves," AIAA paper number 92-3120 presented at the 28th Joint Propulsion Conference, July 6-8, 1992, Nashville, TN.
5. P.-K. Wu, L.-P. Hsiang and G. M. Faeth, "Aerodynamic Effects on Primary and Secondary Spray Breakup," presented at the First International Symposium on Liquid Rocket Combustion Instability, January, 1993, Pennsylvania State University, University Park, PA.
6. Tzeng, H.-M., K. F. Wall, M. B. Long and R. K. Chang, "Evaporation and Condensation Rates of Liquid Droplets Deduced from Structure Resonances in the Fluorescence Spectra," Optics Letters, Vol. 9, pp. 273275, Jul 1984.
7. Quian, S.-X., J. B. Snow, H.-M. Tzeng and R. K. Chang, "Lasing Droplets: Highlighting the Liquid-Air Interface by Laser Emission," Science, Vol. 231, pp. 486-488, Jan 1986.

APPENDIX D

AIAA 95-0140

Oxygen Concentration Measurements in a High Pressure Environment Using Raman Imaging

Torger J. Anderson and Michael Winter

UTRC, East Hartford CT

Roger D. Woodward

Phillips Laboratory, Edwards AFB, CA



AIAA 95-0140

**Oxygen Concentration
Measurements in a High Pressure
Environment Using Raman Imaging**

Torger J. Anderson
United Technologies Research Center
East Hartford, Connecticut 06108

Roger D. Woodward
Phillips Laboratory
Edwards AFB, California 93524

Michael Winter
United Technologies Research Center
East Hartford, Connecticut 06108

**33rd Aerospace Sciences
Meeting and Exhibit
January 9-12, 1995 / Reno, NV**

Oxygen Concentration Measurements in a High Pressure Environment Using Raman Imaging

by

Torger J. Anderson
United Technologies Research Center
East Hartford, Connecticut 06108

Roger D. Woodward
Phillips Laboratory
Edwards AFB, California 93524

Michael Winter
United Technologies Research Center
East Hartford, Connecticut 06108

Abstract

This paper describes the development of Raman imaging as a diagnostic for concentration measurements in high pressure and supercritical environments. The objective is to study liquid oxygen droplet breakup under supercritical conditions simulating a liquid-fueled rocket engine combustor. While future measurements will involve droplet interaction with a strong acoustic field, the initial measurements described here show the applicability of the Raman diagnostic to the measurement environment.

Introduction

The enhancement of droplet breakup and vaporization by acoustic pulses leading to combustion instabilities in liquid-fueled rocket engines may be affected by thermodynamic conditions within the combustor. Models have been developed¹⁻² and experiments conducted³⁻⁴ to quantify the acoustic field enhancement to droplet vaporization which may lead to these combustion instabilities. While the initial experiments were limited to low pressures and temperatures, actual conditions within the combustor are quite different from this. These

This paper is work funded by the U.S. Government and is not subject to copyright protection in the United States.

differences may lead to significantly different modes and rates of droplet breakup than expected and, therefore, have not been modeled in previous studies. In particular, the fact that the combustor temperatures and pressures are typically well above the critical levels for the injected fluids could significantly alter the mode of droplet breakup or dispersion in the surrounding fluid.⁵ Since surface tension becomes negligible in a supercritical fluid, droplets (or "masslets") will not necessarily be perturbed in the same manner typically observed in low pressure laboratory environments (where surface tension plays a significant role). Understanding the critical transition of subcritical droplets injected into a supercritical environment is necessary for understanding of the mixing processes which occur in liquid-fueled rocket engines.

In a typical rocket combustor environment cryogenic oxidizer sprays are injected into hot fluids at supercritical temperatures and pressures. Heat transfer to a droplet elevates the temperature to supercritical conditions, but this is a transient process which, in the absence of a strong convective field, occurs along a radially inward path as

heat is absorbed. The effect of an acoustic pulse and the associated velocity field in enhancing heat transfer and breaking up a droplet undergoing such a transition is not fully understood. Models of this process have been developed and scaled experiments have been performed to investigate this behavior.⁶

A pulse tube facility has been built to study the breakup of supercritical droplets under realistic pressure and acoustic conditions.⁷ It has been used to observe this process with liquid O₂ (LOX) droplets using schlieren photography, but only limited qualitative data has been acquired. A diagnostic is necessary which is capable of providing temporally-resolved O₂ concentration measurements in the region surrounding a droplet as it is interacting with an acoustic pulse. One possible technique is Raman imaging. This technique has been developed for this application and evaluated by UTRC and the Air Force Phillips Laboratory under an Air Force program.

Discussion

Raman scattering measurements have been applied to a wide range of processes ever since the laser became a practical laboratory tool.⁸ With this technique, a signal is generated which is spectrally shifted from an incident laser beam providing a means of separating it from scattered laser light. The spectral shape and intensity of the signal identifies temperature and species concentrations of complex molecules (diatoms or larger) in the measurement volume. The limitation of the use of Raman scattering has been the relative weakness of the signal in comparison to strong background interferences in most combustion applications.

Despite these limitations, the technique has potential in the type of

experiments described above. The high molecular number density at O₂ supercritical pressures and room temperature is sufficient to generate a measurable Raman signal from a typical pulsed frequency-doubled Nd:YAG laser beam (a green beam at 532 nm). Simple spectral filtering requirements and the lack of combustion make it possible to eliminate background interferences to make such measurements. This paper describes the initial experiments and indicates the potential capabilities of Raman imaging as a measurement tool for LOX droplet measurements.

Experiment

Raman measurements were made in a cylindrical pressure bomb (102 mm dia. x 305 mm) with optical access through four 25 mm dia. windows allowing the laser beam to be projected through a stream of LOX droplets and out of the bomb with 90 deg. optical access for imaging of the Raman signal. The bomb was capable of withstanding pressures well in excess of the O₂ critical condition (T=155K, P=49.8 atm) and tests were run with pressures as high as 68 atm. The temperature was nominally below room temperature; injection of the LOX and conduction from the attached droplet generator suppressing the temperature below that of the surrounding ambient. Gas temperature in the bomb was continually monitored and registered between 250 and 273 K during the measurements.

Droplets were injected with a cryogenic droplet generator developed and fabricated at the Phillips Laboratory. A schematic drawing is shown in figure 1 and the injector is discussed in more detail in Ref. 9. The device uses liquid N₂ (LN₂) to condense a small amount of high pressure O₂ flowing from a gas cylinder through a 7 μ m filter and into a chamber

above the bomb. Pressure from the gaseous O_2 supply drives the LOX through a $127\ \mu\text{m}$ orifice generating a LOX stream in the bomb. A cylindrical piezo-electric crystal is driven with a pulse generator and high voltage amplifier to excite a Rayleigh instability in the LOX stream, producing a fairly regular stream of droplets in the size regime of 100 to 300 μm . Size could be altered by changing the gaseous O_2 flow rate and then adjusting the excitation frequency and amplitude to produce the Rayleigh instability. Repeatable mono-dispersed LOX droplet streams could be generated in helium (He) at pressures greater than 68 atm with this system.

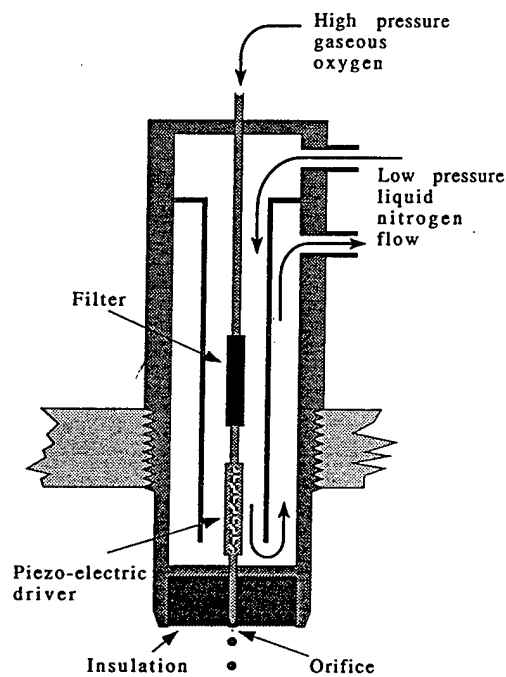

Fig. 1. LOX droplet injector schematic.

At the conditions described, the pressure is about 1.4 times the critical pressure of pure O_2 and the temperature in the vicinity of the droplets is at least 1.6 times the critical value for the pure substance. At such conditions, it is unclear if the critical state has been reached for O_2 in He since this condition is dependent on both fluids. Liquid/vapor phase equilibrium and enhanced solubility at high

pressures must be accounted for in determining the actual critical state for the mixture.⁵ Observations made in other systems (e.g., hydrocarbon droplets in air¹⁰) indicate that supercritical vaporization may not occur until the pressure is at least twice the critical value of the pure phase. Despite these concerns, the actual state of the O_2 fluid should have no effect on the applicability of Raman imaging and testing under these conditions was completed to demonstrate the capability.

Typical operation of the experiment began with pressurization of the bomb and generation of a LOX stream. The stream would be viewed by back-lighting with a strobe through the fourth window opposite the camera viewing window.⁹ The strobe and camera were synchronized to the laser pulse. The O_2 flow rate and the excitation frequency and amplitude were adjusted to produce a steady stream of droplets of the desired size.

Tests were made with several buffer gases in the bomb. He proved to be the best choice from several points of view. It is inert, reducing the hazards associated with the use of LOX. It is supercritical at test pressures and temperatures avoiding the potential for condensation at the cold upper flange of the bomb. He is not Raman active so it does not introduce background noise to the O_2 Raman signal. Finally, in terms of molecular weight and thermal properties, it is a reasonable H_2 simulant; a desirable choice for rocket combustor simulations.

The Raman signal was produced with a pulsed SpectraPhysics DCR1a Nd:YAG laser capable of generating 10 nsec 300 mJ frequency-doubled (532 nm) pulses at 10 Hz. The beam was transformed into an 8 mm wide sheet by focusing it with a 250 mm cylindrical lens as it was projected into the test section. Single shot images were acquired with a gated Stanford

Research intensified CCD camera and a 75 mm f/1.3 lens. The camera was located 200 mm from the droplet stream and the aperture was effectively limited by the bomb window diameter to f/4.0. The intensifier was gated to time the laser pulse during a 50 μ sec camera exposure, but longer gates could have been used since background interferences were very small.

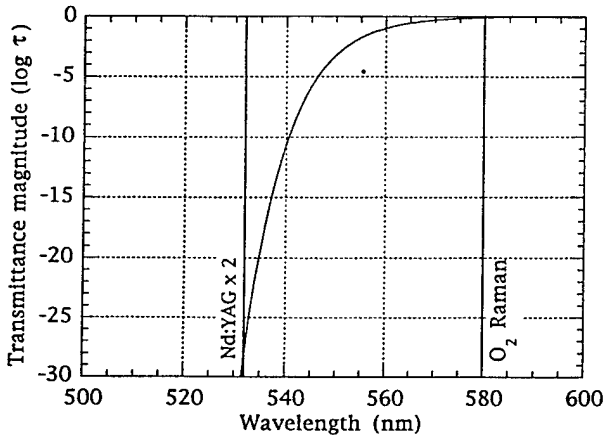

Fig. 2. The O_2 Raman signal is separated from the 532 nm laser beam with 3 mm of OG570 glass. This attenuates the laser beam by over 25 orders of magnitude while reducing the Raman signal by only 2%.

Separation of the Raman signal from the laser was accomplished with 3 mm of Schott OG570 filter glass. As can be seen from figure 2, this glass alone provides over 25 orders of magnitude of discrimination between the signal and laser while attenuating the signal intensity by no more than 2% (excluding surface losses). Care was taken to minimize background contributions from weak window fluorescence and emissions occurring due to laser beam reflections from bomb internal walls. A background signal would eventually build up as LOX droplets evaporated and O_2 became a significant constituent of the buffer gas. To reduce this effect, a small vent was installed in the bottom of the bomb below the droplet stream and gas was vented while He buffer gas was introduced to maintain constant bomb pressure and buffer gas consistency. A

small funnel was located above the vent to capture any un-evaporated LOX and to increase the O_2 concentration of the vented gas. This allowed operation of the system at high pressure for sufficient time to adjust the droplet stream and acquire data.

Results

Difficulties were continuously encountered with optical breakdown of O_2 molecules in the droplets caused by focusing of the high power laser beam into the interior. The generation of this plasma produced a bright broadband flash which would overwhelm the Raman signal and could potentially damage the intensified camera. A considerable effort was made to overcome this problem by compromising laser intensity for Raman signal strength in various ways. Initially, the laser sheet was expanded in the sheet plane to further separate the planar and transverse focuses, reducing the energy concentration within the droplets. This was insufficient to eliminate the problem, however. The laser sheet focus was moved axially along the beam path to reduce the intensity at the droplet stream (sheet thickness at the droplet stream became approximately 500 μ m). This configuration was necessary to acquire data through the remainder of the testing. The most successful method of reducing breakdown was the introduction of a loop in the laser beam path (figure 3) which spread the 10 nsec. pulse temporally, lowering the peak power and increasing the pulse energy necessary to reach the breakdown threshold.

Figure 4 shows the effect of the beam splitting loops on the pulse shape and length. The peak intensity is reduced by more than 60% (excluding mirror losses) and the pulse has been expanded by over 100%. The pulse

energy was reduced with this technique to 250 mJ, but the breakdown threshold was increased from about 150 mJ/pulse without the loop to about 210 mJ/pulse after its installation.

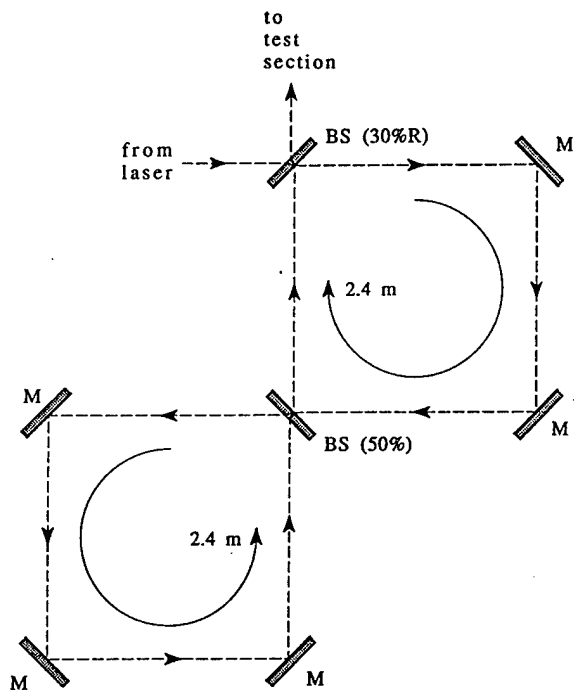

Fig. 3. Beam splitting optical circuit used to lower the laser pulse peak power.

Predictions of Raman signal intensity using ref. 8 and 11 were based on the optical geometry, conditions in the bomb, pulse energy and camera sensitivity. They indicated that measurements of O_2 could be made at 68 atm (supercritical pressure for pure O_2) with a sensitivity of about 3.4 kg mol./m^3 (1% mole fraction). To provide a means of quantifying O_2 concentration and to verify the sensitivity analysis, calibration images were acquired using room temperature O_2 at several pressures. The measured sensitivity of the technique was limited by the noise level of the camera to approximately 10 mol./m^3 (4% mole fraction at 68 atm). The difference from the calculated value rests primarily in camera- and optics-

related losses and background noise not considered in the analysis.

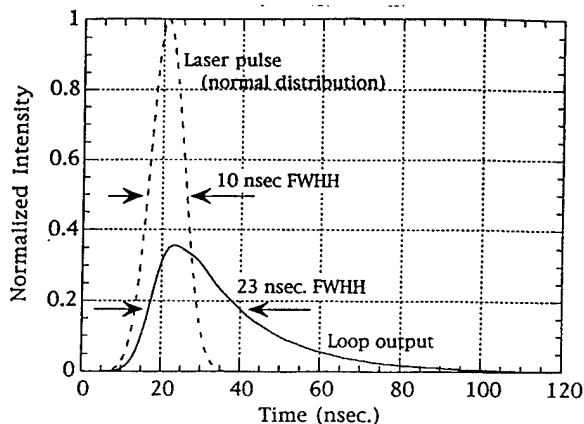

Fig. 4. Analytical comparison of a 10 nsec laser pulse with the output of the beam splitting loop in figure 3.

Figure 5 is a sample backlit image of the droplet stream at 68 atm. Figure 6 contains Raman images of several comparable droplet streams. The wake of supercritical O_2 can be clearly seen in the Raman images and, despite the low signal strength, concentration contours can be drawn as shown in figure 7. The raggedness of the 340 kg/m^3 contour indicates that the system has reached the minimum level of sensitivity (signal/noise). These images do not show a clearly defined orientation of the wake which one would expect as a result of the downward velocity of the droplet stream. Several factors may account for this. The wake region contains accumulated O_2 from many droplets in the stream and convection is occurring due to the continual purging of the buffer gas. Also the "evaporation" (to supercritical fluid) is occurring at a very high rate and may generate a flow field much stronger than that produced by the droplet stream.

An unexpected result of these tests was the discovery of a strong signal generated at a low pulse energy, when the laser was run un-Q switched. Under this condition, the laser pulse was approximately 100 μsec in length

with an energy of 0.5 mJ; insufficient to generate a detectable spontaneous Raman signal. The signal was not spectrally characterized except through visual observation. Droplets appeared to be distinctly orange - in the spectral region of the O₂ Raman signal. A likely possibility is that a morphology dependent resonance (MDR)¹⁰ based on a stimulated Raman signal¹² constrained to the interior of the LOX droplets. The existence of such a signal suggests that there is a clearly defined liquid/vapor interface and that, in fact, the critical condition for O₂ in He has not yet been reached. Alternatively, the refractive index gradient of a transcritical fluid is great enough to minimize losses at the interface and produce the MDR's (consistent with the analysis of S. Hill¹⁴).

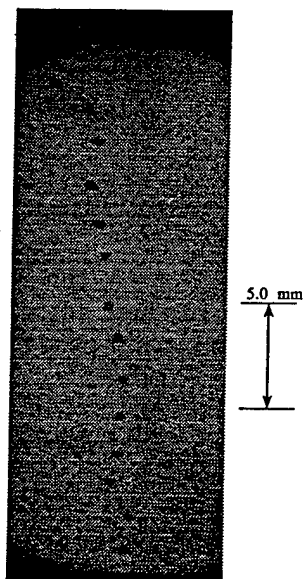

Fig. 5. LOX droplet stream in a high pressure He environment (68 atm, room temp.). Droplet size is approximately 300 μ m. The stream is being deflected by convection currents and droplet/wake interactions.

Conclusions

The measurements acquired thus far indicate that spontaneous Raman imaging has potential as a diagnostic in the supercritical mixing exper-

iments to be conducted. While the signal has been less than desired for accurate measurements, some paths to improving the signal strength are apparent. Lower f/# optical axis is desirable and will be available as the experiment moves from the bomb to the pulse tube. The breakdown limitation to laser pulse power was found to be dependent on laser pulse length. However, it appears that significant increases over the 10 nsec. pulse length are necessary to have much of an effect.

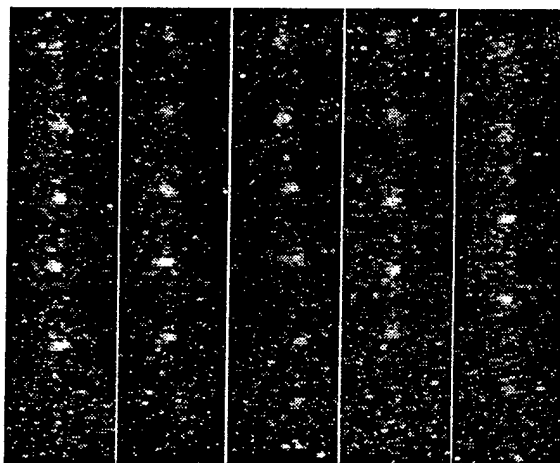

Fig. 6. Five Raman images of LOX droplet stream at 68 atm. and room temp. (supercritical condition for pure O₂) The image is the central portion of the stream illuminated by the laser sheet.

The observation of what is believed to be stimulated Raman MDR's deserves further investigation. An understanding of this phenomenon through spectral analysis could provide information on the process that is occurring at the critical interface of liquid structures in a supercritical environment.

Future Work

A continuation of this program will address several important areas. The existence of the MDR's may provide important information about the fluid

within the LOX droplets under supercritical and subcritical conditions. However, it will be necessary to examine these signals spectrally. A high resolution Raman spectrometer will be used to make these measurements in the bomb.

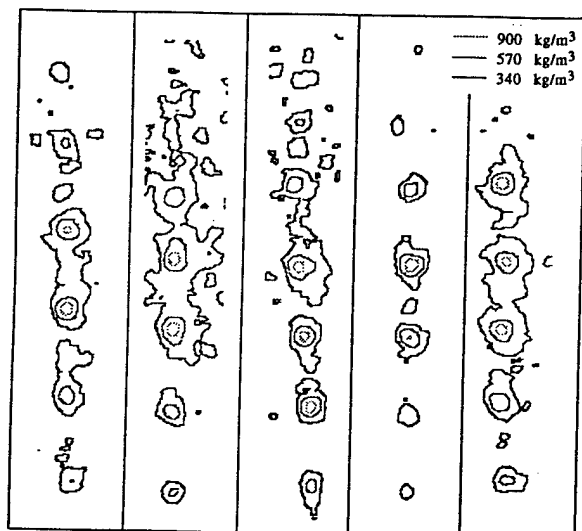

Fig. 7. O₂ concentration contours derived from intensities in the images of figure 6 after correcting for background and response. Three concentration levels are shown with different contours.

Accurate Raman concentration measurements will require more laser pulse energy, currently restricted by LOX breakdown in the droplets. The use of an ultraviolet laser (either the fourth harmonic of the Nd:YAG or an excimer laser) was considered for this application since the Raman signal is enhanced due to the shorter wavelength (λ) by a factor of λ^{-4} . (In the case of the Nd:YAG laser, the signal would be improved by a factor of 16 at fixed laser intensity.) However, the enhancement of the signal strength is more than overcome by losses in filtering to separate the laser scattering at those wavelengths and by the increased background due to a variety of laser-induced fluorescence.

The ability to raise the breakdown threshold by lowering the peak laser power suggests the use of a long pulse

laser to continue the program. At UTRC, a high power dye laser (Candela model UV-8000) capable of generating 45 J in a 6 μ sec pulse will be used in the continuation of this work. Although it is operated at a different wavelength, spectral filtering can be accomplished in a similar manner using a different filter glass.

A variable pulse Nd:YAG laser (800 mJ/pulse at 532 nm) with the ability to extend the pulse length to more than 200 nsec will be used in similar efforts at the Air Force Phillips Lab.

Acknowledgments

This work was completed under contract number DAAH04-94-G-0020 from the U.S. Army Research Office and the Air Force Phillips Laboratory. The authors would like to acknowledge the guidance provided by many useful discussions with J. Levine and D. G. Talley of the Air Force Phillips Laboratory. The authors would also like to acknowledge the contributions of A. C. Eckbreth who suggested the technique for extending the laser pulse length.

References

1. Tong, A. Y. and W. A. Sirignano, "Oscillatory Vaporization of Fuel Droplets in an Unstable Combustor," *AIAA Journal of Propulsion*, Vol. 5, pp. 257-261, May-June 1989.
2. Tong, A. Y. and W. A. Sirignano, "Multicomponent Transient Droplet Vaporization: Integral Equation Formulation and Approximate Solution," *Numerical Heat Transfer*, Vol. 10, pp. 253-278, 1986.
3. Anderson, T. J. and M. Winter, "Measurements of the Effect of Acoustic Disturbances on Droplet Vaporization Rates," presented at the JANNAF Combustion Meeting, October 19-23, 1992 at NASA Langley, Hampton, VA.

4. Eastes, T. W. and G. S. Samuelsen, "Secondary Atomization by High Amplitude Pressure Waves," AIAA paper number 92-3120 presented at the 28th Joint Propulsion Conference, July 6-8, 1992, Nashville, TN.
5. Yang, Y., N. N. Lin and J.-S. Shuen, "Vaporization of Liquid Oxygen (LOX) Droplets in Supercritical Hydrogen Environments," *Combustion Science and Technology*, Vol. 97, pp. 247-270, 1994.
6. Wu, P.-K., L.-P. Hsiang and G. M. Faeth, "Aerodynamic Effects on Primary and Secondary Spray Breakup," presented at the First International Symposium on Liquid Rocket Combustion Instability, January, 1993, Pennsylvania State University, University Park, PA.
7. Anderson, T. J., M. Winter and M. Haas, "Observation of Droplet/Shock Interactions in a Supercritical Environment," presented at the AIAA 32nd Aerospace Sciences Meeting, January 10-13, 1994 at Reno, NV.
8. Gardiner, D. J. and P. R. Graves (editors), Practical Raman Spectroscopy, Springer-Verlag, New York, 1989.
9. Woodward, R. D., D. G. Talley, T. J. Anderson and M. Winter, "Shadowgraphy of Transcritical Cryogenic Fluids," presented at the 6th Annual Symposium of the Pennsylvania State University Propulsion Engineering Research Center, NASA LeRC, Cleveland, OH, September, 1994.
10. Faeth, G. M., D. P. Dominicus, J. F. Tulpinsky and D. R. Olson, "Supercritical Bipropellant Droplet Combustion," *Twelfth Symposium (International) on Combustion*, The Combustion Institute, pp. 9-18, 1969.
11. Inaba, H. and T. Kobayasi, "Laser-Raman Radar - Laser-Raman Scattering Methods for Remote Detection and Analysis of Atmospheric Pollution," *Optoelectronics*, Vol. 4, pp. 101-123, 1972.
12. Tzeng, H.-M., K. F. Wall, M. B. Long and R. K. Chang, "Laser Droplets: Highlighting the Liquid-Air Interface by Laser Emission," *Science*, Vol. 231, pp. 486-488, Jan. 1986.
13. Walmsley, I. A., "The Stimulated Raman Effect, An Introduction," The Institute of Optics, University of Rochester, Rochester, NY, 1989.
14. Chowdhury, D. Q., S. C. Hill and P. W. Barber, "Morphology-dependent Resonances in Radially Inhomogeneous Spheres," *Journal of the Optical Society of America*, Vol. 8, pp. 1702-1705, 1991.