

# REPORT DOCUMENTATION PAGE

*Form Approved*  
OMB No. 0704-0188

Public reporting burden for this collection of information is estimated to average 1 hour per response, including the time for reviewing instructions, searching existing data sources, gathering and maintaining the data needed, and completing and reviewing the collection of information. Send comments regarding this burden estimate or any other aspect of this collection of information, including suggestions for reducing this burden to Washington Headquarters Services, Directorate for Information Operations and Reports, 1215 Jefferson Davis Highway, Suite 1204, Arlington, VA 22202-4302, and to the Office of Management and Budget, Paperwork Reduction Project (0704-0188), Washington, DC 20503

1. AGENCY USE ONLY (Leave Blank)	2. REPORT DATE 11/30/97	3. REPORT TYPE AND DATES COVERED Final Report 7/94-9/97	
4. TITLE AND SUBTITLE Precision Imaging and Measurements for Structural Acoustics		5. FUNDING NUMBERS  N00014-94-1-0947 432p006....16	
6. AUTHOR(S) Yves H. Berthelot		8. PERFORMING ORGANIZATION REPORT NUMBER	
7. PERFORMING ORGANIZATION NAME(S) AND ADDRESS(ES) Georgia Institute of Technology Office of Contract Administration - 0420 Atlanta, GA 30332		9. SPONSORING/MONITORING AGENCY NAME(S) AND ADDRESS(ES) Office of Naval Research 800 North Quincy Street Arlington, VA 22217-5660	
11. SUPPLEMENTARY NOTES COR:			
12a. DISTRIBUTION/AVAILABILITY STATEMENT Unlimited		12b. DISTRIBUTION CODE	
13. ABSTRACT (Maximum 200 words) A fiberoptic laser Doppler interferometric system has been designed, built, and tested for measurements (0.5 - 3kHz) of surface vibrations in structural acoustics. The two complex elastic moduli of a voided polymer have been measured as a function of frequency. The measurement errors associated with this new technique are discussed.			
14. SUBJECT TERMS  Laser interferometry, viscoelastic materials, bulk and shear moduli		15. NUMBER OF PAGES	
17. SECURITY CLASSIFICATION OF REPORT Unclassified		16. PRICE CODE	
18. SECURITY CLASSIFICATION OF THIS PAGE Unclassified		19. SECURITY CLASSIFICATION OF ABSTRACT Unclassified	
20. LIMITATION OF ABSTRACT Unlimited		21. LIMITATION OF ABSTRACT Unlimited	

**DTIC QUALITY INSPECTED**

**AASERT GRANT 02-103-025-94-033**

**FINAL REPORT**

**ONR Grant Information**

Grant Title:	Precision imaging and Measurements for Structural acoustics
Performing Organization:	Georgia Institute of Technology
Principal Investigator:	Yves H. Berthelot yves.berthelot@me.gatech.edu
Grant number:	N00014-94-1-0947
R & T number:	432p006...16
Parent Grant Number:	N00014-97-1-0185
Parent PR Number:	97PR03144-01
ONR Scientific Officer:	Geoffrey L. Main, code 334

19971208 074

## Overview of the research objectives

The objective of this research effort was to develop the expertise and the experimental research capabilities for precision laser Doppler measurements of surface vibrations relevant in structural acoustics. Over the three years covered by the AASERT grant (07/94 to 08/97), the main research effort concentrated on building a laser system that could be used to determine the two complex elastic moduli (bulk and shear) of a voided polymer within known and acceptable error bounds.

## Relevance to the Navy

Effective ship hull treatment depends in part on a good understanding of the acoustic properties of the viscoelastic layer attached to the hull. Measuring the shear and bulk dynamic moduli of a viscoelastic sample is therefore critical to predict correctly acoustic performance. Two of the most common experimental techniques used to measure dynamic moduli are the resonant technique (Madigosky and Lee) and the DMTA (Dynamic mechanical testing apparatus), both of which are very useful but have some intrinsic limitations. The proposed laser-based experimental/numerical technique is an alternative, noncontact, method capable of measuring *simultaneously both shear and bulk moduli*, an important advantage since manufacturing variabilities and hysteretic material response are common sources of errors.

## Technical Approach

In the first phase of the research program, a set of five independent laser Doppler interferometers was built, calibrated, and tested for measurements of structural vibrations in the 0.3 - 5 kHz range. The design relies on optical fibers so that the laser probe heads can be placed relatively far from the optical bench. The optical probe heads were designed to be very compact and capable of measuring either out-of-plane or in-plane surface motion. (Two photographs of the experimental setups are available on the web site <http://www.me.gatech.edu/yves.berthelot/bothphotos.html>)

The second phase of the research was to use the system to measure the frequency-dependent bulk and shear moduli of some voided polymers. A sample of arbitrary shape (typically, a rectangular block of 1"x2"x3") is excited harmonically at its base (by a shaker or a piezoelectric stack). The surface dynamics of the sample is non-invasively measured at several points (in-plane and out-of plane surface velocities - amplitude and phase) by a set of four independent fiberoptic laser Doppler interferometers and referenced (amplitude and phase) to its base motion. The material parameters are determined from a least-square fit between the experimental data and numerical predictions obtained from a finite element code in which the frequency-dependent elastic moduli are the adjustable parameters.

## Major Results

### 1) Hardware

#### 2.1: Five probe laser system

A five probe fiberoptic interferometer system has been designed and calibrated for laboratory measurements of surface vibrations at ambient conditions has been built and calibrated. (See Willis et al. JASA, 102 (5), Nov 1997). See also Figure 1. Typical performances and characteristics are shown in Table 1.

	<i>In-plane</i>	<i>Out-of-plane</i>
Noise floor ( <i>w/o ave.</i> )	65 $\mu\text{m/s}$ - rms	35 $\mu\text{m/s}$ - rms
Noise floor ( <i>w/ 64 ave</i> )	5 $\mu\text{m/s}$ - rms	3.5 $\mu\text{m/s}$ - rms
Maximum velocity	35 mm/s - peak	17 mm/s - peak
Maximum displacement	18 $\mu\text{m}$ - peak	125 $\mu\text{m}$ - peak
Sensitivity	23.7 ( $\mu\text{m/s}$ ) / mv	11.7 ( $\mu\text{m/s}$ ) / mv
Bandwidth	DC - 10 kHz	DC - 10 kHz

Table 1: Typical performance and characteristics of the interferometers.

#### 1.2: Two probe scanning system

A two probe scanning system is being completed for measurements inside a small pressure/temperature chamber. (0-500 psi , 6-40 C). Direct measurements in a pressure - temperature chamber will alleviate some of the problems currently encountered with the use of time-temperature superposition principle and associated shifts.

#### 1.3: Single probe system

A separate single probe system (either in-plane or out-of-plane) for independent calibrations and testing. This system can be also used in the Mhz range for ultrasonics.

### 2) Software

#### 2-1: Automated data acquisition (Labview) and Processing (Matlab)

The 5 laser probe system has been automated for data acquisition and processing. The system is capable of acquiring 7 signals (from two digital oscilloscopes), including 2 reference signals, 64 times at a given frequency. Each signal is analyzed with a DFT to measure the complex amplitude at the frequency of interest relative to the complex amplitude of the base excitation.

#### 2-2: Finite element code (Fortran)

A finite element code is used to model the dynamic behavior of the sample. The code uses 825 nodes, and 36 quadratic elements. The boundary conditions are such that the all faces

of the sample are free except for the bottom face which is driven harmonically and uniformly. The model assumes a homogeneous and uniform material with Young modulus  $E$ , loss factor  $\eta$ , and Poisson ratio,  $\nu$ .

### 2.3: Inversion Code (Fortran)

The search for the 3 parameters ( $E$ ,  $\eta$ ,  $\nu$ ) that best describe the measured data is obtained by a three-dimensional direction-set method (Powell's method), a robust, classical method in optimization theory. The function that is minimized is the mean-square difference between the measured values (amplitudes and phases) of surface displacements relative to the base and the values predicted by the FEM code. (See block diagram Figure 2).

For more details, see Willis et al., JASA 102 (5), Nov 1997.

### 3) Experimental results

#### 3-1: Frequency dependent bulk and shear moduli and complex sound speeds

The frequency-dependent, complex sound speeds (shear and longitudinal) were *simultaneously* measured in the *same* sample in the 0.5 - 2.5 kHz range. (The frequency range could be lowered with a larger sample). The results are shown in Figure 3. (solid line). Note that the vertical scale is greatly expanded around the mean value, thus indicating the great precision of the technique.

#### 3-2: Error analysis

- Intrinsic variability (repeatability): A *statistical analysis* of the data, over 64 sets of data, was performed to measure the variance of the data obtained with the *same sample and the same measurement apparatus*. The resulting variance in the complex sound speeds was estimated. see Figure 1 (dashed lines). The dashed lines correspond to the sound speeds evaluated with the mean surface velocities  $\pm 1$  standard deviation. This shows that the error in amplitudes and phases of the measured surface velocities translate into variation of sound speeds less than 1%.

Relative error (*) (1.0-2.5 kHz)	real part	imaginary
Longitudinal sound speed	<1% (1%)	<1% (3%)
Shear sound speed	<1% (1%)	<1% (3%)

(\*) values indicate the typical average error over the frequency range. Values in parentheses indicate the maximum error in that frequency range.

- True variability between measurements (**same sample**): Tested the effect of the variability of bonding the sample to the base, i.e., repeated the measurements with the *same* sample, *before debonding and after rebonding* to the same base. In each case, the base was excited with a different drive: a Ling shaker and a piezoelectric stack. The relative errors measured with the same sample tested with the two drives (and with debonding and rebonding to the base) are shown in the table below.

Relative error (*) (1.0-2.5 kHz)	real part	imaginary
Longitudinal sound speed	3% (4%)	10% (13%)
Shear sound speed	3% (4%)	12% (20%)

(\*) values indicate the typical average error over the frequency range. Values in parentheses indicate the maximum error in that frequency range.

- True variability between measurements (**different samples**): Tested the method with *two samples* taken from the *same* piece of material, both with the same excitation (Ling shaker).

Relative error (*) (1.0-2.5 kHz)	real part	imaginary
Longitudinal sound speed	4% (5%)	10% (16%)
Shear sound speed	4% (5%)	10% (16%)

(\*) values indicate the typical average error over the frequency range. Values in parentheses indicate the maximum error in that frequency range.

- Comparison of the results with independent (in-situ) measurements made by Jarzynski et al. on a large chunk of the same material. Also, compared the results with Kerner's model in which the matrix material properties were calculated using experimental data obtained with the DMTA apparatus (results provided by Walt Madigosky).

results: (a) In situ results: Sound speeds are in reasonable agreement with our measurements, but at present, the in-situ results are only accurate within 10 to 20% and only the real part of sound speeds has been estimated.

(b) Kerner's model. The comparison with Kerner's simple model of voided polymers is not really meaningful because we don't know the material properties of the host material. (We had to estimate the properties from measurements made with the DMTA, measurements provided by W. Madigosky). Nevertheless, the comparison between measured values of sound speeds and predicted values was remarkably close.

- Spatial uniformity of the base motion (0.5 to 3 kHz). We compared the uniformity of several bases (including a wedge), and excitation by the Ling shaker, the B&K 4810 shaker, and several piezoelectric stacks.

*result:* The piezoelectric stack (Sensor Technology) performs best. A simple aluminum base to support the sample works best.

- Base assembly: We tested for the best combination of bondings between the piezoelectric stack, the back mass, the base, and the sample.

*result:* best results were obtained with the piezoelectric stack bonded to a massive lead brick using uncured butyl rubber; the aluminum base supporting the sample was attached to the stack with rubber cement; and the sample was super-glued to the base. With this arrangement, the nonuniformity of the base motion was less than 2% below 2 kHz and less than 4% at 3 kHz. (Results with the Ling shaker were worse.)

- Reflective tape. We assessed the effects of using small reflective tapes or small spots of white paint on the sample, for either in-plane or out-of-plane measurements.  
results: the effect appears negligible.
- *Sensitivity analysis on the position of each laser probe:* We performed numerical experiments (with measured data) to assess the relative contributions of the measurements made by each laser probe on the resulting material properties.
- *Sensitivity analysis of the numerical code:* We performed numerical experiments to test the dependence of the results on (a) the initial guesses of material properties (Young's modulus, loss factor, and Poisson ratio); and (b) the mesh size in the finite element code.

results: the material properties are independent of the initial guesses. They remain also identical if the mesh size is increased, thus indicating that the method is very robust and does not converge towards false minima.

#### **Personnel:**

R. Lance Willis, MS (graduated 95)  
 T. Shane Stone, MS (graduated 97)  
 Andrew C. Moore, MS (graduated 97)  
 Shawn Lin, MS (graduated 97)  
 R. Lance Willis, PhD  
 E. Hamilton, BS (minority student)

#### **Publications**

Berthelot, Y. H., Jarzynski, J., Kil, H. G., Willis, L., and Yang, M., "Laser interferometry for structural intensity," invited paper at the 129th meeting of the Acoustical Society of America, Washington, D.C., June 1995.

Yang, M., Jarzynski, J. and Berthelot, Y., "Optical detection of mode conversion in an L-shape beam," Proceedings of the 3rd International Congress on Air- and Structure-Borne Sound and Vibrations, Montreal, Canada (1994).

Kil, H.-G., Jarzynski, J. and Berthelot, Y., "Detection of propagating and evanescent elastic waves on a cylindrical shell from measurements of in-plane displacements with a scanning Laser Doppler Interferometer," Proceedings of the 3rd International Congress on Air- and Structure-Borne Sound and Vibrations, Montreal, Canada (1994).

Yang, M., Jarzynski, J., and Berthelot, Y. H., "The effect of surface characterization and laser beam polarization in Laser Doppler vibrometry," J. Acoust. Soc. Am. 96 (5) part 2, 3292 (1994). Presented at the 128th Meeting of the Acoustical Society of America, Austin, TX, November 1994.

Willis, R. L., Stone, T. S, and Berthelot, Y. H., "Acoustic material characterization by laser interferometry," presented at the 130th meeting of the Acoustical Society of America, St. Louis, MO, November 1995.

R. L. Willis, T. S. Stone, Y. H. Berthelot, and W. Madigosky, "An experimental-numerical technique for evaluating the bulk and shear dynamic moduli of viscoelastic materials," to appear in J. Acoust. Soc. Am., **102** (5), Pt 1., (1997)

T. S. Stone, "A numerical-experimental method for evaluating the bulk and shear complex dynamic moduli of viscoelastic polymers in the kilohertz range," M.S. thesis, Georgia Institute of Technology, September 1997.

S. H. F. Lin, "A laser interferometer for measurement of surface vibrations and ultrasound", M.S. thesis, Georgia Institute of Technology, September 1997.

A. C. Moore, "An improved system for measuring optically the surface dynamics of a sample", M.S. thesis, Georgia Institute of Technology, September 1997.

R. L. Willis, T. S. Stone, Y. H. Berthelot, "A laser-based experimental-numerical technique for evaluating the bulk and shear dynamic moduli of viscoelastic moduli," J. Acoust. Soc. Am. 101 (5), part 2, (1997); presented at the ASA meeting, Penn State University.

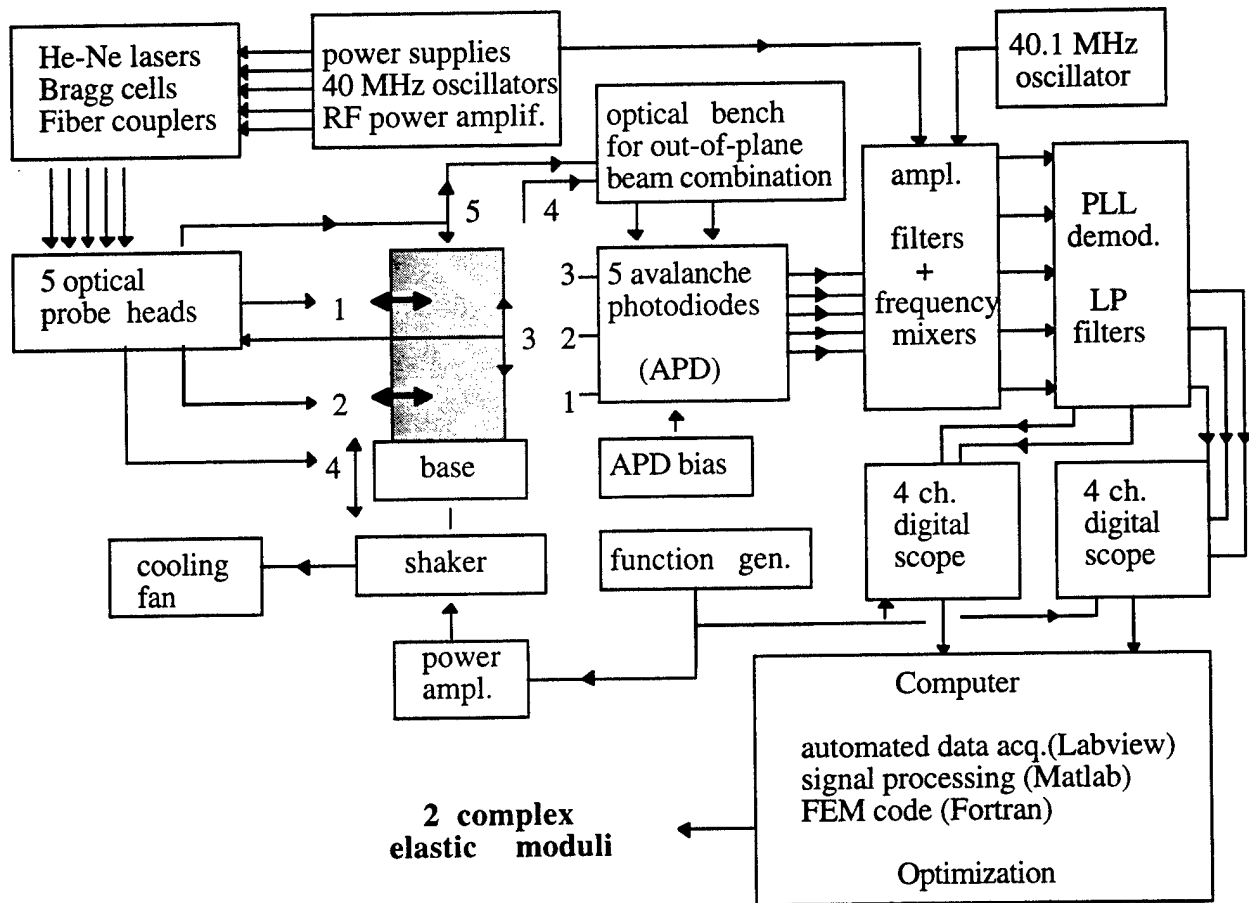

Figure 1: Experimental setup

@ each frequency,

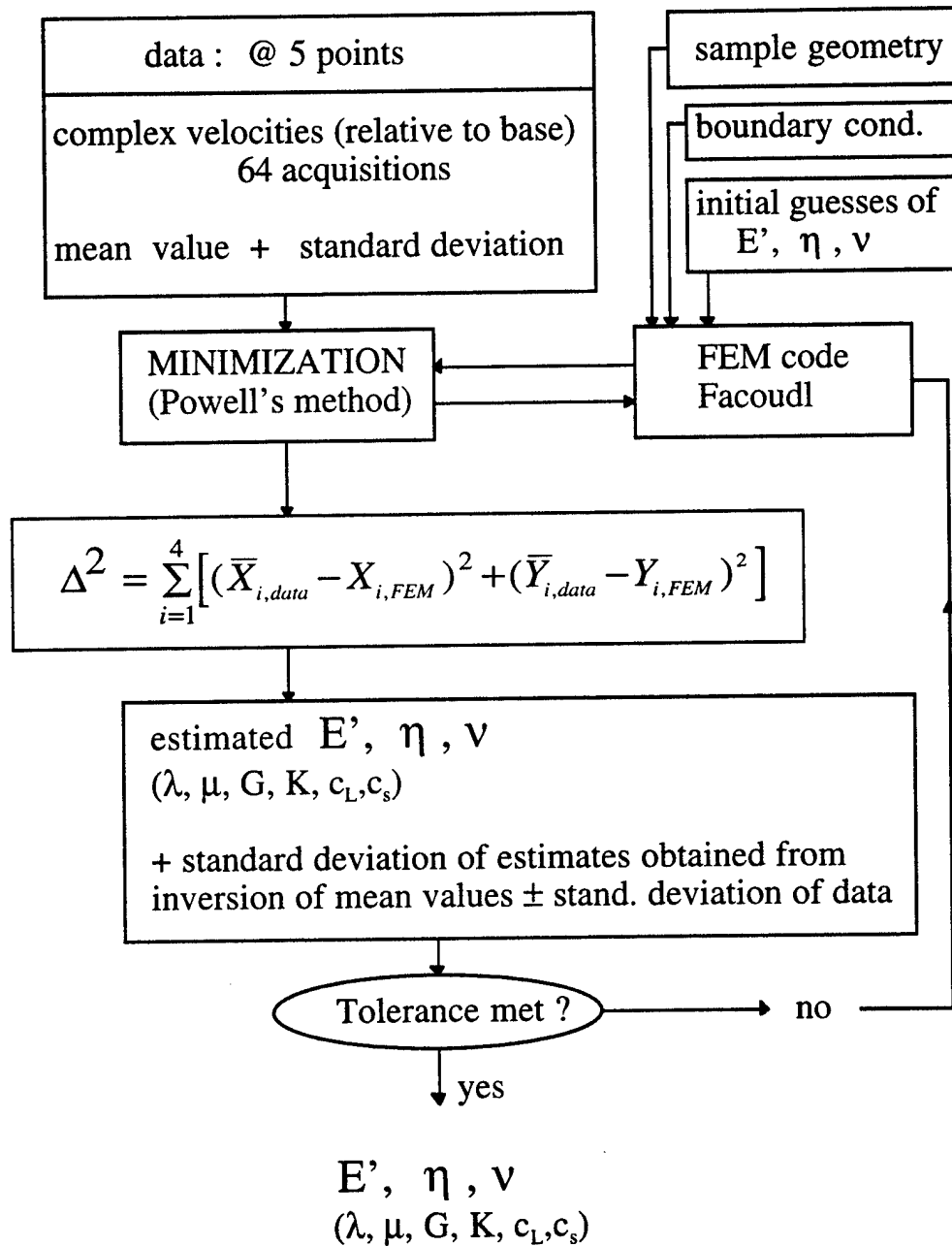

Figure 2: Block diagram of the experimental / numerical method

### Frequency-dependence of the complex sound speeds

solid line: sound speeds evaluated with the mean value of the surface velocities (64 acquisitions at each of the 5 surface points measured)

dotted lines: sound speeds evaluated with the mean value  $\pm 1$  standard deviation of the surface velocities (64 acquisitions at each of the 5 surface points)

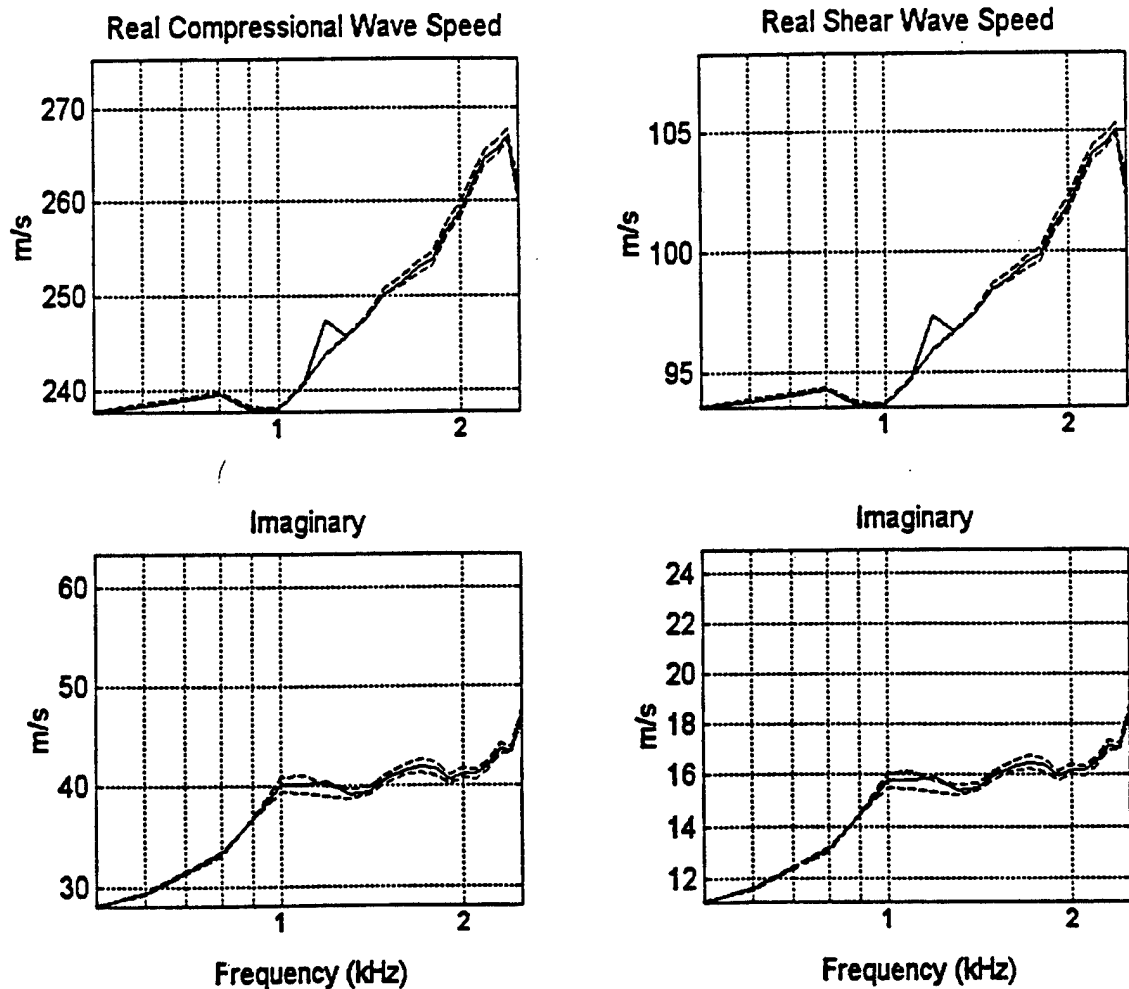

Figure 3

**Variability between 2 samples from the same batch.**  
**Frequency-dependence of the complex sound speeds**

solid line: sample #1 - dashed line: sample #2

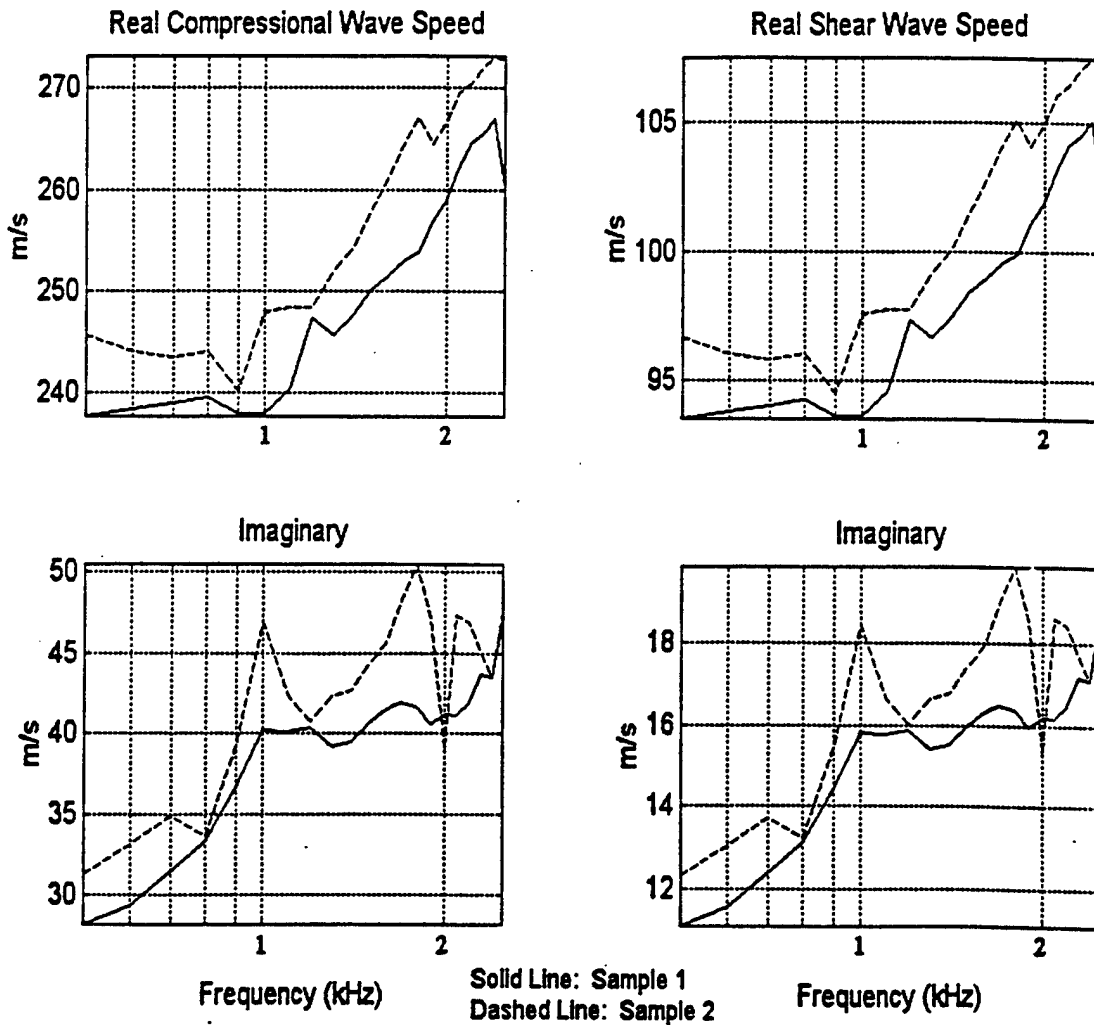

Figure 4

FORM A2-2  
**AUGMENTATION AWARDS FOR SCIENCE & ENGINEERING RESEARCH TRAINING (AASERT)**  
**REPORTING FORM**

The Department of Defense (DOD) requires certain information to evaluate the effectiveness of the AASERT program. By accepting this Grant Modification, which bestows the AASERT funds, the Grantee agrees to provide the information requested below to the Government's technical point of contact by each annual anniversary of the AASERT award date.

1. Grantee identification data: (R & T and Grant numbers found on Page 1 of Grant)

- a. GEORGIA INSTITUTE OF TECHNOLOGY  
 University Name
- b. 02-103-025-94-033                      c. 432p006...16  
 Grant Number                                      R & T Number
- d. Dr YVES H. BERTHELOT                      e. From: 07-01-96 To: 08-30-97  
 P.I. Name    AASERT Reporting Period

NOTE: Grant to which AASERT award is attached is referred to hereafter as "Parent Agreement."

2. Total funding of the Parent Agreement and the number of full-time equivalent graduate students (FTEGS) supported by the Parent Agreement during the 12-month period prior to the AASERT award date.

- a. Funding:                      \$ 92,490
- b. Number FTEGS:              1

3. Total funding of the Parent Agreement and the number of FTEGS supported by the Parent Agreement during the current 12-month reporting period.

- a. Funding:                      \$ 96,000
- b. Number FTEGS:              1

4. Total AASERT funding and the number of FTEGS and undergraduate students (UGS) supported by AASERT funds during the current 12-month reporting period.

- a. Funding:                      \$ 76,720
- b. Number FTEGS:              3
- c. Number UGS:                      0

**VERIFICATION STATEMENT:** I hereby verify that all students supported by the AASERT award are U.S. citizens.

Y. Jathens  
 Principal Investigator

11-25-97  
 Date