

REPORT DOCUMENTATION PAGE

Form Approved OMB No. 0704-0188

Public reporting burden for this collection of information is estimated to average 1 hour per response, including the time for reviewing instructions, searching existing data sources, gathering and maintaining the data needed, and completing and reviewing the collection of information. Send comments regarding this burden estimate or any other aspect of this collection of information, including suggestions for reducing this burden to Washington Headquarters Services, Directorate for Information Operations and Reports, 1215 Jefferson Davis Highway, Suite 1204, Arlington, VA 22202-4302, and to the Office of Management and Budget, Paperwork Reduction Project (0704-0188), Washington, DC 20503.

1. AGENCY USE ONLY (Leave blank)		2. REPORT DATE September 1997	3. REPORT TYPE AND DATES COVERED Conference Proceedings	
4. TITLE AND SUBTITLE First International Induced Gamma Emission Workshop			5. FUNDING NUMBERS F6170897W0053	
6. AUTHOR(S) Conference Committee				
7. PERFORMING ORGANIZATION NAME(S) AND ADDRESS(ES) Institute of Atomic Physics -IFTAR P.O. box MG-6 Bucharest, Magurele 76900 Romania			8. PERFORMING ORGANIZATION REPORT NUMBER N/A	
9. SPONSORING/MONITORING AGENCY NAME(S) AND ADDRESS(ES) EOARD PSC 802 BOX 14 FPO 09499-0200			10. SPONSORING/MONITORING AGENCY REPORT NUMBER CSP 97-1014	
11. SUPPLEMENTARY NOTES				
12a. DISTRIBUTION/AVAILABILITY STATEMENT Approved for public release; distribution is unlimited.			12b. DISTRIBUTION CODE A	
13. ABSTRACT (Maximum 200 words) The Final Proceedings for International Workshop on Induced Gamma Emission - IGE'97, 16 August 1997 - 20 August 1997 The Topics covered include: induced gamma emission, gamma-ray laser, ultra-high energy density materials, and ultrashort wavelength lasers.				
14. SUBJECT TERMS Lasers, Electromagnetics, Electromagnetic Materials			15. NUMBER OF PAGES 118	
			16. PRICE CODE N/A	
17. SECURITY CLASSIFICATION OF REPORT UNCLASSIFIED	18. SECURITY CLASSIFICATION OF THIS PAGE UNCLASSIFIED	19. SECURITY CLASSIFICATION OF ABSTRACT UNCLASSIFIED	20. LIMITATION OF ABSTRACT UL	

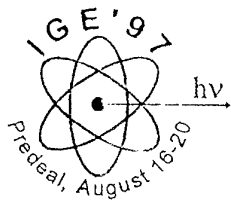

ICIGE
International Commission
on Induced Gamma Emission

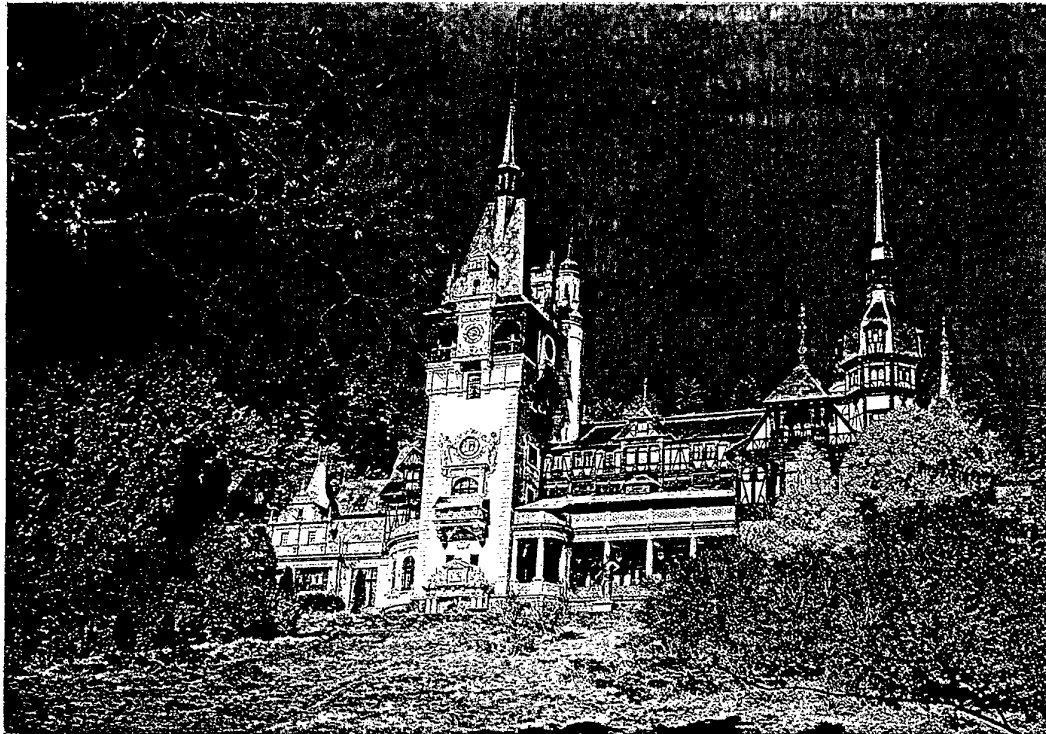

**FIRST INTERNATIONAL
INDUCED GAMMA EMISSION
WORKSHOP**

**Predeal, Romania
August 16 - 20, 1997**

TECHNICAL DIGEST

CSP 97-1014

F61708-97-W0053

DTIC QUALITY INSPECTED 4

DISTRIBUTION STATEMENT A

**Approved for public release;
Distribution Unlimited**

19971209 023

ICIGE - International Commission for Induced Gamma Emission

RC-IGE Foundation - Romanian Center for Induced Gamma Emission

P.O. Box MG - 6,
R-76900 Bucharest-Magurele
ROMANIA
Fax: + (401) - 420 9101
E-mail: icige@roifa.ifa.ro

© RC-IGE Foundation, 1997

All rights reserved. No part of this Technical Digest may be reproduced, stored in a retrieval system or transmitted in any form or by any means, electronic, mechanical, photocopying, recording or otherwise, without the prior permission of the RC-IGE Foundation. Individual abstracts remain the property of the authors.

INDUCED GAMMA EMISSION (IGE'97)

Technical Digest of the 1st International Induced Gamma Emission Workshop (IGE'97)
(Predeal, Romania, 16-20 August 1997)

REPRODUCTION QUALITY NOTICE

This document is the best quality available. The copy furnished to DTIC contained pages that may have the following quality problems:

- **Pages smaller or larger than normal.**
- **Pages with background color or light colored printing.**
- **Pages with small type or poor printing; and or**
- **Pages with continuous tone material or color photographs.**

Due to various output media available these conditions may or may not cause poor legibility in the microfiche or hardcopy output you receive.

If this block is checked, the copy furnished to DTIC contained pages with color printing, that when reproduced in Black and White, may change detail of the original copy.

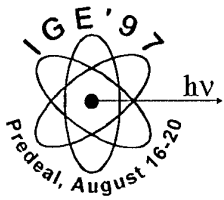

ICIGE
International Commission
on Induced Gamma Emission

TECHNICAL DIGEST
for
**FIRST INTERNATIONAL
INDUCED GAMMA EMISSION
WORKSHOP
IGE'97**

**Predeal, Romania
August 16 - 20, 1997**

Organized by

**Romanian Center for Induced Gamma Emission, RC-IGE
Bucharest, ROMANIA**

Sponsored by

**US Air Force European Office
for Aerospace Research and Development (EOARD)**

Sandia National Laboratories (USA)

Scientific Advisory Board

T. ARISAWA *JAERI Kansai Inst., JAPAN*
CH. BRIANÇON *CSNSM, Orsay, FRANCE*
C. B. COLLINS *University of Texas at Dallas, USA*
R. COUSSEMENT *Katholieke Universiteit Leuven, BELGIUM*
G. R. HOY *Old Dominion University, USA*
YU. TS. OGANESSIAN *JINR, Dubna, RUSSIA*
L. A. RIVLIN *MIREA, Moscow, RUSSIA*
A. SANDULESCU *Academy, ROMANIA*
V. I. ZORAN *IPNE - "Horia Hulubei", ROMANIA*

Program Co-Chairs

J. J. CARROLL *Youngstown State University, USA*
A. A. ZADERNOVSKY *MIREA, Moscow, RUSSIA*

Organizing Committee

Romanian Center for Induced Gamma Emission, RC-IGE
Bucharest, ROMANIA

I. IOVITZ POPESCU **Director**
R. PRESURA **Deputy**
C. UR **Scientific Secretary**
E. CRACIUN **Secretary**

CONTENTS

REVIEWS 1

- CARROLL, J.J., COLLINS, C.B.
Prospects for induced gamma emission triggered by incoherent pumping 1
- COLLINS, C.B., RIVLIN, L.A.
Essential fundamentals of quantum nucleonics 3
- RIVLIN, L.A.
Gamma-ray lasing by free nuclei: further concept elaboration 5

PUMP MECHANISMS 7

- AGEE, F.J.
Induced gamma emission of isomers: Triggered decay of X-rays and potential outcomes 7
- ZADERNOVSKY, A.A.
Two-quantum Doppler-free induced gamma emission 9
- ZORAN, V.
In-flight excitation of nuclear isomeric states: the method of equivalent photons 11
- VYSOTSKII, V.I.
On the possibility of highly effective gamma-laser nuclei excitation by nonthermal laser produced subrelativistic oscillating electrons during action of short powerful polarized optical laser pulse on a perfect oriented crystal 13
- ANDREEV, A.V., GORDIENKO, V.M., SAVEL'EV, A.B.
Nuclear transition excitation in high-temperature near-surface plasma: feasibility of gamma lasing 15
- MAKSYUTA, N.V.
On the possibility of gamma-laser pumping occurring at a charged particles counter motion and density-modulated electron beams by a super-rigid intense radiation 17

CANDIDATE STRUCTURE

19

BRIANÇON, CH.

Physics with the $^{178m2}\text{Hf}$ high-spin isomer

19

KARAMIAN, S.A., COLLINS, C.B., CARROLL, J.J., ADAM, J.

Measurement of the isomeric-to-ground state ratio in the reaction $^{180}\text{Td}^m(\gamma, \gamma')^{180}\text{Td}^{g(m)}$

21

ISRAILEV, I.M., POLITOV, V.YU.

On the possibility to measure the cross-sections of nuclear gamma-transitions, excited by X-ray tube radiation

23

TONCHEV, A.P., GANGRSKY, YU.P., BELOV, A.G., NOVGORODOV, A.F.

Photomuclear reactions on high-spin isomeric targets

25

PUMP SOURCES

27

ARISAWA, T.

Progress in the research program on advanced photon science

27

GANCIU, M., COLLINS, C.B., PENACHE, M.C., PENACHE, D., ZORAN, V.,
POPESCU, I.-IOVITZ*Filamentary X-ray sources by "Cruise Effect"*

29

MANDACHE, N., NISTOR, M., POPESCU, I.-IOVITZ, UDREA, S.,
GANCIU, M., POINTU, A.M., DEWALD, E., FRANK, K., HOFFMANN, D.H.H.*Intense electron beams in open ended hollow cathode transient discharges for table top X-ray sources*

31

HENING, A.

Development of an excimer laser driven soft X-ray source; applications to soft X-ray lithography and holography

33

POTYLITSIN, A.P.

Compton backscattering of coherent diffraction radiation as an intense X-ray source

35

MÖSSBAUER AND COLLECTIVE EFFECTS

37

COUSSEMENT, R., ODEURS, J., NEYENS, G., L'ABBÉ

Coherence in nuclear radiation

37

ODEURS, J., COUSSEMENT, R., NEYENS, G.

Cooperative effects in stimulated gamma emission

39

ALPATOV, V.G., BAYUKOV, YU.D., DAVYDOV, A.V., ISAEV, YU.N., KARTASHOV, G.R.,
KOROTKOV, M.M., SAMOYLOV, V.M.*Status of the experiments on gravity and earth magnetic field effects on the ^{109}Ag γ -resonance*

41

ALPATOV, V.G., BORZAKOV, S.B., DAVYDOV, A.V., ISAEV, YU.N., KARTASHOV, G.R., KOROTKOV, M.M., NAZAROV, V.M., PAVLOV, S.S., PERESEDOV, V.F., RAD'KO, V.E., SAMOYLOV, V.M., CHINAEVA, V.P. <i>Excitation of the long living isomers $^{107m,109m}\text{Ag}$ in the fast neutron inelastic scattering reactions</i>	43
ALPATOV, V.G., DAVYDOV, A.V., ISAEV, YU.N., KARTASHOV, G.R., MEMELOVA, L.YA., SADOVSKY, A.A., TRET'YAKOVA, N.I. <i>Measurement of the Mössbauer factor f for ^{125}Te γ-rays in beryllium telluride</i>	45
ANDRIANOV, S.N., SAMARTSEV, V.V. <i>Quadrupole gamma superradiance</i>	47
ANDRIANOV, S.N., SAMARTSEV, V.V. <i>Gamma superradiance stimulated by laser cooling</i>	49
ENACHI, N.A., MACOVEI, M.A. <i>Cooperative gamma-ray generation stimulated by X-ray pulse</i>	51
SADYKOV, E.K., ALEXEEV, S.A., ZAKIROV, L.L. <i>Gamma-spectroscopic transitions controlled by radiofrequency fields</i>	53
VAGIZOV, F.G., MANAPOV, R.A., SADYKOV, E.K., ZAKIROV, L.L. <i>Radiofrequency modulation of ^{57}Fe hyperfine interactions by rotating magnetic field</i>	55
GITSOVICH, V.N., SEMENOV, V.G., SERGEEV, I.A., SKOROBOGATOV, G.A. <i>Coherent resonant scattering under total external reflection</i>	57
SKOROBOGATOV, G.A., ROMASHEV, YU.A. <i>A cooperative mechanism of IGE in a polycrystal matrix containing Te-^{125m}, Te-^{123m}, etc.</i>	59
CHEREPANOV, V.M., CHUEV, M.A., GUDENKO, S.V., KAPELNITSKII, S.V., YAKIMOV, S.S. <i>First observation of double ESR - Mössbauer resonance in $\text{Al}(\text{NO}_3)_3 \cdot 9\text{H}_2\text{O} : ^{57}\text{Fe}(3+)$ single crystal in regime of mixed electron-nuclear transitions</i>	61
MITIN, A.V. <i>Quantum beat spectroscopy of modulation harmonics in gamma magnetic resonance</i>	63
MOISEEV, S.A., AGANIN, A.A. <i>About sonoluminescence effect as a possible way of gamma-ray laser pumping</i>	65
MOISEEV, S.A. <i>Temporal properties of the quantum collapse at the coherent interaction of the photon with resonant nuclear system</i>	67
ZARETSKY, D.F., SAZONOV, S.B. <i>The coherent repopulation of hyperfine levels and induced gamma emission</i>	69

OLARIU, S., OLARIU, A. <i>Induced emission of gamma radiation from nuclear isomers</i>	71
OLARIU, S., OLARIU A., ZORAN, V. <i>Emission of gamma rays by X-ray electron-nuclear double transitions</i>	73
QUENTIN, P., LIBERT, J., PILLET, N., PONS, A <i>Single particle structure of high-K isomers in $A \sim 178-180$ nuclei</i>	75
ZHU, L.J., YUAN, Z.S., PAN, Z.Y., HO, Y.K. <i>Nuclear non-axial excitations and K-mixing states</i>	77
ROSTOVTSEV, YU., KOLESOV, R., KOCHAROVSKAYA, O. <i>Inversionless gain at γ-ray transition via nuclear coherence created by optical driving</i>	79
VYSOTSKII, V.I. <i>The theory of controlling the spontaneous nuclear gamma-decay and lifetime of radioactive and excited nuclei</i>	81
VYSOTSKII, V.I., BUGROV, V.P., KORNILOVA, A.A., REIMAN, S.I. <i>The experimental realization and investigation of the effect of controlling and changing the lifetime of gamma-excited nuclei</i>	83
SOKOLYUK, I.V., ZAJAC, T.M. <i>The investigation of the mechanism for excitation of metastable states of nuclei during inelastic scattering reaction of γ-quanta on the nucleus</i>	85
SOKOLYUK, I.V., ZAJAC, T.M. <i>Influence of nucleus shell structure fpg-shell for excitation metastable states in (γ, n) reaction</i>	87
ZAJAC, T.M., SOKOLYUK, I.V. <i>The isomeric state of $^{178}\text{Hf}(16+)$ theoretical studying</i>	89
SHAKHMURATOV, R.N. <i>Gamma-optics fibre created by coherent light</i>	91
ROMASHEV, YU.A., SKOROBOGATOV, G.A. <i>Semiclassical interaction between monochromatic electromagnetic radiation and an atom with two unstable levels</i>	93
GADOMSKY, O.N., KRUTITSKY, K.V., IDIATULOV, T.T. <i>Long-lived positronium in the field of an optical laser</i>	95
KARYAGIN, S.V. <i>Gamma-ray solid laser: steadiness against both the self-radiation defects and the self-heating</i>	97

MOISEEV, S.A. <i>About optical modeling of Mössbauer gamma-ray laser generation</i>	99
COHERENT SUBTHRESHOLD EMISSION	101
ZHIRKO, YU.I., KOZERATSKAJA, G.N., PETRENKO, T.M., VASIN, A.V., KIRISCHUK, V.I. <i>Search of the structures and compounds, useful for the self-stimulation detection in long-lived nuclear isomer decay</i>	101
STRILCHUK, N.V., KIRISCHUK, V.I. <i>An advanced technique of the search for the stimulated gamma-ray emission</i>	103
DZEVITSKII, B.E., GITSOVITCH, V.N., SEMENOV, V.G., SKOROBOGATOV, G.A. <i>Experimental technique for detection of induced gamma emission in transition $Te(125m, 2) \rightarrow Te(125m, 1) + \text{gamma} (109.27 \text{ keV})$</i>	105
RUNDBERG, R.S., FOWLER, M.M., TAYLOR, R.D., WILHELMY, J.B. <i>Cross section for the stimulated emission of 109.28 keV gamma rays from ^{125m}Te</i>	107
AUTHOR INDEX	109
20 blank pages for <i>NOTES</i>	111

**PROSPECTS FOR INDUCED GAMMA EMISSION
TRIGGERED BY INCOHERENT PUMPING**

J. J. Carroll

Center for Photon Induced Processes, Department of Physics and Astronomy,
Youngstown State University, Youngstown, Ohio 44555-3617, USA
e-mail: jjcarroll@cc.ysu.edu

and

C. B. Collins

Center for Quantum Electronics, University of Texas at Dallas
P. O. Box 830688, Richardson, Texas 75083-0688, USA
e-mail: cbc@utdallas.edu

The ability to trigger the emission of gamma rays from isomeric samples could have important consequences, and perhaps serve as a precursor to the long-sought-after gamma-ray laser. This possibility rests on the unique advantages of nuclear transitions which provide exceptional energy storage in isomers, and experimental and theoretical results that indicate incoherent "optical" pumping with low-energy x rays may provide an effective trigger mechanism [1]. Experiments have already shown that nuclear isomers can be excited by a multiple-step process in which photons of hundreds to thousands of keV first pump a population to a higher-lying state, or gateway, followed by efficient branching of the gateway to the isomer. Also, the reverse reaction, triggering the energy release from an isomer as the initial state, has been demonstrated by producing induced gamma emission (IGE) from nature's rarest stable material, $^{180}\text{Ta}^m$. Systematics developed from these experiments have shown a consistency in the mass-180 region for the appearance of gateways with extremely large integrated cross sections near 2.8 MeV above the ground state. These gateways are often called "K-mixing levels" in reference to the need to bridge transitions in deformed nuclei which would otherwise be expected to be strongly inhibited by large ΔK . Based on these results, the 31-year, 16^+ isomer $^{178}\text{Hf}^{m2}$ has been identified as the best candidate for efficient triggering of induced gamma emission by x rays as its excitation energy of 2.45 MeV lies within 300 keV of the likely gateway energy. This conclusion has been strengthened by focused systematics for isomers of nearby Hf isotopes and recent experiments identifying similarly-located levels for spontaneous decays of isomers in neighboring nuclides. This presentation will survey these analyses, current and future experiments.

1. C. B. Collins and J. J. Carroll, *Hyperfine Int.* **107**, 3 – 42 (1997), and references cited therein.

ESSENTIAL FUNDAMENTALS OF QUANTUM NUCLEONICS

C. B. Collins

Center for Quantum Electronics, University of Texas at Dallas
P. O. Box 830688, Richardson, Texas, 75083-0688, USA

L. A. Rivlin

Moscow State Institute of Radio Engineering, Electronics, and Automation
78 Vernadsky Ave., Moscow, 117454, RUSSIA

Abstract Quantum nucleonics is the study for electromagnetic transitions in nuclei that is most analogous to quantum electronics for atoms. It is rich with potential for application and here we direct particular attention to the nuclear analogs of spin-metastable helium to illuminate the potential utility of two and four quasiparticle isomeric nuclei.

The movement of charged particles in confined volumes leads to the emission of electromagnetic radiation. Electrons in antennas emit radio waves and microwaves, while electrons moving in molecules and atoms radiate photons of infrared, light, or x-rays. At small scales the motions of charges are quantized and such electromagnetic radiations are emitted as photons (the simplest of the bosons) during transitions between the discrete levels of energy storage that are allowed in the confined volumes. Within the smaller domain of the nucleus, two types of charges are capable of independent "movement;" the concentrations of positive charge associated with the protons, and the neutron "holes" in the average charge of the nuclear fluid which must act as localizations of relatively negative charge. The transitions between the quantized states of excitation of either (or both) lead to the emission or absorption of electromagnetic radiation known as gamma rays. However, the lowest energies of gamma radiation overlap the highest energies of x-rays and, once emitted; for those energies there is no distinction between photons arising from atoms and those emitted from nuclei.

The same rules of electromagnetic radiation apply to all systems, so in principle, excited states of nuclei could be stimulated to emit their stored energy coherently. A gamma-ray laser would be only the most straightforward result; and analogs of many of the more elegant phenomena of quantum electronics should be expected. Unfortunately, because of the unfamiliar perspectives arising from the strongly interdisciplinary nature of such problems, it is customary to feel that despite abundant evidence to the contrary, nuclei are somehow "shielded" by the electrons and cannot be "seen" by radiation emitted by non-nuclear sources. Originally, results of investigations along the traditional lines of nuclear physics were quite negative in their conclusions, despite the fact they were reporting that ratios of cross sections for resonant nuclear to non-resonant (electronic) interactions of photons with matter actually ranged from 100 to 10,000 across the table of the elements [1]. Nevertheless, from the first proposal for a gamma-ray laser [2] as detailed in an early review [3] it has been clear that an interdisciplinary perspective drawing from quantum electronics, materials science, and nuclear physics could advance the quest for the control of the interactions of photons with nuclei without the need for nuclear reactions involving fission, fusion or energetic material particles. We believe that progress in this field will give birth to a new branch of science and technology [4], *QUANTUM NUCLEONICS* - that should extrapolate quantum electronics and nonlinear optics into a new range of high photon energies and new quantum amplifying media. The particular aspects of this field that are of interest here are the prospects for Induced Gamma Emission, IGE. There are many attractive analogies with photon

interactions at the atomic level which help to illuminate the fundamental principles.

In all cases the cross section for the interaction of electromagnetic radiation with matter is described by the Breit-Wigner cross section (which is of the order of the square of the wavelength) reduced by effects of recoil, Doppler broadening, and reductions in the lifetimes of the excitation of the material states caused by environmental effects. In the familiar domain of optical frequencies, the latter effects dominate to such an extent that the actual cross section for the stimulated emission of a photon by Nd ions in YAG is over an order of magnitude smaller than comparable interaction of 14.4 keV photons with Fe-57 nuclei in a foil of iron under Mossbauer conditions which prevent recoil and thermal motion of the nuclei. The electrons in the iron do not shield the nucleus because the peak cross sections for interaction of the electrons with the radiation are greatly reduced by broadening, as in the case of the YAG. While the Mossbauer effect is the most obvious ally in the attempts to control the interaction of photons with nuclear states, there are many others which hold even greater promise.

Even within the quantized structures in the matter interacting with the radiation, there is more similarity between the nuclear and atomic domains than might be first expected. At the simplest level of approximation, in the former the two types of charges move in the spherical oscillator potential, while the electrons move in the Coulomb potential. While this appears to be a major difference, both cases lead to basis state descriptions using somewhat different exponential and hypergeometric functions of radial positions and the same spherical harmonics. Of course, the precise radial distributions and the positions of nodes are different, but in a general view these do not dominate behavior. Electromagnetic transition rules depend upon the angular parts and so the same selection rules result. The important differences arise in more subtle ways. First in the Coulomb case, there is an "accidental selection rule in the combination of radial and angular quantum numbers. In the notation of $|NLM\rangle$, this means $(N-L) > 0$. To the contrary for spherical oscillator bases, 1d, 2f, and even 1h states are perfectly allowable. In contrast to the hydrogenic spacing of atomic levels in energy, for the spherical oscillator, $E = (N+L/2+3/2)h\nu$, where $h\nu$ is of the order of a few MeV. However, the most significant differences are twofold. The first arises from the fact that the scale of the nucleus is so much smaller than for atoms. Because of the uncertainty principle, the velocities (and so the magnetic effects) will be much larger in nuclei. This means that spin-orbit coupling will be of dominant importance in nuclear structure. Secondly, coupling to the radiation field will be significant for many electric and magnetic moments. Statistically, the most probable type of transition at the nuclear level is the magnetic dipole. A continuation of this inspection of the analogs in quantum nucleonics suggests strong parallels between the atomic metastables such as triplet He and interesting two and four quasiparticle isomers of Hf. From this perspective it can be argued that nuclear transitions have considerable advantage over atomic and molecular analogs for the further development of quantum optics.

1. Baldwin G.C., Solem J.C., Gol'danskii V.I., Rev. Mod. Phys., 53, 687, 1981.
2. Rivlin L., A. Author's Certificate # 621 265, appl. January 10, 1961; publ. June 25, 1979 (Byull. Izobret. # 23, 220, 1979 -in Russian)
3. Collins C.B. et al., J. Appl. Phys., 53, 4645, 1982.
4. C. B. Collins and L. A. Rivlin, Laser Phys., 6, 617, 1996.

GAMMA-RAY LASING BY FREE NUCLEI: FURTHER CONCEPT ELABORATION

Lev A. Rivlin

Moscow State Institute of Radio Engineering, Electronics, and Automation

(Technical University) = MIREA

78 Vernadsky Ave., Moscow 117454, Russia

E-mail: rla@superlum.msk.ru

We present more detailed than in previous reports a quantitative analysis of the feasibility of a self-consistent experimental scheme of gamma-ray lasing (GRL) in the populations of free isomer nuclei with hidden inversion or under the influence of external X-ray ignition.

Two years ago, at the First GRL Workshop'95, we have presented the concept of Free Nuclei Gamma-Ray Lasing as an alternative approach to the known Mössbauer version. This approach implies first of all to overcome the pernicious influence of Doppler line broadening in two different ways: using the lasing medium with hidden inversion or the external ignition of the avalanche two-quanta gamma-emission.

We consider the feasibility of elaboration of the self-consistent experimental scheme, paying attention strictly to some aspects of the lasing process itself, in particular:

- Methods of lowering the gamma-lasing threshold.
The gamma-photon losses caused by photoeffect and Compton scattering are proportional to the number of electrons contained in all the atoms no matter what kind of nuclei (excited or unexcited). In the case of hidden inversion, the unexcited nuclei are even more numerous than the excited ones. Hence, they strongly raise the losses and consequently heighten the lasing threshold. It is possible to eliminate this negative influence taking into account the different motion parameters of excited and unexcited free nuclei arising as a result of pumping. This difference is sufficient for the discrimination by known optical-laser methods and possibly may lead to the development of some kind of cleansing active nuclear ensemble providing the lowering of the threshold.
- Methods of creation of isomer ensembles with hidden inversion based on the external modulation of atom motion.
The appearance of such kind of inversion due to an unhomogeneous deformation of emission and absorption lines of the Mössbauer's nuclides in solids arising under influence of forced atom motion was predicted more than 15 years ago. An effect of similar type in the populations of free nuclei is seemingly even more efficient than in solids.
- Analysis of suitability of isomers with $0 - 0$ transitions (i.e. with zero spins of both states) for the two-quantum GRL with external ignition.
The one-quantum radiative transition between such pair of states is completely forbidden. Hence the ensemble of this kind of metastable nuclei is almost the perfect medium for actualizing the stimulated two-quanta transitions of low multipole order (for instance, dipole + dipole), if various possible obstacles (say, the competing internal conversion process) are not too vigorous.
- Methods of increasing the efficiency of noncoherent X-ray sources destined for pumping and igniting, because all the known sources are not up to the mark even if one tries to make use of such unique transitions as so called Giant Texas Resonances.
- Estimates of minimum number of isomer nuclei providing the reliable observation of the GRL-effect; etc.

The research described herein was supported in part by EOARD, project SPC-96-4033 and by the Russian Foundation for Basic Research, project 96-02-17686.

**INDUCED GAMMA EMISSION OF ISOMERS:
TRIGGERED DECAY OF X RAYS AND POTENTIAL OUTCOMES**

Forrest J. Agee

US Air Force Research Laboratory, Phillips Laboratory, Attn. (PL/WSQ),
3550 Aberdeen Ave., Kirtland AFB, NM 87117, USA

Spin isomer researchers have made substantial progress in understanding techniques that can be used to cause transitions in nuclear isomeric states. This paper reviews progress to date and looks at the possible decay schemes for a leading candidate isomer. Various possible decay schemes are discussed in terms of the implications for useful applications. The results provide useful guidance for planning experimental and theoretical efforts that would make possible the realization of the potential of nuclear isomers as energetic materials and media for a gamma ray laser. Plans for experimental investigations underway at several university laboratories in collaboration with the Phillips Laboratory are discussed.

TWO-QUANTUM DOPPLER-FREE INDUCED GAMMA EMISSION

A. A. Zadernovsky

Moscow State Institute of Radio Engineering, Electronics, and Automation

(Technical University) = MIREA

78 Vernadsky Ave., Moscow 117454, Russia

E-mail: a.z@relcom.ru

Detailed analysis has been made on two-quantum induced gamma emission (IGE) of free excited nuclei ignited by counterpropagating photon beams. In contrast to one-quantum emission with Doppler-broadened line, all nuclei, regardless of their random individual velocities, turn out to be involved in the process of two-quantum IGE of photons with the energies close to half of the nuclear transition energy. A specific distributed feedback, inherent to two-quantum emission only, is settled without any reflecting structures. This leads to avalanche-like release of nuclear storage energy accompanied by emission of a giant pulse of coherent gamma quanta.

As it is well known, the cross section for induced emission is rapidly decreasing in the high frequency range because of both the decrease of the emission wavelength and the increase of the Doppler line width which is proportional to the transition frequency. Therefore, observing IGE seems unlikely without radical suppression of the Doppler broadening of the emission line. In the most proposals for gamma-ray lasing, the Mössbauer recoilless transitions of nuclei in solids are suggested in order to avoid thermal broadening of emission lines and, thus, to increase the IGE cross section. However, the lack of success of long standing efforts to observe efficient IGE in solids impels the search for new approaches alternative to the traditional schemes based on the Mössbauer technique. In this paper we discuss a way to remove the negative role of chaotic motion of nuclei by ignition of two-quantum IGE in counterpropagating intense photon beams. This method is based on a rich experience of sub-Doppler two-quantum optical absorption spectroscopy [1].

According to the laws of energy and momentum conservation, any nucleus, regardless of its velocity, is capable to absorb (or emit) simultaneously two quanta with opposite wave vectors directions and with the same energies equal to half of the nuclear transition energy. The Doppler shifts to the frequencies of such quanta are equal in value but opposite in sign. Therefore, a motion of nuclei can not rule out the sum of the quanta energies beyond the resonance with the nuclear transition energy. Thus, the spectral distribution of two-quantum IGE under condition of external ignition by counterpropagating beams of photons of equal energies will feature a narrow peak close to half of the transition energy. This peak is associated with the contribution to IGE of all nuclei, regardless of their random individual velocities, and is in contrast with the background formed by the emission of particular groups of nuclei belonging to different parts of their velocity distribution.

The dynamics of the counterpropagating photon beams amplification is governed by the rate equations. In the stationary case they can be reduced to the transcendent equation for the net output photon flux density I_n on the length L [2]:

$$2 \left(\frac{I_n}{I_s} + \frac{2I_i}{I_s} \right)^{-1} \ln \left(1 + \frac{I_n}{I_i} \right) + \frac{I_n}{I_s} = \beta n_0 I_s L \quad (1)$$

where n_0 is the initial population difference, β is the rate constant for induced gamma emission and I_s, I_i are the saturation and igniting photon flux densities, respectively.

The solution of Eq. (1) reveals an ambiguous S -like dependence of normalized net output photon flux density I_n/I_s versus the product $\beta n_0 I_s L$. As the product reaches its critical value $(\beta n_0 I_s L)_{cr} \sim 1$, the output photon flux density is switched to the upper branch of the S -like curve. This process is accompanied by abrupt avalanche-like devastation of the upper level population, which gives rise to a burst generation of a giant pulse of coherent gamma quanta. The critical igniting photon flux density can be estimated by: $I_i/I_s = 2/(\beta n_0 I_s L)_{cr}$. Using the evaluation $\beta = (2 \cdot 10^{-40} \text{ cm}^4)/\Delta\omega_0$, for a nucleus with $A = 150$, where $\Delta\omega_0$ is the nuclear transition spectral width and assuming $n_0 = 10^{17} \text{ cm}^{-3}$ and $L = 10^4 \text{ cm}$, we obtain $I_i/\Delta\omega_0 = 4 \cdot 10^{18} \text{ cm}^{-2}$.

Within the framework of the approach under consideration the problem of positive feedback between counterpropagating waves of gamma radiation could be solved without any reflecting structures, creation of which is a very complicated task in gamma frequency range. Indeed, due to intrinsic nonlinearity of two-quantum emission the counterpropagating waves of IGE proved to be perfectly matched in phase and coupled to each other. This coherent coupling arising in each event of two-quantum IGE can be regarded as a some kind of positive distributed feedback, which leads to forming a standing wave in the amplification region (the main attribute of a feedback) in the absence of any mirrors or periodic scattering structures.

The research described herein was supported in part by EOARD, project SPC-96-4032 and by the Russian Foundation for Basic Research, project 96-02-17686.

1. Y.R. Shen, *The Principles of Nonlinear Optics*, New York, 1983, ch. 12
2. L.A. Rivlin, A.A. Zadernovsky, *Induced Two-Quantum Gamma Emission of Free Nuclei under Conditions of External Ignition*, *Laser Physics* 6 (5), 956-962 (1996)

**IN-FLIGHT EXCITATION OF NUCLEAR ISOMERIC STATES;
THE METHOD OF EQUIVALENT PHOTONS**

Valeriu Zorán

Institute of Physics and Nuclear Engineering,

Department of Atomic and Nuclear Physics

76900 Magurele, P.O. Box MG-6, Bucharest, Romania

In order to produce induced gamma emission rates comparable to the natural emission rates of isomeric nuclei, the spectral intensities of the photon fluxes must be very large. In this work it is assumed that the isomeric nuclei are incident upon a target at rest, and it is shown that large equivalent-photon fluxes can be produced by the Coulomb fields of the target nuclei at rest.

According to Eichler and Meyerhof [1] the number of equivalent photons per energy interval generated in an encounter between an incident isomeric nucleus and a target nucleus is

$$N(\hbar\omega) \cong \frac{2}{\pi} \frac{e^2}{\hbar c} \frac{Z^2}{\beta^2 \hbar\omega} \left[\ln \left(\frac{1.123\gamma v}{\omega b_{\min}} \right) - \frac{\beta^2}{2} \right], \quad (1)$$

where $\hbar\omega$ is the energy of the photons, Z is the proton number of the target nuclei, $\beta = v/c$, v is the velocity of the incident isomeric nucleus, $\gamma = (1-\beta^2)^{-1/2}$ and b_{\min} is the minimum impact parameter. The energy of the equivalent photons is of the order of $\hbar\omega = \hbar v / b_{\min}$.

The number of equivalent photons per energy interval and unit surface will be of the order of $N(\hbar\omega) / a^2$, where a is the interatomic distance of the target nuclei. If d is the thickness of the target, then the total number of equivalent photons per energy interval and unit surface will be of the order of $N(\hbar\omega)d / a^3$. For $Z = 50$ and $\hbar\omega = 1$ MeV, the number of equivalent photons per energy interval is of the order of 10^{-2} photons keV⁻¹, and for $d / a = 10^3$ and $a = 3 \times 10^{-8}$ cm the total number of equivalent photons per energy interval and unit surface is of the order of 10^{16} photons cm⁻² keV⁻¹. For an integrated induced gamma emission cross section $\sigma_i = 10^{-25}$ cm² keV, the probability of induced gamma emission for an incident isomeric nucleus is of the order of 10^{-9} . For $d / v = 10^{-14}$ s, the induced gamma emission rate is then of the order of 10^5 s⁻¹.

1. J. Eichler and W. E. Meyerhof, *Relativistic Atomic Collisions* (Academic Press, 1995), p. 54

**ON THE POSSIBILITY OF HIGHLY EFFECTIVE GAMMA-LASER NUCLEI
EXCITATION BY NONTHERMAL LASER-PRODUCED SUBRELATIVISTIC
OSCILLATING ELECTRONS DURING ACTION OF SHORT POWERFUL
POLARIZED OPTICAL LASER PULSE ON PERFECT ORIENTED CRYSTAL**

V. I. Vysotskii

Kiev Shevchenko University, Radiophysical Dept., 252033, Kiev, Ukraine

Abstract. The paper considers the problem of obtaining the highest population (10÷50%) of excited short-lived nuclear states due to direct Coulomb excitation of nuclei in perfect oriented crystal by nonthermal ultra-high current of oscillating subrelativistic electrons produced in the focus of powerful short polarized optical laser pulse.

The paper considers the motion dynamics and the action on the nuclei of ultra-high current of subrelativistic oscillating electrons produced in oriented quasi-cold crystals by focused short high power laser pulses. If the short (duration $\Delta t \leq 10^{-12}$ s) and focused (area of laser focus $\Delta S \leq 10^{-5}$ cm²) optical laser pulse with energy W acts upon the crystal, its electric field $E_0 = (4\pi W/\Delta S c \Delta t)^{1/2}$ can exceed the threshold ionization field $E_i \approx e/r_b^2$ of the atoms in the crystal. In this case the produced electrons will move synchronously with the laser field $\mathbf{E}_0 \cos(\Omega t - \mathbf{kr})$, i.e., periodically with subrelativistic velocity: $v = v_{\max} \sin(\Omega t - \mathbf{kr})$, $v_{\max} = (eE_0/m\Omega)$.

The electron system of the crystal thermalizes only at $t \geq \delta t_1 \approx 10^{-11}$ s, while the lattice of the crystal stays quasi-cold until $t \geq \delta t_2 \approx 10^{-8}$ s.

The following circumstances are important for this consideration:

1) Both free and ionization electrons with total concentration n^* at $t \leq \Delta t$ are oscillating. The amplitude of electron oscillations along \mathbf{E}_0 equals $\Delta x \approx (4\pi e^2 W/m^2 \Omega^4 c \Delta S \Delta t)^{1/2}$.

In case of a powerful laser ($\lambda \approx 1$ μm , $W/\Delta t \geq 10^{12}$ W) this amplitude reaches the values $\Delta x \approx 500 \div 1000$ \AA and exceeds the interatomic distance $d \approx 2$ \AA by several orders of magnitude.

2) For such a regime of coherent electron motion the kinetic energy of periodically moving electron averaged by the period of oscillation $2\pi/\Omega$ equals $\langle T_{\text{coh}} \rangle \approx \pi e^2 W/m\Omega^2 c \Delta S \Delta t \geq 50 \div 100$ keV. This allows us to consider the averaged plane and axis potentials instead of the system of discrete atoms.

Such simplification makes necessary to consider the influence of mutual orientation of the laser field \mathbf{E}_0 , the polarization, and the crystallographic direction of quasi-cold crystal (at $t \leq \Delta t \ll \delta t_2$) upon the motion of fast electrons and leads to the model (regime) of laser produced electron beam channeling with self-focusing of the moving electrons to the plane (axis) of the crystal and increasing of the moving electron density (beam density) in the volume of localization of nuclei and inside atomic electrons by $F \approx 5 \div 10$ times. If the laser wave polarization $\mathbf{e}_x = \mathbf{E}_0/E_0$ is parallel to the crystal axes or planes, the density of the current of laser generated fast electrons inside atoms equals $j_{\max} \approx n^* v_{\max} F \approx 10^{15}$ A/cm². In fact this system can be considered as a unique ultra-high-current subrelativistic periodical micro-accelerator.

3) For this regime of coherent motion the average $\langle T_{\text{coh}} \rangle$ and maximal $T_{\max} = 2\langle T_{\text{coh}} \rangle$ the electron energies exceed the equilibrium plasma electron energy $\langle T_{\text{eq}} \rangle = 3KT/2 \approx 0.5 \div 3$ keV with the same power $W/\Delta t$ (for longer pulses $\Delta t \gg \delta t_1$) by several orders of magnitude. Also it is possible using this regime to excite nuclear states (direct Coulomb excitation) with superthermal energy $\hbar\omega_{\text{sk}}^{(\max)} \approx \langle T_{\text{coh}} \rangle \gg KT$.

4) The energy loss of moving electron (accelerated by laser field \mathbf{E}_0) on each spatial period of its oscillation

$$\Delta E = \oint \{dT(v(x)) / dx\} \approx (\pi e^3 n_e / E_0) \left| \ln \left\{ 1 - (eZ^{2/3} m \Omega / 16 E_0 \hbar)^2 \right\} \right| \ll 1 \text{ keV}$$

is small ($\langle T_{\text{coh}} \rangle \gg \Delta E$). The motion of electrons remains quasi-harmonic during $N \approx \Omega \Delta t \approx 10^3$ oscillations.

These fast subrelativistic oscillating electrons interact with Mössbauer-type nuclei which are non-excited in their initial state. The low energy transitions in nuclei are known to be the result, in most cases, of single-nucleon processes. Assuming r to be the radius of a proton related to the Mössbauer transition, one can easily deduce an expression for the non-stationary energy of the interaction of a moving electron with a nucleus $V(\mathbf{r}, t) = -Ze^2 \exp(-R/R_0) / |\mathbf{R} - \mathbf{r}|$, where R_0 is the parameter of electronic shielding, $\mathbf{R} = \{\mathbf{v}t, \rho, 0\}$. The above interaction can induce excitation of the nucleus. The probability of the excitation can be calculated according to equation

$$P_{sk} = n^* \iint W_{sk}(\rho, v) f(v) v 2\pi \rho d\rho dv, \quad W_{sk} = \hbar^{-2} \left| \int_{-\infty}^{\infty} V_{sk}(t) \exp(i\omega_{sk}t) dt \right|^2$$

Here $f(v) = [1 - (v/v_{\text{max}})^2]^{1/2} / \pi v_{\text{max}}$ is the velocity distribution function for periodically moving electron.

The motion of the fast electrons can be approximated by the laws of classical kinetics.

Expanding now the expression for $V(\mathbf{r}, t)$ into a series of the parameter $r/(\rho^2 + v^2 t^2)^{1/2}$ and calculating the matrix elements of the operator of the nucleon coordinate, after averaging by v and targeting distances ρ one can derive the result for the total probability of direct excitation of the nucleus.

The corresponding total probability of Coulomb excitation of nuclei (or the excitation of the atomic electron to the upper X-level) in the dipole approximation equals:

$$P_{sk} \approx [3Z^2 e^2 n^* c^3 / 2\hbar \omega_{sk}^3 \tau (1 + \alpha_0)] (m / \hbar \omega_{sk})^{1/2} \ln[eE_0 / \Omega (m^3 / \hbar \omega_{sk})^{1/2}] FG_{\tau}$$

Here $G_{\tau} = \Delta t / \tau$ for the case $\tau \geq \Delta t$ and $G_{\tau} = 1$ for the case $\tau \leq \Delta t$, τ — the lifetime of the excited nucleus (electron) state E_k for the dipole transition $E_s \rightarrow E_k$ with excitation frequency $\omega_{sk} \leq \langle T_{\text{coh}} \rangle / \hbar$.

For octupole transitions:

$$P_{sk} \approx 9 Z^2 e^2 n^* c^7 m^4 (eE_0 \Omega / m)^3 / 28\pi \tau \hbar^7 FG_{\tau}$$

The probability of Coulomb excitation of nuclei by laser produced subrelativistic oscillating electrons during the action of a short powerful polarized optical laser pulse on a perfectly oriented crystal exceeds the probability of Coulomb excitation by thermalized electrons (at the same laser power $W/\Delta t$) by the coefficient:

$$C \approx (KT / \hbar \omega_{sk})^{1/2} \exp(\hbar \omega_{sk} / KT),$$

which equals several orders of magnitude for the case $\hbar \omega_{sk} \gg KT$. As a result, the probability of Coulomb excitation of lattice nuclei reaches 50%.

Such nonthermal mechanism of producing excited nuclei (or atomic electron) states proves to be by many orders more effective than the traditional methods of thermal- or photo- (by equilibrium X-rays) excitation (at $\Delta t \gg \delta t_1$) of nuclear or atomic levels for gamma-laser (or X-laser) in quasi-equilibrium laser electron or ion plasma.

NUCLEAR TRANSITION EXCITATION IN HIGH-TEMPERATURE NEAR-SURFACE PLASMA: FEASIBILITY OF GAMMA-LASING

A. V. Andreev, V. M. Gordienko, A. B. Savel'ev

Physics Department and International Laser Center of Moscow State University,
119899, Vorobyevy gory, Moscow, Russia
e-mail: andreev@sr.phys.msu.su

The problem of nuclear transitions excitation and stimulated nuclear reactions in matter under extreme conditions is of much interest for nuclear and laser physics, astrophysics, as well as for some technical applications. One of the recently designed approach to achieve such a state of matter is to heat rapidly a thin surface layer by an ultrashort laser pulse with duration of 1 ps or less and intensity exceeding 10^{15} W/cm². This near-surface plasma layer consists of highly-ionized atoms with solid-state density, whereas the electron temperature exceeds 1 keV. Hence it emits intense ultrashort X-ray pulses, ultra-relativistic electrons and fast ions which can be used for nuclear transitions and reactions stimulation.

In this paper we discuss the feasibility of observing low-lying nuclear transitions excitation by X-ray plasma emission and plasma electrons under interaction of ultrashort laser pulses of moderate intensity of 10^{15} - 10^{17} W/cm² with solid targets. Possible choice of isomers is tabulated. The estimations as well as experimental arrangement for the case of the Hg-201 stable isomer (abundance in natural Hg 13%) with the lowest level at 1.556 keV (1/2-) are presented. For 10 mJ, 500 fs laser pulse with intensity $\sim 10^{15}$ W/cm², the number of excited nuclei exceeds $\sim 10^7$. The detection can be made using both delayed γ -emission and conversion electrons.

In the final part of the paper estimations for population inversion and γ -lasing on metastable isomers are discussed following considerations in [1, 2]. Here, a four level scheme was introduced. The nuclei in isomeric state (level energy higher than 50 keV) are excited by an ultrashort burst of plasma X-rays to the near-lying level (separated by a few hundreds eV) with short lifetime of 10^{-10} s. Population inversion is achieved with respect to the third level with lifetime of 10^{-12} s, the depopulation of which to the ground state preserves the inversion. The γ -quanta energies are of 1-100 keV. The possible choice of isomers with the desired level structure is tabulated as well. The usage of an ultrashort laser pulse created plasma promises significant advantages for the realization of the proposed scheme, this being the last subject of the paper.

This work is supported by grant 97-02-17013 from Russian Fund for Basic Research.

1. A. V. Andreev, Vestnik MGU, ser.3, Physica i Astronomiya 35 (3), 28 (1994)
2. A. V. Andreev, V. M. Gordienko, A. B. Savel'ev, preprint of the Physics Department, Moscow State University, #1, 1997, 12 p.

ON THE POSSIBILITY OF GAMMA-LASER PUMPING OCCURING AT A CHARGED PARTICLES COUNTER MOTION AND DENSITY-MODULATED ELECTRON BEAMS BY A SUPER-RIGID INTENSIVE RADIATION

Maksyuta N.V.

Kiev Shevchenko University, Radiophysical Dept., 252033, Kiev, Ukraine

Abstract. It is shown in the paper that an intensive short-wave radiation occurs at the relativistic charged particle counter motion towards a density-modulated electron beam. It may be used for the system of coherent gamma-laser pumping and coherent gamma-optics problems.

A problem on a motion and radiation of a relativistic electron in a field of a counter plane relativistic density-modulated electron beam is considered in the paper. First it is necessary to define an electric field created by this beam. Let the beam be in a moving coordinate system K' . The system K' moves with respect to a laboratory coordinate system K parallel to the axis z ; axis x and y are parallel to x' and y' . As follows from [1] the electric field of a separate electron in the point x'_0, y'_0, z'_0 in the system K' equals

$$\vec{E} = -\frac{e\vec{R}\gamma_1}{R^*{}^3}, \quad (1)$$

where $\vec{R} = \{x - x_0, y - y_0, z - z_0\}$ is a radius-vector of a charged particle in the observation point x, y, z , $R^*{}^2 = (x - x_0)^2 + (y - y_0)^2 + (z - z_0)^2\gamma_1$, γ_1 - a Lorentz-factor of a modulated beam. Besides the law of electron beam modulation in the system K may be described by the expression

$$n(z_0, t) = n_0\gamma_1 \{1 + \Delta \cos[k\gamma_1(z_0 - ct)]\}, \quad (2)$$

where $k = 2\pi/\Lambda$, Λ - a beam modulation period in the system K' , n_0 - an average concentration of particles in a beam. The electric field of a plane modulated electron beam of thickness d is defined by the correlation

$$\vec{E}(x, z, t) = \int_{-\infty}^{\infty} dz_0 \int_{-\infty}^{\infty} dy_0 \int_{-d/2}^{d/2} \vec{E}n(z_0, t) dx_0 \quad (3)$$

From (1) ÷ (3) we find

$$\begin{aligned} \mathcal{E}_x(x, z, t) &= -4\pi en_0\gamma_1 \left\{ \chi \left(\frac{d}{2} - |x| \right) \left[x + \frac{\Delta}{k} \cos[k\gamma_1(z - ct)] \exp\left(-k \frac{d}{2}\right) \text{sh}(kx) \right] + \right. \\ &\quad \left. + \sin g(x) \chi \left(|x| - \frac{d}{2} \right) \left[\frac{d}{2} + \frac{\Delta}{k} \text{sh}\left(k \frac{d}{2}\right) \cos[k\gamma_1(z - ct)] \exp[-kx \cdot \text{sing}(x)] \right] \right\}, \quad (4) \\ \mathcal{E}_z(x, z, t) &= 2en_0\Lambda \Delta \sin[k\gamma_1(z - ct)] \left\{ \exp\left(-k \frac{d}{2}\right) \text{sh}(kx) \chi \left(\frac{d}{2} - |x| \right) + \sin g(x) \cdot \right. \\ &\quad \left. \chi \left(|x| - \frac{d}{2} \right) \text{sh}\left(k \frac{d}{2}\right) \exp[-kx \cdot \text{sing}(x)] \right\}. \end{aligned}$$

Here $\chi(x)$ is Heaviside unit step function. Let's consider now a following model. Let a relativistic electron moves opposite to a modulated beam along its surface at a distance $x_0 \geq d/2$. Its motion is described by a following equation system:

$$\begin{aligned} \gamma_2 \ddot{x} + \frac{\dot{x}\dot{z}}{c^2} \gamma_2^3 &= \frac{2\pi e^2 \gamma_1 n_0 d}{\mu} + \frac{eE_0 \gamma_1}{\mu} \cos[k\gamma_1(z-ct)] \exp(-kx_0), \\ \gamma_2^3 \ddot{z} &= -\frac{eE_0}{\mu} \sin[k\gamma_1(z-ct)] \exp(-kx_0), \end{aligned} \quad (5)$$

where $E_0 = 2en_0 \Delta \text{sh}(kd/2)$. Accounting that a longitudinal field component \mathcal{E}_z is γ_1 times less of a transverse one \mathcal{E}_x (see (4)) and using the initial conditions $z(0) = 0, \dot{z}(0) = -c, x(0) = x_0, \dot{x}(0) = 0$ the solution (5) is represented in the form:

$$\vec{r}(t) \approx \vec{i} \left\{ x_0 + \xi t^2 + \zeta \sin^2 \Omega t \right\} - \vec{k} ct, \quad \xi = \frac{\pi e^2 \gamma_1 n_0 d}{\mu \gamma_2}, \quad \zeta = \frac{eE_0 \exp(-kx_0)}{2\gamma_1 \gamma_2 \mu k^2 c^2}, \quad \Omega = 2k\gamma_1 c \quad (6)$$

Originating from (6) and basing on the results of the paper [2] a total number of quanta radiating from a unit of a path flight is defined by:

$$N = \sum_{m=1}^{\infty} N_m = \frac{e^2}{\hbar c^2} \Omega \sum_{m=1}^{\infty} S_m, \quad S_m = \sum_{n=0}^{\infty} \frac{(-1)^n m(2m+2n)! (m\Omega \gamma_2 \zeta / 2c)^{2m+2n}}{2^{2m+2n-2} n! [(m+n)!]^2 (2m+n)! [4(m+n)-1]}. \quad (7)$$

All N_m quanta in each harmonic are distributed in a frequency region $m\Omega/2 \leq \omega \leq 2m\Omega\gamma_2^2$ and

have maximum at $\omega_{m,\max} = m\Omega\gamma_2^2$. If select a regime at which $\gamma_1 = \gamma_2 = \gamma$, then $\omega_{m,\max} = 4\pi c \gamma^3 m / \Lambda$. At $m = 1$, for example, for the parameters $\gamma \approx 5 \cdot 10^2$, $\Lambda \approx 10$ cm, $d \approx 1$ cm, $z_0 \approx$ cm, $n_0 \approx 10^{10}$ cm⁻³, $\Delta \approx 0.5$ a number of quanta radiated in the vicinity of the frequency $\omega_{m,\max} \approx 5 \cdot 10^{18}$ c⁻¹ from one meter of flight according to the formula (7) is equal $N_1 \approx 2$. Such type of nondecay sources may be utilized for gamma-laser pumping. So, for example, at electron beam current of 1A a number of quanta getting in the ranges of characteristic line width of the generation $\Gamma \approx 10^9 \div 10^{12}$ c⁻¹ equals $\sim 10^{10} \div 10^{13}$.

Note that such a moving modulated electron beam may be considered a dynamic microindulator. There is one more important moment in this system along with Λ reduction in γ_1 times, i.e. a guiding electric field in a transverse direction changes according to the law of $\exp(-kx)$ whereas in alternative static microindulator this change would be defined by a dependence $\exp(-kx\gamma_1)$. It means that a charged particle interaction with a dynamic microindulator will be effective in a broad range of distance, i.e. to get an intensive short-wave radiation one may use a charged particles beam with a rather great transverse cross-sections that leads to a sharp increase of radiation intensity.

Note in conclusion that an analogous consideration can be done in the case of charged particles counter motion with a system of periodically alternating electron bunches. One may look far to calculate an originating intensive short-wave radiation at a counter motion of one bunch system in respect to the other.

References

1. L.D.Landau, Ye.M.Lifshits, Theory of the field.- Moskva: Nauka, (1988).
2. N.A.Korkhmazian, Izv. Academy of Science ArmSSR, Physica, (1970), №5, p.287.

PHYSICS WITH THE $^{178\text{m}2}\text{Hf}$ HIGH-SPIN ISOMER**Ch. Briançon**

Institut National de Physique Nucléaire et de Physique des Particules

Centre de Spectrométrie Nucléaire et de Spectrométrie de Masse

Bâtiment 104-108, 91405 Orsay Campus, France

This talk will discuss nuclear properties of the isomer from collinear laser spectroscopy and experiments on isomer deexcitation induced by charged particles.

MEASUREMENT OF THE ISOMERIC-TO-GROUND STATE RATIO

IN THE REACTION $^{180}\text{Ta}^m(\gamma,\gamma^c)^{180}\text{Ta}^{g(m)}$

S. A. Karamian¹, C. B. Collins², J. J. Carroll³, J. Adam¹

¹ Joint Institute for Nuclear Research, 141980 Dubna, Russia

² University of Texas at Dallas, 75080 Richardson, USA

³ Youngstown State University, 44555 Ohio, USA

The only isomer abundant in nature, $^{180}\text{Ta}^m$, can be used in studies significant for nuclear- and astro- physics, as well as for the γ -ray laser development. Depletion of the isomer in the (γ,γ^c) reaction was observed with a relatively high yield in ref. [1] as the bremsstrahlung end-point energies E_e varied from 2.5 to 5.0 MeV. In present work the $^{180}\text{Ta}^m$ isomer depletion in the (γ,γ^c) reaction was studied at the E_e values of 6.0 - 7.6 MeV with absolutization of the reaction yield by the monitoring reaction $^{232}\text{Th}(\gamma,f)$. The excitation function of the latter reaction is known with high accuracy. Thus, comparison of the activity yields produced in both reactions in identical geometry allows one to determine the isomeric-to-ground state ratio in an absolute manner.

As long as the ^{nat}Ta target was used, the reaction on the abundant isotope ^{181}Ta could create some background. Since the neutron binding energy of ^{181}Ta is equal to $B_n = 7.58$ MeV, the contribution of the $^{181}\text{Ta}(\gamma,n)^{180}\text{Ta}^g$ reaction is negligible at $E_e \leq 7.6$ MeV. The detection of the $^{180}\text{Ta}^g$ yield must be attributed to the reaction $^{180}\text{Ta}^m(\gamma,\gamma^c)$, despite a very low $^{180}\text{Ta}^m$ concentration of $1.2 \cdot 10^{-4}$. For the cross-section analysis it is important to mention that the latter reaction is a dominating mode of the compound nucleus deexcitation below the threshold of neutron emission. The value $B_n = 6.6$ MeV is deduced for $^{180}\text{Ta}^m$ from nuclear mass quantities. However, due to the spin conservation requirement one has to add the yrast energy of about 0.5 MeV. Therefore, the (γ,n) reaction can be competitive with the (γ,γ^c) process only at $E_\gamma \geq 7.3$ MeV. Quite a few γ -quanta with such energy are created at $E_e = 7.6$ MeV. Due to these reasons the $^{180}\text{Ta}^m$ depletion is studied at $E_e \leq 7.6$ MeV.

The measurements were performed using the MT-25 microtron beam at Dubna. The stack of ^{nat}Ta and ThO_2 targets was placed behind the W electron beam converter for activation by the bremsstrahlung radiation. The gamma-spectra of radioactive nuclides induced in the targets were measured by a HP Ge-detector with the energy resolution of 1.8 keV by the ^{60}Co lines.

A rich γ -spectrum of fission fragments was recorded in the case of ThO_2 target. X-ray and γ -ray lines of the $^{180}\text{Ta}^g$ decay ($T_{1/2} = 8.15$ h) were detected after the Ta activation and their intensities were measured with good statistics. The correct ratio of the line areas and their lifetimes make sure that pure $^{180}\text{Ta}^g$ is detected without any contaminating background. From the γ -line intensities, taking into account the decay and efficiency factors, one can evaluate the relative yield of the reaction normalized to one target nucleus and one electron accepted into the converter. The energy dependence of the $^{180}\text{Ta}^m (\gamma, \gamma') ^{180}\text{Ta}^g$ reaction yield in a wide interval of E_e from 2.5 to 7.6 MeV was plotted after combination of the present measurements and previous ones [1]. The yield simulation procedure is described schematically below. The integrated yield was reproduced by the equation:

$$Y(E_e) = c \int_0^{E_e} \sigma_R(E_\gamma) N_\gamma(E_\gamma) dE_\gamma, \quad (1)$$

where $\sigma_R(E_\gamma)$ is the reaction excitation function and $N_\gamma(E_\gamma)$ is the spectral distribution of the bremsstrahlung radiation normalized to one electron. The latter function was calculated by the EGS4 Monte-Carlo code. The coefficient c was determined from the Th fission yield. The cross-section of the $^{180}\text{Ta}^m$ depletion was introduced as a product of the photon absorption cross-section and the ground-state feeding factor:

$$\sigma(^{180}\text{Ta}^g) = \sigma_{GDR}(E_\gamma) \cdot \sigma_g / (\sigma_g + \sigma_m), \quad (2)$$

where the parameters of giant dipole resonance were taken from ref. [2] for the ^{181}Ta nucleus. The ground state to total cross-section ratio and the excitation function of the $^{180}\text{Ta}^m$ depletion were deduced finally after numerical simulations using eqs. (1) and (2). This information is important for the astrophysical calculation of the $^{180}\text{Ta}^m$ lifetime in the stellar electromagnetic radiation bath.

1. C. B. Collins *et al.*, Phys. Rev. **C42** (1990) R1813
2. S. S. Dietrich and B. L. Berman, At. Data Nucl. Data Tables **38** (1988) 199

ON THE POSSIBILITY TO MEASURE THE CROSS-SECTIONS OF NUCLEAR GAMMA-TRANSITIONS, EXCITED BY X-RAY TUBE RADIATION

I. M. Israilev, V. Yu. Politov

Federal Nuclear Centre - ALL-Russian Institute of Technical Physics,
Snezhinsk P.O. BOX 245, RUSSIA
e-mail: vup@nine.ch70.chel.su

Abstract. An experiment on investigation of the process of nuclear levels photoexcitation by X-ray tube radiation is proposed. Two experimental setups are planned. In one of them the nuclei will be pumped by the continuum part of the X-ray spectrum, and in the other - by the resonance K_{α} or K_{β} lines of suitable anode materials. Gamma-quanta resulting from the excitation cascade will be measured by a semiconductor multi-channel spectrometer. The estimations of noise and the yield of the needed quanta are presented as well.

Experiments for the investigation of the spectroscopic characteristics of excited nuclear levels are stimulated by the problem of gamma-laser elaboration. One of the most promising ways for such investigations is the photopumping of nuclei by X-ray radiation, originated in X-ray tubes [1] or electron accelerators [2, 3].

In this paper the pumping of some nuclei by using the X-ray tube radiation is proposed. The main information about the nuclear structure will be extracted from the spectra of the γ -quanta cascade, resulting from the decay of excited levels, which are planned to be measured by a semiconductor multi-channel spectrometer. First of all, we are interested in the γ -transitions cross-sections.

Two variants of excitation are considered: by the resonance K_{α} or K_{β} lines of the tube's anode substance, or by the continuum part of the X-ray spectrum. Realization of resonance pumping requires that one of the anode lines coincides within the range of one or two half-widths with some γ -transition of the irradiated nucleus. Certainly, such coincidences are very seldom, but the degree of lines overlapping may be improved using the technique of pumping quanta Compton softening (if their energies slightly exceed the one of the γ -transition).

For the experiments beginning we have selected so far two resonance pairs - nuclei Pu^{239} , Hg^{201} - having γ -levels with energies 75.753 keV, 32.17 keV and anode substances Pt, Ba, producing the lines $K_{\beta 1}$ (75.748 keV), $K_{\alpha 1}$ (32.194 keV), respectively. Besides, for a series of nuclei with rather low-lying excited levels (excitation energies ≤ 100 keV), the pumping by purely continuum radiation will be attempted. Most interesting nuclear structures are typical for stable isotopes Os^{187} , Dy^{161} , Yb^{171} , Rh^{103} .

Numerical estimations for the effect to be measured give 1-50 cascade γ -quanta per minute. They were performed for parameters for elaborated static X-ray tube with a voltage of 100 kV and a current of dozens of milliamperes. The design of the tube assumes the possibility to change anodes that enables to select the optimum irradiating substance for a given nucleus.

1. E. J. Seppi, F. Boehm, *Nuclear resonance excitation using a diffraction monochromator*, Phys. Rev. **128**, N5 (1962)
2. J. J. Carroll *et al.*, *Absolute measurement of spatial and spectral characteristics of bremsstrahlung using the photoexcitation of nuclear isomers*, Rev. Sci. Instrum. **64**, N8 (1993)
3. J. J. Carroll *et al.*, *Photoexcitation of nuclear isomers by (γ ; γ') reactions*, Phys. Rev. C **43**, N3, (1991)

PHOTONUCLEAR REACTIONS ON HIGH-SPIN ISOMERIC TARGETS

A.P. Tonchev, Yu.P. Gangrsky, A.G. Belov, A.F. Novgorodov

JINR, Dubna 141980, Moscow region, Russia

Abstract. Production of the new pure high-purity spin isomeric states is discussed. The most promising for the investigations isomers are selected. The first results of the deexcitation of ^{108}Ag ($J^\pi=6^-$) and ^{166}Ho ($J^\pi=7^-$) are presented.

The predominant number of experiments with bremsstrahlung γ -rays have been carried out as a rule on stable isotopes which have low ground state spin. Therefore, in Photonuclear reactions states are excited with spin values close to the ground state spin. The excitation mechanism of this Photonuclear reactions is known very well for most isotopes in the region of the Giant Dipole Resonance and these experimental results are summarized in the survey [1].

At present only two stable isotopes, $^{180}\text{Ta}^m$ ($J^\pi=9^-$) [2] and $^{176}\text{Lu}^m$ ($J^\pi=7^-$), are available as high-spin targets. Recently this kind of experiments were performed also on the more exotic, four-quasi particle $^{178}\text{Hf}^{m2}$ isomeric target [3].

It is very interesting to extend this investigation on other high-spin isomers. The large deexcitation cross-section of these states in inelastic gamma-quanta scattering allows to hope for a successful measurement on a small number of atoms (less than 10^{15}) in experiments with isomeric targets. The interest in nuclear reactions with high-spin isomers has been enhanced by the theoretical consideration of the K-mixing in excited nuclei and by the possibility for an efficient pumping process in the γ -laser problem. In Table possible candidates for high-spin isomeric targets [4] are presented.

Accumulation of these nuclei can be done on a power reactor. The enough cooling time allows the ground state of these isomers to completely decay, due to the short time of life. This kind of accumulation methods is very effective if one takes into account the big integral cross section for neutron capture. The necessary amount of radioactive nuclei can be produced using milligrams of initial samples. Separation of the isomers from the initial stable nuclide may be done on a mass-separator. That essentially improves the experimental background conditions and allows to obtain a target only with isomeric nuclei. In the case of the $^{178}\text{Hf}^{m2}$ isomer the lifetime of whose low-lying

Table. Ground and isomeric characteristics of some nuclei which may be used as isomeric targets

Nuclear states	Energy keV	J^π \hbar	ΔJ^π	$T_{1/2}$	B_n MeV
^{108}Ag m	109.5	6^+	5	418.25 y	7.27
g	0	1^+		142.2 s	
^{166}Ho m	5.0	7^-	7	1200 y	6.24
g	0	0^+		26.8 h	
^{178}Hf m2	2450.0	16^+	8	31 y	7.62
m1	1147.4	8^-		4 s	
^{180}Ta m	73.3	9^-	8	$1.2 \cdot 10^{13}$ y	6.55
g	0	1^+		8.1 h	
^{186}Re m	150.0	8^+	7	$2 \cdot 10^5$ y	6.18
g	0	1^-		90.6 h	
^{242}Am m	48.6	5^-	4	152 y	5.54
g	0	1^-		16.01 h	

state ($J^\pi=8^-$) is only 4 seconds, a pneumotransport device may be used. For the other cases the standard procedure of excitation and measurement is possible. Using an activation technique in this case is preferable compared to the in-beam measurement because of the small amount of irradiated isomeric target and the absence of background contribution due to the backing material.

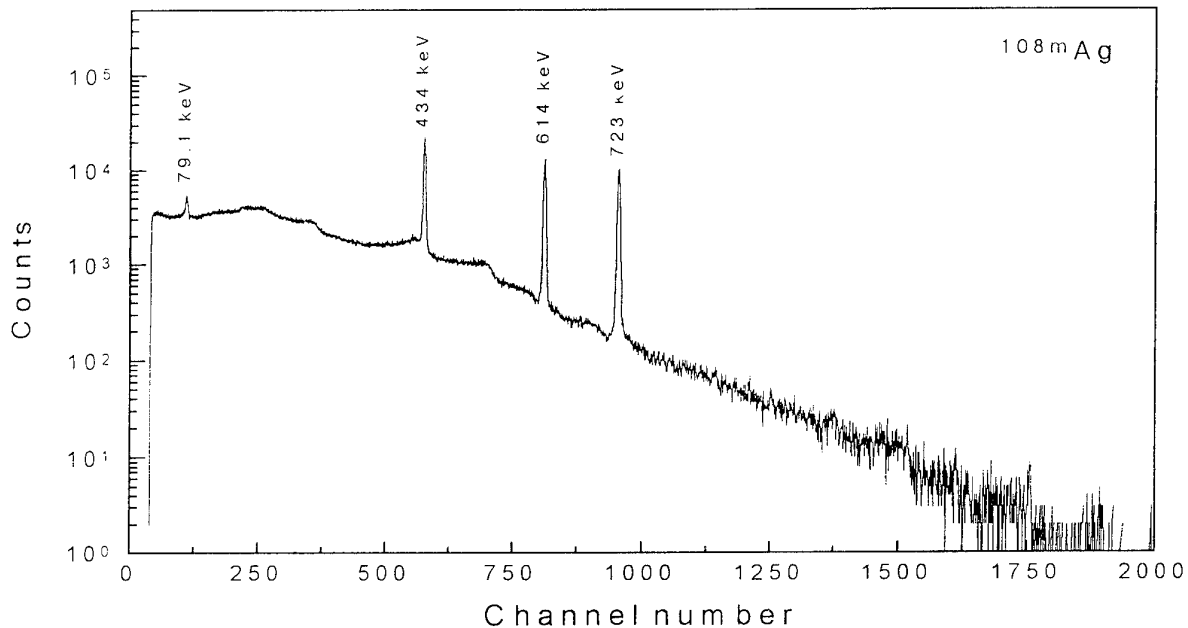

Fig. Spectrum of ^{108m}Ag γ -rays following neutron excitation of $^{\text{nat}}\text{Ag}$. Cooling time is more than 13 years. Number of nuclei in the ^{108m}Ag isomeric state with $J^\pi = 6^+$ is 10^{17} .

In the figure the γ -spectrum of isomeric the target ^{108m}Ag ($J^\pi = 6^+$) obtained after (n,γ) reactions is shown. The ground state of this nucleus is short-lived (2.41 m) and, after some time, it completely disintegrates. Similar is the situation with the activity induced by the $(n,2n)$, (n,p) and (n,α) reactions. This activity is short-lived and soon completely disintegrates too.

It is possible to get a pure isomeric sample after mass separation. That means the ballast activity and the target elements will be eliminated after this procedure. At present mass separation is being performed for one of these targets (^{166}Ho).

1. Yu. P. Gangrsky, A. P. Tonchev, N. P. Balabanov, *Phys. Part. Nucl.* **27**, 428 (1996)
2. C. B. Collins, J. J. Carroll, T. W. Sinor, M. J. Byrd, D. G. Richmond and K. N. Taylor, *Phys. Rev. C* **42** (5), 1813 (1990)
3. Yu. Ts. Oganessian et al., *J. Phys. G: Nucl. Part. Phys.* **18**, 393 (1992)
4. A. G. Belov, Yu. P. Gangrsky, A. P. Tonchev, *Hyperfine Interactions* (in press)
JINR preprint E-15-95-396, Dubna, 1995

PROGRESS IN THE RESEARCH PROGRAM ON ADVANCED PHOTON SCIENCE**Takashi Arisawa**

Japan Atomic Energy Research Institute, Kansai Research Establishment

Nihon Seimei Bldg. 4F, 608-9 Higashi Shiokoji-cho, Shimogyo-ku, Kyoto, 600 JAPAN

e-mail: arisawa@apr.jaeri.go.jp

Among the development of Advanced Photon Sources, ultra short pulse/ultra high peak power photon sources with 9.6 TW at 16.6 fs pulse width were developed and will be extended to 100 TW region this year. This will promote X-ray laser experiments especially on the recombination type inversion system using gas mixture. Expecting a compact high peak power laser system at high repetition rate, diode laser pumped solid state lasers have been developed, and 10^5 W were achieved in green wavelength. High quality electron beam source development is also under way to get low emittance, high spatial/temporal contrast which leads to gamma ray generation using inverse Compton or coherent ultra short wave generation with micro bunching or prebunching techniques. The LINAC section of the SPring8 is to be used for this purpose.

With photons using energies up to 10 MeV, high spin exotic deformation, new vibrational mode and nuclear isomer spectroscopy studies will be made. For the applications of light sources from EUV to X-ray, dynamic imaging, inner shell selective reaction and quantum control is studied. For the application of gamma-ray, induced gamma-ray emission, ultra high sensitivity 2D matrix analysis on NDA basis, selective nuclear fission and nuclear transmutation will be studied. As an application to the photonuclear reaction, nuclear isomer excitation, up-conversion type gamma-ray emission, collective nuclear emission and optical nuclear fission spectroscopy will be made.

FILAMENTARY X-RAY SOURCE BY "CRUISE EFFECT"

M. Ganciu, C. B. Collins , M. C. Penache, D. Penache, V. Zoran* and I-Iovitz Popescu**

Institute of Atomic Physics, N.I.L.P.R.P., P.O. Box MG-36, R-76900 Bucharest, Romania

*Institute of Atomic Physics, I.P.N.E.-H.H., P.O. Box MG-6, R-76900 Bucharest, Romania

**University of Texas at Dallas, Center for Quantum Electronics, P.O. Box 830688, Richardson,
TX 75083-0688, USA

Abstract: The Cruise Effect (electron beam captured and guided by a dielectric surface) was verified for several types of dielectric materials, such as ferrite, silicon oil and lithium niobate. Under proper preionization conditions, a few centimeters long filamentary discharge has been stabilized along a cylinder or a plane ferrite surface. The X-rays emission associated with this discharge has an intensity comparable to that generated by the electron beam totally stopped in a stainless steel anode.

Depletion of certain K-quantum number nuclear isomers such as ^{178}Hf may be achieved by up-conversion with relatively "soft" photons, having an energy of the order of tens to hundreds keV [1]. In this case the use of less expensive, tunable, lightweight X-ray machines becomes possible.

Recently, an X-ray generator providing an optimum coupling of the radiation to the active medium has been proposed. The X-rays are produced by bremsstrahlung of a pulsed, high power density electron beam [2] cruising along the surface of a dielectric fiber [3] in a so called "inverse capillary discharge"[4].

Together with the dependence on the pressure, voltage and geometrical configuration of the discharge, the X-ray emission by Cruise Effect (CE) is currently investigated as a function of the dielectric material, and of its geometry and size. A few preliminary results will be presented in this report. The X-rays were recorded by a collimated NE102A plastic scintillator, mounted outside the discharge tube, coupled via an optical fiber to a fast photomultiplier and an Tektronix TDS350 oscilloscope. Previous observations have been confirmed, namely: the X-ray emission, is associated with the electron beam "dressing" the dielectric fiber and the appearance of "hot points" on its surface, and the amplitude and the duration of the X-ray pulse do not depend on the discharge repetition rate in the investigated range (up to 100 Hz).

Several types of ferrite, as well as silicon oil and lithium niobate have been studied. It has been found that the degree of "cruising" of the electron beam depends on the ferrite composition. Besides the common cylindrical geometry using thin dielectric fibers, a quasi-planar geometry has been achieved using a low conductivity ferrite cylinder of 4 mm diameter parallel to the discharge tube axis. Under proper preionization conditions, a 2 cm long filamentary discharge stabilized along the cylinder surface, associated with X-ray emission. Since no damage of the ferrite surface has been observed, apparently CE provides a mechanism of X-ray generation different of that proposed in [5], a mechanism in which the preionization of the gas adjacent to the dielectric surface plays a critical role for the "cruising" effect. Indeed, we observed the CE on dielectrics of various shapes and sizes, including submillimetric ferrite particles, and also with various geometries of the discharge; in all cases the preionization of the discharge gas was a necessary condition.

The amplitude of the X-ray pulse emitted by CE along 2 cm of ferrite has been found only about 10% less than that of the X-rays emitted by the discharge electron beam totally stopped in a stainless steel anode at 45° relative to the beam axis. This comparison proves that X-rays are also effectively generated by fast electrons in glancing interactions along the dielectric surface, however with smaller absorption losses.

We anticipate that, provided a proper plasma is generated on the cruising surface, the CE would work also for relativistic electrons. This hopefully would pave the way towards filamentary hard X-ray pumping sources strongly coupled with the irradiated active media, as requested for induced gamma emission.

- [1] C. B. Collins, J. J. Carroll, *Hyperf. Inter.* (1996, in print)
- [2] M. Ganciu, I.-Iovitz Popescu, V. Zoran, A. M. Pointu, *Nucl. Instr. and Methods in Phys. Res.* **B98**, 541 (1995)
- [3] M. Ganciu, E. Dewald, M. Nistor, D. Penache, I.-Iovitz Popescu, V. Zoran, *Rom. J. Phys.* **39**, 787 (1994)
- [4] V. I. Zoran, M. Ganciu, A. M. Pointu, C. B. Collins, I.-Iovitz Popescu *Hyperf. Inter.* (1996, in print)
- [5] K. Watanabe, K. Furusho, S. Kashiwabara and R. Fujimoto, *J. Appl. Phys.* **68**, 5059 (1990)

INTENSE ELECTRON BEAMS IN OPEN ENDED HOLLOW CATHODE TRANSIENT DISCHARGES FOR TABLE TOP X-RAY SOURCES

N. Mandache, M. Nistor, I.-Iovitz Popescu and S. Udrea**

Institute of Atomic Physics, N.I.L.P.R.P., Bucharest-Magurele, Romania

M. Ganciu*, G. Modreanu and A. M. Pointu

Université Paris-Sud, LPGP, Orsay, France

E. Dewald*, K. Frank and D. H. H. Hoffmann

Physics Department, University of Erlangen-Nürnberg, Germany

*Permanent address: Institute of Atomic Physics, N.I.L.P.R.P., Bucharest-Magurele, Romania

**Permanent address: Institute of Atomic Physics, I.P.N.E.-H.H., Bucharest-Magurele, Romania

Abstract: In an open ended hollow cathode transient discharge, preionization controlled, an intense electron beam of high reproducibility, from shot to shot, and high spatial stability was produced. The measurements of the X-ray emission from the electron beam interaction with a thin Al foil proved the possibility to use such devices as table-top intense point-like X-ray sources strong coupled with small quantities of materials to be irradiated.

The production of pulsed intense electron beams in table top devices is important for the development of compact intense X-ray sources. Perhaps one of the most dynamic development in this direction was achieved by using high voltage transient discharges in gases. Since the electron generation, electron acceleration and self-focused beam propagation are intimately correlated in the frame of a common mechanism, these devices are very compact.

The pseudospark [1], the channel-spark [2] and more recently, the preionization controlled open ended hollow cathode configuration (PCOHC) transient discharge device [3] are the most advanced among such devices. The typical parameters of the electron beams produced in these devices are: beam current of 100 A - 1 kA, beam duration of 10 - 100 ns, electron energy in the range of a few keV to the energy corresponding to the maximum applied voltage (10 - 30 kV), beam diameter of about 1 mm, power density of $10^8 - 10^9$ W/cm² and repetition rate of tens of Hz.

In a PCOHC with multielectrode geometry (Fig. 1) we realized the beam parameters obtained in the pseudospark under similar conditions of input energy, gas pressure and diameter of the bore holes [4, 5]. In this device the main high voltage discharge takes place between an open ended hollow cathode 30 mm in diameter, and a plane anode. In the multielectrode configuration, there are in addition five plane electrodes each 2 mm thick, with 2 mm central bore holes, separated by disk shaped insulators each 3 mm thick, with 10 mm bore holes. The first 4 electrodes from the cathode are floating and the last one is connected to the external capacitor (0.5 - 2 nF), playing role of anode. A spark-gap in the selfbreakdown mode was used to close the main discharge circuit. In most experiments the working gas was air at a pressure in the range 0.05 - 0.3 torr. For a given pressure and geometry there is an optimum preionization current that matches the electron beam parameters. The geometry and implicitly the self capacitance of the electrode configuration have a direct and important influence on the fast electron beam current.

The PCOHC, which has an open ended hollow cathode, can be also used with a dielectric cathode [3]. In this case the later phases of the discharge, which appear after the electron beam phase, are strongly suppressed. That means a longer life time for the cathode which is not

damaged by the high currents concentrated in small spots characteristic to the later phases of the discharge.

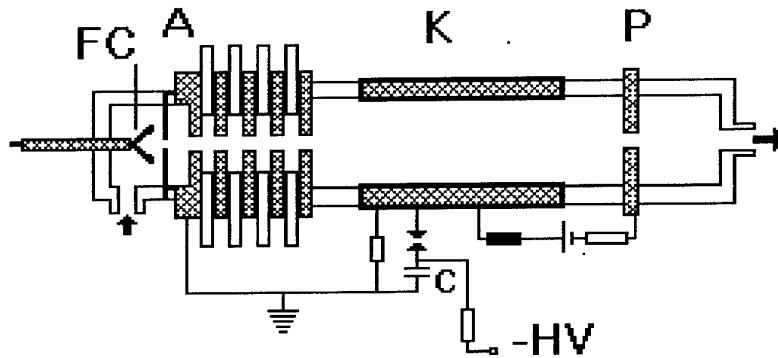

Fig. 1. PCOHC geometry with multielectrode configuration, electrical circuit and device for beam current measurements

FC - Faraday cup; A - anode; K - open ended hollow cathode; P - preionization electrode; C - external capacitor; HV - high voltage supply

The geometry of the cathode and the presence of the small current (a few mA) preionization discharge, which assures a constant presence of charge carriers for the main discharge (400-800 A), determine a high reproducibility in electron beam parameters from one shot to another. Apart from the measurements made with the Faraday cup, the most reliable measurements on the reproducibility of the high energy electron beam were realized by recording the X-ray emission from the interaction of the electron beam with a thin Al foil (25 μm). The X-ray pulses were recorded with a fast scintillator-PM system; the peak values were reproducible within 20% and the FWHM within less than 5%.

The X-ray source diameter (i.e. the diameter of the high energy electron beam) was estimated from X-ray pinhole measurements. The pinhole was made of Pb and had a 0.1 mm diameter. Due to the foil absorption, only radiation with energies higher than approximately 5 keV was measured. After about 10,000 shots the diameter of the spot recorded on the X-ray film was only about 0.4 mm. This measurement gives a clear information on the high spatial stability of the beam.

In this way one can obtain intense point like X-ray sources strong coupled with the material to be irradiated; in the extreme case the material itself can be the target for the electron beam. Hence these nanosecond, intense point like sources can be attractive for some fundamental studies concerning the induced gamma emission in small quantities of isomers.

1. J. Christiansen and C. Schultheiss, *Z. Phys.* **A290** (1979) 35
2. F. Hoffman, M. Konijnenberg, C. Schultheiss, M. Schwall, K. Mittag, G. Müller, *KfK-Nachr. Jahrg.* **254** (1992) 254
3. M. Ganciu, G. Modreanu, A. M. Pointu, I.-Iovitz Popescu, *J. Phys. D: Appl. Phys.* **27** (1994) 1370
4. N. B. Mandache, A. M. Pointu, E. Dewald, M. Nistor, M. Ganciu, G. Musa, and I.-Iovitz Popescu, *Plasma Sources Sci. and Techn.* **6** (1997) 1
5. E. Dewald, K. Frank, D. H. H. Hoffmann, R. Stark, M. Ganciu, N. B. Mandache, M. Nistor, A. M. Pointu and I.-Iovitz Popescu, to appear in *IEEE Trans. Plasma Sci. (Special Issue on Pulsed Power Sci & Techn., april 1997)*

DEVELOPMENT OF AN EXCIMER LASER DRIVEN X-RAY SOURCE; APPLICATIONS TO SOFT X-RAY LITHOGRAPHY AND HOLOGRAPHY

A. Hening

Atomic Physics Institute, P.O. BOX MG-21, RO-76 900, Romania

e-mail: hening@roifa.ifa.ro

Abstract. In order to demonstrate the potential applications to nanolithography and, due to its parameters (as coherence and monochromaticity), to the field of X-ray holography, we developed a soft X-ray source from the laser produced plasma. Two kinds of laser (KrCl and KrF) have been used to generate the plasma in front of a solid target. Results and some application hints will be, also, reviewed.

The photolithographic technique for IC-manufacture will meet a limit in the continuous decrease of dimensions in semiconductor devices. Therefore, it is expected that X-ray lithography will complement present-day optical techniques in the production of ULSI circuits (feature sizes smaller than 0.1 μm) and gradually replace these "obsolete" techniques in the production of future generation of ICs. This tendency is presented, also, into the "The National Technology Roadmap for Semiconductor", edited by SIA, which sees soft X-ray lithography as one of the most promising technologies.

Successful application of X-ray lithography will, however, strongly depend on the availability of economical and reliable X-ray sources. As it is known, both resolution (RES) and deep of focus (DOF) are strongly dependent on the wavelength (λ) of the illuminating source, as well as on the numerical aperture (NA) of the projection lens.

In a first approximation, we can write:

$$\text{RES} = k (\lambda/\text{NA}) \quad (1)$$

$$\text{DOF} = \kappa \lambda/(\text{NA})^2 \quad (2)$$

with k and κ parameters defined by the photoresist capability.

Therefore, one way to elude this problem is to change the other factor from formulae (1) and (2); that is, to go at shorter wavelength. In this case we have a linear dependence of λ , and as a consequence, we could obtain a good resolution without deteriorating the deep of focus.

In this contribution, the wavelength selection criteria, the Soft X-Ray Source generated by a Laser Produced Plasmas (LPP), as an illuminating source for NANOLITHOGRAPHY (nanometer resolution lithography) will be reported.

As it is known, the main drawback of these sources is the ablation of the target material under the high irradiation of laser pulses. This process will limit the performances of the source as well as its reliability. One solution is to minimize the amount of material of the target; for that purpose, Malmqvist [1] is using small liquid droplets generated by a piezoelectrically vibrating nozzle. In this case it is required to synchronize the laser pulses with the piezo-generator in order to ensure that each laser pulse hits a single droplet. Another example is given by Fedorowicz [2] who reports the X-ray emission from a plasma produced by laser irradiation of gas puff targets. The system is quite complex, since the gas flow has to be driven by a high pressure, fast valve which must be synchronized with the laser system.

The X-ray source, presented in detail in [3], makes use of short laser pulses (in the picosecond region) in order to avoid laser heating of the target and thus, reducing the amount of material ejected as debris; moreover, by using pulse bursts (of 5-10 pulses in the picosecond range, having less than 1 ns dead time), we could farther reduce laser-target interaction, due to the plasma generated in front of the solid target by the first pulse of the burst. Indeed, the plasma generated by the first pulse lasts about 3-4 ns and acts as a shield, the next laser pulses heating mainly the plasma but not the target.

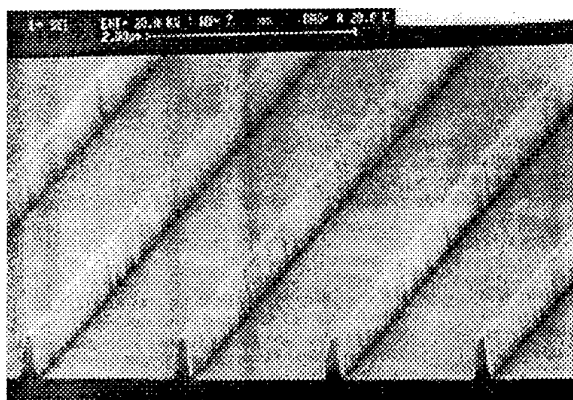

Fig. 1. SEM micrograph showing lines 100 nm wide

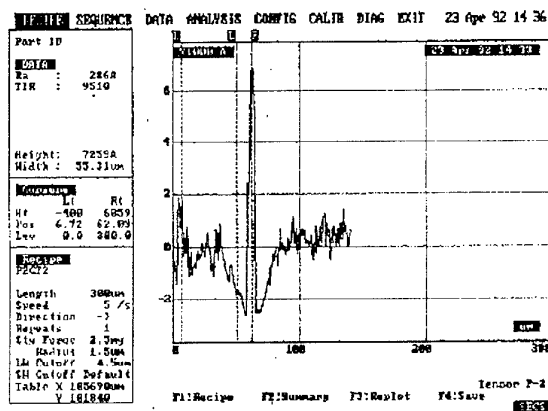

Fig. 2. Tencor P-2 scan of the etched photoresist

This soft X-ray source has been used to perform a NANOLITHOGRAPHY experiment [4], in order to demonstrate the throughput; the demonstrated resolution is better than 100 nm, as could be seen from the SEM picture (Fig. 1) and from the profilometric measurements (Fig. 2). Also, we investigated the coherence and monochromaticity of the X-ray source; an experiment of holographic recording of microbiological samples is reported in [5], together with future trends.

1. L. Malmqvist, L. Rymell and H. M. Hertz, Appl. Phys. Lett. **68** (19), 2626-29 (1996)
2. H. Fedorowicz, A. Bartnik, Z. Patron, P. Parys, Appl. Phys. Lett, **62** (22), 2778-80 (1993)
3. I. C. E. Turcu, I. N. Ross, M. S. Schulz, H. Daido, G. J. Tallents, J. Krishnan, L. Dwivedi, A. Hening, J. Appl. Phys., **73** (12), 8081-87 (1993)
4. I. C. E. Turcu, I. N. Ross, A. Hening, M. Steyer, B. Soom, J. G. Watson, P. Herman, *Microelectronics Engineering* (Elsevier), Vol.21 (1993), 95-98
5. M. S. Schultz, H. Daido, G. M. Zeng, M. Kato, S. Nakai, I. C. E. Turcu, I. N. Ross, A. Hening, OSA Proc. on *Short Wavelength V: Physics with Intense Laser Pulses*, Vol. 17, SAN DIEGO 1993 (P. B. Corkum, M. D. Perry, eds.), pp. 208-11

COMPTON BACKSCATTERING OF COHERENT DIFFRACTION RADIATION AS AN INTENSE X-RAY SOURCE

A. P. Potylitsyn

Tomsk Polytechnic University

pr.Lenina 30, Tomsk, 634004, Russia

e-mail: pap@phtd.tpu.edu.ru

In the experiment [1] X-ray production by Compton backscattering process of infra-red free electron laser (FEL) has been obtained.

Coherent diffraction radiation (DR) of a short electron bunch may be considered as a source for incident soft photons for the Compton scattering on the next bunch after reflection from a mirror with tuneable optical path. DR is emitted when the electrons are moving close to the metallic target but without interaction with the target matter.

The intensity of coherent DR is proportional to the square of the bunch charge (number of electrons) in the spectral region where the wavelength is more or compared with the bunch length l [2].

In the present report it is shown that the intensity of coherent DR into a cone with opening angle $\sim \gamma^{-1}$ (γ is the Lorentz factor) may be estimated as (here and throughout the system of units $\hbar = m_e = c = 1$ was used):

$$\frac{dW}{d\omega} \approx \frac{\alpha}{4\pi^2} \exp\left(-\frac{4\pi h}{\gamma\lambda_1}\right) N_e^2 f(\lambda_1), \quad (1)$$

where $\alpha = \frac{1}{137}$ - the fine structure constant, h - the distance between the electron beam and the edge of the target (impact parameter), $\lambda_1 = \frac{2\pi}{\omega}$ - the wavelength of DR, N_e - the number of electrons per bunch, $f(\lambda_1)$ - the bunch formfactor [3].

After Compton backscattering the spectral distribution of X-ray (for a solid angle $\sim \pi\gamma^2$ along the electron momentum) may be calculated as:

$$\frac{dN_{CBS}}{d\lambda_2} \approx \frac{\alpha}{\pi^2} \gamma^2 N_e^3 \frac{r_0^2}{\pi(\sigma_e^2 + \sigma_{ph}^2)} \frac{f(\lambda_1)}{\lambda_1} \exp\left(-\frac{4\pi h}{\gamma\lambda_1}\right), \quad (2)$$

where r_0 - the classical electron radius, $\pi\sigma_e^2$ - the area of electron beam in the interaction region,

$\pi\sigma_{ph}^2$ - the area of the incident photon beam in the interaction region, $\lambda_2 = \frac{\gamma^{-2} + \theta_1^2}{2(1 + \cos\theta_2)} \lambda_1$ - the wavelength of the scattered photons (θ_1, θ_2 - the angles between the electron beam and the incident and outgoing photons). For the electron beam with $\gamma = 500$ and $l = 0.5$ mm, DR wavelength $\lambda_1 = l$ and geometry $\theta_1 = \theta_2 = 0$, one may obtain $\lambda_2 = 0.5 \cdot 10^{-6}$ mm ($\omega_{CBS} \approx 2.5$ keV).

Due to the diffraction limit for the reflected soft photons, the size of the photon beam spot in the interaction region may be the following:

$$\tau_e \approx \lambda_1 \sim l.$$

So, one may choose the same value for the electron beam size and the impact parameter:

$$\sigma_e \approx h \sim l.$$

For this conditions the yield of X-ray for 10% bandwidth is $\Delta N \approx 10^{-28} N_e^3$, and, for a reasonable value of $N_e = 10^{11}$ e⁻/ bunch, the intensity of X-ray may reach 10^5 photons/bunch.

Characteristics of the similar X-ray beam generated by 250 MeV LINAC may be compared with the X-ray beam after Compton backscattering of intracavity storage ring FEL radiation [4].

1. F. Glotin, J. M. Ortega, R. Prazeres *et al.*, Phys. Rev. Lett. **77**, 3130 (1996)
2. Y. Shibata, S. Hasebe, K. Ishi *et al.*, Phys. Rev. E **52**, 6787 (1995)
3. K. Ishi, Y. Shibata, T. Takahashi *et al.*, Phys. Rev. A **43**, 5597 (1991)
4. G. Dattoli, L. Giannessi, A. Torre *et al.*, NIM A **375**, 543 (1996)

COHERENCE IN NUCLEAR RADIATION**R. Coussement, J. Odeurs, G. Neyens, C. L'Abbé**

Instituut voor Kern- en Stralingsfysica, University of Leuven

Celestijnenlaan 200 D, B-3001 Leuven, Belgium

In nuclear physics the probability of a radiation process involving N nuclei is usually considered to be just N times the probability for a single nucleus. Also when a nucleus can decay to two or more hyperfine levels one just adds the probabilities. However, elementary quantum mechanics tells us that the amplitudes must first be added and then squared. This procedure differs from the usual one by the occurrence of interference terms. Such interference terms are observed in, amongst others, perturbed angular correlation experiments. In most of the other experiments, the interference terms cancel when averaged over an ensemble because of a random phase integration. Interference between the scattering amplitudes involving different nuclei has been largely used in nuclear resonant scattering. This interference is a consequence of the coherent excitation in the spatial and / or the energy domain. We will discuss the possibility to have emission without absorption and its consequences in the concept of a laser with gamma radiation. We will also study the cooperative effects when an ensemble of nuclei interacts with the gamma radiation.

COOPERATIVE EFFECTS IN STIMULATED GAMMA EMISSION**J. Odeurs, R. Coussement, G. Neyens**

Instituut voor Kern- en Stralingsfysica

Katholieke Universiteit Leuven

Celestijnenlaan 200 D

B-3001 Leuven

Belgium

For any laser system, based on the concept of lasing with or without population inversion, the principle of stimulated emission is crucial. For gamma-radiation, the stimulated emission cross section for isolated nuclei is several orders of magnitude smaller than the corresponding quantity in atomic physics. This implies that the amplification factor in the process of stimulated emission is extremely small for nuclear transitions if one deals with an ensemble of excited nuclei acting independently. In this case the stimulated emission probability is proportional to the number of excited nuclei N . However, if a mechanism could be found, according to which cooperative effects play a role, the probability for stimulated gamma emission could be enhanced. When nuclei are incorporated in a single crystal, a special coherent nuclear state, corresponding to the nuclear excitation spread over all resonant nuclei in the lattice, would produce a stimulated emission probability proportional to N^2 . This occurs for certain well-defined emission directions, corresponding to the reciprocal lattice vectors in the crystal.

**STATUS OF THE EXPERIMENTS ON GRAVITY AND EARTH MAGNETIC FIELD
EFFECTS ON THE ^{109}Ag γ -RESONANCE**

V. G. Alpatov, Yu. D. Bayukov, A. V. Davydov, Yu. N. Isaev,

G. R. Kartashov, M. M. Korotkov, V. M. Samoylov

Institute of Theoretical and Experimental Physics (ITEP), Moscow, Russia

In connection with the possible influence of the outer magnetic field direction on the value of the resonant self-absorption of ^{109}Ag 88 keV γ -rays in silver single crystal [1], we were forced to alter completely the set-up intended for the experiments on the search for the gravity influence on the ^{109}Ag γ -resonance [2]. All ferromagnetic parts are changed by the components of nonmagnetic materials. The set-up is oriented so that the horizontal beam of γ -rays emitted by the sources inside the cryostat is aligned in the magnetic meridian plane. It was found that previously fabricated auxiliary (control) γ -source of ^{57}Co in silver foil exhibited ferromagnetic properties and must be replaced by the new one. For this reason, the method of preparation of a control source using ^{241}Am was developed by means of saturation of the chromatographic paper rings with nitrate americium solution. The source formed as a disk of concentric paper rings was encapsulated into aluminum foil by cryoresistant glue. Vacuum test and repeated immersions in liquid nitrogen shown the absolute tightness of the source. The set-up is equipped with a pair of Helmholtz coils coaxial with the cryostat. These coils allow the compensation of the vertical component of the Earth field with accuracy of 0.001 Oersted. When the coils are switched on, the outer magnetic field (that of Earth) is directed horizontally in the area of γ -source location and parallel to the horizontal γ -beam. In such a case, the resonant γ -ray absorption probability in the horizontal beam must be maximal [1]. The periodic switching of the coils on and off must lead in accordance with theory [1] to the synchronous variations of the ^{109}Ag γ -ray resonant absorption probability in the horizontal γ -beam. The amplitude of these variations may achieve ~ 60% of maximal absorption value. The effect of this switching must be absent on the vertical ^{109}Ag γ -beam intensity and on the γ -radiation of the control γ -source in both directions.

By means of an optical device, including the theodolite and the system of mirrors and illuminators, long time observations of the helium volume position of the cryostat at room temperature are being performed. The chaotic deviations with time were found by theodolite readings. These deviations may be connected with the real fluctuating deformations of the cryostat and also with the errors of the theodolite. The root-mean-square value of these variations is to be found from these measurements and probably it will lie in the hundreds mcm region.

Now, measurements of the temperature dependencies of the γ -line intensity ratio are in progress for two γ -sources: the main one (^{109}Cd in silver single crystal) and the control one (^{241}Am in the paper disc). The measurements are to be performed at three temperatures (room, 77 K and 4.2 K) for two directions of the γ -ray emission - the horizontal and the vertical ones. At each temperature, the effect of the direction change of the outer magnetic field is measured by means of periodic switching the Helmholtz coils on and off. We hope that we shall dispose of the experimental results till the beginning of the Symposium. These results would permit to estimate the broadening factor of the ^{109}Ag γ -resonance.

This work is performed under the financial support of Russian Fund for Fundamental Investigations and under the personal support of A. V. Davydov by ICIGE and EOARD.

1. A. V. Davydov, Yu. N. Isaev, V. M. Samoylov, Preprint ITEP 48-96. To be published in "Izvestia RAN", Ser. Phys., 1997
2. A. V. Davydov, The report at the GARALAS symposium ("Predeal-95"), 1995. To be published in the "Hyperfine Interactions"

EXCITATION OF THE LONG LIVING ISOMERS $^{107m,109m}\text{Ag}$ IN THE FAST NEUTRON INELASTIC SCATTERING REACTIONS

V. G. Alpatov ^a, S. B. Borzakov ^b, A. V. Davydov ^a, Yu. N. Isaev ^a,
G. R. Kartashov ^a, M. M. Korotkov ^a, V. M. Nazarov ^b, S. S. Pavlov ^b,
V. F. Peresedov ^b, V. E. Rad'ko ^a, V. M. Samoylov ^a, V. P. Chinaeva ^b

^a Institute of Theoretical and Experimental Physics (ITEP), Moscow, Russia

^b Joint Institute for Nuclear Research (JINR), Dubna, Russia

The publications of the last years [1-5] on the experiments the results of which were interpreted by the authors as evidence of the small broadening factor of the ^{109}Ag γ -resonance in the silver single crystals lead to the new rise of interest in the problem of γ -laser development using similar isomers. In connection with this, investigations of the possibilities of large isomeric activity production, of isomer separation from the rest of atoms and of forming the gamma laser working medium of separated isomers became necessary. Because of the rather long half-lives of these isomers (about 1 min for $^{107m,109m}\text{Ag}$), one may hope that it would be possible to develop the technologies permitting to perform the totality of the required operations during these times.

One of the most effective methods to produce the nuclei in the long living isomeric states is connected with the inelastic scattering reaction of fast neutrons. It is known [6] that the cross section of this reaction, leading to the excitation of such an isomeric state as, for example, that of ^{103}Rh with an energy of 39.756 ± 0.006 keV and $T_{1/2} = 56.12 \pm 0.01$ min exceeds 1 barn at neutron energy about 3-6 MeV.

In connection with this, we performed the experiment on the measurement of the excitation cross sections for the isomers $^{107m,109m}\text{Ag}$ in the reactions of fast neutron inelastic scattering at the IBR-2 reactor of JINR (Dubna). The measurements were conducted on the device "Regata" which was a branched pneumoline permitting to guide the samples for neutron irradiation in different channels of the IBR-2 reactor including the channel K1 which is shielded by cadmium against the low energy neutrons. This channel was used in present work to irradiate the samples.

Several foil samples of natural silver with masses from 7.2 to 15.5 mg and 0.192 mm in thickness in small polyethylene containers were irradiated in turns by neutrons during 1 min and then they were transported by pneumatic mail to the place of taking out. The mean time between

the end of the irradiation and beginning of the sample gamma activity measurement was equal to 115 s. This time was formed of the container moving time in the pneumotube, the cooling time of the container and the time for container detachment and for carrying the sample to the detector. Measurement of the sample γ activity continued 1 min by means of the small X-ray detector of high purity germanium with resolution of 0.55 keV at 40 keV γ -ray energy. The dependence of the detector efficiency on the γ -ray energy was measured using the set of standard γ emitters.

The cross sections of silver isomer excitation were determined by a comparison of the Ag sample activities with that of the Rh sample which was irradiated by the same neutron flux. The cross sections of the ^{103m}Rh isomer excitation were measured in several works of which the work [6] contained the most detailed data in the energy region of interest. Averaging of the data [6] on the fast neutron spectrum of the IBR-2 reactor gives the mean cross section value of 386 ± 24 mb. Note that for pure spectrum of fission neutrons this value is equal to 708 ± 43 mb [6].

The difference may be explained by the softer spectrum of IBR-2 neutrons as compared with pure fission spectrum because the neutron moderator is placed near the reactor core of IBR-2.

The following values were obtained for the excitation cross sections of $^{107m,109m}\text{Ag}$ isomers:

$$\sigma(^{107}\text{Ag}) = 204 \pm 20 \text{ mb.}$$

$$\sigma(^{109}\text{Ag}) = 262 \pm 29 \text{ mb.}$$

1. W. Wildner, U. Gonzer, J. de Physique, Colloque C2, Suppl. au N° 3, 40, C2-47 - C2-48 (1979)
2. R. D. Taylor, G. R. Hoy, SPIE, 875, *Short and Ultrashort Wavelength Lasers*, 1988, p. 126-133
3. G. R. Hoy, R. D. Taylor, J. Quant. Spectrosc. Radiat. Transfer 40 (6), 763-771 (1988)
4. S. Rezaie-Serej, G. R. Hoy, R. D. Taylor, Laser Physics 5 (2), 240-257 (1995)
5. V. G. Alpatov, A. V. Davydov, G. R. Kartashov et al. Izmeritel'naya Tehnika 3, 52-55 (1995)
(in Russian)
6. D. C. Santry, J. P. Butler, Can. J. Phys., 52, 1421-1428 (1974)

**MEASUREMENT OF THE MÖSSBAUER FACTOR f
FOR ^{125}Te γ -RAYS IN BERYLLIUM TELLURIDE**

V. G. Alpatov, A. V. Davydov, Yu. N. Isaev, G. R. Kartashov,

L. Ya. Memelova, A. A. Sadovsky, N. I. Tret'yakova

Institute of Theoretical and Experimental Physics (ITEP), Moscow, Russia

Experiments were performed in order to determine the Mössbauer factor f for 35.5 keV ^{125}Te γ -rays in beryllium telluride in connection with definite interest in a study of the possibility of using the long living isomers similar to ^{125m}Te to produce the induced γ -radiation (IGE). Beryllium telluride was used for this goal in some works [1-3]. One may not consider the results of these experiments as the undoubted ones. The production cross sections of IGE were estimated in these works using the assumption that the Debye temperature θ_D of beryllium telluride is equal to ~ 400 K. If the real value of θ_D is lower, then the doubts in the possibility to interpret the [1-3] results as the exhibition of the IGE would increase because the cross sections for the observed effects would be too large.

The present experiments were performed using the method of measuring the temperature dependence of the 35.5 keV γ -ray self-absorption in thick γ source containing a definite amount of ^{125}Te nuclei and also using the "black" absorbers. The measurements were made at room temperature and at 77 K and ~ 25 K with several samples of beryllium telluride. The X-ray structural analysis of these samples shown the presence of an one and only phase with characteristics of beryllium telluride. As a result of the measurements performed with 4 samples at three temperatures (8 measurements in all) the data showing that the values of θ_D calculated from the measured values of f laid in rather narrow scale interval were obtained, the mean value of θ_D being equal to 206.5 ± 5.0 K. The comparison of the self-absorption experiments data with those obtained with "black" absorbers shows that the possible broadening of the 35.5 keV γ -line does not exceed 1.5 (the effect of this broadening does not reveal itself in the measured values of f , but may be hidden in the experimental errors). Similar measurements with metallic Te and with tellurium oxide gave for θ_D values which agreed with the data of previous works by other authors.

Note that if free amorphous tellurium was present in our samples, which did not take part in the reaction with beryllium and couldn't be found by the X-ray structural analysis, then our value of θ_D would be underestimated. Thus, to obtain the final conclusion about θ_D magnitude of beryllium telluride, additional experiments are required particularly connected with the preparation of TeBe at different temperatures and at different times of warming up.

1. G. A. Skorobogatov, B. E. Dzevitskii, *Izv. Akad. Nauk SSSR, Ser. Phys.* **48**, 1934 (1984)
2. V. G. Alpatov, G. E. Bizina, A. V. Davydov *et al.*, *Izv. Akad. Nauk SSSR, Ser. Phys.* **50**, 2013-2015 (1986)
3. V. G. Alpatov, G. E. Bizina, S. C. Godovikov *et al.*, Book of report abstracts of 37-th Conference on Nuclear Spectroscopy and Atomic Nucleus Structure, Leningrad, "Nauka", 1987, p. 224

QUADRUPOLE GAMMA SUPERRADIANCE

S. N. Andrianov *, V. V. Samartsev **

* State Institute of Applied Optics, Lipatova Str. 2, Kazan, 420075, Russia

** Kazan Physical and Technical institute of Russian Academy of Sciences,
Sibirsky Trakt Str. 10/7, Kazan, 420029, Russia

Abstract. The superradiance process on the quadrupole transition of nuclei is considered. Its kinetics is analyzed using nonequilibrium statistical operator method. Effective spin $S = 1$ is introduced in order to account the cascading character of the quadrupole transitions. It is shown that the kinetics of quadrupole superradiance differs essentially from that of dipole one. The decay time can be sufficiently shorter, the time envelope steps aside from usual secant form and the peak intensity can be proportional to the fourth degree of radiating particle number. The last, most striking fact, however, is possible only when the macroscopic quadrupole is formed by combining all nuclei in radiating pairs. In other case, the usual quadratic dependence is observed as simple consequence of unidirectivity for separate microscopic quadrupoles.

Quantum superradiance is a method to obtain powerful pulsed electromagnetic generation that is alternative to the laser method [1]. It was shown both theoretically and experimentally that the system of preliminary inverted atomic dipoles can undergo in certain conditions the self correlation transition to coherent state of macroscopic dipole and emit strong pulses of quanta with the intensity proportional to the quantity of nuclei N . As to the nucleus system, multipole transitions prevail there. So, we consider here the possibility of quadrupole superradiance (QSR).

We are using the model taking into consideration the cascading character of the quadrupole transitions (E2), when the total angular momentum changes on to two under the emission of one gamma-photon. This model is the modification of electro-dipole Dicke model for the quadrupole transitions. We must take into consideration the three working levels: ground - with the angular momentum J , intermediate - with $J \pm 1$, excited - with $J \pm 2$. Therefore we must introduce the effective spin $S = 1$. Under that, the operators of rise and fall of the effective spin projection correspond formally to the operators of change of the total angular momentum of nucleus on unit. When separate nuclei quadruples are equally oriented in space as a consequence of self correlation process, these operators can be substituted by relevant collective operators divided by N . So, the total hamiltonian can be written as the following:

$$H = \hbar\omega_0 R_z + \hbar\omega_{\vec{k}} a_{\vec{k}}^+ a_{\vec{k}} + g_{\vec{k}} a_{\vec{k}} (R_{\vec{k}}^+)^2 + g_{\vec{k}}^* a_{\vec{k}}^+ (R_{\vec{k}}^-)^2 \quad (1)$$

where $\hbar\omega_0$ is an energy separation between nucleus levels, $\hbar\omega_{\vec{k}}$ - the energy of gamma quantum, R_z - operator of collective population difference, $a_{\vec{k}}^+$ and $a_{\vec{k}}$ - operators of creation and annihilation of gamma quantum with wave vector \vec{k} . This hamiltonian formally coincides with that of macroscopic quadrupole interacting with gamma quanta. The difference is that here interaction constant is normalized by N because separate quadrupoles don't form the macroscopic one by their simple coherent summation as in the case of dipoles. An example of nuclear systems with macroscopic quadrupole momentum may be clusters arising in nuclear matter with increasing density. Even-even (plus) nuclei such as ^{114}Ba , ^{150}Sm , ^{220}Rn , ^{220}Ra radiate spontaneously only on the E2 transition without electro-dipole and multipole transition [2]. So, with increasing density of nuclei these systems become real candidates for observation of QSR.

Using nonequilibrium statistical operator method, we can derive from hamiltonian (1) the following kinetic equation:

$$\frac{d\langle R_z \rangle}{dt} = -\frac{2}{\tau_1} \left(N + \langle R_z \rangle + N^2 - \langle R_z \rangle^2 \right)^2 \quad (2)$$

where:

$$\frac{1}{\tau_1} = \frac{2\pi}{\hbar^2} |g_{\bar{k}}|^2 \delta(\omega_{\bar{k}} - 2\omega_0) \quad (3)$$

is the reversal time of isolated transition. The numerical solution of equation (2) yields the intensity of QSR:

$$I = -\hbar\omega_0 \frac{d\langle R_z \rangle}{dt} \quad (4)$$

The approximate analytical solution of equation (2) writes in the vicinity of QSR peak as follows:

$$I = 4N^4 \frac{\hbar\omega_0}{\tau_1} \operatorname{sech}^2 \frac{t - t_0}{2\tau_c} \quad (5)$$

where $\tau_c = \tau_1 / (2N)^3$ is a correlation time and $t_0 = \tau_c N$ is a delay time.

Being measured in τ_c , the delay time is much longer than that of usual dipole superradiance. With that, correlation time is much shorter than ordinary that is $\tau_c = \tau_1 / N$. But one should remember that τ_1 is independent of N only in the case of macroscopic quadrupole formation. In the case of separate quadrupole ordering, τ_1 is proportional N^2 and τ_c has the usual N dependence. So, the decay time in absolute units is always longer than in the dipole case for microscopic quadrupole superradiance and always shorter for macroscopic one. The peak intensity is proportional to the fourth degree of radiating nuclei in the case of macroscopic QSR and to the second degree, as that of dipole in the case of microscopic QSR.

Yet, microscopic QSR has some advantages being compared with dipole superradiance. Allowed dipole transitions are very fast in gamma range. So, it is difficult to satisfy cooperation length requirements [3] and only swept-gain superradiance will be realized in practice [4]. Quadrupole transitions are much longer and these requirements can easily be satisfied.

1. R. H. Dicke, Phys. Rev. **93**, 99, (1954)
2. V. Y. Denisov and A. Y. Dzyublik, Nuclear Physics A **589**, 17 (1995)
3. F. T. Arecchi and E. Courtens, Phys. Rev. A **2**, 1730 (1970)
4. R. Bonifacio *et al.*, Phys. Rev. A **12**, 2658, (1975)

GAMMA SUPERRADIANCE STIMULATED BY LASER COOLING

S. N. Andrianov ^{*}, V. V. Samartsev ^{**}

^{*}State Institute of Applied Optics, Lipatova Str. 2, Kazan, 420075, Russia

^{**}Kazan Physical and Technical Institute of Russian Academy of Sciences,
Sibirsky Trakt Str. 10/7, Kazan, 420029, Russia

Abstract. The application of laser cooling to obtain powerful coherent pulses of gamma radiation is considered using the effect of quantum superradiance. Two main problems are analyzed: the possibility to quench relaxation processes by laser cooling and superradiance without inversion in laser cooled systems. Both stationary and dynamic regimes of laser cooling studied. Several model cases are investigated theoretically: quenching of inhomogeneous relaxation by laser cooling in traveling wave, quenching of homogeneous relaxation by side-band laser cooling of phonon and dipole-dipole subsystems, creation of effective inversion in nuclear systems with superfine interaction, atomic beams and optical molases.

The influence of inhomogeneous phase relaxation on superradiance was considered in many papers. Here we will employ a simple academic model developed in [1]. In accordance with this model, the superradiance intensity can be written as:

$$I = -\frac{N\hbar\omega_0}{\tau_c} e^{1/T_2^*} \operatorname{sech}^2 \left[\frac{T_2^* (1 - e^{-t/T_2^*}) - t_0}{2\tau_c} \right], \quad (1)$$

where ω_0 is the central frequency of transition, T_2^* is the time of the inhomogeneous transverse relaxation, and t_0 is the integration constant. The time when the maximum of superradiance pulse is achieved is given by an approximate formula:

$$t_0^* = -T_2^* \ln(1 - t_0 / T_2^*). \quad (2)$$

Consequently, the maximum intensity is written as:

$$I = N \frac{\hbar\omega_0}{\tau_c} (1 - t_0 / T_2^*). \quad (3)$$

The Doppler width $\delta\omega = 1/T_2^*$ that corresponds to laser cooling to the temperature T is determined in accordance with the following formula [2]:

$$\frac{1}{T_2^*} = k\Delta v = k(2k_B T / m)^{1/2}. \quad (4)$$

Expressions (3) and (4) demonstrate that laser cooling provides favorable conditions for superradiance.

Laser cooling has a beneficial effect on superradiance also in the case of homogeneously broadened systems. A phenomenological consideration of homogeneous phase relaxation with relaxation time T_2 [3] yields the following formula for superradiance intensity:

$$I = N \frac{\hbar\omega_0}{4\tau_c} \left(1 - \frac{\tau_c}{T_2}\right)^2 \operatorname{sech}^2 \left[\frac{1}{2} \left(\frac{1}{\tau_c} - \frac{1}{T_2} \right) (t - t_0) \right]. \quad (5)$$

Microscopic calculations performed in [4] lead to the same formula for superradiance in a crystal, where dephasing due to phonon scattering is described by:

$$\frac{1}{T_2} = \frac{2\pi}{\hbar^2} \sum_{q \neq q'} (\delta\varphi_{qq'})^2 \bar{n}_q (\bar{n}_{q'} + 1) \delta(\Omega_q - \Omega_{q'}), \quad (6)$$

where Ω_q and n_q are the frequency and the phonon number in the mode q , respectively, and $\delta\varphi$ is the constant of dipole-phonon coupling. In the case of the laser cooling of an isolated phonon mode, the number of phonons in the isolated mode is given by:

$$\bar{n} = \frac{\tau_1}{\tau_1} \left(\frac{\rho\Delta}{N} \right) n_0, \quad (7)$$

where n_0 is the initial number of phonons, ρ is the spectral density of phonons, Δ is the spectral bandwidth of the isolated mode, N is the number of impurity molecules, and τ_1 is the rate of sample heating. In the case of laser cooling we have $\bar{n} \ll n_0$. Thus, if the selected mode of resonance phonons provides the main contribution to scattering, then the formulas (5) and (6) demonstrate a beneficial effect of laser cooling on superradiance. Note that the opposite case of an adverse effect of lattice heating on superradiance was experimentally and theoretically studied in [5].

Laser cooling can also be used to ensure conditions for the detection of superradiance in dipole-dipole homogeneous broadening of the emission line because, as is well known, a microwave field, for example, can cool a dipole-dipole reservoir [6]. These concepts can be applied to gamma superradiance of nuclear excitons. In paper [7] we considered superradiance from Frenkel excitons in a molecular crystal due to nonequilibrium Bose condensation, i.e. due to spontaneous cooling. Importantly, such cooling processes not only weaken dephasing, but also give rise to correlations between atoms due to the macroscopic filling of the coherent excitonic mode.

The noncoherent spontaneous emission of nucleus system can be made anisotropic by optical polarization of nuclei. Laser cooling of superfine subsystem can create conditions for gamma superradiance due to enhancement of angular and frequency selectivity of radiation process.

One can also apply laser cooling to solve the problem of population inversion by inducing effective inversion within a narrow spectral range with partial excitation of the entire inhomogeneously broadened line. Monochromatization of N_0 excited nuclei by means of laser cooling (through an optical transition in the excited state of nucleus) makes possible to concentrate these nuclei within a narrow spectral and, possibly, spatial range, which gives rise to effective inversion. In accordance with formula (4), this effect becomes noticeable when the temperature of the excited samples reaches the value of:

$$T = \left(\frac{N_0}{N} \right)^2 \frac{1}{(kT_2^*)^2} \frac{m}{2k_B}, \quad (8)$$

where $(T_2^*)^{-1}$ is the total spectral width of all atoms. In this case, the spectral density of excited nuclei becomes equal to the equilibrium spectral density. When the recoil frequency shift exceeds the Doppler width, inversionless superradiance is possible without frequency concentration since only preliminary excited atoms can interact through the radiation field, because only the recoil of an atom in the course of emission can keep energy and momentum conservation in subsequent absorption.

1. R. Bonifacio and L. A. Lugiato, Phys. Rev. A **11**, 1507; **12**, 587 (1975)
2. V. G. Minogin and V. S. Letokhov, *Pressure of laser radiation on atoms*, 1986, Moscow, Nauka
3. A. V. Andreev, Pis'ma Zh. Eksp. Teor. Fiz. **3**, 779 (1977)
4. Yu. V. Naboikin, S. N. Andrianov, P. V. Zinov'ev *et al.*, Zh. Eksp. Teor. Fiz. **89**, 1146 (1985)
5. S. N. Andrianov, P. V. Zinov'ev, Yu. V. Malykin *et al.*, Zh. Eksp. Teor. Fiz. **91**, 1990 (1986)
6. W. Th. Wenckebach, T. T. B. Swancburg, N. J. Poulis, Phys. Reports **14**, 181 (1974)
7. S. N. Andrianov, V. V. Samartsev, Yu. E. Sheibut, Teor. Mat. Fiz. **72**, 286 (1987)

COOPERATIVE GAMMA-RAY GENERATION STIMULATED BY X-RAY PULSE

N. A. Enachi ^{a,b}, M. A. Macovei ^a^a Institute of Applied Physics, Academy of Sciences of Moldova,
Academiei str. 5, Kishinev MD-2028, Moldova^b Institute of Atomic Physics, IFIN, 4 sec., Magurele, Bucurest, Romania

Abstract. The two-photon generation gamma ray superradiance stimulated by X-ray pulse in inverted nuclei system is discussed. It is shown that the three level system of isomer nuclei which is in resonance or far from resonance with an external X-ray partial coherent source can generate gamma photons with interesting statistical properties.

The problem of gamma-ray coherent generation in the process of excitation of long-living isomers with X-ray photons is one of the very interesting problems of quantum nucleonics, and is intensively studied in the last years [1-3]. For example, in the papers [1, 2] the resonant photoexcitation of 19 isomeric nuclei and the possibility of coherent gamma-ray emission of the stored energy were examined.

Because the intense flashes of X-ray could dump the stored energy of $^{180}\text{Ta}^m$ and $^{178}\text{Hf}^m$ isomers, we propose the theoretical model of interaction pencil shape isomer system with partial coherent pulse of X-ray photons. The possibility of cooperation of inverted nuclei system through the X-ray and gamma-ray photons in the process of two-photon transitions from isomer state to ground state of nuclei is discussed. We consider that the short lifetime level $|3\rangle$, lying above isomer state $|2\rangle$ and the two-photon transition stimulated by X-ray source take place via the intermediate state $|3\rangle$. We consider that the external X-ray source is off resonance (or in resonance) with short-living level $|3\rangle$ (see figs. 1 and 2). We show that the two-photon polarisation of the nuclei depends not only on the square of the number of inverted nuclei, but also on the intensity and frequency of external X-ray source, and the statistics of gamma-ray emission strongly depends on the statistics of X-ray photons. In this situation the correlation function between the intensities of X-ray and gamma-ray photons can play an important rule.

If the dipole active $|3\rangle$ level is in resonance with the coherent X-ray radiation (see fig.2) the dynamically Stark decoupling of short-living level $|3\rangle$ is possible. Here, the two gamma-ray superradiant pulses are possible.

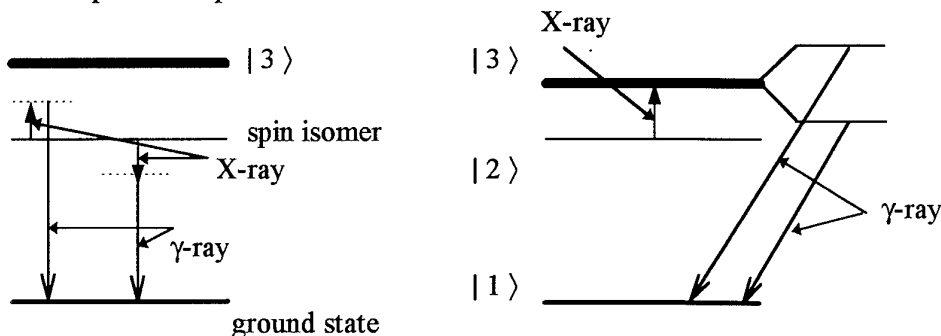

Fig. 1

Fig. 2

1. C. B. Collins *et al.*, Phys. Rev. C **37**, 2267 (1988)
2. J. J. Carroll *et al.*, Phys. Rev. C **43**, 1238 (1991)
3. Enaki, Sov. Phys. JETP **67**, 2033 (1988)

GAMMA-SPECTROSCOPIC TRANSITIONS CONTROLLED BY RADIOFREQUENCY FIELDS

E. K. Sadykov, S. A. Alexeev, L. L. Zakirov

Kazan State University, Kazan 420008, TATARSTAN, Russia

Abstract. Investigation of gamma-spectroscopic transitions parameters in case of controlled nuclear spin dynamics is a traditional trend of Mössbauer spectroscopy. Coherent perturbation of nuclei (e.g. by rf fields) is for a long time connected with a possibility of an inhomogenously narrowing of broadened lines [1] and splitting and shifting of hyperfine structure lines of Mössbauer spectrum [2]. The most tempting idea is to achieve an inversionless amplification regime using gamma-transitions [3] – rf field is used in this case to prepare the coherent blend of nuclear states, for which gamma-transition is forbidden. Such suppositions are usually based on the theoretical and experimental works in coherent optics, where the works on self-induced transparency and inversionless amplification have been greatly developed last years. In the same time, although the main principles describing the expected phenomena are equivalent, gamma-range is less suitable to achieve conditions necessary for the realization of such phenomena.

In this report an analysis of radiofrequency magnetic field effects in gamma-optics is made. The discussed effects are compared with similar effects in optics, where there are more possibilities to control the spectroscopy transitions dynamics [4]. Our interest is focused on the characteristics (frequencies, polarization) of spontaneous and induced gamma-radiation emitted by coherently driven nuclear spins. The main question is one of reciprocity (symmetry) of induced absorption and emission transitions. The violation of this reciprocity means a possibility of inversionless amplification. Our calculations show that such violation does not take place when nuclear spins are perturbed coherently in a stationary mode. This is also revealed by previous works [2,5]. The possible methods of violating the reciprocity mentioned above are like in optics connected with transient and impulse rf processes. The realization of these for systems of nuclear spins in solids is a complicated enough problem.

In making calculations we have used quasi-energy states formalism. Such representation allows a more definitely description of the quantum interference mechanism for spectroscopic transitions. Many peculiarities of Mössbauer spectra in case of coherent spin dynamics received earlier using superoperators technique are easily obtained in this representation. A set of

quasi-energy states may serve as an orthonormal basis. The effects of temporal beats in spectra [6] are being received in a natural way using quasi-energy states. A mechanism of narrowing the inhomogeneously broadened spectrum lines under coherent pumping is also easily demonstrated. With quasi-energy states it is easier to understand the nature of spontaneously emitted gamma-quanta, which may be interpreted as the superpositioned states of photons with different polarization and energy.

Speaking about alternate field at the nucleus, we mean it to be externally created or induced by electron magnetism and rf field. In latter case (especially for Fe^{57} isotope) there is a problem of a mechanism of transformation of an external rf field into the coherent field at the nucleus. In general, this transformation is connected with a possibility of coherent magnetization reversal of the sample. This question becomes especially important in case of an external rotating field. We have studied this question using numerical simulation of the Landau-Lifshitz equation. We have shown, in particular, that the sample magnetization follows the rotating field if the angular speed of rotation Ω is much less than Larmor frequency $\gamma_e H_A$, where γ_e is a gyromagnetic ratio constant, H_A the alternate field amplitude. This coincides with a condition of adiabatic theorem known in nuclear magnetism [7]. Such motion of magnetization, synchronous with the external rotating field is expected in easy-plane magnetic substances (e.g. FeBO_3), until frequency decrease does not disturb adiabatic condition. If taking easy-plane anisotropy fields into account, magnetization motion changes in some manner and, in particular, threshold frequency at which stable motion is still possible decreases. Similar numerical simulation of sample magnetodynamics (or the behavior of hyperfine field at nucleus) allows also to explain the peculiarities of Mössbauer spectra observed in an oscillating rf field.

1. Yu. A. Il'insky, R. V. Khokhlov, Usp. Fiz. Nauk **110**, 449 (1973)
2. E. K. Sadykov, A. G. Isavnin, Laser Physics **5** (2), 441 (1995)
3. R. Coussement, M. Van den Bergh, G. S'heeren, G. Neyens, R. Nouwen, R. Bolchand, Phys. Rev. Lett. **71** (12), 1824 (1993)
4. O. A. Kocharovskaya, Laser Physics **5** (2) 284-291, (1995)
5. M. Salkova, S. Stenholm, Phys. Rev. A **41** (7), 3838 (1990)
6. A. V. Mitin, Phys. Lett., A **84**, 278 (1981)
7. A. Abragam, *Principles of nuclear magnetism*, Oxford, 1961

RADIOFREQUENCY MODULATION OF ^{57}Fe HYPERFINE INTERACTION BY ROTATING MAGNETIC FIELD

F. G. Vagizov, R. A. Manapov, E. K. Sadykov * and L. L. Zakirov *

Kazan Physical-Technical Institute, Russian Academy of Sciences,
Sibirsky Tract 10/7, 420029 Kazan, Russia

*Kazan State University, Lenin str. 18, 420008 Kazan, Russia

Optical resonance fluorescence provides a new approach to the field of gamma-ray optics. In analogy with the optical resonance it may be interesting to study the influence of a rotating radiofrequency magnetic field on the nuclear radiation observing Mössbauer hyperfine pattern changes. The point in one of these optical experiments is this [1]: if we decompose the linearly polarized radiation emerging at right angle to the source plane into two counter-rotating circularly polarized components, and if the plane of linear polarization rotates at constant angular speed, the frequency of one of these components will increase and the other will decrease. This will reveal itself as a splitting of Mössbauer lines.

According to the theory [2, 3] the rotating rf field causes splitting of each hyperfine Mössbauer line into two components separated by an energy interval equal to twice the external rf field frequency. The relative intensity of these components is strongly dependent on the rf field frequency. When the latter is less than the nuclear Larmor precession frequency, but more than the natural linewidth of the Mössbauer line, the split lines are well resolved and of the same intensity.

In the present work we report theoretical and experimental investigations on the effect of directional changes of the hyperfine magnetic field caused by the external rotating rf field. The rf modulation of ^{57}Fe hyperfine interaction by rotating magnetic field was studied in thin Permalloy foil. It was investigated as a function of intensity for several rf field frequencies. The experiments show that the external rotating rf field causes a considerable change in the hyperfine pattern. The recorded spectra are in disagreement with those obtained by Perlow [1]. They also are inconsistent with the magnetostriction hypothesis. Proceeding from the Mössbauer spectrum analysis, one may conclude that the magnetization of the investigated foil changes its direction in a complex manner. However, the undertaken experiments show that the essential number of Mössbauer nuclei experience the rotating magnetic field influence.

1. G. J. Perlow, *Phys. Rev.* **172**, 319 (1968)
2. E. K. Sadykov, A. G. Isavnin, *Laser Physics* **5**, 411 (1995)
3. E. K. Sadykov, A. G. Isavnin, A. I. Skvortsov, *Hyperfine Interactions* (in press)

COHERENT RESONANT SCATTERING UNDER TOTAL EXTERNAL REFLECTION

V. N. Gitsovitch, V. G. Semenov, I. A. Sergeev, G. A. Skorobogatov

Dept. of Chemistry, St. Petersburg State University,

Petrodvorets, 198904 St. Petersburg, RUSSIA

e-mail: vic@mail.moss.pu.ru

We report experimental results of coherent nuclear reflection from Mössbauer medium under the condition of total external reflection (TER). For the same samples we used both grazing incidence Mössbauer spectroscopy (GIMS) and synchrotron radiation (SR), to record the energy and time-domain spectra to get information about the angle and time-dependent reflectivity of the medium's both coherent and noncoherent radiations.

As a reflecting Mössbauer medium we used Fe/Cr periodic multilayer - sample #1, and Fe-Cr alloy (Fe - 60%) - sample #2. Both samples were prepared by means of laser evaporation on float glass substrate having root mean square dispersion of roughness less than 0.4 nm. Both samples had 50 nm Cr films between the substrate and the resonant Fe-Cr medium and they also had been covered with 10 nm Zr antireflection films to suppress electronic reflection at the definite angle. The total thickness of the Fe-Cr medium both for #1 and for #2 was about 25 nm.

Sample #2 demonstrated single line GIMS spectra while sample #1 demonstrated hyperfine structure in energy- and quantum beats in time-domain (SR) spectra.

We measured the SR reflection as function of angle to determine the angle range giving the maximum coherent reflection under TER and also under Bragg conditions.

The time-domain spectra demonstrated speed-up of the decay due to enhancement of the radiative channel.

This work was supported by RFBR # 96-03-33342a.

**A COOPERATIVE MECHANISM OF IGE IN A POLYCRYSTAL MATRIX
CONTAINING Te-125m, Te-123m, etc.**

G. A. Skorobogatov, Yu. A. Romashov
Dept. of Chemistry, St. Petersburg State University,
198904, St. Petersburg, Russia

The interaction of a radiation field with an elementary radiator being in chaotic thermal movement at a temperature T is considered. The problem is solved in the framework of the quasi-classical approximation. The electromagnetic field is described by a plane monochromatic wave of wavelength λ and the elementary radiator is represented by a charged particle in a rectangular potential well of depth u and radius $a \ll \lambda$. To model the chaotic thermal movement, the wave function of the elementary radiator is multiplied by the wave function of the Gaussian wave packet. Its variance D , as it follows from the uncertainty principle, is:

$$D = L_d = (h / 2\pi) * (2 mkT)^{-1/2}, \quad (1)$$

where L_d is the thermal de Broglie length, h is the Planck's constant, m is the mass of the elementary radiator, k is the Boltzmann constant, T is the temperature of the solid matrix. The solution of the corresponding Schrödinger equation shows that there are two limiting regimes of interaction between the electromagnetic radiation and the solid matrix:

1. ($L_d \ll a$) This regime exists at sufficiently high temperatures when the variance D does not exceed the radius a and calculations of probabilities of radiation transitions can be executed in the long-wave approximation [1]. The probability of radiative transitions then equals 0 if the elementary radiator is at a node of the incoming electromagnetic wave and reaches its maximum if it is located at an antinode. It is shown that in this case the electromagnetic wave can induce stimulated emission only when the solid matrix is a regular crystal grating and only at those angles for which the condition of spatial synchronism is satisfied.

2. ($L_d \gg a$) The second regime occurs at sufficiently low temperatures of the matrix when D exceeds not only the typical dimensions of the elementary radiator, but also λ . In this case, the long-wave approximation is not applicable. However, calculations can be simplified by the substitution of the wave function of the elementary radiator with the product of the Gaussian wave packet and Dirac's delta function. In this regime, the incoming electromagnetic wave induces stimulated emission of the elementary radiator even in an irregular solid matrix and at any angle. The condition of spatial synchronism is satisfied here for all the excited elementary radiators. That results in cooperative superradiation the intensity of which q was calculated in [2] on the basis of a phenomenological consideration:

$$q = [f_M(T) * n * \text{Min}(x, 1/\mu) * \text{Min}(y, 1/\mu) * \text{Min}(z, 1/\mu)] / [(1 + \alpha_2)(\tau_2)(\Gamma_{\text{tot}})], \quad (2)$$

where f_M is the Mössbauer factor at the temperature T , n is the concentration of excited isomeric nuclei, τ_2 is the lifetime of the upper nuclear level, Γ_{tot} is the total width of the electromagnetic transition $2 \rightarrow 1$, α_2 is the conversion coefficient of the upper nuclear level, μ is the linear losses coefficient of the matrix at the wavelength λ , x, y, z are the linear dimensions of the solid matrix.

1. D. I. Blokhintsev, *Foundations of Quantum Mechanics*, 1976, Moscow, Nauka, p. 371 (in Russian)
2. G. A. Skorobogatov, B. E. Dzevitskii, *Laser Physics*, **5** (2), 258 (1995)

**FIRST OBSERVATION OF DOUBLE ESR - MÖSSBAUER RESONANCE
IN $\text{Al}(\text{NO}_3)_3 \cdot 9\text{H}_2\text{O} : ^{57}\text{Fe}(3+)$ SINGLE CRYSTAL IN REGIME OF
MIXED ELECTRON-NUCLEAR TRANSITIONS**

V. M. Cherepanov, M. A. Chuev, S. V. Gudenko, S. V. Kapelnitskii, S. S. Yakimov
Russian Research Center Kurchatov Institute, 123182 Moscow, Russia

Well-known methods such as ESR, NMR and Mössbauer Spectroscopy (MS) enable electronic or nuclear spin subsystems of paramagnetic atoms activating a diamagnetic host crystal to be studied separately. Also well-known are ENDOR and NMR-Mössbauer double resonance (DGMR) allow one to study interactions of the electronic and nuclear subsystems in the ground and excited nuclear states, respectively. Here, a new MS modification, ESR-Mössbauer double resonance (DGER), in the mode of the mixed electron-nuclear transitions is developed. The line-width and intensity changes for one of these transitions in aluminum nitrate crystal under ESR-pumping were found even at $T = 70$ K.

The possibility of performing double resonance experiments of type MS+NMR, MS+ESR or MS+optic resonance was discussed theoretically in [1], however, experimentally only the first one, DGMR=MS+NMR, was realized in a ferromagnet [2] and in paramagnetic nitrate aluminum, doped by ^{57}Fe , in [3]. As for the second one, DGER=MS+ESR, it was qualitatively considered in [1,4] and, depending on the amplitude of an alternating magnetic field H_a and relaxation times T_1 and T_2 , a changing of the Boltzmann population of the particular electronic level and corresponding perturbation of selected Mössbauer lines up to a total collapse of the magnetic hyperfine structure (HFS) were predicted. A common theory of DGMR and DGER was developed in [5] in the electron-nuclear state representation (in order to describe the cases where the effective field approximation is not applicable) which allows one to treat the quasienergetic structure of the perturbed Mössbauer spectrum similarly to the Rabi splitting known in optics [6]. Earlier, the only attempt to search for an influence of ESR-excitation on the Mössbauer spectra of aluminum alum crystal doped by ^{57}Fe was made in [7]. In the work, gamma-quanta count rate in the only one point of the most intensive line of the standard sextet of $^{57}\text{Fe}(3+)$, which in the crystal has an isotropic hyperfine interaction, at ESR conditions ($T = 2$ K, $P = 15$ mW, $F = 13.8$ GHz, $H_0 = 5.5$ kG - the case of the high external field for pure electronic $-5/2 - -3/2$ transitions) was measured and the very small intensity change about 0.10(6)% was found. This result may be understood in terms of Rabi splitting. From the theory of the double resonance follows [8], that the amplification factor K for the effective H_a in paramagnets is determined by the ratio H_{hf}/H_0 , where H_{hf} is the hyperfine field on ^{57}Fe nucleus. An estimation gives only $K \sim 100$ in the case of [7]. It is necessary to diminish the magnitude of H_0 and increase H_a for raising of a modulation index of the microwave pumping. Therefore, in our experiments, the complete Mössbauer spectra of 0.5% $^{57}\text{Fe}(3+)$ impurity in aluminum nitrate single crystal under ESR-excitation ($T = 70$ K, $P = 50$ mW, $F = 9.41$ GHz, $H_0 = 96$ G - the case of the weak external field) were measured. An X-band cylinder split cavity with a quartz helium flow cryostat inside was designed and a common setup complex on base of the Mössbauer LP-4900B and Bruker ESP-300 spectrometers was created for experiments on the double ESR-Mössbauer resonance. Earlier, aluminum nitrate doped with ferric ions was used as solid-state zero-field X-band (9.35 GHz) maser with 23.7 GHz pumping [9].

ESR spectra of the $7 \times 6 \times 2$ mm crystal with H_0 modulation up to 10 kG showed two crystallographic and two magnetic inequivalent sites with the rhombic crystal field parameters for the most intensive (93%) site1: $D_1 = 0.10(1) \text{ cm}^{-1}$, $I_1 = E_1/D_1 = 0.31(2)$. The ${}^6S_{5/2}$ ground state of the Fe(3+) ion in the crystal field is split into three Kramers doublets, one of which has an almost isotropic and two another ones have high anisotropic electronic g- and hyperfine A-tensors [10]. The total Mössbauer spectrum then consists of the three superposed spectra corresponding to each doublet. When the direction of H_0 is close to the plane where lie the smallest g, A-tensors components of one of the anisotropic doublet (in our case H_0 parallel to the c-axis of the crystal), intensive extra-lines lying far beyond the range of Doppler velocities typical for Fe(3+) were found [10]. The physical origin of this lines is as follows. In the weak magnetic field (respective to the crystal field Stark splitting about 1K in aluminum nitrate) the electronic Zeeman energy is comparable to the energy of the magnetic hyperfine interaction. In this case, both the ground and the excited nuclear states have a mixed electron-nuclear structure. If the nuclear transition alters the electronic state as well as the nuclear one, the Zeeman interaction may supply some of the energy needed for the transition. So far, aluminum nitrate is the unique substance where the transitions (so-called Z-lines) were clearly observed. Moreover, a detailed experimental and theoretical analysis revealed that Z-lines of appreciable intensity can be seen only owing to presence of randomly varying small magnetic fields $H_r \sim 1-10$ G, produced by magnetic moments of neighboring paramagnetic ions and nuclei [11]. These fields stabilize the energy position of the Z-lines, E, when the direction of H_0 is changed. They are also responsible for the rather complicated field dependence of E i.e. E is very sensitive to the value of H_0 . However, the Z-line intensity quickly decreases when H_0 increases and an optimum value of H_0 is about 100 G in order to see well-resolved intensive Z-lines under the condition $H_0 \gg H_r$. In terms of the hyperfine magnetic field the distance between the outermost Z-lines is equal to $H_{hf} = 750$ kG for which $K \sim 10^4$ is two order larger than in the case of [7] and an estimated value of Rabi splitting is comparable to the natural ${}^{57}\text{Fe}$ Mössbauer line-width, Γ_n . In fact, the ESR spectrum of aluminum nitrate has revealed a rather broaden line at $H_0 = 96$ G which was only partially saturated at $T = 70$ K. The Mössbauer spectra of the sample, measured in the DGER condition, revealed a marked widening of one of the Z-lines that allows the mixed electron-nuclear states to be used as more informative for studying DGER modulation effects as compared to the pure electron or pure nuclear states.

The work was supported by the Grant N 94-02-04785 of the Russian Foundation for Basic Researches.

- [1] C. P. Poole, Jr., H. A. Farach, J. Magn. Res. 1(1969)551
- [2] F. G. Vagizov, Hyperf. Interact. 61(1990)1363
- [3] S. S. Yakimov *et al.*, JETP Lett. 26(1977)13
- [4] I. B. Bersuker, S. A. Borshch, Phys. Stat. Sol. (b) 49(1972)K71
- [5] E. K. Sadykov, Phys. Stat. Sol. (b) 123(1984)703
- [6] A. Wannstrom *et al.*, Phys. Rev. A38(1988)5964
- [7] J. A. Lock, J. F. Reichert, J. Magn. Res. 7(1972)74
- [8] A. M. Afanas'ev *et al.*, Preprint IAE, N3337/9(1980), (in Russian)
- [9] W. E. Hughes, IEEE J. Quant. Electronics 2(1966)233
- [10] A. M. Afanas'ev *et al.*, Hyperf. Interact. 11(1981)141
- [11] A. M. Afanas'ev *et al.*, Sov. Phys. JETP 62(1985)104

QUANTUM BEAT SPECTROSCOPY OF MODULATION HARMONICS IN GAMMA MAGNETIC RESONANCE

A. V. Mitin

Kazan Branch of Moscow Power Engineering Institute, Krasnoselskaja street 51,
Kazan 420066, Russia

Abstract. The spectral analysis of temporal harmonics due to modulations of pumping rf or static magnetic fields under the excitation of gamma magnetic resonance is carried out. Coherent features of harmonics, which are promoted to the enhancement of gamma radiation, and schemes for their realization are considered. The study of inhomogeneous broadening effects occupies a special place. The consideration has shown that the analysis of harmonic spectra may be used for reconstruction of the hyperfine field distribution function in irregular solids.

In the present time the observation of gamma magnetic resonance (GMR) in irregular solids is a rather difficult problem. The reason is that the radiofrequency (rf) magnetic field intensity (in frequency units) must be compared with the inhomogeneous spectral width. The last condition requires too big rf magnetic field. However the nonlinear character of GMR effect enables to determine a hyperfine structures of nuclear sublevels and in the case of a considerable broadening [1, 2]. So the rf scanning of GMR spectra may be used for the obtaining of spectral lines with natural widths [2]. For this purpose besides the strong transverse rf field H_1 the trial transverse frequency scanning field H_2 is applied. The gamma radiation from a Mössbauer source has a natural line width Γ and it interacts only a small part of the nuclei which have a spectral inhomogeneous broadening $\delta \gg \Gamma$. The strong field H_1 forms the effective field on the nucleus. Then the frequency of the field H_1 is resonant only for a special nuclear spin packet and the frequency scanning field H_2 enables one to detect this packet. But the GMR rf scanning is rather difficult in technical aspects. Another decision of this problem was put recently with the help of the quantum beat method. The performance of the quantum beat gamma radiation method, stimulated by ultrasonic (US) Doppler modulation (high measurement precision of spectral shifts synchronous detection technique) [3], attracted attention to this method. However US modulation is the parametric process and so it can not be used for a resolving of inhomogeneously broadened spectral lines.

GMR – induced quantum beats were considered earlier by us [4]. However too high harmonic frequencies, due to resonance nuclear Zeeman frequencies for ^{57}Fe in soft magnetic ferromagnets, prevented others [3, 5] to observe them. Then we began to study GMR quantum beats which arose by two temporal modulations: the rf pumping magnetic field amplitude modulation and the static magnetic field modulation [6]. The transmission modulation intensity on Ω_2 frequency ($\Omega_2 \ll \Omega_1$, where Ω_1 is the pumping frequency) may be written in the following form:

$$P \sim + \sum_{n=0}^{\infty} \text{Re} \{ \chi_n e^{in(\Omega_2 t + \varphi_2)} \}.$$

Here $\chi_n = \chi'_n + i\chi''_n$ depend strongly on operator factors $\hat{I}_e^x(\beta e) = \hat{I}_e^x \cos \beta e + \hat{I}_e^z \sin \beta e$ or $\hat{I}_e^z(\beta e) = \hat{I}_e^z \cos \beta e + \hat{I}_e^x \sin \beta e$; \hat{I}_e^x, \hat{I}_e^z are nuclear spin operators of excited nuclear state; βe is the effective angle [7]. Under $\beta e \ll \pi/2$ the first modulation variant is the Raman process, the second one is the parametric process. Doppler velocity spectra under the first variant consist of

narrow lines of Lorentz shape actually under the strong inhomogeneous broadening. Spectral lines under the second variant have a dispersed shape and they are broadened by the inhomogeneous spread. The situation is different when the pumping field is increased ($\beta e \geq \pi/2$). In this case parametric and Raman processes are mixed and spectral lines became sharper for the second modulation variant [6]. It may be shown that odd harmonics χ_n approximately exchange a sign under the reversion of GMR resonance detuning (Fig.1). This property is analogous to US Doppler modulation [8]. Reversion features of odd harmonics in the realization of gamma radiation enhancement are considered. The Fig.2 demonstrates the dependence of the frequency integrated module intensity of the second harmonic on hyperfine field H_{hf} in comparison with the distribution function in an amorphous metallic alloy. It is seen that harmonic integrated module intensity are selective to H_{hf} and the dependence has the multi-resonance character. With the help of GMR resonance detuning one can choose the local packet of Mössbauer nuclei and thus one can reconstruct hyperfine field distribution function (Fig.3). The extensive analysis of GMR modulation harmonic spectra in amorphous metallic alloys and zinc-nickel ferrites is given.

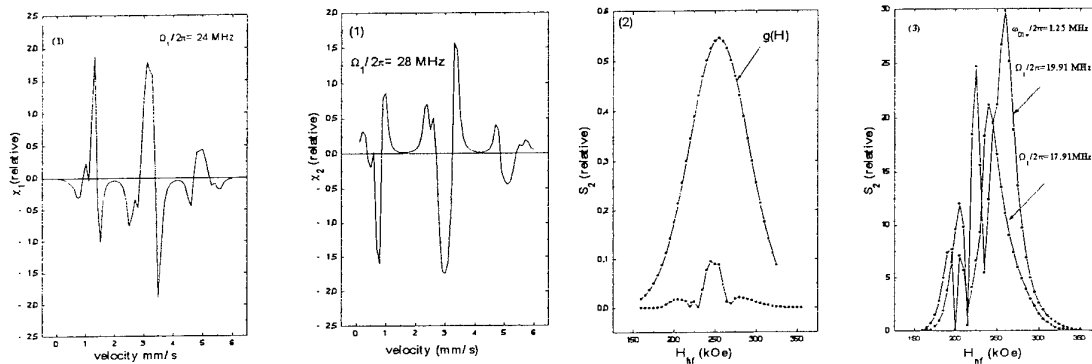

Fig. 1. The reversion of harmonic spectra ^{57}Fe in iron $\omega_e / 2\pi = 26$ MHz, $\omega_{1e} / 2\pi = 2.5$ MHz

Figs. 2, 3. Harmonic intensity distributions in amorphous metallic alloy ($|\omega_e|/2\pi=19.91$ MHz, $\sigma = 36.6$ kOe, $g(H)$ is Gaussian curve).

This work was supported by the Russian Foundation for Fundamental Research (project no. 97-02-17366).

1. A. V. Mitin and N. V. Polyakov, Phys. Lett. A114 (1986) 27
2. A. V. Mitin, E. F. Makarov, and N. V. Polyakov, Sov. Phys. JETP 63 (1986) 359
3. G. J. Perlow, Phys. Rev. Lett. 40 (1978) 896
4. A. V. Mitin, Phys. Lett. A84 (1981) 278
5. M. Lippmaa, I. Tittonen, J. Lindon, and T. Katila, Phys. Rev. B52 (1995) 10268
6. A. V. Mitin, Phys. Lett. A213 (1996) 207
7. A. V. Mitin, Izvestiy RAN (Ser. Phys.) 56 (1992) 186
8. J. E. Monahan and G. J. Perlow, Phys. Rev. A20 (1979) 1499

ABOUT SONOLUMINESCENCE EFFECT AS A POSSIBLE WAY OF GAMMA-RAY LASER PUMPING

S. A. Moiseev *, A. A. Aganin **

* E. K. Zavoiskii Kazan Physical-Technical Institute,
Kazan Science Center, Russian Academy of Sciences,
10/7 Sibirskii Trakt, Kazan, 420029, Russia

** Institute of Mechanics and Machinery,
the Russian Academy of Sciences,
2/31 Lobachevsky str., Kazan, 420111, Russia

Abstract. Attention is drawn to the effect of single bubble sonoluminescence as a new possible method of excitation of high nuclear levels. Some aspects of this effect are discussed in connection with their perspective use in solving the problem of nuclear gamma-ray laser pumping.

One of the most important problems in the development of gamma-laser is the experimental realization of nuclear pumping of high energy levels [1, 2]. The optimum solution to this problem cannot be recognized [2]. New variants of pumping for various nuclei are being put forward. To this end, powerful energy sources, X-rays, neutron fluxes, high temperatures are proposed. In the same time, the pumping must not destroy the very strict conditions of lasing initiation. These two important demands are in strong contrast to each other and dictate extreme conditions for gamma-laser realization, creating complex physical and experimental problems. A promising way of gamma-laser development is related to separation, in time and space, of problems of heating, pumping and lasing [3]. This way, the extreme physical conditions must be preserved during a short period of time. In this presentation, attention is drawn to the single bubble sonoluminescence effect as a new experimental possibility of creation of extreme physical state of medium, satisfying conditions of pumping for nuclear gamma transitions.

The single bubble sonoluminescence effect consists in what follows. A gas bubble of 1-5 μm diameter and the surrounding liquid at room temperature are in a field of standing ultra-sound wave. During every period of sound oscillations, the bubble first grows up many times in size and then, with great speed, collapses. In the final stage of the collapse, a shock is formed inside the gas medium, propagating to the bubble center [4]. Approaching the center, its velocity increases rapidly, becoming much higher than sound speed. The matter behind the shock moves to the center so fast that its following braking results in the extreme state of the matter are accompanied by a short (~ 50 ps) pulse of light [5]. According to the published data [6], the pressure in the center of the bubble attain values of the order of 1 Mbar and temperatures of 0.1 MK. Physical processes inside the bubble are at present actively investigated.

Even the temperatures obtained now in experiments allows one to consider the sonoluminescence effect as an alternative way of excitation of nuclear transitions with energies of the order of 1-10 keV. In this respect, it is interesting to try to obtain single bubble sonopumping of well-studied nuclear transitions of the iron ^{57}Fe . Thanks to the small duration of light emission and the relatively large lifetime of excited nuclei of ^{57}Fe , the detection of gamma quanta is significantly simplified. The possibility of chemical composition control is demonstrated by existing experiments [7] where the influence of a percentage of noble-gases (Ne, Ar, Kr), purposely introduced in the bubble, is investigated. In the same time, it should be noted that the introduction of heavy atoms into the bubble will need solving some additional problems, one of which being the choice of chemical composition, optimal for nuclear pumping realization.

A curious feature of sonoluminescence consists in the fact that lowering the temperature of laboratory conditions from the room level to the freezing point significantly increases the maximum collapse temperatures [8]. One of the explanations for this feature is related to the temperature variation of gas concentration in the bubble [9]. In such a case, the choice of chemical composition will be essentially dependent on the temperature regime of sonoluminescence. The role of temperature is not restricted by its influence on the chemical composition in the bubble. Temperature heating can contribute to the shock front stabilization or to its excessive smearing at the moment of collapse. Another way to control the energetics of sound energy transformation into internal degrees of freedom can be based on the use of dynamic regularities of energy transformation. In the shock wave focusing, a significant portion of energy is consumed by ionization and other intra-atomic and molecular processes. This influences the dynamics of collapse and determines the attainable maximum temperature. To increase the temperature, one can try to rapidly pump additional energy into the atomic system moving behind the shock, using contemporary broad-band femtosecond lasers.

For the effect under consideration, the extreme states of matter presently attained are not the limit. Attempts to obtain higher temperatures and pressures in the bubble are being continued. According to theoretical estimates [9], the temperature can be increased to tens of millions degrees, for example, by increasing acoustic pressure in the sound wave to 1.4-1.5 bar while bubble dynamics in acoustic field remains stable. The attainment of such temperatures will make possible to perform pumping of nuclear levels at room conditions with transition energy in the range of 0.1-1 MeV.

Clearly, the influence of magnetic field should be investigated in order to efficiently use the effect under consideration for pumping nuclear transitions under conditions of high degree ionization of atoms, first of all in the sense of bubble dynamics stabilization in the course of its collapse. The magnetic field can be generated by external stationary and impulse sources. Spontaneous formation of strong impulse magnetic fields in the course of bubble collapse is not improbable, especially under conditions of its preliminary magnetization.

As a conclusion, it should be noted that problems of sonopumping are of synergetic character. They require taking into account coordinated course of many physical processes in a wide range of variation on temporal and spatial scales. Their solution can be found only by using a theoretical description based on models of macro and micro levels.

1. C. B. Collins and J. J. Carroll, *Laser Physics* **5**, 209 (1995)
2. G. C. Baldwin and J. C. Solem, *Laser Physics* **5**, 231 (1995)
3. S. V. Karyagin, *Laser Physics*, **5**, 343 (1995)
4. C. C. Wu, P. H. Roberts, *Phys. Rev. Lett.* **70**, 3424 (1993)
5. B. P. Barber and S. J. Putterman, *Nature* **352**, 318 (1991)
6. B. P. Barber, C. C. Wu, R. Lofstedt, P. H. Roberts, and S. J. Putterman, *Phys. Rev. Lett.* **72**, 1380 (1994)
7. R. Hiller, K. Weninger, S. J. Putterman, and B. P. Barber, *Science* **266**, 248 (1994)
8. R. Hiller, S. J. Putterman, B. P. Barber, *Phys.Rev.Lett.* **69**, 1182 (1992)
9. L. Kondic, J. I. Gersten and C. Yuan, *Phys.Rev.E.* **52**, 4976 (1995)

TEMPORAL PROPERTIES OF THE QUANTUM COLLAPSE AT THE COHERENT INTERACTION OF THE PHOTON WITH RESONANT NUCLEAR SYSTEM

S. A. Moiseev

E. K. Zavoiskii Kazan Physical-Technical Institute,
Kazan, Science Center, Russian Academy of Sciences,
10/7 Sibirskii Trakt, Kazan, 420029, Russia

Abstract. Using the quantum electrodynamic approach a theoretical study of the temporal field's effects is performed for the time-delay coherent interaction of photons with Mössbauer nuclear system. The role and influence of irreversible processes on the coherent interaction are investigated. The visual method is proposed for the study of quantum collapse dynamics at the time-delay interaction.

The fundamental property of the quantum field is connected with the formation of the interrupted (collapsed) behavior in the continuing evolution. In the beginning of the laser irradiation the field contains a small number of lasing photons and the quantum properties of the field represent the main source of the lasing fluctuations. In the following evolution these fluctuations can increase essentially, so the quantum nature of the weak pulsed quantum (WPQ-) fields would determine the temporal properties and fluctuations of the macroscopic intensive fields. This effect takes place at the pulse generation in the Dicke optical superradiance and induced Raman effects [1, 2]. With respect to the optical region, in the gamma region the energy of the photon is very large, so the role of the quantum properties of the WPQ- fields will be more significant. The study of the temporal coherent and quantum behavior is interesting both for the gamma-ray laser problem, and from a more general point of view, for the understanding of the quantum interaction's nature, namely the quantum theory can reflect more fundamental unusual quantum laws than the classical theory in the macroscopic temporal tasks [3]. In the present work these questions are analyzed at the time delay interaction of the photon with resonant nuclei. The Hamiltonian of the model is:

$$\begin{aligned}
 H &= H_a + H_f + V, H_a = \sum_{j=1}^N \sum_{n=1}^3 [E_n^j + \delta E_n^j(t)] \hat{P}_{nm}^j, H_f = \int_{-\infty}^{\infty} d^3k \hbar \omega_k \hat{a}_k^+ \hat{a}_k, \\
 &= \hbar \sum_{j=1}^N \sum_{n>m}^3 \int d^3k \{ \hat{P}_{mn}^j \hat{a}_k g_{mn}^j(k) e^{ikr} + \hat{P}_{nm}^j \hat{a}_k^+ g_{nm}^j(k) e^{-ikr} \}.
 \end{aligned}
 \tag{1}$$

Nuclei operators: $\hat{P}_m^j = |n_j\rangle\langle m_j|$, $g_{nm}^j(k)$ - the constants of the interaction. The functions $\delta E_n^j(t)$ model the influence of random processes determining the irreversible behavior of the system. The Mössbauer nuclei are considered at three level approximation with energies: $E_3^j > E_2^j > E_1^j$. The transition $|1\rangle \leftrightarrow |2\rangle$ is a gamma transition, the frequency $|2\rangle \leftrightarrow |3\rangle$ is an optical transition.

The gamma photon propagates to the medium in the regime of time-delay interaction [4-5] along two different spatial directions k_1 and k_2 , as it can be done in Mössbauer diffraction [6, 7]. The photon is at resonance with the transition $|1\rangle \leftrightarrow |2\rangle$ of the nuclei. Before the interaction the total wave function is:

$$|\Psi_{in}(-\infty)\rangle = \frac{1}{\sqrt{2}} \int d^3k [F(k - k_1) e^{-i\omega_k \tau} + F(k - k_2)] \hat{a}_k^+ |0\rangle \otimes \prod_j |1_j\rangle
 \tag{2}$$

The coherent interaction leads to the formation of single nuclear collective excitation in the form of the spatial grating described by the density matrix [8-10]:

$$\hat{\rho}_a(t) = |\Psi_a(t)\rangle\langle\Psi_a(t)| = \hat{\rho}_{a,a}(t) + \hat{\rho}_{a,22}(t), \hat{\rho}_{a,a}(t) = \sum_i \sum_{j \neq i}^N \beta_j^*(t) \hat{P}_{21}^j \hat{P}_v \hat{P}_{12}^j, \quad (3)$$

$$\hat{\rho}_{a,22}(t) = \sum_{j=1}^N \hat{P}^j |\beta_j(t)|^2 \hat{\rho}_v(j); \hat{\rho}_v(j) = \prod_{n \neq j}^N \oplus |I_n\rangle\langle I_n| \oplus |0\rangle\langle 0|; |0B\rangle = \prod_n^N \oplus |I_n\rangle \oplus |0\rangle.$$

The density matrix (3) will be transformed into the diagonal form ($\hat{\rho}_a(t) \rightarrow \hat{\rho}_{a,22}(t)$), as irreversible processes of phase relaxation will be realized. This transformation is performed at the time T_r (time of collapse) which is determined by the phase memory time T_2 . According to the existing quantum mechanics interpretation the transformation is connected with the instantaneous collapse of the wave function at some random moment of time. Thus, the spatial delocalized wave function will transform into a new physical state where the excitation will be localized at one of the nuclei. At present the reasons of the collapse are connected only with the destruction of coherent behavior of the wave function. In the same time any mechanisms of this collapse are unknown. Thus, the favorable situation for the study of this fundamental quantum collapse phenomenon appears at the single photon field interaction, where the quantum properties are considerably visible.

This temporal picture of the quantum collapse can be experimentally detected, if the excited spatial grating in the nuclei system will be read out by the additional field. The most favorable case will appear if the frequency of the additional field is at resonance with the optical transition $|2\rangle \leftrightarrow |3\rangle$. When the grating exists, the additional field will lead to the scattering field, or the single photon echo (the most favorable case for detection) propagating only in a certain spatial direction in accordance with phase matching $k = k_s + k_2 - k_1$ and at a fixed moment of time. When the collapse will destroy the nuclei excited grating this phase matching will destroy instantaneously, so the echo signal or the scattering field will disappear. By the realization of this interaction at different moments of time we will have the method of visualization for the temporal properties of spatial collapse in delocalized quantum nuclei system.

The experimental study of this temporal quantum phenomenon can provide the intimate information about the quantum nature of the photon and its interaction with nuclei system, about the quantum sources of fluctuations. The detection of the effect can be realized at the accumulation of single events connected with different single photon tasks as at the detecting of muon spin echo [11].

This work was supported by the international fund USAF EOARD, grant no. F61708-96-W0198.

1. Q. H. F. Vreken, der J. J. Weduwe, Phys. Rev. A **24**, 2857 (1981)
2. S. A. Akhmanov, Yu. E. Diyakov, A. S. Chirkin, *Introduction in statistic radiophysics and optics*, Moscow, Nauka, 1981, 580p (in russian)
3. L. A. Khalfin, Physics-Uspechi **6**, 688 (1996)
4. A. R. Kessel, S. A. Moiseev, JETP. Lett. **58**, 80 (1993)
5. S. A. Moiseev, Hyperfine Interactions, 00.0303, 1996 (in press)
6. G. V. Smirnov, Yu. V. Shvydko, Let. in JETP **39**, 33 (1984)
7. E. A. Popov, Phys. Stat. Sol. (a) **127**, 207 (1991)
8. S. A. Moiseev, N. L. Nevelskaya, E. I. Shtyrkov, Opt. and Spect. **79**, 382 (1995)
9. S. A. Moiseev, Opt. and Spect., 1997 (in press)
10. S. A. Moiseev, Opt. and Spect., 1997 (in press)
11. S. A. Moiseev, N. M. Suleimanov, JETP Lett. **64**, 544 (1996)

**THE COHERENT REPOPULATION OF HYPERFINE LEVELS
AND INDUCED GAMMA EMISSION**

D. F. Zaretsky and S. B. Sazonov

Russian Research Center "Kurchatov Institute", Moscow, Russia

The coherent repopulation of hyperfine levels by a dichromatic resonance rf-wave is investigated theoretically. A three-level nonequidistant atomic system is supposed to be in resonance with the dichromatic rf-field. The repopulation is due to the interference of two population amplitudes arising from the two components of the rf-wave on the common level. This effect is analogous to the well-known population trapping in optics. It is shown that, in the pulsed rf-field when the pulses duration is less than all the relaxation times, the repopulation takes place even in the case of initially equally populated levels.

The coherent repopulation may be effective in the case of room temperature. Therefore, this effect opens the way for the investigation of induced gamma transition and anomalous transparency of resonance media.

INDUCED EMISSION OF GAMMA RADIATION FROM ISOMERIC NUCLEI**Silviu Olariu and Agata Olariu**

Institute of Physics and Nuclear Engineering,

Department of Atomic and Nuclear Physics

76900 Magurele, P.O. Box MG-6, Bucharest, Romania

In a recent work it has been shown that the lifetime of isomeric nuclear states can be influenced by X-ray electron-nuclear double transitions (XENDT's), which are processes in which a transition effected by an inner atomic electron takes place simultaneously with a nuclear electromagnetic transition [1]. The rate of deexcitation of isomeric nuclei induced by XENDT's was calculated for the case when the holes in the atomic shells are produced by incident ionizing electrons and it was found that the induced nuclear deexcitation rate becomes comparable to the natural decay rate for ionizing fluxes of the order of 10^{14} W cm⁻².

In this work we study the possibility to influence the lifetime of nuclear isomeric states with the aid of incident fluxes of photons. The induced deexcitation of the isomeric nucleus considered in this work is a two-step process. We assume that the nucleus initially in the isomeric state $|i\rangle$ first absorbs a photon of energy E_{ni} so that the nucleus reaches the higher intermediate state $|n\rangle$. The state $|n\rangle$ then decays to a lower state $|l\rangle$ by the emission of a gamma-ray photon having the energy E_{nl} .

We estimate the incident spectral intensities for which the single-photon induced emission rates become equal to the isomeric decay rates. These single-photon intensities turn out to be exceedingly large. We discuss the concept of two-step deexcitation of isomeric nuclei induced by incident photon fluxes, and estimate the incident spectral intensities for which the two-step induced emission rates become equal to the isomeric decay rates. We list the nuclear isomers for which the required incident power density may be within the reach of existing experimental techniques. In favorable cases the two-step induced emission rates become equal to the isomeric decay rates for incident power densities of the order of 10^{10} W cm⁻². If E_{nl} or the energy of one of the gamma-ray transitions associated to the decay of the state $|l\rangle$ is substantially larger than E_{ni} , the two-step induced emission may be regarded as an upconversion process, although the required incident power densities turn out to be in general larger in the latter case.

1. S. Olariu, A. Olariu and V. Zoran, Phys. Rev. C **56**, 381 (1997)

EMISSION OF GAMMA RAYS BY X-RAY ELECTRON-NUCLEAR DOUBLE TRANSITIONS

Silviu Olariu, Agata Olariu and Valeriu Zoran

Institute of Physics and Nuclear Engineering,

Department of Atomic and Nuclear Physics

76900 Magurele, P.O. Box MG-6, Bucharest, Romania

In this work we give expressions for the cross sections of electric and magnetic X-ray electron-nuclear double transitions (XENDT's), and study the application of these processes to the problem of induced gamma emission. If the nucleus is initially in a long-lived isomeric state $|i\rangle$, the electron-nuclear transitions open a new deexcitation channel for the isomeric state, in addition to the regular gamma-ray emission and internal conversion. One possibility is the direct deexcitation of the isomeric nucleus by a transition from the isomeric state $|i\rangle$ to a lower state $|l\rangle$, while an electron is raised to fill a hole in a higher electron shell. Another possibility is the two-step deexcitation of the isomeric nucleus by a transition from the isomeric state $|i\rangle$ to a higher nuclear state $|h\rangle$ while an electron from a higher shell makes a transition to a hole in an inner electron shell. The nuclear intermediate state $|h\rangle$ then decays by the emission of a gamma-ray photon to the lower nuclear state $|l\rangle$.

We calculate [1] the probability of an X-ray electron-nuclear double transition for electric or magnetic interactions of arbitrary multipole orders, and estimate the cross section for the production of these transitions for the case when the holes in the atomic shells are produced by incident ionizing electrons. We also estimate the ionizing electron fluxes for which the rate of the XENDT process becomes equal to the natural decay rate of the isomeric state, both for a direct deexcitation $|i\rangle \rightarrow |l\rangle$ and for a two-step deexcitation $|i\rangle \rightarrow |h\rangle \rightarrow |l\rangle$, and find that the induced nuclear deexcitation rate becomes comparable to the natural decay rate for ionizing fluxes of the order of $10^{14} \text{ W cm}^{-2}$. We show that for E1 and M1 nuclear processes for which there is a matching between the electron and the nuclear transition energies, the XENDT's can be used to produce pulses of Mössbauer radiation, with yields of the order of 10^4 Bq mA^{-1} .

1. S. Olariu, A. Olariu and V. Zoran, Phys. Rev. C **56**, 381 (1997)

SINGLE PARTICLE STRUCTURE OF HIGH-K ISOMERS IN A~178-180 NUCLEI

P. Quentin, J. Libert, N. Pillet and A. Pons

CENBG (IN2P3-CNRS and Univ. Bordeaux-I), BP 120

33170 Gradignan-cedex, France

In the region of nuclei with A~178-180, there are many rather well documented high-K isomers, for instance: 8^- (4 s), 16^+ (31 yr), 14^- (68 μ s) in ^{178}Hf , $25/2^-$ (25.1 d) in ^{179}Hf and 9^- ($1.2 \cdot 10^{15}$ yr) in ^{180}Ta . On the other hand, self-consistent calculations using the Skyrme SIII interaction plus a simple pairing interaction (whose strength is fixed on odd-even mass differences apart from a ~10% strength reduction due to obvious collective vibration effects) have been shown to well reproduce the collective spectrum and at the same time the isomeric 16^+ state in ^{178}Hf [1]. We extend here the above quoted approach to perform a systematic study of high-K isomers in this region and to draw conclusions both on the spectroscopic properties of states in the high-K part of the spectra and on possible specific low-lying "gateways" for the decay out of long-lived isomeric states, as suggested experimentally in the "tantalizing" case of ^{178}Hf [2].

The whole spectroscopy of the considered high-K isomers is governed by three neutron ($5/2^-$, $7/2^-$, $9/2^+$) and two proton ($7/2^+$, $9/2^-$) quasi-particle states. The quality of our calculated single-particle spectra is assessed by the perfect reproduction (within the approximation of independent many quasi-particle states over the ^{178}Hf BCS vacuum) of the isomeric energies of the 16^+ , 14^- , $25/2^-$ and 9^- states in the relevant isotopes (see table).

Taking stock of this excellent reproduction of existing data, one can proceed with some predictions. Firstly, one expects a very rich spectroscopy of high-K band heads due to the possible combinations of many low-lying high-K single-particle orbitals. Of paramount importance is the quasi-degeneracy of a $K^\pi = 15^+$ configuration with the well-studied $K^\pi = 16^+$ configuration (the former amounting to replace by a $5/2^-$ neutron state the $7/2^-$ appearing in the latter). If confirmed, this fact could yield amusing consequences on the spectroscopy of states lying above the $I^\pi = 16^+$ isomeric state in ^{178}Hf , as well as on the mere structure of this isomer which might appear far more complicated than expected. Let us discuss now the "gateway" states for the deexcitation of the 16^+ isomer. Much below 1 MeV (above the isomeric state) there are some isolated states which may well be reached by parity changing (e.g. E1) or not transitions and which are likely to present some Coriolis admixture of $K = 15, 14, 13, \dots$ configurations. At 2 MeV and above it

seems inescapable that quite a lot of such states should be available. All the conclusions drawn from these results are however to be mitigated by the present rather crude approximation in use (independent many quasi-particle states above the same vacuum). The quantitative effects of Coriolis coupling, of pairing gap decrease upon increasing the quasi-particle number, of Hartree-Fock polarization (both time-even and time-odd) and of residual quasi-particle interactions (see [3]) are currently investigated.

State	Nucleus	s.p. structure		E th. (MeV)	E exp. (MeV)
16^+	^{178}Hf	$n7/2^-, n9/2^+$	$p7/2^+, p9/2^-$	2.47	2.45
14^-	^{178}Hf	$n5/2^-, n7/2^-$	$p7/2^+, p9/2^-$	2.66	2.57
$25/2^-$	^{179}Hf	$n9/2^+$	$p7/2^+, p9/2^-$	1.18	1.06
9^-	^{180}Ta	$n9/2^+$	$p9/2^-$	0.04	0.07

1. P. Quentin, S. J. Krieger, J. Libert and M. S. Weiss, in *Nucl. Shapes and Nucl. Structure at Low Excitation Energies*, M. Vergnes *et al.* eds. (Plenum, New York, 1992), p. 163
2. C. B. Collins *et al.*, Phys. Rev. **37** (1988) 2267
3. L. Bennour, J. Libert, M. Meyer and P. Quentin, Nucl. Phys. **A465** (1987) 35

NUCLEAR NON-AXIAL EXCITATIONS AND K-MIXING STATES*

L.J.Zhu, Z.S.Yuan, Z.Y.Pan and Y.K.Ho

Department of Physics II, Fudan University, Shanghai, 200433, P.R.China

Abstract

This paper with convincing calculations indicates that a non-axial symmetric nuclear excitation level is a K-mixing state, which can serve as an intermediate state substantially speeding the depopulation of long-lived isomeric states.

The research on the feasibility of a gamma-laser has recently drawn much attention on the two step pumping scheme[1] involving a K-mixing level as the intermediate state to depopulate the long-lived isomeric states, for instance, the isomer $^{178}\text{Hf}^{m2}$ with $T_{1/2} = 31y$, $E_x = 2.45\text{MeV}$, $16^+(K = 16)$. The critical problem along this line is to find out appropriate K-mixing states. In this paper, we suggest that nuclear non-axial symmetric excitation states, of which K, the projection of spin J on the axis of the nuclear body system, is no longer a good quantum number, may be the candidate for this K-mixing intermediate state.

We consider the triaxial ellipsoid-deformed excitations with nonvanishing γ values which characterize the non-axial symmetry. The corresponding Hamiltonian, known as a rigid- γ rotor model [2], is written as

$$H_{DF} = \frac{\hbar^2}{8B\beta^2} \sum_{\lambda=1}^3 \frac{I_{\lambda}^2}{\sin^2(\gamma - \frac{2}{3}\pi\lambda)} \quad (1)$$

The eigenvectors of H_{DF} can be obtained by diagonalizing Eq.1 in the basis states that are eigenfunctions of related axially symmetric rotor,

$$|IM\rangle = \sum_{K \leq I} A_{IK} |IMK\rangle \quad (2)$$

where the coefficients A_{IK} represent the magnitude of K-mixing.

To demonstrate the effect by introducing such γ -deformed levels as the intermediate states to depopulate isomers, we study the modeled nuclear levels shown in Fig.1 simulating the case of $^{178}\text{Hf}^{m2}$. Our task is to depopulate the isomer $J^{\pi} = 16^+$, $K = 16$ to the $K = 8^-$ band. The direct EM transition should be $M8$ or $E9$ due to the K-forbidden rule. As for the indirect transitions, we assume 16_7^+ state, obtained by solving Eq.1 and 2, serves as the intermediate state, which should have noticeable transition connections with both the $16^+(K = 16)$ state, serving as the storage level for gamma-laser, and the levels in the $K = 8^-$

* This work is supported by the National Natural Science Foundation of China.

band, one of them would work as the upper laser level. The optical pumping process for the transition $16^+(K=16) \rightarrow 16_7^+$ is expected to be very fast, and the EM transition from 16_7^+ to $14^-(K=8)$ can be expressed as:

$$T(EM, 16_7^+ \rightarrow 14^-(K=8)) = |A_{16,0}|^2 T(E9/M8) + \dots + |A_{16,6}|^2 T(E3/M2) + |A_{16,8}|^2 T(E3/M2) + |A_{16,10}|^2 T(E3/M2) + \dots + |A_{16,16}|^2 T(E9/M8) \quad (3)$$

Fig.2 presents the ratio of the indirect transition probability($16_7^+ \rightarrow 14^-(K=8)$) over the direct case ($16^+(K=16) \rightarrow 12^-(K=8)$). For simplicity and without losing any physics, we assume the energy spacings for the indirect transition and the direct are the same. The results clearly show that the indirect process via a gamma-deformed intermediate state can over the direct process by several orders of magnitude.

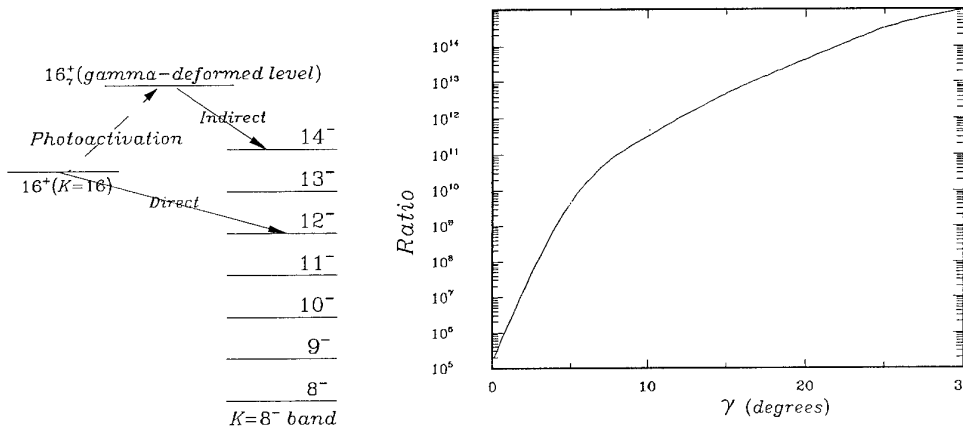

Fig.1 Modeled nuclear levels and two EM transition schemes for depopulating the isomer $16^+(K=16)$.

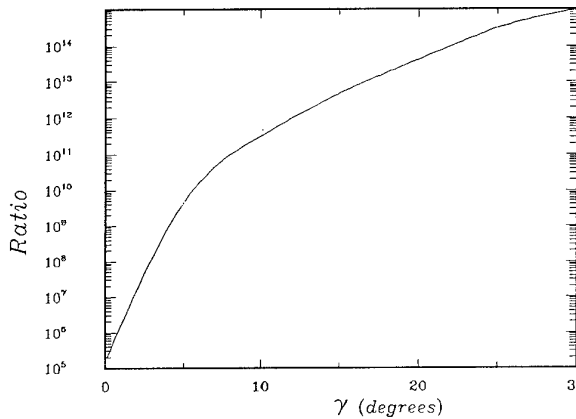

Fig.2 Comparison of the indirect transition via the gamma-deformed state and the direct case. The figure gives the ratio of $T(EM, 16_7^+ \rightarrow 12^-(K=8))$ over $T(E9/M8, 16^+(K=16) \rightarrow 14^-(K=16))$. Our calculation is based on the single-particle Weisskopf units and the energy spacings are assumed to be 1 MeV.

1. C. B. Collins et al., J. Appl. Phys. **53**, 4645 (1982)
C. B. Collins et al., Phys. Rev. **C 37**, 2267 (1988)
J. J. Carroll et al., Phys. Rev. **C 43**, 1238 (1991)
2. A. S. Davydov and G. F. Filippov, Nucl. Phys. **8**, 237 (1958)

INVERSIONLESS GAIN AT GAMMA-RAY TRANSITION VIA NUCLEAR COHERENCE CREATED BY OPTICAL DRIVING

Yuri Rostovtsev^{1,2}, Roman Kolesov¹, and Olga Kocharovskaya¹

¹Institute of Applied Physics, Russian Academy of Science, 46 Ulyanov str.,
603600 Nizhny Novgorod, Russia

² Department of Physics, Texas A& M University, College Station, TX 77843-4242, USA

A possibility of amplification without population inversion at γ -ray transition due to excitation of nuclear coherence via coherent optical driving of the electron coupled with nucleus is demonstrated.

Recently a new concept of lasing without inversion in atomic systems with a splitted operating level has been a subject of the intensive investigations [1]. A key idea of this concept is to reduce a resonant absorption at the operating optical transition due to excitation of the low-frequency atomic coherence at the transition between sublevels of the splitted level.

An extension of this concept to the γ -ray range (where it is difficult to achieve a population inversion) implies a search both for the appropriate structure of nuclear levels and for the ways of the nuclear coherence excitation. One option which we discuss in this paper is to use the hyperfine or Zeeman splitting of the operating levels driving by the resonant microwave field. Another possibility which we demonstrate here is an excitation of nuclear coherence transitions by means of optical driving. Such possibility is entirely due to interaction between nuclear and electronic degrees of the freedom.

One of particular physical models under consideration is as follows. We consider nuclei in the ground state having spin $I = 0$ and in one of its excited states with $I = 1$. For electron we consider ground state with angular momentum $J = 0$ and excited state with $J = 1$. The atomic excited state with excited nuclei is splitted into $F = 0, 1, 2$ states (hyperfine structure) due to interaction of the angular momentum of electron with a nuclear spin. The scheme of atomic levels is presented in Fig. 1. For simplicity, we restrict ourselves by the case of linear polarizations of both driving and probe fields when transition ($F = 1, M = 0$) \leftrightarrow ($F = 1, M = 0$) is forbidden by the selection rules.

The Hamiltonian of the system has the form $\hat{H} = \hat{H}_0 + \hat{V}$, where \hat{H}_0 is a Hamiltonian of free atom $\hat{H}_0 = \hbar\omega_1|1\rangle\langle 1| + \hbar\omega_2|2\rangle\langle 2| + \hbar\omega_3|3\rangle\langle 3| + \hbar\omega_4|4\rangle\langle 4| + \hbar\omega_5|5\rangle\langle 5|$. \hat{V} is a part of the Hamiltonian describing an interaction of atom with the driving and probe fields

$$\hat{V} = \Omega|1\rangle\langle 2| + \Omega_1|3\rangle\langle 4| + \Omega_2|3\rangle\langle 5| + \alpha|1\rangle\langle 2| + \alpha_1|2\rangle\langle 4| + \alpha_2|2\rangle\langle 5| + \text{c.c.},$$

where $\Omega_j = \mu_{ij}\mathcal{E}_{drive}/2\hbar$, $\alpha_j = \mu_{ij}\mathcal{E}_{probe}/2\hbar$, μ_{ij} is dipole matrix element between states i and j .

The density matrix equations for polarizations at γ -ray transitions are

$$\begin{aligned}\dot{\sigma}_{13} &= -\Gamma_{13}\sigma_{13} + in_{13}\alpha + i\sigma_{14}\Omega_1^* + i\sigma_{15}\Omega_2^* - i\Omega\sigma_{23} \\ \dot{\sigma}_{24} &= -\Gamma_{24}\sigma_{24} + in_{24}\alpha_1 - i\sigma_{14}\Omega^* + i\sigma_{23}\Omega_1 - i\alpha_2\sigma_{54} \\ \dot{\sigma}_{25} &= -\Gamma_{25}\sigma_{25} + in_{25}\alpha_2 - i\sigma_{15}\Omega^* + i\sigma_{23}\Omega_2 - i\alpha_1\sigma_{45},\end{aligned}$$

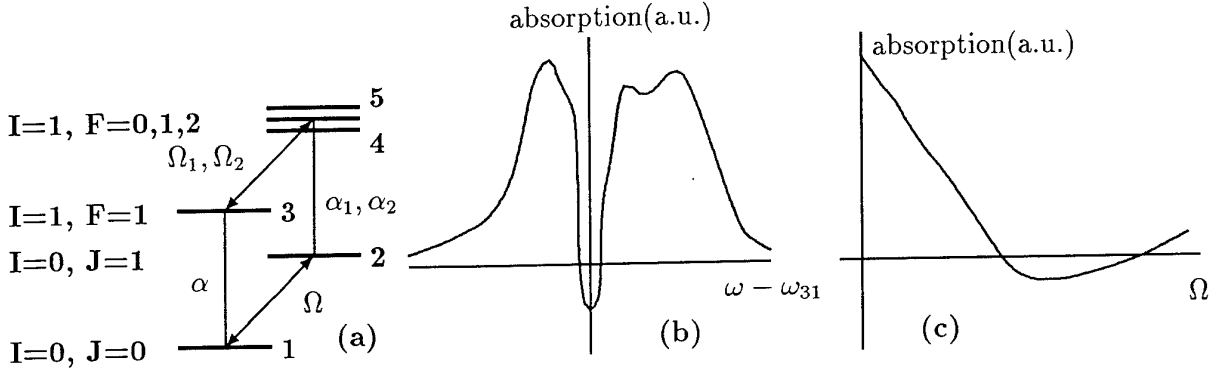

Figure 1: The scheme of atomic levels. The dependence of absorption/gain on detuning (a) and on Rabi frequency of optical driving field Ω (b)

where $\Gamma_{ij} = \gamma_{ij} + i(\omega - \omega_{ji})$, γ_{ij} is a relaxation rate of polarization for transition $i \leftrightarrow j$, $n_{ij} = n_i - n_j$ is a population difference between the states, i - and j . One has to add to this set of equations also the equations for coherences at the driven transitions as well as the equations for populations involving incoherent pumping.

We emphasize that an interaction between nucleus and electron plays a crucial role. If we neglect by the hyperfine splitting (taking $\omega_{21} = \omega_{43} = \omega_{53}$) we obtain the following equation for polarization $\mathcal{P} = \mu_{31}\sigma_{13} + \mu_{42}\sigma_{24} + \mu_{52}\sigma_{25} + \text{c.c.}$ at g -ray transition

$$\dot{\mathcal{P}} = -\Gamma_{13}\mu_{31}\sigma_{13} - \Gamma_{24}\mu_{42}\sigma_{24} - \Gamma_{25}\mu_{52}\sigma_{25} + \text{c.c.}$$

It consists of only relaxation terms and does not depend at all on the driving field. This means that there is no possibility to influence γ -ray transition by optical driving.

Such possibility appears due to interaction between the electron and nucleus when this interaction depends on parameters characterizing nucleus such as spin, size, deformation parameter, etc..

In Fig. 2 we present the dependence of the absorption coefficient for the formulated above physical model on the detuning and intensity of the driving field. This dependence is obtained by solving of the density matrix equations. It clearly indicates the possibility of inversionless gain at γ -ray transition. It is worth to note that there is some optimal value of the driving field intensity providing maximal value of the gain. Further increasing of the intensity effectively removes a hyperfine splitting. This leads to cancellation of low-frequency coherence contribution to polarization of γ -ray transition and as a result inversionless gain vanishes.

This work was supported by the IAP Programme of the Belgium government, Commission of the European Union DG III/ESPRIT Project CTIAC 21042, US Air Force (contract SPC-96-4031).

References

- [1] Kocharovskaya O., 1995, *Laser Physics*, **5**, 284; Zibrov, A.S., et al., 1995, *Phys. Rev. Lett.*, **75**, 1499; G.G.Padmabandu et al., 1996, *Phys. Rev. Lett.*, **76**, 2053.

THE THEORY OF CONTROLLING THE SPONTANEOUS NUCLEAR GAMMA-DECAY AND LIFETIME OF RADIOACTIVE AND EXCITED NUCLEI

V. I. Vysotskii

Kiev Shevchenko University, Radiophysical Dept., 252033, Kiev, Ukraine

Abstract. The general theory of controlling and changing the spontaneous nuclear gamma-decay was created. The phenomenon of nuclear decay controlling is a result of interaction of the excited nucleus with zero-energy electromagnetic modes, which in turn interact with the controlling screen. The strongest influence on the nucleus spontaneous decay process will be in the case when the electromagnetic field modes interaction with it in a zero-energy (the lowest by energy) state occur to be mutually synchronized.

For this case the increase of radiative life-time may be equals many orders. The problem of controlled radioactivity is one of the most interesting in nuclear physics. We have created the theory of resonant screen influence on the decay probability and life-time of excited and radioactive nuclei. We have considered the general system which included the excited atom nucleus (hamiltonian \hat{H}_A), the system of this atom electrons (\hat{H}_B), the system of zero-energy (in vacuum state) electromagnetic modes (\hat{H}_F) and the screen (\hat{H}_R) (the system of N resonant or non-resonant atoms) situated at the distance $L \gg \lambda_{eg}$ from the nucleus. The phenomenon of nucleus decay controlling is a result of interaction \hat{U} of the nucleus with zero-energy electromagnetic modes, of interaction $\hat{V} = \sum_{i=1}^N \hat{V}^{(i)}$ of these modes with the atoms of screen, and of

interaction \hat{T} of the nucleus with electrons system. The Schrödinger equation for the general system has the form: $i \hbar \partial \Psi / \partial t = \hat{H} \Psi$. Here $\hat{H} = \hat{H}_A + \hat{H}_F + \hat{H}_E + \hat{H}_R + \hat{U} + \hat{T} + \hat{V}$ - total hamiltonian of the general system,

$$\Psi(r, t) = A(t) \Psi_{a000}(r) \exp(-E_a t / \hbar) + \sum_{\alpha} F_{\alpha}(t) \Psi_{0\alpha 00}(r) \exp(-i E_{\alpha} t / \hbar) +$$

$$\sum_e E_e(t) \Psi_{00e0}(r) \exp(-i E_e t / \hbar) + \sum_n R_n(t) \Psi_{000n}(r) \exp(-i E_n t / \hbar)$$

-total wave function of the

general system; Ψ_{a000} , $\Psi_{0\alpha 00}$, Ψ_{00e0} and Ψ_{000n} -wave functions of the general system for cases of excited nucleus (excited energy $E_a = \hbar \omega_a$), excited mode $\{\alpha\}$ (excited energy $E_{\alpha} = \hbar \omega_{\alpha}$), excited electrons system state $\{e\}$ and excited screen state $\{n\}$ (excited energy $E_n = \hbar \omega_n$), correspondingly.

The dynamics of spontaneous decay of the excited nucleus is described by the system of equations

$$i \hbar \exp(-i \omega_a t) dA / dt = \sum_{\alpha} F_{\alpha} U_{\alpha a} \exp(-i \omega_{\alpha} t) + \sum_e E_e T_{ae} \exp(-i \omega_e t) + i \hbar \delta(t)$$

$$i \hbar \exp(-i \omega_{\alpha} t) dF_{\alpha} / dt = A U_{\alpha a}^* \exp(-i \omega_a t) + \sum_n R_n V_{n\alpha} \exp(-i \omega_n t)$$

$$i \hbar \exp(-i \omega_n t) dR_n / dt = \sum_{\alpha} F_{\alpha} V_{n\alpha} \exp(-i \omega_{\alpha} t)$$

$$i \hbar \exp(-i \omega_e t) dE_e / dt = A T_{ae}^* \exp(-i \omega_e t)$$

We have obtained the general solution of this system

$$A = (2\pi i)^{-1} \int_{-\infty}^{\infty} \exp(i \omega t) d\omega / \left\{ \omega - \sum_e |T_{ae}|^2 / \hbar^2 (\omega_e - \omega_a + \omega) - \right.$$

$$\left. \sum_{\alpha} |U_{\alpha a}|^2 / \hbar^2 [\omega_{\alpha} - \omega_a + \omega - \sum_n |V_{n\alpha}|^2 / \hbar^2 (\omega_n - \omega_a + \omega)] \right\}$$

Here $U_{\alpha a} = (2\pi \hbar \omega_{\alpha} / V_{0\alpha})^{1/2} (d_{eg} e_{\alpha}) \exp[-i(k_{\alpha} r_a + \varphi_{\alpha})]$ - the matrix element of nucleus with mode $\{\alpha\}$ interaction energy, $V_{n\alpha} = (2\pi \hbar \omega_{\alpha} / V_{0\alpha})^{1/2} (D_{eg} e_{\alpha}) \exp[-i(k_{\alpha} r_n + \varphi_{\alpha})]$ - the matrix element of mode $\{\alpha\}$

with screen (in state $\{n\}$) interaction energy, T_{ae} - the matrix element of nucleus with nucleus electrons system (in state $\{e\}$) interaction energy, $V_{0\alpha}$ - volume of electromagnetic mode $\{\alpha\}$ quantization.

1) For case of free space without screen ($V = 0$) we have the ordinary result

$A(t) = \exp\{i(\Delta\omega_0 + \Delta\omega_e)t - (\Gamma_0 + \Gamma_e)t/2\} \equiv \exp\{i(\Delta\omega_0 + \Delta\omega_e)t - t/2\tau_{tot}\}$, $|A(t)|^2 = \exp(-t/\tau_{tot})$. Here $\tau_{tot} = 1/(\Gamma_0 + \Gamma_e) = \tau/(1 + \alpha)$ - ordinary total life-time of excited nucleus level, $\alpha = \Gamma_e/\Gamma_0$ - internal electron conversion coefficient for excited nucleus, $\tau \equiv 1/\Gamma_0 = 3\hbar c^3/4\omega_a^3|d_{eg}(\omega_a)|^2$ - ordinary radiative life-time of excited nucleus level,

$\Delta\omega_0 + \Delta\omega_e = P \int_0^\infty 2\omega_\alpha^3 |d_{eg}(\omega_\alpha)|^2 d\omega_\alpha / 3\pi\hbar c^3(\omega_\alpha - \omega_a) + P \int_0^\infty |T_{ae}|^2 \rho_e(\omega_a) / \hbar^2 d\omega_\alpha / (\omega_e - \omega_a + \omega')$ - total radiative shift of excited nucleus level, d_{eg} - matrix element of nucleus dipole momentum $\tau_e \equiv \tau/\alpha = 1/\Gamma_e = \hbar^2/2\pi|T_{ae}|^2 \rho_e(\omega_a)$ - internal electron conversion life-time of excited nucleus level.

2) For case of resonant ($\omega_{n0} \approx \omega_a$) screen we have $A(t) = \exp\{i(\Delta\omega_a + \Delta\omega_e)t - t/2\tau_{tot}^*\}$.

Here $\tau_{tot}^* \equiv 1/(\Gamma_a + \Gamma_e) \equiv \tau_{tot}(\Gamma_0 + \Gamma_e)/(\Gamma_a + \Gamma_e) = \tau/\left\{\alpha + \text{Re}\left[(1 - 2i\tau\Delta\omega_0)/(1 + iG/2 - \Delta\Omega_r)^4\right]\right\}$ and $\tau^* \equiv 1/\Gamma_a \equiv \tau(\Gamma_0/\Gamma_a) = \tau/\text{Re}\left[(1 - 2i\tau\Delta\omega_0)/(1 + iG/2 - \Delta\Omega)^4\right]$ - changed total and radiative lifetimes;

$$G = 2N\pi^2 |d_{eg}(\omega_{n0})|^2 / 3\tau_{tot}^* \hbar V_0 \left[(\omega_{n0} - \omega_a)^2 + (1/2\tau_{tot}^*)^2 \right],$$

$$\Delta\Omega_r = 2N\pi |D_{eg}(\omega_{n0})|^2 (\omega_{n0} - \omega_a + \omega') / 3\hbar V_0 \left[(\omega_{n0} - \omega_a + \omega')^2 + (1/2\tau_{tot}^*)^2 \right] \equiv (\omega_{ns} - \omega_a) G \tau_{tot}^* / \pi$$

D_{eg} - matrix element of screen atom dipole momentum.

3) For case of nonresonant ($\omega_{ns} \neq \omega_a$) screen we have $A(t) = \exp\{i(\Delta\omega_a + \Delta\omega_e)t - t/2\tau_{tot}^*\}$.

Here $\tau_{tot}^* \equiv 1/(\Gamma_a + \Gamma_e) = \tau/\left[\alpha + (1 - \Delta\Omega_{nr})^{-4}\right]$ and $\tau^* = \tau/(1 - \Delta\Omega_{nr})^{-4}$ - changed total and radiative lifetimes;

$$\Delta\Omega_r = 2N\pi \sum_s |D_{eg}(\omega_{ns})|^2 (\omega_{ns} - \omega_a) / 3\hbar V_0 \left[(\omega_{ns} - \omega_a)^2 + (2\tau_{tot}^*)^{-2} \right]$$

4) For case of synchronized electromagnetic modes ($\varphi_\alpha = \varphi_\beta = \dots$) we have

$$A(t) = \exp\{i(\Delta\omega_a + \Delta\omega_e)t - t/2\tau_{tot}^*\}.$$

Here $\tau_{tot}^* = \tau/\left\{\alpha + \text{Re}\left[(1 - 2i\tau\Delta\omega_0)/(1 + iG^{(coh)}/2 - \Delta\Omega^{(coh)})^4\right]\right\}$ and

$\tau^* = \tau/\text{Re}\left[(1 - 2i\tau\Delta\omega_0)/(1 + iG^{(coh)}/2 - \Delta\Omega^{(coh)})^4\right]$ - changed total and radiative life-times;

$$\Delta\Omega^{(coh)} = 4\rho_0\pi \sum_s |D_{eg}(\omega_{ns})|^2 (\omega_{ns} - \omega_a + \omega') / 3\pi\hbar \left[(\omega_{ns} - \omega_a)^2 + (1/2\tau_{tot}^*)^2 \right]$$

$$G_r^{(coh)} = 4\rho_0\pi^2 |D_{ge}(\omega_{n0})|^2 / 3\tau_{tot}^* \hbar \left[(\omega_{n0} - \omega_a)^2 + (1/2\tau_{tot}^*)^2 \right],$$

$G_{nr}^{(coh)} \approx 0$, ρ_0 - the density of resonant atoms in the screen.

For case 4) the influence of the screen is by several orders (about $2\rho_0 V_0/N \approx 10^3 \div 10^4$) more effective than for the cases 1), 2), 3) of non-synchronized modes. For this case the increase of radiative life-time may be equals many orders.

The paper also discusses the possible methods of realization and application (for gamma-laser problem) of the phenomenon of controlling the nuclear decay.

THE EXPERIMENTAL REALIZATION AND INVESTIGATION OF THE EFFECT OF CONTROLLING AND CHANGING THE LIFETIME OF GAMMA-EXCITED NUCLEI

V. I. Vysotskii *, V. P. Bugrov, A. A. Kornilova, S. I. Reiman

* Kiev Shevchenko University, Radiophysical dept., 252033, Kiev, Ukraine
Moscow State University, 119899, Moscow, Russia

Abstract. The phenomenon of controlling and changing the lifetime of gamma-radioactive and excited nuclei by action of a resonant screen was investigated. In experiments with the gamma source Sn^{119m} and with the gamma absorber Sn¹¹⁹ we have observed and studied the influence of the position of the resonant absorber upon the width of gamma-spectrum for gamma-quanta passing through this absorber and upon the change of Mössbauer gamma-transition lifetime.

The problem of controlling and changing the total τ_{tot} and radiative τ lifetimes of excited and radioactive nuclei levels is one of the most interesting for future nuclear technology. For free space $\tau_{tot} = \tau / (\alpha + 1)$; $\tau = 3\hbar c^3 / 4\omega_a^3 |d_{eg}(\omega_a)|^2$, α - internal electron conversion coefficient, d_{eg} - matrix element of nucleus dipole momentum.

We have created the theory of resonant screen influence on the gamma-decay probability and lifetime of excited and radioactive nuclei. The phenomenon of nuclear decay controlling is a result of interaction of the nucleus with zero-energy electromagnetic modes, which in turn interact with the screen.

It was shown that the result of action of resonant ($\omega_{no} \approx \omega_a$) screen on the excited nucleus is the change of total and radiative lifetimes

$$\tau_{tot} \rightarrow \tau_{tot}^* \equiv \tau_{tot} (\alpha + 1) / \{ \alpha + \text{Re}[(1 - 2i\tau\Delta\omega_0) / (1 + iG/2 - \Delta\Omega_r)^4] \} = \tau / \{ \alpha + \text{Re}[(1 - 2i\tau\Delta\omega_0) / (1 + iG/2 - \Delta\Omega_r)^4] \},$$

$$\tau \rightarrow \tau^* \equiv \tau / \text{Re}[(1 - 2i\tau\Delta\omega_0) / (1 + iG/2 - \Delta\Omega_r)^4].$$

$$\text{Here } G \approx 2fN\pi^2 |d_{eg}(\omega_a)|^2 / 3 \tau_{tot}^* \hbar V_0 [(\omega_{no} - \omega_a)^2 + (1/2 \tau_{tot}^*)^2],$$

$$\Delta\Omega_r \approx 2fN\pi^2 |D_{eg}(\omega_a)|^2 (\omega_{no} - \omega_a) / 3\hbar V_0 [(\omega_{no} - \omega_a)^2 + (1/2 \tau_{tot}^*)^2] \equiv (\omega_{no} - \omega_a) G \tau_{tot}^* / \pi$$

D_{eg} - matrix element of the screen atom dipole momentum, V_0 - volume of electromagnetic mode quantization, f - Mössbauer parameter,

$$\Delta\omega_0 = \int_0^\infty 2 \omega_\alpha^3 |d_{eg}|^2 d\omega_\alpha / 3\pi\hbar c^3 (\omega_\alpha - \omega_a) - \text{radiative shift of excited level energy of the nucleus,}$$

$$G = 2N\pi^2 |d_{ege}(\omega_{no})|^2 / 3 \tau_{atot} \hbar V_0 [(\omega_{no} - \omega_a)^2 + (1/2 \tau_{tot}^*)^2]; \quad \Delta\Omega_r = (\omega_{ns} - \omega_a) G \tau_{atot} / \pi,$$

For $|G|, |\Delta\Omega_r| \ll 1$ we have

$$\tau_{tot}^* = \tau / [\alpha + 1 - 8f\tau\Delta\omega_0 N \pi^2 c^3 / (\alpha + 1) V_0 \omega_{no}^3] = \tau / [\alpha + 1 - (1 - \tau / \tau^*) f \Delta\Theta / 4\pi],$$

$$\tau^* = \tau / [1 - f\tau\Delta\omega_0 N \pi^2 c^3 / (\alpha + 1) V_0 \omega_{no}^3].$$

For the case of nonresonant ($\omega_{ns} \neq \omega_a$) screen: $\tau_{tot}^* = \tau / [\alpha + (1 - \Delta\omega_{nr})^{-4}]$,

$$\Delta\omega_{nr} = 2\pi \sum_s N_s |D_{eg}(\omega_a)|^2 (\omega_{ns} - \omega_a) / 3\hbar V_{0s} [(\omega_{ns} - \omega_a)^2 + (2 \tau_{tot}^*)^2]$$

The experiments on controlling of the nuclei decay and changing τ_{tot}^*, τ^* were performed according to our theory. The aim of the experiments was to measure the changing (decreasing at $\omega_{no} = \omega_a$) of the spectral width of Mössbauer radiation $\Gamma \equiv 1 / \tau_{tot} \rightarrow \Gamma^* \equiv 1 / \tau_{tot}^*$, (as a result of changing lifetimes τ_{tot}^* and τ^*) during the action of the resonant screen.

In order to reduce the influence of the technical fluctuations, the isotope Sn^{119m} with short lifetime $\tau_{tot} = 1.85 \cdot 10^{-8}$ s, $\alpha = 5.5$ and $\tau = 1.2 \cdot 10^{-7}$ s was used. The layout of the experiment is presented on Fig. 1.

The excited $\text{Sn}^{119\text{m}}$ isotope (chemical compound $\text{CaSn}^{119\text{m}}\text{O}_3$) with activity of 5 mCi was used as a source of Mössbauer radiation 1 with the energy of quanta $E_\gamma = 23.8$ keV. This source has a spectrum of radiation in the form of natural width Γ . The resonant absorber 2 had a form of disk with diameter $D \approx 3$ cm, made of stable Sn^{119} isotope (chemical compound $\text{Sn}^{119}\text{O}_2$ or $\text{CaSn}^{119}\text{O}_3$) and has density $\sigma_m \approx 1.4$ mg / cm² $\approx 6.10^{18}$ nuclei Sn^{119} / cm². This absorber has a spectrum of absorption in the form of natural width Γ .

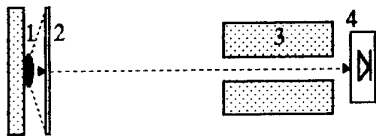

Fig. 1a

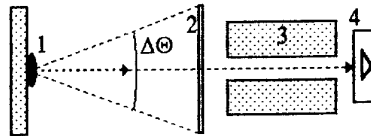

Fig. 1b

The lead diaphragm 3 (diameter $D_1 = 4.5$ cm) had a hole with diameter $D_0 = 1$ cm and length $L_0 = 2.5$ cm. Behind the diaphragm there was a resonant detector 4 and a system for changing the Doppler velocity of detector 4. The measurements with gamma-beam (traveling from source through resonant absorber and diaphragm to resonant detector) were performed in two regimes. In the first regime (Fig. 1a) the resonant absorber 2 was fixed in position near source 1 ($l_1 \approx 0.2$ cm). In the second regime (Fig. 1b) the resonant absorber 2 was fixed at $l_2 = 3$ cm from source in position near diaphragm 3. For the first regime: $N/V_0 \approx 3\sigma_m l_1^2 / l_2^3 \approx 2 \cdot 10^{16}$ cm⁻³. For the second regime: $N/V_0 \approx 3\sigma_m / l_2 \approx 6 \cdot 10^{18}$ cm⁻³.

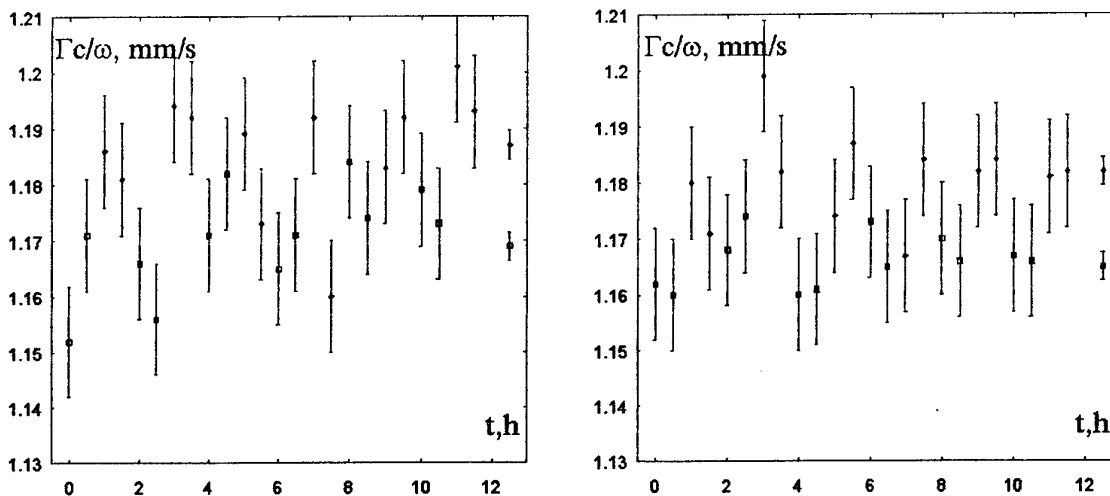

Fig.2

Each measurement of Γ (or Γ^*) in both cases lasted $\Delta t = 0.5$ hour. The results of the measurements are presented in Fig.2 for two series of independent measurements: squares - absorber is situated near source; circles - absorber is situated near diaphragm. The points to the right are the result of averaging the data for all measurements.

The average values measured were $\Gamma = (1.184 \pm 0.003)$ mm/s, $\Gamma^* = (1.167 \pm 0.003)$ mm/s, with corresponding changes (increases) of total lifetime of $\text{Sn}^{119\text{m}}$ $(\tau_{\text{tot}}^* - \tau_{\text{tot}}) / \tau_{\text{tot}} = (0.63 \pm 0.12) \cdot 10^{-2}$ and lifetime for Mössbauer radiative component of $\text{Sn}^{119\text{m}}$ $\tau^* = (1.20 \pm 0.04)\tau$.

For another thin absorber (compound $\text{CaSn}^{119}\text{O}_3$, $\sigma_m \approx 0.7$ mg / cm²) the average values measured were $\Gamma = (1.002 \pm 0.003)$ mm/s, $\Gamma^* = (0.995 \pm 0.003)$ mm/s, $(\tau_{\text{tot}}^* - \tau_{\text{tot}}) / \tau_{\text{tot}} \approx (0.26 \pm 0.12) \cdot 10^{-2}$, $\tau^* \approx (1.08 \pm 0.04)\tau$.

The paper also discusses the possible methods of optimizing the nuclear decay by controlling the phenomena in the gamma-laser problem.

**THE INVESTIGATION OF THE MECHANISM FOR EXCITATION OF
METASTABLE STATES OF NUCLEI DURING INELASTIC SCATTERING
REACTION OF γ -QUANTA ON THE NUCLEUS**

I. V. Sokolyuk , T. M. Zajac

Uzhgorod State University, Department of Nuclear Physics,
294000, Voloshin str. 32/142, Uzhgorod, UKRAINE

Abstract. The shell configurations of transitions from the ^{107}Ag , ^{109}Ag , ^{111}Cd , $^{113,115}\text{In}$ and ^{199}Hg nuclei ground state to the activation levels, corresponding to one-nucleon transitions between the sub-shells within the upper unfilled $2p1f1g$ - and $1h2f3p1i$ -shell, are determined. Using a bremsstrahlung beam of microtron, the integral excitation cross-section of isomeric states of ^{89}Y in (γ,γ') reaction in the energy region 7 - 9.5 MeV has been measured. The activation level near the ~ 8.5 MeV energy in $^{89}\text{Y}(\gamma,\gamma')^{89m}\text{Y}$ reaction was detected. The analysis of these results in the approaches between the proton subshells: not full $2s1f1g$ -shell and empty $2d3s1g1h$ -shell was realized.

The present paper is aimed at drawing attention to the possibility of describing an atomic nucleus by one-nucleon transitions, using the information from one-nucleon transfer reactions. The analysis of the data obtained on the excitation of metastable states of nuclei during (γ,γ') reaction and the information received from one-nucleon transfer reaction allows one to get the information about the excitation mechanism of activation levels [1].

Not disregarding the fact that the nature of metastable states in ^{77}Se , $^{107,109}\text{Ag}$, ^{87}Sr , $^{113,115}\text{In}$ nuclei is different, the excitation mechanism of activation levels through which the population of the metastable states of these nuclei takes place is similar. It means that the excitation of activation levels occurs mainly as a result of one-nucleon transition between sub-shells of the upper unfilled shell $1f2p1g$.

Experimental measurements of the excitation cross-section of the metastable state for the ^{89}Y nucleus shows that within the region of 8.5 MeV, one or a group of activation levels is observed. Such behavior can be described in the approximation of one-proton transitions from the $1f2p1g$ shell to the $2d3s1g1h$ one.

The ^{199}Hg nucleus is very interesting in this regard since there are no experimental data about the levels through which the population of metastable levels may occur. However, the activation levels are revealed by experiment and correlate with those to be observed in neutronic pick-up reaction. This may denote that the transitions from these activation levels to the isomeric level is effected by means of conversion electrons (internal conversion). The experimental finding of such conversion transition would give new information about the mechanism of metastable states population from activation levels.

I. V. S. Dzijamko, I. V. Sokolyuk, T. M. Zajac, Technical Digest of Abstracts of the First Int. Gamma-Ray Laser Workshop, GARALAS'95, August 19-23, 1995, Predeal, Romania, p.27

INFLUENCE OF NUCLEUS SHELL STRUCTURE fpg-SHELL FOR EXCITATION METASTABLE STATES IN (γ, n) REACTION

I. V. Sokolyuk, T. M. Zajac

Uzhgorod State University, Department of Nuclear Physics,
294000, Voloshina str. 32/142, Uzhgorod, UKRAINE

Abstract. An analysis of the isomeric yield (integral cross-section) excitation ratios of isomeric pairs in the odd-odd and even-odd nuclei of fpg-shell in the model of semidirect photoeffect was made. Attention is paid to the weak role of the proton subshell in populating the fpg-shell isomeric pairs.

In the works [1-4] research on the excitation of isomeric states in the even-odd nucleus fpg-shell was made. The structure in the (γ, n) reaction cross-section of the ^{88}Sr , ^{90}Zr , ^{92}Mo nuclei in the near-threshold region, which is correlated to spectroscopic factors of lower levels from pick-up reaction of these nuclei, was found. The correlation between the value of the isomeric integral cross-section ratios for even-odd nuclei of fpg-shell and the ratio of the number N_{1g} of neutrons in the $1g_{9/2}$ subshell and the number N_S of neutrons in the full fpg-shell have been determined (fig.2 [1]). This can be explained by considerable inclusion of semi-direct processes. In this case we can show that the isomeric ratio of the integral cross-sections may be evaluated by means of equation:

$$\eta = \frac{\sum_i S_j(i) a_{i \rightarrow m}}{\sum_j \sum_i S_j(i)}, \quad (1)$$

where $S_j(i)$ - spectroscopic factor of the i -level of j -shell, $a_{i \rightarrow m}$ - the feasibility of metastable state population m from i -level of j -shell. Odd-odd nuclei ^{80}Br and ^{88}Y data agree with the systematics for even-odd nuclei excepting the ^{84}Rb - nucleus. For this nucleus, agreement may be reached by means of equations (1) using experimental data for $S_j(i)$ and $a_{i \rightarrow m}$ [5, 6].

The fact that the behavior of isomeric ratios is similar for even-odd and odd-odd nuclei can represent an argument for the weak role of proton configurations during isomeric state population.

1. V. M. Mazur, Z. M. Bigan, I. V. Sokolyuk, *Int. J. Laser. Phys.* **5**, 273 (1995)
2. V. M. Mazur, I. V. Sokolyuk, Z. M. Bigan *Yad. Fiz.*, **54**, 895 (1991)
3. Z. M. Bigan, V. M. Mazur, I. V. Sokolyuk, *Ukr. Fiz. J.* **35**, 509 (1990)
4. V. M. Mazur, B. S. Bochinyuk, Z. M. Bigan, I. V. Sokolyuk, *Ukr. Fiz. J.* **37**, 1132 (1992)
5. O. S. Shastry *et al.*, *Nucl. Phys.* **A331**, 502 (1979)
6. C. M. Lederer, V. S. Shirley, *Table of isotopes* (New-York, 1978)

THE ISOMERIC STATE OF $^{178}\text{Hf}(16+)$ THEORETICAL STUDYING

T. M. Zajac, I. V. Sokolyuk

Uzhgorod State University, Department of Nuclear Physics,
294000, Voloshina st. 32., Uzhgorod, UKRAINE

Abstract. Systematic calculations of transition probabilities in ^{178}Hf nucleus (isomeric state 16+) from other levels are proposed to be carried out in order to evaluate excitation and deexcitation rates. A generalized model with Nilsson-type potential is considered for the nucleus model. The deformation parameter has been calculated by a modified Hartree-Fock method. A possible decay scheme of long-lived isomers is proposed and calculated.

The problem of gamma-laser creation has a number of aspects without which it is impossible to obtain generation. Thus, to obtain a realistic vision of a certain transition, pretending to create the population inversion and to obtain generation it is necessary to know the transition probabilities to this level from other states, through which, as a rule, the concrete isomeric state is populated. To solve such a problem, information on the studied isomeric state excitation mechanism is rather important. This mechanism can be both collective and one-particle. An essential role may be played by the cascade processes of highly excited activation states decay. There are also several reasons, resulting in a considerable band broadening, which does not favor the achieving of laser generation. This means that a realistic description of excitation and deexcitation processes through which the studied isomeric state is populated and the account of both direct excitation processes and other types of nucleus excitation should be required.

We have calculated the characteristics of ^{178}Hf nucleus ground state on the basis of the Hartree-Fock method with Skirm forces and also have improved the algorithm of HF equations system solution by an iteration method with HF Hamiltonian diagonalization on the basis of the axially deformed harmonic oscillator wave functions, and give the description of the corresponding software.

HF equation for one-particle wave function $F_i(\mathbf{r}, \sigma, q)$ where \mathbf{r} and σ, q denote spatial, spin and isospin coordinates of a nucleon, can be given by [1]:

$$[-\nabla^2 (\hbar^2 / 2m(\mathbf{r}))\nabla + U(\mathbf{r}) + \nabla W(\mathbf{r}) \cdot (-i)(\nabla \times \sigma)] F_i = E_i F_i \quad (1)$$

In this equation, the effective mass $m(\mathbf{r})$ and the central potentials $U(\mathbf{r})$ and $W(\mathbf{r})$ are algebraic functions of Skirm's interaction parameters and nuclear densities ρ , kinetic energy density τ , spin density \mathbf{j} , as well as $\nabla^2 \rho$ and $\text{div } \mathbf{j}$, being expressed $F_i(\mathbf{r}, \sigma, q)$.

The probability was calculated as [2]:

$$B(\lambda, I \rightarrow I') = \left| \langle I\lambda K K' - K | I\lambda I' K' \rangle \int F_{\Omega}^{'+} M(\lambda, K' - K) F_{\Omega} d\tau + \langle I\lambda K - K' - K | I\lambda I' - K' \rangle \int [(-)^{I-j} F_{-\Omega}']^+ M(\lambda, -K' - K) F_{\Omega} d\tau \right|^2 \quad (2)$$

1. D. Vautherin, D. M. Brink, Phys. Rev. C7, 293 (1973)
2. S. G. Nilsson, Kgl. Danske Vidensk. Selsk., Mat.-Fys. Medd. 29, 1 (1955)

GAMMA-OPTICS FIBRE CREATED BY COHERENT LIGHT

R. N. Shakhmuratov

Kazan Physical-Technical Institute of Russian Academy of Sciences
10/7 Sibirsky trakt st., Kazan 420029 Russia

Abstract. We propose a new scheme of gamma-quanta amplification without inversion. Laser pumping of electron states creates giant nuclear-spin polarization via hyperfine interaction. This results in extremely deep cooling of ground-state nuclear spin in a projection which does not absorb laser pump and gamma-quanta as well according to the selection rules of these transitions. Induced emission from nuclear excited state is not influenced by pumping. Therefore, gamma-quanta traveling inside the pump beam have a chance to induce stimulated emission without subsequent quenching by ground state nuclei. This process is similar to photon transmission in optic fibers and we nominate the pump beam as gamma-optic fiber.

Lasing becomes increasingly difficult as the wavelength of radiation becomes shorter and reaches the gamma-ray band. A first difficulty comes from the small nuclear cross sections relative to atomic ones. The second, most serious obstacle arises from the enormous energy flux necessary to create population inversion of nuclear states. Many concepts were proposed to reduce pump requirements. One of them is a gain without inversion (GWI) of population of absorbing and emitting nuclear states [1, 2]. In this report we consider recoilless gamma-ray transitions as the resonance cross section of Mössbauer nuclei is high. This choice diminishes the first obstacle.

It is well recognized that resonant gamma-absorption and gamma-emission of Mössbauer nuclei are reciprocal, since the corresponding cross sections are equal to each other. Consequently, gamma-lasing in a Mössbauer sample can be achieved only when the number of excited nuclei predominates over ground-state nuclei number. We present a method which breaks this reciprocity and show the way to achieve gamma-lasing without population inversion. Thus, the second obstacle becomes a solvable problem as well.

Our method has its origin in the new principle of lasing without inversion formulated for the optical band [3-5]. We develop a new scheme of induced gamma-emission amplification which differs from that proposed in [1]. That approach contains radio-frequency (RF) excitation of nuclear spin states when spin levels crossing in external magnetic field takes place. This RF-scheme demands deep cooling of the sample down to milli-kelvin temperatures. Since at room temperature the RF-scheme does not provide GWI, one can consider it as a supplement for lasing with population inversion created by deep cooling. In our scheme we propose to excite spin-sublevels of ground-state nuclei by resonant laser pump via hyperfine interaction. We apply magnetic field parallel to the c axis of a noncubic uniaxial crystal, as in paper [1], to obtain nuclear spin sublevels crossing. A small misalignment of the magnetic field with the c -axis gives strong mixing of $-1/2$ and $-3/2$ spin states in their crossing point. Mixed states split into doublet g . The energy diagram with state functions is shown in Fig.1. The excited electron state creates different hyperfine field on nuclear spin, so when the electron is excited by laser pumping, the nuclear spin sublevels do not cross each other. We show only the nuclear spin state $-1/2$ in excited state h , as the pumping transition has a selection rule $\Delta M = \pm 1$. It is supposed that the nucleus has another spin in its excited state e . The selection rule of the nuclear transition is taken the same as for the pumping transition. The gamma-quanta are modeled by Lorentzian irradiation with randomly shifted phase. Mean dwell time between successive phase shifts is equal to the lifetime of nucleus in excited state e . One gamma-quantum induces Raman excitation of the ground state doublet g when the frequency of phase shift g is faster than the doublet split frequency ω_d . Laser

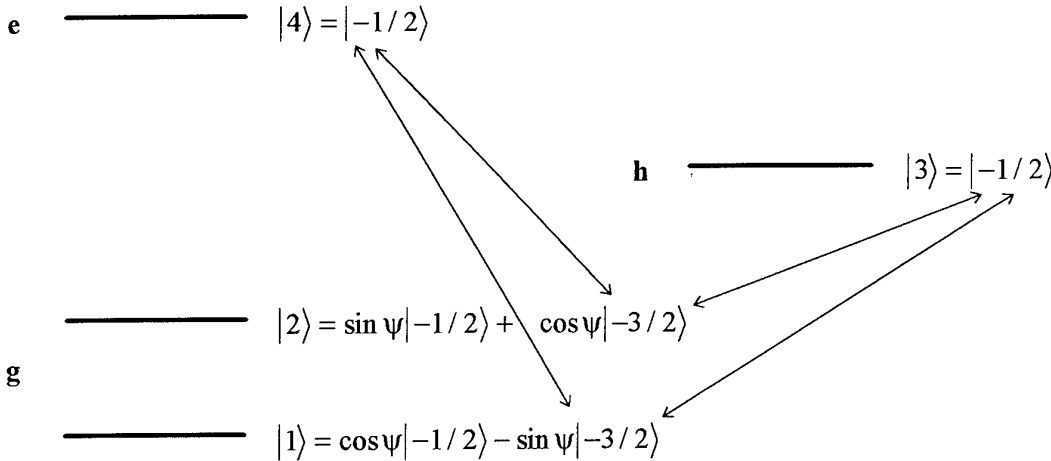

Fig. 1. Energy diagram of gamma-quantum absorption and Raman pump of ground state nuclear spin

pump is described by the phase diffusion model. It induces Raman excitation of the nuclear spin doublet **g** when the decay rate of the electron coherence (i.e. electron polarization) Γ is larger than the doublet split frequency ω_d . We found that in the condition of:

$$\Omega^2 \gg \Gamma \Gamma_M ; \Gamma \omega_d, \quad (1)$$

where Ω is the Rabi frequency of electron excitation, Γ_M is a dephasing rate of the doublet spin coherence, giant transverse spin polarization takes place even at room temperature. Ground state nucleus is polarized in spin projection:

$$|-1/2\rangle = \frac{1}{\sqrt{2}} |1\rangle + \frac{1}{\sqrt{2}} |2\rangle = \frac{1}{\sqrt{2}} (\sin \psi + \cos \psi) |-1/2\rangle + \frac{1}{\sqrt{2}} (\cos \psi - \sin \psi) |-3/2\rangle \quad (2)$$

when $\psi = \pi/4$ and hence gamma-quantum absorption vanishes. This polarization is impossible to create by RF-excitation even at moderate sample cooling. We show that gamma-absorption along the laser beam vanishes when nuclear-spin selection rules for gamma transition and laser pumping are the same and the spin mixing is close to perfect ($\psi = \pi/4$). The emission cross section is not affected as the excited nuclear spin state is not polarized. When the selection rules are opposite, the gamma-absorption cross section becomes larger than the emission cross section and instead of lasing one can get enhanced absorption.

We formulate the principle how to create a wave-guide for gamma quanta. Any gamma-quantum traveling within the laser beam parallel to its direction is not absorbed in ground-state nuclei and this quantum has a chance to induce stimulated emission. Other quanta are absorbed in outside nuclei when they leave the laser beam. This kind of quantum traveling reminds of light transmission in optics fibers. Therefore, we refer to our wave-guide as gamma-optics fiber. Thus, even a small fraction of excited nuclei inside this fiber may cause lasing without inversion, since the rest, ground-state nuclei become transparent for gamma-quanta. We have to stress out that there is no sample heating by the pump beam as this beam is also not absorbed due to giant-spin induced polarization. Nonexhausting pumping is important from the point of view of lasing length as well.

This work is supported in part by ICIGE, Phase I.

1. R. Coussement *et al.*, Phys. Rev. Lett. **71** (1993) 1824
2. O. A. Kocharovskaya, Laser Physics **5** (1995) 284
3. O. A. Kocharovskaya, Ya. I. Khanin, Sov. Phys. JETP Lett. **48** (1988) 630
4. M. O. Scully, S.-Y. Zhu, A. Gavrielides, Phys. Rev. Lett. **62** (1989) 2813
5. S. E. Harris, Phys. Rev. Lett. **62** (1989) 1033

**SEMICLASSICAL INTERACTION
BETWEEN MONOCHROMATIC ELECTROMAGNETIC RADIATION
AND AN ATOM WITH TWO UNSTABLE LEVELS**

Yu. A. Romashev, G. A. Skorobogatov

Dept. of Chemistry, St. Petersburg State University,

Petrodvorets, 198904 St. Petersburg, RUSSIA

Interaction between electromagnetic radiation and a two-level atom is considered in the framework of the quasi-classical approximation. It is shown that the non-stability of the lower level does not increase the cross-section of the stimulated emission more than it follows from the 2nd Einstein equation.

LONG-LIVED POSITRONIUM IN THE FIELD OF AN OPTICAL LASER

O. N. Gadomsky, K. V. Krutitsky^{*}, T. T. Idiatulov

Ulyanovsk State University, 42 L. Tolstoy Str., Ulyanovsk 432700, Russia

^{*} Ulyanovsk Branch of the Institute of Radio Engineering
and Electronics of Russian Academy of Sciences,
48 Goncharov Str., Ulyanovsk 432700, Russia

Abstract. We propose one-dimensional model of Gamma-ray laser on the basis of annihilation superradiation phenomenon [1, 2]. We consider this problem as part of quantum positronics.

In this report a theory of quantum transitions of the positronium atom (Ps) is developed which takes into account two-photon annihilation decay and optical transitions between two arbitrary states of Ps. The problem is considered without making use of the perturbation theory, by solving sixteen Heisenberg equations for photonic and atomic operators [3]. Solutions of these equations are used to calculate radiative shifts of the energy levels of Ps, phase relaxation times and lifetimes, taking into account spontaneous transitions and transitions stimulated by optical laser. Radiative and nonradiative interactions of Ps with the photon field are distinguished. The role of coherent effects in Ps due to feedback with the fields of intrinsic and external photons is discussed. The kinetics of annihilation decay is investigated for various initial conditions. In addition, it is shown that long-lived atoms of parapositronium can be formed in the field of an optical laser if one of the states of Ps is a Rydberg state [4].

1. O. N. Gadomsky, K. V. Krutitsky, *Quantum positronics and cooperative phenomena*, Technical Digest of Abstracts of the First International Gamma-Ray Laser Workshop (GARALAS'95), Predeal, August 19-23, 1995, p.24
2. O. N. Gadomsky, K. V. Krutitsky, *Annihilation Superradiation*, Laser Physics 5 (2), 379-395 (1995)
3. O. N. Gadomsky, *The positronium atom in the field of an optical laser*, Zh. Eksp. Teor. Fiz. 110, 1228-1243 (1996) [JETP 83, 676 (1996)]
4. O. N. Gadomsky, T. T. Idiatulov, *Long-lived positronium in the field of an optical laser*, submitted to Quant. Electr.

GAMMA-RAY SOLID LASER: STEADINESS AGAINST BOTH THE SELF-RADIATION DEFECTS AND THE SELF-HEATING

S. V. Karyagin

Semenov Institute of Chemical Physics, Russian Academy of Sciences

Kosygin str. 4, 117334, Moscow, Russia

Fax: +095-137-8318

A complex of real threshold conditions (CRTC) for the gamma-laser (GL) is considered here taking into account a joint influence of both the self-radiation defects (SRD) and the self-heating in the active medium (AM). A work-line-broadening from the SRD is enhanced by the self-heating due to a feed-back between the SRD, CRTC and the self-heating. Such CRTC is a more strict test for the GL-realization than the CRTC, taking into account only the self-heating. The solid (Mössbauer) active media stands this test in the contrary with the non-Mössbauer media (plasma, gaseous, atomic beams, etc.).

A development of the concept for the Suppression of the Heat Release and InterRelated Effects (SHRIRE) represented in the serial "GAMMA-RAY SOLID LASER" on the 1-st International Workshop Predeal'95 is reported here. The high release of energy (more than 100 eV/atom) during lasing within an Active Medium (AM) is accompanied by intensive heat release, high density of radiation defects and strong interrelated effects [1-9]. The importance of these phenomena for the real threshold conditions of Gamma-Laser (GL) was repeatedly accentuated by many authors [1-9]. Particularly, the works [4-6] were devoted to these phenomena in GL and to the proposition of the complex measures for the Suppression of the Heat Release and InterRelated Effects (SHRIRE). In the present work, a more strict complex of real threshold conditions (CRTC) enhanced by the influence of the radiation defects of high density is considered. The main results of such consideration are:

- The active media of GL must be solid (Mössbauer);
- The use of the complex of measures for the SHRIRE, suggested in [4-8], is enough to satisfy the most strict CRTC considered here.

These results are useful to choose the type of active media for the different gamma-laser models, e.g. two-step activation, two-phase pumping, gamma-ray amplification without inversion, two photon generation, etc.[9].

1. G. C. Baldwin, J. C. Solem and V. I. Gol'danskii, *Rev. Mod. Phys.* **53** (1981) 687
2. G. C. Baldwin and J. C. Solem, *Laser Phys.* **5**(2) (1995) 231
3. B. Balko, I. W. Kay, J. D. Silk, and D. A. Sparrow, *Laser Phys.* **5**(2) (1995) 355
4. S. V. Karyagin, *Zh. Exp. Teor. Fiz.* **79** (1980) 730
5. S. V. Karyagin, dep. pap., *Vs. Inst. Nauch. Tech. Inf. (VINITI)*, no.2797-83 Dep., (1983) 61pp. (in Russian)
6. S. V. Karyagin, *Laser Phys.* **5**(2) (1995) 343
7. S. V. Karyagin, invited lect., in *Proc. Int. Conf. on Mössbauer Spectroscopy*, Bucharest, eds. D. Barb and D. Jarina, vol.2 (1977) 1-33 (in Russian)
8. S. V. Karyagin, series "Gamma-Ray Solid Laser" (1995), in ref. [9]
9. *Proc. 1st Int. Gamma-Ray Workshop, Predeal, GARALAS'95*, in special issue of journal *Hyperfine Interactions*, Amsterdam, 1996

ABOUT OPTICAL MODELING OF MÖSSBAUER GAMMA-RAY LASER GENERATION

S. A. Moiseev

E. K. Zavoiskii Kazan Physical-Technical Institute,
Kazan, Science Center, Russian Academy of Sciences,
10/7 Sibirskii Trakt, Kazan, 420029, Russia

Abstract. An optical model for the study of the coherent dynamics in Mössbauer gamma-ray laser is proposed. The necessity of this optical model and its possible experimental realizations are discussed.

There are theoretical investigations devoted to the study of laser's dynamics in the regime of nuclear superradiance (cooperative Dicke-decay) [1-3]. These theories solve some important questions in one of the Parts of Global Problem (GP-Parts) - gamma laser creation. So far, both the experiments examining these theories are absent and there is no complete solution of GP. On the other hand, the absence of these experiments brakes the progress towards the general solution of the Global Problem.

Obtaining any experimental data about the collective nuclei irradiation laws is an insoluble problem in gamma range [4]. Instead of waiting until the pumping and heating problems of GP [5, 6] are solved, it is desirable to obtain experimental information about the laws of cooperative nuclei gamma irradiation. Obviously, the straight way to the knowledge of these laws in temporal gamma lasing would be to perform the experiments in gamma region, but this is practically impossible. Nevertheless, it is possible to propose experiments which are feasible given the experimental possibilities of our days, by which the laws of the temporal collective gamma irradiation can be experimentally studied in detail. This problem could be solved in the following way. Many of these experiments can be realized if we will grow the media (crystals) with special concentration of atoms and its parameters such as (from the general point of view on the problem) the mathematical equations of the laser optical generation would coincide exactly with the similar equations for nuclear gamma transitions. The possibility of this mathematical similarity can be based on the Mössbauer effect, if only the relations between the wavelengths of the field generation and the atomic concentration will be also included in the optical region.

This experimental model will differ from the ordinary optical laser mainly by the low atomic concentration and can be realized in ordinary ruby-like crystals. Obviously this optical laser will not be the best model for the generation of optical field. It is probable that the lasers are not studied in optics in detail especially from the point of view of gamma-ray laser problems.

Why these modeling experiments can be interesting and what physical tasks of GP can be proposed for solution now? One of the answers exists. The contemporary gamma laser's theories, like [3], are developed using the spatial averaging of nuclei parameters. As a result, the theories are mathematically closed to the theories developed for optical lasers. It is especially important to mark that in the optical region the averaging for the physical parameters of the medium are performed in the small space inside the volume λ^3 . In this small volume ($< \lambda^3$) the coherent properties of the lasing field are formed with more efficiency at the beginning of lasing. In the

same time, in the gamma region, the wavelength is smaller with respect to the interatomic distance. Moreover, this situation is strengthened in the case of not total pumping of active nuclei, that will be as a rule for gamma laser. Thus, the dynamical laws of coherence initiation will differ in the same physical conditions. Nevertheless, now the mathematical structure of the contemporary theories stays as in optics. That is the effects of small wavelength have not yet been understood and sufficiently studied. It is not clear what physical difficulties are connected with existing simplification of the used theory, as it is difficult to examine it.

First of all, at this relation of wavelength with respect to the internuclear distance the ordinary coherent (Dicke superradiance) dynamics will be suppressed even for Mössbauer conditions of gamma laser. The second sensitive consequence will be the growth of the field's fluctuations in the initial stage of the temporal behavior of the generation. Obviously, the role of quantum fluctuations will be more important for gamma lasing, while in optics these questions are more important near the threshold. These difficulties can be the additional reasons for the search of time stable coherence initiation of the cooperative nuclei dynamics.

These questions are possible to model and study in optical experiment, where both single optical photons can be detected and necessary atomic parameters can be realized at the special crystals. Some quantitative estimations of laser crystal [7] which can be the models of the perspective nuclei transitions [5] of gamma lasers are performed.

1. A. V. Andreev, Sov. JETP **48**, 630 (1977)
2. S. V. Karyagin, Sov. JETP **79**, 730 (1980)
3. B. Balko, I. W. Kay, I. D. Silk, and D. A. Sparrow, Laser Physics **5**, 355 (1995)
4. G. A. Skorobogatov and B. E. Dzevitskii, Laser Physics **5**, 258 (1995)
5. C. B. Collins and J. J. Carroll, Laser Physics **5**, 209 (1995)
6. S. V. Karyagin, Laser Physics **5**, 343 (1995)
7. A. A. Kaminskii, B. M. Antipenko, *Multilevel Operating Schemes of Crystalline Lasers* (Nauka, Moscow, 1989), 270 p.

SEARCH OF THE STRUCTURES AND COMPOUNDS, USEFUL FOR THE SELF-STIMULATION DETECTION IN LONG-LIVED NUCLEAR ISOMER DECAY

Yurij I. Zhirko

Institute of Physics, National Academy of Sciences
252028, Prospect Nauki, 46, Kiev-28, Ukraine

**Galina N. Kozeratskaja, Tamara M. Petrenko, Andrej V. Vasin
and Vladimir I. Kirischuk**

Scientific Center "Institute for Nuclear Research", National Academy of Sciences
252028, Prospect Nauki, 47, Kiev-28, Ukraine

Abstract. For the successful search of self-stimulation in long-lived isomers ^{125m}Te and ^{123m}Te , one needs to use the Te compounds with extremely high Debye temperature. ZnTe crystals, having the Debye temperature as high as $\Theta_D(\text{ZnTe}) = 295\text{K}$, appear to be quite useful for the experiments, moreover, not too less effective than BeTe. On the other hand, there are both simple and complex tellurium compounds, the Debye temperature of which could be even much higher than that for BeTe and it is very interesting to try to synthesize them.

It is well-known that to observe the Mössbauer Effect with high-energy γ -transitions ($E_\gamma > 80\text{ keV}$) a host having a high Debye temperature, Θ_D is essential. That is why, for the search of self-stimulation in long-lived isomers ^{125m}Te ($E_\gamma = 109.27\text{ keV}$) and ^{123m}Te ($E_\gamma = 88.5\text{ keV}$), one needs to use the Te compounds with extremely high Debye temperature. One of such structures is the ZnTe crystal, the Debye temperature of which, according to the estimate got in [1], should be around 250-300K. More precise estimate can be obtained taking into consideration that the maximum energy of the phonons in ZnTe (LO phonon) is equal to 205 cm^{-1} [2] and that corresponds to the Debye temperature $\Theta_D(\text{ZnTe}) = 295\text{K}$. Thus, the f-factors, which define the fraction of recoilless photons, for the isomeric transitions in ^{125m}Te and ^{123m}Te at liquid nitrogen temperature ($T = 78\text{K}$) will be equal to 1.2% and 5.3%, respectively, almost as it has been supposed in [1].

Unfortunately, we cannot guarantee the ideal quality of our ZnTe crystals, since they were grown from rather small amounts of highly enriched isotopes. As a good fortune, ^{125m}Te is an well-known Mössbauer nucleus and there is a chance for the recoil-free fraction of the samples to be carefully measured.

At the same time, though Be has really very high Debye temperature ($\Theta_D(\text{Be}) = 1440\text{K}$), BeTe compound is not the most useful for the search of self-stimulation in long-lived nuclear isomers, because of the very small atomic weight of beryllium. Really, for the case of an impurity of mass m_i , in a monatomic Debye solid characterized by m_h , experience has shown that one merely needs to replace the host Θ_D by an effective Debye temperature:

$$\Theta_D^{\text{eff.}} = \Theta_D \sqrt{\frac{m_h}{m_i}}, \quad (1)$$

So, the Debye temperature of, for instance, such a compound as CrTe turns out to be equal to 406K, a bit higher than that for BeTe (for which $\Theta_D(\text{BeTe}) = 390\text{K}$), though the Debye temperature of chromium is much lower ($\Theta_D(\text{Cr}) = 630\text{K}$), than the Debye temperature of beryllium. Moreover, for the compound RuTe, since $\Theta_D(\text{Ru}) = 600\text{K}$, the Debye temperature will be equal to 539K, i.e. even much higher, than in the case of BeTe.

However, the most useful could be compounds of Te for which the monatomic solid with rather high Debye temperature is characterized by much larger mass than the tellurium mass. There is a small group of transitional elements as W, Re, Os and Ir, the Debye temperatures of which are in the range of 400K-500K. Thus, the Debye temperature of WTe appears to be equal to 485K and the Debye temperature of OsTe - as high as 616K. Moreover, since all that are the diatomic compounds, high-frequency optic modes is present in addition to the acoustic modes. The presence of these modes can substantially enhance the f-factor of a solid, so that the effective Debye temperature will be even higher than what one can get according to (1). For example, according to (1) the Debye temperature of BeTe is equal to 390K, whereas it used to be estimated as 440K.

So, the f-factors, which define the fraction of recoilless photons, for the isomeric transitions in ^{125m}Te and ^{123m}Te at the liquid nitrogen temperature ($T = 78\text{K}$) will be equal to 11.6% and 23.8% in the case of WTe and to 20.1% and 34.3% in the case of OsTe, respectively. It is interesting that at the measurement temperature $T \rightarrow 0$ the f-factors reach 15.9% and 29.3% in the case of WTe and even 23.5% and 38.0% in the case of OsTe for ^{125m}Te and ^{123m}Te , respectively. Thus, one can note that there is no need to measure WTe and OsTe samples at liquid helium temperature, the liquid nitrogen temperature would be quite enough.

Some more complex compounds of Te are very interesting as well. For example, it was mentioned [3], that room temperature Mössbauer spectra of the 35.5 keV gamma resonance in ^{125}Te have become possible to observe using a Mg_3TeO_6 matrix. The T-dependence of the f-factor in the Mg_3TeO_6 host has shown that such a matrix has rather high Debye temperature.

1. V. I. Kirischuk, *Search for Stimulated γ -Ray and Conversion Electron Emission*, Laser Physics 5 (2), 268-271 (1995)
2. W. G. Nilsen, *Second-order Raman spectra of some zinc blende and wurtzite crystals*, In: *Light scattering spectra of solids*. Ed. by G. B. Wright (Berlin, Springer-Verlag, 1969), p. 129-137
3. P. Boolchand, *Experimentally realized linewidths of narrow ($\leq 10^{-10}$ eV) nuclear gamma resonances*, J. Quant. Spectrosc. Radiat. Transfer 40 (6), 777 - 795 (1988)

AN ADVANCED TECHNIQUE OF THE SEARCH FOR THE STIMULATED GAMMA-RAY EMISSION

Nikolaj V. Strilchuk and Vladimir I. Kirischuk

Scientific Center "Institute for Nuclear Research", National Academy of Sciences

252028, Prospect Nauki, 47, Kiev-28, Ukraine

Abstract. An experiment, which is not based on the assumption that the stimulating and stimulated photons are time-coincident, is proposed. The idea is to compare, for the source in the form of a long filament, the number of simple pulses, corresponding to the isomeric transition energy, counted in the axial direction with the number seen off-axis. It is interesting that, if the stimulating and stimulated photons are time-coincident, such the technique has essential advantages as well.

As it has already been mentioned before [1], long-lived nuclear isomers ^{125m}Te and ^{123m}Te have the best chances in the experimental search for the stimulated γ -ray emission. Moreover, if, in the case of ^{125m}Te , the measurements of single γ -ray spectra have the highest accuracy in observing the peaks corresponding to twice the isomeric transition energy, then, in the case of ^{123m}Te , it is more preferable to register the coincidence spectrum.

And though we believe that the γ -ray stimulation process is really instantaneous [2] and, as a result, the stimulating and stimulated photons should be time-coincident and can be registered simultaneously by a detector as the sum peak, we are planning to perform another experiment, which is not based on the assumption that the stimulating and stimulated photons are time-coincident. The idea is for the source in the form of a long filament to compare the number of simple-energy pulses, corresponding to once the isomeric transition energy, counted in the axial direction with the number seen off-axis. In order to eliminate the factor of time it seems to be useful to collect the γ -spectra for the rather short and equal intervals of time by the same detector as along the axis as off-axis alternately, simply turning the source around. For that purpose a rotating system has been developed and designed (Fig. 1), which turns the source over 90 degrees to the right just as the exposure is over. As a result, we can collect simultaneously in different buffers as many as four γ -ray spectra, two in the axial direction and two in the off-axis one. One can expect that the stimulated photons would be detected preferably in the on-axis spectra, and, on the other hand, they are practically absent in the off-axis spectra.

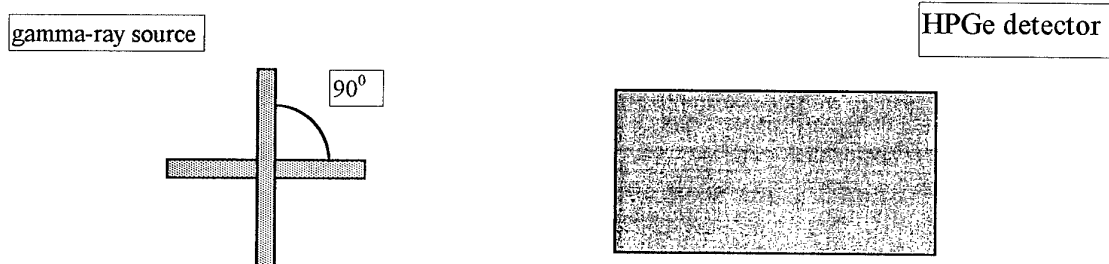

Fig. 1. Schematic representation of the experimental set-up, which rotates the gamma-ray source 90° to the right every time, when the exposure is over.

It is interesting that, if the stimulating and stimulated photons are time-coincident yet, such a technique has some and quite essential advantages, as well. For instance, as for a pile-up problem, it is well-known that because the summing effects will depend on the square of the detector solid angle, whereas the simple peaks vary linearly, the relative effect of summing can be reduced by reducing the solid angle. So, having found the peaks corresponding to twice the transition energy, we can easily test whether they are the result of the stimulated γ -ray emission or not, by simply changing the source-detector spacing. Another way to check it is the change of the source temperature. Naturally, for example, at room temperature the probability of the stimulated γ -ray emission is so small that all impulses registered in the peaks corresponding to twice the isomeric transition energy will be exclusively chance coincidences because of the summing effect.

At the same time, by measuring the γ -spectra according to the technique described above, the pile-up problem can be solved quite naturally. Really, in the on-axis spectra, the impulses detected in the peak corresponding to twice the isomeric transition energy, will be the result of both the stimulated γ -ray emission and the chance coincidences, whereas in the off-axis spectra practically every impulse, detected in the peak, is the accidental sum peak. Moreover, because the number of the chance coincidences in both kinds of spectra would be practically the same, it seems to be very useful that there is a possibility to extract apart and quite naturally the effect of the stimulated γ -ray emission.

1. V. I. Kirischuk, *Search for Stimulated γ -Ray and Conversion Electron Emission*, Laser Physics 5 (2), 268 (1995)
2. V. I. Kirischuk, *On the Time-Dependent Character of Resonant γ -Ray Absorption and Stimulation*, First International Gamma-Ray Laser Workshop, GARALAS '95, Romania, Technical Digest of Abstracts, 34

**EXPERIMENTAL TECHNIQUE FOR DETECTION OF INDUCED GAMMA
EMISSION IN TRANSITION $\text{Te}(125\text{m}, 2) \rightarrow \text{Te}(125\text{m}, 1) + \gamma(109.27 \text{ keV})$**

B. E. Dzevitskii, V. N. Gitsovitch, V. G. Semenov, G. A. Skorobogatov

Dept. of Chemistry, St. Petersburg State University,

Petrodvorets, 198904 St. Petersburg, RUSSIA

e-mail: gera@mail.moss.pu.ru

We present a series of experimental details for the observation of an induced gamma emission in the M4 transition [1, 2]

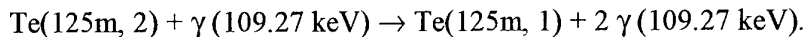

In the first place, we studied the dependence of the value of the effect under measurement on the lower level stability (or non-stability).

Secondly, we offer the optimal mode for the tellurium-125m(2) preparation in concentration just higher than 10^{21} atoms per cm^3 .

Thirdly, we studied the dependence of the measured effect value on the type of solid matrix containing the tellurium-125m(2).

Fourthly, we offer to combine the special filters which permit to separate the gamma radiation 109.27 keV and double-energy quanta 218.54 keV under investigation from bremsstrahlung and other background radiation.

In the fifth place, we propose to use the appropriate types of preamplifier, detector, and other electronic units of the experimental setup.

1. G. A. Skorobogatov, B. E. Dzevitskii, *Izvestija Acad. Sci. USSR, Ser. Phys.*, **48** (10), 1934-1939 (1984) (in Russian)
2. G. A. Skorobogatov, B. E. Dzevitskii, *Laser Physics* **5** (2), 258-267 (1995)

CROSS SECTION FOR THE STIMULATED EMISSION OF 109.28 keV GAMMA RAYS FROM ^{125m}Te

R. S. Rundberg, M. M. Fowler, R. D. Taylor, and J. B. Wilhelmy

Los Alamos National Laboratory, Los Alamos, NM 87545 USA

The stimulated emission of gamma rays from a nuclear isomer are expected to result in collinear photons and therefore observable as a sum peak in gamma spectrum. Skorobogatov and Dzevitiskii [1] reported a greatly enhanced sum peak (218.56 keV) when a sample of beryllium telluride containing ^{125m}Te was cooled from room temperature to near liquid helium temperatures. We have repeated their experiment and have observed no increase in the sum peak above accidental summing. The upper limit for the stimulated emission cross section based on the three standard deviation statistical error is $1.1 \times 10^{-20} \text{ cm}^2$.

A polycrystalline rod of beryllium telluride containing enriched isotope ^{124}Te was prepared according to the method described by Skorobogatov and Dzevitiskii [1]. The Be^{124}Te sample was irradiated in the High Flux Beam Reactor, HFBR, producing 0.19 Curies of ^{125m}Te . The intensity of the sum peak was measured as a function of angle, source-detector distance, and temperature using a coaxial intrinsic germanium detector. The data were represented as the ratio of the sum peak rate to the square of the singles in order to eliminate sensitivity to the reproducibility and precision of the source-detector position as well as the decay of the ^{125m}Te . This ratio is equal to the resolving time of the gamma ray spectrometer. Deviation from accidental summing at liquid helium temperature particularly at angles in line with the axis of the BeTe rod would be evidence of stimulated emission. No significant difference was observed in the sum peak ratio. The pulse pair resolving time was found to be 800 nanoseconds for a Tennelec TC-245 spectroscopy amplifier with using a pulse shaping time of 8 microseconds without pileup rejection. The pulse pair resolving time could be reduced to 350 nanoseconds by using the linear pileup rejecter. The pulse pair resolving time could be further reduced to 100 nanoseconds by reducing the shaping time of the amplifier to 0.75 microseconds. This resulted in a degradation of the energy resolution of the detector from 1 keV to 1.5 keV. The sum peak ratios observed were all consistent with accidental summing.

The beryllium telluride sample was reworked because the lack of any observable effect could be due to the formation of a low Debye temperature solid. The sample was reacted at 1100 degrees Celsius with excess beryllium thought to ensure a high Debye temperature solid. The Debye temperature of the resulting solid was determined to be 390 ± 20 degrees Kelvin by Mössbauer spectroscopy on the 35.5 keV transition. The gamma spectrum of this new solid was also measured at a distance of 21 centimeters from the germanium detector. No significant difference was observed between the sum peak at room temperature and liquid helium temperature for the reworked sample. The spectra in the vicinity of the sum peak are shown in Fig. 1. The peaks below the sum peak were identified as activation products from the naturally occurring isotopes of tellurium. The upper limit for the stimulated emission cross section based on the three standard deviation statistical error is $1.1 \times 10^{-20} \text{ cm}^2$. This result is nearly one order of magnitude lower than the cross section reported by Skorobogatov and Dzevitiskii[1]. Our results support the position of Baldwin and Solem [2] over that of Kamenov[3].

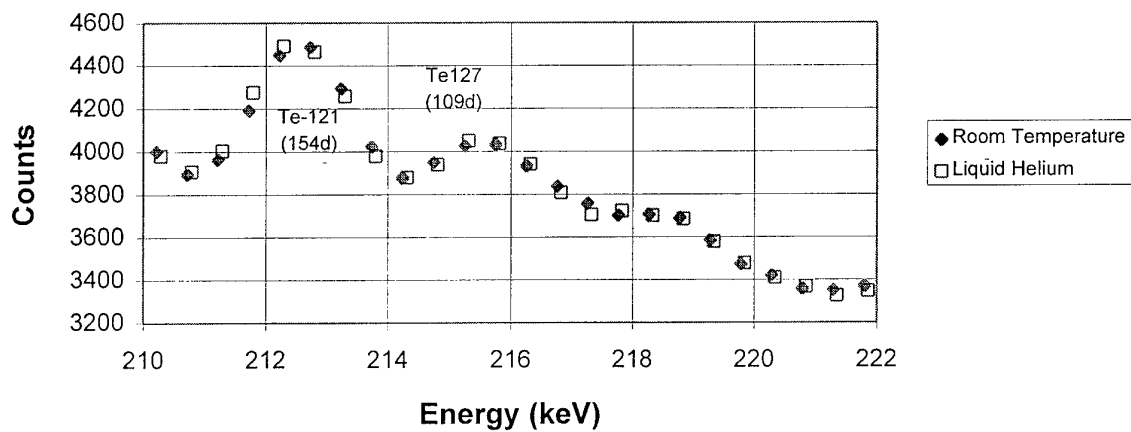

Figure 1 Gamma ray spectra in the region of the sum peak (218.56 keV) taken at room temperature and liquid helium temperature.

REFERENCES

1. G. A. Skorobogatov and B. E. Dzevitskii, *Laser Physics* **5**(2), 258-267 (1995)
2. G. C. Baldwin and J. C. Solem, *Il Nuovo Cimento D* **16**, 627-630 (1994)
3. P. S. Kamenov, *Il Nuovo Cimento D* **13**, 1369-1377 (1991)

AUTHOR INDEX

ADAM, J.	21	GADOMSKY, O.N.	95
AGANIN, A.A.	65	GANCIU, M.	29, 31
AGEE, F.J.	7	GANGRSKY, YU.P.	25
ALEXEEV, S.A.	53	GITSOVICH, V.N.	57, 105
ALPATOV, V.G.	41, 43, 45	GORDIENKO, V.M.	15
ANDREEV, A.V.	15	GUDENKO, S.V.	61
ANDRIANOV, S.N.	47, 49	HENING, A.	33
ARISAWA, T.	27	HO, Y.K.	77
BAYUKOV, YU.D.	41	HOFFMANN, D.H.H.	31
BELOV, A.G.	25	IDIATULOV, T.T.	95
BORZAKOV, S.B.	43	ISAEV, YU.N.	41, 43, 45
BRIANÇON, CH.	19	ISRAILEV, I.M.	23
BUGROV, V.P.	83	KAPELNITSKII, S.V.	61
CARROLL, J.J.	1, 21	KARAMIAN, S.A.	21
CHEREPANOV, V.M.	61	KARYAGIN, S.V.	97
CHINAeva, V.P.	43	KARTASHOV, G.R.	41, 43, 45
CHUEV, M.A.	61	KIRISCHUK, V.I.	101, 103
COLLINS, C.B.	1, 3, 21, 29	KOCHAROVSKAYA, O.	79
COUSSEMENT, R.	37, 39	KÓLESOV, R.	79
DAVYDOV, A.V.	41, 43, 45	KORNILOVA, A.A.	83
DEWALD, E.	31	KOROTKOV, M.M.	41, 43
DZEVITSKII, B.E.	105	KOZERATSKAJA, G.N.	101
ENACHI, N.A.	51	KRUTITSKY, K.V.	95
FOWLER, M.M.	107	L'ABBÉ, C.	37
FRANK, K.	31	LIBERT, J.	75

Page numbers in boldface indicate first author

MACOVEI, M.A.	51	SADOVSKY, A.A.	45
MAKSYUTA, N.V.	17	SADYKOV, E.K.	53, 55
MANAPOV, R.A.	55	SAMARTSEV, V.V.	47, 49
MANDACHE, N.	31	SAMOYLOV, V.M.	41, 43
MEMELOVA, L.YA.	45	SAVEL'EV, A.B.	15
MITIN, A.V.	63	SAZONOV, S.B.	69
MOISEEV, S.A.	65, 67, 99	SEMENOV, V.G.	57, 105
		SERGEEV, I.A.	57
NAZAROV, V.M.	43	SHAKHMURATOV, R.N.	91
NEYENS, G.	37, 39	SKOROBOGATOV, G.A.	57, 59, 93, 105
NISTOR, M.	31	SOKOLYUK, I.V.	85, 87, 89
NOVGORODOV, A.F.	25	STRILCHUK, N.V.	103
ODEURS, J.	37, 39	TAYLOR, R.D.	107
OLARIU, A.	71, 73	TONCHEV, A.P.	25
OLARIU, S.	71, 73	TRET'YAKOVA, N.I.	45
PAN, Z.Y.	77	UDREA, S.	31
PAVLOV, S.S.	43		
PENACHE, D.	29	VAGIZOV, F.G.	55
PENACHE, M.C.	29	VASIN, A.V.	101
PERESEDOV, V.F.	43	VYSOTSKII, V.I.	13, 81, 83
PETRENKO, T.M.	101		
PILLET, N.	75	WILHELMY, J.B.	107
POINTU, A.M.	31		
POLITOV, V.YU.	23	YAKIMOV, S.S.	61
PONS, A.	75	YUAN, Z.S.	77
POPESCU, I.-IOVITZ	29, 31		
POTYLITSIN, A.P.	35	ZADERNOVSKY, A.A.	9
		ZAJAC, T.M.	85, 87, 89
QUENTIN, P.	75	ZAKIROV, L.L.	53, 55
		ZARETSKY, D.F.	69
RAD'KO, V.E.	43	ZHIRKO, YU.I.	101
REIMAN, S.I.	83	ZHU, L.J.	77
RIVLIN, L.A.	3, 5	ZORAN, V.	11, 29, 73
ROMASHEV, YU.A.	59, 93		
ROSTOVTSEV, YU.	79		
RUNDBERG, R.S.	107		