

AD \_\_\_\_\_

AWARD NUMBER DAMD17-96-1-6187

TITLE: High Resolution and Sensitivity Digital X-Ray Imager for Mammography

PRINCIPAL INVESTIGATOR: Darold Wobschall, Ph.D.

CONTRACTING ORGANIZATION: Sensor Plus, Incorporated  
Amherst, New York 14226

REPORT DATE: July 1997

**DTIC QUALITY INSPECTED 2**

TYPE OF REPORT: Annual

PREPARED FOR: Commander  
U.S. Army Medical Research and Materiel Command  
Fort Detrick, Maryland 21702-5012

DISTRIBUTION STATEMENT: Approved for public release;  
distribution unlimited

The views, opinions and/or findings contained in this report are those of the author(s) and should not be construed as an official Department of the Army position, policy or decision unless so designated by other documentation.

19971210 043

REPORT DOCUMENTATION PAGE			Form Approved OMB No. 0704-0188	
Public reporting burden for this collection of information is estimated to average 1 hour per response, including the time for reviewing instructions, searching existing data sources, gathering and maintaining the data needed, and completing and reviewing the collection of information. Send comments regarding this burden estimate or any other aspect of this collection of information, including suggestions for reducing this burden, to Washington Headquarters Services, Directorate for Information Operations and Reports, 1215 Jefferson Davis Highway, Suite 1204, Arlington, VA 22202-4302, and to the Office of Management and Budget, Paperwork Reduction Project (0704-0188), Washington, DC 20503.				
1. AGENCY USE ONLY (Leave blank)	2. REPORT DATE July 1997	3. REPORT TYPE AND DATES COVERED Annual (1 Jul 96 - 30 Jun 97)		
4. TITLE AND SUBTITLE High Resolution and Sensitivity Digital X-Ray Imager for Mammography			5. FUNDING NUMBERS DAMD17-96-1-6187	
6. AUTHOR(S) Wobschall, Darold, Ph.D.				
7. PERFORMING ORGANIZATION NAME(S) AND ADDRESS(ES) Sensor Plus, Incorporated Amherst, New York 14226			8. PERFORMING ORGANIZATION REPORT NUMBER	
9. SPONSORING / MONITORING AGENCY NAME(S) AND ADDRESS(ES) U.S. Army Medical Research and Materiel Command 504 Scott Street Fort Detrick, Maryland 21702-5012			10. SPONSORING / MONITORING AGENCY REPORT NUMBER	
11. SUPPLEMENTARY NOTES				
12a. DISTRIBUTION / AVAILABILITY STATEMENT Approved for public release; distribution unlimited			12b. DISTRIBUTION CODE	
13. ABSTRACT (Maximum 200 words)  Two previously developed x-ray imager technologies, the x-ray light valve and segmented digital imager are being combined into a larger area (8.5"x11.3") screen with high resolution (50µm) suitable for mammography. By applying current engineering devices and practices, a low noise image is expected. We expect to achieve the same size, resolution and image quality as film.  During the first year the overall image design was finished and a prototype of the CCD electronics and digital signal processor was tested.				
14. SUBJECT TERMS Breast Cancer  mammothpt.001 597  Digital Mammography			15. NUMBER OF PAGES 43	
			16. PRICE CODE	
17. SECURITY CLASSIFICATION OF REPORT Unclassified	18. SECURITY CLASSIFICATION OF THIS PAGE Unclassified	19. SECURITY CLASSIFICATION OF ABSTRACT Unclassified	20. LIMITATION OF ABSTRACT Unlimited	



High Resolution and Sensitivity Digital X-Ray Imager for Mammography  
Annual Report (July 1997)  
Darold Wobschall, PI  
Sensor Plus, Inc., prime subcontractor  
with InfiMed, Inc., Univ. of Toronto (Sunnybrook)  
and SUNY/Buffalo (ECMC)

Contents

Front Cover . . . . .	1
Report Documentation Page . . . . .	2
Foreword . . . . .	3
Table of Contents . . . . .	4
Introduction . . . . .	5
Imager Operation Summary . . . . .	8
Work Accomplished During First Year . . . . .	8
Imager and Screen Design	
Electronic Design and Testing	
Segmented Image Reconstruction Software	
Problems Encountered . . . . .	29
Task Schedule . . . . .	30
Statement of Work . . . . .	37
References . . . . .	39
Appendix A Description of Imager . . . . .	41
Appendix B Circuit Diagrams (Confidential)* . . . . .	43

\*sent separately

## Introduction

### Relevance\*

Screening mammography has been shown to be effective in increasing early detection and decreasing the mortality rate of breast cancer. Barriers to increased utilization of mammography include:

- Deficiencies in image quality and interpretation.  
A facility for image enhancement and improved contrast resolution through digital methods could decrease both false negative and false positive rates.
- Radiation risk.  
A reduction in the x-ray dose per mammogram would improve the risk versus benefit ratio and allow more frequent screening and at an earlier age.
- Cost and convenience.  
A decrease in cost and an increase in convenience would attract more women to the screening programs.

Digital x-ray images as a replacement for film are widely regarded as having excellent potential for reducing these barriers as evidenced by extensive research, development and commercial efforts underway. While regarded as the technology of the future, existing x-ray digital imagers do not live up to this potential because they require undesirable compromises between cost and performance goals. Cost aside, digital images also normally cannot achieve large area, and high resolution at the same time as low noise.

By combining the previously demonstrated segmented-image and selenium/liquid-crystal light valve technologies, we are developing (and expect to manufacture) a digital x-ray imager without the compromises which are characteristic of other digital imagers. Specifically we expect to achieve excellent spatial resolution, higher sensitivity, and superior contrast compared to film. Also the cost will be significantly lower than competitive digital imager technologies. System cost is expected to be less than film systems when image storage/retrieval/transmission factors, and especially the cost of misdiagnosis due to poor image quality, are taken into account. Thus we believe that we can achieve:

- Demonstrated full size image quality better than film/screen
- Convenience of digital imaging, including rapid viewing and image enhancement.
- Potentially lower x-ray dose per mammogram than film/screen
- Lower cost per mammogram

In common with other digital imagers, image enhancement/zoom capability, computer aided diagnosis, tele-radiography, and rapid image storage/retrieval are available options. Our stress will be an objective demonstration of high image quality resulting in clinical trials leading to FDA approval.

The major focus of this development is the reduction of observational and interpretational errors in breast diagnostics by providing high spatial resolution and significantly improved contrast resolution in the image, specifically through (1) an improved image acquisition (detector) system and (2) improved image processing.

In the more distant future, active element digital imagers may offer the performance goals stated here but in the near term we believe that this imager has the best chance of providing the desired cost and performance.

\*Modified from proposal

## Approach

A review of previous work on digital x-ray imagers related to our approach reinforced our view that feasibility had been adequately demonstrated through various working laboratory prototypes and that we needed to aim our efforts at a full-scale, full performance version. Reports of unsuccessful commercial attempts, and our own analysis, indicated that we would have to solve a series of difficult engineering problems to accomplish our goal. Thus we decided that for the first prototype, we would design and test only those parts of the system which had not been previously demonstrated rather than to fabricate a complete single channel as originally planned.

The main problems are these:

- Design of side illuminated x-ray light valve (XLV)
- Fabrication of full size XLV panel
- Imager geometry design, including segmentation and optics
- Charge Coupled Device (CCD) selection and circuit design (resolution and noise),  
together with low noise analog circuits
- Design of multi-channel parallel, digital signal processors (DSP)
- Software for alignment camera correction and seamless image segment reconstruction (stitching)
- Image data transmission to computer

After full-size, full-performance imager is made, the remaining tasks of complete testing and characterization (planned for the third year) will be addressed, in parallel with the development of an appropriate radiographic workstation software.

The original prototype of the XLV has transmission type optics such that the light passes through the liquid crystal (and Se) layers with front illumination (red light source). This geometry would be compatible with mammography only if the screen were moved from the patent area into a readout area immediately after exposure. Another possibility is to back illuminate the screen (suggested in the proposal). However, a third method, side illumination, was devised and is being pursued as the first option, with the other two methods as alternatives. This is discussed in the Imager screen design section of this report in detail.

The fabrication of the screen prototype, originally planned for the first year, was not completed because of a subcontractor (Litton) decision to stop production of liquid crystal displays, as described below.

The overall imager geometry design was completed, as described below. It consists of a 8x9 segment or tile array with an image size of 280x210mm (11.3"x8.5") and 50  $\mu$ m resolution. Image readout circuits, including the a/d, for the

selected CCD were designed. The electronics and optics for one channel was constructed and tested.

Low noise circuits with low electromagnetic interference (EMI) are difficult to design, especially in the restricted area of the imager. Without low noise circuits, the inherent low noise of the screen image will not be realized at the image readout. This is an iterative process, involving several printed circuit board layout trials.

During the first year a commercial DSP board was used to acquire the digital data. However the full size, multi-channel circuit for fabrication in the second year was designed since we found that commercial devices are both inadequate in performance and high in cost.

A major emphasis during the first year was the development of software for image reconstruction. We considered that previous methods were inadequate for mammographic images, especially the fine-scale microcalcification areas. Since we were uncertain how long this would take and wanted the software to be ready by the time the hardware (CCD circuit and DSP) were ready, this task was started early. It was largely successful although further refinement and testing is needed.

The transmission formatting and storage of data, after compression, from the DSP section to the readout computer or radiographic workstation will be accomplished by an adaptation of commercial software and hardware.

Development of the radiographic workstation software, to be done by InfiMed, has not been started and is not scheduled until the end of the second year when a full size image becomes available. InfiMed already has developed, and markets, radiographic workstation software for smaller size digital imagers and therefore this should not be a long process. Standard image processing software such as zoom and contrast enhancement are already in use.

Detailed testing of the imager with x-ray sources is scheduled for starting the second half of the coming year. Testing of components, such as the alignment grid and side illumination screen, have been done as needed.

## **Imager Operation Summary**

### **OVERVIEW**

The high resolution, high sensitivity, low cost x-ray imager is a combination of two innovative x-ray imager techniques previously developed by the participants, specifically the segmented imager screen and the x-ray light valve (XLV). The segmented approach allows multiple, standard CCD and optical components to achieve system high resolution. The XLV allows moderate cost, standard CCDs to be used without adversely affecting the sensitivity and noise level because the light level is determined by the optical source and not by the x-ray intensity. Additionally the XLV has a high resolution and contrast sensitivity which makes this technique particularly well suited for mammography.

The system consists of a blue LED light source, the XLV, optics, red light source, charge-coupled device (CCD) as the photodetector, data acquisition electronics, computer (with interface and software), and CRT display. The system being developed is the digital x-ray imager portion of a complete x-ray mammography instrument.

A detailed description of the imager is given in Appendix A.

## **Work Accomplished During Year**

### **IMAGER AND SCREEN DESIGN**

#### Design of Small Area X-Ray Light Valve (XLV)

The basic XLV design has been established. The key design parameters are liquid crystal type, which controls the characteristic curve of the XLV, the thickness of the layer, which optimizes the contrast ratio after the light color has been established. Further parameters are the twist angle ( $90^{\circ}$ ) and the tip angle (controlled by the way in which orientation grooves are made).

Figure 1 shows the cross-section of the prototype XLV. It is a sandwich structure composed of the following layers from the top down: a glass substrate with a transparent, conductive, Indium Tin Oxide (ITO) coating; a  $\sim 100\text{-}500\ \mu\text{m}$  thick *a*-Se layer; a  $1000\text{-}5000\ \text{\AA}$  thick polyamide (PI) alignment layer; a  $\sim 5\text{-}15\ \mu\text{m}$  thick LC cell formed by spacers for uniform separation between the substrates and doped noematic LC; and a bottom glass substrate with a conductive ITO coating and PI alignment layer. The two main steps in the manufacturing of the prototype XLV are the *a*-Se evaporation and the construction of an LC cell.

### 1. *A*-Se Evaporation

The *a*-Se evaporation for this project has been provided by the Noranda Technology Centre, Pointe Claire, Quebec. The *a*-Se is deposited on an ITO glass substrate by thermal evaporation. The substrate temperature is kept fixed at about  $50^\circ\text{C}$  throughout the process. The *a*-Se properties are optimized with dopants such

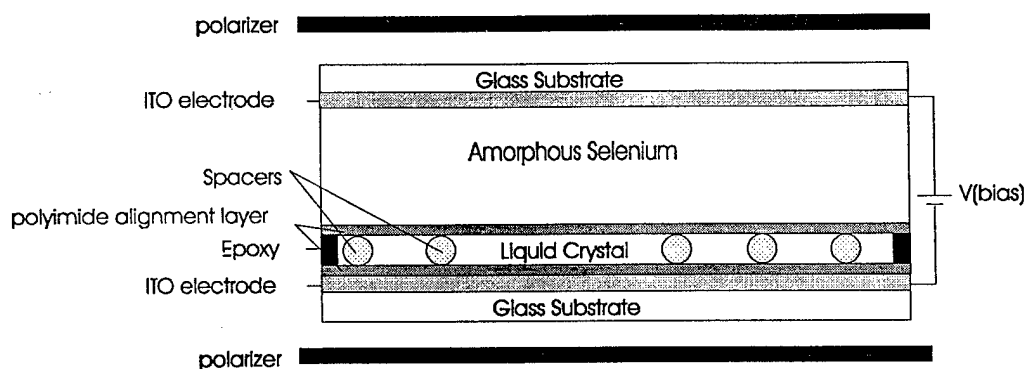

Figure 1 Cross section of x ray light valve.

as arsenic (As) and chlorine (Cl). Approximately 1 % As prevents *a*-Se recrystallization but decreases the lifetime of the charge carriers in the photoconductor which prevents efficient collection of signal charge. Parts per million of Cl are added to compensate for the adverse effects of the As dopant on the hole transport. We have ten 8" by 8" selenium-ITO-glass plates from Noranda. These have been cut to smaller pieces using a modified glass cutter.

### 2. Construction of the LC Cell

The LC cell for the XLV is constructed with a technique similar to building a

self-standing LC cell with the exception that the cell is defined by a glass and an *a*-Se

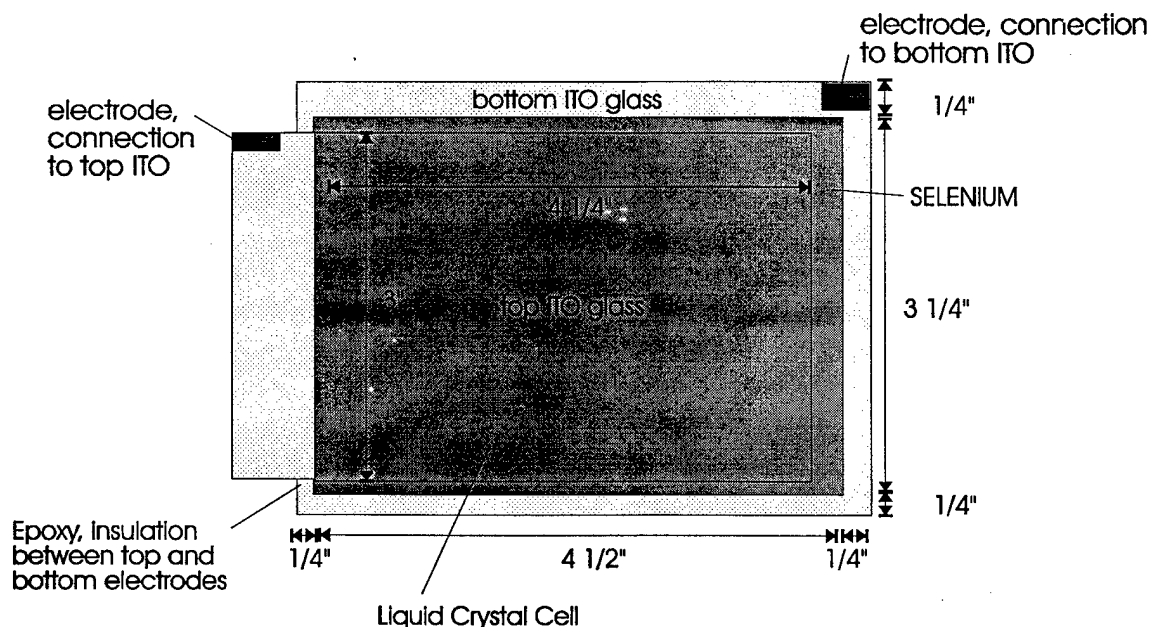

Figure 2 Top view of liquid crystal light valve prototype showing dimensions

substrate as opposed to two glass substrates. The use of a novel substrate poses additional restrictions on the construction process. The following outlines the LC cell process used in the prototype XLV construction.

The LC cell is constructed by a five step process involving preparation/doping of the LC material, substrate cleaning, deposition of an alignment layer, creation of the cell cavity, and vacuum filling of the LC cell cavity. To prevent contaminants from getting into the LC cell, work is performed within a clean environment, e.g. a laminar flow hood, as much as possible. The laminar flow hood creates a clean working environment by flushing the work space with constant flow of air which has been filtered to a very low particle count.

Liquid crystal molecules, within the confines of a cavity, will assume the lowest energy configuration defined by the boundary conditions, molecular elastic energy, electric or magnetic fields, and temperature. Operation of an LC cell in the 90° twisted noematic mode, requires the molecules in the absence of an electric field to align unidirectionally and in-plane with the substrates, and to acquire in-plane direction such that the orientation of the molecules twists by 90° from the top substrate to the bottom substrate. Such a helical molecular arrangement is obtained with deposition of an alignment layer on the substrates.

The alignment layer PI coating is performed both on the ITO glass plate and the *a*-Se plate. In each case, the substrate is fastened with vacuum suction to the

vacuum chuck of a spinner-coater. PI in solvent solution is introduced to the substrate on the ITO side of the glass plate or on the *a*-Se side of the photoconductor/glass plate. The substrate is spun (e.g. 50 seconds at 2000 rpm for  $\sim 3000 \text{ \AA}$  with a typical solution) to get rid of excess solution and to obtain a thin, uniform layer over the substrate. The PI coated glass plates would normally be cured for solvent removal at temperatures around  $200^\circ \text{C}$ . This is not possible with the XLV process as the *a*-Se photoconductor is known to recrystallize at temperatures above  $65^\circ$  and recrystallization drastically increases the photoconductor dark current. Thus the PI layer was cured at low temperatures. The decreased curing temperature was offset by the use of long curing time (at minimum a few hours) in an evacuated oven. After the oven cure, the PI coated plates are rubbed unidirectionally to create "microgrooves" for LC molecule alignment. The laboratory method of alignment simply involves rubbing the PI covered substrate with a low lint tissue wrapped around a sponge. The rubbing direction for the two substrates is chosen in such a way that when the plates are attached together to form the LC cell cavity, the alignment directions will form a  $90^\circ$  angle. This was not done during the first year but a similar process was done previously.

Investigation of properties of amorphous selenium layers was made to establish that the material was not damaged nor its imaging properties corrupted in the process of manufacture of the XLV. For this purpose a xerographic charging table was constructed. The charge table consisted of a motor driven stage (Unislide motor stage computer controlled via RS232 interface) to move an amorphous selenium plate from one station to another. The first station is a charging station where a corotron (a corona wire and screen with HV bias connection) is used to form a cloud of charged ions, and a screen to direct the ions onto the plate. The second station consisted of a surface potential electrometer (vibrating reed type) held close to the charged surface to monitor the potential achieved. The whole apparatus is controlled by a PC and coordinated by a Labview program. The potential readout is via a DVM connected to two electrostatic probes that are read alternatively with the help of a relay switch. The program starts the charge table and then collects from the two probes for a user specified length of time. The whole apparatus is enclosed in a light tight booth to prevent optical discharge of the plates.

The procedure was to obtain amorphous selenium plates from the manufacturer and test for charge acceptance (potential that plate can be charged to in the dark using a corotron) and dark decay (by monitoring the surface potential as a function of time after charging). A procedure was established so that first the charge acceptance and dark decay were used to select appropriate amorphous selenium plates. Then surface treatments of the plates were performed, and measurements remade at every stage to ensure that the properties were unchanged - or if they were changed then appropriate remedial changes in amorphous selenium processing were instituted. This procedure has been used and appropriate parameters for charge acceptance and dark decay established. The complete light valve is constructed to the dimensions shown in Figure 2.

## Testing of Light Valves

Methods for testing light valves have been previously established and a CCD camera obtained and interfaced to a PC. Methods for measuring MTF are based on the use of a slanted slit technique to avoid aliasing in the CCD. Also, appropriate relay lenses have been obtained to ensure that the size of the image of the slit on the CCD is magnified to the extent that sampling is adequate and no significant degradation can be ascribed to the pixel size of the CCD.

Measurement of Wiener noise power spectra are obtained with the same CCD and optics, but in this case viewing a blank (or uniform) field of view. Appropriate corrections to the image for CCD and field flatness are obtained for both MTF and noise power measurements by use of highly averaged uniform field images.

## Optics

For experimental purposes we need a readout light source with controllable wavelength and brightness to provide uniform illumination over large area. We previously used an integrating sphere but the output of this is limited in area to a circle of about 1.5" diameter. Light sources investigated included a lamp from photographic condenser, slide projector or a graphic arts exposure station. The latter provides uniform exposure of a chosen wavelength. It is about 20 cm x 10 cm x 10 cm box, usually suspended about 80 cm above the film to be exposed, which takes rectangular 2" x 2" optical filter for wavelength selection and can be operated with an exposure control timer to provide ms control of exposure length. It consists of a lamp, filter holder, 45° mirror and a diffuser housed inside a light tight box.

Several approaches to readout optics for a complete system have been designed and preliminary investigation of the feasibility of obtaining the necessary components has been initiated. The two most promising will now be discussed.

## Integrated Diffuser

The Integrated Diffuser approach is shown in Figure 3.

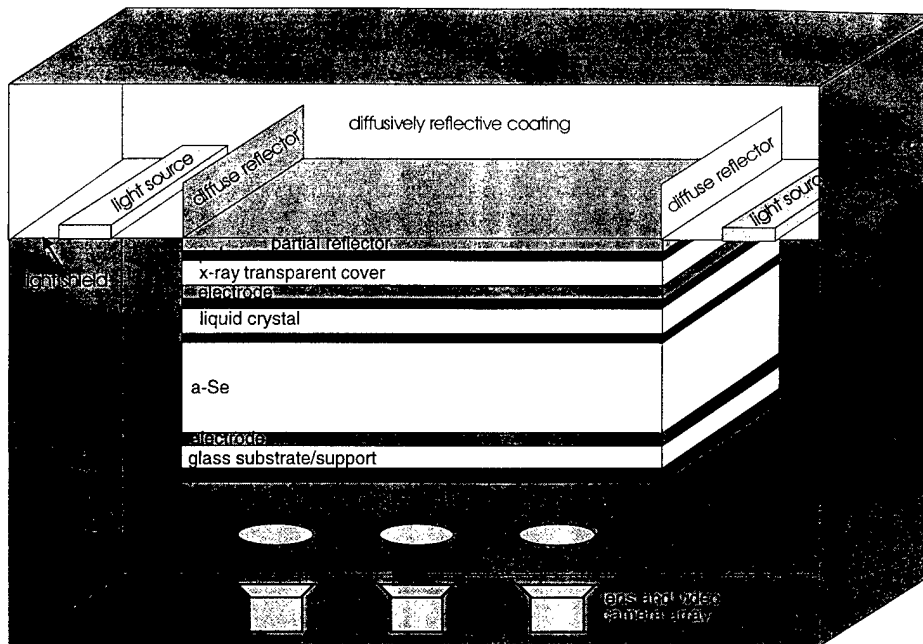

Figure 3 Integrated diffuser approach

**XLV CASSETTE:** All components include XLV, light source CCD array, optics and readout electronics are enclosed within one cassette structure that could replace existing film-screen cassettes of mammographic units. No movable parts. Internal optical shielding separates light source from readout.

**LIGHT SOURCE:** Various sources such as electroluminescent plates, LEDs etc., which can be made sufficiently small so as to not be bulky, could be used with appropriate red pass filters. The light sources is placed to the side(s) of the XLV, or even around the full XLV perimeter. The inner surfaces of the upper part of the XLV cassette would be coated with a diffusively reflective coating such as that found on the inside face of an integrating sphere. The entrance surface of the XLV could also be coated to be a partially reflector. Light would scatter within the cassette structure to create an uniform, diffuse illumination through the XLV.

**ADVANTAGES:** No moving parts, simple structure; XLV cassette can remain fixed in the mammography unit, quick flash exposure is possible, as easily usable for bias and readout lighting. We have chosen this approach for fabrication.

**DISADVANTAGES:** Careful design is required to ensure lighting uniformity: need to consider the angle of incidence on the XLV (would like this to be zero).

## The LC substrate as a Light Diffuser

This approach is shown in Figure 4.

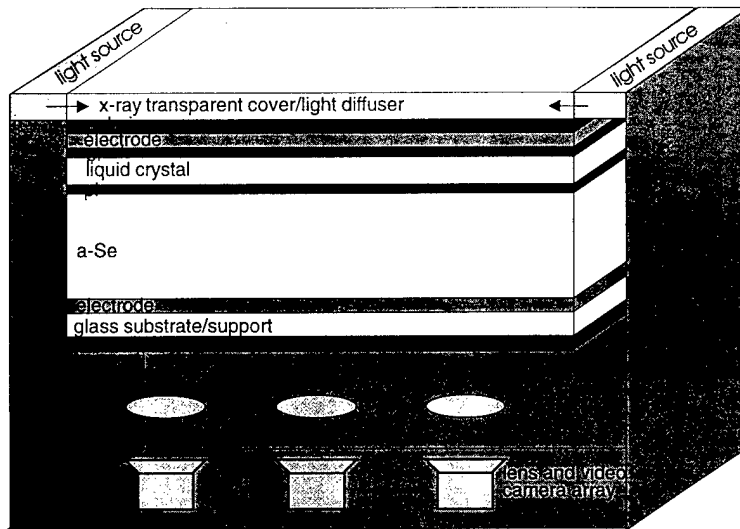

Figure 4 Liquid crystal substrate light diffuser approach

**LIGHT SOURCE:** Light would be directed into the LC substrate from the sides. The light would scatter within this substrate. The electrode could be made partially reflecting which would ensure multiple scattering events before the light passes out of the substrate layer in to the XLV.

**ADVANTAGES:** This method makes use of the substrate that is required for support as well as to distribute light. There are no moving parts.

**DISADVANTAGES:** Suitable substrate materials have to be found; placement of top polarizer and the incidence angle of light are issues.

## ELECTRONIC DESIGN AND TESTING

### CCD and Segment Size Selection

The selection of the CCD required a cost-performance analysis involving the electronic and optical components as well as the CCD. Larger CCDs (larger area and more pixels) are simpler to use because there are fewer parts but the cost rises rapidly with size, a longer time is required to read out the data from the CCD, and the optical system becomes larger, less efficient, and more costly. In any case segmentation is needed and the design problem is to find the optimum array image segment (tile), and CCD sizes.

We chose an 8x9 array with 24x36 mm segment size and CCD (Kodak KAF0400) with 9  $\mu\text{m}$  square pixels.

There is one lens for each CCD and each images a rectangular segment of the screen (XLV) or tile, plus an overlap. The larger the area, the further back must the lens be placed, resulting in an increase in imager thickness, which we consider undesirable. Furthermore the larger the area, the better the required lens quality (and higher the cost) must be in order to achieve the target 25 $\mu\text{m}$  resolution on the XLV screen. Finally, a lens covering a wide area must have a high demagnification, and in this case the light transmission becomes very low [20]. While the light intensity with our XLV screen is much higher than the usually x-ray screen, a low light level will adversely affect the noise level. Moderate amounts of lens distortion (pin cushion) are tolerable and chromatic aberrations are unimportant because the illumination is nearly monochromatic (red). Thus a fast (short focal length or low f-number) lens is best for this application. To achieve optimum performance a custom-designed lens was fabricated by J.A. Optics Inc., an outside vendor and optical consultant. It has a focal length of 8 mm and f# of 1.3. At an object distance of 36 mm, the demagnification is 5.6. It is intended to image the 24x36 mm screen segment onto the 5.5x8.4mm active area of the CCD.

An outline of the imager geometry showing the segmentation is shown in Fig. 5. The optics for a one segment (lens and CCD) is shown in Fig. 6.

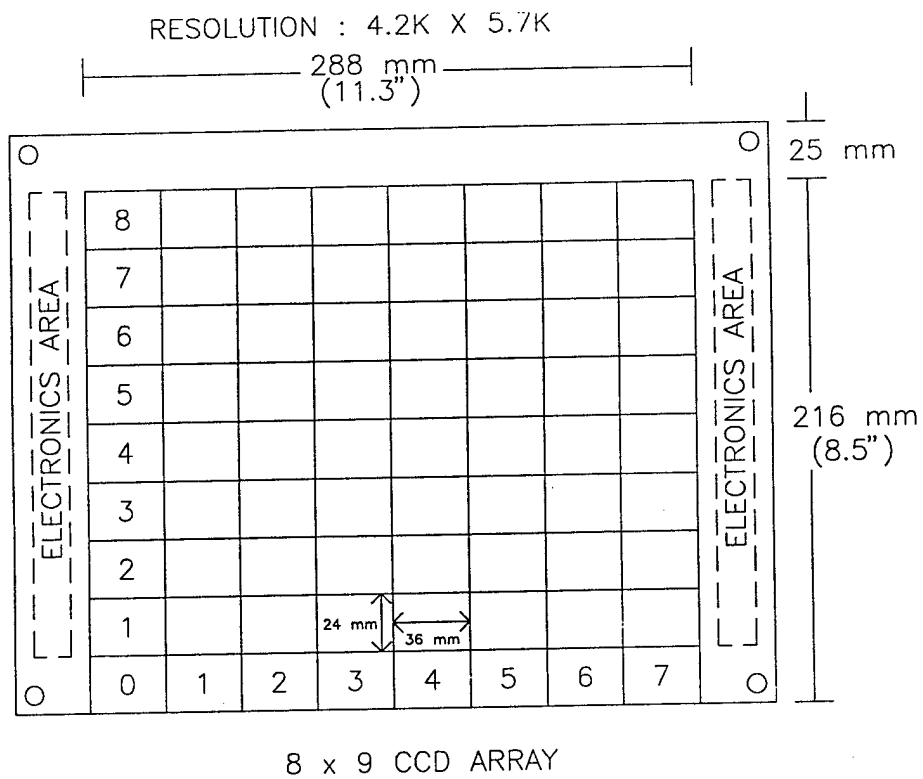

Fig. 5 Full Size Imager Geometry

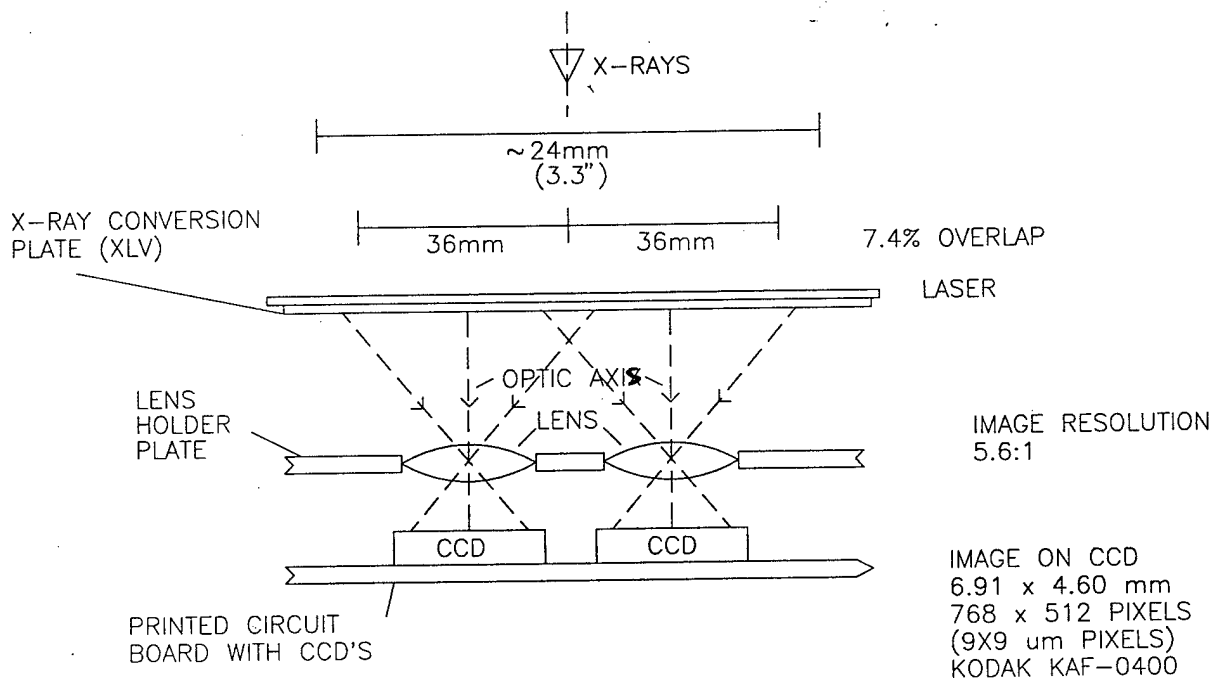

Fig. 6 Optics for One Segment

A scientific grade CCD (Kodak KAF0400) was chosen over the commercial (video camera or TV grade) because the response of each pixel is more uniform and less noisy for this type of device. The size selected (512x768 pixels, 9  $\mu\text{m}$  square) is the smallest and lowest cost (\$100 to 400) of this series. While capable of a data rate of 20 meg pixels per second (MPS) we using it at a data rate of 2 MPS to minimize noise.

Pixel noise is 20 e (rms) which, when combined with a full scale (well capacity) of 85,000 e, results in a dynamic range of 72 db. It should be noted that a 12-bit a/d resolution corresponds to a 72 db dynamic range so that we consider this device well matched to our system requirements. The device is also very sensitive (quantum efficiency over 30%) although this is not a critical parameter for our system.

The next large size (1k x 1k) which would have a corresponding by larger segment size, but smaller number of segments, was also considered but was rejected because of higher system and development costs. Trends in component prices suggest that the size may be more optimum in the future.

### Packaging and System Geometry

As indicated in Fig. 7, the imager screen, optics, CCDs and signal input electronics are to be placed in a relatively compact package or module. This module replaces the film cassettes on the x-ray machines (Fig. 8). It has roughly the same area but is thickener.

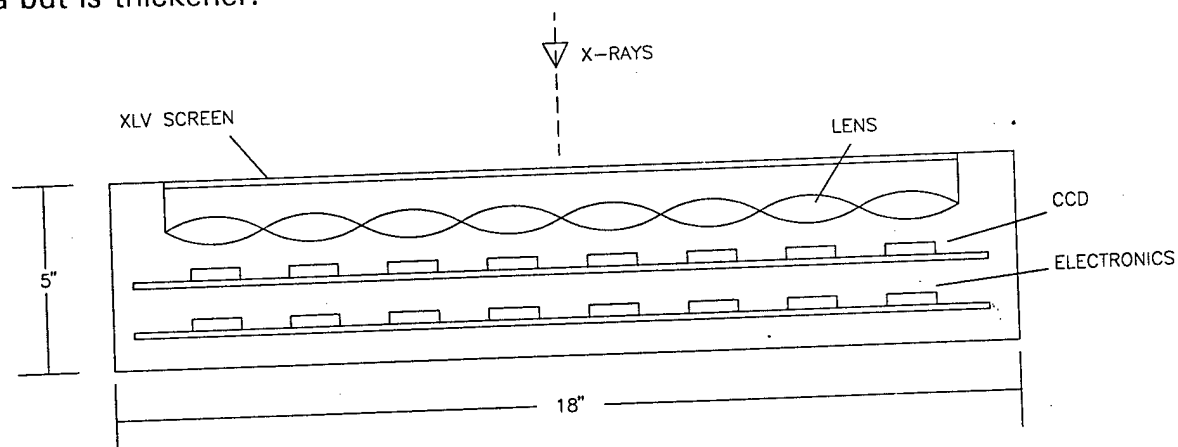

Fig. 7 Imager Module Geometry

Only the CCD electronics and low-level analog signals, including the a/d, are in the imager module. The DSPs, which do the major part of the signal processing, are in a nearby cabinet mounted on the x-ray source support post. A large cable runs from the imager module to the digital signal conditioner electronic box. A smaller cable runs from this box to a readout computer (e.g. Pentium PC) which may be some distance away.

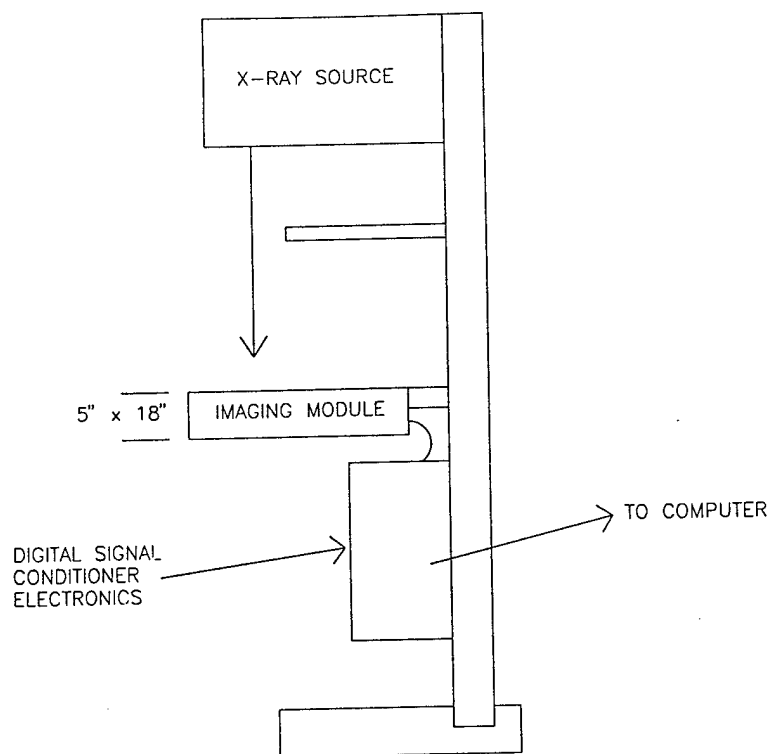

Fig. 8 Mammographic x-ray showing imager module and electronics position

#### CCD Electronics, including A/D

Because the CCD evaluation board available from Eastman Kodak was unsuitable for this project in many respects, including size, we designed our own circuits and fabricated our own circuits for testing. CCD clock signals were generated by the combination of a small microcontroller (PIC 16C54) and programmable logic device (PLD). These circuits are given in Appendix B. In the next prototype, the DSP will supply the necessary pulses to the PLD.

Clock drivers, based on high speed op amps, provide the non-standard voltage level pulses required by the CCD. These were designed to be suitable for arrays of CCDs. The signal output of the CCD requires a dual sample-and-hold circuit, termed a "correlated double sampler or CDS" to extract the desired video signal relative to the baseline. Conventional CDS chip intended for TV applications do not have the stability required of a high resolution (12-bit) system. Therefore we have developed and tested our own circuit based on two high performance sample-and-hold commercially available integrated circuits.

We have chosen a higher speed, moderate cost A/D capable of 12-bit resolution at 2 MHz, our chosen clock speed and pixel output rate. Latches at the A/D output convert the data stream, together with four status lines, to two 8-bit words at 4 MHz

for transmission to the DSP. The detailed circuits are given in Appendix B (confidential).

A constant concern in the design of this analog section is the minimization of electromagnetic interference (EMI), particularly noise produced by the digital signals (clock signals and a/d output) due to the close spacing of the CCDs required by the segmented optics geometry and the wide dynamic range requirement (12-bit or 72 db). Our first prototype, which was intended to test circuit function without any concern for noise, has only a 5-bit dynamic range due to the noise. The layout of the printed circuit of the next prototype (2x4 array) is intended to be low noise/EMI and thus will be a high resolution (but not full size) prototype.

### Prototype DSP Hardware Development

The initial research for overall choices of hardware architectures for the final prototype device was completed. As per the original proposal, a parallel digital signal processing (DSP) architecture was designed to accommodate all the required image processing tasks including:

1. Pixel-by-pixel intensity normalization.
2. Lens distortion correction
3. Registration of segmented CCD image sections
4. Loss-less compression
5. Image data transfer to workstation

The block diagram of the parallel DSP including the workstation interface is shown in Figure 9.

We found that the best suited DSP to achieve all the proposed tasks is the TMS320C40 parallel DSP. This DSP contains all the necessary parallelism, data throughput, and inter-processor communication hardware to allow easy control and processing of the large image data sets.

A single CCD portion of the CCD-array and analog electronics were designed and fabricated. The CCD chosen contains 768x512 resolution so that the overall resolution for this prototype is 1536x1024. The block diagram in Figure 10 shows the layout of the CCD and analog processing electronics.

# Single DSP Block Diagram

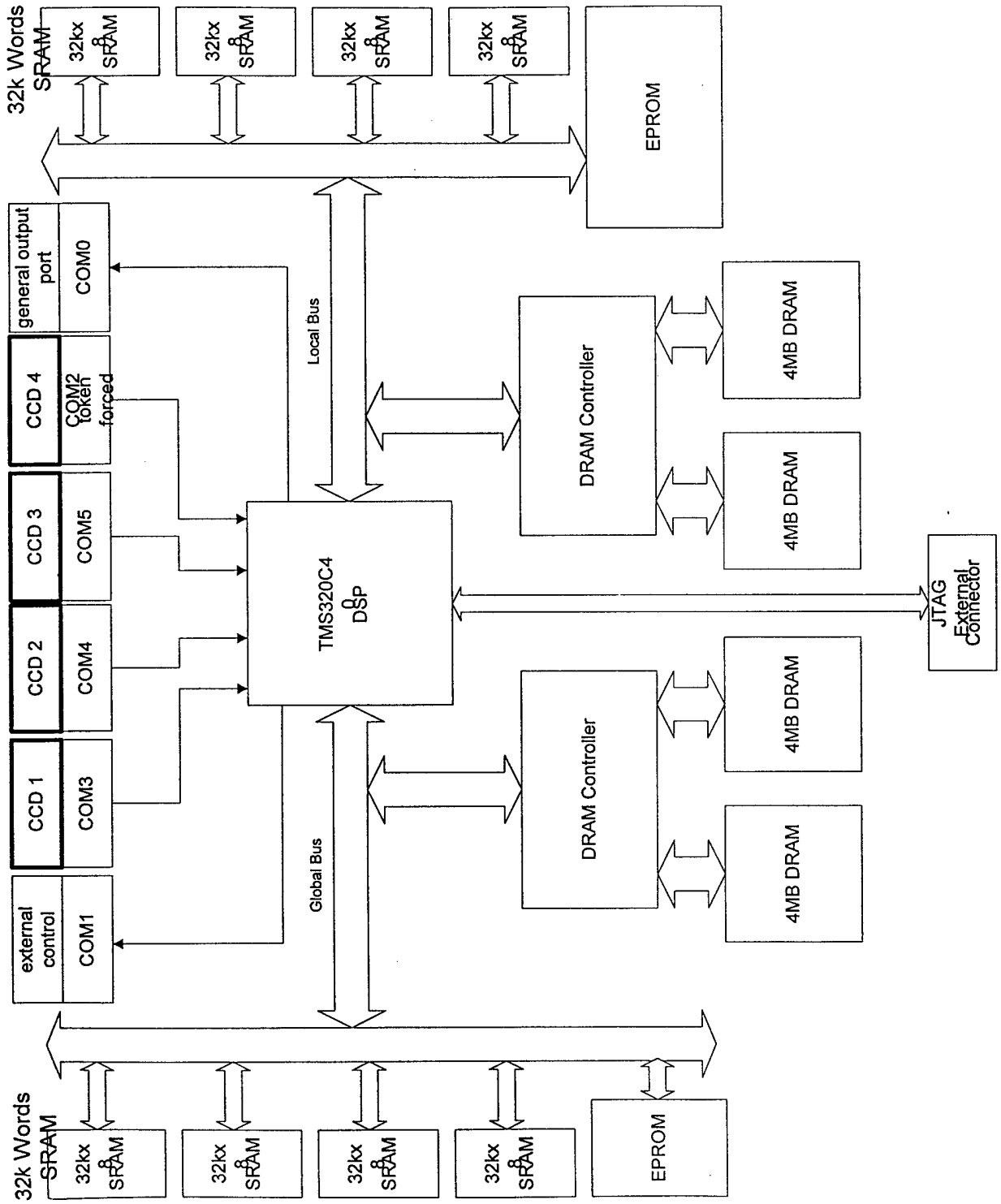

Fig. 9 DSP Block Diagram

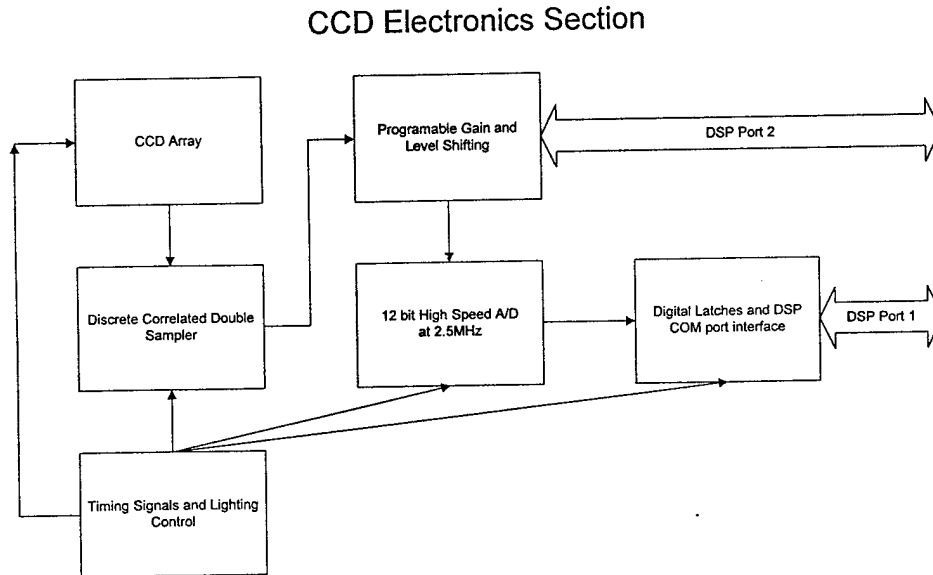

Fig. 10 Block Diagram of Analog Section

The development of the low resolution prototype (single DSP with 4 CCD-arrays in a 2x2 mosaic) based on the above parallel design, is currently being laid out. The block diagram in Figure 11 shows the layout of the single DSP system with the CCD-array connections. Even though the DSP portion of prototype 1 is essential to testing, the final design is not needed to test the CCD electronics section, these

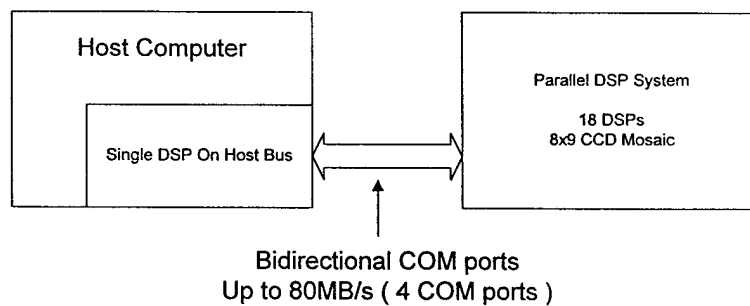

Fig. 11 DSP/Host Communication Block Diagram

sections are de-coupled. This allows us to use a commercially available DSP development system to complete all the CCD testing until the DSP design is not complete. These circuits are currently undergoing PC board layout.

The electronics have been functionally tested, and modified several times. It is being tested using our TMS320C40 development system with a PC computer. We are able to get preliminary images from the CCD electronics but these are not of high quality.

Current problems being addressed with the CCD electronic section are:

- Possible non-linear response of CCD
- Exposure time and light biasing
- Overall noise issues

We are currently revising these electronics to achieve better noise performance as well as fully integrating programmable exposure, light biasing, and analog signal biasing to reduce non-linearity.

A lens was designed and fabricated specifically for the array 8x9 array geometry. One lens was fabricated. A lens mount with a strobed LED light source was constructed for testing purposes. We are currently designing a lens mount for 4 of these lenses that will cover the 2x2 array, to be implemented on the next revision of the CCD electronics.

The following hardware support software has been implemented on the DSP using our TI development system:

1. Multiple image acquisition to memory
2. DSP to PC file I/O
3. Memory management and simple loss-less data compression
4. Camera correction algorithm was ported to DSP
5. Direct PC to DSP host interface driver to allow "real-time" display update of images

The TMS320C40 DSP has enough arithmetic and data throughput power to run the above tasks in the proximity of the times originally proposed.

## SEGMENTED IMAGE RECONSTRUCTION SOFTWARE

The digital mosaic mammography device relies upon using various image processing and analysis techniques to generate a digital mammogram using an array of smaller size CCD imaging sensors. During the period covered by this report, the primary objective was to develop methods which would acquire images using four CCD cameras, correct any distortions undergone by the individual images and "stitch" these images to form a larger images. Towards this objective, main focus was on developing techniques that accurately corrected image distortions and on suitable techniques for image stitching.

### Correction of Image Distortions

As an image is acquired by the CCD, through a lens, the digitized image will undergo some optical and sensor-dependent distortions relative to the original image. Any distortion correction scheme must provide the necessary corrections, so that the discrepancy between the digitized image and the original image is medically insignificant. In general, however, comparison between the original and digitized images cannot be carried out, since only the later is available on the computer. In order to overcome this difficulty a test pattern is used to establish a correspondence between the original and digitized images and estimate the correction parameters. These parameters are used to correct any subsequent images acquired by the system.

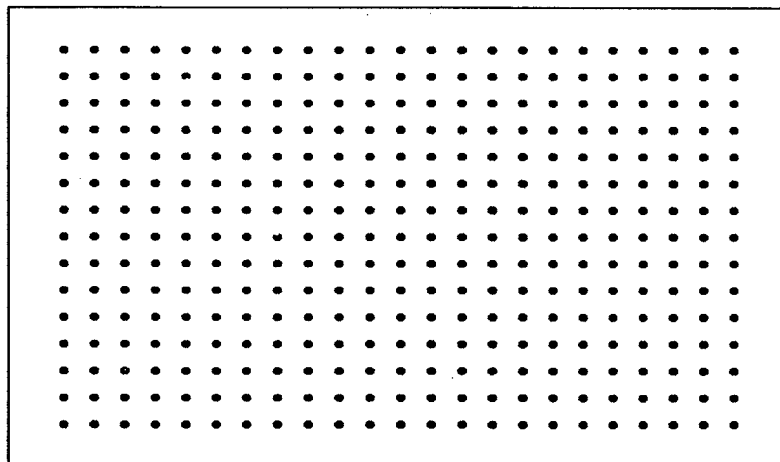

Figure 12. Test pattern. A. Computer-generated version, E

The test pattern developed to carry out distortion correction is shown in Figure 12. The dots on the pattern are called control points. Distance between the control points on the original image is precisely known a priori. Therefore by computing the distance between the control points in the digitized image, it is possible to obtain a measure of the distortion introduced by the acquisition process. Once the distortion parameters are computed, a algorithm that implements an inverse distortion transformation is developed. This algorithm is applied to any images acquired subsequently. Figure 12 shows the procedure graphically. It should be noted that the precision with which the distortion can be computed is directly related to the accuracy with which the distance between the control points in the digital image can be computed.

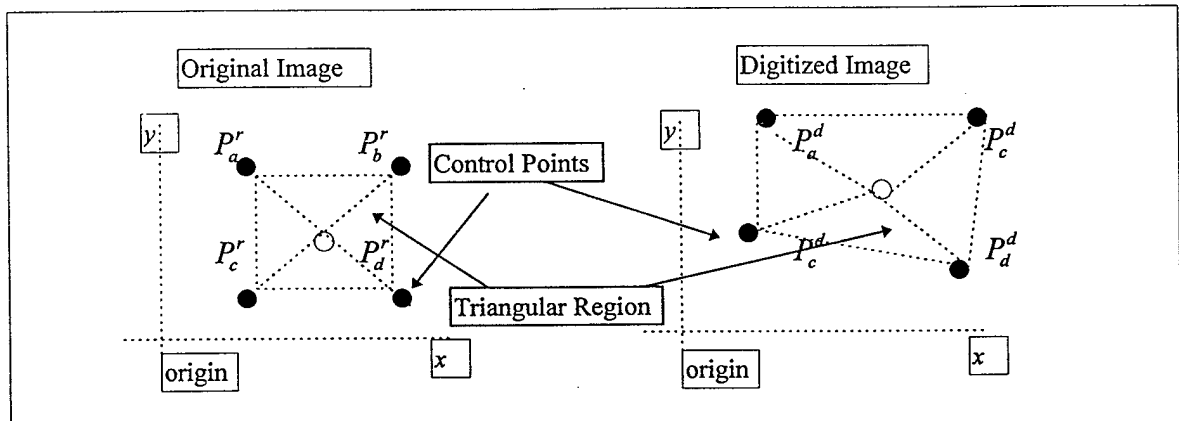

Fig. 13 Control points in the digitized image provide one-to-one mapping to control points in the original image. The rectangular region enclosed by the control points is sub-divided into four triangles to improve accuracy. The central control points coordinates are an average of the four coordinates.

The x-ray visible test pattern (Fig. 12B) was made by applying a silver-based ink of the type used for "hybrid" printed circuit boards onto a glass plate using a precision, direct-writing process developed by Ohmcraft, a sister company of Sensor Plus (F. Collins is President of both). The precision is sufficient to allow correlation of a control line to a fraction of a pixel width for a pattern of the final image size (8.5

x 11.3 inches).

Control points in the digitized image Figure 13 provide one-to-one mapping to control points in the original image. The rectangular region enclosed by the control points is sub-divided into four triangles to improve accuracy. The central control points coordinates are an average of the four coordinates.

### Stitching Algorithm

A digital image mosaic is formed by stitching all the corrected digitized images obtained by each individual CCD. Each individual CCD covers one section of the entire image. Some parts of the complete image are observed by multiple CCDs since this is an overlap region between neighboring CCDs. Overlap is necessary since no part of the image on the XLV screen can be omitted or a clinically relevant feature may be missed. The stitching algorithm must remove the overlapped regions and the regions observed solely by each CCD and combine these to form the complete mosaic image.

When imaging the test pattern, given the CCD array positioning geometry, it is possible to know a priori the number of control points in the overlap region of neighboring CCDs. Figure 14 shows a control line, used to delineate the transition between control points which belong solely to one CCD and those that are observed by neighboring CCDs. Therefore by storing the coordinates of the control line the stitching algorithm can be applied to any arbitrary image. Note that the accuracy with which the images are stitched is depended on the accuracy with which the control line can be defined.

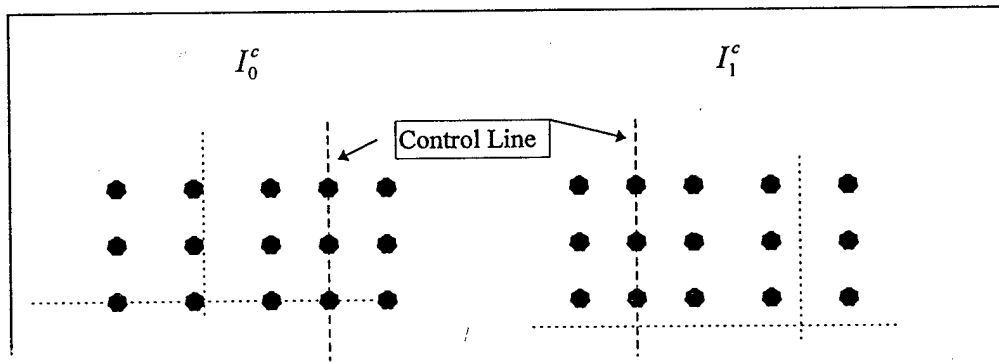

Figure 14: Adjacent images are stitched together at the control line.

### Implementation

The hardware for acquiring four CCD images was not ready by the time the software was developed and tested. Therefore the algorithms and techniques described above were carried out under simulated conditions and these results are presented. In the simulation, the test pattern of Figure 12 was created in the computer. The pattern was segmented in four overlapping regions. An algorithm

simulating barrel distortion was applied to each of the segments. It is assumed that distortions undergone in reality can be characterized appropriately using the barrel distortion model. The distortion correction technique was applied to the distorted segments.

The algorithm automatically detects the control points and computes distances on both original and distorted images. An inverse model of the distortion is computed and applied to the distorted segments. Once each of the four segments are corrected, the control line is computed and finally the images are stitched back together to obtain the mosaic image. Figure 15 below shows the steps described above. In Figure 15a the original overlapping segments are shown. Figure 15b shows the segments after the barrel distortion is applied. Figure 15c shows the images after distortion correction algorithm is applied. Finally in Figure 15d the reconstructed mosaic image is shown. The entire procedure was carried out in less than 30 seconds on a Pentium 100 based computer. It will be much faster on the specialized DSP hardware being developed.

The distortion correction parameters computed for the test pattern were used to correct a digitized mammogram image. Notice that this simulates the case where an arbitrary image is acquired following the computation of all required parameters. The mammogram in Figure 16 was obtained by digitizing a film mammogram using a generic 600 dpi gray scale scanner. Next, the digitized image was segmented into four overlapping regions as shown in Figure 16. The distorted images in Figure 16 were obtained by applying the barrel distortion algorithm used above to the segmented images. The corrected images are shown in Figure 16. These corrected images were obtained by applying the inverse transformation computed on the test pattern to the distorted images. Finally the stitching algorithm was used to reconstruct the entire mammogram as shown in Figure 16. Notice that the correction and stitching parameters are computed only on the test pattern, and are applied to any arbitrary image that has undergone similar distortion as that undergone by the test pattern.

### Discussion and Future Work

The simulation results indicate that the methods developed perform very well. Under varied simulated distortion conditions, it was observed that the mean squared error between the original image and the mosaic reconstruction was only 3% under extreme conditions. However, when applied to mammography data the 3% error was further reduced and there is no seam or distortion can be seen on the computer screen, even when magnified. The stitching algorithm played a significant role in the overall error. The dot test pattern of Figure 12 is appropriate for four CCD but when a larger array of CCDs is used, this pattern may be inadequate. Therefore a more complex pattern and further improvements will be needed.

The following issues will be addressed in the period starting August 1997 to July 1998:

- + Testing of the techniques developed on the multiple CCD hardware prototype.
- + Development of a larger test pattern suitable for a large array of CCD.
- + Testing of the techniques developed with the new pattern.
- + Refinement correction and stitching techniques.

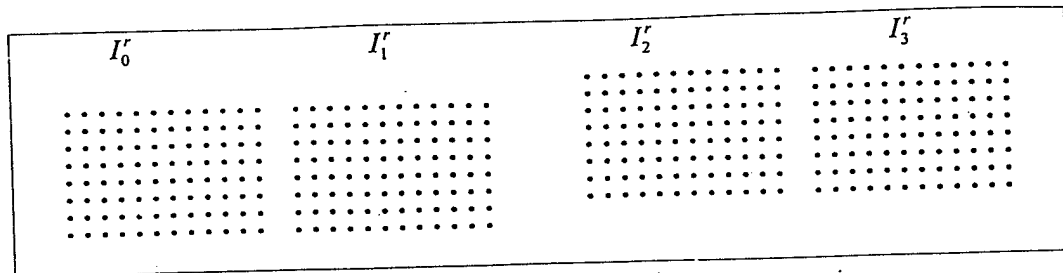

a: sub-images extracted from the test pattern of Figure. 1.

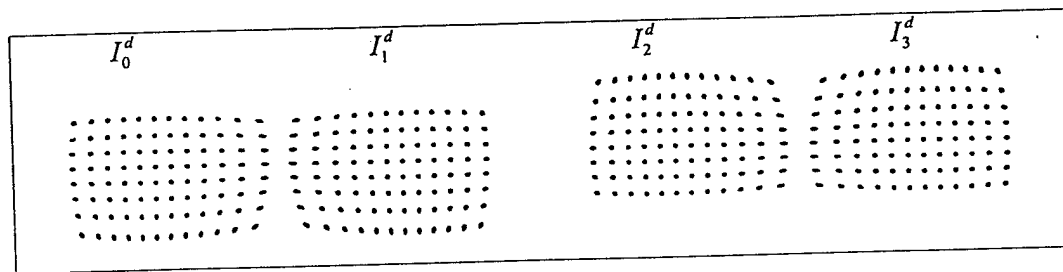

b: distorted images obtained using a barrel distortion.

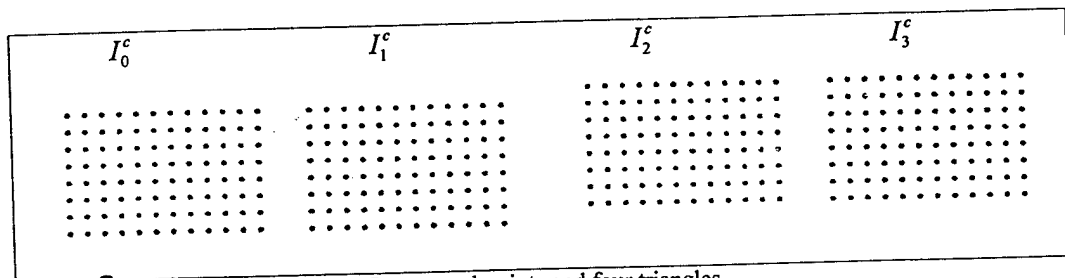

c: images corrected using five control points and four triangles.

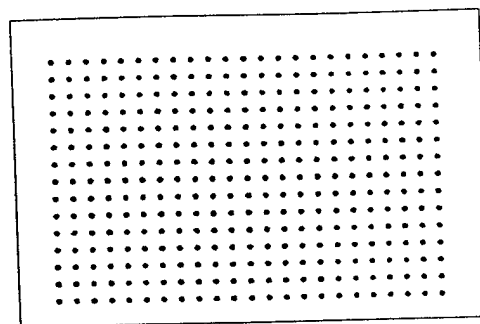

d: digital mosaic image obtained after stitching the  $I_k^c$  images ( $k=0..3$ ).

Figure 15 Sub-images extracted from the test pattern of Fig. 12  
 b: distorted images obtained using a barrel distortion.  
 c: images corrected using five control points and four triangles.  
 d: digital mosaic image obtained after stitching the images ( $k=0..3$ ).

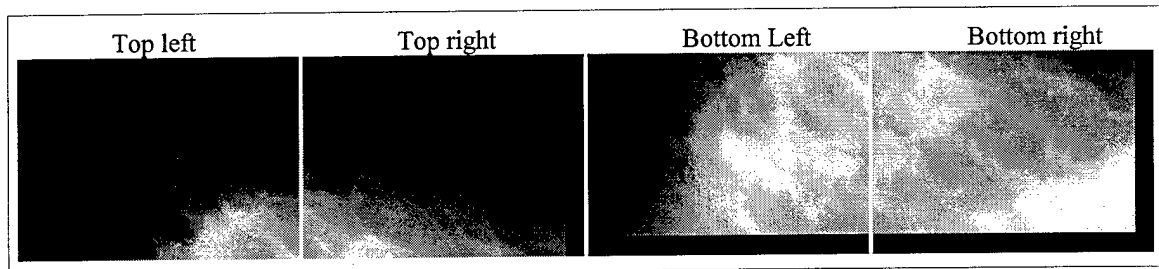

5.a: Sub-images extracted from a mammogram of size 512x768.

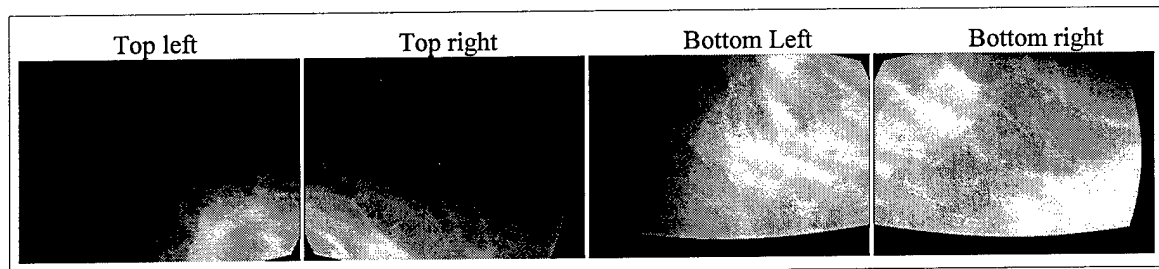

5.b: distorted image obtained using barrel distortion.

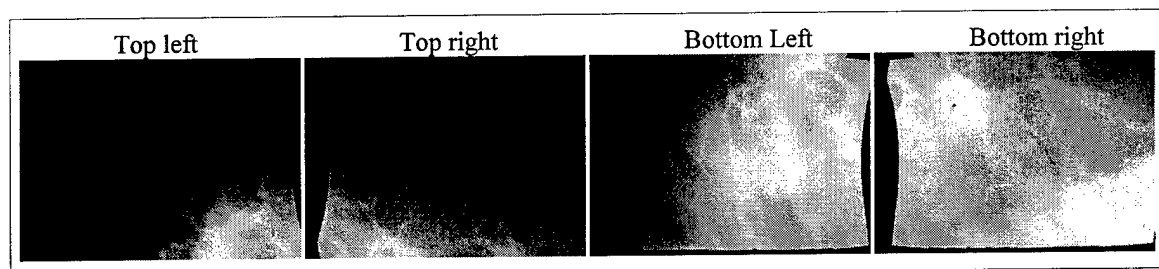

5.c: images corrected using the distortion corrected model computed on the test screen

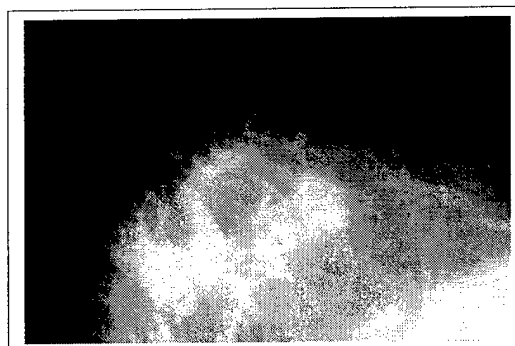

5.d: digital mosaic image obtained after stitching all the images in Figure 5.c.

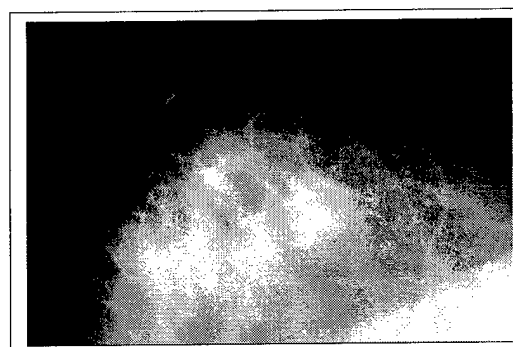

5.e: original mammogram.

Figure 16 Simulated Sub-images taken from a film mammogram of size 512x768.

## Problems Encountered

One set back was the resignation of Litton Canada from the project. They were to fabricate the selenium/liquid crystal x-ray light valve screen. After a series of delays Litton announced that their entire liquid crystal display division was to be closed. Also the individuals involved with this project (B. Bahadur and R. Ruta) were terminated. Fortunately a key component, the amorphous selenium plate, was done by another subcontractor and was delivered (now at Sunnybrook/U. Toronto). Dr. Rowlands is arranging an alternate liquid crystal supplier or for fabrication in the clean room of the U. Toronto. No money was paid Litton and therefore this is a schedule setback but not a financial setback. We have changed our schedule to accommodate this.

The selection of imager geometry required longer than expected, thus delaying somewhat the overall (side-illuminated) design, completion as well as the prototype fabrication and testing. Although not unexpected, the trouble-shooting for noise reduction of the analog part of the circuit (CCD, CDS, A/D) is taking a long time.

On the positive side, the image processing software is ahead of schedule. Furthermore, because we are taking advantage of the recently introduced higher speed digital signal processor (DSP) components and lower cost memory, the entire image reconstruction can now be done by the imager DSP rather than transferring a portion of the image signal processing to the workstation. Also the development of the data bus drivers for transfer of the image to the workstation is taking less time than expected. This will significantly reduce the time required to develop the workstation software scheduled for later.

## TASK SCHEDULE

The task schedule has been revised into the following tasks.

### Task 1. Build Prototype (low resolution)

#### A. Fabricate Small Area X-ray Light Valve

A XLV with a size between 80 x 80 mm (3x3 inch) and 200 x 200 mm (8 x 8 inch), will be fabricated. The device will be similar to that previously made.

#### B. Test of X-ray Light Valve

The XLV fabricated above will be characterized by Sunnybrook and methods of improvement suggested. A moderate resolution of 3 > to 10 lp/mm is anticipated.

#### C. Fabricate Optics\*

The optical system was fabricated by Sensor Plus subcontractors. Segment area is 24x36mm and the array size is 2 x 2 initially, and then 2x4.

#### D. Electronics Computer, and Interface\*

A new design for the CCD input electronics and a/d converter was devised, and fabricated. One CCD channel was tested.

#### E. System Test

The system response will be measured at SUNY/Buffalo (ECMC) using phantoms.

### Task 2. System Design

#### A. XLV

The XLV side illumination screen was designed by Sunnybrook.\*

#### B. Optics

The optics was designed by Sensor Plus and J.A. Optics, a subcontractor.\*

#### C. Video Data Acquisition and Interface

The electronics is being designed by Sensor Plus. One channel is being tested, further versions are planned.\*

\*completed first year

D. Image Reconstruction Software

The reconstruction software was done Sensor Plus.

E. Radiographic Workstation Software

The radiographic will be designed by InfiMed.

F. Adapt to x-ray Unit

The Bucky grid and interface will be added to a commercial x-ray source by SUNY/Buffalo.

G. Test Methods and Equipment

Test methods and equipment will be planned by SUNY/Buffalo (ECMC).

Task 3. Fabricate and Evaluate Small Area, High Resolution Prototype

A. Fabricate Hi-Resolution X-ray Light Valve (XLV)

An improved XLV will be made by a subcontractor to be determined. It will have a resolution over 15 lp/mm in an area of 80x80 mm or larger.

B. Test of XLV

The high resolution XLV will be characterized by Sunnybrook (as above) and methods of improvement suggested, as required.

C. Fabricate Optical System

Based on the results of Task 1, design the final optical system (including case and mounting) and construct a portion (2 x 4 array) at Sensor Plus. It will have provision for, but not include, the tilt plates needed to improve the resolution to 25  $\mu\text{m}$ . Preliminary tests will be done with the Task 1 prototype.

D. Fabricate and Test Video Electronics Section

One segment of the video data-acquisition system consisting of the CCD, analog input, 12-bit A/D and digital signal processor has been designed, constructed, and tested. It was done on a printed circuit board with the same size as the final, multi-segment version. The memory will be sufficient for the 25  $\mu\text{m}$  image but the software will be written for the nominal 50  $\mu\text{m}$  pixel. The objective is to demonstrate that the effective noise level does not exceed 2 LSB out of a 12-bit full scale range.

E. Fabrication and Test of Workstation Interface

The control (DSP or microprocessor) which combines the outputs of the individual DSP segments and transfers the data in a block to the computer (workstation) will be fabricated.

The tests will include a checkout of the workstation hardware and basic software. Software from the previous DOS-based system will be converted to the workstation and tested.

F. Test of Imager Segment

The performance of the imager will be tested at SUNY/ECMC using phantoms with a stress on resolution contrast sensitivity and noise measurements.

Task 4. Fabricate and Test Full Size Imager

A. Fabricate Full Size, High Resolution XLV

The XLV similar to that made in Task 3A will be fabricated except that it will be full size (8.5" x 11.5") and will incorporate improvements indicated by previous testing.

B. Test of XLV

Tests similar to Task 3B will be made by Sunnybrook.

C. Fabricate Optical System

The optical system will be designed by Sensor Plus, based on the results of Task 3C, and fabricated by outside vendors.

D. Fabricate Image Acquisition Electronics

The final size printed circuit boards will be laid out, built and tested at Sensor Plus. The DSP software will be programmed at Sensor Plus.

E. Refinement and Test of Image Processing Software

Two high performance Pentium computers will be purchased (one at InfiMed and one at Sensor Plus). The image transmission software between the DSP and computer will be tested by Sensor Plus and InfiMed.

## Task 5. System Performance Test

### A. Test of Imager

The imager will be tested at SUNY (ECMC) using phantoms and specimens for Roswell Park Cancer Institute RPCI if appropriate. In addition to resolution and noise, image distortion or discontinuities between segments will be examined.

### B. Comparison with Film

Standard x-ray films images will be compared (at ECMC) with those obtained by the imager under development. The objective is to demonstrate that no artifacts exist.

### C. Clinical Trial Planning

Planning for future clinical trials will be made primarily by SUNY (ECMC) and the consultants.

## Task 6. Preparation, Radiographic Workstation Software

### A. Implementation of Standard Viewing Software

Software features required by users will be implemented by InfiMed.

### B. Verification of Image Quality Robustness

Tests will be made at SUNY (ECMC) to verify that the image quality is not effected by improper software sequences.

### C. Environmental Tests

Tests will be made of the image quality under moderate vibration, humidity, and temperature variations by Sensor Plus and InfiMed.

### D. Image Compression

A method of image compression and storage will be selected and implemented at InfiMed.

### E. Display Tests

The quality of the display will be evaluated at InfiMed, SUNY (ECMC and RPCI).

## Task 7. Implementation and Test of Double Resolution Sampling Feature

### A. Fabricate Tilt Plates

The tilt plates (Fig. 17) and electronic drivers will be fabricated and tested using first the small area imager (Task 3) and then the full area (Task 4). Also the software needed to capture the shifted images will be prepared.

### B. Test with Optical Targets

The resolution will be tested using a transparent film test pattern with features as down to  $10\ \mu\text{m}$  in size. The resulting reconstructed images will be verified with the known pattern.

### C. System Test

A test of the system with the XLV and x-ray source (using phantoms) will be made. The objective is to verify the  $25\ \mu\text{m}$  spatial resolution, and high contrast resolution, over the full image areas ( $8'' \times 11''$ ).

A schedule of tasks follows:

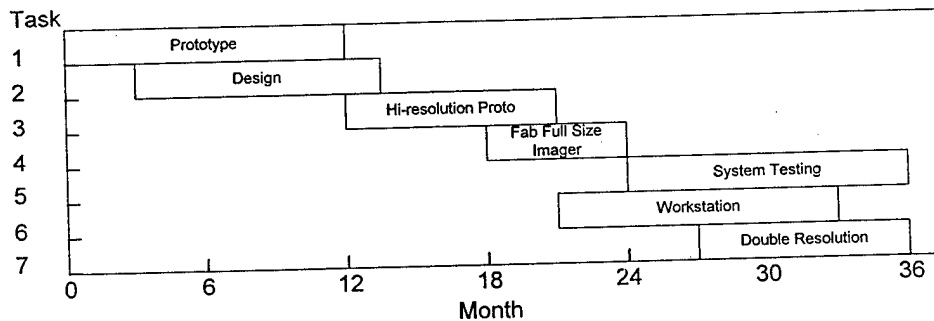

Fig. 17 Three-Year Task Schedule

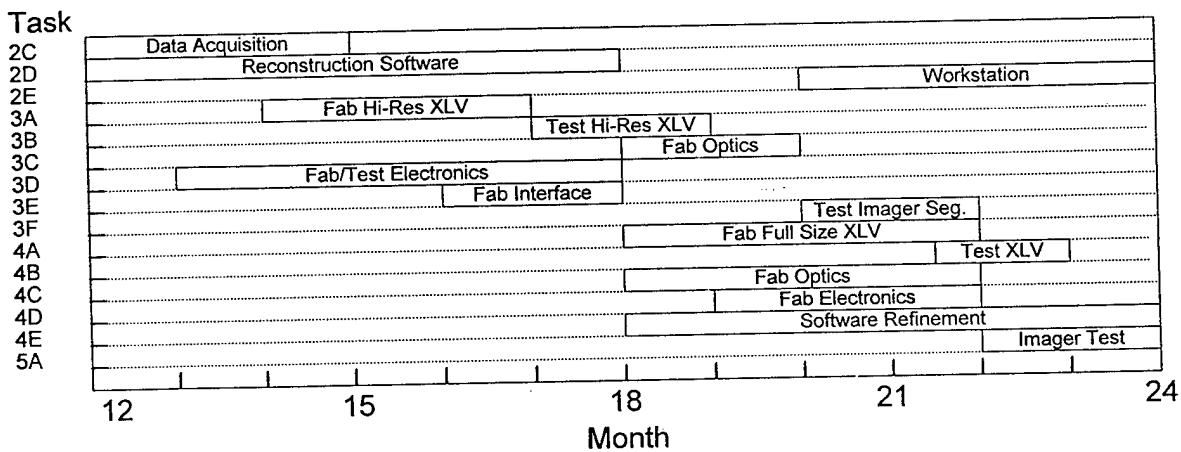

Fig. 18 Detailed Task Schedule for Second Year

## Task Assignments by Investigator

### A. Sensor Plus Inc. (Prime Contractor)

Dr. Darold Wobschall, (Principal Investigator)

Project Manager  
Overall System Design  
Design of Analog Electronics

Vivek Swarnakar  
Software Development Manager  
Reconstruction of Segmented Images

Scott Smith  
Design and testing of DSP hardware and CCD data acquisition

H. Kim  
Design and testing of DSP parallel processor and image transmission system

Myeoung Jeong  
Development of camera connection software, including distortion and alignment

Tom Cordier  
Circuit assembly supervision  
Circuit board layout and EMI reduction

### B. Sunnybrook (U. Toronto)

Dr. John Rowlands  
Supervisor of XLV screen fabrication  
XLV design and testing

P.A.  
Ph.D. student assisting Dr. Rowlands

### C. State University of New York at Buffalo

Dr. Stephen Rudin  
Imager configuration and assuring compatibility with existing x-ray equipment  
Helping with optical design

Dr. Daniel Bednarek  
Associate of Dr. Rudin at Erie County Medical Center. Planning of x-ray testing

William Grainger  
Graduate student assisting Drs. Rudin and Bednarek

D. InfiMed, Inc.  
participated only in a consulting basis during the first year, as planned.

Dr. Thomas Vogelsong (VP)  
Planning of workstation software  
Marketing

E. Consultants

While Litton withdrew from the project during the first year, the following two Litton engineers helped with the XLV design, in effect as unpaid consultants

Dr. Birendra Bahadur  
Consulted on the liquid crystal formulations

Mr. Ronald Ruta  
Assisted in optics design

Dr. Raj Acharya  
Software signal processing and image reconstruction

J. Antonelli  
Designed and fabricated the lens. Provided optical design consultation.

## Statement of Work

This statement is taken from the original proposal.

I. Perform the following tasks described under TASK SCHEDULE in the original proposal:

### Task 1. Build Prototype

Fabricate Small Area X-ray Light Valve  
Test of X-ray Light Valve  
Fabricate Optics  
Electronics Computer, and Interface  
System Test

### Task 2. System Design

XLV  
Optics  
Video Data Acquisition and Interface  
Image Reconstruction Software  
Radiographic Workstation Software  
Adapt to x-ray Unit  
Test Methods and Equipment

### Task 3. Fabricate and Evaluate Small Area, High Resolution Prototype

Fabricate Hi-Resolution X-ray Light Valve (XLV)  
Test of XLV  
Fabricate Optical System  
Design and Test Video Electronics Section  
Fabrication and Test of Workstation Interface  
Test of Imager Segment

### Task 4. Fabricate and Test Full Size Imager

Fabricate Full Size, High Resolution XLV  
Test of XLV  
Fabricate Optical System  
Fabricate Image Acquisition Electronics  
Refinement and Test of Image Processing Software

### Task 5. System Performance Test

Test of Imager

Comparison with Film  
Clinical Trial Planning

Task 6. Preparation, Radiographic Workstation Software

Implementation of Standard Viewing Software  
Verification of Image Quality Robustness  
Environmental Tests  
Image Compression  
Display Tests

Task 7. Implementation and Test of Double Resolution Feature

Fabricate Tilt Plates  
Test with Optical Targets  
System Test

- II. Design and fabricate a mammographic imager and work station with the following characteristics:
- \* 8x10 inch active area (minimum)
  - \* Pixel size approximately 50 microns over full image size and 25 $\mu$ m in restricted areas.
  - \* 12 bit effective dynamic range (gray scale)
  - \* The border on one side of the imager must be under 3mm and preferably 1mm.
  - \* The work station must have the capability to acquire complete radiographs at high resolution (4000 x 5000 pixel minimum, and 8000 x 10,000 preferred). It will display the full image at reduced resolution (relative to the internal resolution), and it will be able to zoom in to view portions of the image at full resolution.
  - \* The basic imager will work with standard mammographic x-ray sources.

### C. References

1. Feuer, E.J., Wun, L.M., Boring, C.C., Flanders, W.D., Timmel, M.J., Tong, T., "The lifetime risk of developing breast cancer," *J. Nat'l. Cancer Inst.*, 1993, June 2;85(11):892-897.
2. Jain, Anil K., *Fundamentals of Image Processing*, Prentice Hall, 1989.
3. Mayer, R., "Direct imaging of x rays with a CCD using hardware processing", *Review of Scientific Instrumentation* 62(2), pp.360-363, February 1991.
4. Karellas, A., Liu, H., Harris, A and D'Orsi, C., "Operational Characteristics and Potential of Scientific-Grade Charge Coupled Devices in x-ray Imaging Applications," *SPIE Vol. 1655* (1992), p. 85.
5. Kutlubay, E., "Real-Time, Light-Weight X-Ray Imager," Yearly report to U.S. Army (May 1995).
6. Lefebvre, F., Gilles, R., Benali, H., Vanel, D. and DiPaolo, R., "Automatic detection of microcalcifications on digitized mammograms", *Scientific Program, 79th Scientific Assembly and Annual Meeting, Radiological Society of North America*, Nov, 1993.
7. Yaffe, M.J., "Digital mammography", *Syllabus: A Categorical Course in Physics Technical Aspects of Breast Imaging, Presented at 78th Scientific Assembly and Annual Meeting, Radiological Society of North America*, Nov, 1992.
8. Freedman, M., et al, "Digital Mammography: Tradeoffs between 50 and 100 Micron Pixel Size," 1995 *SPIE Medical Imaging Conference*, paper 2432-09.
9. Kutlubay, M., R. Wasserman, D. Wobschall, R. Acharya, S. Rudin, and D. Bednarek, "Cost Effective, High-Resolution, Portable Digital X-ray Imager," *SPIE Vol. 2432*, (p 554), (San Diego, Feb. 1995).
10. Henry, J.M., Yaffe, M.J., Pi, B., Venzon, J., Augustine, F., and Tumar, T.O., "Solid state x-ray detectors for digital mammography," *Medical Imaging 1995: Physics of Medical Imaging*, Ed. R.I. Van Metter and J. Beutel, *Proc. SPIE 2432*, 392-401 (1995).
11. Que, W., and Rowlands, J.A., "X-ray imaging using amorphous selenium: Inherent spatial resolution," *Med. Phys.* 22, 365-374 (1995).
12. Zhao, W., and Rowlands, J.A., "Digital radiology using self-scanned readout of amorphous selenium," *Medical Imaging 1993: Physics of Medical Imaging* Ed. by: R. Shaw, *Proc. SPIE 1896*, 114-120 (1993).
13. Zhao, W., and Rowlands, J.A., "X-ray imaging using amorphous selenium:

Feasibility of a flat panel self-scanned detector for digital radiology." *Med. Phys.* (in press).

14. Schaffert, R.M., *Electrophotography*, (Focal Press, London, 1980), p. 284.
15. Fahrig, R., Rowlands, J.W. and Yaffe, M.J., "X-ray imaging using amorphous selenium: Detective quantum efficiency of photoconductive image receptors for digital mammography, *Med. Phys.* 22, 153-160 (1995).
16. Fahrig, R., Rowlands, J.A. and Yaffe, M.J., "X-ray imaging using amorphous selenium: Optimal spectra for digital mammography, *Med. Phys.* (submitted)
17. Rieppo, P.M. and Rowlands, J.A., "Amorphous selenium liquid crystal light valve for x-ray imaging," *Medical Imaging 1995: Physics of Medical Imaging*, Ed. R.L. Van Metter and J. Beutel, Proc. SPIE 2432, 228-236, (1995).
18. S. Hejazi and D. Trauernicht, "Potential Image Quality in Scintillator CCD-based x-ray imaging system for Digital Radiography and Digital Mammography, *SPIE Vol. ( ) Newport Beach, 1996.*

## Appendix A Description of Imager

The sections of the imager which have been started in the first year expected to be finished in the second year are described here.

### 1. Multi-segment X-ray Optics and Electronics

Very high internal image resolution is achieved with a moderate quality optical system and moderate resolution CCDs by combining subsection images from an array of CCDs. The advantages of this method were demonstrated previously.

The optical system converts the single, large image produced on the XLV screen into separated images on the CCDs. The Kodak KAF0400 512x768 pixel which has CCD image area of 5.5x8.4mm (9  $\mu$ m pixels) has been selected. The array will be 8 by 9 (72 elements) and each segment is 24x36 mm. The readout electronics scans the CCD array, converts the analog pixel information to digital signals and transfer this data to a computer for processing. Since the fast (2 MHz) 12-bit a/d is preceded by a software controlled biasing procedure, the digital pixel information will have a minimum effective 12 to 13-bit dynamic range. Data transfer time is about 0.16 sec per CCD (about 20% of standard video rate). The CCDs are read out in parallel ( data conversion channels), since the subsection imaging method allows reading (capturing) the subimages in parallel.

The necessary timing signals for the CCDs and the control signals for the overall readout electronics will be produced by a high speed digital signal processing unit (TI320). Data will be stored in a local dynamic RAM (32 Mbyte for each DSP).

During the CCD image readout cycle, the digital signal processing units (DSP) will control the process. After the CCD readout cycle is completed, each (of 18) DSP will be used to pre-process the segment images. Since the DSP unit supports the arithmetic operations necessary for image processing techniques it will do all the required image processing before data transfer. A Pentium PC will display the final, full image. The DSP is able to scale each pixel individually and do other image pre-processing functions. There is one DSP for each 4 CCDs.

Although illumination by the LEDs and is not uniform over the XLV panel, the non-uniformity is corrected by the individual CCD pixel normalization.

### 2. Selenium/Liquid-Crystal X-ray Light Valve Image Intensifier

An improved version of the x-ray light valve (XLV) originally developed by Sunnybrook/Univ. of Toronto and Litton/Canada will be used for this imager. The main improvements are larger screen size (8.5" x 11.5"), somewhat better resolution (10 to 25  $\mu$ m), and side illumination.

The main development effort for the XLV is the production of the large amorphorous selenium layer, which has been done, and the corresponding liquid crystal layer which has not (July 1997). Both must be uniform over the image area.

### 3. Image Data Acquisition Sequence

The acquisition sequence, controlled by the DSP, is as follows:

- X-ray Detection: The x-ray sensor detects the presence of x-rays and estimates the exposure.
- Preliminary Scan: The bias light is turned on for the time needed to shift the response curve just above threshold. The CCDs are scanned at maximum rates and sample intensity measured.
- Scans at Second Exposure Level (optional): After blue light produces a further shift in the response curve to obtain data at a different exposure level. At this point the image has been acquired.
- Pixel Response Normalization: Each pixel response is corrected by a set of previously determined calibration factors. Also missing pixels are filled in by interpolation. This step will take 2-4 sec (since calibration data has been pre-loaded into the respective DSP memory).
- Image Reconstruction: The reconstruction PC will take 1 to 5 seconds.
- Data Transfer to PC: The data transfer will be done concurrently with the alignment (after the first set of CCDs) and will finish about 2 sec. after the alignment is done. The total time from x-ray exposure to image on a video monitor screen will be 12 to 30 seconds.

### 4. Image Processing

The image data supplied by the sensor itself will be processed by the local DSP's included with the sensor array to provide an image as described in the Image Data Acquisition Sequences section above. This includes acquisition of the 12 bit pixel values, camera or distortion/misalignment correction, intensity normalization, and stitching of the segments of the image to form the complete image. Later dynamic range enhancement through a second scan at different bias light conditions, multi-frame averaging, and resolution enhancement by acquiring additional images at half-pixel shifted values will be done. Thus the composite images transferred to the workstation will provide 12 bit pixel values with resolution nominally at 4000 x 5000 pixels but potentially as high as 8,000 x 10,000 pixels.

Appendix B. Detailed Circuit Diagrams (confidential)