

ARMY GROUND RISK-MANAGEMENT PUBLICATION COUNTERMEASURE

VOL 18 NO 12

<http://safety.army.mil>

DECEMBER 1997



19971211 048

ROLLOVER! ROLLOVER! What can you do?

Over the past ten(10) years there have been 176 Army Combat Vehicle (ACV) accidents involving a rollover or turnover. Of these 176 accidents, 55 resulted in a fatality. Over 33% of the accident victims *did not survive*. The number of accidents and the number of fatalities are too high. What can we do about it? Can we make improvements in our efforts to reduce the number of rollover/turnover accidents, and also improve our chances of surviving such an accident?

Several Bradley fighting vehicles(BFV) were conducting a recon mission, in the desert(low contrast area), on an extremely dark night(low illumination). The platoon was expecting enemy fire, so they were maneuvering with blackout drive lights. They had not trained sufficiently under blackout conditions. The drivers were using AN/VVS2 Driver's Night Sights. The Bradley Commanders were using

AN/VVS7 Night Vision Goggles(NVGs) and Global Positioning Systems for navigation. As they approached their objective, three BFVs traveling abreast went over one small ditch and immediately came upon what appeared to be another ditch. However, rather than a small ditch, it turned out to be a 15-foot cliff. All three BFVs went over the cliff and tumbled into the wadi below. Two soldiers were killed and eight others injured.

What caused it?

The unit had not fully incorporated risk management into their mission planning for this operation. They had not trained using NVGs and NVDs under total blackout conditions prior to this mission. They failed to identify and develop controls for a critical hazard: operating over rough terrain at night, under total blackout conditions.

DISTRIBUTION STATEMENT A

Approved for public release;
Distribution Unlimited

DTIC QUALITY INSPECTED 2

What to do about it

To prevent accidents from the same or similar causes, unit leaders should consider the following controls:

- Assess risks realistically and plan controls to reduce the hazards;
- Train vehicle crews on dark adaptation and night vision techniques, ground guiding at night, sensory illusions at night, and the capabilities and limitations of night vision devices;
- Ensure that primary and alternate drivers are fully trained and qualified to operate their vehicles day and night;
- Ensure that night vision devices have been properly serviced and are in good working order;
- Emphasize the terrain hazards and the impact of low light levels on the equipment and personnel. Stress the dangers of overconfidence in either equipment or personnel ability to operate under adverse condition;
- Use ground guides when visibility is restricted;
- Enforce the requirement for crew members to use installed restraint systems;
- Establish and rehearse crew drills, rollover/turnover procedures designed for your particular type vehicle;
- Enforce the standards that requires vehicle commander(TC) and crew members, to position themselves at name-tag level while operating in the open hatch position;

What happened?

A convoy departed the unit motor pool at approximately 0530. The convoy proceeded uneventfully except that one Vehicle Commander instructed his driver several times to keep the vehicle in the center of the road. No problems were noted with the M981A2. At approximately 0555, with the convoy traveling south on a tank trail at approximately 20 mph, the TC instructed his driver to slow down prior to descending a hill they were approaching. When the driver did not respond, the TC repeated his instructions several times, but the driver still did not respond.

As the M981A2 began to go down the 7-degree slope, it veered to the right and then back to the left several times. Each time the vehicle veered, the driver "overcorrected" in the opposite direction. The vehicle continued to swerve left and right, and at approximately 0556, the vehicle hit an embankment on the left side of the tank trail at approximately a 60-degree approach angle. As the left track of the M981A2 began to climb the embankment, the TC ducked into the vehicle in anticipation of the vehicle rolling over and transmitted over the radio, Rollover! Rollover! Rollover!" He gave no other instructions to the driver. The vehicle rolled to the right, down the slope, and came to rest on its top, fatally injuring the driver.

What caused it?

This company had an excellent written driver's

Mission:

Night recon to establish contact with the enemy

Results:

2 fatalities and 8 injuries

Contributing Factors:

Did not fully incorporate risk management into their mission planning for this operation.

Had not trained using NVGs and NVDs under total blackout conditions prior to this mission.

Failed to identify and develop controls for a critical hazard: operating over rough terrain at night, under total blackout conditions.

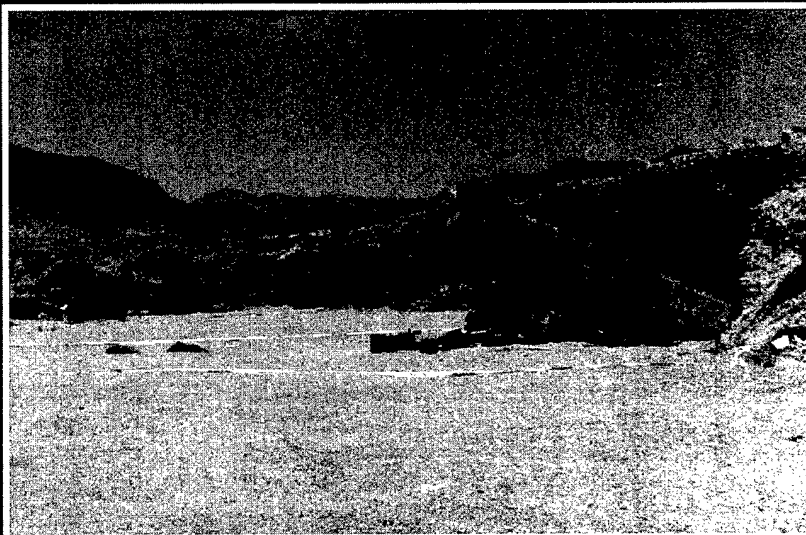

training program. However, they failed to follow it. The commander did not conduct an interview of the prospective driver, did not ensure the eye examination was performed, and signed the learner's permit despite the discrepancies pointed out by the assistant master driver. Inadequate or negligent driver's training and licensing programs and inadequate commander involvement allowed a soldier with:

- 20/70 vision
- Without a civilian driver's license
- With little to no experience driving any type of vehicle, including a POV
- Without proper or adequate driver's training
- With no experience operating the vehicle outside the motor pool area

This soldier was issued a learners permit and allowed to operate a track vehicle within a convoy.

What to do about it

- A properly conducted interview, coupled with risk assessment, would have identified the soldier as a high risk individual. Once identified as a high risk driver, the commander should have implemented additional control measures to reduce or eliminate the associated risk;
- Commanders have a responsibility to ensure the operator has received the required training and meets appropriate qualifications;
- The Commander's interview is an integral part of the aspect of managing risks and must be taken seriously;
- Review driver's training and licensing program, ensure that it does not allow unqualified or untrained personnel to receive operator's permit or licenses;
- Commanders are charged with developing and publishing guidance for establishing and implementing risk-management programs that identify potential hazards, determine the associate risk,

and implement controls in an effort to mitigate the inherent risk;

- Establish and rehearse crew drills, rollover and turnover drills and procedures;

What happened

Two soldiers operating an M3A2 Cavalry Fighting Vehicle (CFV) encountered catastrophe while enroute from a Unit Maintenance Collection Point (UMCP) back to their troop assembly area. The gunner acting as the Bradley Commander (BC) and the assigned driver were escorted from the UMCP by a HMMWV at approximately 2000 hours. The BC used the AN/PVS 7-B Night Vision Goggles(NVG) and the driver was using the AN/VVS-2 Driver's Night Vision Viewer(DNVV). Visibility was limited by the near-zero illumination that night. The blackout drive headlights were not used to



Mission:

Reposition vehicles from Ft. Carson Camp Red Devil in preparation for squadron live fire exercise.

Hazards:

- Inadequate drivers training
- Improper supervision
- Convoy operations
- No rollover training program
- Vehicle inspection program not enforced

Summary: While traveling as the second of three vehicles in a tactical convoy, the driver lost control while descending a 7 degree slope, turned into an embankment to the left of the tank trail, and the vehicle flipped over onto its top resulting in one fatality, 3 minor injuries, and minor vehicle damage.

assist in movement because it was not consistent with unit SOP. As the two vehicles turned off onto a tank trail, the HMMWV encountered a mud hole. The NCOIC decided to return to the MSR and wait until daylight to continue. As he drove past the CFV, he shouted (in the dark, over the engine noise of both vehicles and through the CVC helmet) for the BC to turn around and follow him to the MSR. The CFV, operated by two Specialists, continued on by itself to the Assembly Area. When they arrived at the Assembly Area the Troop was no longer there. The BC called the Platoon Leader (PLT LDR) for new instructions. The PLT LDR told him to go to the Troop Operations Center (TOC). He also warned him of an arroyo that was near the TOC location. The BC did not have a map so he could not determine the exact location of the hazard in relation to his path to the TOC. The

BC radioed the TOC OIC for grid coordinates. The OIC suggested to the BC that "his best bet was to go to ground" due to the visibility and the arroyo to the north of the TOC. The BC continued towards the TOC aided by the NVGs and the DNVV. One hour later the CFV drove over a 14-foot cliff (arroyo) landing on its turret and killing the BC.

What caused it

The unit maintenance sergeant leading the Bradley CFV cross-country at night did not confirm the BC fully understood his directives for the BC to turn around and follow him back to the main supply route. As a result, the BC continued cross-country with his Bradley. The BC continued moving cross-country with his vehicle without a guide in near-zero illumination, and with night vision systems that

do not provide optimum visual acuity for definition and depth perception, even after being advised that an arroyo was near "the TOC" his destination. At the time of the accident the BC was not seated and secured in his seat by a seatbelt.

What can we do about it

- Ensure that leaders understand the need for positive communications and that all leaders are responsible for ensuring that their directives are understood;
- Ensure that all personnel understand how overconfidence and improper motivation can influence action

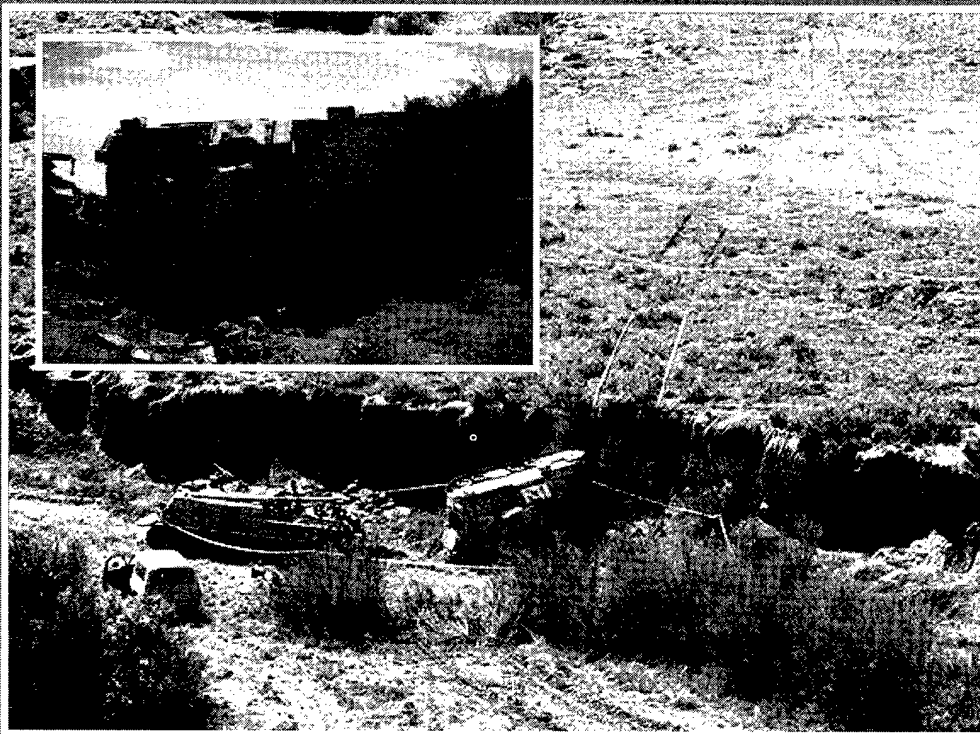

MISSION: M3A2 movement from unit maintenance collection point to assembly area.

RESULT: 1 soldier fatally wounded when vehicle rolled over.

CONTRIBUTING FACTORS:

- Inexperienced BC
- Cross country movement without map
- Use of AN/VVS-2 without supplemental illumination
- Lack of positive communications

and contribute to accidents;

- Establish and enforce a Vehicle Commander selection process to ensure only qualified personnel are tasked to function as a TC or BC;

- Enforce the seatbelt requirement IAW AR 385-55;

- Ensure that vehicle commanders are not riding too high and maintain name-tag level position while operating in the open-hatch position;

- Establish and rehearse crew drills, rollover/turnover drills and procedures;

Rollovers/Turnovers don't have to kill

Recent accidents involving rollover/turnover have spurred inquiries from units in the field. They are requesting rollover drills that crews can use in the case of a rollover accident. Some units are conducting training on rollover procedures and how crews should react to a rollover sequence. Rollover drills are a vital training necessity but by themselves will not reduce the number of accidents nor reduce the number of fatalities. Commander's must use the drills as only part of an aggressive Risk management program. There are other control measures which must be implemented to reduce the risk.

1. Train vehicle crews on dark adaptation and night vision techniques, ground guiding at night, sensory illusion at night, and the capabilities and limitations of night vision devices.
2. Identify the terrain hazards and how low light levels impact on them.
3. Stress the dangers of overconfidence in either the equipment or personal ability to operate under adverse conditions.
4. Ensure that night vision devices have been properly serviced and are in good working order.
5. Ensure that primary and alternate drivers are fully trained, qualified and properly licensed to operate their vehicles day and night.
6. Enforce the requirement for crew members to use installed restraint systems.
7. Enforce the standards that requires vehicle commanders and crew members to position themselves at name-tag level during open hatch operations.
8. Establish and rehearse crew drills regularly; such as fire evacuation, loss of brakes, loss of steering, loss of power and **rollovers**.
9. Assess the risks realistically and plan controls to reduce the hazards.

Many of us, do agree that crews should be so well trained that their response to a rollover/turnover situation or accident is automatic.

Many of the vehicle Technical Manuals(TM) give some guidance or information on "Rollover/Turnover Drills". In the TMs, that we have reviewed, vehicle rollover/turnovers appears as a warning or caution statement.

For Example: Warning

When a track vehicle gets out of control and overturns, it is safer to stay in the vehicle than to try to get out while the vehicle is still moving. You may receive slight injuries from being thrown against metal parts; but if you try to leave the vehicle, it may roll over and crush you. Once the vehicle stops moving, get out as fast as possible because spilled fuel and oil may catch fire. The first thing the driver should do in such an emergency is shut off the engine and turn off the master switch to minimize the fire hazard. Ref--TM 9-2350-266-10. (M981)

In some cases only a general warning statement and picture. Ref-- TM 9-2350-261-10 (M113A2)

WARNING

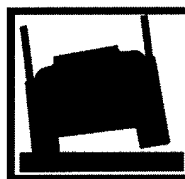

Carrier can roll over and kill or injure personnel. Avoid high speeds and sudden turns when driving on

hills or rough terrain. Wear seat belts.

The best example; for guidance information that we have reviewed, exists inside the M1A1/M1A2 TM 9-2350-2264-10-2/TM 9-2350-288-10-2. See examples of emergency procedures on pages 6-9.

Many recommendations have been made to incorporate procedures with specific instructions of what actions crewmen should take in the event of a rollover in all Army Combat Vehicle Technical Manuals(-10). Some suggest that "Rollover/Turnover Drills" or Rollover Procedures should be incorporated into training ..i.e., Driver's Training Courses and TRADOC formal training courses. It has been recommended that all ACV crewmen regularly practice emergency action drills for accidents such as fires, loss of brakes, loss of steering, loss of power and "rollovers". It is not safe to say that "rollover drills" alone will eliminate the possibilities of a rollover/turnover accident being fatal. But it is safe to say that a reaction to a hazardous situation is far better than no action at all. ♦

POC: SFC Erwin Bailey, AR, Combat Arms Systems, Ground Tactical Branch; DSN 558-2908 (334-255-2908)

EMERGENCY PROCEDURES

TM 9-2350-288-10-2

ROLLOVER (TOP)

WARNING

- At first indication of a rollover, drop down inside turret and brace for impact. Exposed personnel could be thrown from tank, causing injury or death. Do not attempt evacuation from unstable tank. Evacuate with caution when tank has stabilized.
- Ensure all hatches are in open-lock position, if possible, before evacuating. An unlocked open hatch can fall, causing injury or death.
- Each crewmember must ensure all loose items and equipment are firmly secured prior to tank movement. Loose items and equipment can cause severe injury or death.

CAUTION

Do not turn MASTER POWER off before ENGINE SHUTOFF pushbutton is pressed for off. Engine damage or fire could occur.

NOTE

Each crewmember task is performed at the same time as other crewmember tasks.

TANK COMMANDER

A. Once tank has stabilized, survey situation and check crewmembers for injuries. Administer first aid if critical situation exists (see FM 21-11).

B. If turret fire exits, use commander's portable fire extinguisher (1) to fight fire (see 2-154).

C. Check for evacuation route. Evacuation route should be through whatever hatch (driver's (2), loader's (3), or tank commander's (4)) can be most easily opened. Announce EVACUATE once route is established

WARNING

Turret lock must be locked if crewmembers pass between hull and turret during evacuation. Turret/hull could move, causing injury or death to crewmembers.

D. If evacuation cannot be accomplished and life threatening situation does not exist, radio for rescue and turn off vehicle master power or direct driver to turn off vehicle master power. Direct crewmember to wait for rescue personnel, and administer first aid if necessary (FM 21-11).

E. If life threatening situation exist for any turret crewmember or driver, instruct gunner to attempt traversing hull to allow access to driver's station. Evacuate through established route once tank has fully stabilized.

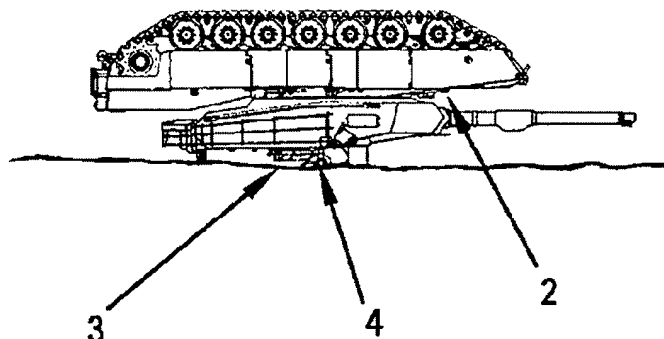
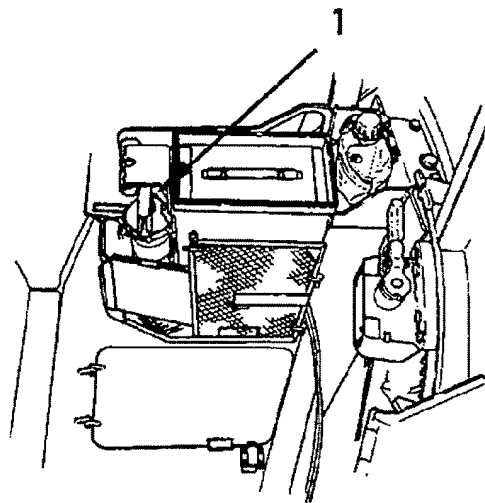

2-891

EMERGENCY PROCEDURES

ROLLOVER (TOP) - Continued

F. If evacuation is accomplished, direct crewmembers to assemble 98 feet (30 m) to rear of tank. Administer first aid if necessary (see FM 21-11).

GUNNER

A. Ensure tank has stabilized and set GUN SELECT switch (5) to TRIGGER SAFE.

WARNING

Turret lock must be locked if crewmembers pass between hull and turret during evacuation. Turret/hull could move, causing injury or death to crewmembers.

NOTE

One or more turret screens may have to be removed to allow evacuation of turret crewmembers through driver's hatch (2), or driver through turret.

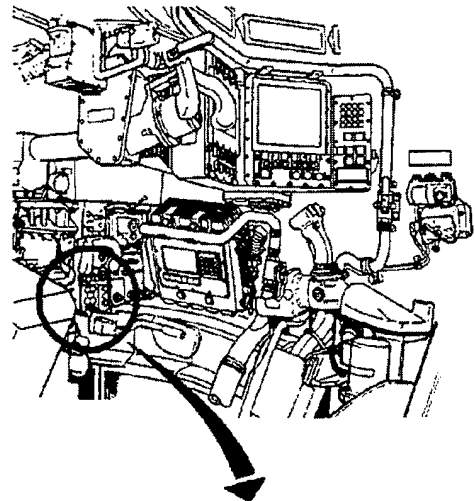

B. Check turret for obstructions. On tank commander's order, attempt to traverse hull (with power or manually) so turret crewmembers can evacuate through driver's hatch (2), if necessary, or driver can evacuate through turret, if necessary. Direct loader to set turret lock if access is achieved.

C. On tank commander's order, evacuate tank, if possible, by established route once tank has fully stabilized. If no evacuation route exists, remain in turret and wait for rescue personnel.

D. If evacuation is accomplished, report to assembly area 98 feet (30 m) to rear of tank.

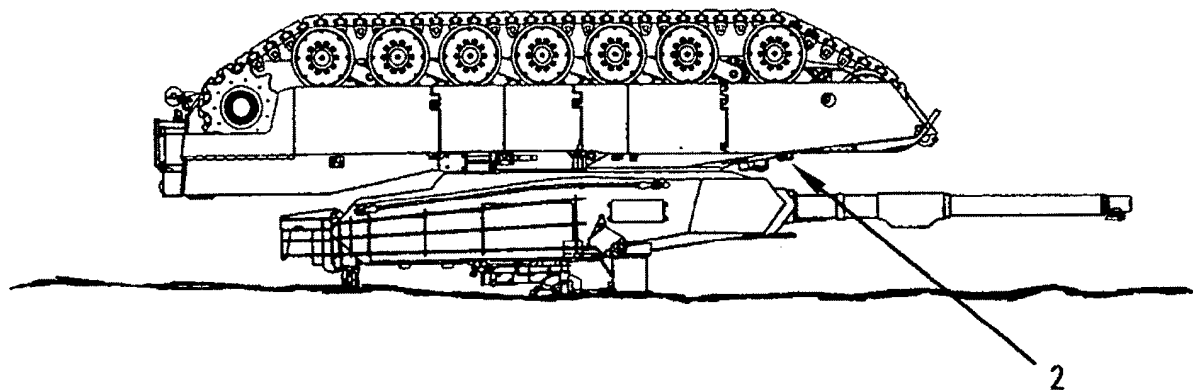
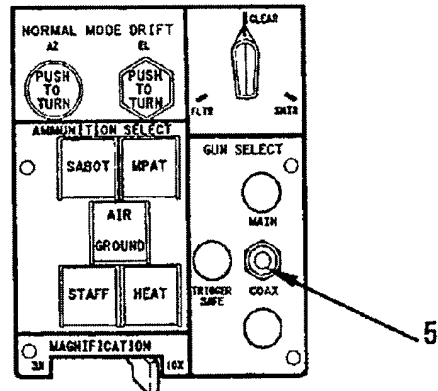

EMERGENCY PROCEDURES

TM 9-2350-288-10-2

ROLLOVER (TOP) - Continued

LOADER

- A. Once tank has stabilized, establish contact with driver.
- B. Move SAFE/ARMED handle (6) down to SAFE position.
- C. Make sure MAIN GUN STATUS SAFE light (7) is lit.
- D. Assist gunner in checking turret for obstructions, as required, and set turret lock (8) on gunner's order.
- E. Assist turret crewmembers with evacuation through driver's hatch (2), if necessary. Assist driver with evacuation through turret, if necessary.
- F. On tank commander's order, evacuate tank, if possible, through established route. If no evacuation route exists, remain in turret and wait for rescue personnel.
- G. If evacuation is accomplished, report to assembly area 98 feet (30 m) to rear of tank.

DRIVER

- A. Once tank has stabilized, announce SHUT DOWN and shut down engine (see 2-216).
- B. If engine fire exists and the 1st shot (automatic) bottle has not extinguished the fire, activate 2nd shot fire extinguisher switch (9).

NOTE

If main gun positioned anywhere except center, 45° right from center, or 45° left from center, driver can evacuate through driver's hatch (2) without removing driver's night vision viewer, if installed.

- C. On tank commander's order, press MASTER POWER pushbutton (10) for off. Remove driver's night vision viewer, if installed (see 2-216).

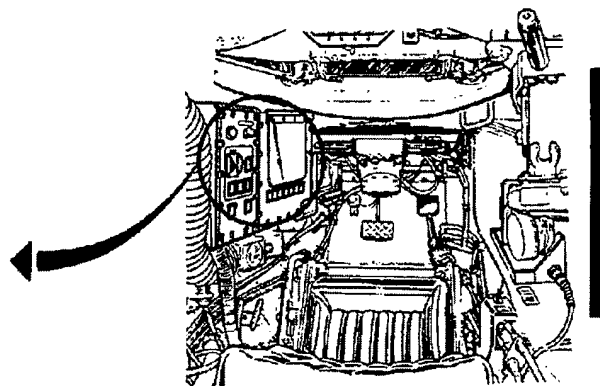
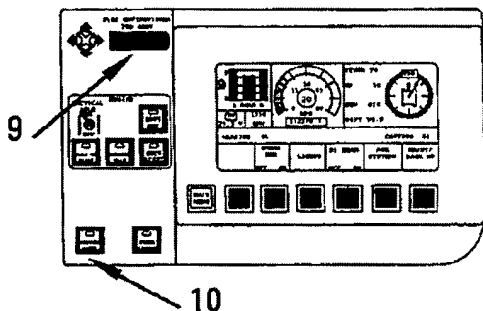
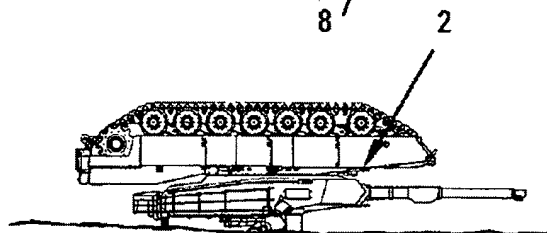
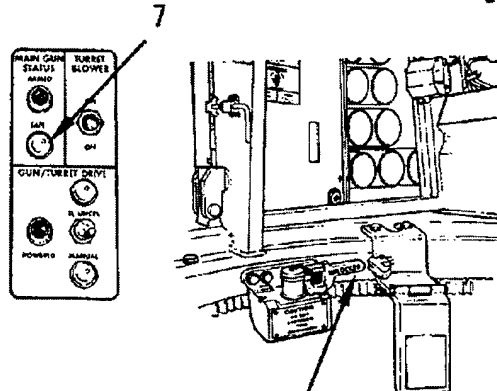
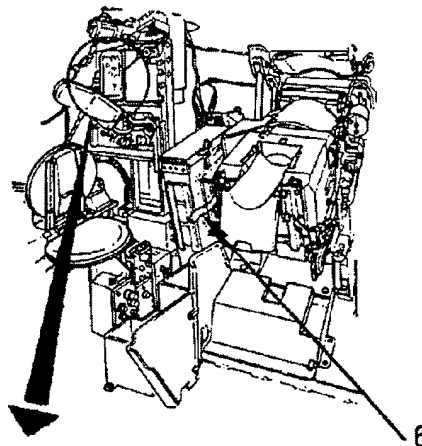

Change 4

2-893

EMERGENCY PROCEDURES

ROLLOVER (TOP) - Continued

WARNING

Driver must not evacuate until turret is locked and command **DRIVER EVACUATE** is given. A traversing turret could cause injury or death.

NOTE

One or more turret screens may have to be removed to allow either evacuation of turret crewmembers through driver's hatch (2), or driver through turret.

D. Once vehicle has stabilized, announce **DRIVER EVACUATION** and evacuate, on tank commander's order, through driver's hatch (2) if possible. If not possible, crawl through to turret once route is cleared and turret lock is locked. Evacuate through established route once tank has fully stabilized.

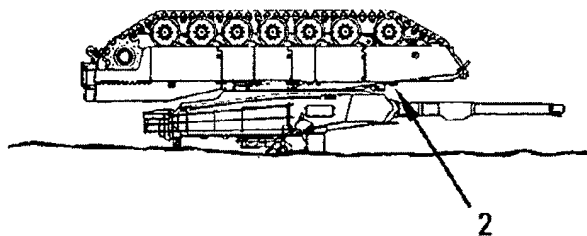

E. Report to assembly area 98 feet (30 m) to rear of tank.

WARNING

Upon complete evacuation of all crewmembers, tank should be inspected for fire hazards such as leaking oil, fuel, hydraulic fluid, and electrolyte. Stand by with portable fire extinguisher when inspecting tank for leaks in case of fire, which could cause injury or death.

2-894

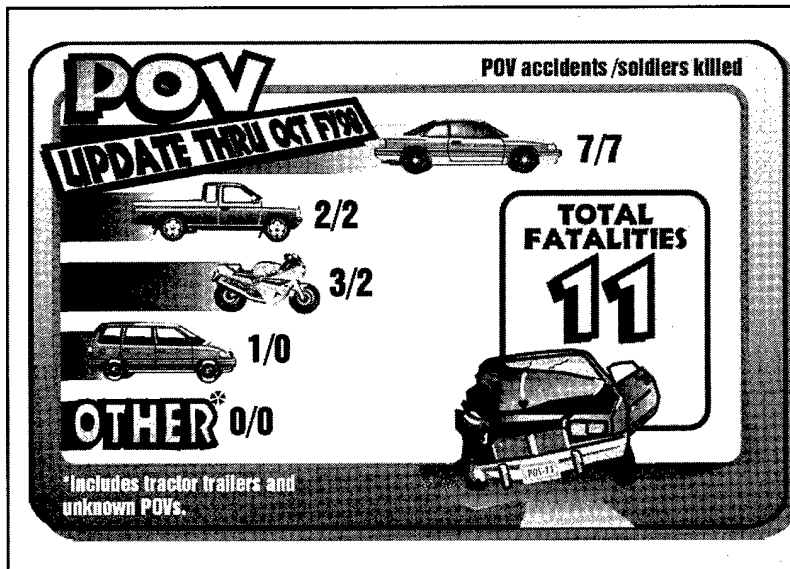

Report of Army ground accidents; published by the U.S. Army Safety Center, Fort Rucker, AL 36362-5363. Information is for accident prevention purposes only. Specifically prohibited for use for punitive purposes or matters of liability, litigation, or competition. Address questions about content to DSN 558-2688 (334-255-2688). Address questions about distribution to DSN 558-2062 (334-255-2062).

Burt S. Tackaberry
Brigadier General, USA
Commanding

CY 97 Countermeasure index

Automation

Risk-management information - *March*
USASC information systems structure - *March*
USASC information strategy - *March*
Oops, we goofed - *March*
ARAC is on the Web - *May*
Arsenal's forge earns award - *November*

Awards

Sergeant awarded Soldier's Medal for rescue - *June*
PFC Watson and SPC Hill receive the Army's Safety Guardian Award - *June*
Safety Guardian Award facts - *June*
North Dakota Guardsmen awarded for Heroism - *August*

Batteries

Battery explosion injures soldier - *February*
PLGR memory battery installation - *June*

Biological hazard

Another accident-site hazard - *February*

Chemicals

Advanced composite materials - *February*
CO2 fire extinguishers in Army weapon systems - *April*

Cold Weather

Cold-Weather injuries (poster) - *November*

Driver Certification

Applying risk management in the field - *May*
The road ahead - *July*
Inadequate driver selection equals mission failure - *July*
Who needs a commercial Drivers' License (CDL)? - *July*

Explosives

Helping soldiers recognize UXO - *February*
Live demolition training fatality - *February*

Family safety

Moving-There's something you need to know - *February*
Lead in miniblinds - *February*
Lead (Pb) exposure control guide - *February*
Home smoke alarms - *February*
Guess what, honey, we're going to Hawaii - *June*
How to prevent foodborne illness - *June*

The home heating unit - *November*
The identity of a hazard - *November*

Field Artillery

NCO business - *July*

Fire safety

Close call in Bosnia - *February*
CO2 fire extinguishers in Army weapon systems - *April*
Gas cans and plastic bedliners don't mix - *July*
What you need to know if your car catches fire - *September*
The home heating unit - *November*

From the field

It just keeps going and going... - *February*
Split-rim wheel safety training - *March*

Health

Smoking can get you now and later - *March*
Smokeless can be hazardous - *March*
Sports injuries - *March*
Heat-number one summer health hazard - *April*
How the body handles heat - *April*
Sunburn: A painful experience - *April*
Only tennis players get tennis elbow...right? - *June*

Hot weather

Heat-number one summer health hazard - *April*
How the body handles heat - *April*
Managing heat stress in NBC operations - *April*
Sunburn: A painful experience - *April*
Guess what, honey, we're going to Hawaii - *June*
Summer fun or needless tragedy? - *June*
Beware of ticks! - *July*
Heat injury: Plenty of fluids essential to heat injury prevention - *August*
Guideline for water requirements - *August*

Hunting

Tis the season to be... "Hunting" - *October*

Kevlar

Understanding your ballistic helmet...Sized to provide comfort and protection? - *October*

Laser pointers

Hazard alert for tactical laser pointers - *October*

NBC operations

Managing heat stress in NBC operations - *April*

Night Vision Goggles (NVG)

BC dies in night operation accident - *October*
Night convoys - *October*

Nomex

The right gear for the job - *August*
It's hazardous to wear synthetic fiber underwear under a Nomex suit - *August*

Parachute operations

Night jump turns tragic - *January*

POVs

A different kind of war - *May*
Share the success - *May*
ARAC is on the Web - *May*
Stayin' alive - *May*
You Booze, You Lose (poster) - *May*
On-duty, Off-duty; risk management a continuous process - *May*
Never argue with a big truck - *May*
Talking and drinking don't mix - *May*
The road ahead, DASAF - *July*
A seatbelt takes away my right... to DIE! - *July*
Safe driving tips - *July*
Defend yourself - *August*
What you need to know if your car catches fire - *September*
Aggressive drivers? - *October*
Are you ready for winter? - *November*
Holidays-happiness and celebration - *November*

Posters

You Booze, You Lose poster - *May*
On-duty, Off-duty; risk management a continuous process - *May*
Safe distances to maintain when driving AMVs at 40 and 50 miles per hour - *September*
Ingredients for a successful mission - *November*
Cold-Weather injuries - *November*
Risk management - Force protection
The challenges of change, DASAF - *January*
Risk management information - *March*
Risk management could have made a difference - *April*
On-duty, Off-duty; risk management a continuous process - *May*
Applying risk management in the field - *May*
The road ahead, DASAF - *July*
Managing risk-An example of mission success - *August*
Risk management pointer - *September*
Ingredients for a successful mission (poster) - *November*
Safety messages
Recap of SOUMs, GPMs, and MAMs for 4th Quarter FY 96 - *January*

Additional SOUMs and GPMs for 4th Quarter FY 96 - *February*
SOUMs and MAMs for 1st Quarter FY 97 - *March*
GPMs for 1st Quarter FY 97 - *April*
GPMs and MAMs for 3rd Quarter FY 97 - *September*
Maintenance Advisory Message for the M16A2 rifle - *October*

Tracked vehicles

Driver killed when M981 FISTV flips - *January*
Risk management could have made a difference - *April*
CO2 fire extinguishers in Army weapon systems - *April*
Vehicle safety profile: BSFV-E upgrade - *June*
Inadequate driver selection equals mission failure - *July*
Army vehicle analysis - *July*
The right gear for the right job - *August*
Do not override BFV driver's hatch safety latch! - *August*
Night convoys - *October*
Rollover! Rollover!: What can you do? - *December*
Traveling down the risk-management highway
Applying risk management in the field - *May*
Safety: A return to basics - *August*
Force protection can be risky business - *September*

Water safety

Summer fun or needless tragedy? - *June*
Guess what, honey, we're going to Hawaii - *June*
Life jackets-They float. You don't - *June*
Managing risk-An example of mission success - *August*

Wheeled vehicles

M989A1 HEMAT trailer accident claims life - *January*
Tire cages - *March*
Split-rim wheel safety training - *March*
Who needs a Commercial Drivers' License (CDL)? - *July*
Army vehicle analysis - *July*
Convoys - *September*
Risk management pointer - *September*
NCO's enforce standards - *September*
Preparation of drivers - *September*
Safe distances to maintain when driving AMVs at 40 and 50 miles per hour - *September*
Convoy checklist - *September*
Questions and answers on Commercial Drivers Licenses (CDL) - *October*

Reporting accidents: Doin' it right

Even though it's been well over a year since accident-reporting procedures changed, many units are still doing it the old way — which is now the *wrong* way.

Briefly, DA Form 285-AB-R (Abbreviated Ground Accident Report) is now used to report all off-duty accidents and all Class C and D on-duty ground accidents. DA Form 285 (U.S. Army Accident Report) is used only for reporting Class

A and B on-duty ground accidents.

Army accident reporting requirements are outlined in AR 385-40: *Accident Reporting and Records*, and they are **mandatory**. Details on completing all accident-reporting forms, along with reproducible forms, are in DA Pam 385-40: *Army Accident Investigation and Reporting*. ♦

POC: Mr. Dave Brown, Support Directorate, DSN 558-2001, commercial (334-255-2001)

U.S. ARMY ACCIDENT REPORT			FOR USASC USE ONLY	
For use of this form, see AR 385-40; the proponent agency is OCSA.				
SECTION A - ACCIDENT INFORMATION				
1. CHECK ONE <input type="checkbox"/> a. INITIAL <input type="checkbox"/> b. CHANGE		2. UIC (Unit Identification Code) (6-Digit Code of Unit Having Accident)		3a. UNIT NAME AND MILITARY
4. DATE OF ACCIDENT a. YR. b. MO. c. DAY		5. TIME OF ACCIDENT (Local Military Time)	6. PERIOD OF DAY (Check one) <input type="checkbox"/> a. Day <input type="checkbox"/> b. Night	7. ACCIDENT OCCURRED (Check one) <input type="checkbox"/> a. On Post <input type="checkbox"/> b. Off Post
10. WERE EXPLOSIVES OR AMMUNITION INVOLVED OR PRESENT? <input type="checkbox"/> YES (See instruction book) <input type="checkbox"/> NO		11. EXACT LOCATION OF ACCIDENT (Detailed enough to locate site) (State type of location)		
12. NAME (Last, First, MI)				
13. SOCIAL SECURITY NUMBER (SSN)		14. AGE		
15. SEX (Check) <input type="checkbox"/> a. Male <input type="checkbox"/> b. Female	16. RANK OR GRADE	17. MOS OR JOB SERIES		
18. ADDRESS (Use Official Address for All Military or Government Personnel) (If different than block 3, add UIC.)				
19. DUTY STATUS AT TIME OF ACCIDENT (Check one) <input type="checkbox"/> a. On Duty <input type="checkbox"/> b. Off Duty		20. FLIGHT STATUS (Check one) <input type="checkbox"/> a. YES <input type="checkbox"/> b. NO		
21. CONTINUOUS DUTY (hrs) (Without sleep)		22. HRS. SLEEP IN LAST 24 (Without sleep)		
23. DAYS LOST (Est. no. of days lost from work; not counting day of injury. Bed rest/on quarters.)		24. DAYS HOSPITALIZED (Est. no. of days hospitalized receiving treatment, not for observation only.)		
25. DAYS OF RESTRICTED WORK ACTIVITY (Est. number of days person cannot perform regular duties; light duty/profile.)				
26. SEVERITY OF ILLNESS/INJURY (Check one)				
a. Fatal				
b. Permanent Total Disability. Person can never again do general work.				
c. Permanent Partial Disability. Person loses or can never again use a body part.				
d. Days Away from Work. Person misses one or more workdays, bed rest/on quarters.				
e. Restricted Work Activity. Person is temporarily unable to perform regular duties; light duty/profile.				
f. First Aid Only. Person has one-time treatment of minor injury. (No lost work days)				
g. No injury.				

DA Form 285: Use only for Class A and B on-duty ground accidents

U.S. ARMY ABBREVIATED GROUND ACCIDENT REPORT (AGARI)											
For use of this form, see AR 385-40 and DA Pamphlet 385-40; the proponent agency is OCSA.											
1. TIME & DATE OF ACCIDENT		a. Yr.	b. Mth	c. Day	d. Time	2. PERIOD OF DAY		Day	Night	3. ACCT CLASS	
5. UNIT IDENTIFICATION					a. UIC (6-digit Code)		b. Name of Unit			c. Unit's Branch	
6. LOCATION OF ACCIDENT					a. Exact Location (Detailed enough to locate site)					b. Name of Facility	
c. State/Country		d.	Off Post	On Post	7. EXPLOSIVES/AMMO						
8. MISSION											
a. Briefly describe the mission											
9. VEHICLE/EQUIPMENT/MATERIEL INVOLVED											
Material Failure/Action											
a. Type of Item (Nomenclature)	b. Model #	c. Owner									
#1	#2										
10. WHY DID THE MATERIEL FAIL/MALFUNCTION? (Check the root c.)											
a. LEADER (Not ready; willing to enforce standards)	STOPS/PROCEDURES (Not clear; Not practical)										
Direct Supervision	AR	SOP									
Unit Command Supervision	TM	Other									
Higher Command Supervision	FM	None exists									
11. NAME (Last, First, MI) (Include Address & UIC if different than Bkts 5a & b.)											
21. DAYS HOSPITALIZED	23. CODE	24. SPECIFIC DESCRIPTION OF ACTIVITY/TASK									
22. WORKDAYS	a. Lost										
	b. Restricted										
25. PERSONAL PROTECTIVE EQUIP					26. ALCOHOL/DRUGS CAUSED/CONTR		Yes	No	Unk	27. EQUIP THIS PERSON WAS ASSI	
a. Required	b. Type of equip	c. Available	d. Used	28. LICENSED TO OPERATE EQUIP	29. HRS ON DUTY	30. HRS SLEEP	31. TACTICAL TRAINING	32. TYPE TRAINING FACILITY	33. LAST TRAINING	34. FIELD TRAINING	
<input type="checkbox"/> Yes <input type="checkbox"/> No	#1 #2	#1 #2	#1 #2	<input type="checkbox"/> Yes <input type="checkbox"/> No			<input type="checkbox"/> Yes <input type="checkbox"/> No			<input type="checkbox"/> Yes <input type="checkbox"/> No	
36. DID INDIVIDUAL MAKE A MISTAKE THAT CAUSED/CONTRIBUTED TO ACCIDENT? (In Bkts a, indicate if individual made a mistake. If yes provide the code from instructions.)											
a. Mistake	c. Tell what the mistake was and how it caused/contributed to the accident										
<input type="checkbox"/> Yes <input type="checkbox"/> No	b. Code										

DA Form-285-AB-R: Use for all off-duty accidents and Class C and D on-duty ground accidents

DA FORM 285, JAN 92 CA FORM 285, AUG 92

DA FORM-285-AB-R, JUL 94