

A Reliable Calibration Method for an Ion Current Controlled  
Electron Beam Transition Metal Deposition Source

E. T. Bullock, S. T. Coyle, G. G. Hembree and M. R. Scheinfein,

Dept. of Physics and Astronomy, PSF-470 Box 871504 ASU, Tempe AZ 85287-1504.

Abstract

An alternative ion-current controlled calibration scheme has been implemented for electron-beam transition metal (Co) deposition sources. A repeatable and practical means of positioning the source (tip), measuring the ion-flux and determining the flux rate is given. Intrinsic variations in the structural parameters and thermal effects which can modify the growth rate are examined and compensated for. A stable regime where ion-beam current is directly proportional ( $\pm 5\%$ ) to the growth rate is determined.

Submitted RSI

**DISTRIBUTION STATEMENT A**

Approved for public release:  
Distribution Unlimited

19971209 071

**DTIC QUALITY INSPECTED 4**

## Introduction

Electron beam deposition sources are used extensively for surface science and growth experiments.<sup>1</sup> Typically a metal tip (source) held at high voltage is placed in the proximity of a filament which has been heated by a current. The current emitted by the filament radiatively heats the tip, thermally activating atoms in the source which enter the gas phase, radiate outward, and create a flux of metal ions. One of the main difficulties with this type of source is that it tends to have large variances in deposition rates from deposition to deposition. In order to account for these variances, a thickness monitor is often placed next to the sample so that growth rate can be monitored in real time. In other cases, auger spectroscopy and RHEED are used to monitor the amount of material deposited. When these options are not available and a different real time method for determining the deposition rate must be found.<sup>2</sup>

The calibration method of Jones et al<sup>2</sup> relies on the principal that the flux of evaporated metal atoms which pass through the flux of bombarding electrons cause a small fraction of the metal atoms to be ionized. These ions can be collected on an aperture (with negative potential) in the path of the metallic flux as an ion current and used to determine the flux rate. The magnitude of the ion current is related to the deposition parameters as  $I \sim \int_V F(z) J(z) d^3r$  where  $F$  is the flux of metal atoms,  $J$  is the emission current,  $z$  is the source to filament distance and the volume of integration is over the region subtending all flux trajectories which will strike the collecting aperture. The  $z$  dependence is included only to indicate that  $F$  and  $J$  vary with tip position. If a range of source positions can be found where the ratio  $I/F$  is constant then, the ion current,  $I$ , will

be a direct measure of the flux rate. Such a linear region must be identified and a method of accurately relocating the tip in this region between subsequent depositions must be found. This must be accomplished within the constraints that the tip length decreases with use and the physical structure of the system prohibits direct viewing of the tip. We will demonstrate here that how these requirements can be met. We will also show two methods for compensating for the thermal effects in XTC calibration measurements.

### Experiment

A schematic of our electron beam evaporator is shown in Fig. 1. A cobalt tip floating at 3kV and fastened to a linear motion feedthrough can be positioned with an accuracy of .05 mm along the evaporator axis. A tungsten filament positioned about 6mm from the tip is heated with 4 amps of current. The filament consists of one cylindrical winding of wire with a diameter of about 1cm. Not shown are the electrical feed throughs used for filament current and measurement of the ion current. Also not shown is the rotational feed through used for opening and closing a shutter.

Two apertures are shown in Fig 1. The first is part of the heat shield. The second is electrically isolated, held at  $\sim -27V$  and is used to collect ion current. The first aperture has a slightly larger diameter in order to produce a reasonable ion current (on the order of .1 nA). The size of the second aperture is chosen to ensure a deposition area that is larger than the sample area for a given tip to sample distance. The variable  $z$ , tip position, is measured on the linear motion feed through and  $z_f$  refers to the tip to filament distance. The (1) tip voltage, (2) filament current and voltage, (3) emission current and (4) ion current were directly measured during deposition.

Flux rates were measured using a Leybold Inficon model XTC crystal thickness monitor. One difficulty with the crystal thickness monitor is that it is subject to large thermal drifts which effect measurements for extremely slow deposit rates. Thermal effects due to the electron beam source can yield false readings as high as several ML/min. A deposition where the shutter was not opened is shown in Fig. 2. The false growth rate is evident. Although the initial and final readings of the XTC coincide almost exactly, a resting time of greater than 200 minutes was required for thermal equilibrium to be achieved. The initial dip and final rise in the flux rate were due to a ground loop between the filament and the XTC. It is possible to circumvent these thermal effects in two ways.

The first method had the XTC turned on and allowed to run for 5 to 10 minutes in order to establish a zero value. The filament and tip were subsequently turned on and the tip was allowed to come into thermal equilibrium (about 10 minutes). The shutter was opened for a fixed period of time (5 or 10 minutes) and then closed. Once the shutter was closed, the filament and the tip voltage were turned off and the XTC was allowed to return to thermal equilibrium. The flux rate was computed by taking the difference between the initial and final readings on the XTC and dividing by the deposition time.

The second method has the filament turned up to its deposition value (tip voltage off) while the system comes into thermal equilibrium. This process takes about 80 to 120 minutes as shown in Fig. 3. At this point, measurements of the XTC would strictly coincide with deposited material assuming the filament current was held constant. Once thermal equilibrium was reached, the tip voltage would be applied and the flux would be

measured by recording the film thickness for several minutes and fitting a line to the data. The slope of the line would be the flux rate. Typically, deposition lasting at least 10 minutes were necessary for an accurate measurement of the flux rate.

Finding a suitable location of the tip and being able to locate that position repeatably is fundamental to being able to use the ion current as a measurement of flux rate. Jones et al<sup>2</sup> established a method of determining the tip position. The tip was placed near the filament supporting an emission current well below that which would result in deposition. Then, without changing the filament current or the tip voltage, the tip was slowly retracted and the emission current was plotted as a function of tip position. This results in curves which decay slowly and non-linearly. They found that normalizing the data by plotting the quantity  $d \ln(J)/dz$  vs  $z$  that all curves, irregardless of initial  $J$ , fell onto a single curve with a negative and decreasing slope. This procedure was performed prior to the first deposition when the exact location of the tip was still known. A plot of  $d \ln(J)/dR$  vs  $R$  was made and the slope of the curve at the desired position of  $R$  is noted. Presumably, by repeating this procedure after depositions and seeking the noted slope, the tip can be accurately repositioned.

Unfortunately, attempts to duplicate these results with our apparatus were not successful. The presence of the grounded shroud shown in Fig. 1 had a dramatic effect on the emission current, essentially acting as an electron lens. Starting with the tip near the filament,  $J$  fell off roughly linearly with  $z$ . However, as the tip neared the shroud,  $J$  began to fall exponentially. As the tip was pulled back into the shroud  $J$  leveled off and began to decline linearly again. Our data could be fitted quite well with the following function  $J(z)$

$= a/(1+\text{Exp}((z-b)/c)) + d z + e$ . Sample ion beam current measurements and fits are shown in Fig. 4. The symbols refer to the actual data points and the lines connecting them are the fits. The values of the fit parameter 'b' from the best fit curves using the above equation are indicated. The vertical line corresponds to the average of the three b-values.

In order to locate the tip, three curves were obtained using initial emission currents of .2, .3 and .4 mA and a tip voltage of 2 kV. For clarity the positions of the shroud and the filament are shown above the graph in Fig. 4. The curves were fitted using the equation above and the values of the fitting constant 'b' were averaged. Furthermore, during the first tip position measurement the filament currents used for each emission current were noted and were then used for subsequent measurements. This process was performed before and after deposition periods. The difference between the value of  $b_{\text{ave}}$  before and  $b_{\text{ave}}$  after, was taken as the amount of tip length used. This technique was used during a period of testing and calibration in which over 6 mm of tip was consumed. Upon venting and examining the tip it was found that the error in the expected tip position was less than  $\pm .1$  mm. As will be seen, this is well within the limits needed for an accurate deposition rate.

New tips were presharpener by depositing for about 1 hour at a flux rate of about 1 ML/min in the linear region of J vs z shown in Fig. 4. A stable tip shape was critical for repeatable results. In the linear region of J vs. z, the bombarding current strikes the tip from the sides forming a sharp tip. This process is self stabilizing. That is, at some point a stable tip shape was formed and further deposition caused the tip length to decrease without a change in tip shape. If, however, the tip was pulled back into the nonlinear

region during deposition, the bombarding current was focused onto the end of the tip causing it to dull. No consistent results were obtained with the tip in the nonlinear region. It should be reemphasized that a stable tip shape is critical for repeatable results. Once a desired tip position is found, the tip should be conditioned at that position and subsequent depositions should be carried out at only that position.

Fig. 5 shows a plot of film thickness vs. time. The tip was started at  $z_f \sim 4.5$  mm from filament (12 mm on the micrometer) and retracted by 0.2 mm every 12 minutes. The filament current of 3.65 A was not changed and  $J$  was allowed to fall off linearly with tip position starting at 1.358 mA and ending at 1.302 mA. The ion current was recorded for each tip position. As can be seen in Fig. 5, the flux rate for this entire region was constant. In addition, the measured ion current,  $I$ , for the entire deposition was  $\sim 0.065$  nA with variations no greater than  $\pm 0.002$  nA. It should seem remarkable that  $J$  decreased with  $z$  by exactly the right amount so as to keep  $F$  constant. Upon checking the tip position after this deposition it was found that a total of  $\sim 0.6$  mm of material was removed meaning that the total range of tip positions was  $z_f = 4.5$  mm to  $z_f = 7.1$  mm.

A tip position of 6mm was selected and measurements of  $I$  vs.  $F$  were made using two methods. First, the tip was started at 6mm and not adjusted during the measurement process. The data points for each trial were made sequentially using the 80 to 120 min preheat method described above. The filament current was increased in discrete intervals in order to measure  $F$  for about eight different ion currents in the range from 0.03 to 0.08 nA. From this, a plot of  $F$  vs.  $I$  was made along with a best fit line. This is shown for three of the trials in Fig. 6. The tip position was readjusted between trials using the

method described above. Approximately 0.3 mm of tip was consumed during each trial. The results of the first trial in Fig. 6 show that the tip shape was changing slightly during the deposition period. Note that prior to this deposition, the tip had been at  $z_f = 7.1$  mm. The best fits for the second two trials have a slope of 1.66 ML/min/nA and 1.63 ML/min/nA respectively and each line has a y-intercept less than zero but greater than -0.01 ML/min.

Several individual measurements (single depositions) were made using the no-preheat, 200 min cool down method described above. These results are also shown in Fig. 6. For each measurement,  $I$  was started at  $\sim 0.02$  nA and slowly increased over a period of about fifteen to twenty minutes. When this warm up period was not employed, the flux rate was inconsistently high and for the subsequent deposition it was low, as heating the tip too rapidly effected the tip shape. Total deposition times of ten minutes were used for each data point. As can be seen in Fig. 6, the flux rates for the single depositions agree quite well with those of trials two and three. For each single run the flux rate was slightly higher than those of the linear fitted trials. The best fit line shown included the point (0,0) in addition to the known points with all points given equal weight. The slope of the line was 1.67 ML/min/nA and the y-intercept lied in the same range as those of trials two and three.

### Conclusions

Ion current can be used as measure of flux rate for a cobalt e-beam deposition source. For our evaporator design shown in Fig. 1, operating at  $V = 3$  kV and a tip to filament distance of 6mm, the flux rate was given by the linear relationship  $F = 1.67 I -$

0.005 in ML/min when I is measured in nA. The errors are found to be less than  $\pm 5\%$ .

The necessity of relocating the tip to the position  $z_f = 6\text{mm}$  between depositions has been met. The method is analogous to but not exactly like that of Jones et al<sup>2</sup>. The presence of a grounded shroud effected the J vs. z plots in a way that aided in the location of the tip position. The tip could be relocated with an accuracy of better than  $\pm 0.1\text{mm}$ . In addition, thermal effects associated with the use of a crystal thickness monitor could be compensated for by using proper measurement techniques.

References

1. Jonker, J. Vac. Sci. Techno. A 8 (5) Sep/Oct 1990 3883.
2. Jones, J. Sawler and D. Venus, Rev. Sci. Instrum. 64 (7) July 1993 2008.

Bullock et al  
Rev. Sci. Instr.

## Figure Captions

Fig. 1. CAD drawing electron beam deposition source. Note the grounded shroud containing the tip axis.

Fig. 2. Plot of flux rate vs time due to the thermal effects of a deposition as measured on the XTC. A deposition is conducted for 24 minutes with the shutter closed and then the system is allowed to return to thermal equilibrium.

Fig. 3. Plot of flux rate vs time due to the thermal effects of the filament over an extended period of time as measured on the XTC.

Fig. 4. Plots of  $J$  vs  $z$  for three initial values of  $J$ . The symbols represent the data points and the connecting lines are best fits using the fitting function described in the literature.

Fig. 5. Plot of film thickness vs time for various tip positions. The tip is left at each position for 12 minutes.

Fig. 6. Plots of flux rate vs ion current for sequential increases of filament current (trials) and for single depositions.

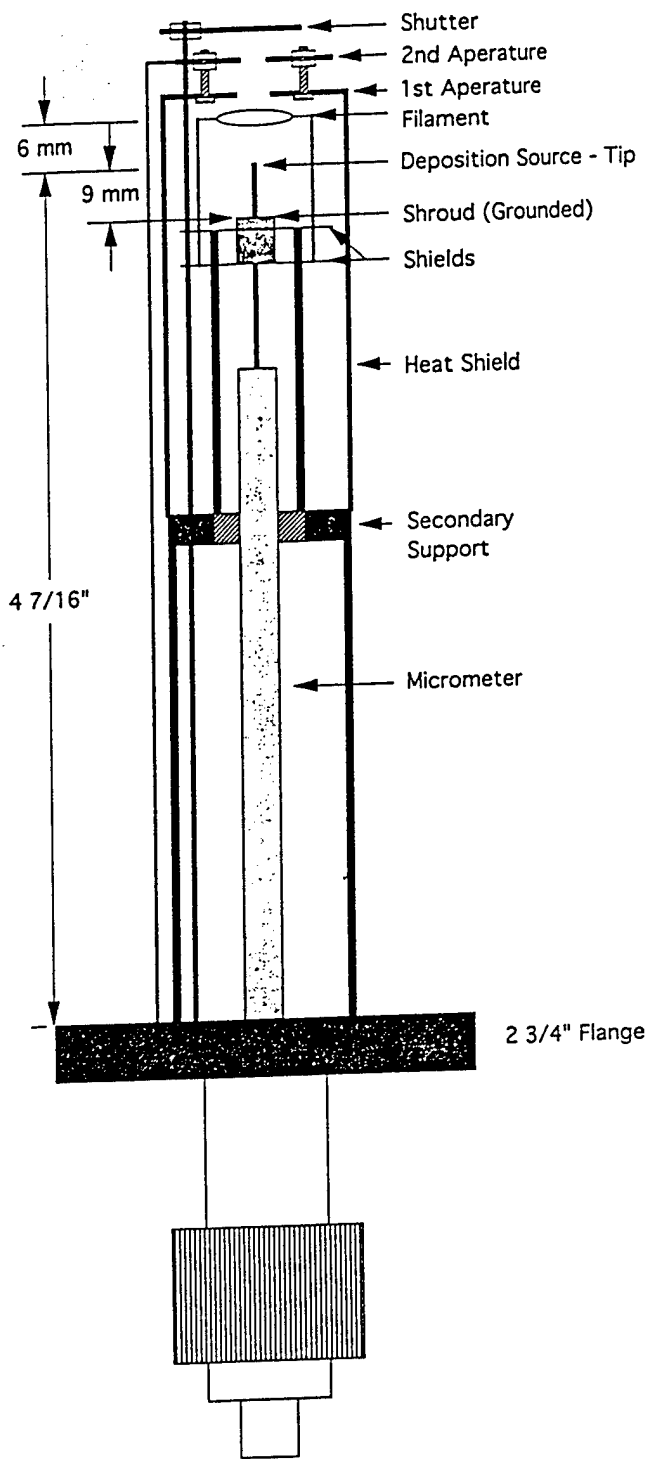

Bullock et al  
 Fig. 1  
 Rev. Sci. Instr.

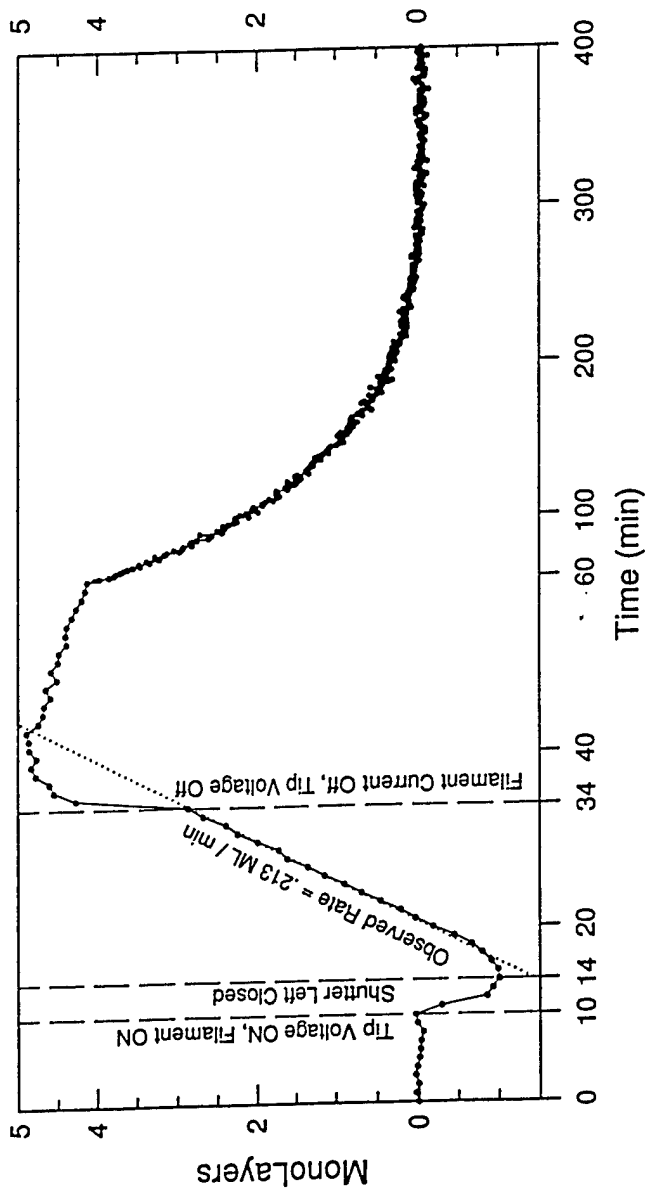

Bullock et al  
 Fig. 2  
 Rev. Sci. Instr.

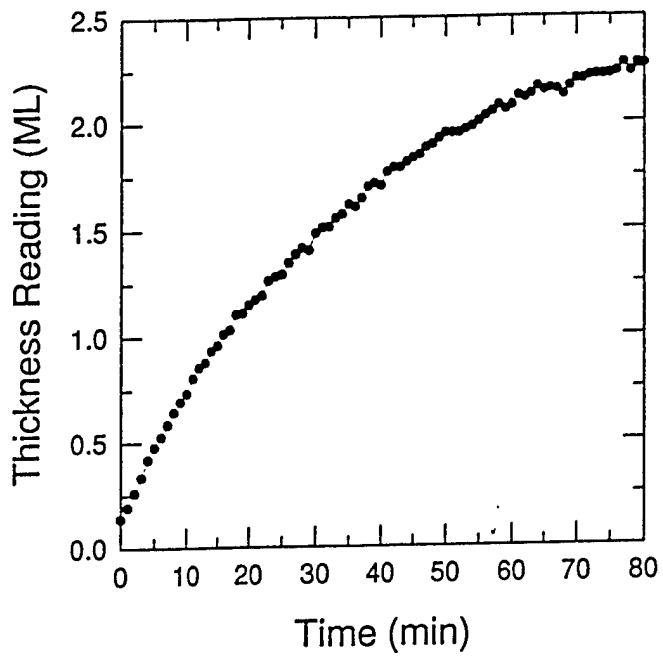

Bullock et al  
Fig. 3  
Rev. Sci. Instr.

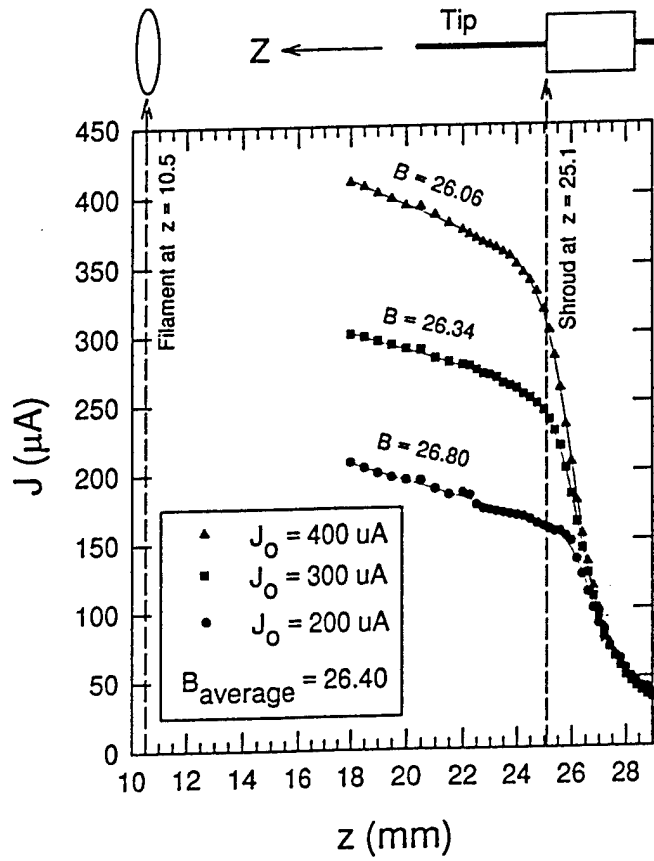

Bullock et al  
 Fig. 4  
 Rev. Sci. Instr.

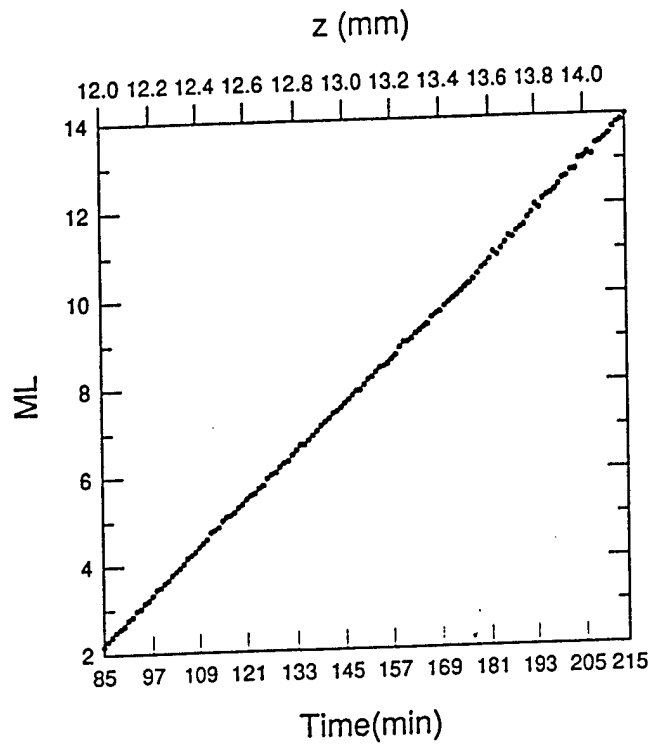

Bullock et al  
Fig. 5  
Rev. Sci. Instr.

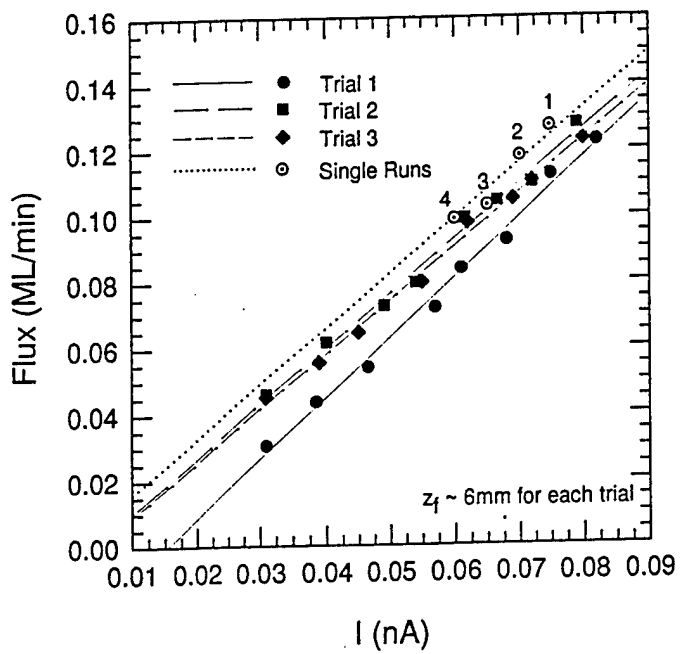

Bullock et al  
Fig. 6  
Rev. Sci. Instr.