

REPORT DOCUMENTATION PAGE

Form Approved OMB No. 0704-0188

Public reporting burden for this collection of information is estimated to average 1 hour per response, including the time for reviewing instructions, searching existing data sources, gathering and maintaining the data needed, and completing and reviewing the collection of information. Send comments regarding this burden estimate or any other aspect of this collection of information, including suggestions for reducing this burden to Washington Headquarters Services, Directorate for Information Operations and Reports, 1215 Jefferson Davis Highway, Suite 1204, Arlington, VA 22202-4302, and to the Office of Management and Budget, Paperwork Reduction Project (0704-0188), Washington, DC 20503.

1. AGENCY USE ONLY (Leave blank)		2. REPORT DATE August 1997	3. REPORT TYPE AND DATES COVERED Final Report		
4. TITLE AND SUBTITLE Lithium Single-Ion-Conductor Film			5. FUNDING NUMBERS F6170896W0222		
6. AUTHOR(S) Prof. Emanuel Peled					
7. PERFORMING ORGANIZATION NAME(S) AND ADDRESS(ES) Tel Aviv University Faculty of Exact Science School of Chemistry Ramat Aviv, 69978, Tel Aviv Israel			8. PERFORMING ORGANIZATION REPORT NUMBER N/A		
9. SPONSORING/MONITORING AGENCY NAME(S) AND ADDRESS(ES) EOARD PSC 802 BOX 14 FPO 09499-0200			10. SPONSORING/MONITORING AGENCY REPORT NUMBER SPC 96-4020		
11. SUPPLEMENTARY NOTES					
12a. DISTRIBUTION/AVAILABILITY STATEMENT Approved for public release; distribution is unlimited.			12b. DISTRIBUTION CODE A		
13. ABSTRACT (Maximum 200 words) This report results from a contract tasking Tel Aviv University as follows: The contractor will investigate the basic charge and mass transport process in CSE, verify the evidence of a different conduction process, and develop improved CSE's by finding ways to increase and decrease anode/CSE and cathode CSE ct problems as per his proposal dated 15/mar/96.					
14. SUBJECT TERMS Electromagnetics			15. NUMBER OF PAGES 31		
			16. PRICE CODE N/A		
17. SECURITY CLASSIFICATION OF REPORT UNCLASSIFIED			18. SECURITY CLASSIFICATION OF THIS PAGE UNCLASSIFIED	19. SECURITY CLASSIFICATION OF ABSTRACT UNCLASSIFIED	20. LIMITATION OF ABSTRACT UL

DTIC QUALITY INSPECTED 4

LITHIUM SINGLE -ION -CONDUCTOR FILM

Contract SPC-96-4020

Final Report for the Period 1.05.96-30.04.97

Submitted by Prof. E. Peled

School of Chemistry

Tel Aviv University

Tel Aviv Israel 69978

August 1997

19971209 022

The Final Report contains three parts:

1. The Interim Report for the Period 1.05.96-31.10.96
2. The new paper entitled: Advanced Model for SEI Electrodes in liquid and polymer electrolytes, submitted to Journal of the Electrochemical Society
3. The measurement of lithium transference number by concentration cell method

COMPOSITE SOLID ELECTROLYTE FILMS

Contract SPC-96-4020

Interim Report for the Period 01.05.96-31.10.96

Submitted by Prof. E. Peled

School of Chemistry

Tel Aviv University

Tel Aviv Israel 69978

January 1997

Introduction

In recent years rechargeable Li-batteries containing solid polymer electrolytes are being extensively investigated because they can offer high specific energy and high discharge rates. The vast majority of studies have been directed toward the development of highly conductive solid polymer electrolytes. However knowledge of the conductivity(σ) alone does not give a true picture of the total PE resistance. More phenomena must be taken into account, such as ion coupling, diffusion and grain-boundary resistance (R_{GB}), especially in the cases of polycrystalline or polyparticle solid electrolytes. LiI-based composite solid electrolytes (CSEs) are inexpensive and the iodide ion is thermodynamically stable against the anode. Recently we have demonstrated that in LiI $P(EO)_nAl_2O_3$ CSEs the conduction mechanism is likely to be governed by interfacial conduction at the grain boundaries which are parallel to the current flow between the solid LiI $P(EO)_3$ complex and the ceramic particles [1]. While it should be emphasized that the dominant impedance component for CSEs ($n \leq 3$), at $T < 90^\circ C$, is grain-boundary resistance (Fig.1a), which is associated with the cross-over of ions from particle to particle through grain boundaries perpendicular to the current flow (or parallel to the field lines) [2,3]. Thus the ways to decrease R_{GB} have to be found in order to use composite solid electrolytes for high-power batteries at moderate temperatures. The goals of the present work were: to elucidate the phenomenon of grain boundaries in LiI $P(EO)_nAl_2O_3$ CSEs ($n < 3$) and to study the effect of Al_2O_3 , plasticizers and inorganic additives and CSE doping (by CaI_2) on ionic conductivity (σ) and R_{GB} .

Experimental

All materials were processed and cells were built inside VAC glove boxes. The LiI-PEO- Al_2O_3 CSEs were cast from acetonitrile solutions and vacuum dried at 120°C . High purity, vacuum-dried components were used for CSEs preparation. Some of the samples were hot pressed at 120°C and 600 kg/cm^2 . All investigations were performed in a 1cm^2 cell, which permitted the sandwiching of a $50\text{-}400\mu\text{m}$ CSE films (gold coated) between SS electrodes. The cells were held under spring pressure inside a hermetically sealed glass vessel. The AC measurements were performed with a Solartron 1255 frequency response analyzer controlled by a 486 PC. The DSC tests were carried out with TA Instruments module 910 and System Controller 2100. DSC runs were recorded at a scan rate of 10 deg/min up to 350°C .

Results and Discussion

According to DSC thermograms at $T < 70\text{-}110^\circ\text{C}$ CSEs with $1.5 \leq n < 3$ are almost solid and T_g decreases with n from 75 to 13°C (Fig.2). The hot pressing is followed by decrease of T_g from 15 to 0.7°C (at $n=2.5$). For CSEs with $n < 3$ the enthalpy of the first endotherm at $110\text{-}120^\circ\text{C}$ was trebled by the addition of 6% of alumina. These DSC data are in a good agreement with the increase of σ with the maximum of $2 \cdot 10^{-4}\text{ S}\cdot\text{cm}^{-1}$ at 6%v/v Al_2O_3 at 120°C . At $n=3$ the effect of alumina is less pronounced. The addition of 0.05 M CaI_2 makes the CSE more rigid and has little or no effect on σ . Similar conductivity was found for hot-press process.

It is interesting to notice that CSEs, containing plasticizers, such as PEGDME and EC are characterized by lower σ values as compared with pure CSEs

(Fig.3). This may be attributed to the decrease of the concentration of defects at the parallel oriented grain boundaries.

As it was mentioned above the total CSE resistance depends crucially on the resistance of perpendicularly oriented grain boundaries. We have found that R_{GB} value decreases with n (Fig.4), which complements the DSC data and it increases sharply with the reduction of temperature for all CSEs. C_{GB} increases with n over all temperature range. Addition of Al_2O_3 up to 18%v/v and doping by CaI_2 (0.05M) was found to increase R_{GB} and to decrease C_{GB} . This causes the impairment of inter-particles contacts and the drop of contact area (Θ). Hot pressing and plasticizers are supposed to improve CSE contacts. Hot pressing causes the R_{GB} drop in about 4 times. It was found also that the values of R_{GB} in CSEs at $T < 90^\circ C$ may be three- to tenfold decreased by small additions of EC and PEGDME (Fig.5). The apparent activation energy of conductance through perpendicularly oriented grain boundaries for $LiI P(EO)_{n \leq 3} 6\%Al_2O_3$ CSEs was found to be 20-30 kcal/mol, regardless of the additives studied and pretreatment of CSE. It is six times as large as for interfacial conduction through parallel oriented grain boundaries. According to SEM micrographs $LiI P(EO)_n Al_2O_3$ CSEs are assembled from hundred of microns separated cells, especially at $n=1.5$ (Fig. 6). After hot pressing of CSE the cells are bonded together. EC and PEGDME do not change the cell size, but cause the accumulation of Al_2O_3 on the CSE surface and at cell boundaries. We believe that this phenomenon may explain some effects of Al_2O_3 on R_{GB} and on σ at $T > 90^\circ C$.

Conclusions

According to the DSC characterization at $T < 70-90^\circ C$ CSEs with $n \leq 3$ are almost solid. In CSEs ($n \leq 3$) at temperatures below $90^\circ C$ the dominant impedance component is R_{GB} . Additions of Al_2O_3 and CaI_2 were found to

increase R_{GB} and to decrease C_{GB} . This causes the impairment of inter - particles contacts and the drop of σ . Al_2O_3 increases CSE ionic conductivity with the maximum of $2 \cdot 10^{-4} S \cdot cm^{-1}$ at 6%v/v Al_2O_3 concentration. The values of R_{GB} at $T < 90^\circ C$ may be three - to tenfold decreased by small additions of EC and PEGDME and hot pressing pretreatment of the CSE. According to SEM micrographs $LiI-P(EO)_n-Al_2O_3$ CSEs are assembled from hundred of microns cells. EC and PEGDME do not change the cell size, but cause the separation of Al_2O_3 and its accumulation on the surface and cell boundaries.

Acknowledgements

We would like to thanks to Dr. D. Golodnitsky, G. Ardel and I. Lavi.

References

1. D. Golodnitsky, G. Ardel, E. Strauss and E. Peled, Y.Lareah and Y.Rosenberg, J.Electrochem. Soc., 1997, accepted for publication
2. G. Ardel, D. Golodnitsky, E. Strauss and E. Peled, Proceedings of the 37th Power Sources Conference (ARL), 1996, NJ, 283
3. G. Ardel, D. Golodnitsky, E. Strauss and E. Peled, The 190th Electrochemical Society Meeting, San-Antonio, 1996, 96-2, 104a.

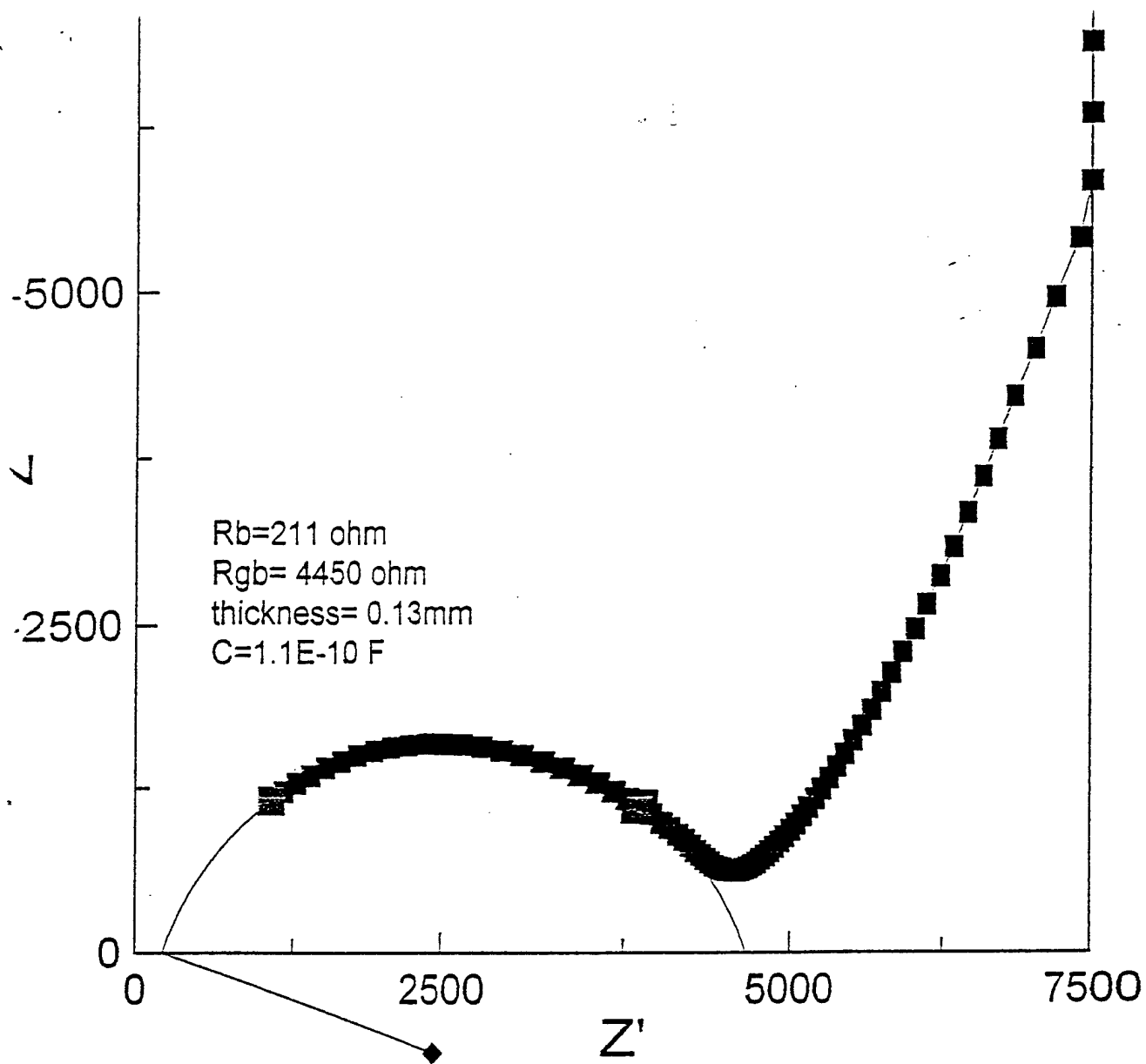

Fig.1 Nyquist plot for LiI P(EO)_{2.5} 6% Al₂O₃
 CSEs at 90 °C

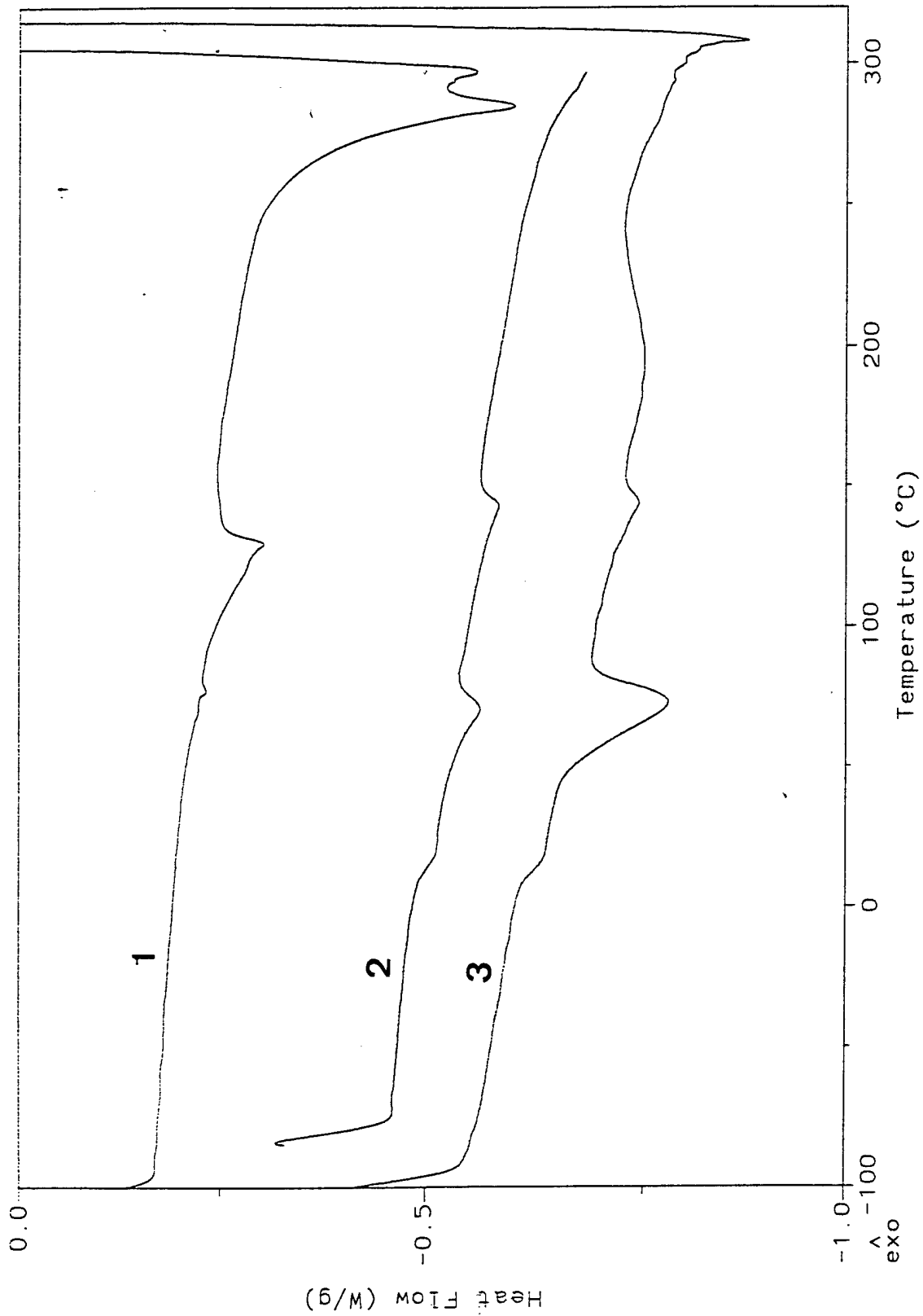

Fig. 2 DSC trace of LiI-P(EO)_n -6% V/V Al_2O_3 based CSEs;

1, n=1 5, 2, n=2 5 3 n=3

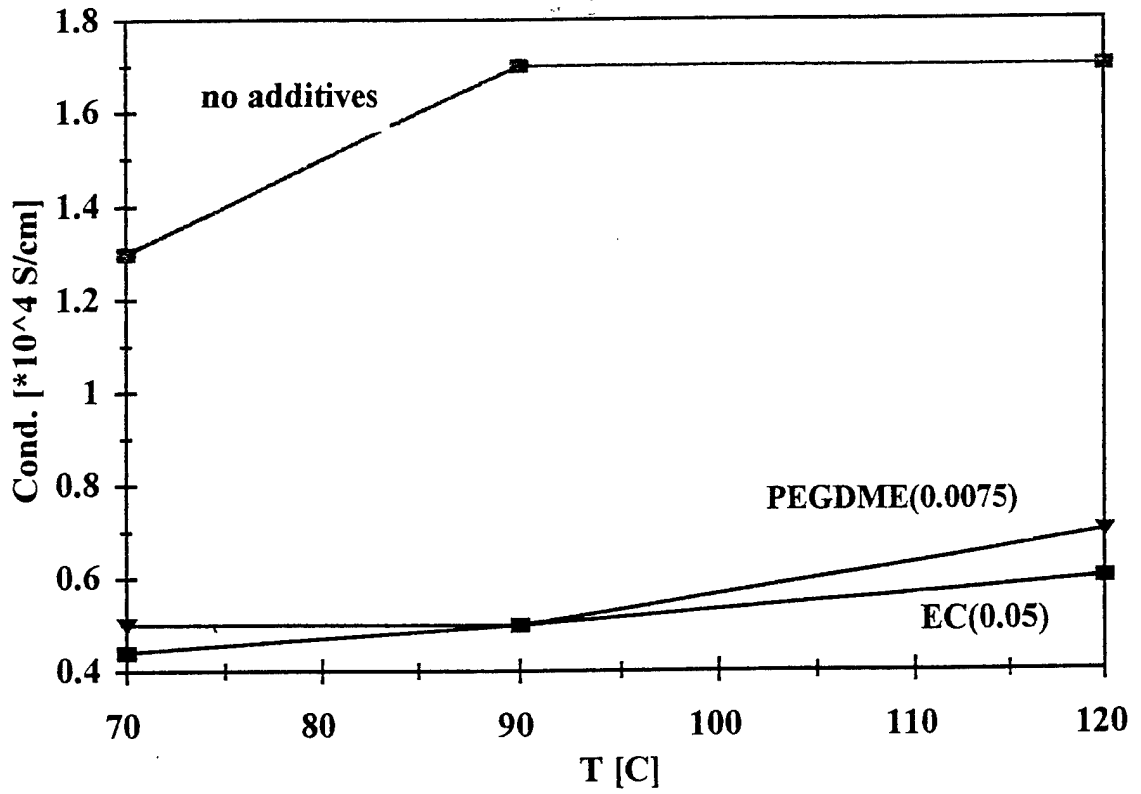

Fig.3

Effect of plasticizers on ionic conductivity of

LiI P(EO)_{2.5} 6% V/V Al₂O₃-based CSEs.

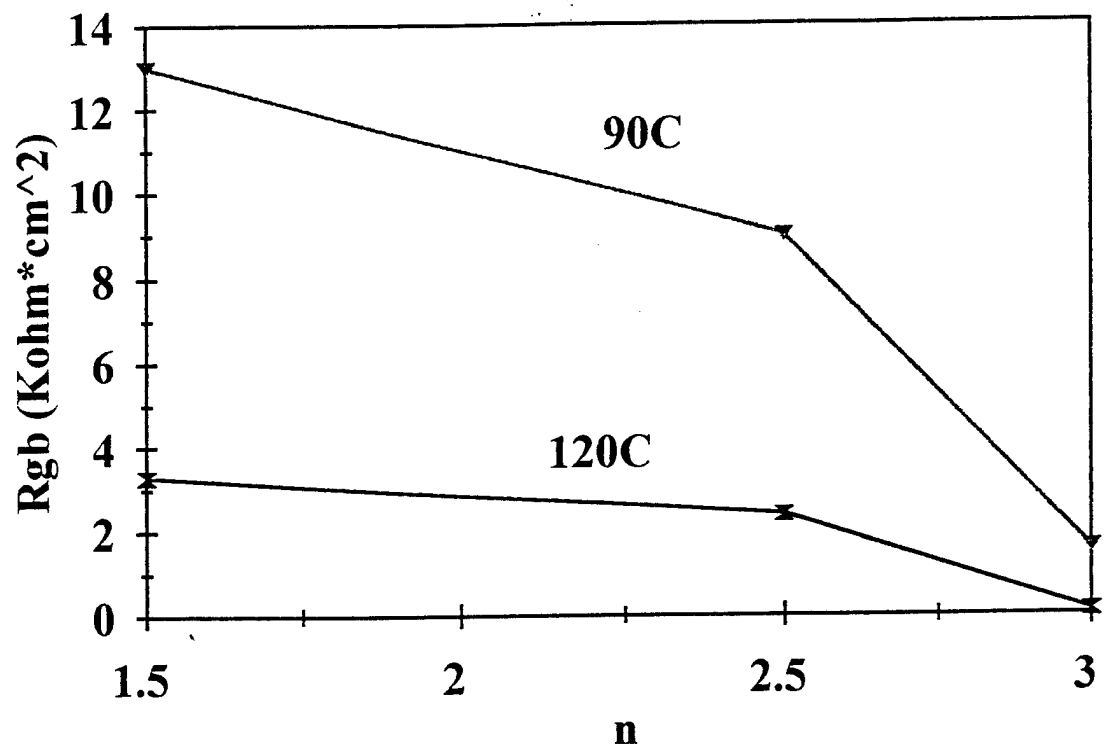

Fig.4 Plot of R_{GB} vs. n in LiI P(EO)_n 6% v/v Al_2O_3 -CSEs

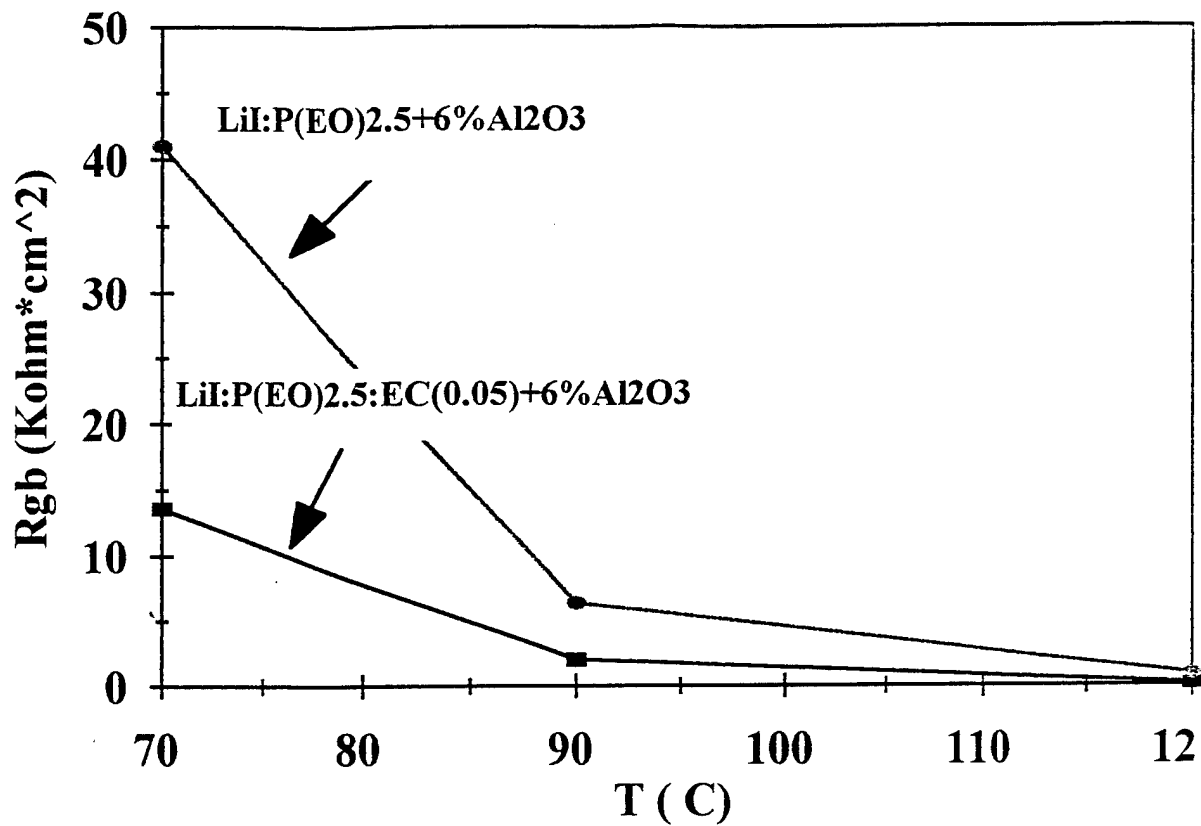

Fig.5 Plot of R_{GB} vs. T in CSEs

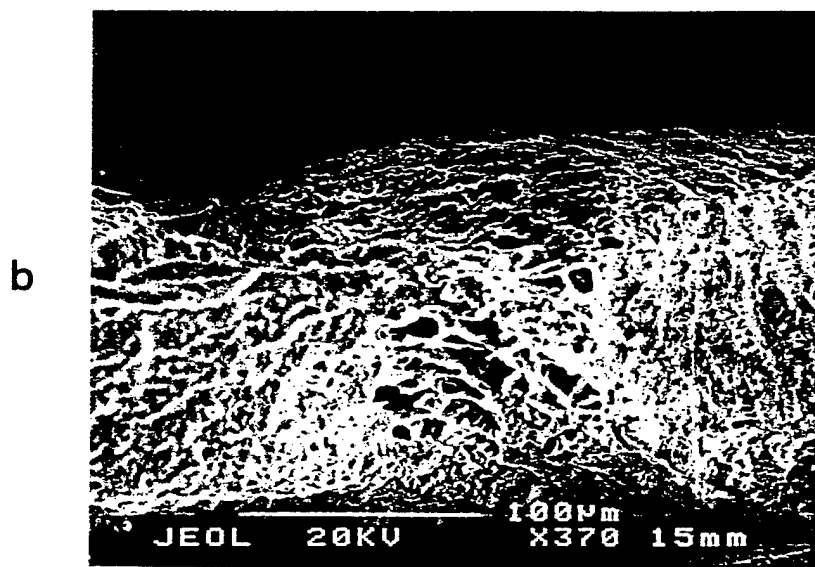
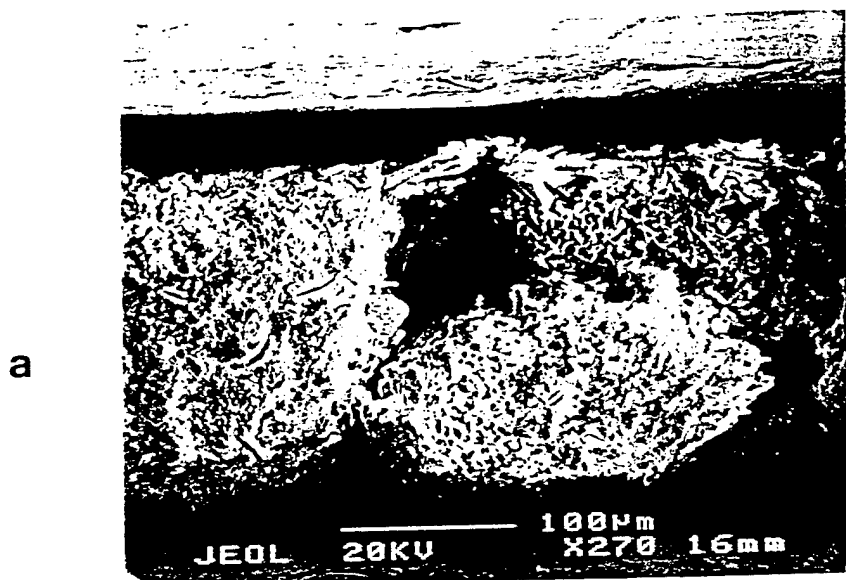

Fig. 6 SEM micrographs of $\text{Li}_{0.9}(\text{CaI}_2)_{0.05}\text{P}(\text{EO})_{2.5}$ 6% v/v Al_2O_3

a- x370 at 20 KV b- after hot pressing

ADVANCED MODEL FOR SEI ELECTRODES IN LIQUID AND POLYMER ELECTROLYTES.

E. Peled, D. Golodnitsky, G. Ardel

School of Chemistry, Tel Aviv University

Tel Aviv, Israel 69978

Abstract

Recent studies show that the SEI on lithium and on Li_xC_6 anodes in liquid nonaqueous solutions consists of many different materials including Li_2O , LiF , LiCl , Li_2CO_3 , $\text{LiCO}_2\text{-R}$, alkoxides and nonconducting polymers. The equivalent circuit for such a mosaic-type SEI electrode is extremely complex. It is shown that near room temperature the grain boundary resistance (R_{gb}) for polyparticle solid electrolytes is larger than the bulk ionic resistance. Up to now, all models of SEI electrodes ignored the contribution of R_{gb} to the overall SEI resistance. We show here that this neglect has no justification. On the basis of recent results we propose here for SEI electrodes, equivalent circuits which take into account the contribution of grain-boundary and other interfacial impedance terms. This model accounts for a variety of different types of Nyquist plots reported for lithium and Li_xC_6 electrodes in liquid nonaqueous and polymer electrolytes.

Results and discussion

It is now well established that in lithium batteries (including Li-ion batteries) containing either liquid or polymer electrolytes, the anode is always covered by a passivating layer, called the Solid Electrolyte Interphase (SEI) [1,2]. The importance of the interphase between the electrolyte and the lithium electrode cannot be overstated and is well recognized in the scientific community and in the lithium-battery industry. In primary batteries, the anode/electrolyte interphase affects the safety, self discharge (shelf life), power capability, low temperature performance and faradaic efficiency of the cell. In secondary batteries it determines, in addition, the faradaic efficiency on charge, cycle life, and the morphology of lithium deposits. For lithium-ion batteries, it also determines the irreversible capacity loss (Q_{ir}) at the first charge cycle.

In the first papers dealing with SEI electrodes [1, 2] it was suggested that the passivating layer consists of one or two layers. The first one (the-SEI) is thin and compact - and the second one (if it exists) on top of the SEI is a more porous, or structurally open layer, that suppresses the mass transport of ions in the electrolyte filling its pores. According to this model, the SEI is made up of ordered or disordered crystals that are thermodynamically stable with respect to lithium.

The SEI resistance (R_{SEI}) in battery electrolytes is typically in the range 10-1000 ohm cm^2 . The grain boundaries (parallel to the current lines) of SEI crystals make a significant contribution to the conduction of ions in the SEI [1, 2]. It was suggested that the equivalent circuit for the SEI consists of three parallel RC circuits in series combination. Later, Thevenin and Müller [3] suggested several modifications to the SEI model: 1) the polymer-electrolyte interphase (PEI) model in which the lithium in PC electrolyte is covered with a PEI which consists of a mixture of Li_2CO_3 , $P(PO)_x$ and $LiClO_4$, where $P(PO)_x$ is polypropylene oxide, formed by reduction-induced polymerization of PC; 2) the solid-polymer-layer (SPL) model - where the surface layer is assumed to consist of solid compounds dispersed in the polymer electrolyte; 3) the compact-stratified layer (CSL) - in this model the surface layer is assumed to be made of two sublayers. The first layer on the electrode surface is the SEI, while the second layer is either SEI or PEI. We believe that the first two models are not relevant to lithium battery systems since the PEIs are not thermodynamically stable with respect to lithium. Perchlorate and fluoro- anions (but not halides) were found to be reduced to $LiCl$ and LiF [4-8]. Recently, Aurbach and Zaban [4] suggested an SEI which consists of five different consecutive layers. They represented this model by a series of five parallel RC circuits representing the capacitance and resistance of each layer. Some of these layers have a thickness of only a few Å, a fact which makes it difficult to assign physical properties such as dielectric constant (ϵ), ionic conductivity, energy of activation, etc. In addition, between each two adjacent layers there is an interface which must be represented by another RC circuit. Thus a model which consists of three different layers with two interfaces seems to be more appropriate to their AC data. In all the previous models for SEI electrodes, the contribution of the grain boundaries has been ignored. We recently found [9,10] that in polycrystalline or polyparticle solid electrolytes (SE), the dominant impedance component is the grain-boundary resistance (R_{gb}), which is associated with the cross-over of ions from particle to particle through grain boundaries perpendicular to the current flow (or parallel to the field lines).

The purpose of this communication is to emphasize the contribution of the grain boundaries to the overall impedance of the SEI on both lithium metal and Li_xC_6 anodes. We propose here a model for such SEI electrodes in liquid nonaqueous and polymer electrolytes.

It is well known today that the SEI on both lithium and carbonaceous electrodes consists of many different materials including LiF , Li_2CO_3 , $LiCO_2-R$, Li_2O , lithium alkoxides, nonconductive polymers and more [4,8,11,12]. Close to the lithium or Li_xC_6 the SEI consists of thermodynamically stable anions, such as O^{2-} , S^{2-} and halides. Close to the solution the SEI also contains partially reduced materials such as polyolefins, semicarbonates, etc. These materials form

simultaneously and precipitate on the electrode as a mosaic of microphases [13,14]. These phases may, under certain conditions, form separate layers, but in general it is more appropriate to treat them as heteropolymicrophases. We believe that Fig. 1 is the most appropriate representation of the SEI. The equivalent circuit of a section of this SEI is presented in Fig. 2.

At a temperature of 90⁰C, the grain-boundary resistance of composite solid electrolytes based on LiI-Al₂O₃ is many times larger than their ionic resistance (Fig.3) and at 30⁰C the enhancement of may be as great as 1000 fold [10]. It can be seen that R_{gb} is several orders of magnitude larger than R_b (the ionic resistance) and for 100 μ thick CSE foils or LiI-Al₂O₃ pellets it reaches 10⁵-10⁶ ohm cm², depending on CPE composition (Fig. 3). The activation energy for conduction through the grain boundaries for LiI P(EO)_{2.5} and LiI P(EO)₃ solid polymer electrolytes was found to be 30 and 35 kcal/mol respectively. This is twice as large as the activation energy for LiI-Al₂O₃ pressed pellets [10]. On the assumption that these solid electrolytes consist of nanometer-sized particles, a value of R_{gb} for a 10 nm thick SEI can be estimated from R_{gb} for CSE, taking into account the thickness ratio (0.01/100). Thus the expected value for R_{gb} at 30⁰C for a 10 nm SEI is in the range 10-100 ohm cm², similar to the experimental values of the passivating-layer resistance [1,2] i.e. it cannot be neglected. In some cases it may be larger than the ionic (bulk) resistance of the SEI. This calculation leads us to the conclusion that R_{gb} and C_{gb} must be included in the equivalent circuits of the SEI, for both metallic lithium and for Li_xC₆ electrodes.

The equivalent circuit for a mosaic-type SEI electrode is extremely complex and requires a very large number of series and parallel distributions of parallel RC elements (Fig. 2). Since the exact composition, size and distribution of these particles are generally unknown, we prefer to make the following approximations: the contributions of R_b of all particles (in the same sublayer) are combined in one term - the apparent SEI ionic resistance, R_{SEI} - and the values of R_{gb} of all the particles in the same sublayer into another term - the apparent R_{gb} of the sublayer. The same is done for C_{SEI} and C_{gb} , and the result is the equivalent circuit shown in Fig. 4 representing a two-sublayer (SL) SEI. $C_{E/SE}$, $C_{1/2}$ and $C_{SE/sol}$ are the double-layer capacitances between, respectively, the following pairs of phases: electrode/solid electrolyte; sublayer 1/sublayer 2; solid electrolyte/solution (or battery electrolyte). R_{ct1} , $R_{1/2}$, R_{ct2} are the charge-transfer resistances between the pairs of phases mentioned above. W represents the Warburg impedance on the solution side of the SEI electrode.

In many cases, the Nyquist plot for SEI electrodes consists of only one, almost perfect semicircle whose diameter increases with storage time (and a Warburg section at low frequencies). For these cases, the following can be concluded: the SEI consists of only one sub-

layer, R_{ct1} , R_{gb} and $R_{ct2} \ll R_{SEI}$, C_{gb} , $C_{SE, sol}$ and $C_{E, SE} \gg C_{SEI}$. Under these conditions, the SEI can be represented by a single RC element - R_{SEI} and C_{SEI} (and the Warburg element). In other cases, aside from the Warburg section, the Nyquist plot can consist of two semicircles [15], many semicircles [4,16], or a shallow arc [17]. For these cases, the equivalent circuit of Fig. 4 or a similar one should be considered.

Summary

The equivalent circuit for a mosaic-type SEI electrode is extremely complex. However to a first approximation one layer SEI is characterized by at least four RC elements in series combination and a Warburg impedance. These RC elements represent two interfaces: electrode/SE and SE/solution, SEI ionic resistance and capacitance, and grain boundaries resistance and capacitance. Each additional sublayer adds another three RC elements. In some cases, the grain-boundary resistance may be larger than the ionic (bulk) resistance of the SEI. The expected value for R_{gb} at 30°C for a 10 nm SEI is in the range 10-100 ohm cm², i.e. it cannot be neglected and R_{gb} and C_{gb} must be included in the equivalent circuit of the SEI, for both metallic lithium and for Li_xC_6 electrodes. We believe that in polymer electrolytes, lithium-passivation phenomena are similar to those commonly occurring in liquid electrolytes.

Acknowledgment

This work was carried out with financial support from the US Air Force Office of Scientific Research and Development and from the Israel Ministry of Defense.

References

1. E. Peled, J. Electrochem. Soc., 1979, 126, 2047
2. E. Peled, in "Lithium Batteries", [Ed: J. P. Gabano] Academic Press, 1983, p.43,
3. J.G.Thevenin and R.H.Muller, J.Electrochem. Soc., 1987, 134, 2, 273.
4. D.Aurbach, and A.Zaban, J.Electroanal. Chem., 1993, 348, 155
5. Y.E.Ely and D.Aurbach, Langmuir, 1992, 8, 1845.
6. K.Kanamura, H.Tamura, S.Shiraishi and Z-i Takehara, J. Electroanal. Chem., 1995, 394, 49
7. M.Odzimkowski and D.E.Irish.J.Electrochem. Soc., 1994,140, 6, 1546
8. M.Odzimkowski and D.E.Irish. J.Electrochem. Soc., 1992, 139, 363
9. G. Ardel, D. Golodnitsky, E. Strauss and E. Peled, Proceedings of the 37th Power Sources Conference (ARL), 1996, NJ, 283
10. G. Ardel, D. Golodnitsky, E. Strauss and E. Peled, The 190th Electrochemical Society Meeting, San-Antonio, 1996, 96-2, 104a.
11. L.Dominey in : "Lithium Batteries, New Materials, development and perspectives, Ed:

G.Pistoia, Elsevier, 1994, p.137

12. D.Bar Tow, E.Peled and L.Burshtein, The 190th Electrochemical Society Meeting, San-Antonio, 1996, 96-2,1028
13. E. Peled, D. Golodnitsky, G. Ardel and V. Eshkenazy, *Electrochimica Acta*, 1995, 40, 2197
14. E. Peled, D. Golodnitsky, G. Ardel, C. Menachem, D. Bar-Tow and V. Eshkenazy, *Mat. Res. Soc. Symp.* 1995, 393, 209
15. N.Takami and T.Ohsaki, *J.Electrochem. Soc.*, 1992,139, 7, 1849.
16. D.Aurbach, I.Weissman, A.Zaban and O. Chuzid (Youngman), *Electrochim.Acta*, 1994, 39, 51
17. S.Fouache-ayoub, M.Garreau, P.V.S.S. Prabhu, and J.Thevelin
J.Electrochem. Soc., 1990,137, 6, 1659

Figure Captions

Fig. 1 Schematic presentation of a polyhetero microphase SEI on lithium or carbon electrode

Fig. 2 Equivalent circuit for the small segment of polyhetero microphase SEI, marked by a dashed line (in order to simplify the scheme other interfaces are not included)

gb - grain boundaries. R_A , R_B , R_C , - ionic resistances of microphases A,B,C. $R_{gb}^{A/B}$, $R_{gb}^{A/C}$

charge-transfer resistances at the grain boundary of A and B or A to C, respectively. C_A ,

C_B , C_C , SEI capacitance for each particles A to C. $C_{gb}^{A/B}$ and $C_{gb}^{A/C}$ -grain-boundary (dl)

capacitance for A/B and A/C interfaces.

Fig.3 Nyquist plot for $\text{LiI P(EO)}_{2.5}$ 6% Al_2O_3 CSEs at 90 °C

Fig. 4 Equivalent circuit for two sublayer polyhetero microphase SEI (for notation see text)

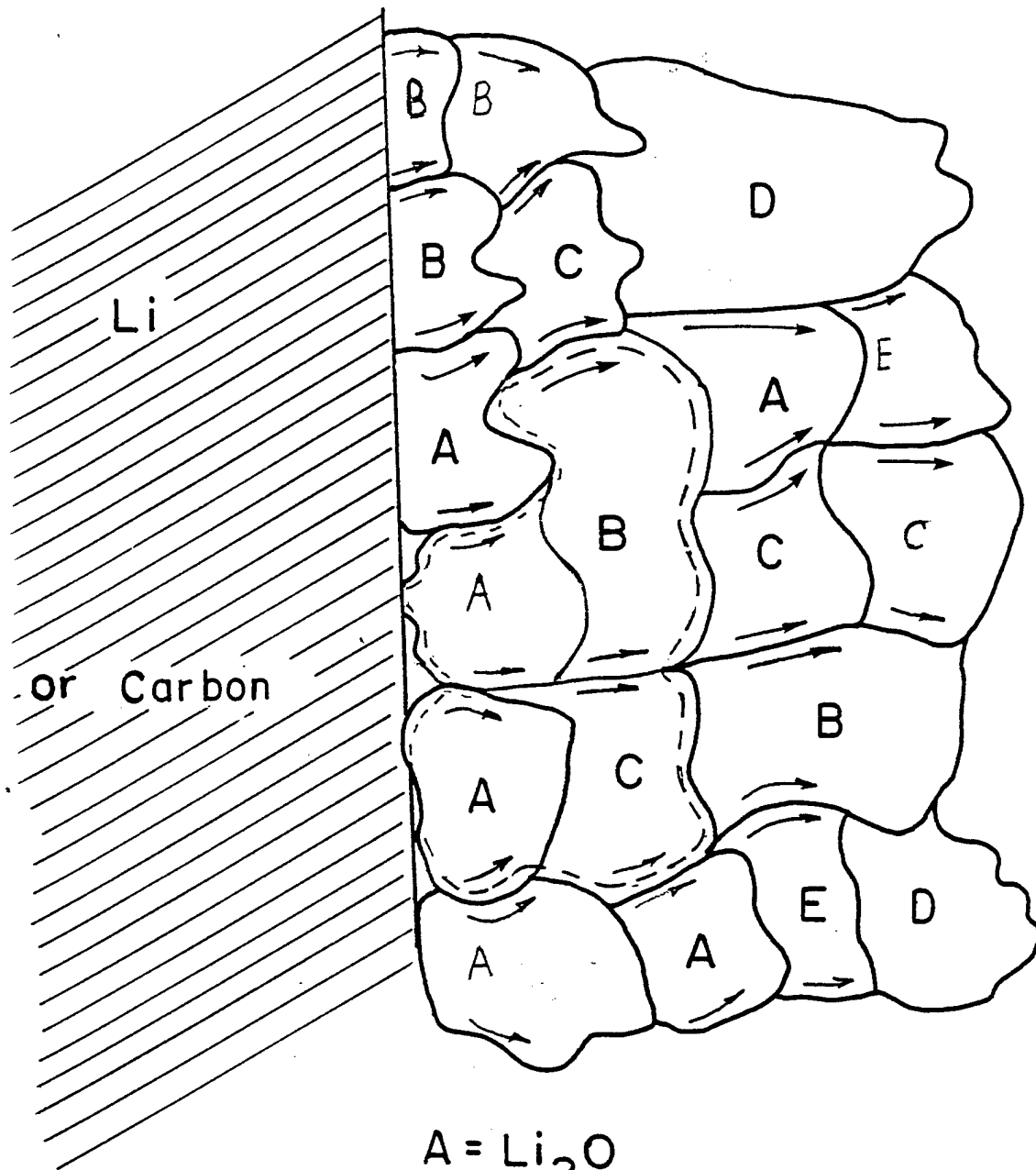

A = Li_2O

B = LiF

C = Li_2CO_3

D = Polyolefins

E = Semicarbonates

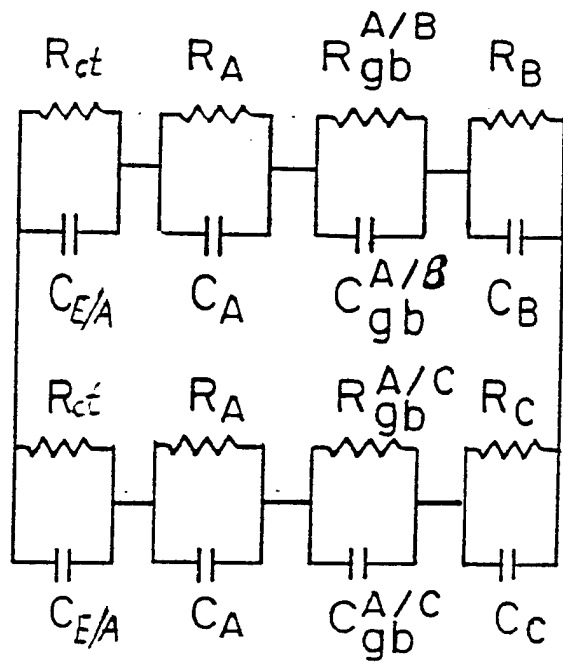

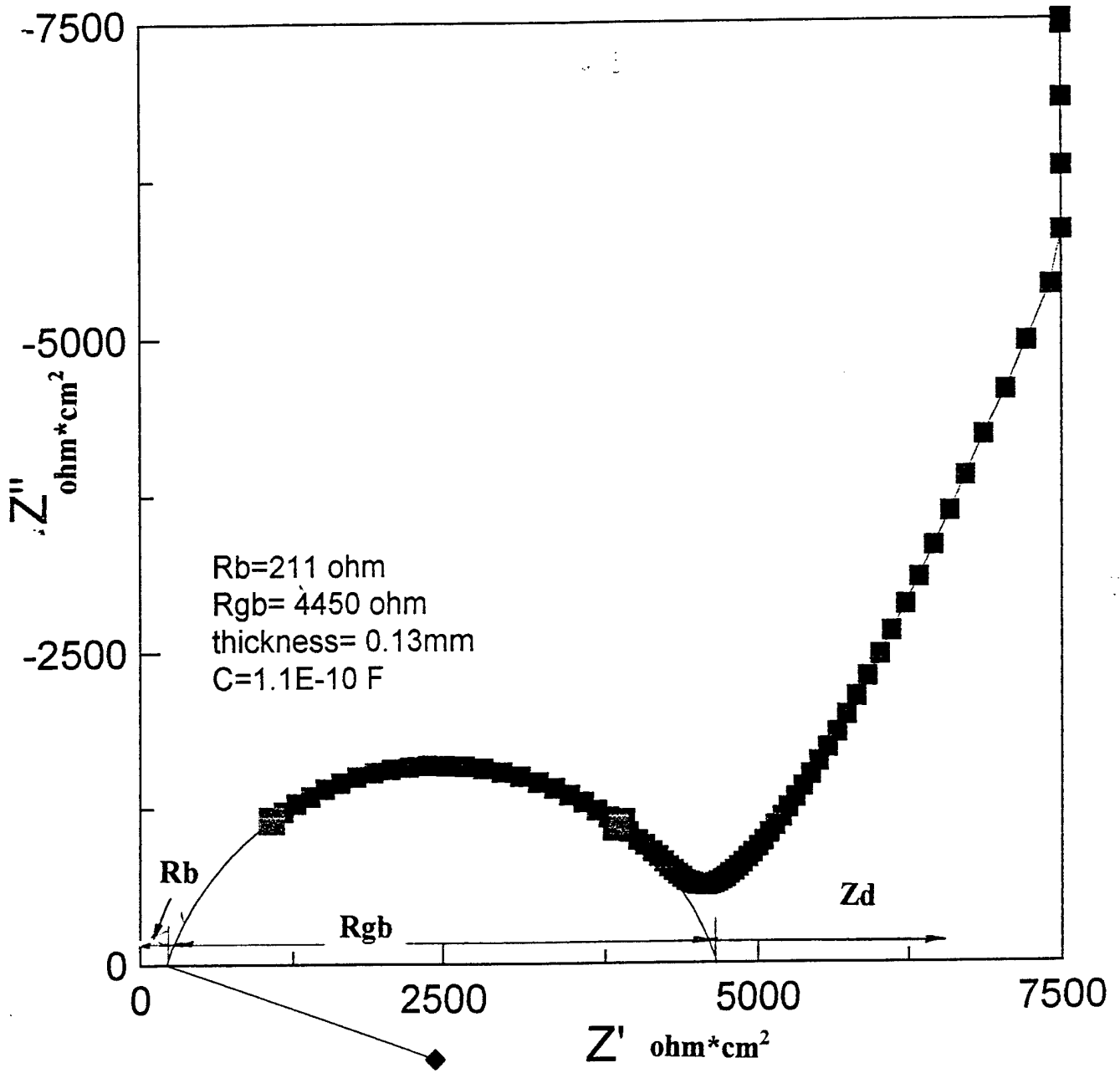

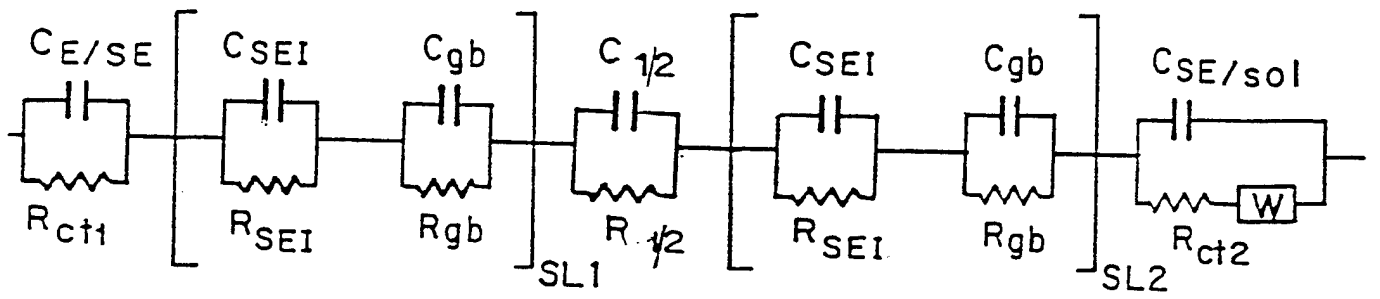

THE MEASUREMENT OF LITHIUM TRANSFERENCE NUMBER BY CONCENTRATION CELL METHOD

Introduction

The vast majority of studies for the last 17 years have been directed toward the development of highly conductive solid polymer electrolytes due to their promising applications in all-solid-state rechargeable lithium or lithium-ion batteries. A central aspect of research on these electrolytes deals with the mechanism of ion transport. Theoretical models for the conductivity mechanism has been proposed (1). Despite this activity the exact conduction mechanism in polymer electrolytes is still a matter of some controversy, but it is commonly agreed that above the melting point of the eutectic (T_m) the effective ionic conduction occurs mainly in the molten phase, and that both ionic species are mobile.

The conduction processes for composite solid electrolytes (CSE, $n \leq 3$) at $T < 60^\circ\text{C}$ are entirely different from those of the CPEs ($n > 3$). (2, 3)

We have demonstrated that in $\text{LiI-P(EO)}_n\text{-Al}_2\text{O}_3$ CSEs with $n < 3$ the conductivity jump in the Arrhenius plots and low E_a values may reflect an interfacial conduction process between the solid LiI P(EO)_3 complex and the ceramic particles (2).

Transference numbers in polymer electrolytes are extremely important for the fundamental studies and for performance of batteries. The determination of real and precise values of ion transference numbers and salt diffusion coefficients can provide more detailed and deconvoluted information on ion transport mechanisms, including ion-ion and ion-polymer interactions.

The formation of multiple ions or ion pairs in composite solid electrolytes decreases the number of charge carriers and may have a significant impact on the charge and mass transport properties of polymer electrolytes. This phenomena gives no way to precise determination of diffusion coefficients and transference numbers. The difficulties of determining the microscopic structure and charge transport behavior in polymer electrolytes is evident from the conflicting conclusions arrived at by a number of researches using a variety of experimental techniques.

It is still unclear what actual species are involved in carrying the electric charge; it has even proved difficult to establish reliably the fractions of current carried by cationic and anionic constituents.

For the electrolyte which dissociates to give a single cationic species, the electric transport number, t_+ , is defined as a number of faradays of charge carried by the cations across the reference

plane (fixed relative to the solvent) when a total of one faraday of charge passes across the plane (4), i.e. for 1:1 salt :

$$t_+ = i_+ / (i_+ + i_-) \quad (1)$$

where i_+ and i_- are the partial currents carried by cations and anions respectively, and i is a total current. While such a definition can be generalized to cover the situation where complex ions exist, it is not of any practical value in situations where there is a fast dynamic equilibrium between the complex ions and their constituents. Ion pairing and the formation of multiplets in PEO-electrolytes was pointed out in crystalline PEO complexes. (5, 6) Thus the nature of the mobile species differ.

Consider a salt M^+A^- dissolved in a polymer host of low relative permittivity, (such as PEO or PPO). Then a series of equilibria are likely to exist in which associated species are formed:



Thus the cation constituent M is carried towards the cathode by M^+ , M_2A^+ , M_3A^{2+} , ... and towards the anode by A^- , MA_2^- , The only quantity that can be measured experimentally is the difference between the fluxes of M -containing species directed towards the cathode and anode, i.e. the net number of moles of M being transferred to one direction. The transference number T_+ is defined as a net number of faradays of charge carried across the reference plane by the cation constituent in the direction of the cathode during the passage of one faraday of charge across the plane. (4, 7)

Several conventional electrochemical methods, such as Tubandt method (8), dc-polarization method (9), "time of flight" method (10) and NMR (11), the pulsed field magnetic gradient method (12), and electrochemical method using microdisk electrode (13) have been applied to measure the various types of polymer electrolytes. While the use of these methods has met with some success, they all involve rather complicated procedures and include a number of assumption and speculations not fully applicable to composite solid electrolytes.

Sorensen and Jacobsen (14) suggested a technique for measuring transport numbers based on the theory of MacDonald (15), which involves analysis of the AC impedance spectra of a symmetrical cell with non-blocking electrodes. The cation transport number t_+ can be calculated (14) by comparison of the width of the skewed low frequency semicircle, Z_d , with the value of the bulk resistance (R_b):

$$t_+ = 1/(1 + Z_d/R_b) \quad (5)$$

Using AC technique (down to about 10^{-2} Hz), we determined (16, 17), for CSEs diffusion impedance (Z_d) close to zero and t_+ close to unity. However in testing Li/CSE/Li cells down to 10^{-4} or even to 3×10^{-5} Hz at 90 - 120°C either erratic results or an increase in Z were found. We suggest that at this frequency range the SEI is being severely affected by the AC signal leading to changes in Z and to errors in the calculation of Z_d , which is solid up to about 120°C . Thus AC method seems to be not applicable to the measurements of transport properties in CSEs.

Determination of Li transference number by E.M.F. concentration cell method were performed by Armand et al. (18) Concentration cells are easy to set up due to the slow salt diffusion, and no special experimental devices are required.

The goal of the present work was to measure with the use of a concentration- cell method the lithium transference number in LiI- Al_2O_3 -based composite solid electrolytes.

Experimental.

All materials were processed and cells were built inside VAC glove boxes. The LiI-PEO- Al_2O_3 CSEs were cast from acetonitrile solutions and vacuum dried at 120°C . Details of the casting procedure are described elsewhere (2). High purity, vacuum-dried components were used for CSE preparation. All investigations were performed in 1 cm^2 cells, which permitted the sandwiching of 100 - $200\ \mu\text{m}$ CSE films between Li or PbI_2 electrodes. The cells were held under spring pressure inside a hermetically sealed glass vessel. The AC measurements were performed with a Solartron 1260 frequency response analyzer controlled by a 486 PC. EMF data were taken by a high-precise digital autoranging microvoltmeter DVM Keithley, 197. The EMF measurements were carried out at 90°C .

Results and Discussion

Preparation of Pb/ PbI_2 electrode

Lead/lead iodide electrodes were first prepared by the electrolysis in a slightly acidified 0.1 M KI solution. In order to get a uniform distribution of the PbI_2 film a low current density of 0.1 mA/cm^2 was used. The Pb/ PbI_2 electrodes were washed with distilled water and vacuum dried at 90°C for 20 h. SEM micrographs (Fig. 1a, 1b) indicate the formation of uniform film built of

small crystals. EDS analysis (Fig.2) show the homogeneous distribution of Pb, I, O elements on the electrode surface.

The resistance of the film measured by AC impedance method was found to be about 2 Kohm cm^2 (Fig.3).

In order to decrease the resistance of the PbI_2 film and to prevent the formation of lead oxides on the Pb/ PbI_2 electrode surface we performed the anode pretreatment of the lead. To produce a high degree of polish of specimens the bath of a following composition was used (19):

Anhydrous sodium acetate	60 g
Glacial acetic acid	315 c.c.
Water	80 c.c.

Polishing occurred at current densities between 50 and 100 mA/cm^2 at room temperature.

A highly reflecting Pb surface appeared after about four minutes. However it should be mentioned, that lead polishing caused the deterioration of the homogeneity of PbI_2 film, which may be due to the decrease of the number of active centers and of the roughness of the surface.

Finally it was concluded to obtain the Pb/ PbI_2 electrodes by simple chemical passivation of lead in KI solution. The resistance of the film was lower (350 ohm) and stable for 84 h (Figs.4 and 5).

PbI_2 seems to have negligible solubility in the PEO- LiI complex. According to cyclic voltammograms (20) and based on our AC measurements Pb/ PbI_2 can be used as a iodide reversible electrode. The voltage of Pb/ PbI_2 /CSE/ PbI_2 / Pb cells was between 4 and 16 mV.

EMF measurements.

Four types of CSE-concentration cells of the following composition were investigated:

1. Li/CSE(1)/ PbI_2 / Pb/ PbI_2 /CSE(2)/Li
2. Li/ CSE(1)/ CSE(2)/Li
3. Pb/ PbI_2 /CSE(1)/Li/ CSE(2)/ PbI_2 / Pb
4. Pb/ PbI_2 /CSE(1)CSE(2)/ PbI_2 / Pb

In order to reduce the effect of the activity changes the LiI concentration in tested CSEs was similar.

CSE compositions:

CSE(1): LiI P(EO)_{2.5} Al₂O₃

CSE(2): LiI P(EO)_{3.5} Al₂O₃

The overall change in the cells #1 and 3 is simply the difference between the changes in the two separate cells i.e. these concentration cells are without transference.

The concentration cells #2 and 4 are with transference: the electrolytes with different concentrations contact each other directly. The electrodes are reversible to Li^+ and Γ , consequently. The major advantage of this method is that there is no need to know the activity coefficient of Li^+ or Γ .

$$E_1 = t_+ \frac{RT}{F} \ln \frac{a_2}{a_1} \quad (6)$$

$$E_2 = \frac{RT}{F} \ln \frac{a_2}{a_1} \quad (7)$$

$$t_+ = E_1 / E_2 \quad (8)$$

Cells were first equilibrated for 3 h at 90°C prior to EMF measurement

Preliminary results are being reported here. Three sets of cells (type 1 to 4) were assembled and tested. Two sets gave similar results to that reported in Table 1. However the third set gave unstable voltages and entirely different results. So in this point we have to study carefully the reasons for this behavior prior to making any final conclusion.

The experimental data of EMF measurements of the four electrochemical cells are presented in Table 1.

	cell 1	cell 2	T_{Γ^-}	cell 3	cell 4	T_{Li^+}
time, h	EMF, mV	EMF, mV		EMF, mV	EMF, mV	
4	-185	9	-0.048	112	140	1.25
17	-180	8	-0.044	102.6	129	1.25
21	-176	7.6	-0.043	101.6	127	1.25
44	-150	6.4	-0.043	98	110	1.13

$$T_{\text{Li}^+} = 129.00 \pm 10 / 102.60 \pm 10 = 1.25$$

$$T_{\Gamma^-} = 8 \pm 1 / (-180 \pm 10) = -0.044$$

The calculations carried out according to the equations (6) - (8) give us the experimental values of lithium transference number equal to 1.25. t_+ was found to be -0.04.

t_+ close to unity indicates that almost all of the charge in LiI-PEO- Al_2O_3 composite electrolyte is carried by lithium cations. This is in agreement with the preferred interfacial conduction mechanism in CSEs, proposed in (2).

We believe that the high (> 1) lithium transference number may be associated with the effect of ion-ion interactions on the macroscopic transport parameters i.e. the positive charge transport of both lithium cations and positive charged complex aggregates. The only explanation proposed at present for the negative value of iodide- anion transference number is based also on the formation of aggregates. According to Newman (21) when mobile positive triplets ions exist, and positive species carry many more iodide-anions and to the opposite direction than free I^- , the transference number t_- may be negative . In addition, the values of transference numbers indicate that the LiI-P(EO) Al_2O_3 - based composite solid electrolyte is highly nonideal.

References:

1. M. A Ratner, in J.R MacCallum, and C.A Vincent, (Eds.), 'Polymer Electrolyte Reviews, 1', Elsevier Applied Science, London, 1987
2. D. Golodnitsky, G.Ardel, E.Strauss, E.Peled, Y. Lareah and Yu. Rosenberg
Conduction mechanisms in concentrated LiI-P(EO)_n-Al₂O₃-based electrolytes, J. Electrochem.Soc, 1997, in press
3. G.Nagasubramaniam, E.Peled, A.I.Attia and G.Halpert, 182-th Electrochemical Soc. Meeting, Canada, Taranto, October 1992.
4. J. Evans and C. A. Vincent and P. G. Bruce, Polymer Vol. 28, 2324-2328, 1987
5. E. Strauss, D. Golodnitsky, G. Ardel and E. Peled,
Electrochimica Acta, (1997), in press.
6. B. L. Papke, M. A. Ratner and D.F. Shriver, J. Electrochem. Soc 129 (1982) 1434.
7. Spiro, M. in 'Techniques of Chemistry', Vol. I, Part IIA, (Eds.A. Weissberger and B. W. Rossiter), Wiley, New York, 1970
8. P. G. Bruce, M. T. Hardgrave, and C.A. Vincent, Solid State Ionics 53-56, 1087(1992)
9. P. G. Bruce and C.A. Vincent, J. Electroanal. Chem., 225, 1 (1987)
10. M. Watanabe, S. Nagano, K. Sanui, and N. Ogata, J. Appl. Phys., 57,, 123 (1993)
11. J. M. Chabagno, Thesis, University of Grenoble (1980)
12. M. Gorecki, R. Andreani, C. Berthier, M. Armand, M. Mali, J. Roos and D. Brinkmann,
5th International Conference on Solid State Ionics. Lake Tahoe, 18 - 24 August 1985,
17,10
13. Jun J. Xu and G. C. Farrington Electrochemical Society Proceedings Vol. 96-17
14. Sorensen, P. R. and Jacobsen, T. Electrochim. Acta (1982), 27, 1671
15. MacDonald, J. R. J. Chem. Phys. (1974), 61, 397
16. G. Ardel, D. Golodnitsky, E. Strauss, E. Peled. The 194th Meeting of Electrochemical Society, Extended Abstracts. 96-2, 104a. San Antonio, Texas, USA, (1996)
17. G. Ardel, D. Golodnitsky, E. Strauss and E. Peled,
In book: Proceedings of the 37th Power Sources Conference (ARL), 283-286, (1996).
18. A. Bouridah, F. Dalard and M. Armand, Solis State Ionics, 28-30, 950, (1988)
19. E.Jones and H.R. Thirsk, Nature, 171, 843 (1953)
20. A. Bouridah, F. Dalard, D.Deroo and M. Armand, J. Applied Electrochemistry, 17, 625, (1987)
21. Y. Ma, M. Doyle, T. F. Fuller, M. M. Doeff, L. C. De Jonghe and J. Newman
J. Electrochem. Soc., 142, 6, (1995)

a

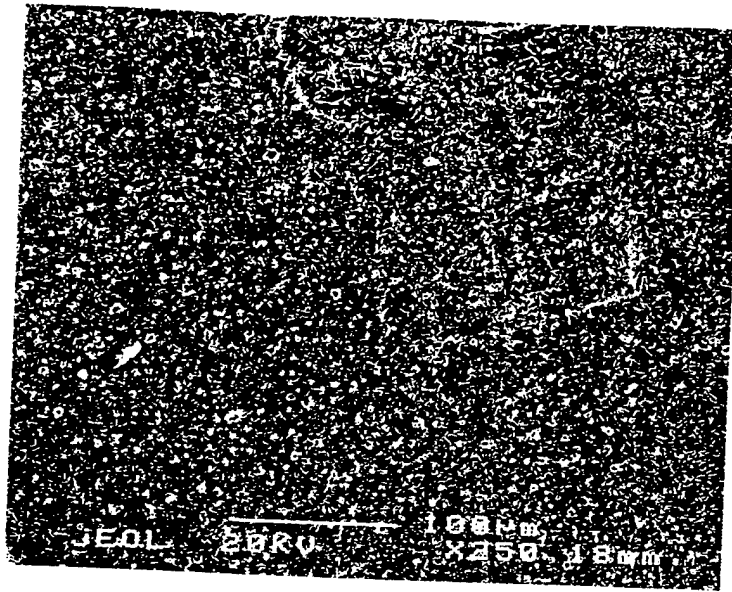

b



Fig. 1 SEM micrographs of:
a- Pb/PbI₂ electrode x 250 at 20 KV
b- Pb/PbI₂ electrode x 4000 at 20 KV

Operator : yossi
Client : none
Job : Gilat
(15/07/97 13:23)

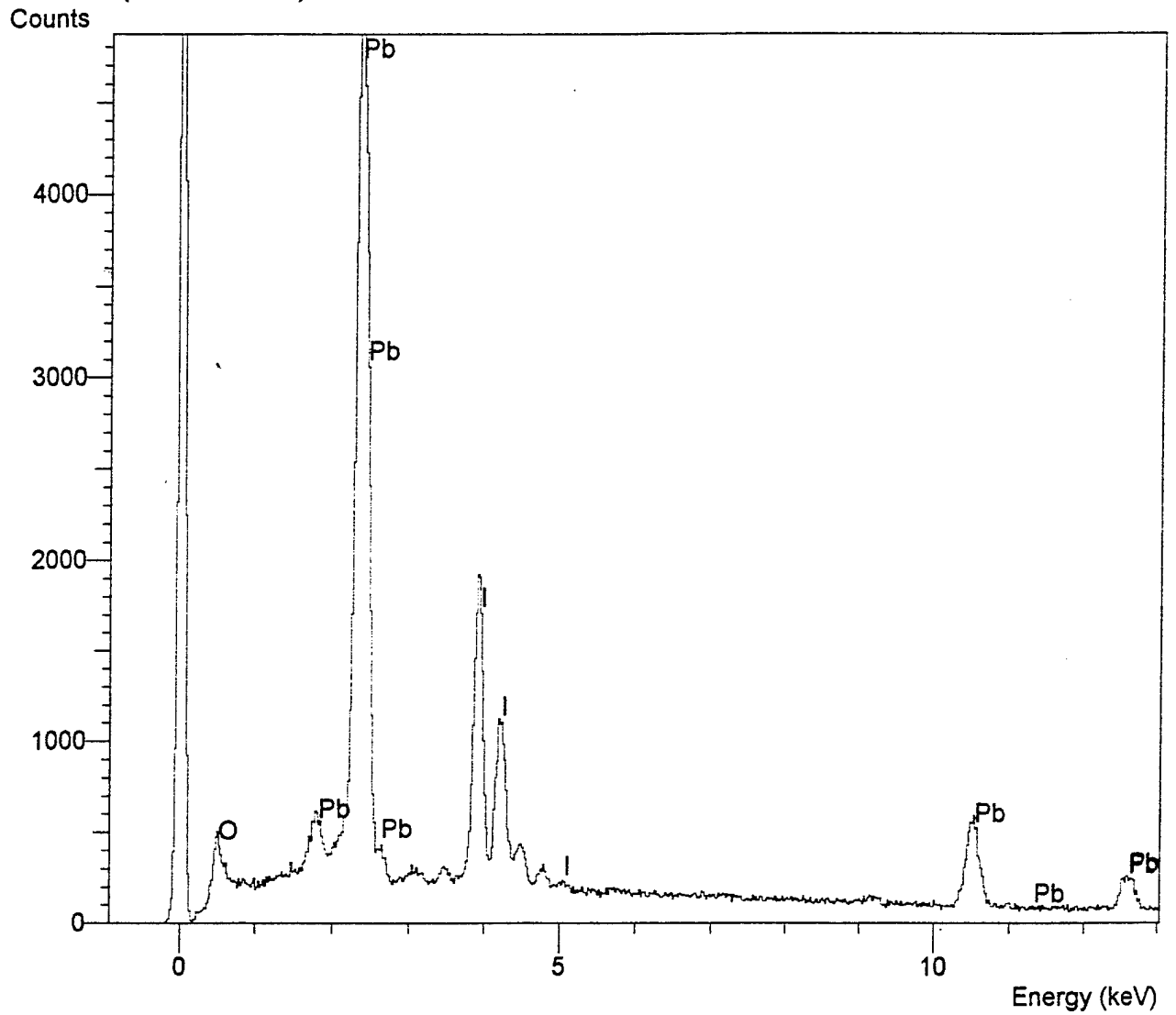
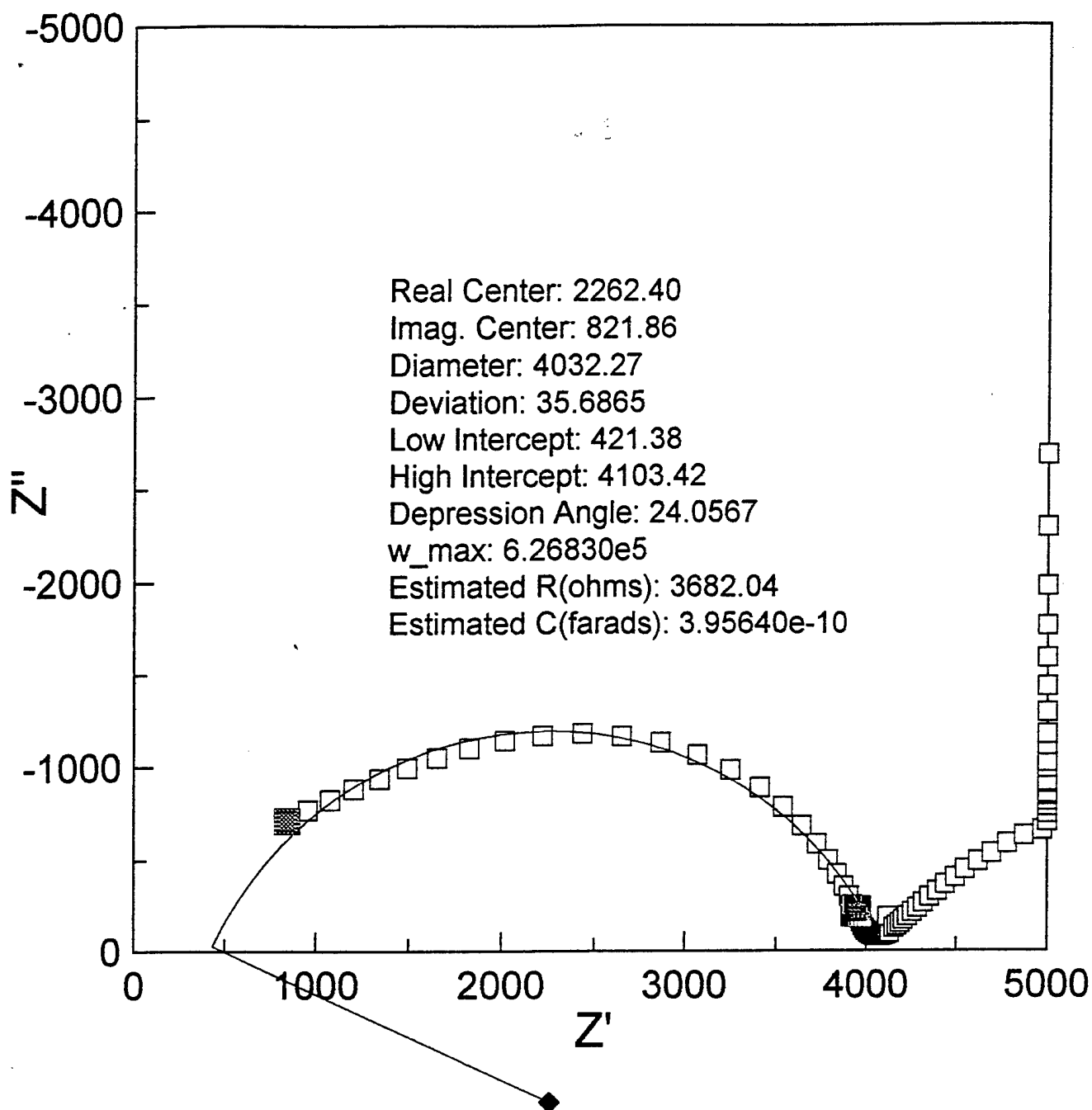
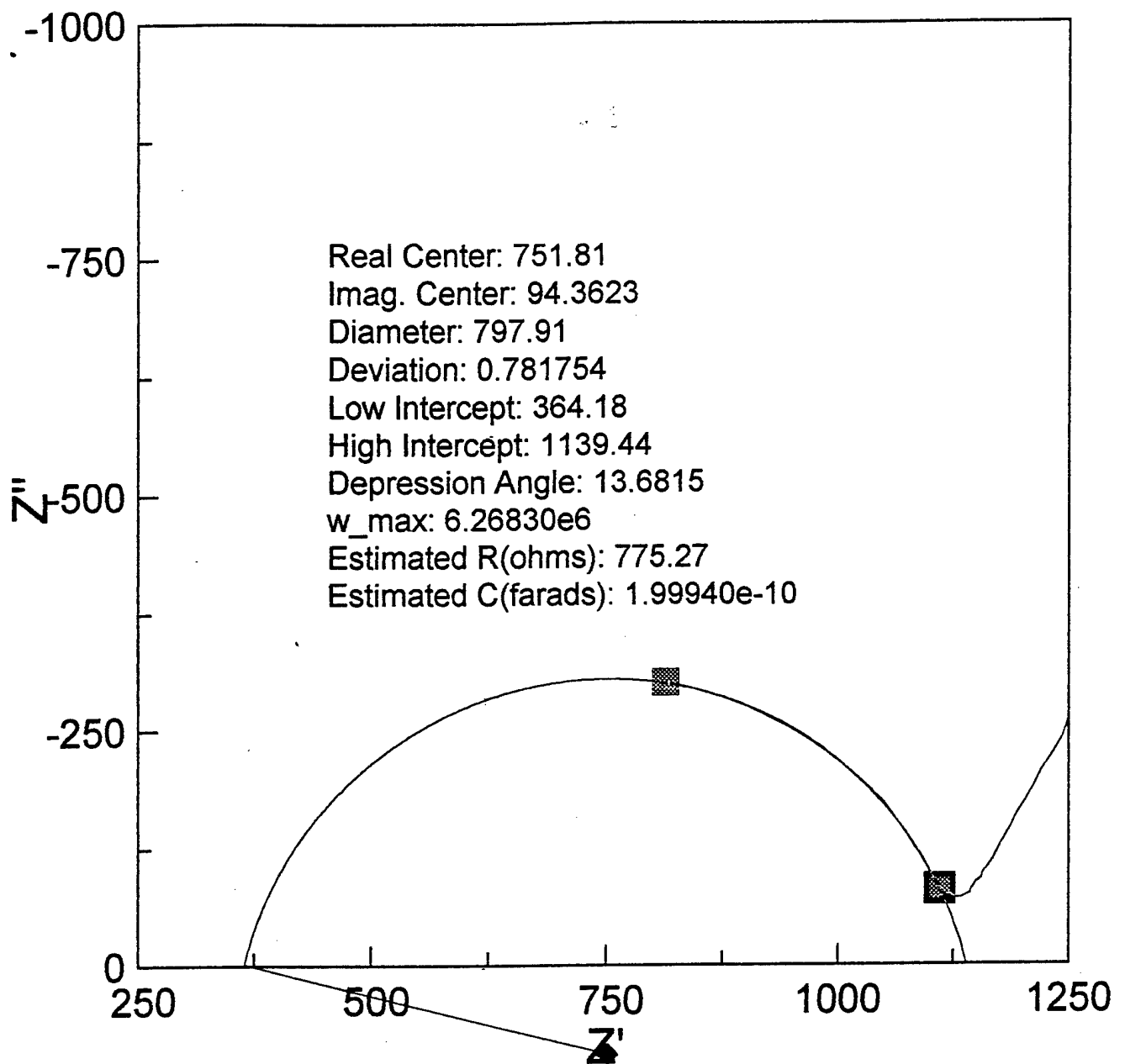

Fig. 2 EDS characterization of Pb/PbI₂ electrode



**Fig. 3 Nyquist plot of Pb/PbI₂/CSE/ PbI₂/ Pb cell at 90 °C,
 CSE composition: LiI P(EO)₃ 6% v/v Al₂O₃
 Pb/PbI₂ electrode prepared by electrolysis**



**Fig. 4 Nyquist plot of Pb/PbI₂/CSE/ PbI₂/ Pb cell at 90 °C,
 CSE composition: LiI P(EO)₃ 6% v/v Al₂O₃
 Pb/PbI₂ electrode prepared by chemical pasivation**

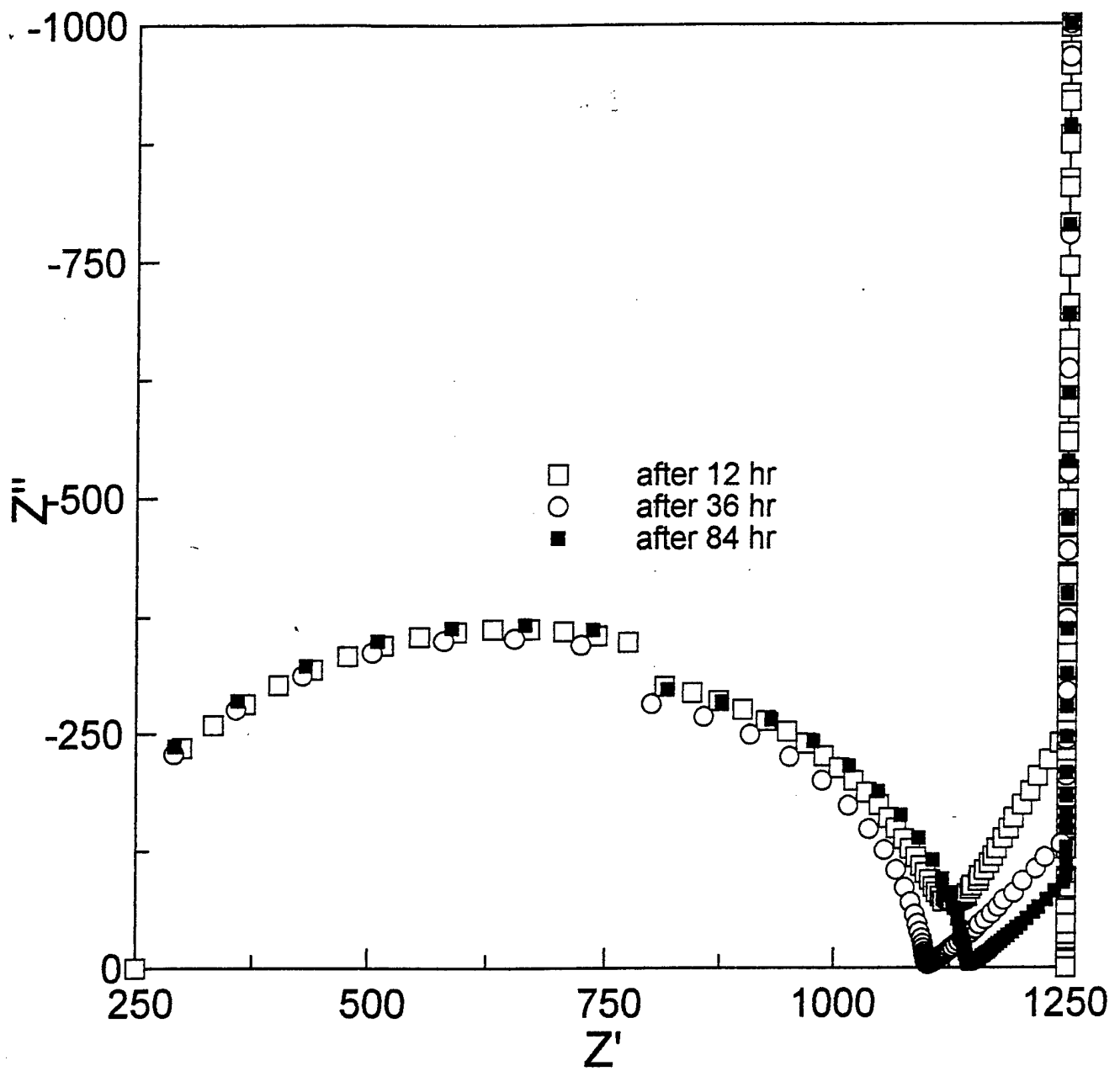

Fig. 5 Nyquist plot of Pb/PbI₂/CSE/ PbI₂/ Pb cell at 90 °C vs. time,

CSE composition: LiI P(EO)₃ 6% v/v Al₂O₃

Pb/PbI₂ electrode prepared by chemical pasivation