

AG.  
REPORT NO. NADC-80177-30

AN/AMT-22 METEOROLOGICAL  
DROPSONDE DEVELOPMENT

**DISTRIBUTION STATEMENT A**  
Approved for public release  
Distribution Unlimited

FINAL TECHNICAL REPORT  
CONTRACT NO. N62269-76-C-034

23 JANUARY 1980

NADC  
Tech. Info.

JMR Systems Corporation  
5 Tinkham Avenue  
Derry, NH 03038

19971215 163

DTIC QUALITY INSPECTED 4

Prepared for  
NAVAL AIR SYSTEMS COMMAND  
Department of the Navy  
Washington, DC 20361

800326

Unclassified

SECURITY CLASSIFICATION OF THIS PAGE (When Data Entered)

REPORT DOCUMENTATION PAGE		READ INSTRUCTIONS BEFORE COMPLETING FORM
1. REPORT NUMBER NADC-80177-30	2. GOVT ACCESSION NO.	3. RECIPIENT'S CATALOG NUMBER
4. TITLE (and Subtitle) AN/AMT-22 Meteorological Dropsonde Development		5. TYPE OF REPORT & PERIOD COVERED Technical Report June 1976 - June 1980
		6. PERFORMING ORG. REPORT NUMBER
7. AUTHOR(s) Hal Jesse Stephen Gilvar Kenneth Smith		8. CONTRACT OR GRANT NUMBER(s) Contract No: N62269-76-C-0304
9. PERFORMING ORGANIZATION NAME AND ADDRESS JMR Systems Corporation 5 Tinkham Avenue Derry, NH 03038		10. PROGRAM ELEMENT, PROJECT, TASK AREA & WORK UNIT NUMBERS 63207N; OW0514CC00; RB302
11. CONTROLLING OFFICE NAME AND ADDRESS Naval Air Systems Command (AIR-370P) Department of the Navy Washington, DC 20361		12. REPORT DATE January 1981
		13. NUMBER OF PAGES 15
14. MONITORING AGENCY NAME & ADDRESS (If different from Controlling Office) Naval Air Development Center (Code 3044) Jacksonville and Street Road Warminster, PA 18974		15. SECURITY CLASS. (of this report) UNCLASSIFIED
		15a. DECLASSIFICATION/DOWNGRADING SCHEDULE
16. DISTRIBUTION STATEMENT (of this Report)  Approved for Public Release. Distribution Unlimited		
17. DISTRIBUTION STATEMENT (of the abstract entered in Block 20, if different from Report)		
18. SUPPLEMENTARY NOTES		
19. KEY WORDS (Continue on reverse side if necessary and identify by block number) Sonobuoy CAPS Pressure Sensor Bathythermograph Thermistor Hygristor		
20. ABSTRACT (Continue on reverse side if necessary and identify by block number) This technical report documents the design changes that were incorporated into the dropsonde as a result of field tests conducted during the development of the dropsonde. Design changes to improve future dropsonde production models are also proposed. This report also summarizes the laboratory and engineering field test results from the development phases of the dropsonde program.		

DD FORM 1473  
1 JAN 73

EDITION OF 1 NOV 65 IS OBSOLETE  
S/N 0102-LF-014-6601

Unclassified

SECURITY CLASSIFICATION OF THIS PAGE (When Data Entered)

TABLE OF CONTENTS

INTRODUCTION	1
DISCUSSION	1
DROPSONDE DESIGN RECOMMENDATIONS	6
FUTURE DROPSONDE STUDY RECOMMENDATIONS	9
CONCLUSIONS	10
REFERENCES AND ENCLOSURES	11
<u>ENCLOSURE 1</u>	
DROPSONDE DESIGN MODIFICATIONS RECOMMENDED FROM KEY WEST TEST RESULTS	12
<u>ENCLOSURE 2</u>	
DROPSONDE DESIGN MODIFICATIONS RECOMMENDED FROM WARREN GROVE TEST RESULTS	14
<u>ENCLOSURE 3</u>	
TIMER MECHANISM DESIGN MODIFICATIONS RECOMMENDED FROM LAKEHURST TEST RESULTS	15

INTRODUCTION

Contract Number N62269-76-C-0304, to design, develop, and manufacture 110 AN/AMT-22 dropsonde systems, was awarded to JMR Systems Corporation by the Naval Air Development Center in June 1976. The dropsonde systems were to be designed in the form figure of existing "A"-size sonobuoys and be capable of being CAD (Cartridge Actuated Device) launched at an airspeed/altitude profile of 200 to 400 knots at altitudes ranging from 3,500 to 40,000 feet. The dropsonde descent rate was intended to be  $1,700 \pm 100$  feet per minute. The dropsonde contains sensors to detect and measure the meteorological parameters of temperature, humidity, and barometric pressure. Information from these sensors is converted in the sonde to frequency modulate a standard SSQ-41 sonobuoy transmitter. The received RF signal is then demodulated and tape recorded for analyzation and processing by a ground and/or airborne station.

DISCUSSION

The initial design effort was completed in late 1977. Nine dropsonde units were delivered to NAVAIRDEVGEN for drop tests at the Key West Test site in February 1978, after all had satisfactorily passed laboratory bench tests. However, the drop tests revealed problems with (a) the deployment of the drogue chute on four of the nine drops, (b) sensor malfunctions, and (c) noisy, erratic, and marginal SNR (signal-to-noise-ratio) transmissions (Reference A). As a result of these tests, several mechanical and electrical modifications were implemented into the design.

Nine dropsondes were next supplied for mechanical testing of the deployment sequence after incorporating design modifications to the timer mechanism, parachute deployment system, and the antenna housing that were recommended as a result of analysis of the Key West test data (Enclosure 1). However, not all of the suggested changes could be incorporated without major redesign. For example, the criss-crossed waxed nylon cord, added to the canister housing to protect the sensors, lasted temporarily until the sensor mount was recessed (refer to Enclosure 1, item no. 4 of instrument package). These nine test units were fabricated in the mechanical mode only, with the electronics package replaced by equivalent weights to achieve the proper over-all weight and center of gravity of the full-up dropsonde. This modification was done to conduct low altitude (1,000 feet) drops over land in order to closely monitor and observe the sonde deployments, and subsequently recover the sondes for analysis purposes. Nine units were dropped at Warren Grove, New Jersey in July 1978. Reported test results (Reference A) indicated that launches at the P-3C maximum speed (330 knots) all failed, while five of six drops at airspeeds of 250 knots or less were successful. A major source of these failures was the timer mechanism. The timer mechanisms used in these drops were constructed from hand-machined parts that were individually fit and were not interchangeable. In addition, marginal drogue and main chute shroud line strengths also contributed to failures at the upper end of the launch envelope. Again, a number of design changes in the mechanical deployment subsystem of the dropsonde were recommended after analysis of these drop

test results (Enclosure 2). The sondes were subsequently refurbished and the recommended changes were implemented to the maximum extent possible, considering that the timer units were still of the hand-fit variety.

The nine units were subjected to low altitude air drops again in September 1978 at the NAS Lakehurst, N. J. parachute range site. The tests revealed satisfactory results on three of four drops at 300 knots or less, while three of five drops at 325 knots or above failed (Reference A). Again, drop analysis indicated the main cause of failure to be the timer mechanism and the chute lines. Design modifications to the mechanical deployment system were again recommended (Enclosure 3).

Concurrently with preparation of the units for the Lakehurst drops, five dropsondes with full-up electronics were constructed for system testing at Cape Hatteras in September 1978. These units again were fully tested and evaluated in the laboratory prior to deployment. The reported results showed that all five units performed satisfactorily in deployment and RF and data transmission with close correlation to corresponding National Weather Service rawinsonde data obtained from Cape Hatteras (Reference A).

As a result of the previously mentioned test program, the dropsondes were considered to have demonstrated satisfactory performance, and that both mechanical and electrical design risks and problems had been identified, corrected, and minimized. The units were released for pre-production based on implementing all the design changes indicated by the development test program and the inclusion of additional electrical and drop testing of the first units assembled from parts furnished by production

tooling. The only design recommendation not implemented at this time was "e" in Enclosure 3; a decision based on cost savings rather than any functional defect in the evaluated samples.

During the latter part of 1978, discussions were held with NAVAIR-DEVCEN and Honeywell, Inc. concerning the feasibility of replacing the existing baroswitch (a discrete pressure measuring device) in the dropsonde with the proprietary Honeywell Continuous Analog Pressure Sensor (CAPS). Discussions were also held with NAVAIRDEVCEN concerning the feasibility of providing space and weight allowance in the dropsonde for later incorporation of bathythermograph (BT) and wind-sensing capabilities. Preliminary design and engineering studies indicated that both of the above were feasible. NAVAIRDEVCEN formally directed both the incorporation of the CAPS package into the dropsonde, and the physical layout changes required to provide space for possible BT and wind-sensing capabilities. These modifications resulted in major design changes and program delays, as well as imposing a requirement for additional drop tests to requalify the revised system.

All of the mechanical design changes, including those to the timer mechanism, were implemented in ten electrically inert pre-production tooled sondes that were field tested at Lakehurst in December 1979. As a result of the successful demonstration of meeting specified performance, the deployment system was accepted (Reference B).

Ten complete functional ADM (Advanced Development Model) dropsondes were fabricated and shipped to PMTC (Pacific Missile Test Center), Point Mugu, California for First Article drop tests in January 1980. The analysis

of the received meteorological data has not been fully completed; however, initial indications are that of the units that functioned properly, the data obtained were accurate. Three of the ten units launched failed in that the main chute did not open; however, they functioned electronically and transmitted valid data during their high speed descents.

Since these drops were made over water, visual and camera ground observations were not obtained. The only visual record of the drops was that obtained from the camera pod located at the wing of the P-3C aircraft. However, these aircraft films could only obtain the drogue chute deployment portion of each launch. Determining the cause of the three sonde failures was thus made more difficult by the non-recovery of the failed units. As the battery lanyard cord had been omitted from the electrically inert units dropped and qualified at Lakehurst (December 1979), investigations centered on the possibility of it causing the failures. Bench tests indicated that the drogue chute could pull the lanyard cord plug out of its phone jack an excess amount, thus pinching the main chute cover bag. This effect, in turn, transmits uneven pressure to the base of the timer unit. Upon release of the timer, this uneven pressure causes it to cant to one side within the antenna housing and jam, thus preventing main chute deployment. Lengthening the battery lanyard cord by two inches reduces the nominal travel of the lanyard plug from three inches to one inch. This modification provides sufficient travel to pull the plug and energize the

dropsonde electronics without pinching the main chute. The lengthened lanyard change has been implemented into the 100 pre-production dropsonde units that have been fabricated and delivered to the NAVAIRDEVCON for TECHEVAL.

#### DROPSONDE DESIGN RECOMMENDATIONS

As a result of analyzing the failure modes previously enumerated, a number of revisions for future implementation, most of which being too late to be incorporated into these 100 units, have been proposed:

(1) The profile of the lanyard pin release cam had originally ridden against the spring loaded moisture cover of the phone jack. It was found that the spring prevented smooth removal of the lanyard pin, thus forcing the cam, at times, to have an uneven contact with the cover and the lanyard pin to be "pushed" by the cover when the former is partially removed. (see Diagram 1). Also, to prevent the possibility of any excess lanyard cord material (beyond where the knot secured the cord to the release cam) either dislodging the cam from its position, or otherwise fouling the release action; because of the insertion of the main chute assembly, the knot may be eliminated and the cord heat sealed (mushrooming the end) at assembly to attach the cord to the cam. Since no parts had to be changed to implement this revision, it was incorporated into the 100 units.

(2) The moisture cover does not completely close because the thickness of the antenna platform allows too much of the threaded portion of the jack to protrude through into the interior of the antenna housing.

DIAGRAM 1

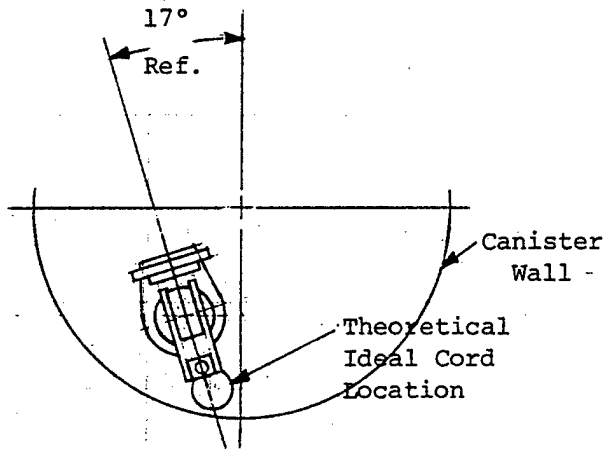

ORIGINALLY PROPOSED DESIGN  
(per Dwgs. Supplied)

Advantages: (1) Good Cord Location

Disadvantages: (1) Uneven cocking of lanyard pin during removal due to action of spring loaded jack cover on shaft connecting pin to cam  
(2) Possible pinch of bag/chute against canister wall.

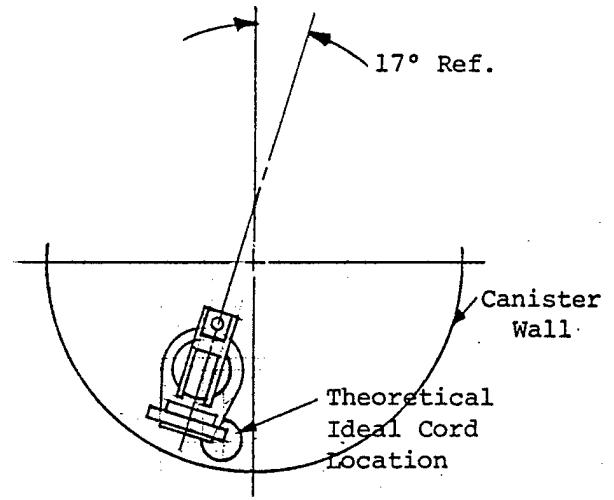

100 DELIVERED UNITS

Advantages: (1) Eliminates possible pinch of bag/chute against canister wall.  
Disadvantages: (1) Poor cord location.  
(2) Uneven cocking of lanyard pin during removal due to action of spring loaded jack cover on shaft connecting pin to cam.

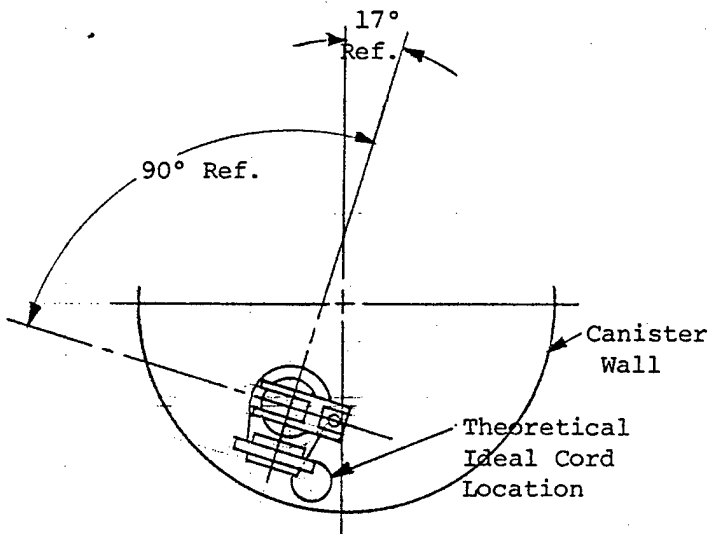

RECOMMENDED DESIGN  
(Modifying Assembled Units)

Advantages: (1) Good cord location  
(2) Eliminates possible pinch of bag chute against canister wall.  
(3) Prevents uneven cocking of lanyard pin during removal due to action of spring loaded jack cover on shaft connecting pin to cam.

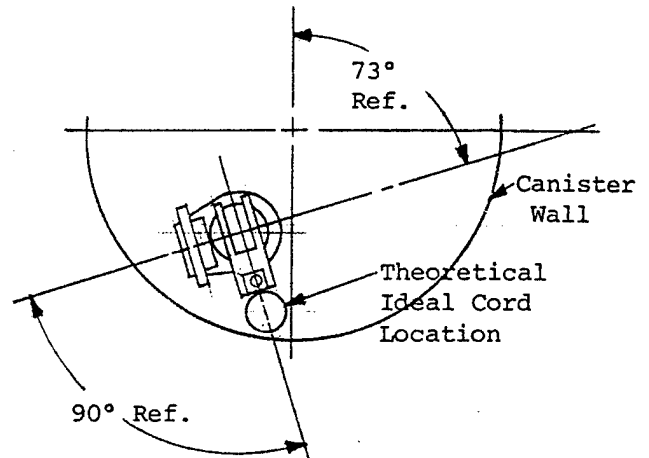

PROPOSED DESIGN  
(New Assemblies)

Advantages:  
(1) Best cord location  
(2) Eliminates possible pinch of bag chute against canister wall.  
(3) Prevents uneven cocking of lanyard pin during removal due to action of spring loaded jack cover on shaft connecting pin to cam.

The rubber seal of the cover then contacts the threaded portion of the jack, rather than the nut of the moisture cover. Trimming .094 inch from the length of the threaded portion of the jack would correct this problem, but the jack would no longer be an off-the-shelf part. The alternative is to mount the jack with an .094 inch thick spacer between the jack shoulder and the antenna platform. However, the lanyard pin, 0.469 dimension, would have to be lengthened to 0.594 inches (.125 inch longer) to compensate for the addition of this spacer. (Note that the lanyard pin had been procured before it was found that the previously used jack was no longer available. The replacement jack was slightly different than the sample submitted to JMR for evaluation. That is why this was not resolved).

(3) Each side of the base of the .250 inch wide through slot on the release cam should have a .031 inch radius added to prevent stress concentration.

(4) Increasing the height of the tang (0.585 inch high) on the release plate would ensure easier setting of the timer mechanism. If the 30° feature (on Dwg. No. 640124) which controls this height in the part blank, were increased to 44°, the resulting finger pad tang would be 1.042 inch high.

(5) Burrs on the inside of the dropsonde housing created by tapping the six 8-32 inch holes should be removed before sonde assembly. The burrs tend to abrade the O-ring seal on the antenna platform when the O-ring passes by the holes during assembly. Possibly a looser fit for the O-ring should also be investigated, if such a looser fit would not

compromise the sealing properties.

(6) The Honeywell CAPS electronics package should be provided with a diode on the voltage supply line to eliminate damage from an accidentally reversed polarity.

(7) The hygistor will fit into its mounts better if the .550 inch height of the retainer spring center is reduced to .450 inch. Care must be taken that the left-and right-hand retainer springs are properly assembled, i.e., offset towards the base of the retainer spring center, to ensure proper hygistor orientation.

(8) A conductive gasket, such as a wire mesh O-ring, should be incorporated between the antenna and its housing to ensure 360° electrical contact, compensating for possible out-of-roundness conditions. The antenna should also be protectively plated to prevent oxidation.

#### FUTURE DROPSONDE STUDY RECOMMENDATIONS

(1) A study should be instituted to evaluate alternate timer mechanisms for the main parachute deployment in order to reduce cost and complexity and increase reliability.

(2) Early evaluation of the efficacy of the battery lanyard change on the chute deployment should be conducted.

(3) Reference B discusses the variation in elapsed time for main chute separation from its plastic bag. (There is no specification for this separation). Paragraph 5 of the discussion states in part "since the bag is a plastic material and is quite smooth, the bag should generally have no

difficulty in pulling away from the main chute, unless a packing problem had occurred." This statement disregards the well-known effect of static electricity cling demonstrated by polyethylene film bags, as well as the tendency for areas of partial vacuum to occur when the chute is rapidly removed from its bag. It is suggested that the bag should be made from an anti-static film and the addition of a pattern of perforations to the bag should be investigated to eliminate vacuum effects.

(4) Reference B also suggests an investigation of the strength of the drogue chute lines. JMR concurs with this recommendation.

#### CONCLUSIONS

The extensive laboratory and field testing conducted during the development and pre-production phases of the dropsonde program provided timely identification of potential failure modes, allowing design revisions and change incorporations, especially during the early stages of the program.

The 100 delivered pre-production dropsondes have been designed and tested to the extent that the risk of meeting all specification and functional performance requirements has been minimized.

The dropsonde has been so designed and configured that incorporation of future add-on capabilities, such as BT (bathythermograph) and wind-sensing, can be easily and economically incorporated.

Tooling drawings and documentation have been prepared such that additional identical follow-on production units can be economically and reliably produced.

REFERENCES

- A. NADC Report (No. 79194-30) by John Sniscak, DT-2 (Development Testing) Report for CY 1978 - "AN/AMT-22 Meteorological Dropsonde and RDSRU (Refractive Dropsonde Signal Recording Units) Processor Engineering Field Test Results", Dated 7 Dec 1979
- B. NADC Trip Report, AIRTASK A370370P/001C/OW0514CC00, AN/AMT-22 Dropsonde Flight Test at NAEC (Naval Air Engineering Center), Lakehurst, NJ, Dated 8 Feb 1980

ENCLOSURES

- (1) Excerpt from NADC Report, DT-2 (Development Testing), Dropsonde Design Modifications Recommended from Key West Test Results of Feb 1978
- (2) Excerpt from NADC Report, DT-2 (Development Testing), Dropsonde Design Modifications Recommended from Warren Grove Test Results of Jul 1978
- (3) Excerpt from NADC Report, DT-2 (Development Testing), Timer Mechanism Design Modifications Recommended from Lakehurst Test Results of Sept 1978

ENCLOSURE 1

RE: DROPSONDE DESIGN MODIFICATIONS RECOMMENDED FROM KEY WEST TEST RESULTS

TIMER MECHANISM

1. Machined parts. All sharp edges were removed from machined parts in timer mechanism.
2. Grommets placed in slots that nylon rope passes through.
3. Redesigned release latch lock spring to allow more positive lock.
4. Sear redesigned, positively coupled to timer.
5. Knot tied in main cord to anchor drogue parachute attachment at centerpoint of line.
6. Government specification 500# test nylon parachute cord utilized in place of conventional type 500# test cord.
7. Spring (airstream release) was replaced with a heavier spring.

CANNISTER HOUSING

Criss-crossed wax nylon cord attached to end of dropsonde above sensors.

ANTENNA HOUSING

1. Edges of fiberglass antenna housing were rounded to prevent the possibility of parachute line being severed.
2. 1/2 in. water drain holes placed around base diameter of antenna housing.
3. Antenna design changed by NADC revision (1).

ENCLOSURE 1 (cont'd)

ANTENNA PLATFORM

1. Battery plug moisture cover installed. Cam on battery plug redesigned to work w/moisture cover.

2. O-ring seal placed around antenna platform for seal between it and housing cannister.

INSTRUMENT PACKAGE

1. 50% duty cycle incorporated in transmitter.

2. Hygistor mount changed to allow easier installation without distortion.

3. Thermistor mount changed to tubelets with accessible solder points to allow replacement in field.

4. Recess sensor mount 1 inch further into sonde tube.

SAFETY COVER

Design changed to allow easier removal.

ENCLOSURE 2

RE: DROPSONDE DESIGN MODIFICATIONS RECOMMENDED FROM WARREN GROVE  
TEST RESULTS

TIMER MECHANISM

1. Timer - removed raised section of timer cam by stoning to insure smooth operation of timer.
2. Timer - place flat washer under each leg of standoffs to insure stability in baseplate holes, also to increase tolerance between baseplate and timer cam lever pin.
3. Release Plate - removed all rough edges and burrs in notched area.
4. Sear - elongate existing hole, such that it prevents any main spring pressure, transmitting through to time cam pin. Remove all burrs.
5. Nylon Cord - tie knot in main line on bottom of timer to allow more space for drogue chute and a more positive attachment should line be severed.
6. The use of square knot and a half hitch for more secure joining of two ends of lines.
7. Battery Plug Line - will be tied off to drogue chute and through drogue chute restraining knot in main timer line, in the event of drogue chute separation, battery would be energized by escapement of timer unit.
8. Drogue Chute - a grommet will be placed in loops at attachment point of drogue chute with main timer line being passed through grommet, to cushion shock of Q-force and increase radius of curve around timer line.

ENCLOSURE 3

RE: TIMER MECHANISM DESIGN MODIFICATIONS RECOMMENDED FROM LAKEHURST  
TEST RESULTS

- a. Release latch fingers extended vertically approximately 1/4 inch. This provides a stop if all dogs are not locked in place.
- b. Cover plate slots shape will be changed to allow conformal fit with grommets (to reduce fraying of 500 lb test line).
- c. Timer set indicator redesigned for more stable attachment.
- d. Flat head screw utilized in top plate to secure latch spring stud in place of present round head.
- e. Rivets in place of flat head screws to secure wing to cover plate.
- f. Sear mount raised and sear tip lengthened (to prevent premature release of timer mechanism).

DISTRIBUTION LIST

Copy to:

OP-952

NAVAIR (AIR-370P, T. Czuba; PMA-264, J. Keane; AIR-54901, G. Pereseghin)

COMNAVOCEANCOM, Code N45, Bay St. Louis, MS, ATTN: W. Highlands

COMDF

GF

304 DF (2)

3044 (2)

30 DF (2)

1P1

1S1

40F

6013

Gentex Corporation, P. O. Box 315, Carbondale, PA 18407

ATTN: W. Harvey Jagoe and Kenneth Smith

Honeywell, Inc. 600 Second Street North, Hopkins, MN 55343

ATTN: C. Motchenbacher

Royal Signals Radar Establishment, Room G802, Great Malvern, WORC, England

ATTN: Dr. John Clarke

Sa1 Picard, Code 02A, CTF-66, FPO NY 09521

CDR D. L. Freeman, Box 72, FPO NY 09510

Lt. Jim Etro, NAVOCEANCOMDET, Sigonella, Italy, FPO NY 09523