

AL/EQ-TR-1996-0052

**UNITED STATES AIR FORCE  
ARMSTRONG LABORATORY**

---

**Characterization and Optimization of  
Dual Anaerobic/Aerobic Biofilm  
Process**

A. Paul Tonga, Thomas DiStefano, Martha Arkins, Karrie  
Dudiak, and Robert J. Steffan

**ENVIROGEN, INC.**  
Princeton Research Center  
410 Quakerbridge Road  
Lawrenceville, New Jersey, 32404-5323

April 1997

19971215 054

**DTIC QUALITY INSPECTED 3**

*Approved for public release; distribution is unlimited.*

**Environics Directorate  
Environmental Risk Management  
Division  
139 Barnes Drive  
Tyndall Air Force Base FL  
32403-5323**

## NOTICES

This report was prepared as an account of work sponsored by an agency of the United States Government. Neither the United States Government nor any agency thereof, nor any employees, nor any of their contractors, subcontractors, or their employees, make any warranty, expressed or implied, or assume any legal liability or responsibility for the accuracy, completeness, or usefulness of any privately owned rights. Reference herein to any specific commercial products, process, or service by trade name, trademark, manufacturer, or otherwise, does not necessarily constitute or imply its endorsement, recommendation, or favoring by the United States Government or any agency, contractor, or subcontractor thereof. The views and opinions of the authors expressed herein do not necessarily state or reflect those of the United States Government or any agency, contractor, or subcontractor thereof.

When Government drawings, specifications, or other data are used for any purpose other than in connection with a definitely Government-related procurement, the United States Government incurs no responsibility or any obligation whatsoever. The fact that the Government may have formulated or in any way supplied the said drawings, specifications, or other data, is not to be regarded by implication, or otherwise in any manner construed, as licensing the holder or any other person or corporation; or as conveying any rights or permission to manufacture, use, or sell any patented invention that may in any way be related thereto.

This technical report has been reviewed by the Public Affairs Office (PA) and is releasable to the National Technical Information Service (NTIS) where it will be available to the general public, including foreign nationals.

This report has been reviewed and is approved for publication.

FOR THE COMMANDER:

  
ALISON THOMAS  
Project Officer

  
ALLAN M. WEINER, Lt Col, USAF  
Chief, Environmental Risk Management Division

REPORT DOCUMENTATION PAGE			Form Approved OMB No. 0704-0188	
Public reporting burden for this collection of information is estimated to average 1 hour per response, including the time for reviewing instructions, searching existing data sources, gathering and maintaining the data needed, and completing and reviewing the collection of information. Send comments regarding this burden estimate or any other aspect of this collection of information, including suggestions for reducing this burden, to Washington Headquarters Services, Directorate for Information Operations and Reports, 1215 Jefferson Davis Highway, Suite 1204, Arlington, VA 22202-4302, and to the Office of Management and Budget, Paperwork Reduction Project (0704-0188), Washington, DC 20503.				
1. AGENCY USE ONLY (Leave blank)	2. REPORT DATE 30 January 1997	3. REPORT TYPE AND DATES COVERED Final Report (3 Oct 95 - 2 Oct 96)		
4. TITLE AND SUBTITLE Characterization and Optimization of Dual Anaerobic/Aerobic Biofilm Process			5. FUNDING NUMBERS C:F41624-95-C-4000	
6. AUTHOR(S) A. Paul Togna, Ph.D.; Thomas D. DiStefano, Ph.D., P.E.; Martha Arkins, Karrie A. Dudiak; and Robert J. Steffan, Ph.D.				
7. PERFORMING ORGANIZATION NAME(S) AND ADDRESS(ES) Envirogen, Inc. Princeton Research Center 4100 Quakerbridge Road Lawrenceville NJ 08648			8. PERFORMING ORGANIZATION REPORT NUMBER  N/A	
9. SPONSORING/MONITORING AGENCY NAME(S) AND ADDRESS(ES) Armstrong Laboratory, Environics Directorate (AL/EQW) 139 Barnes Drive, Suite 2 Tyndall AFB FL 32404-5323			10. SPONSORING/MONITORING AGENCY REPORT NUMBER  AL/EQ-TR-1996-0052	
NOTE: AL/EQM POC is Ms Alison Thomas, (904) 283-6203.				
11. SUPPLEMENTARY NOTES Prepared in cooperation with Bucknell University, Envirogen's research institution subcontractor for this Phase I STTR. The authors also acknowledge Dr. Lily Young, Rutgers University, for her technical assistance.				
12a. DISTRIBUTION AVAILABILITY STATEMENT Authorized to US Government agencies only because of the proprietary nature of the research. Limitation applied January 1997 and will be in effect for five years. Other requests for this document must be referred to AL/EQPP, 139 Barnes Drive, Suite 2, Tyndall Air Force Base, Florida 32403-5323.			12b. DISTRIBUTION CODE  B	
13. ABSTRACT (Maximum 200 words) The purpose of this Phase I STTR effort was to develop and characterize a dual anaerobic/aerobic biofilm process that promotes anaerobic reductive dehalogenation and aerobic cometabolic biodegradation, simultaneously, in a single biological reactor. The project focused on establishing the proof-of-concept for the simultaneous anaerobic dechlorination of tetrachloroethylene (PCE) and cometabolic oxidation of trichloroethylene (TCE) within a single laboratory-scale fluidized bed bioreactor (FBR) operated under bulk aerobic conditions. Concomitant BTEX (benzene, toluene, ethylbenzene, and xylenes) removal was also demonstrated. The bioreactor was inoculated with anaerobic sludge and a culture of the bacterium Burkholderia cepacia G4, which degrades TCE in the presence of Toluene. Over the length of the project, approximately 90 and 80 percent of the PCE and TCE added to the system was degraded, respectively. BTEX removal efficiencies were consistently greater than 99 percent. No dichloroethene or vinyl chloride was detected in liquid or vapor effluent samples. The bioreactor contained anaerobes that could dechlorinate PCE during serum bottle experiments. The anaerobes could use methanol or hydrogen, but not toluene, as electron donors to reduce PCE. Biomass removed from the bioreactor was also capable of degrading TCE in serum bottles at rates comparable to those observed during operation of ENVIROGEN's field-pilot TCE bioreactors.				
14. SUBJECT TERMS Bioremediation, Anaerobic/aerobic treatment, Trichloroethylene, Tetrachloroethylene, Chlorinated volatile organic chemicals, Fluidized-bed bioreactor, Groundwater			15. NUMBER OF PAGES 64	
			16. PRICE CODE	
17. SECURITY CLASSIFICATION OF REPORT UNCLASSIFIED	18. SECURITY CLASSIFICATION OF THIS PAGE UNCLASSIFIED	19. SECURITY CLASSIFICATION OF ABSTRACT UNCLASSIFIED	20. LIMITATION OF ABSTRACT UL	

## PREFACE

This report summarizes research activities conducted by Envirogen, Inc. for Armstrong Laboratory, Environics Directorate at Tyndall AFB, FL through U.S Department of Defense Small Business Technology Transfer (STTR) contract no. F41624-95-C-4000 "Characterization and Optimization of Dual Anaerobic/Aerobic Biofilm Process" during the performance period October 3, 1995 through October 2, 1996.

The work summarized in this report have been conducted by A. Paul Togna and Robert J. Steffan of Envirogen and Thomas D. DiStefano of Bucknell University. The project officer was Alison Thomas of Armstrong Laboratory.

The address of the organization performing this work, and the technical contact is:

Envirogen, Inc.  
Princeton Research Center  
4100 Quakerbridge Road  
Lawrenceville, New Jersey 08648  
Contact: Paul Togna  
Telephone: (609) 936-9300

(The reverse of this page is blank)

## EXECUTIVE SUMMARY

### OBJECTIVE

The objective of this research was to develop and characterize a dual anaerobic/aerobic biofilm process that promotes anaerobic reductive dehalogenation and aerobic cometabolic degradation, simultaneously, in a single bioreactor. The project focused on establishing the proof-of-concept for the simultaneous anaerobic dechlorination of tetrachloroethylene (PCE) and cometabolic oxidation of trichloroethylene (TCE) within a laboratory-scale fluidized bed bioreactor (FBR). Concomitant BTEX (benzene, toluene, ethylbenzene, and xylene[s]) removal was also demonstrated. The FBR system was used as a model to advance the understanding of the dual anaerobic/aerobic biofilm process for use in both *in situ* or above-ground applications.

### BACKGROUND

Currently used groundwater treatment technologies include above-ground (*ex situ*) "pump and treat" methods, both biological and physical/chemical, and *in situ* biodegradation. For situations where groundwater is pumped to the surface, chlorinated volatile organic chemicals (VOCs) are often removed by air stripping and/or adsorption onto activated carbon. However, unless the VOCs are trapped and recovered, or destroyed, air stripping releases the VOCs into the atmosphere, creating another source of environmental pollution, while activated carbon adsorption merely transfers the VOCs from a liquid to a solid phase, which then requires subsequent treatment or disposal.

Biodegradation processes have several distinct advantages over other remediation methods. Most importantly, biodegradation processes facilitate the complete destruction of toxic materials. In addition, the total life cycle cost (which includes capital, operating, and maintenance costs) for biological processes are often significantly less than competitive physical/chemical technologies.

Biological treatment of chlorinated VOCs often requires both anaerobic and aerobic environments. For example, PCE cannot be biodegraded under aerobic conditions, while TCE can be biodegraded in both aerobic and anaerobic environments. Biological destruction of TCE under aerobic conditions requires the presence of a co-substrate that acts both as a food source and an inducer to maintain enzymatic activity.

One of the most frequently used *ex situ* biological groundwater treatment technologies is the fluidized bed bioreactor (FBR). FBRs are highly efficient fixed-film bioreactors that rely on the immobilization of microbes on a hydraulically fluidized bed of media particles. The use of

granular activated carbon (GAC) as the fluidized bed media provides a means of integrating the removal mechanisms of biotreatment and physical/chemical adsorption, enhancing the ability of the system to overcome issues of microbial inhibition due to toxic inputs and treatment of recalcitrant compounds. The use of GAC also aids in treating fluctuating and changing loads which are often encountered during groundwater applications. Oxygen is supplied by a bubbleless aeration device, eliminating undesirable emissions of volatile organic chemicals from the bioreactor.

Since the FBR is a fixed-film process, it is likely that anaerobic zones are created within the interior regions of these biofilms, creating areas where sulfate-reducing microorganisms and methanogens can survive. Therefore, under bulk aerobic operation, anaerobic dechlorination may occur within FBRs in the interior "pockets" of the GAC support where oxygen is depleted. Under these conditions, aerobic FBRs could be used to treat more recalcitrant chlorinated contaminants, such as PCE, along with more easily degradable contaminants that can be used as growth substrates.

Using the above information as a starting point, the objective of this research was to develop and characterize a dual anaerobic/aerobic biofilm process that promotes anaerobic reductive dehalogenation and aerobic cometabolic degradation, simultaneously, in a single bioreactor. Development of a dual anaerobic/aerobic bioreactor process could expand the range of sites amenable to bioremediation technologies.

## SCOPE

The major goals of the research project were to: (1) identify critical parameters which support stable degradative activity within an aerobic FBR system; (2) confirm that both anaerobic dehalogenation and aerobic cometabolic degradative activities were occurring simultaneously; and (3) characterize the microbial population in the bioreactor. The goals were broken down into six basic tasks:

1. operate and characterize a laboratory-scale FBR system operated under bulk aerobic conditions fed a mixture of TCE, PCE, and BTEX (benzene, toluene, ethylbenzene, and xylenes);
2. confirm aerobic cometabolic degradation of TCE using bottle assays;
3. confirm anaerobic dechlorination of PCE using bottle assays and identify metabolic products of dechlorination;
4. examine toluene as an electron donor for reduction of PCE;
5. determine the fate of PCE in the biofilm reactor using [ $^{14}\text{C}$ ]PCE; and

6. characterize the anaerobic and aerobic degradative bacteria.

## RESULTS

### *FBR Performance*

**Operating Conditions.** The FBR system was first inoculated with anaerobic sludge from a local wastewater treatment plant, and then with the TCE-degrading bacterium *Burkholderia cepacia* G4. *B. cepacia* G4 will cometabolically oxidize TCE using toluene as a co-substrate. The performance of the FBR was monitored using an on-line gas chromatograph (GC) equipped with a purge-and-trap system. Over the first month of operation, influent PCE and TCE concentrations were generally maintained between 2,000 and 8,000 ppb, and the (toluene)/(TCE+PCE) ratio was maintained at approximately 1. After one month of operation, the (toluene)/(TCE+PCE) ratio was increased to 10. Over the second month of operation, influent PCE and TCE concentrations were reduced to between 100 to 1,000 ppb due to mechanical feed problems. For the third and last month of operation, influent PCE and TCE concentrations were generally stable between 1,000 and 2,000 ppb. The average O<sub>2</sub> consumption rate over the experiment was approximately 0.65 mg per minute.

**Performance Based on Influent and Effluent GC Measurements.** During the operation of the FBR system, the effluent quality remained high. BTEX removal efficiencies were consistently greater than 99 percent, and PCE effluent concentrations were between 40 and 180 ppb, regardless of influent PCE levels. The PCE removal efficiency during the third month of operation was approximately 90 percent, when the influent PCE concentration was steady at approximately 1,200 ppb. In the case of TCE, effluent concentrations increased over the first month of operation, corresponding to an increase in influent TCE concentrations. After the first month, consistent TCE effluent quality between 350 and 450 ppb was observed regardless of influent TCE concentrations. The TCE removal efficiency during the third month of operation was approximately 83 percent when the influent TCE concentration was steady at approximately 2,600 ppb.

**Dechlorination Products.** No vinyl chloride (VC) or dichloroethylene (DCE) was detected in liquid grab samples analyzed via Method 8260 (gas chromatography/mass spectroscopy purge-and-trap). The fact that VC and DCE were not detected in the bioreactor effluent indicates no build-up of PCE dechlorination products, and provides support for aerobic cometabolic activity. Intermediate products of PCE dechlorination (VC, DCE, ethene, or ethane) were also not detected in the bioreactor headspace, although low levels of methane (30 to 40 µg/L) were detected.

**Overall Mass Balance.** At the completion of the project, a sample of the GAC within the system was withdrawn and extracted with methanol for analysis of adsorbed TCE and PCE, and estimates of the mass of TCE and PCE adsorbed to the GAC were obtained. Estimates of the total mass of TCE and PCE added to the system in the influent feed stream, and removed from the system in the liquid effluent, were obtained by integrating the areas under the influent and effluent concentration versus time curves. Finally, an estimate of the TCE and PCE discharged from the system in the vapor phase was determined by multiplying the average TCE and PCE concentrations detected in the bioreactor headspace by the estimated vapor discharge rate. Based on these results, approximately 80 and 90 percent of the TCE and PCE added to the system during the experiment was degraded, respectively.

#### *Aerobic TCE Bottle Assays*

After 3 weeks of operation, samples of the GAC support material were removed from the FBR through side ports in the bioreactor column. Biomass was removed from the GAC support by vigorously shaking the material, and standard TCE bottle assays were performed. The specific TCE degradation rate of the biomass was 0.04 to 0.08 nmoles per minute per mg of total protein (nmoles/minute•mg), comparable to rates observed during long-term operation of ENVIROGEN's TCE Gas-phase Bioreactor (GPR) utilizing *Burkholderia cepacia* G4 and phenol as a co-substrate for treatment of TCE in air. The specific TCE degradation rate observed for the biomass within the FBR was between 2 and 7 percent of the specific TCE degradation rate of the pure *B. cepacia* G4 strain used to inoculate the system (1.2 nmoles/minute•mg), which is also typical of previous field results.

#### *Anaerobic PCE Bottle Assays*

After 3 weeks of operation, samples of the GAC support material were removed from the FBR under anaerobic conditions through side ports in the bioreactor column. Anaerobic bottle assays were conducted on these samples to investigate PCE dechlorinating activity. Biomass was removed from the GAC support by vigorously shaking the material. With no GAC in the bottles, measured products of PCE dechlorination represented 94 to 103 percent of the cumulative PCE added. PCE dechlorination was observed when either methanol or hydrogen was used as an electron donor. However, toluene would not serve as an electron donor for the culture. With time, vinyl chloride represented the major product of dechlorination; TCE was not detected and insignificant quantities of DCE were measured.

An electron balance was performed when hydrogen was used as an electron donor. The electron balance showed that hydrogen was used completely, and that methane production accounted for approximately 75 percent of the hydrogen use. Due to the excess of reducing equivalents provided, PCE dechlorination accounted for only a minor fraction of hydrogen use after a 2-day incubation period. Acetate was not detected in the samples.

### *Bioreactor $^{14}\text{C}$ [PCE] Experiments*

After approximately 100 days of continuous flow-through operation, the FBR system was operated in recycle mode, and TCE was removed from the feed. An aqueous solution containing  $^{14}\text{C}$ [PCE] and BTEX was then injected into the bioreactor using a syringe over a 3-day period. Three fractions were then collected for  $^{14}\text{C}$  analysis: (1) solids; (2) liquid; and (3) vapor. The solids fraction was comprised of a GAC sample taken directly from the reactor, which included attached biomass, and was analyzed for methanol-extractable radiolabeled organics. The liquid fraction was taken directly from the reactor, and was separately analyzed for total radiolabeled carbon, radiolabeled  $^{14}\text{CO}_2$ , and radiolabeled volatiles (compounds that could be stripped by air-sparging). The vapor fraction was comprised of gas headspace collected in a Tedlar<sup>®</sup> bag over the recirculation period, and was separately analyzed for radiolabeled  $^{14}\text{CO}_2$  and radiolabeled volatiles.

A total of  $2.2 \times 10^8$  dpm of  $^{14}\text{C}$ [PCE] was added to the FBR system during the experiment, based on a value of 100  $\mu\text{Ci}$  from the manufacturer's specifications and a theoretical dpm/ $\mu\text{Ci}$  ratio of  $2.2 \times 10^6$  for  $^{14}\text{C}$ . Using this value, only 4 percent of the initial radiolabeled carbon added to the system was recovered, and therefore, no conclusions can be made concerning the fate of PCE in the bioreactor. The experiment should be repeated. Of the total radiolabeled  $^{14}\text{C}$  recovered, 39% was found in the liquid phase, 56% was extracted from the GAC, and 5% was found in the vapor headspace. Over 99 percent of the radiolabel found in the vapor headspace was in the form of  $^{14}\text{CO}_2$ , and 12 percent of the total recovered radiolabel was in the form of  $^{14}\text{CO}_2$  (vapor plus liquid). The majority (82%) of the radiolabel found in the liquid phase was not volatile.

### *Culture Characterization*

After 4 months of operation, samples of GAC were removed from the bioreactor to characterize the aerobic microbial population in the system. The carbon samples were shaken vigorously, and the suspended liquid was serially diluted. The dilutions were spread on agar petri plates, which were incubated in the presence of toluene vapors. Five individual colonies

from a total of five plates were selected for growth in shake flasks. After growth was observed, bottle assays for TCE degradation were performed on the cultures. Three of the five colonies tested were capable of degrading TCE at rates comparable to pure *B. cepacia* G4.

The characteristics of the anaerobic culture isolated from the FBR were investigated by determining the culture's ability to grow under sulfate-, nitrate-, and iron-reducing conditions in serum bottles. The experiments were conducted using the anaerobic culture previously isolated from the bioreactor. This anaerobic culture was grown using methanol initially, and then hydrogen, as the electron donor for PCE dechlorination. Acetate was provided as the electron donor and carbon source for the anaerobic culture characterization experiments. Within the nitrate-reducing set of bottles, complete nitrate disappearance was observed in the three experimental bottles, along with the appearance of a small amount of nitrite. Nitrate disappearance was also observed in the "killed" and background controls, but the loss of nitrate in the experimental bottles exceeded the loss in the control bottles by 23 percent, and nitrite formation was minimal for the "killed" and background controls. No activity was observed for the sulfate-reducing or the iron-reducing sets of bottles. PCE dechlorinating activity was not tested under denitrifying, sulfate-reducing, or iron-reducing conditions during the anaerobic characterization experiments.

## CONCLUSIONS

The results of the project provide strong support for establishment of a dual anaerobic/aerobic biofilm process within the laboratory-scale FBR. Biomass removed from the system showed both reductive dehalogenation activity under anaerobic conditions, and oxidative cometabolic activity under aerobic conditions. A culture obtained from the GAC within the bioreactor contained anaerobes capable of dechlorinating PCE during serum bottle experiments. The anaerobic culture could use methanol or hydrogen as electron donors to reduce PCE. However, toluene would not serve as an electron donor. Methanogenesis was the major activity of the anaerobic culture; during bottle assay experiments, methane production accounted for 75 percent of hydrogen use. Additional bottle assay experiments suggested the presence of a denitrifying population as well. Under aerobic conditions, biomass removed from the GAC cometabolically degraded TCE using toluene as a co-substrate. The specific TCE degradation rate was comparable to rates observed during long-term operation of ENVIROGEN's TCE Gas-phase Bioreactor (GPR) utilizing *B. cepacia* G4 and phenol as a co-substrate. At the end of the project, three of five individual colonies from the bioreactor that were isolated on toluene-agar plates degraded TCE at rates comparable to pure *B. cepacia* G4. Finally, no dichloroethene,

vinyl chloride, ethene, or ethane were detected in effluent liquid or vapor headspace grab samples from the FBR, providing further support for aerobic cometabolic activity in the bioreactor.

Based on overall PCE and TCE mass balance calculations, taking into consideration adsorption onto the GAC and volatile losses, approximately 90 and 80 percent of the PCE and TCE added to the system was degraded, respectively. These mass balance calculations are conservative, however. In performing the mass balance calculations, the on-line GC data were used. However, analyses of influent and effluent liquid grab samples using SW-846 Method 8260 consistently produced higher influent and lower effluent concentrations than were observed using the on-line GC. Part of the reason for the large discrepancy between the on-line and grab sample measurements may be the wide range of concentrations measured using the on-line GC. If the mass balance calculations are adjusted using the grab sample data rather than the on-line data, the overall percentage of PCE and TCE degraded by the FBR increase to 98 and 95 percent, respectively.

No firm conclusions can be made concerning the fate of PCE in the bioreactor based on the radiolabeled  $^{14}\text{C}$ [PCE] experiments, since only 4 percent of the initial radiolabeled carbon added to the system was recovered. The experiments should be repeated.

## RECOMMENDATIONS

Based on the successful results of this project, the dual anaerobic/aerobic process should be further developed and tested for treatment of contaminated groundwater. The process is unique in that anaerobic reductive dehalogenation and aerobic biodegradation (both metabolic and cometabolic) occur simultaneously in a single system. Based on the project results, the process is well suited for initial development within a fluidized bed bioreactor (FBR) system.

In order to further optimize the FBR process, a deeper understanding of the factors affecting the observed anaerobic/aerobic biological activity is required, and the process must be tested in the field under non-ideal conditions. The information obtained during the field-pilot evaluation should be used to develop cost estimates for using above-ground dual anaerobic/aerobic processes for "pump and treat" applications. Bioreactor performance limitations should be established for treatment of other chlorinated target compounds of interest to the Air Force, such as trichloroethane and chloroform, if the site chosen for the field-pilot test is contaminated with these compounds. In addition, alternative primary substrates for cometabolism should be evaluated, since BTEX contamination may not be present at all sites. Finally, electron donor type and utilization should be optimized, and temperature and shock loading effects should be assessed.

(The reverse of this page is blank)

## TABLE OF CONTENTS

I. INTRODUCTION .....	1
A. OBJECTIVE .....	1
B. BACKGROUND .....	1
1. Biodegradation of Chlorinated Solvents .....	2
2. The Dual Anaerobic/Aerobic Process .....	4
C. SCOPE .....	6
II. METHODOLOGY .....	7
A. CHEMICALS AND STOCK SOLUTIONS .....	7
1. Reactor System .....	7
2. Aerobic Bottle Assays .....	7
3. Anaerobic Bottle Assays .....	7
B. BACTERIAL CULTURES AND PROCEDURES .....	8
1. Aerobic Inoculum .....	8
2. Anaerobic Inoculum .....	8
3. Aerobic Cultures .....	9
4. Anaerobic Cultures .....	9
C. ANALYTICAL PROCEDURES .....	10
1. Bioreactor Analysis .....	10
2. Aerobic TCE Bottle Assays .....	11
3. Anaerobic Studies .....	12
4. <sup>14</sup> C[PCE] Experiments .....	13
D. CONTINUOUS BIOREACTOR OPERATIONS .....	15
III. RESULTS .....	17
A. FBR PERFORMANCE .....	17
1. Abiotic Control Experiments .....	17
2. GAC Loading .....	17
3. Inoculation and Start-up .....	18
4. Continuous Operation .....	18
5. TCE and PCE Mass Balances .....	23
B. AEROBIC CULTURE PERFORMANCE .....	26
C. ANAEROBIC CULTURE PERFORMANCE .....	27
1. Cultures with Activated Carbon .....	27
2. First Generation Cultures without Activated Carbon .....	29
3. Second Generation Cultures .....	31

D. THE FATE OF PCE WITHIN THE FBR - $^{14}\text{C}$ [PCE] EXPERIMENTS.....	32
E. CULTURE CHARACTERIZATION.....	34
1. Aerobic Culture .....	34
2. Anaerobic Culture.....	36
IV. CONCLUSIONS .....	38
V. RECOMMENDATIONS.....	40
REFERENCES .....	41

## LIST OF FIGURES

1. ENVIROGEN FBR System Process Schematic .....	5
2. Laboratory-scale Dual Anaerobic/Aerobic FBR System Schematic .....	16
3. Abiotic Loss of Contaminants from the Laboratory-scale FBR System.....	20
4. GAC Adsorption Isotherms for TCE and PCE at Room Temperature Using the FBR Feed Mixture .....	21
5. Influent and Effluent PCE Concentrations During Operation of the Laboratory-scale FBR System .....	21
6. Influent and Effluent TCE Concentrations During Operation of the Laboratory-scale FBR System .....	22
7. Effluent PCE Concentrations During Operation of the Laboratory-scale FBR System .....	22
8. Effluent TCE Concentrations During Operation of the Laboratory-scale FBR System .....	23
9. TCE Bottle Assay Results.....	27
10. Evidence of Reductive Dechlorination.....	28
11. Chlorinated Ethenes Mass Balance.....	30
12. PCE and Toluene Concentrations in a Second-generation Bottle .....	32
13. TCE Bottle Assay for a Pure Culture Isolated from the FBR.....	35

(The reverse of this page is blank)

## LIST OF TABLES

1. Results of TCE and PCE Mass Balances.....	24
2. A Comparison of Measured and Predicted Carbon Adsorption at the End of the Experiment .....	25
3. A Comparison of Influent Grab Sample and On-line GC Measurements .....	25
4. A Comparison of Effluent Grab Sample and On-line GC Measurements.....	26
5. Electron Balance for a Hydrogen-fed Bottle.....	31
6. Results of Radiolabeled $^{14}\text{C}$ [PCE] Experiments .....	34
7. TCE Assays of Individual Colonies Isolated from the FBR After 14 Weeks.....	35

(The reverse of this page is blank)

## LIST OF ABBREVIATIONS

ABSM.....	anaerobic basal salts medium
AFB.....	Air Force base
BSM.....	basal salts medium
BTEX.....	benzene, toluene, ethylbenzene, and xylenes
DCE.....	dichloroethene
DOD.....	Department of Defense
DOE.....	Department of Energy
dpm.....	disintegrations per minute
ECD.....	electron capture detector
EFF.....	effluent
eq.....	equivalent
ETH.....	ethene
FBR.....	fluidized bed bioreactor
FID.....	flame ionization detector
GAC.....	granular activated carbon
GC.....	gas chromatograph
GC/MS.....	gas chromatography/mass spectroscopy
GPR.....	Gas-phase Bioreactor
HPLC.....	high performance liquid chromatography
HRT.....	hydraulic retention time
INF.....	influent
IRP.....	Installation Restoration Program
M.....	moles per liter
MLSS.....	mixed liquor suspended solids
mM.....	millimoles per liter
OD <sub>550</sub> .....	optical density at 550 nanometers
PCE.....	tetrachloroethylene
PID.....	photoionization detector
ppm.....	parts per million (by weight)
ppb.....	parts per billion (by weight)
RCRA.....	Resource Conservation and Recovery Act
SBIR.....	Small Business Innovative Research
STTR.....	Small Business Technology Transfer
TCD.....	thermal conductivity detector

TCE..... trichloroethylene  
VC..... vinyl chloride  
VOC..... volatile organic chemical

## I. INTRODUCTION

### A. OBJECTIVE

The objective of this research was to develop and characterize a dual anaerobic/aerobic biofilm process that promotes anaerobic reductive dehalogenation and aerobic cometabolic degradation, simultaneously, in a single bioreactor. This Phase I research project focused on establishing the proof-of-concept for the simultaneous anaerobic dechlorination of tetrachloroethylene (PCE) and cometabolic oxidation of trichloroethylene (TCE) within a laboratory-scale fluidized bed bioreactor (FBR). Concomitant BTEX (benzene, toluene, ethylbenzene, and xylenes) removal was also demonstrated. The FBR system was used as a model to advance the understanding of the dual anaerobic/aerobic biofilm process for use in both *in situ* or above-ground applications. The system was operated under defined conditions, allowing for the methodical characterization of degradative activities and initial optimization of critical process parameters.

### B. BACKGROUND

A number of low molecular weight, halogenated aliphatic compounds have found widespread use as organic solvents, degreasers, and cleaning agents. The potential environmental impact associated with chlorinated organics such as PCE and TCE was not appreciated in the past, and improper storage and disposal of these compounds has caused widespread contamination of soil and groundwater. The Department of Defense (DOD), through the Installation Restoration Program (IRP), has identified a number of sites at military installations where groundwater contains a variety of organic contaminants, including both chlorinated and nonchlorinated organics, at concentrations exceeding federally allowed drinking water standards. The DOD is committed to controlling the migration of hazardous substances from these identified sites, and thus preventing further environmental contamination. In addition, land and water releases of these chemicals by industrial facilities are federally regulated, and many previously contaminated sites require remediation under Superfund and Resource Conservation and Recovery Act (RCRA) legislation.

Currently used groundwater treatment technologies include above-ground (*ex situ*) "pump and treat" methods, both biological and physical/chemical, and *in situ* biodegradation. For situations where groundwater is pumped to the surface, chlorinated volatile organic chemicals (VOCs) are often removed by air stripping and/or adsorption onto activated carbon. However, unless the VOCs are trapped and recovered, or destroyed, air stripping releases the VOCs into the

atmosphere, creating another source of environmental pollution, while activated carbon adsorption merely transfers the VOCs from a liquid to a solid phase, which then requires subsequent treatment or disposal.

Biodegradation processes have several distinct advantages over other remediation methods. Most important, biodegradation processes facilitate the complete destruction of toxic materials. Thus, long-term material storage and monitoring can be greatly minimized. Additionally, ancillary pollution problems such as disposal of spent activated carbon, as well as secondary human exposure concerns, are essentially eliminated, further reducing the long-term economic burden imposed by hazardous materials. Finally, the total life cycle cost (which includes capital, operating, and maintenance costs) for biological processes are often significantly less than competitive physical/chemical technologies.

Treatment of chlorinated VOCs often requires both anaerobic and aerobic environments. For example, PCE cannot be biodegraded under aerobic conditions, while TCE can be biodegraded in both aerobic and anaerobic environments. Both anaerobic and aerobic approaches have been implemented for *in situ* bioremediation of chlorinated VOCs, though not concurrently. Each approach can be effective, but implementation and optimization is sometimes difficult due to the heterogeneous nature of the subsurface. In fact, some subsurface environments are not conducive to *in situ* remediation approaches. In these instances, "pump and treat" methods must be employed. In addition, "pump and treat" methods are effective at reducing plume migration, and can be used in conjunction with *in situ* bioremediation techniques. A broad spectrum of bioremediation technologies is therefore needed to meet the challenges of cleaning our environment, including above-ground bioreactor-based technologies.

### 1. *Biodegradation of Chlorinated Solvents*

TCE and PCE have been used extensively as solvent and degreasing agents. TCE is one of the most prevalent organic contaminants found in both soils and groundwater. Environmental problems with TCE and PCE are aggravated by their relatively high water solubility (1,100 ppm at 25°C), resulting in frequent drinking water contamination problems. Studies indicate that TCE may be directly carcinogenic (Miller & Guengerich, 1983). In addition, anaerobic biotransformation of TCE and PCE has been shown to result in the formation of vinyl chloride (VC), a potent carcinogen (Vogel and McCarty, 1985). Because many subsurface regions are anoxic, a significant potential exists for the accumulation of biologically formed vinyl chloride from TCE and PCE, with serious potential for adverse environmental and human health consequences. The Safe Drinking Water Act Amendment of 1986 reflects the concern over TCE by limiting its concentration in drinking water to 5 parts per billion (ppb) or less.

**Co-metabolic TCE Degradation.** Trichloroethylene (TCE), because of its recalcitrance and ubiquitous presence at contaminated sites, has become the model compound for studies of methods to remediate chlorinated organic contamination. Although many organisms that degrade TCE have been identified (Ensley, 1991), no known organism is capable of using TCE as a sole source of carbon and energy. Aerobic biological attack is cometabolic. Thus, biological destruction of TCE requires the presence of a co-substrate that acts both as a food source and an inducer to maintain enzymatic activity. TCE can be biodegraded by aerobic bacteria that oxidize toluene (Wackett & Gibson, 1988), phenol (Folsom et al., 1990), propylene (Ensign et al., 1992), isopropylbenzene (cumene) (Dabrock et al., 1992), isoprene (Ewers et al., 1990), methane (Fogel et al., 1986, Fox et al., 1990, Little et al., 1988, Oldenhuis et al., 1991), ammonia (Arciero et al., 1989), and propane (Wackett et al., 1989). All of these bacteria produce nonspecific oxygenases that utilize molecular oxygen ( $O_2$ ) and reducing energy [in the form of NAD(P)H] to oxidize both their growth substrate and TCE. Typically, the oxygenase enzyme systems are only produced by growth in the presence of the specific hydrocarbon (e.g., toluene-4-monooxygenase is induced by toluene).

**Reductive Dechlorination.** Many chlorinated compounds, including PCE, are recalcitrant to aerobic cometabolic degradation. As a general rule, increasing the number of chlorines on a carbon-based molecule renders it more difficult to degrade aerobically. The opposite is true under anaerobic conditions. Under anaerobic conditions, more-chlorinated compounds tend to be dechlorinated more rapidly than less-chlorinated compounds, possibly because they are in a more oxidized state due to the chlorine halogens. Thus, the order of chloroethene degradation under anaerobic conditions is PCE > TCE > DCE >> VC. Reductive dechlorination of vinyl chloride is usually the rate-limiting step for complete PCE and TCE dechlorination to ethene, and VC tends to accumulate in the environment. Similarly, higher-chlorinated benzene compounds such as pentachlorophenol tend to be more easily dechlorinated under anaerobic conditions than the lower chlorinated benzenes, such as chlorobenzene and most dichlorobenzenes.

**Related ENVIROGEN Experience.** Through internal (ENVIROGEN) as well as external funding from the Departments of Energy and Defense, ENVIROGEN has developed biological reactor-based treatment systems for the cometabolic destruction of TCE in air and water sources. Initially, research and development activities centered on gaining a thorough understanding of the biochemistry of TCE degradation, and selecting the most appropriate degradative organisms to catalyze the reaction. The development program continued through the construction of a novel suspended growth laboratory-scale gas-phase bioreactor (GPR) for air treatment. Greater than 90 percent TCE removal has been demonstrated using this suspended growth design when treating a TCE/benzene stream (Folsom, 1993), when treating a waste

stream containing mixed chlorinated solvents (Folsom, Kurisko, and Ensley, 1994), and when treating a pure TCE waste stream at concentrations up to 10 mg/L of TCE in the vapor phase (Ensley, 1992; Ensley and Kurisko, 1994). Effective long-term performance for over 9 months, averaging over 90 percent TCE removal, has been demonstrated (Guarini and Folsom, 1996). After extensive testing of the laboratory-scale unit, ENVIROGEN engineered and constructed a 4,000 liter pilot-scale GPR. The GPR design and TCE treatment process has been effectively demonstrated at Robins AFB, GA, and at F.E. Warren AFB, WY using the 4,000 liter pilot-scale bioreactor (Guarini and Folsom, 1996; Radian International, 1996).

ENVIROGEN has also demonstrated effective biological treatment of TCE in the liquid phase using a fluidized bed bioreactor (FBR). This technology was demonstrated during a Phase II SBIR award (DOD contract FO8635-91-C-0198 [Phase II]). During the Phase II award, a complex mixture of chemicals was treated during a field demonstration at Robins AFB, GA. Based on an overall TCE mass balance, subtracting the TCE removed from the water due to adsorption onto the activated carbon support, the FBR biodegraded 84% of the TCE from over 210,000 gallons of contaminated groundwater (Guarini and Folsom, 1996). The FBR system also effectively removed >97% of the 1,2-dichlorobenzene and >95% of the BTEX.

## 2. *The Dual Anaerobic/Aerobic Process*

One of the most frequently used *ex situ* biological groundwater treatment technologies is the fluidized-bed bioreactor (FBR). FBR systems are designed to treat contaminated groundwater from groundwater "pump and treat" systems for aquifer and/or landfill leachate remediation, as well as end-of-pipe treatment at manufacturing facilities. FBRs are highly efficient fixed-film bioreactors that rely on the immobilization of microbes on a hydraulically fluidized bed of media particles (Figure 1). These particles provide a vast surface area for growth of biological films capable of degrading a wide range of organic chemicals. The use of granular activated carbon (GAC) as the fluidized-bed media provides a means of integrating the removal mechanisms of biotreatment and physical/chemical adsorption, enhancing the ability of the system to overcome issues of microbial inhibition due to toxic inputs and treatment of recalcitrant compounds. The use of GAC also aids in treating fluctuating and changing loads which are often encountered during groundwater applications. The reactor maintains high concentrations of biomass attached to the GAC, thereby providing high volumetric efficiency. The waste stream is applied in an upflow mode at a velocity sufficient to fluidize (expand) the bed of carbon particles. The upflow velocity is determined by the specific density and particle size of the medium, and the required bed expansion. Oxygen is supplied by a bubbleless aeration device, essentially eliminating undesirable emissions of VOCs from the bioreactor. Typical

operation results in 90 to 99+% destruction of targeted organic chemicals with the release of minimal amounts of suspended solids.

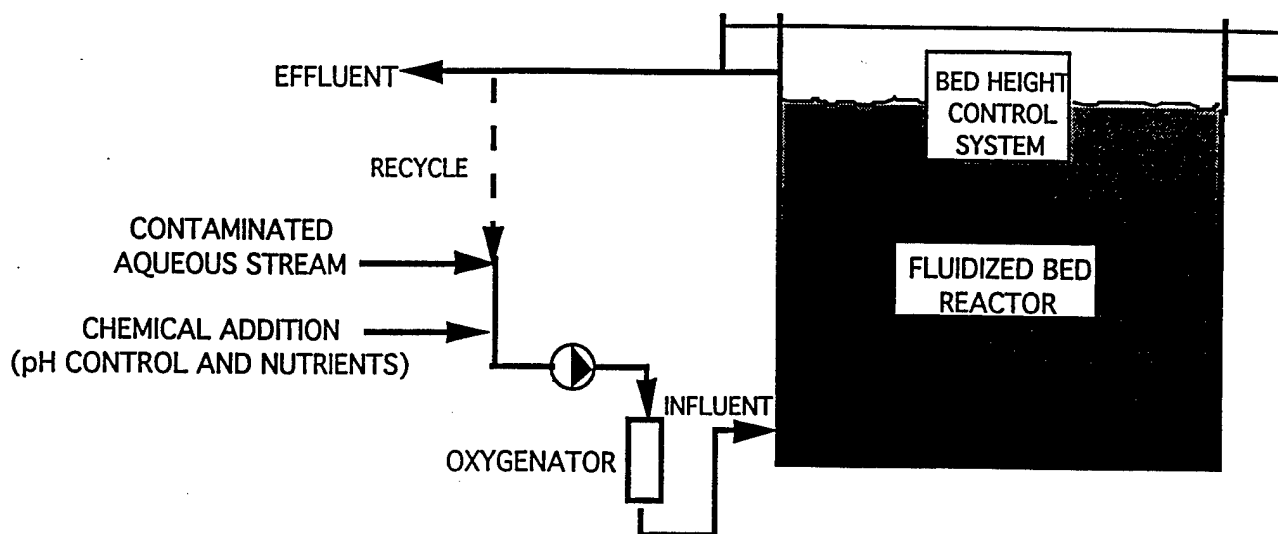

Figure 1. ENVIROGEN FBR System Process Schematic.

The types of contaminants that can be treated in FBR systems include petroleum hydrocarbons (Sutton and Mishra, 1994; Massol-Deya et al., 1995), aromatic compounds such as chlorobenzene (Klecka et al., 1994) and toluene (Shi et al., 1995), mixtures of aromatic compounds such as aniline and nitrobenzene (ENVIROGEN, unpublished results), a mixed maleic anhydride process waste stream (Brackin et al., 1996), chlorinated compounds such as methylene chloride (Sommerfield and Locheed, 1992), and recalcitrant compounds requiring co-substrates for aerobic biodegradation, such as TCE (Guarini and Folsom, 1996).

Since the FBR is a fixed-film process, it is likely that anaerobic zones may be created within the interior regions of these biofilms, creating areas where sulfate-reducing microorganisms and methanogens can survive (Arvin and Harremoes, 1990). This hypothesis is supported by the work of Enzien et al. (1994), who reported the reductive dechlorination of PCE and TCE under bulk aerobic conditions in a sediment column. The observed reductive dechlorination was attributed to microanaerobic communities in the aerobic sediment column, suggesting the potential for simultaneous aerobic and anaerobic biotransformation processes under bulk aerobic conditions. Methane production was also observed. PCE and TCE were

dechlorinated to DCE, and vinyl chloride was not detected. The results of Enzien et al. (1994) suggest that under bulk aerobic operation, anaerobic dechlorination can occur within FBRs in the interior "pockets" of the GAC support where oxygen is depleted. Under these conditions, aerobic FBRs can be used to treat more recalcitrant chlorinated contaminants such as PCE. Treatment of heavily chlorinated contaminants such as pentachlorophenol has been demonstrated under anoxic conditions using FBRs (Sutton and Mishra, 1994).

Using the above information as a starting point, the objective of this research was to develop and characterize a dual anaerobic/aerobic biofilm process that promotes anaerobic reductive dehalogenation and aerobic cometabolic degradation, simultaneously, in a single bioreactor. Development of a dual anaerobic/aerobic bioreactor process could expand the range of sites amenable to bioremediation technologies. A high performance, technically consistent, and low-cost anaerobic/aerobic biological treatment technology would be of great benefit to the Air Force during the remediation of contaminated groundwater at bases throughout the United States and the world, especially for sites contaminated with a broad range of compounds. A dual anaerobic/aerobic biofilm process offers the advantage of complete biodegradation in one system, thus reducing capital and operating costs.

### C. SCOPE

The overall objective of the Phase I effort was to characterize and optimize a dual anaerobic/aerobic biofilm process capable of destroying both PCE and TCE. The major goals of the Phase I project were to: (1) identify critical parameters which support stable degradative activity; (2) confirm that both anaerobic dehalogenation and aerobic cometabolic degradative activities were occurring simultaneously; and (3) characterize the microbial population. A laboratory-scale fluidized-bed bioreactor (FBR) was used for these studies. The Phase I goals were broken down into six basic tasks:

1. operate and characterize a laboratory-scale FBR system operated under bulk aerobic conditions fed a mixture of TCE, PCE, and BTEX;
2. confirm aerobic cometabolic degradation of TCE using bottle assays;
3. confirm anaerobic dechlorination of PCE using bottle assays and identify metabolic products of dechlorination;
4. examine toluene as an electron donor for reduction of PCE;
5. determine the fate of PCE in the biofilm reactor using [ $^{14}\text{C}$ ]PCE; and
6. characterize the anaerobic and aerobic degradative bacteria.

## II. METHODOLOGY

### A. CHEMICALS AND STOCK SOLUTIONS

#### 1. Reactor System

The PCE (Aldrich), TCE (J.T. Baker), benzene (J.T. Baker), toluene (Mallinckrodt), ethylbenzene (Aldrich), and *p*-xylene (Aldrich) used in the preparation of calibration standards and contaminant feed solutions were all of purity 99% or greater. The *o*- and *m*-xylene (Aldrich) were of purity 97% and 98%, respectively. The methanol (Baxter) used was of high-performance liquid chromatography (HPLC) grade.

A mixture of neat PCE, TCE, benzene, toluene, ethylbenzene, and *o*-, *m*-, and *p*-xylene was used as the contaminant feed to the system. The mixture was prepared in a ratio that provided the following initial approximate feed concentrations to the FBR: 5 ppm each of PCE and TCE (later changed to 1 ppm each); 3 ppm each of benzene and ethylbenzene; 10 ppm of toluene (later changed to 20 ppm); and 1.5 ppm each of *o*-, *m*-, and *p*-xylene.

#### 2. Aerobic Bottle Assays

The TCE used in degradation rate assays was obtained from J.T. Baker and was of 99.9% purity. A 40 mM TCE solution in HPLC grade methanol was used for the assays. The toluene used was obtained from Mallinckrodt and was of 99.8% purity. A 400 mM toluene solution in HPLC grade methanol was prepared for the assays.

The basal salts media (BSM) used in the assays consisted of (grams per liter water)  $\text{K}_2\text{HPO}_4 \cdot 3\text{H}_2\text{O}$  (4.25),  $\text{NaH}_2\text{PO}_4 \cdot \text{H}_2\text{O}$  (1.0),  $\text{NH}_4\text{Cl}$  (2.0). The trace metals solution added to the BSM contained nitrilotriacetic acid [NTA;  $\text{N}(\text{CH}_2\text{CO}_2\text{Na})_3 \cdot \text{H}_2\text{O}$ ] (0.12),  $\text{MgSO}_4 \cdot 7\text{H}_2\text{O}$  (0.2),  $\text{FeSO}_4 \cdot 7\text{H}_2\text{O}$  (0.012),  $\text{MnSO}_4 \cdot \text{H}_2\text{O}$  (0.003),  $\text{ZnSO}_4 \cdot 7\text{H}_2\text{O}$  (0.003), and  $\text{CoCl}_2 \cdot 6\text{H}_2\text{O}$  (0.001). The salts used to prepare the BSM were all reagent grade or higher.

#### 3. Anaerobic Bottle Assays

PCE, TCE, *trans*-1,2-DCE, and toluene were HPLC grade (99.9+%) obtained from Fisher Scientific. *cis*-1,2-DCE was obtained in neat liquid form (1-gram ampule from Supelco, Inc.). PCE and toluene were used as analytical standards and as culture substrates. The remaining chlorinated ethenes were used as analytical standards. HPLC grade methanol (99.9+%; Fisher Scientific) was also used as a culture substrate. Hydrogen (99.95+%; Keystone Airgas) was used

as a culture substrate and analytical standard. Vinyl chloride, ethene, and methane were obtained as gases in lecture bottles (99+% Keystone Airgas).

Initially, a mixture of neat PCE dissolved in methanol (0.2 mL PCE/3.3 mL methanol; 325 mg/2610 mg) was employed for routine feeding of methanol and PCE to the cultures. Later, cultures were fed PCE from a distilled water stock that was saturated with PCE. For some cultures, hydrogen was added as an electron donor instead of methanol. Some cultures were also fed a distilled water stock that was saturated with toluene. A yeast extract stock solution (50 g/L) was routinely added to the cultures. The yeast extract stock was added to a serum bottle and gassed with 70%N<sub>2</sub>/30%CO<sub>2</sub> via a cannula prior to application of a butyl rubber stopper and aluminum crimp cap.

## B. BACTERIAL CULTURES AND PROCEDURES

### 1. *Aerobic Inoculum*

The aerobic inoculum for the bioreactor was retrieved from a frozen (-80°C) stock of *Burkholderia cepacia* G4 in 10% methyl sulfoxide. Approximately 1 mL of culture was brought to room temperature and transferred to 100 mL of BSM containing 1 mM phenol (Mallinckrodt) and 10 mM lactate (Mallinckrodt). The culture was grown at 30°C until a turbidity (optical density) of approximately 2.0 was reached, as measured with a Spectronic 20 spectrophotometer (Milton Roy Co., Rochester, NY) at a wavelength of 550 nanometers (OD<sub>550</sub>). Phenol assays, as described in Folsom et al. (1990), were performed to confirm phenol consumption. Each time phenol was consumed, 10 µL of 88% liquid phenol (Mallinckrodt) was added to the flask, for a total of 3 feedings during incubation. All culture manipulations were performed under aseptic conditions.

### 2. *Anaerobic Inoculum*

The anaerobic inoculum for the FBR was mixed liquor suspended solids (MLSS) obtained from an anaerobic digester at a local wastewater treatment plant. This treatment plant processes both domestic and industrial waste. The bioreactor was purged with nitrogen at a rate of 5 mL per minute after inoculation for approximately 24 hours to maintain an anaerobic environment. Glucose was provided as a carbon and energy source for the inoculum. A glucose solution was fed to the reactor daily through a side port in the reactor. The solution was prepared to provide a daily concentration in the system of 0.012 M glucose. Methane production was monitored as an indication of inoculum viability.

### 3. *Aerobic Cultures*

Enrichments of the aerobic culture within the FBR were prepared from a sample of bioreactor liquid for the purpose of performing TCE degradation assays during aerobic culture characterization (Section III.E.1). Dilutions of the bioreactor sample were prepared and spread on BSM agar plates. The plates were incubated under a beaker with toluene vapors for 5 days at 30°C. After 5 days, colonies were transferred to shake flasks containing 100 mL of sterile BSM. Enrichment cultures were grown for 6 to 10 days in shake flasks on toluene vapors supplied from a glass bulb containing neat toluene suspended above the liquid medium.

### 4. *Anaerobic Cultures*

**Cultures with Activated Carbon.** Biomass from the reactor was sampled and transferred to serum bottles under anaerobic conditions according to the following procedure. Approximately 200 mL (activated carbon plus liquid) were drawn from sample taps in the reactor (100 mL from each of the top and bottom sample taps). Samples were dispensed into 70-mL (total volume) serum bottles that contained 25 mL of anaerobic basal salts medium. Each bottle was purged vigorously with nitrogen while approximately 25 mL of sample was dispensed. Six bottles were used to collect samples. Because of difficulty in dispensing equal volumes of biomass and activated carbon to each bottle, an anaerobic glove bag was employed to mix the contents of the bottles. In the glove bag, the six bottles were combined in a glass beaker. The contents of the beaker were mixed using a spin bar and magnetic mixer. 50 mL of the mixture was pipetted into each of the six 70-mL serum bottles. A Teflon<sup>®</sup>-lined butyl rubber septum and aluminum crimp seal was placed on each bottle prior to removal from the glove bag. Outside the glove bag, each bottle was purged for about 2 minutes with N<sub>2</sub>/CO<sub>2</sub> (70%/30%) to replace the N<sub>2</sub>/H<sub>2</sub> headspace from the anaerobic glove bag.

**Subculturing Procedures.** Anaerobic cultures were grown in an anaerobic basal salts medium (ABSM) with a modified composition from that of Zeikus (1977). The medium consisted of (grams per liter distilled water) NH<sub>4</sub>Cl (0.20), K<sub>2</sub>HPO<sub>4</sub>•3H<sub>2</sub>O (0.10), KH<sub>2</sub>PO<sub>4</sub> (0.055), MgCl<sub>2</sub>•6H<sub>2</sub>O (0.20), resazurin (0.001), FeCl<sub>2</sub>•4H<sub>2</sub>O (0.10), Na<sub>2</sub>S•9H<sub>2</sub>O (0.50), NaHCO<sub>3</sub> (6.0). A trace metals solution was added to the ABSM (10 mL per liter). The solution contained (grams per liter distilled water) MnCl<sub>2</sub>•4H<sub>2</sub>O (0.1), CoCl<sub>2</sub>•6H<sub>2</sub>O (0.17), ZnCl<sub>2</sub> (0.10) CaCl<sub>2</sub> (0.20), H<sub>3</sub>BO<sub>4</sub> (0.019), NiCl<sub>2</sub>•6H<sub>2</sub>O (0.05), Na<sub>2</sub>MoO<sub>4</sub>•2H<sub>2</sub>O (0.02).

Cultures were transferred to remove activated carbon, and then subcultured for other experiments. In preparation for the transfer, 40-mL aliquots of basal medium were anaerobically

transferred from a reservoir to 70-mL serum bottles via a calibrated peristaltic pump (Wheaton Unispense). At least two minutes before dispensing basal medium, serum bottles were made anaerobic by adding a cannula flowing with 70%N<sub>2</sub>/30%CO<sub>2</sub>. Upstream from the cannula, the N<sub>2</sub>/CO<sub>2</sub> mixture was continuously bubbled through a titanium chloride solution to remove trace levels of oxygen. After the medium was dispensed, a Teflon<sup>®</sup>-lined butyl rubber stopper and aluminum crimp seal were applied to the serum bottles. The ability of the stoppers to contain chlorinated ethenes and withstand needle punctures has been demonstrated previously (DiStefano, 1991). Bottles were incubated in an inverted position to minimize loss of volatile compounds. The temperature of the bottles was maintained at 35°C by an orbital shaker water bath.

To facilitate development of a mass balance on chlorinated ethenes, a technique was devised to remove the activated carbon from the six serum bottles during a culture transfer. Prior to the transfer, three of the carbon-containing bottles were autoclaved (125°C for 30 minutes) to serve as controls. After the three bottles were autoclaved, all the bottles were vigorously shaken in an attempt to remove as much biomass as possible from the carbon. Six serum bottles were prepared by anaerobically dispensing 40 mL of ABSM to 70-mL serum bottles. The bottles were sealed with Teflon<sup>®</sup>-lined butyl rubber stoppers and crimp caps were applied. Gas-tight syringes equipped with side-port needles were employed to transfer 10 mL of culture from the carbon-containing bottles to the bottles containing 40-mL of ABSM. The needle hole precluded the transfer of the activated carbon to the new bottles. Following the transfer, 10 mL of ABSM were added to each of the original bottles to replace the removed volume of medium. This anaerobic transfer thus resulted in the formation of six bottles with significantly reduced levels of activated carbon. Three of the bottles contained live culture; the other three contained autoclaved material and were used as controls.

## C. ANALYTICAL PROCEDURES

### 1. *Bioreactor Analysis*

The performance of the FBR was monitored using an SRI (SRI Instruments Inc., Torrance, CA) Model 9300 Gas Chromatograph (GC) equipped with flame ionization (FID) and photoionization (PID) detectors in series, and incorporated a purge-and-trap system for analysis of VOCs in water. The GC used a 105-meter MXT-624<sup>®</sup> 0.53 mm inside diameter capillary column (Restek Corp., Bellefonte, PA). Each GC run took 72 minutes, which included sampling, the purge-and-trap sequence, injection, and chromatographic separation. Primary standards were prepared for PCE, TCE, and BTEX compounds. The GC was equipped with a 5-

mL sample loop which gave detection limits of approximately 15 ppb for PCE and TCE, and 3 ppb for the BTEX components, using a peak area reject value of 100 units. The FID showed less shift in the standard curve than the PID during the project. Therefore, the FID was used exclusively for quantifying contaminant concentrations. The GC was calibrated a minimum of once each month (mandatory calibration). In addition, check standards for each target compound were run once each month between mandatory calibrations. If the average of the measured and actual check standard concentrations deviated by more than  $\pm 15\%$ , a new calibration curve was created. A water blank was run after each sample to clean the purge-and-trap unit and to assure that there was no cross contamination. At three time points, contaminant concentrations were also determined in liquid grab samples, which were analyzed using gas chromatography/mass spectroscopy (GC/MS) via SW-846 Method 8260 (purge-and-trap).

Vapors from the headspace of the FBR system were continually collected in Tedlar™ bags attached to the vapor headspace outlet port of the bioreactor. Filled bags were replaced with fresh bags an average of once every 2 weeks. Headspace samples were periodically analyzed for PCE, TCE, dechlorination products (VC, DCE, ethene, and ethane), and methane via direct injection (20  $\mu\text{L}$ ) onto a GC equipped with either an FID (for analysis of ethene, ethane, or methane) or an ECD (for analysis of chlorinated compounds).

## 2. *Aerobic TCE Bottle Assays*

Standard TCE bottle assays were performed on samples of biomass removed from the fluidized bed bioreactor and on enrichment cultures of bioreactor samples. For these assays, 10 mL of cell suspension were added to a 50 mL serum bottle, and biomass concentrations were determined by either (1) monitoring absorbance at 550 nm, or (2) measuring the total protein concentration (BCA Protein Assay, Pierce Chemical, Rockford, IL). Assays were also performed on blank samples, containing only deionized water, and "killed control" samples, containing biosolids plus 10  $\mu\text{L}$  of 50 mM  $\text{HgCl}_2$ . TCE (10  $\mu\text{L}$  of 40 mM in methanol) was added to the bottles, and the bottles were immediately sealed with Teflon®-lined septa and shaken on a rotary shaker. At defined time intervals, 20  $\mu\text{L}$  of air headspace was withdrawn from each bottle for TCE quantitation using a Varian Model 3400 GC equipped with split flame ionization and electron capture detectors (split FID and ECD). Contaminant separation was achieved using a 0.53 mm VOCOL™ capillary column (Supelco, Inc.). For bottle assays to confirm aerobic TCE degradation, toluene (10  $\mu\text{L}$  of 400 mM in methanol) was added to the bottles through the septa after 24 hours of incubation. For TCE assays performed on enrichment cultures, toluene was added initially with the TCE. Specific rates of TCE removal were calculated from the biomass concentrations and the decrease in TCE area counts as a function of time.

### 3. *Anaerobic Studies*

**Gas Chromatography Headspace Analysis of Volatile Organics and Hydrogen.** The total mass of each volatile organic (PCE, TCE, DCE isomers, vinyl chloride, ethene, and methane) and hydrogen within serum-bottle cultures was determined by a method involving a 0.3-mL headspace gas injection into a GC (Hewlett-Packard 6890) equipped with an FID and a thermal conductivity detector (TCD). For analysis of chlorinated ethenes, ethene, and methane, samples were injected into a 3.2-mm x 2.44-m stainless-steel column packed with 1 percent SP-1000 on 60/80 Carbopack-B® (Supelco, Inc.). The Carbopack® column was connected to the FID. For hydrogen analysis, samples were injected into a 3.2-mm x 3.2-m stainless-steel column packed with 100/120 Carbosieve-G® (Supelco, Inc.). The Carbosieve® column was routed to the TCD. The carrier gas for the Carbopack® column was nitrogen, whereas helium served as the carrier gas for the Carbosieve® column. The output from the detectors was sent to a microcomputer equipped with ChemStation® software (Hewlett-Packard). For all analyses, the oven was temperature-programmed as follows: 60°C for 2 minutes, followed by a temperature ramp of 20°C per minute up to 150°C, followed by a temperature ramp of 10°C per minute up to 200°C, with a hold at 200°C for 3.2 minutes.

GC calibration factors, resulting from a 0.3-mL headspace injection, were related to the total mass of each compound present in the serum bottles. Each neat compound was transferred to a known quantity of methanol in a sealed 14-mL vial. Quantities of compound and methanol were determined gravimetrically. A known mass of compound (in methanol) was determined gravimetrically and delivered by syringe to a 70-mL serum bottle. The serum bottle contained 50 mL of distilled water and was sealed with a Teflon®-lined butyl-rubber stopper and aluminum crimp cap. The bottle was equilibrated at 35°C, and then analyzed via a 0.3-mL headspace injection. Since vinyl chloride (VC), ethene (ETH), H<sub>2</sub>, and methane were obtained as gases, volumetric additions were made directly to the 70-mL serum bottles filled with 50 mL of distilled water. Standard mass additions to the serum bottles were determined from the ideal gas law. The coefficient of variation was used as the measure of precision for standards analysis. Coefficients of variation (standard deviation/mean x 100) for calibration factors (relating total mass of each volatile in a bottle to GC peak-area response) ranged from 1 to 4 percent for chlorinated ethenes and methane. A standard calibration curve was developed for hydrogen analysis; the correlation coefficient ( $r^2$ ) was 0.992.

**GC Analysis of Acetate.** Acetate was measured by a gas chromatographic technique using a Hewlett-Packard 5890 GC. A 0.5- $\mu$ L aqueous injection was made to a 0.53 mm x 30 m Innowax fused-silica capillary column (Hewlett-Packard) connected to an FID. The oven

temperature was programmed as follows: 100°C for 8 minutes, followed by a temperature ramp of 30°C per minute up to 150°C, with a hold at 150°C for 3.3 minutes. Samples (100-200 µL) were filtered through a 0.45-µm syringe filter (Gelman Sciences) and acidified with H<sub>3</sub>PO<sub>4</sub> prior to injection. Standard calibration curves were developed for acetate; the correlation coefficient ( $r^2$ ) was 0.998. Peak-area responses from subsequent samples were compared to the standard curves to obtain acetate concentrations.

**Analysis of Sulfate and Nitrate.** Sulfate and nitrate were measured during the characterization of the anaerobic culture from the bioreactor using a DX100 ion chromatograph (Dionex) equipped with a 4 x 500 mm IonPac AS4A column. The detection method used was suppressed conductivity, and the analytical method used was EPA Method 300.0(A).

**Total Iron Determination.** Total iron was measured during the characterization of the anaerobic culture from the bioreactor using a colorimetric assay (HACH® Assay Kit Model IR-18B).

**Analysis of Fe<sup>3+</sup> Reduction.** During the anaerobic culture characterization experiments, Fe<sup>2+</sup> production was determined by a modification of the methods described by Kazumi et al. (1995), Lovley et al. (1986), and Sorensen (1982). The method involved adding 0.5 mL of sample to 10 mL of 0.5 N HCl to extract acid-soluble iron, and shaking for 15 minutes. The HCl sample was then centrifuged, and an aliquot (100 µL) of the supernatant was added to 5 mL of ferrozine (1 g/L; Sigma) in 50 mM 4-(2-hydroxyethyl)-1-piperazineethanesulfonic acid (HEPES) buffer (pH-adjusted to 7.0 with NaOH). After mixing for 15 seconds, the mixture was passed through a 0.2 µm filter, and the absorbance at 560 nm was determined. Fe<sup>2+</sup> standards were made from ferrous sulfate (Mallinckrodt).

#### 4. <sup>14</sup>C[PCE] Experiments

After approximately 100 days of continuous flow-through operation, the FBR system was operated in recycle mode in preparation for radiolabeled <sup>14</sup>C[PCE] (Sigma) addition. Unlabeled PCE and BTEX were fed to the system batchwise before the start of the experiment. After 4 days in recycle mode, 150 mL of an aqueous solution containing 27,000 ppb each of PCE (with 0.074 µCi of <sup>14</sup>C[PCE] per mL of solution), benzene, toluene, ethylbenzene, and *o*-, *m*-, and *p*-xylene were injected into the bioreactor using a syringe at 8-hour intervals for 72 hours. Over this time period, the VOCs in the recirculating water were analyzed using the on-line GC. The total amount of radiolabeled <sup>14</sup>C[PCE] fed to the FBR system was approximately 100 µCi.

After the addition of <sup>14</sup>C[PCE], the system was operated in recycle mode for an additional 18 hours before samples were taken. Three fractions were collected for analysis: (1) solids; (2) liquid; and (3) vapor. The solids fraction was comprised of a GAC sample taken

directly from the reactor, which included attached biomass, and was analyzed for methanol-extractable radiolabeled organics. The liquid fraction was taken directly from the reactor, and was separately analyzed for total radiolabeled carbon, radiolabeled  $^{14}\text{CO}_2$ , and radiolabeled volatiles (compounds that could be stripped by air-sparging). The vapor fraction was comprised of gas headspace collected in the Tedlar<sup>®</sup> bag over the recirculation period, and was separately analyzed for radiolabeled  $^{14}\text{CO}_2$  and radiolabeled volatiles.

Organics from the GAC sample were extracted from the carbon using methanol. ENVIROGEN has demonstrated greater than 90 percent TCE spike recovery from GAC using these procedures in previous Air Force projects (Guarini and Folsom, 1996). Five grams (10 mL) of the wet GAC sample were extracted with 25 mL of methanol for 30 minutes. 100  $\mu\text{L}$  of the extract was added, in duplicate, to 10 mL of Optiphase 'Hi-Safe' III<sup>™</sup> scintillation cocktail (Wallac Oy, Inc., Turku, Finland) in two 20-mL scintillation vials. The vials were analyzed using a 1209 Rackbeta Liquid Scintillation Counter (Wallac Oy). The disintegration per minute (dpm) values were converted to dpm per mL of carbon analyzed, and the resulting values were multiplied by the total volume of GAC in the FBR system to determine the amount of radiolabel associated with the solid fraction.

Liquid analysis for total radiolabeled carbon after  $^{14}\text{C}[\text{PCE}]$  addition was achieved by adding 100  $\mu\text{L}$  of liquid from the reactor to 10 mL of Optiphase 'Hi-Safe' III<sup>™</sup> liquid scintillation cocktail. Three samples and one blank were prepared. The average of the resulting dpm values was converted into dpm per mL of liquid. The resulting figure was multiplied by the approximate liquid volume of the system to determine the amount of total radiolabel associated with the liquid fraction.

For analysis of radiolabeled  $^{14}\text{CO}_2$  and  $^{14}\text{C}[\text{VOCs}]$  within the liquid after  $^{14}\text{C}[\text{PCE}]$  addition, a 450 mL liquid sample from the bioreactor was acidified (10  $\mu\text{L}$  of concentrated HCl per mL of liquid) and sparged with air to remove  $\text{CO}_2$  and volatiles. Two air-sparging sequences were conducted. The first sparging sequence was accomplished using 35 mL per minute of air for 17 minutes. The off-gas was collected in a 1-L Tedlar<sup>™</sup> bag and absorbed into  $^{14}\text{CO}_2$ - and  $^{14}\text{C}[\text{VOC}]$ -selective scintillation cocktails as described below for the FBR headspace analysis. The liquid was then sparged for an additional 30 minutes to remove any residual  $\text{CO}_2$  and volatile organics. For this second 30 minute sparging sequence, the off-gas was directly connected to the vapor absorption train. The absorbed  $^{14}\text{CO}_2$  and  $^{14}\text{C}[\text{VOCs}]$  within the scintillation cocktails was analyzed using a scintillation counter. The resulting dpm values were combined to give the total disintegrations per minute recovered. The dpm values were converted to dpm per mL of liquid analyzed, and the resulting values were multiplied by the estimated volume of liquid in the FBR system to determine the amount of radiolabeled  $^{14}\text{CO}_2$  and volatile organics associated with the liquid fraction after  $^{14}\text{C}[\text{PCE}]$  addition.

During the  $^{14}\text{C}[\text{PCE}]$  experiments, a Tedlar™ bag was attached to the bioreactor headspace effluent port to collect off-gas from the bioreactor. However, the off-gas from the bioreactor only partially inflated the Tedlar™ bag during the experiment. Two vapor analyses were run. The contents of the inflated Tedlar™ bag, which contained approximately 70 mL of vapor, were analyzed first. For the second analysis, approximately 100 mL of additional vapor was removed from the bioreactor headspace using a 100 mL gas-tight syringe, and injected into a second Tedlar™ bag. For both analyses,  $^{14}\text{CO}_2$  and  $^{14}\text{C}[\text{VOCs}]$  were measured by passing the contents of the bags through a series of six 20-mL scintillation vials containing  $^{14}\text{CO}_2$ - and  $^{14}\text{C}[\text{VOC}]$ -selective scintillation cocktails. The vials were all connected by Teflon® tubing. The Tedlar™ bag was attached to the train inlet, and a sampling vacuum pump was attached to the train outlet. The first and fourth scintillation vials in the series were empty to catch any backflow that might occur. The second and third vials contained 10 mL each of a toluene-based general-purpose scintillation cocktail (Liquiscint™, National Diagnostics, Atlanta, GA) for capture of volatile organics. The fifth and sixth vials contained 10 mL each of a  $^{14}\text{CO}_2$ -specific scintillation cocktail, Oxosol C<sup>14</sup>™ (National Diagnostics), designed for the capture of radiolabeled  $^{14}\text{CO}_2$ . The collected vapor headspace in the Tedlar™ bag was pulled through the series of vials at a rate of 36 mL per minute. The absorbed  $^{14}\text{CO}_2$  and  $^{14}\text{C}[\text{VOCs}]$  were analyzed using a scintillation counter. The resulting dpm values for each cocktail were added to give the total disintegrations per minute recovered in each cocktail (vials 2 plus 3 for the  $^{14}\text{C}[\text{VOC}]$ -selective cocktail; vials 5 plus 6 for the  $^{14}\text{CO}_2$ -specific cocktail). For the Liquiscint™ cocktail, 65 percent of the radiolabel was collected in the first vial of the 2-vial set. For the Oxosol C<sup>14</sup>™ cocktail, 75 to 90 percent of the radiolabel was collected in the first vial of the 2-vial set. The dpm values were converted to dpm per mL of vapor analyzed, and the resulting values were multiplied by the estimated volume of bioreactor headspace to determine the amount of radiolabeled  $^{14}\text{CO}_2$  and volatile organics in the headspace after  $^{14}\text{C}[\text{PCE}]$  addition.

#### D. CONTINUOUS BIOREACTOR OPERATIONS

A schematic of the laboratory-scale FBR system used for this project is shown in Figure 2. The laboratory-scale FBR system was constructed from glass with Teflon® and stainless steel tubing and fittings to minimize abiotic chemical losses. The system had a total liquid volume of 4.5 L. Feed water entering the reactor was artificially contaminated with PCE, TCE, and BTEX using a syringe pump and a 12 L equalization tank. Soluble nutrients ( $\text{NH}_4\text{Cl}$ ,  $\text{K}_2\text{HPO}_4 \cdot 3\text{H}_2\text{O}$ ,  $\text{NaH}_2\text{PO}_4 \cdot \text{H}_2\text{O}$ , and trace metals) were added to the feed water in a 55-gallon drum before the feed was mixed with the contaminants. Granular activated carbon (GAC) was added to the reactor to give a settled bed volume of approximately 800 mL, which was fluidized to an

expanded bed height of 125% of the original bed height using a gear pump on the recycle line. Contaminated water was fed at a rate of  $17 \pm 4$  mL per minute using a peristaltic pump, corresponding to an expanded bed hydraulic retention time (HRT) of approximately 1 hour. The HRT was calculated based on expanded bed volume and feed flowrate, and assumed that no significant biodegradative activity was occurring in other wetted areas of the reactor. Dissolved oxygen was maintained between 0.25 and 3.5 ppm (average 0.5 ppm) through an automated control system designed to minimize volatile losses of contaminants. Air or oxygen sparging was not employed, and therefore the liquid at the top of the reactor was maintained in a quiescent state. The recirculating liquid in the recycle line was contacted with pure oxygen under pressure within a glass tube (oxygenator). The recirculating liquid level in the oxygenator was monitored using a reservoir monitor which opened a solenoid valve, thereby maintaining a fixed volume of pure oxygen in the oxygenator. Liquid was discharged from the system automatically through a solenoid valve when the liquid level at the top of the reactor reached a preset level via a level control switch. The pH of the liquid was automatically controlled at  $7.0 \pm 0.4$  through the addition of 2 N NaOH or 1 N HCl, and the temperature of the liquid was maintained at  $30 \pm 4^\circ\text{C}$ .

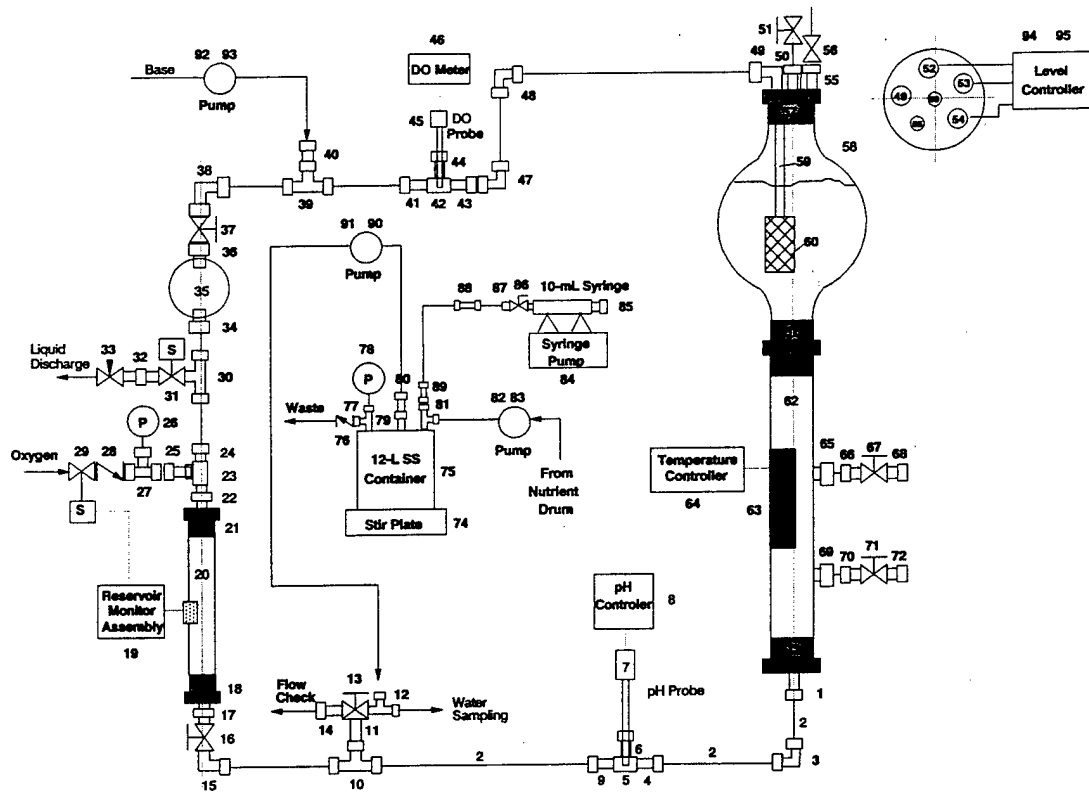

Figure 2. Laboratory-scale Dual Anaerobic/Aerobic FBR System Schematic.

### III. RESULTS

#### A. FBR PERFORMANCE

##### 1. *Abiotic Control Experiments*

The FBR system was first operated in a flowthrough mode without GAC or biomass to assess the extent of abiotic loss of contaminants from the system. Abiotic losses can occur through adsorptive, permeation, and absorptive mechanisms. Figure 3 shows the abiotic loss of PCE, TCE, and benzene from the system over a 10 day operating period. The loss of contaminants from the system averaged approximately 12 percent in the absence of GAC and biomass.

##### 2. *GAC Loading*

Before the system was inoculated, GAC isotherm experiments were conducted using the contaminant feed mixture to assess the extent of contaminant adsorption onto the carbon during operation of the system, and also to determine the amount of contaminant mixture needed to saturate the carbon. The synthetic feed mixture was prepared as follows: 5 ppm each of PCE and TCE; 3 ppm each of benzene and ethylbenzene; 10 ppm of toluene; and 1.5 ppm each of *o*-, *m*-, and *p*-xylene. This mixture was added to two sets of 150 mL serum bottles containing 0.00, 0.075, 0.15, 0.3, 1.0, and 2.0 grams of the GAC used in the FBR. Each bottle received 150 mL of liquid. The bottles were sealed with Teflon<sup>®</sup>-lined crimp-seal rubber septa and agitated at room temperature for 120 minutes (This time period was determined in a previous experiment to be above the minimum time required to reach equilibrium). After the agitation period, 5 mL of the liquid were removed from each bottle and analyzed for VOCs via SW-846 Method 8260 (GC-MS purge-and -trap). Based on these analyses, the adsorption isotherm for TCE and PCE shown in Figure 4 was obtained. Similar adsorption isotherms were obtained for the BTEX components.

After the GAC isotherms were determined, the activated carbon (375 to 400 grams) in the bioreactor was loaded with neat TCE (2.2 grams), PCE (2.2 grams), and BTEX (12.8 grams) in the same proportions as the feed mixture. Residual neat contaminant at the top surface of the GAC was observed after 16 hours of operation in recycle mode. Because of this observation, it was assumed that the GAC was completely saturated with contaminant. Approximately half of the residual contaminant was removed using a vacuum pump attached to 1/4-inch Teflon<sup>®</sup> tubing. To remove the remainder of the residual contaminant, the system was shut off, and water

from the top of the reactor was removed until the liquid level dropped to the GAC surface. The reactor was then filled with fresh water and allowed to sit for approximately 10 minutes. This procedure was repeated four times until very little residual contaminant was observed. The system was then operated in continuous recycle mode for an additional 48 hours, and the recirculating water was analyzed for VOCs to determine residual VOC levels and adsorbed contaminants. Based on these measurements and the GAC isotherms, the total TCE and PCE in the system at start-up was estimated to be 480 mg for TCE and 440 mg for PCE.

### 3. *Inoculation and Start-up*

After loading the GAC, the system was inoculated with anaerobic sludge from a local wastewater treatment plant treating industrial and municipal waste. The system was operated anaerobically for a period of 8 days in batch mode to allow for microbial attachment. During this period, glucose was added to the system as a carbon and energy source, and methane generation was detected. For the first 24 hours, N<sub>2</sub> gas was bubbled through the system at a slow rate of 5 mL per minute (7.2 L total) to maintain anaerobic conditions. The system was then inoculated with the TCE-degrading bacterium *Burkholderia cepacia* G4, and was operated in recycle mode for 5 more days with O<sub>2</sub> feed (through the oxygenator). After 5 days, the system was operated in a flowthrough mode under aerobic conditions with an HRT of 1 hour.

### 4. *Continuous Operation*

**Influent and Effluent Water Analyses.** Influent and effluent PCE and TCE concentrations, as measured using the on-line GC, are shown in Figures 5 and 6, and Figures 7 and 8 show the effluent PCE and TCE concentrations on an expanded scale. Over the first 35 days of operation, influent PCE and TCE concentrations were generally maintained between 2,000 and 8,000 ppb, and the (toluene)/(TCE+PCE) ratio was maintained at approximately 1. On Day 37, the (toluene)/(TCE+PCE) ratio was increased to 10. Between Days 35 and 60, influent PCE and TCE concentrations were reduced to 100 to 1,000 ppb due to mechanical feed problems. These problems were resolved, and after Day 64, influent PCE and TCE concentrations were generally stable between 1,000 and 2,000 ppb. On Day 87, TCE was removed from the feed mixture.

During the operation of the FBR system, the effluent quality remained high. The average O<sub>2</sub> consumption rate over the experiment was approximately 0.65 mg per minute, which was determined by periodically measuring the change in O<sub>2</sub> gas volume in the oxygenator over a 30 minute period. BTEX removal efficiencies were consistently greater than 99 percent, and PCE

effluent concentrations were between 40 and 180 ppb, regardless of influent PCE levels. After Day 35, effluent PCE concentrations dropped from an average of approximately 150 ppb to approximately 80 ppb, corresponding to the drop in influent PCE concentration. Three grab samples of the liquid effluent from the bioreactor were collected on Days 72, 86, and 94 for VOC analysis using SW-846 Method 8260 (GC-MS purge-and-trap). No vinyl chloride (VC) or *cis*-1,2-DCE were detected in any of the samples. The fact that VC and DCE were not detected in the bioreactor effluent indicates no build-up of PCE dechlorination products, and provide support for aerobic cometabolic activity. The PCE removal efficiency during the third month of operation was approximately 90 percent, when the influent PCE concentration was steady at approximately 1,200 ppb (Days 77 to 107). In the case of TCE, effluent concentrations increased over the first 35 days of operation, corresponding to an increase in influent TCE concentrations, but the removal efficiency remained between 94 and 98 percent during this period. After Day 35, effluent TCE concentrations dropped along with influent concentrations, but not as dramatically as PCE, possibly due to TCE formation from PCE. After Day 35, consistent TCE effluent quality between 350 and 450 ppb was observed regardless of influent TCE concentrations, even when TCE was removed from the feed (see Figures 6 and 8). The TCE removal efficiency during the third month of operation was approximately 83 percent when the influent TCE concentration was steady at approximately 2,600 ppb (Days 67 to 87).

**VOC Headspace Analysis.** During steady-state operation, from days 66 to 80, two headspace samples were analyzed for PCE, TCE, and their dechlorination products VC and DCE. The vapor was also analyzed for methane, ethane, and ethene. The TCE concentration in the headspace averaged 70  $\mu\text{g/L}$  over this period, approximately 50% of the concentration predicted on the basis of a dimensionless Henry's law coefficient of 0.4 for TCE (Folsom et al., 1990) and a measured recirculating water concentration of 350 ppb. The PCE concentration averaged only 40  $\mu\text{g/L}$ , also approximately 50% of the predicted vapor concentration, based on a dimensionless Henry's law coefficient of 1.0 for PCE (Mackay and Shiu, 1981) and a measured recirculating water concentration of 75 ppb. Since the average vapor discharge rate from the system was estimated to be only approximately one 1-L Tedlar™ bag every 2 weeks, the mass of TCE and PCE removed in the vapor over the length of the project, based on the measured headspace concentrations, was less than 1 mg.

No intermediate products of PCE dechlorination (VC, DCE, ethene, or ethane) were detected in the headspace, although low levels of methane (30 to 40  $\mu\text{g/L}$ ) were detected. It cannot be determined conclusively whether this methane was produced during the bulk aerobic phase of reactor operation or if it was residual methane produced during the complete anaerobic phase.

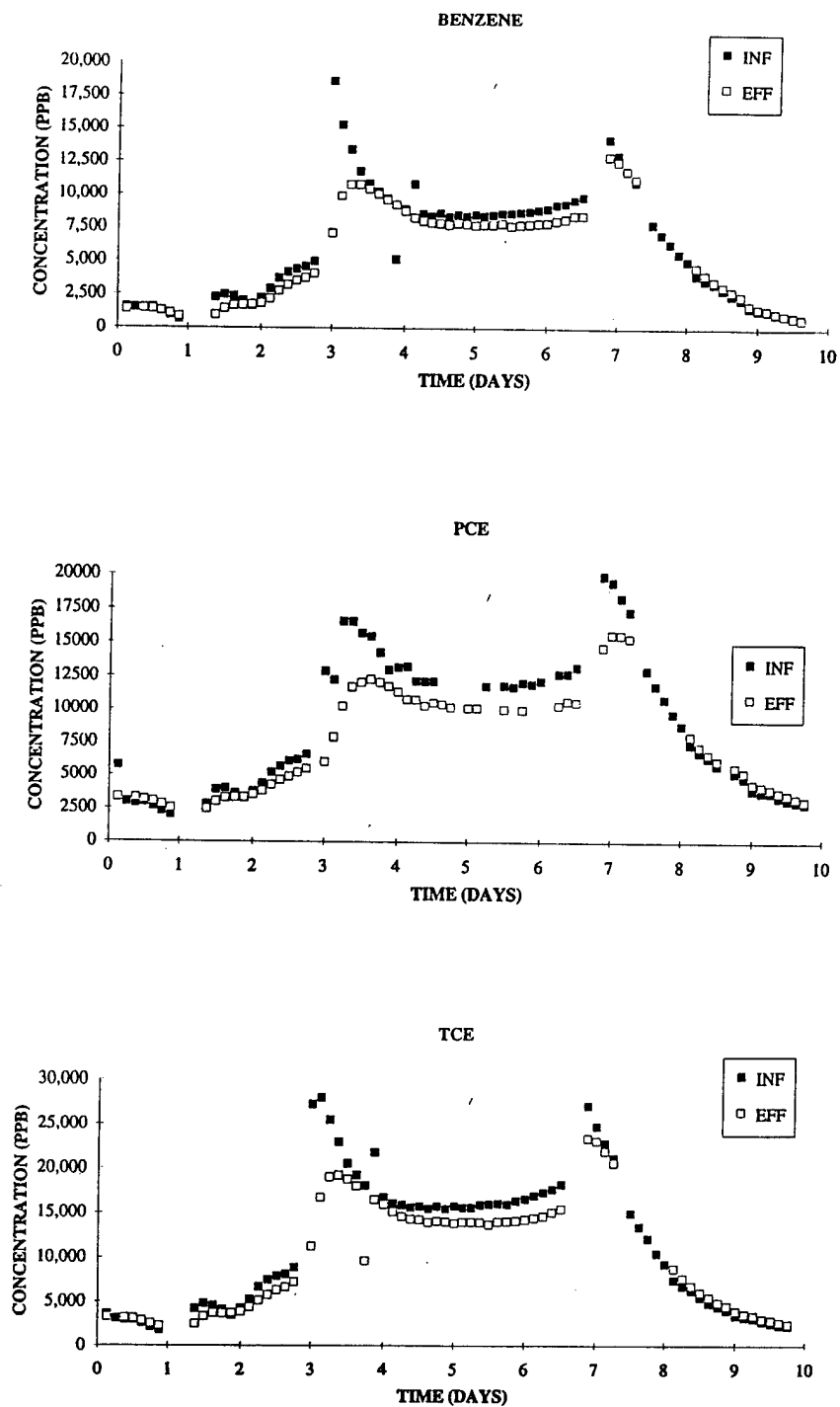

**Figure 3. Abiotic Loss of Contaminants from the Laboratory-scale FBR System.** The system was operated without GAC or biomass for 10 days. Influent (INF) and effluent (EFF) concentrations were measured using an on-line purge-and-trap GC system.

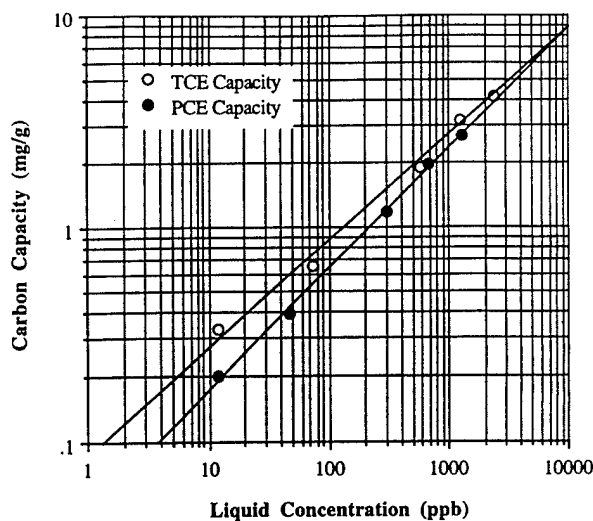

**Figure 4. GAC Adsorption Isotherms for TCE and PCE at Room Temperature Using the FBR Feed Mixture.** The synthetic feed mixture was prepared as follows: 5 ppm each of PCE and TCE; 3 ppm each of benzene and ethylbenzene; 10 ppm of toluene; and 1.5 ppm each of *o*-, *m*-, and *p*-xylene.

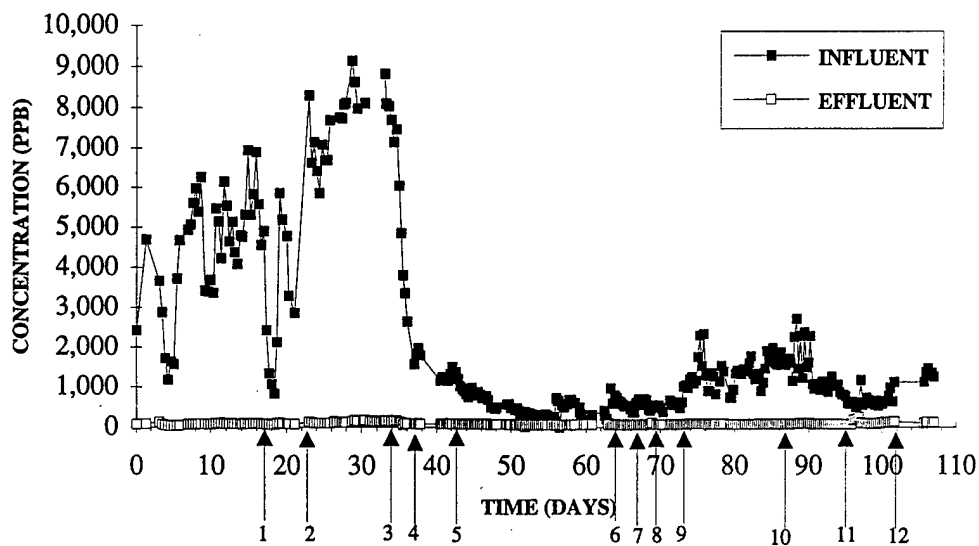

**Figure 5. Influent and Effluent PCE Concentrations During Operation of the Laboratory-scale FBR System.** The numbers below the graph correspond to: (1) liquid loss from the system; (2) GAC samples collected; (3) contaminant feed rate reduced; (4) (toluene)/(TCE+PCE) ratio increased from 1 to 10; (5) HRT accidentally increased to 2 hour HRT and nutrient addition cut in half; (6) steady influent concentrations achieved; (7) pump added to outlet side of equalization tank; (8) 100 mL of G4 culture added to system; (9) PCE concentration increased; (10) TCE removed from contaminated feed; (11) recirculation pump problems; and (12) system upset due to recirculation pump.

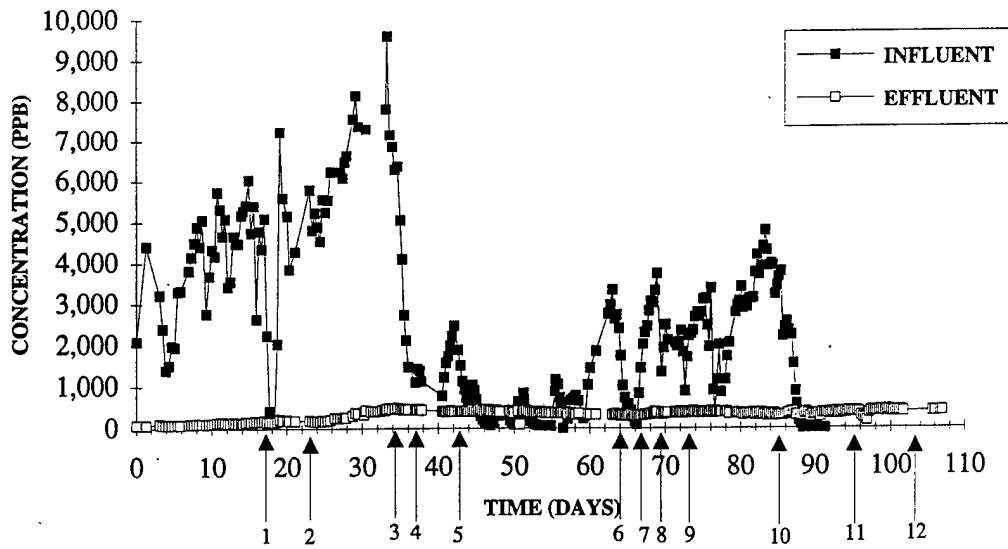

**Figure 6. Influent and Effluent TCE Concentrations During Operation of the Laboratory-scale FBR System.** The numbers below the graph correspond to the same system changes shown in Figure 5.

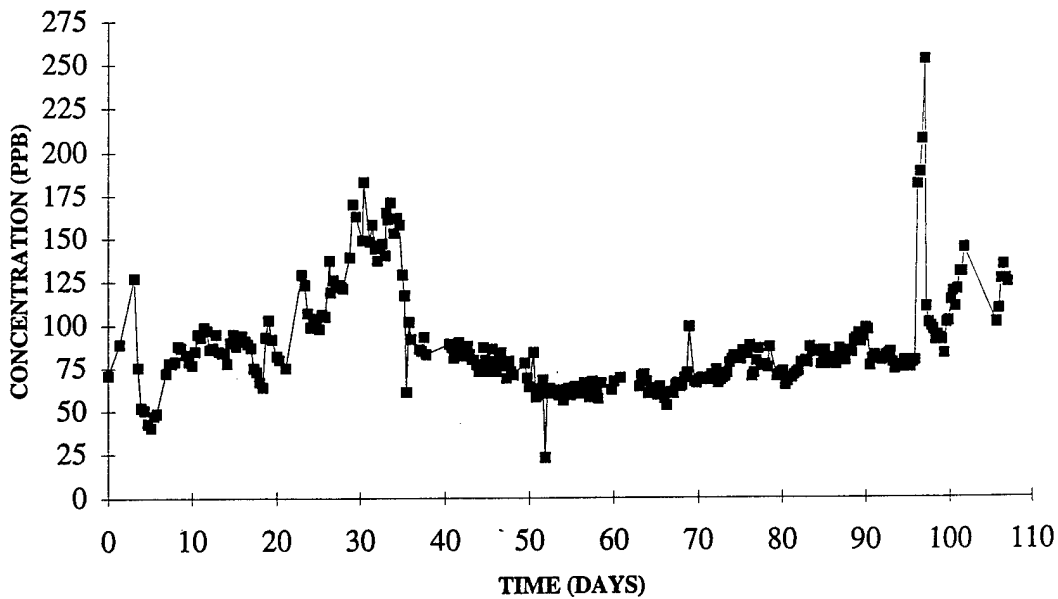

**Figure 7 Effluent PCE Concentrations During Operation of the Laboratory-scale FBR System.** The numbers below the graph correspond to the same system changes shown in Figure 5.

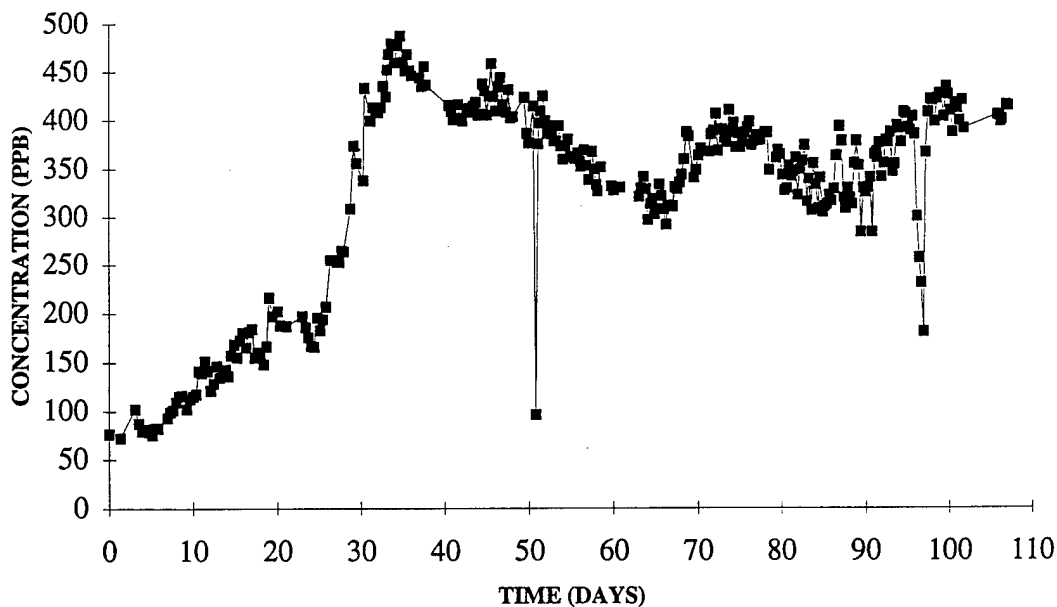

**Figure 8. Effluent TCE Concentrations During Operation of the Laboratory-scale FBR System.** The numbers below the graph correspond to the same system changes shown in Figure 5.

#### 5. *TCE and PCE Mass Balances*

At the completion of the project, while the bioreactor was operated in recycle mode, a sample of the GAC within the system was withdrawn and extracted with methanol for analysis of adsorbed TCE and PCE. ENVIROGEN has demonstrated greater than 90 percent TCE spike recovery from GAC using these procedures (Guarini and Folsom, 1996). A GAC sample was removed through one of the side ports in the reactor column. 1.5 grams (3 mL) of the carbon was extracted with 5 mL of methanol at 6°C to remove adsorbed TCE and PCE. The methanol extract was analyzed via GC-MS using SW-846 Method 8260 (purge-and-trap). Estimates of the total mass of TCE and PCE added to the system in the influent feed stream, and removed from the system in the liquid effluent, were obtained by integrating the areas under the curves in Figures 5 and 6 (via the Trapezoid Rule), and multiplying by the volumetric liquid flowrate (24 L/day). Finally, an estimate of the TCE and PCE discharged from the system in the vapor phase was determined by multiplying the average TCE and PCE concentrations detected in the bioreactor headspace by the estimated vapor discharge rate of one 1-L Tedlar® bag every 2 weeks.

The results from the TCE and PCE mass balance calculations are shown in Table 1. Based on these results, approximately 80 and 90 percent of the TCE and PCE added to the system during the experiment was degraded, respectively. As a check of the GAC adsorption results, the TCE and PCE concentrations in the bioreactor were measured at the end of the project while the system was in complete recycle (batch) mode, and the measured concentrations were used to predict adsorbed TCE and PCE based on the GAC isotherms in Figure 4. Table 2 shows this comparison. As shown in Table 2, the predicted and measured amounts of adsorbed TCE and PCE on the carbon at the end of the experiment are comparable.

The mass balance calculations shown in Table 1 are conservative. Toward the end of the project, right after the on-line GC had been calibrated, contaminant concentrations were determined in influent and effluent liquid grab samples over a 3 week period using SW-846 Method 8260 (GC/MS purge-and-trap). Three samples were taken: one on day 72, the second on day 86, and the third on day 94. The GC was calibrated on day 71. Tables 3 and 4 show influent and effluent contaminant concentrations measured using the on-line GC compared to the grab sample measurements. Influent PCE concentrations in all 3 grab samples were higher than influent PCE concentrations measured with the on-line GC - 3 to 5 times higher in two of the samples. Likewise, influent TCE concentrations for 2 of the 3 grab samples were higher than concentrations measured with the on-line GC. In contrast, the TCE and PCE concentrations in all 3 grab samples were between 25 and 60 percent less than concentrations measured with the on-line GC. Part of the reason for the large discrepancy between the on-line and grab sample measurements may be the wide range of concentrations that the on-line GC measured. If the grab sample data are used to adjust the estimates of the amounts of TCE and PCE added and removed from the FBR during continuous operation (50 percent less TCE and PCE in effluent; 2 times higher TCE in influent; and 4 times higher PCE in influent), then the overall percentage of TCE and PCE degraded by the FBR increase to 95 and 98 percent, respectively.

**Table 1. Results of TCE and PCE Mass Balances**

	Mass Added (mg)			Mass Removed (mg)				Mass Degraded	Percent Degraded
	Loading	Feed*	Total	GAC Adsorbed	Liquid Effluent	Vapor Discharge	Total		
<b>TCE</b>	480	2,870	3,350	310	370	0.6	680	2,670 mg	80
<b>PCE</b>	440	2,390	2,830	250	86	0.4	340	2,490 mg	88

\* Including material added during radiolabeling experiments

**Table 2. A Comparison of the Measured (Methanol Extraction) and Predicted (GAC Isotherm) Carbon Adsorption at the End of the Experiment**

	Liquid Concentration (ppb)	Mass of Contaminant Adsorbed (mg)*	
		GAC Isotherms	Methanol Extraction
<b>TCE</b>	300	520	310
<b>PCE</b>	60	190	250

\* Based on 375 grams of carbon in the system at the end of the experiment.

**Table 3. A Comparison of Influent Grab Sample and On-line GC Measurements**

	Day 72		Day 86		Day 94	
	On-line Average	Grab Sample	On-line Average	Grab Sample	On-line Average	Grab Sample
TCE	2,080	4,600	2,396	570	N/D	960
PCE	547	2,000	1,709	2,400	885	4,000
Toluene	11,198	47,000	12,743	11,000	12,526	69,000
Benzene	2,535	7,500	2,783	5,400	2,648	11,000
Ethylbenzene	2,627	6,000	3,228	4,600	1,582	4,600
m-, p-Xylene	3,184	3,000	3,452	1,800	3,666	5,200
o-Xylene	2,585	3,800	2,655	2,700	2,428	5,400

N/D = not detected

**Table 4. A Comparison of Effluent Grab Sample and On-line GC Measurements**

	Day 72		Day 86		Day 94	
	On-line Average	Grab Sample	On-line Average	Grab Sample	On-line Average	Grab Sample
TCE	389	180	360	160	397	260
PCE	70	44	80	43	77	56
Toluene	87	N/D	134	N/D	126	71
Benzene	8	N/D	10	N/D	32	N/D
Ethylbenzene	15	N/D	22	N/D	10	N/D
m-, p-Xylene	30	N/D	44	N/D	34	N/D
o-Xylene	20	N/D	27	N/D	22	N/D

N/D = not detected

#### B. AEROBIC CULTURE PERFORMANCE

After three weeks of operation, samples of the GAC support material were removed from the FBR through side ports in the glass column. Two samples were collected. One sample was collected from the middle of the FBR bed; the other sample was taken from the top of the FBR bed. A sample of the suspended solids (biomass) at the top of the reactor was also collected. Biomass was removed from the GAC support by vigorously shaking the material, and standard TCE bottle assays were performed on all the samples (see Section C.2). Figure 9 shows the results of the TCE bottle assay performed on the biomass from the GAC sample removed from the middle of the FBR bed. The results for the other biomass samples were similar, and indicate that the bacterial population removed from the GAC within the laboratory-scale FBR had TCE cometabolic degradative activity. The specific TCE degradation rate of the biomass removed from the GAC was 0.04 to 0.08 nmoles per minute per mg of total protein (nmoles/minute•mg); the specific TCE degradation rate of the suspended solids removed from the top of the reactor was 0.02 to 0.05 nmoles/minute•mg. These specific TCE degradation rates are comparable to rates observed during long-term operation of ENVIROGEN's TCE Gas-phase Reactor (GPR) utilizing *Burkholderia cepacia* G4 and phenol as a co-substrate for TCE oxidation (ENVIROGEN, unpublished results). The specific TCE degradation rates observed for the FBR were between 2 and 7 percent of the specific TCE degradation rate of the pure *B. cepacia* G4

strain used to inoculate the system (1.2 nmoles/minute•mg), which is also typical of previous field experiences.

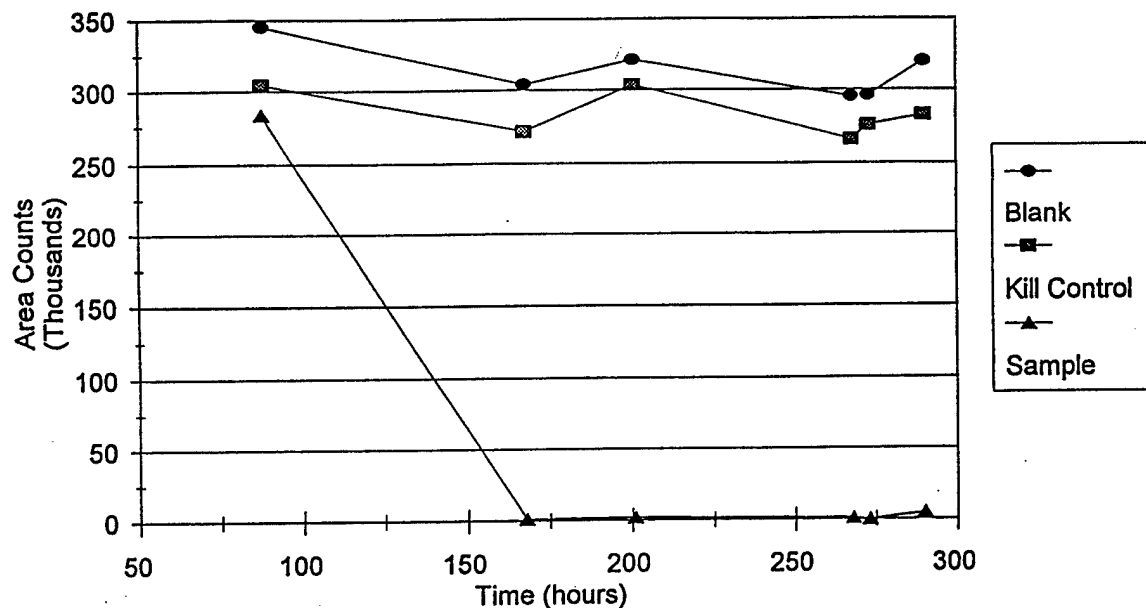

**Figure 9. TCE Bottle Assay Results.** Each bottle contained 10 mL of culture and 10  $\mu$ L of 40 mM TCE. 10  $\mu$ L of 400 mM toluene was added to each bottle at 27.5 hours. The "killed control" bottle contained 10 mL of culture and 10  $\mu$ L of 50 mM  $HgCl_2$ .

### C. ANAEROBIC CULTURE PERFORMANCE

#### 1. Cultures with Activated Carbon

Six 70-mL serum bottles that contained activated carbon from the reactor were placed under anaerobic conditions as described previously (see Section II.C.3). The six bottles were prepared to investigate if the culture in the FBR was capable of mediating reductive dechlorination of PCE under anaerobic conditions. Each bottle was fed 144  $\mu$ moles of methanol (92 mg/L), 1.8  $\mu$ moles PCE (6 mg/L nominal dose, ignoring partitioning to the bottle headspace), and 40 mg/L yeast extract. Methanol was added, based on its proven ability to serve as an electron donor for biological reductive dechlorination. Yeast extract was added to provide

potential necessary growth factors for the culture. After feeding, the bottles were inverted and incubated in an orbital shaker water bath maintained at 100 rpm and 35°C. Headspace samples from each bottle were analyzed after 2 to 3 days of incubation. TCE, DCE, and methane were detected in samples from each bottle. However, less than 10 percent of the PCE added to each bottle could be accounted for as TCE or DCE. The bottles were routinely fed methanol, PCE, and yeast extract. Headspace was analyzed after each incubation period. Figure 10 shows the results from one bottle. The other five bottles performed similarly.

The presence of DCE provided evidence of reductive dechlorination occurring within the bottles. Methane (not shown) was also detected in each bottle. Over time, the fraction of detected chlorinated ethenes existing as DCE increased. Because PCE was added after each measurement, the overall quantity of measured ethenes should have increased. However, the total mass of chlorinated ethenes remained relatively constant. Adsorption to the activated carbon in the bottles (3.5 grams per bottle) is considered the likely cause for the relatively constant total mass of detected ethenes, based on adsorption isotherms completed during this work and by others (Dobbs and Cohen, 1980) (Based on previous work, sorption of chlorinated ethenes by the anaerobic basal media or significant loss from the bottles was not likely.). All six carbon-containing bottles produced similar results. Based on these results, it was concluded that biomass within the reactor supported anaerobes that were capable of mediating reductive dechlorination of PCE.

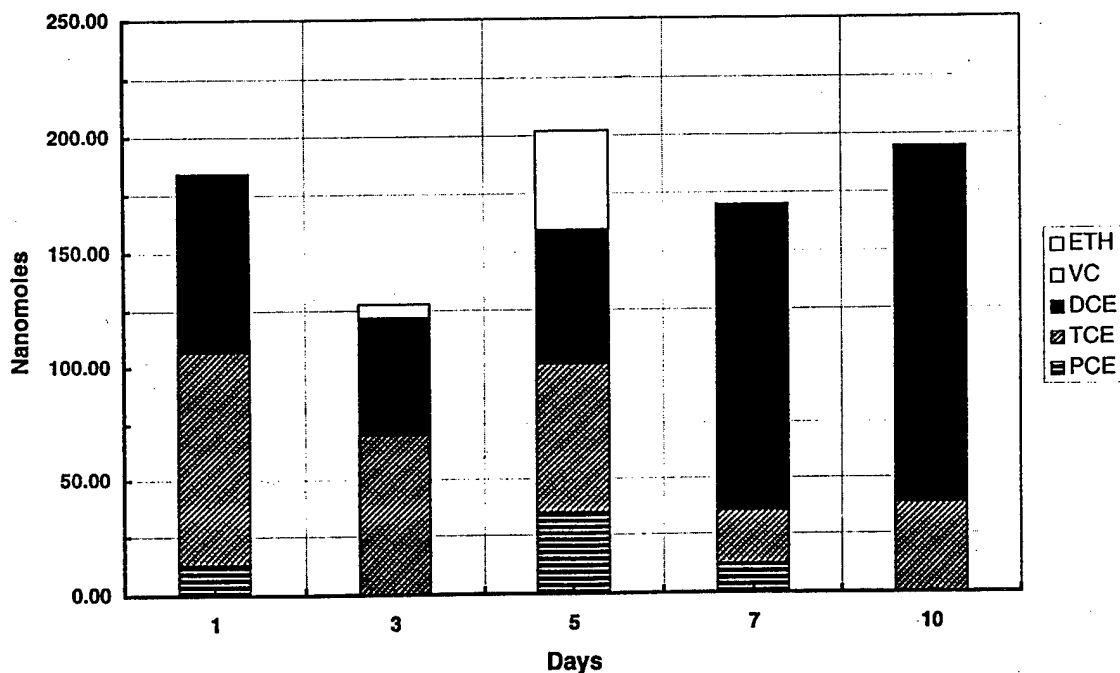

Figure 10. Evidence of Reductive Dechlorination (Bottle "Top-1").

## 2. *First Generation Cultures without Activated Carbon*

**Methanol and Hydrogen as Electron Donors.** First generation cultures without activated carbon were prepared by subculturing a 20 percent inocula from the carbon-containing bottles. Biomass was removed from the activated carbon during subculturing as described in Section II.B.4. The anaerobic transfer from the carbon-containing bottles resulted in the formation of six bottles without activated carbon. Prior to the transfer, three of the carbon-containing bottles were autoclaved. Therefore, three of the subcultured bottles contained live culture while the other three served as killed controls. Each bottle was initially fed 1.8  $\mu$ moles of PCE (6 mg/L nominal dose), 75  $\mu$ moles of methanol (48 mg/L), and 20 mg/L of yeast extract. The methanol dose was adjusted to reduce the methanol/PCE ratio to approximately half the ratio used in the previous experiments (14.4  $\mu$ eq of PCE and 450  $\mu$ eq of methanol were added to each bottle on an electron equivalent basis). However, a substantial excess of reducing equivalents was still provided by the methanol to completely dechlorinate all of the added PCE to ethene. Headspace analyses were routinely performed after 1 to 2 days of incubation. After the analyses were complete, the three live cultures were routinely fed methanol and yeast extract as described; PCE was added after the previous dose was dechlorinated. Autoclaved control bottles were not fed because neither a decrease in PCE nor production of methane was detected, indicating that the observed PCE dechlorination was biologically mediated.

After 12 days, methanol additions ceased and hydrogen was added to serve as an electron donor. The cultures routinely received 5.5 mL (435  $\mu$ eq) of hydrogen. PCE dechlorination continued after hydrogen was added as the electron donor. This is in agreement with previous work (DiStefano, 1992) that suggests that hydrogen may be the direct electron donor for PCE reduction. The reactor received PCE, TCE, and BTEX; among these compounds, only toluene has been shown to support PCE dechlorination (Sewell and Gibson, 1991). Hydrogen, formed as an intermediate during BTEX degradation, may therefore have served as the electron donor for the anaerobes in the bioreactor.

Figure 11 shows products of PCE reduction - trichloroethylene (TCE), dichloroethene (DCE), vinyl chloride (VC), and ethene (ETH) - and cumulative PCE added for one of the three live cultures. The two replicate bottles performed similarly. After 14 days, nearly complete removal of PCE was detected in the live bottles, and a second dose of PCE was provided. The second dose was dechlorinated in 7 days and a third dose of PCE was administered. To achieve the desired dose of 1.8  $\mu$ mol PCE, 1.8 mL of PCE-saturated water was added to each bottle. To maintain a constant liquid volume, 1.8 mL of culture was removed prior to PCE addition.

Comparison of the cumulative PCE added with each day of summed products of dechlorination indicates good closure of a mass balance. Throughout the 24-day study, measured

products of dechlorination represented 94% to 103% of cumulative PCE added (PCE added was calculated based on volumetric addition via syringe. PCE remaining after incubation, and products of dechlorination, were quantified via GC-FID headspace analysis.). VC was observed after 10 days and ETH after 14 days. VC and ETH production was observed routinely thereafter. With time, VC represented the major proportion of dechlorinated products; TCE was not detected and insignificant quantities of DCE were measured.

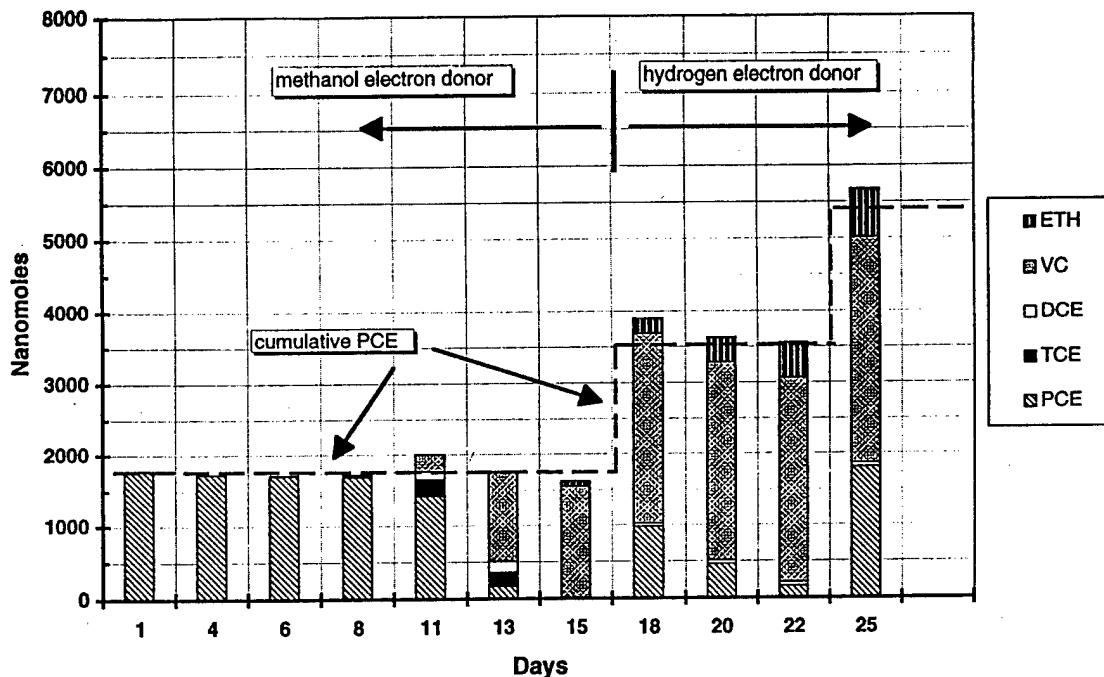

Figure 11. Chlorinated Ethenes Mass Balance (Bottle ENV-NC-2).

**Electron Balance.** An electron balance was completed on the hydrogen-fed bottles. Previously, the hydrogen added (435  $\mu\text{eq}$ ) far exceeded the electron donor requirement for complete dechlorination of PCE to ETH (48  $\mu\text{eq}$ ). Methane routinely accounted for 50 to 75 percent of hydrogen consumption. For the electron balance, 0.3 mL of PCE-saturated water (0.3-0.4  $\mu\text{moles}$ ) and 5.5 mL (218  $\mu\text{moles}$ ) of hydrogen were added to each bottle. PCE and hydrogen were thus used as starting compounds and the balance was checked by comparing the  $\mu\text{eq}$  of hydrogen consumed with the sum of  $\mu\text{eq}$  of reduced products formed.  $\text{CO}_2$  was used as a reference for methane and acetate, whereas PCE was used as a reference for TCE, DCE, VC, and ethene. The electron equivalent conversion factor for methane and acetate is 8  $\mu\text{eq}/\mu\text{mole}$ . The

conversion factors ( $\mu\text{eq}/\mu\text{mole}$ ) for TCE, DCE, VC, and ETH are 2, 4, 6, and 8, respectively. The electron balance for one of the three replicates is shown in Table 5; similar patterns of hydrogen use was apparent in the replicate cultures. The electron balance indicates hydrogen was used completely, and that methane production accounted for approximately 75 percent of the hydrogen use. Due to the excess of reducing equivalents provided, PCE dechlorination accounted for only a very minor fraction of hydrogen use after a two-day incubation period. Acetate was not detected in the samples. The fate of the remaining 25 percent of the reducing equivalents supplied by hydrogen is unknown.

**Table 5. Electron Balance for a Hydrogen-fed Bottle (ENV-NC-3)**

Compound	Amount Present ( $\mu\text{mole}$ ) on day:		Difference	Factor ( $\text{eq}/\text{mole}$ )	Hydrogen Consumed ( $\mu\text{eq}$ )	Product formed ( $\mu\text{eq}$ )
	1	3				
Hydrogen	206.27	0	206.27	2	412.54	
PCE	0.42	0.35	0.07	0		
TCE	0	0	0	2		
DCE	0	0	0	4		
VC	1.84	1.91	0.07	6		0.45
Ethene	0.03	0.05	0.02	8		0.16
CH <sub>4</sub>	183	220	37.33	8		298.64
						$\Sigma = 299.25$

### 3. *Second Generation Cultures.*

**Toluene as Electron Donor.** Because toluene has been observed by others (Sewell and Gibson, 1991) to support PCE reduction, and because toluene was continually supplied to the bioreactor, cultures were prepared to determine if toluene could serve as an electron donor. Gas-tight syringes equipped with side-port needles were employed to transfer 9.7 mL of culture (each) from the first generation hydrogen-fed bottles (bottles ENV-NC-1,2,3) to bottles containing 40 mL of anaerobic basal media. 0.3 mL of toluene-saturated water (1.8  $\mu\text{moles}$  or 3.3 mg/L) was added to each of three subculture bottles. The toluene-fed bottles were shaken vigorously, 1.8 mL of culture was removed, and 1.8 mL of PCE-saturated water (1.8 to 2.0  $\mu\text{moles}$ ) was added.

All bottles then received 20 mg/L of yeast extract. Cultures were incubated at 35°C and monitored periodically; yeast extract was added routinely. Over a 15-day period, toluene and PCE concentrations remained essentially unchanged. Some methane was detected, likely due to the yeast extract additions. Figure 12 shows PCE and toluene concentrations in one bottle. Replicate bottles performed similarly. Based on these results, toluene would not serve as an electron donor for PCE reduction. However, it is possible that the culture may require acclimation on toluene for a longer period of time.

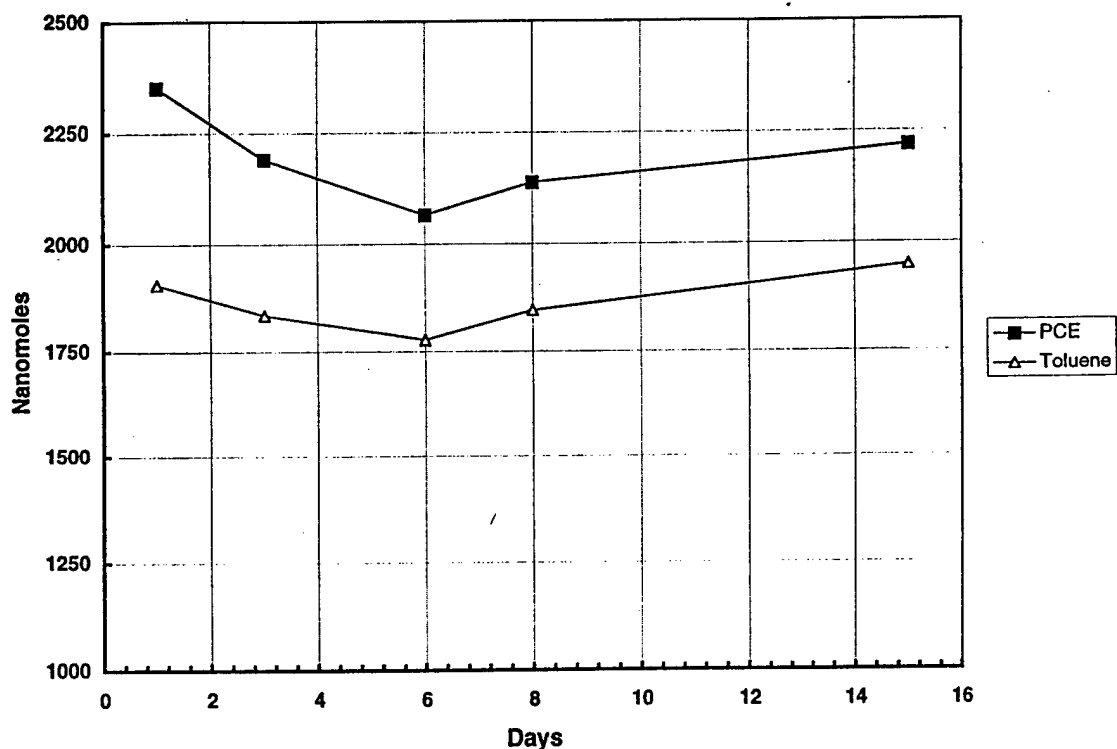

**Figure 12. PCE and Toluene Concentrations in a Second-generation Bottle.**

#### D. THE FATE OF PCE WITHIN THE FBR - $^{14}\text{C}$ [PCE] EXPERIMENTS

Three methods were used to determine the fate of PCE in the bioreactor. The first was the measurement of PCE adsorbed to the GAC at the end of the experiment, and a mass balance comparing the total amount of PCE added to the system with the PCE recovered from the GAC (see Section III.A.5). The second was the measurement of the PCE in the vapor headspace and an estimate of the vapor discharge volume during operation of the system, and a mass balance comparing the total amount of PCE added to the system with the PCE discharged in the vapor (see Section III.A.5). The third was the tracking of radiolabeled carbon after  $^{14}\text{C}$ [PCE] addition.

As stated earlier (Section III.A.4), the PCE removal efficiency, based on liquid GC analyses, was between 90 and 95 percent over the course of the project. Based on a total PCE mass balance, taking into consideration adsorption onto the GAC, an overall PCE removal of 88 percent was observed (2.83 grams of PCE added; 2.49 grams of PCE removed)(see Section III.A.5). The observed loss of PCE was not caused by adsorption onto the glass and stainless steel components of the system; the abiotic loss experiments conducted at the beginning of the project confirmed that the observed loss of PCE can not be attributed to abiotic losses (see Section III.A.1). Based on analyses of the vapor headspace, less than 0.02% of the PCE and TCE added to the system was lost in the form of vapor emissions, and no lesser chlorinated compounds were detected in the off-gas (see Section III.A.5). However, low levels of methane were observed.

The most plausible PCE removal mechanism was biological activity, i.e., anaerobic PCE dechlorination followed by aerobic co-metabolic degradation of TCE, DCE, or vinyl chloride (VC). Evidence of biological PCE and TCE removal is provided by the results of the anaerobic and aerobic bottle assays performed on the reactor culture (see Sections II.C.2 and II.C.3). Evidence of DCE and VC removal is provided by the lack of these compounds in the FBR effluent (Section III.A.4).

Table 6 shows the results of the radiolabeled  $^{14}\text{C}[\text{PCE}]$  experiments. A total of  $2.2 \times 10^8$  dpm of  $^{14}\text{C}[\text{PCE}]$  was added to the FBR system during the experiments, based on a value of 100  $\mu\text{Ci}$  from the manufacturer's specifications and a theoretical dpm/ $\mu\text{Ci}$  ratio of  $2.2 \times 10^6$  for  $^{14}\text{C}$ . Using this value, only 4 percent of the initial radiolabeled carbon added to the system was recovered, and therefore, no conclusions can be made concerning the fate of PCE in the bioreactor from these experiments. Some of the unrecovered  $^{14}\text{C}$  may have been incorporated into cellular components that are not easily extracted from the GAC using methanol. An attempt was made to analyze the GAC directly using the scintillation counter, but interference with the solid GAC particles produced invalid results typically encountered when analyzing solid particles (Jeff Kitzler, National Diagnostics, personal communication). Of the total radiolabeled  $^{14}\text{C}$  recovered, 39% was found in the liquid phase, 56% was extracted from the GAC, and 5% was found in the vapor headspace. Over 99 percent of the radiolabel found in the vapor headspace was in the form of  $^{14}\text{CO}_2$ , and 12 percent of the total recovered radiolabel was in the form of  $^{14}\text{CO}_2$  (vapor plus liquid). The majority (82%) of the radiolabel found in the liquid phase would not easily strip from the liquid with air sparging.

Table 6. Results of Radiolabeled  $^{14}\text{C}$ [PCE] Experiments

Media Analyzed	Average DPM/mL	mL of Media	Total DPM	% of Total DPM Recovered
Liquid Soluble*	620	4,500	$2.8 \times 10^6$	32
Liquid VOCs	0.5	4,500	$2.3 \times 10^3$	<0.1
Liquid $\text{CO}_2$	130	4,500	$5.9 \times 10^5$	7
Solid**	6,580	750	$4.9 \times 10^6$	56
Vapor VOCs	2.2	1,100	$2.4 \times 10^3$	<0.1
Vapor $\text{CO}_2$	350	1,100	$3.9 \times 10^5$	5
Total DPM Recovered			$8.7 \times 10^6$	
Total DPM Added			$2.2 \times 10^8$	

\* Radiolabel that was not stripped from the water after air sparging, determined by subtracting the "Liquid VOCs" DPMs and "Liquid  $\text{CO}_2$ " DPMs from the total liquid DPMs.

\*\* Recovered via methanol extraction.

## E. CULTURE CHARACTERIZATION

### 1. Aerobic Culture

After 14 weeks of operation, samples of GAC were removed from the bioreactor. The carbon samples were shaken vigorously, and the suspended liquid was dilution-plated on BSM-agar. The agar plates were incubated in the presence of toluene vapors for 5 days at  $30^\circ\text{C}$ . Five individual colonies from a total of 5 plates were then transferred to shake flasks containing 100 mL of BSM. The flasks were incubated for 6 to 10 days. During incubation, toluene vapors were supplied to the microorganisms from neat toluene within a glass bulb suspended above the liquid medium. After growth was observed, bottle assays for TCE degradation were performed on the enrichment cultures. These assays were performed using the procedure outlined above in Section II.C.2, except that toluene was added simultaneously with TCE at the beginning of the assay. As seen in Table 7, three of the five colonies tested were capable of degrading TCE at rates comparable to pure *B. cepacia* G4. Figure 13 shows the results from a TCE bottle assay performed on one of the three cultures exhibiting degradative activity.

**Table 7. TCE Assays of Individual Colonies Isolated from the FBR After 14 Weeks**

Culture #	Protein Concentration ( $\mu\text{g/mL}$ )	TCE Degradation Rate (nmoles/minute $\cdot$ mg)
$10^{-3}$ Dilution	400	0.39
$10^{-4}$ Dilution	700	> 0.06*
$10^{-4}$ DUP 'B'	700	0.48
$10^{-5}$ Dilution	>1000	none
$10^{-5}$ DUP 'B'	>1000	none

\* Only two time points were taken for this sample, so an initial degradation rate was not obtained.

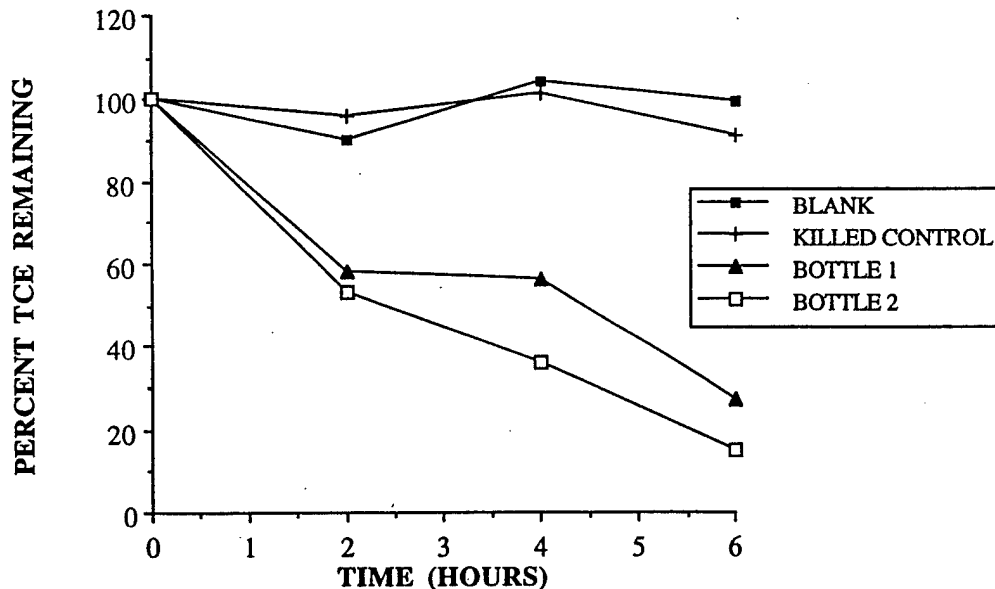

**Figure 13. TCE Bottle Assay for a Pure Culture Isolated from the FBR.** Each bottle contained 10 mL of culture and 10  $\mu\text{L}$  of 40 mM TCE. 10  $\mu\text{L}$  of 400 mM toluene was added to each bottle at time zero. The "killed control" bottle contained 10 mL of culture and 10  $\mu\text{L}$  of 50 mM  $\text{HgCl}_2$ .

## 2. *Anaerobic Culture*

The characteristics of the anaerobic culture isolated from the FBR were investigated by determining the culture's ability to grow under sulfate-reducing, nitrate-reducing, and iron-reducing conditions. A total of 21 sample bottles were prepared - seven (7) for each of the three conditions tested. The basal medium used contained a combination of salts, phosphate buffer, trace metals, and vitamins, similar to the anaerobic basal salts medium (ABSM) described previously (Section II.B.4). The nitrate source for the denitrifying media was provided by the addition of potassium nitrate. The sulfate source for the sulfidogenic media was sodium sulfate. The iron in the iron-reducing media was provided by the addition of a ferric chloride floc. All of the media were boiled and de-oxygenated with  $N_2$  prior to being dispensed into the sample bottles using standard anaerobic procedures developed in Dr. Lily Young's lab at Rutgers University.

Within each set of seven bottles, two killed controls, two background controls, and three experimental bottles were prepared. Each bottle contained 22 mL of media and 3 mL of the anaerobic culture isolated from the bioreactor, which was grown using methanol and later hydrogen as the electron donor for PCE dechlorination. Acetate was provided to act as the electron donor and carbon source for the anaerobic culture characterization experiments. All bottles were prepared using standard anaerobic procedures and were incubated at 30°C for the duration of the experiment.

Samples were taken for analysis from each bottle on the day of preparation (Day 0), and on Day 3 and on Day 6 of incubation. Nitrate and sulfate levels were analyzed to provide evidence of activity under nitrate-reducing and sulfate-reducing conditions. For the iron-reducing growth conditions, the disappearance of acetate and the production of  $Fe^{2+}$  was monitored. No change was expected from Day 0 to Day 3 due to lack of sufficient acetate in all of the bottles. Additional acetate was added to all but the background control bottles prior to sampling on Day 3.

Within the nitrate-reducing set of bottles, complete nitrate disappearance was observed in the three experimental bottles. A small amount of nitrate was also produced. This suggests that a denitrifying population was present in the culture. Although nitrate disappearance was also observed in the "killed" and background controls, the loss of nitrate in the experimental bottles exceeded the loss in the control bottles by 23 percent, and nitrite formation was minimal for the "killed" and background controls. This suggests that a live culture in the experimental bottles had denitrifying capabilities that exceeded the incidental loss in the control bottles. The loss of nitrate in the "killed" controls may be attributed to some live culture remaining in the bottles after autoclaving. The loss of nitrate in the background controls indicates that a carbon source other

than acetate was available in these bottles, perhaps in the form of residual yeast extract transferred with the culture.

No activity (i.e., disappearance of sulfate or reduction of iron) was observed for the sulfate-reducing or the iron-reducing sets. Acetate disappearance occurred in the iron-reducing experimental bottles, but it occurred to the same extent in the controls as well, rendering the data unreliable. Total iron within all of the bottles decreased between 0 and 35 percent. This fluctuation in total iron is not unusual given the possibility for interference by iron floc in the assay method (Dr. Lily Young, personal communication).

The data from the anaerobic bottle assays described earlier (see Section III.C.2) provide strong evidence that the anaerobic culture isolated from the FBR includes a methanogenic population, and data from the anaerobic characterization experiments suggest the presence of a denitrifying population as well. There are no data to support the presence of an iron-reducing or sulfate-reducing population, however. PCE dechlorinating activity was correlated with methane formation during the earlier bottle assay experiments (see Section III.C). PCE dechlorination activity was not determined under denitrifying, sulfate-reducing, or iron-reducing conditions during the anaerobic characterization experiments.

#### IV. CONCLUSIONS

The objective of this Phase I STTR R&D project was to demonstrate and characterize a dual anaerobic/aerobic biofilm process that promotes anaerobic reductive dehalogenation and aerobic cometabolic degradation, simultaneously, in a single bioreactor. A high performance, technically consistent, and low-cost anaerobic/aerobic biological treatment technology would be of great benefit to the Air Force and DOD during the remediation of contaminated groundwater at bases throughout the United States and the world, especially for sites contaminated with a broad range of compounds. The major Phase I goals were to: (1) identify critical parameters which support stable degradative activity; (2) confirm that both anaerobic dehalogenation and aerobic cometabolic degradative activities were occurring simultaneously; and (3) characterize the microbial population.

A laboratory-scale fluidized-bed bioreactor (FBR) was operated under bulk aerobic conditions ( $O_2$  between 0.25 and 3.5 ppm), with the intention of producing anaerobic zones in the interior regions of the biofilm on the support matrix to promote reductive dehalogenation. The FBR system was used as a model to advance the understanding of the dual anaerobic/aerobic process for use in both *in situ* or above-ground applications. PCE, TCE, and BTEX were used as target compounds. TCE is ubiquitous at hazardous and industrial waste sites, and at numerous military facilities. PCE is also frequently found at many AFBs, along with BTEX compounds (from jet fuel, etc.). TCE and BTEX biodegradation can be achieved by aerobic bacteria, whereas PCE biodegradation has only been observed under anaerobic conditions. BTEX compounds can be used as growth substrates. However, no known organism is capable of using TCE as a sole source of carbon and energy. Biological destruction of TCE requires the presence of a co-substrate that acts both as a food source and an inducer to maintain enzymatic activity. TCE can be biodegraded by aerobic bacteria that oxidize toluene (Wackett & Gibson, 1988) and phenol (Folsom et al., 1990), among other co-substrates. For this project, the FBR system was inoculated with *Berkholderia cepacia* G4, an organism known to degrade TCE using toluene as a growth substrate (Folsom et al., 1990).

The results of the project indicate that a dual anaerobic/aerobic biofilm process had been established within the laboratory-scale FBR. Biomass removed from the system showed both reductive dehalogenation activity under anaerobic conditions, and oxidative cometabolic activity under aerobic conditions. A culture obtained from the GAC within the bioreactor contained anaerobes capable of dechlorinating PCE during serum bottle experiments. The anaerobic culture could use methanol or hydrogen as electron donors to reduce PCE. Based on previous work (DiStefano, 1992), it is possible that hydrogen, formed as an intermediate during methanol degradation, was the direct electron donor for the culture. Toluene would not serve as an

electron donor, either directly, or indirectly as a hydrogen precursor. Methanogenesis was the major activity of the anaerobic culture; during bottle assay experiments, methane production accounted for 75 percent of hydrogen use. Additional bottle assay experiments suggested the presence of a denitrifying population as well. Under aerobic conditions, biomass removed from the GAC cometabolically degraded TCE during bottle assays using toluene as a co-substrate. The specific TCE degradation rate was 0.04 to 0.08 nmoles per minute per mg of total protein (nmoles/minute•mg), comparable to rates observed during long-term operation of ENVIROGEN's TCE Gas-phase Bioreactor (GPR) utilizing *Burkholderia cepacia* G4 and phenol as a co-substrate (ENVIROGEN, unpublished results). The specific TCE degradation rates observed for the FBR were between 2 and 7 percent of the specific TCE degradation rate of the pure *B. cepacia* G4 strain used to inoculate the system (1.2 nmoles/minute•mg), which is also typical of previous field experiences. At the end of the project, individual colonies from the GAC were isolated that were capable of growth on toluene. Three of five colonies tested degraded TCE at rates comparable to pure *B. cepacia* G4. In addition to the bottle assay results, no dichloroethene, vinyl chloride, ethene, or ethane were detected in effluent liquid or vapor headspace grab samples from the FBR, providing further support for aerobic cometabolic activity in the bioreactor.

Based on overall PCE and TCE mass balance calculations, taking into consideration adsorption onto the GAC and volatile losses, approximately 90 and 80 percent of the PCE and TCE added to the system was degraded, respectively. These mass balance calculations are conservative. Analyses of influent and effluent liquid grab samples using SW-846 Method 8260 consistently produced higher influent and lower effluent concentrations than were observed using the on-line GC. Part of the reason for the large discrepancy between the on-line and grab sample measurements may be the wide range of concentrations measured using the on-line GC. If the grab sample data are used to adjust the mass balance calculations, then the overall percentage of PCE and TCE degraded by the FBR increase to 98 and 95 percent, respectively. BTEX removal efficiencies were consistently greater than 99 percent during the project.

No firm conclusions can be made concerning the fate of PCE in the bioreactor based on the radiolabeled <sup>14</sup>C[PCE] experiments, since only 4 percent of the initial radiolabeled carbon added to the system was recovered. The experiments should be repeated.

## V. RECOMMENDATIONS

Based on the successful results of the Phase I project, the dual anaerobic/aerobic process should be further developed and tested for treatment of contaminated groundwater. The process is unique in that anaerobic reductive dehalogenation and aerobic biodegradation (both metabolic and cometabolic) occur simultaneously in a single system. Based on the Phase I results, the process is well suited for initial development within a fluidized bed bioreactor (FBR) system. In order to further optimize the FBR process, a deeper understanding of the factors affecting the observed anaerobic/aerobic biological activity is required, and the process must be tested in the field under non-ideal conditions. The information obtained during the field-pilot evaluation should be used to develop cost estimates for using above-ground dual anaerobic/aerobic processes for "pump and treat" applications. Bioreactor performance limitations should be established for treatment of other chlorinated target compounds of interest to the Air Force, such as trichloroethane and chloroform, if the site chosen for the field-pilot test is contaminated with these compounds. In addition, alternative primary substrates for cometabolism should be evaluated, since BTEX contamination may not be present at all sites. Finally, electron donor type and utilization should be optimized, and temperature and shock loading effects should be assessed.

A dual anaerobic/aerobic biofilm process offers the advantage of biodegradation of a range of chlorinated targets in one reactor system, thus reducing capital and operating costs. Although much effort is being invested in development of *in situ* technologies, above-ground reactor systems are often needed for treatment of extracted groundwater from systems employed to provide containment of contaminant plumes. The anaerobic/aerobic FBR biofilm process could serve as such an above-ground treatment system. Also, further investigation of a dual anaerobic/aerobic biofilm system may facilitate its application as an *in situ* bioremediation technology. For example, numerous industrial and hazardous waste facilities exist in which highly chlorinated contaminants exist. Application of anaerobic biotechnology may result in only partial dechlorination, thus necessitating subsequent application of an aerobic process. Based on the results of this project, further investigations may promote the development of *in situ* dual anaerobic/aerobic biofilms with the capability of completely degrading a mixture of contaminants to environmentally acceptable products. Alternatively, a dual anaerobic/aerobic biofilm may find application as an engineered geological barrier, such as a slurry wall. Such a slurry wall could serve as a biologically-active barrier and *in situ* "vessel" for the growth of a dual anaerobic/aerobic biofilm.

## REFERENCES

- Arciero, D.T., T. Vanelli, M. Logan, and A.B Hooper.** 1989. "Degradation of trichloroethylene by the ammonia-oxidizing bacterium *Nitrosomonas europaea*," *Biochem. Biophys. Res. Commun.* 159, 640-643.
- Arvin, E. and P. Harremoes.** 1990. "Concepts and models for biofilm reactor performance," *Wat. Sci. Tech.* 22(1-2), 171-192.
- Brackin, M.J., D.E. McKenzie, B.M. Hughes, and M.A. Heitkamp.** 1996. "Laboratory-scale evaluation of fluidized bed reactor technology for biotreatment of maleic anhydride process wastewater," *J. Industrial Microbiol.* 16, 216-223.
- Dabrock, B., J. Riedel, J. Bertram, and G. Gottschalk.** 1992. Isopropylbenzene (cumene) – a new substrate for isolation of trichloroethylene-degrading bacteria," *Arch Microbiol* 158, 9-13.
- DiStefano, T.D., J.M. Gossett, and S.H. Zinder.** 1991. "Reductive dechlorination of high concentrations of tetrachloroethene to ethene by an anaerobic enrichment culture in the absence of methanogenesis," *Appl. Environ. Microbiol.* 57, 2287-2292.
- DiStefano, T.D., J.M. Gossett, and S. H. Zinder.** 1992. "Hydrogen as an electron donor for dechlorination of tetrachloroethene by an anaerobic mixed culture," *Appl. Environ. Microbiol.* 58, 3622-3629.
- Dobbs, R.A. and J.M. Cohen.** 1980. "Carbon adsorption isotherms for toxic organics," EPA-600/8-80-023. U.S. Environmental Protection Agency, Washington, D.C.
- Ensign, S.A., M.R. Hyman, and D.J. Arp.** 1992. "Cometabolic degradation of chlorinated alkenes by alkene monooxygenase in a propylene-grown *Xanthobacter* strain," *Appl. Environ. Microbiol.* 58, 3038-3046.
- Ensley, B.D.** 1991. "Biochemical diversity of trichloroethylene metabolism," *Ann. Rev. Microbiol.* 56, 283-299.

**Ensley, B.D.** 1992. "Biodegradation of chlorinated hydrocarbons in a vapor phase reactor," DOE/CH-9207. Office of Research and Development, U.S. Department of Energy, Washington, DC.

**Ensley, B.D. and P.R. Kurisko.** 1994. "A gas lift bioreactor for removal of contaminants from the vapor phase," *Appl. Environ. Microbiol.* 60(1), 285-290.

**Enzien, M.V., F. Picardal, T.C. Hazen, R.G. Arnold, and C.B. Fliermans.** 1994. "Reductive dechlorination of trichloroethylene and tetrachloroethylene under aerobic conditions in a sediment column," *Appl. Environ. Microbiol.* 60(6), 2200-2204.

**Ewers, J., Frier-Schroder, and H-J. Knackmuss.** 1990. "Selection of trichloroethylene (TCE) degrading bacteria that resist inactivation by TCE," *Arch. Microbiol.* 154, 410-413.

**Fogel, M.M., A.R. Taddeo, and S. Fogel.** 1986. "Biodegradation of chlorinated ethenes by a methane-utilizing mixed culture," *App. Environ. Microbiol.* 51, 505-511.

**Folsom, B.R., P.J. Chapman, and P.H. Pritchard.** 1990. "Phenol and trichloroethylene degradation by *Pseudomonas cepacia* G4: Kinetics and interactions between substrates," *Appl. Environ. Microbiol.* 56, 1279-1285.

**Folsom, B.R. and P.J. Chapman.** 1991. "Performance characterization of a model bioreactor for the biodegradation of trichloroethylene by *Pseudomonas cepacia* G4," *Appl. Environ. Microbiol.* 57(6), 1602-1608.

**Folsom, B.** 1993. "Liquid-phase bioreactor for degradation of trichloroethylene and benzene," ESL-TR-92. Air Force Civil Engineering Support Agency, Tyndall Air Force Base, FL.

**Folsom, B., P. Kurisko, and B. Ensley.** 1994. "Field demonstration of vapor phase TCE bioreactor," DOE/OR/21400-T492. U.S. Department of Energy, Washington, DC.

**Fox, B.G., J.G. Borneman, L.P. Wackett, and J.D. Lipscomb.** 1990. "Haloalkene oxidation by the soluble methane monooxygenase from *Methylosinus trichosporium* OB3b: Mechanistic and environmental implications," *Biochemistry* 29, 6419-6427.

**Guarini, B. and B. Folsom.** 1996. "Liquid-phase bioreactor for degradation of trichloroethylene and benzene," AL/EQ-TR-1995-0001. Air Force Materiel Command, Tyndall Air Force Base, FL.

**Kazumi, J., M.M. Haggblom, and L.Y. Young.** 1995. "Degradation of monochlorinated and nonchlorinated aromatic compounds under iron-reducing conditions," Appl. Environ. Microbiol. 61(11), 4069-4073.

**Klecka, G.M., S.G. McDaniel, P.S. Wilson, C.L. Carpenter, and J.E. Clark.** 1995. "Field evaluation of an Envirex GAC fluid-bed bioreactor for treatment of chlorobenzene in groundwater," AL/EQ-TR-1994-0047. Air Force Materiel Command, Tyndall Air Force Base, FL.

**Little, C.D., A.V. Palumbo, S.C. Herbes, M.E. Lidstrom, R.L. Tyndall, and P.J. Gilmer.** 1988. "Trichloroethylene biodegradation by a methane-oxidizing bacterium," Appl. Environ. Microbiol. 54(4), 951-956.

**Lovley, D.R. and E.J.P. Phillips.** 1986. "Organic matter mineralization with reduction of ferric iron in anaerobic sediments," Appl. Environ. Microbiol. 51(4), 683-689.

**Mackay, D. and W.Y. Shiu.** 1981. "Critical review of Henry's law constants for chemicals of environmental interest," J. Phys. Chem. Ref. Data 10(4), 1175-1199.

**Massol-Deya, A.A., J. Whallon, R.F. Hickey, and J.M. Tiedje.** 1995. "Channel structures in aerobic biofilms of fixed-film reactors treating contaminated groundwater," Appl. Environ. Microbiol. 61(2), 769-777.

**Miller, R.E. and F.T. Guengerich.** 1983. "Metabolism of trichloroethylene in isolated hepatocytes, microsomes, and reconstituted enzyme systems containing P-450," Cancer Research 43, 1145-1152.

**Oldenhuis, R., J.Y. Oedzes, J.J. van der Waarde, and D.B. Janssen.** 1991. "Kinetics of chlorinated hydrocarbon degradation by *Methylosinus trichosporium* OB3b and toxicity of trichloroethylene," App. Environ. Microbiol. 57, 7-14.

**Radian International.** 1996. "2-phase extraction and gas-phase bioreactor treatment of TCE in soil and groundwater - F.E. Warren AFB, Wyoming." Prepared for Air Force Center for Environmental Excellence, Brooks Air Force Base, TX.

**Sewell, G.W. and S.A. Gibson.** 1991. "Stimulation of the reductive dechlorination of tetrachloroethene in anaerobic aquifer microcosms by the addition of toluene," Environ. Sci. Technol. 25, 982-984.

**Shi, J., X. Zhao, R.F. Hickey, and T.C. Voice.** 1995. "Role of adsorption in granular activated carbon-fluidized bed reactors," Water Env. Res. 67(3), 302-309.

**Sommerfield, T. and T. Locheed.** 1992. "Hungry microorganisms devour methylene chloride," Chemical Processing 55(3), 40-42.

**Sorenson, J.** 1982. "Reduction of ferric iron in anaerobic, marine sediment and interaction with reduction of nitrate and sulfate," Appl. Env. Microbiol. 43(2), 319-324..

**Sutton, P.M. and P.N. Mishra.** 1994. "Activated carbon based biological fluidized beds for contaminated water and wastewater treatment: a state-of-the-art review," Wat. Sci. Tech. 29(10-11), 309-317.

**Vogel, T.M. and P. McCarty.** 1985. "Biotransformation of tetrachloroethylene to trichloroethylene, dichloroethylene, vinyl chloride and carbon dioxide under methanogenic conditions," Appl. Env. Microbiol. 49, 1080-1083.

**Wackett, L.P. and D.T. Gibson.** 1988. "Degradation of trichloroethylene by toluene dioxygenase in whole cell studies with *Pseudomonas putida F1*," App. Environ. Microbiol. 54, 1703-1708.

**Wackett, L.P., G.A. Brusseau, S.R. Householder, and R.S. Hanson.** 1989. "Survey of microbial oxygenases: trichloroethylene degradation by propane-oxidizing bacteria," Appl. Environ. Microbiol. 55, 2960-2964.

**Zeikus, J.G.** 1977. "The biology of methanogenic bacteria," Bacteriological Reviews 41, 514-541.