

REPORT DOCUMENTATION PAGE

Form Approved
OMB No 0704-0188

Public reporting burden for this collection of information is estimated to average 1 hour per response, including the time for reviewing instructions, searching existing data sources, gathering and maintaining the data needed, and completing and reviewing the collection of information. Send comments regarding this burden estimate or any other aspect of this collection of information, including suggestions for reducing this burden, to Washington Headquarters Services, Directorate for Information Operations and Reports, 1215 Jefferson Davis Highway, Suite 1204, Arlington, VA 22202-4302, and to the Office of Management and Budget, Paperwork Reduction Project (0704-0188), Washington, DC 20503.

1. AGENCY USE ONLY (Leave blank) 2. REPORT DATE November 1997 3. REPORT TYPE AND DATES COVERED Final - 1 Oct 94 - 30 Sep 97

4. TITLE AND SUBTITLE Percutaneous Absorption of Volatile Chemicals 5. FUNDING NUMBERS AFOSR G F49620-95-1-0017 2312-AS 61102F

6. AUTHOR(S) Riviere JE, Brooks JD, Qiao GL, Monteiro-Riviere NA

7. PERFORMING ORGANIZATION NAME(S) AND ADDRESS(ES) Cutaneous Pharmacology and Toxicology Center North Carolina State University Raleigh, NC 27606 8. PERFORMING ORGANIZATION REPORT NUMBER AFOSR-TR 97-0704

9. SPONSORING / MONITORING AGENCY NAME(S) AND ADDRESS(ES) AFSOR/NL 110 Duncan Avenue, Room B115 BollingAFB, DC 20332-8080 10. SPONSORING / MONITORING AGENCY REPORT NUMBER 19971217 062

11. SUPPLEMENTARY NOTES

12a. DISTRIBUTION / AVAILABILITY STATEMENT Approved for public release; distribution unlimited. 12b. DISTRIBUTION CODE

13. ABSTRACT (Maximum 200 words)
The purpose of this project was to assess the percutaneous absorption of two volatile organic compounds, chloropentafluorobenzene (CPF) and dichlorobenzene (DCB) in the isolated perfused porcine skin flap (IPPSF) model. An independent theoretical goal was to begin to develop a mathematical framework to assess vehicle-compound interactions which occur during dermal exposure. Assessment of the percutaneous absorption and penetration of volatile compounds is difficult. The process of studying these compounds involved 5 steps: (1) development of an IPPSF cradle chamber to trap the evaporated compound in the area next to the skin, (2) assessment of the mass of CPF that was absorbed into the perfusate from CPF which was evaporated from excised skin, (3) exposure of the IPPSF to neat test compounds and test compounds in a vehicle, (4) assessment of the mass of the test compound in the perfusate as a result of exposure to the volatile compound vapor, and (5) development of a dosing dome that allowed dosing a vapor without vapor uptake directly into the perfusate. Relevant absorption parameters were then determined. These studies demonstrated dose-dependent absorption of CPF and DCB in skin which was further modulated by concomitant exposure to vehicle. The data obtained could be used as direct input into a systemic risk assessment model.

14. SUBJECT TERMS Percutaneous Absorption, IPPSF, CPF, DCB 15. NUMBER OF PAGES 16. PRICE CODE

17. SECURITY CLASSIFICATION OF REPORT U 18. SECURITY CLASSIFICATION OF THIS PAGE U 19. SECURITY CLASSIFICATION OF ABSTRACT U 20. LIMITATION OF ABSTRACT (U)

INTRODUCTION

The skin is a primary portal of entry for toxic compounds. Of relevance to the AirForce, this includes volatile components of aviation fuels. Most risk assessment studies of these compounds have been focused on inhalational exposure. Minimal studies have been conducted on assessing their absorption after dermal exposure. A physiological-based pharmacokinetic approach has been described in rodents (McDougal et al., 1985, 1986). The two model compounds selected in this study were chloropentafluorobenzene (CPFEB) and dichlorobenzene (DCB).

Our laboratory had previously developed an isolated perfused porcine skin flap (IPPSF) model to quantitatively assess the percutaneous absorption of topically applied chemicals (Bowman et al., 1991; Monteiro-Riviere et al., 1987; Riviere et al., 1986, 1991, 1995b). These references should be consulted for a complete description of experimental techniques. Studies of topically applied chemicals clearly demonstrated the utility of this model (Carver et al., 1989; Chang et al., 1994; Riviere et al., 1995a) and a close correlation to *in vivo* absorption in animals and man (Heit et al., 1993; Riviere et al., 1991, 1992, 1995b; Williams et al., 1990). Of significance to this project, we also demonstrated significant effects of coadministered solvents and other components of topically applied mixtures which significantly altered absorption of marker toxicants (Baynes et al., 1996, 1997; Brooks and Riviere, 1996; Qiao et al., 1996; Williams et al., 1996). These findings led to the inclusion of assessing solvent effect on neat vapor absorption in the present study. Finally, efforts have been made to develop physiologically and biophysically relevant dermatopharmacokinetic models to quantitate chemical penetration and absorption in the IPPSF (Carver et al., 1989; Chang et al., 1994; Riviere et al., 1995a, 1995b; Williams et al., 1990, 1995). The initial results of the work from the present agreement has been published as it applies to modeling absorption interactions in topical mixtures (Williams et al., 1996).

The primary challenge to the present investigations was the adaptation of the IPPSF model system to study volatile chemical absorption. To accomplish this goal, we custom designed the IPPSF cradle chamber illustrated in Figure 1 to conduct these studies. This cradle chamber allows the volatile compound to evaporate and be trapped in an occlusive environment around the skin flap. We sampled the vapor for the test compound in the cradle chamber as illustrated in Figure 2 sample port A. Perfusate samples were collected in the normal fashion from sample port B. All samples were assayed via gas chromatography (GC) for test compound concentration. Because the compound vapor is in contact with the perfusate as it exits the IPPSF, higher perfusate values were obtained than what was actually absorbed through the skin. We were able to ascertain the amount of test compound contributed by the vapor via direct contact with the perfusate. This value was subtracted to estimate the actual absorption values of the test compounds. A glass dosing dome was then developed to eliminate the necessity of normalization by the vapor effect. The shape of the test compound profiles from this glass dosing dome are very similar to the corrected perfusate minus the vapor effect. The compounds were tested neat and with varying concentrations of vehicles. We chose ethanol as the vehicle for the DCB experiments, but it was necessary to use acetone for the vehicle in the CPFEB experiments because of analytical interference since the elution times of ethanol and CPFEB are at similar times during GC analysis. The primary accomplishment of this research was the

Figure 1

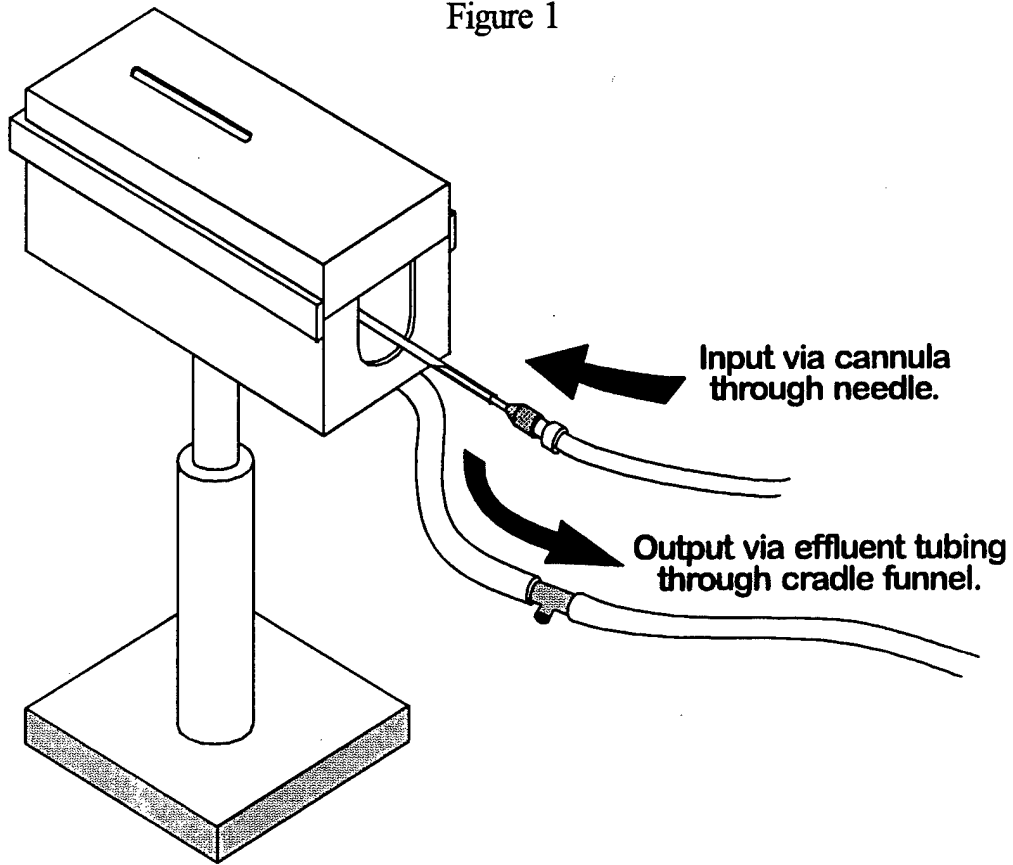
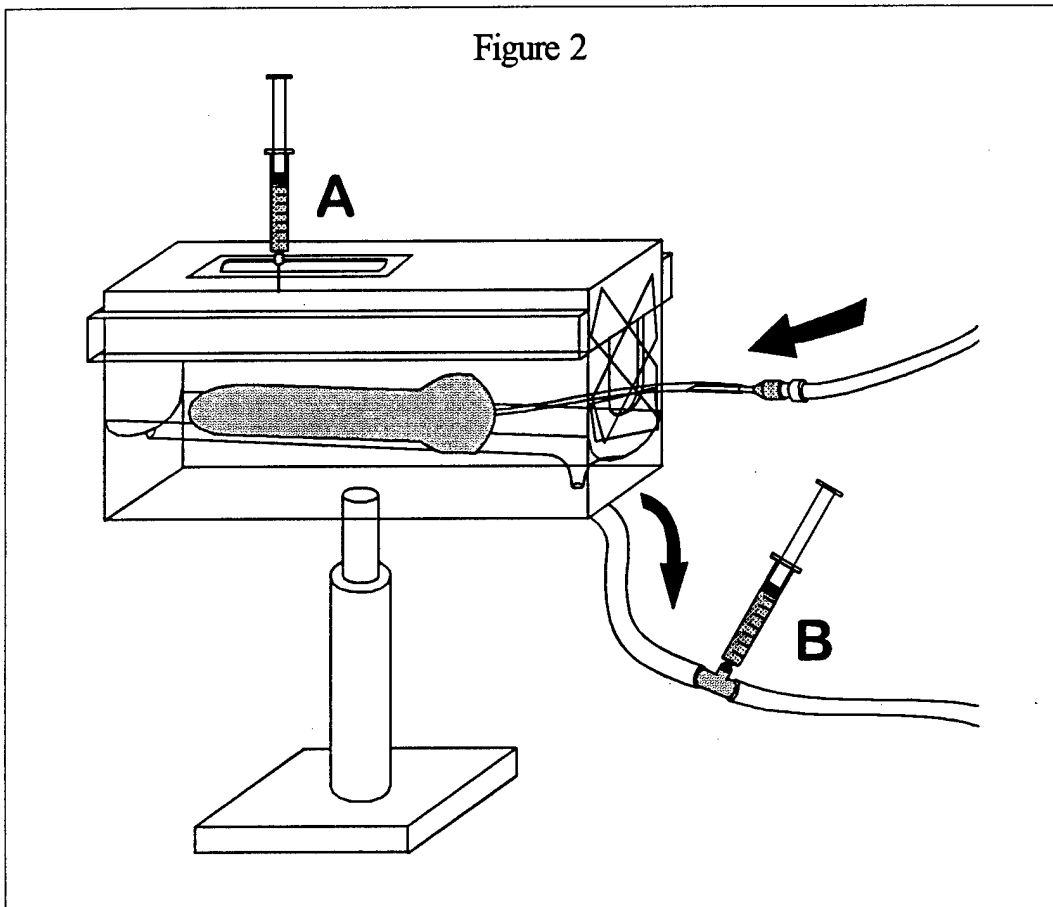

Figure 2



development of this experimental approach to study the absorption of volatiles in the IPPSF. This technology will be used in future research aimed at assessing the absorption and toxicology of chemical vapors. Complete absorption and cutaneous disposition parameters were then calculated.

MATERIALS AND METHODS

The IPPSF procedure has been documented extensively elsewhere (Bowman et al., 1991; Monteiro-Riviere et al., 1987; Riviere et al., 1986, 1991, 1995b). A 1 cm x 3 cm dosing area was drawn on the surface of the skin flap with a surgery marker. The cradle chamber was then secured in place with a parafilm gasket. The cannula end of the cradle was sealed to minimize evaporation from the cradle chamber (See Figure 2). The skin flap was dosed via the slit in the top of the cradle chamber and the slit was immediately sealed with tape. Vapor samples were taken from this slit via 25 gauge needle through the tape and the hole in the tape was resealed immediately after sampling. Care was taken at every step to minimize loss of the test compound vapor.

CPF_B is considerably more volatile than DCB. The CPF_B evaporated to fill the cradle chamber almost immediately, while the DCB "beaded" on the surface of the skin and ran off the sides of the skin flap as illustrated by the end view of the skin flap and cradle in Figure 3-A. We have used a Stomahesive® template in the past, but never with a dose as small as 20 µl. Figure 3-B shows the effect of the curved surface of the skin flap on the dose that is trapped by a dosing template. Note that an indeterminate volume of the dose is unavailable for absorption because it is in contact with the dosing template and not the skin. This suggests a significant limitation to this approach.

The lower volatility and less than ideal template encouraged the development of the glass dosing dome, illustrated in Figure 4, for application of vapors of volatile test compounds. The glass dosing dome was developed in conjunction with the glass shop on NCSU campus. The glass dome is placed over the skin flap and the snugness of the fit holds the dome in place. Several sizes of custom-blown glass dosing domes have been developed to accommodate various skin flap sizes. Although care is taken to produce skin flaps that are the same length and diameter, due to differences in donor pigs and surgical procedures, it is impossible to produce absolutely uniform-sized skin flaps. No adhesives are necessary. The ground glass stopper is removed from the glass dosing dome and the dose of the volatile test compound is applied to the porous ground glass frit at the base of the central tube. The glass stopper is replaced immediately after pipetting the dose. The test compound then volatilizes to fill the dome with test compound vapor. Because the glass dosing dome eliminates direct contact of the vapor with the perfusate, the test compound that appears in the perfusate is now due to absorption through the skin.

At termination, several samples were taken for mass balance of the test compounds. The cradle chamber tape and parafilm was saved for extraction, or the test compound was rinsed from the glass dosing dome, depending upon the dosing apparatus. The surface of the dose area was swabbed twice with a 1% soap solution and gauze, and followed by 12 stratum corneum tape strips. The entire dose area was removed. A 1 cm x 1 cm core of the dose area was removed, quick-frozen in a liquid nitrogen cooled isopentane well and cyrosectioned for subsequent depth of penetration studies (See Brooks and Riviere, 1996; Monteiro-Riviere et al., 1993). The

Figure 3

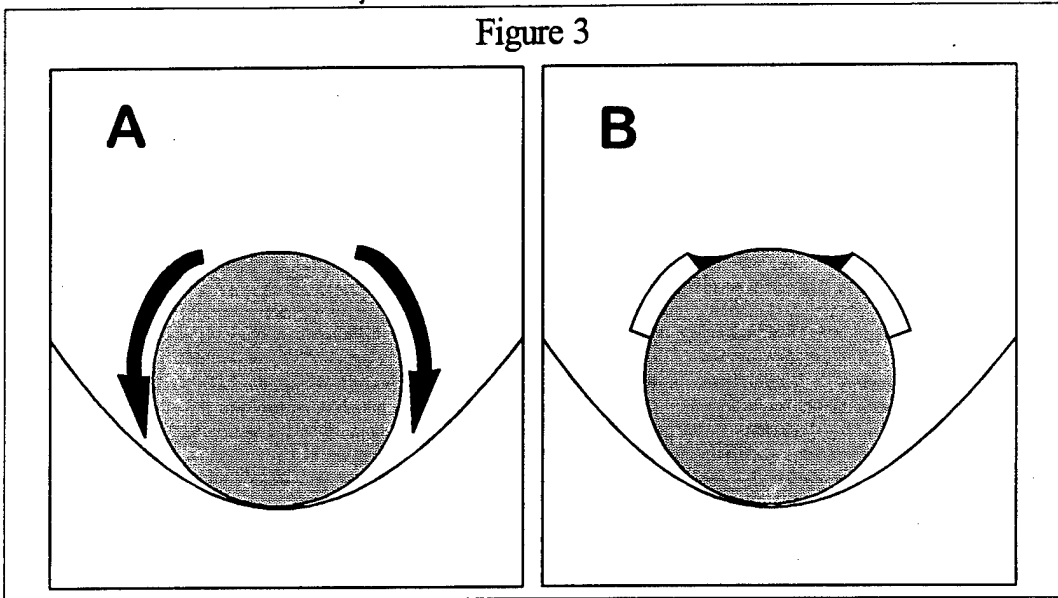
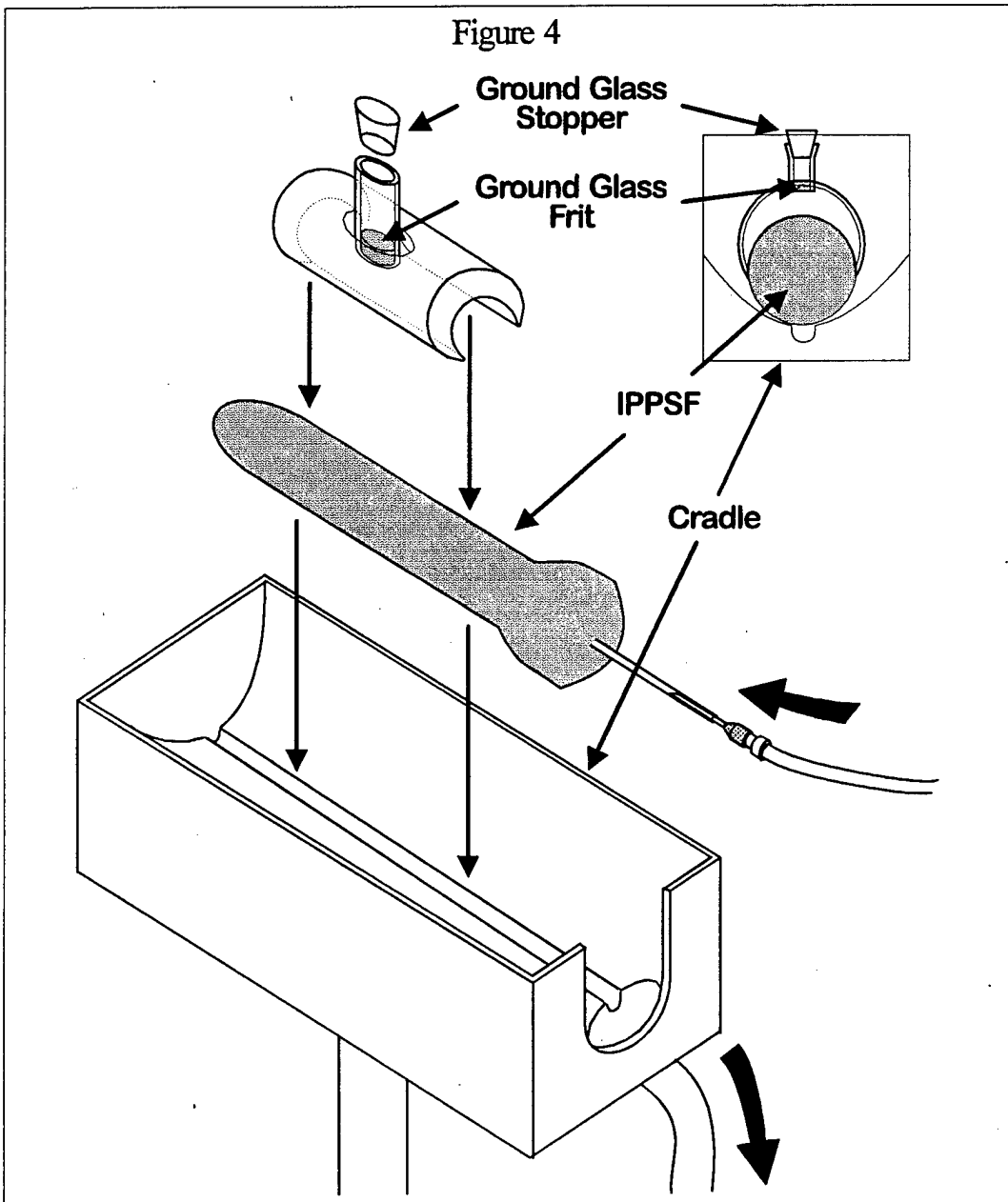

Figure 4



remaining dose area and a sample of the fat under the dose area was extracted with the appropriate solvent and analyzed for test compound. A 1 cm x 1 cm area of non-dosed skin was extracted and analyzed. The cutting board, razor blade, cradle and fingertips of the gloves were rinsed, extracted and analyzed. Sample analysis was via gas chromatography. The Hewlett Packard 5890 II Gas Chromatograph conditions:

Column:	Alltech Capillary Column SE-30 15 m x 0.53 mm.
Detector:	ECD.
Carrier gas:	95% argon/5% methane.
Total flow rate:	~58 ml/min.
Oven temperature:	70°C.
Injector temperature:	180°C.
Detector temperature:	380°C.
Column Flow rate:	10 ml/min.
Total flow (Column + Aux):	60 ml/min.

Extraction of CPFB samples was via hexane, DCB via isooctane. The CPFB and DCB samples were quantified using the external standard method.

The correction of the perfusate samples for the vapor effect was accomplished by the normalization procedure as follows:

- 1) Determine $\mu\text{g/ml}$ concentrations in Vapor and Perfusate samples.
- 2) Determine Ratio $[\text{Perfusate}(\mu\text{g/ml})/\text{Vapor}(\mu\text{g/ml})]$.
- 3) Determine first plateau of Ratios = Ratio*.
- 4) Determine Corrected Perfusate using the equations:
Ratio* = $[\text{Perfusate}/\text{Vapor}]$
Perfusate = $(\text{Ratio}^* \times \text{Vapor})$
Corrected Perfusate₀₋₁₂₀ = $[\text{Original Perfusate}_{0-120} - (\text{Ratio}^* \times \text{Vapor}_{0-120})]$

RESULTS

Table 1 lists the experiments we conducted with CPFB and DCB that were employed in these analyses. Additional experiments were conducted throughout the grant period however data were not used either because of inadequate IPPSF performance or early development of volatile exposure protocols.

Preliminary CPFB evaporation studies were conducted in the cradle chamber with 500 μm thick excised pig skin stretched over a cylinder having the approximate diameter of the IPPSF. A dose of 20 μl neat CPFB was applied to the excised skin. The same cannula material used in the IPPSF delivered the normal perfusate at the same rate into the bottom of the cradle.

Table 1

AFOSR Experiments 1996 and 1997 Fiscal Years.

Total Exp.	Exp. per Year	Exp. per Fisc.							
1	1	1	Evap1	11/15/95	CPFB	Cradle Chamber	20 ul neat		Evaporation
2	2	2	Evap2	11/15/95	CPFB	Cradle Chamber	20 ul neat		Evaporation
3	3	3	Evap3	11/16/95	CPFB	Cradle Chamber	20 ul neat		Evaporation
4	4	4	Evap4	11/16/95	CPFB	Cradle Chamber	20 ul neat		Evaporation
5	1	1	2164	1/26/96	CPFB	Cradle Chamber	20 ul neat		topical liquid
6	2	2	2165	1/26/96	CPFB	Cradle Chamber	20 ul neat		topical liquid
7	3	3	2166	2/2/96	CPFB	Cradle Chamber	20 ul neat		topical liquid
8	4	4	2167	2/2/96	CPFB	Cradle Chamber	20 ul neat		topical liquid
9	5	5	2170	2/9/96	CPFB	Nonoccluded	20 ul neat		topical liquid
10	6	6	2171	2/9/96	CPFB	Nonoccluded	20 ul neat		topical liquid
11	7	7	2174	2/16/96	CPFB	Nonoccluded	20 ul neat		topical liquid
12	8	8	2175	2/16/96	CPFB	Nonoccluded	20 ul neat		topical liquid
13	9	9	2180	2/23/96	CPFB	Occluded	20 ul neat		topical liquid
14	10	10	2181	2/23/96	CPFB	Occluded	20 ul neat		topical liquid
15	11	11	2182	3/1/96	CPFB	Occluded	20 ul neat		topical liquid
16	12	12	2183	3/1/96	CPFB	Occluded	20 ul neat		topical liquid
17	13	13	2196	4/19/96	CPFB	Cradle Chamber	20 ul neat		topical liquid
18	14	14	2197np	4/19/96	CPFB	Cradle Chamber	20 ul neat		topical liquid
19	15	15	2198	4/26/96	CPFB	Cradle Chamber	20 ul neat		topical liquid
20	16	16	2199	4/26/96	CPFB	Cradle Chamber	20 ul neat		topical liquid
21	17	17	2202	5/3/96	CPFB	Cradle Chamber	2 ul neat		topical liquid
22	18	18	2203	5/3/96	CPFB	Cradle Chamber	2 ul neat		topical liquid
23	19	19	2206	5/10/96	CPFB	Cradle Chamber	2 ul neat		topical liquid
24	20	20	2207	5/10/96	CPFB	Cradle Chamber	2 ul neat		topical liquid
25	21	21	2212	5/17/96	CPFB	Cradle Chamber	2 ul CPFB:8 ul Acetone		topical liquid
26	22	22	2213	5/17/96	CPFB	Cradle Chamber	2 ul CPFB:8 ul Acetone		topical liquid
27	23	23	2214	5/24/96	CPFB	Cradle Chamber	2 ul CPFB:8 ul Acetone		topical liquid
28	24	24	2215	5/24/96	CPFB	Cradle Chamber	2 ul CPFB:8 ul Acetone		topical liquid
29	25	25	2218	5/31/96	CPFB	Cradle Chamber	10 ul CPFB:10 ul Acetone		topical liquid
30	26	26	2219	5/31/96	CPFB	Cradle Chamber	10 ul CPFB:10 ul Acetone		topical liquid
31	27	27	2222	6/14/96	CPFB	Cradle Chamber	10 ul CPFB:10 ul Acetone		topical liquid
32	28	28	2223	6/14/96	CPFB	Cradle Chamber	10 ul CPFB:10 ul Acetone		topical liquid
33	29	29	2235	7/12/96	CPFB	Cradle Chamber	20 ul neat		topical liquid
34	30	30	2234np	7/12/96	CPFB	Cradle Chamber	20 ul neat		topical liquid
35	31	1	2236	10/3/96	DCB	Cradle Chamber	20 ul neat		topical liquid
36	32	2	2237	10/3/96	DCB	Cradle Chamber	20 ul neat		topical liquid
37	33	3	2238	10/4/96	DCB	Cradle Chamber	20 ul neat		topical liquid
38	34	4	2239	10/4/96	DCB	Cradle Chamber	20 ul neat		topical liquid
39	35	5	2246	12/11/96	DCB	Cradle Chamber	20 ul neat		topical liquid
40	36	6	2247	12/11/96	DCB	Cradle Chamber	20 ul neat		topical liquid
41	1	7	2252	1/22/97	CPFB	Dosing Dome	20 ul neat		vapor dose from glass frit
42	2	8	2254	1/23/97	CPFB	Dosing Dome	20 ul neat		vapor dose from glass frit
43	3	9	2255	1/23/97	CPFB	Dosing Dome	20 ul neat		vapor dose from glass frit
44	4	10	2256	2/5/97	CPFB	Dosing Dome	20 ul neat		vapor dose from glass frit
45	5	11	2257	2/5/97	CPFB	Dosing Dome	20 ul neat		vapor dose from glass frit
46	6	12	2258	2/6/97	CPFB	Dosing Dome	20 ul neat		vapor dose from glass frit
47	7	13	2259	2/6/97	CPFB	Dosing Dome	20 ul neat		vapor dose from glass frit
48	8	14	2276	6/4/97	DCB	Dosing Dome	20 ul neat		vapor dose from glass frit
49	9	15	2277	6/4/97	DCB	Dosing Dome	20 ul neat		vapor dose from glass frit
50	10	16	2278	6/5/97	DCB	Dosing Dome	20 ul neat		vapor dose from glass frit
51	11	17	2279	6/5/97	DCB	Dosing Dome	20 ul neat		vapor dose from glass frit
52	12	18	2280	6/18/97	DCB	Dosing Dome	50 ul neat		vapor dose from glass frit
53	13	19	2281	6/18/97	DCB	Dosing Dome	50 ul neat		vapor dose from glass frit
54	14	20	2282	6/19/97	DCB	Dosing Dome	50 ul neat		vapor dose from glass frit
55	15	21	2283	6/19/97	DCB	Dosing Dome	50 ul neat		vapor dose from glass frit
56	16	22	2285	6/25/97	DCB	Dosing Dome	10 ul DCB:10 ul Ethanol		vapor dose from glass frit
57	17	23	2286	6/26/97	DCB	Dosing Dome	10 ul DCB:10 ul Ethanol		vapor dose from glass frit
58	18	24	2287	6/26/97	DCB	Dosing Dome	10 ul DCB:10 ul Ethanol		vapor dose from glass frit
59	19	25	2295	10/1/97	DCB	Dosing Dome	20 ul DCB:20 ul Ethanol		vapor dose from glass frit
60	20	26	2297	10/2/97	DCB	Dosing Dome	20 ul DCB:20 ul Ethanol		vapor dose from glass frit

The CPFVB vapor which volatilized from the skin surface was in contact with the perfusate. Figure 5-A illustrates the mean CPFVB vapor values and Figure 5-B the mean perfusate concentrations in the cradle chamber over time from excised non-perfused skin. Because there is no penetration through the excised skin into the perfusate, this data demonstrates the uptake of CPFVB vapor by the perfusate and the need to normalize any perfusate absorption in IPPSFs to this confounding factor.

The first 12 IPPSF experiments were conducted to determine the validity of the cradle chamber. Four cradle chamber skin flaps were compared to four nonoccluded and four occluded skin flaps perfused in the normal IPPSF apparatus. CPFVB was so volatile that absorption and recoveries were minimal with the nonoccluded system. The occluded system (3 cm x 5 cm cellophane tape applied over dose) produced similar penetration and distribution results to the cradle chamber, but was discarded due to the unnatural situation of the procedure (e.g. interactions with the tape; non-similarity to field exposures). Figure 6-A illustrates the mean CPFVB vapor values in the cradle chamber, the nonoccluded system, and the occluded system over time in the IPPSF. Vapor samples were taken from the area over the IPPSF on the non-occluded and occluded systems. The absence of CPFVB in the IPPSF chamber demonstrates the volatility of the CPFVB and the effectiveness of the occlusion device. Figure 6-B illustrates the mean CPFVB perfusate values over time for the same experiments. This perfusate data demonstrates the trace amounts of absorbed CPFVB from a nonoccluded system. The lack of CPFVB in the vapor samples under occluded dosing supports the efficiency of the occlusion process.

Figure 7-A illustrates the mean vapor levels of CPFVB inside the cradle chamber over time for four different dosing protocols. Figure 7-B illustrates the mean CPFVB values in the perfusate before removal of the vapor effect. Figure 7-C illustrates the ratio of perfusate/vapor CPFVB levels. The steady state plateau of this ratio multiplied by the vapor levels of CPFVB inside the cradle chamber quantitates the vapor contribution to the perfusate concentrations. This vapor contribution was subtracted from the perfusate CPFVB values in Figure 7-B to yield Figure 7-D. Figure 7-E compares the occluded CPFVB absorption profile in Figure 6-B to the corrected absorption profile in Figure 7-D. It is significant that the second hour absorption values are similar, although it also illustrates that the correction process prohibits one from studying the early phase of absorption. Figure 8-A, -B, -C, and -D are the same plots for DCB as Figure 7-A-D. Only one DCB dosing protocol was tested within the cradle chamber since these studies were done after we detected the confounding vapor effect with CPFVB and discarded this experimental approach. Note there was very little vapor effect on DCB absorption and no clear-cut plateau equilibrium as was seen with CPFVB. This is due to DCB's lower volatility. All corrections were performed on an individual basis using individual skin flap data, but mean values are reported here.

Figures 9-A and 10-A illustrate the absorption of CPFVB and DCB respectively through the skin flap from the glass dosing dome illustrated in Figure 4. Figures 9-B and 10-B compare the dosing dome profiles to the cradle chamber profiles seen in Figures 7-D and 8-D respectively. The glass dosing dome traps the vapor next to the skin flap eliminating the vapor effect above. Notice in Figure 10-A that there has been no depletion of the DCB dose since no defined peak has been demonstrated.

Figures 11-A and 12-A illustrate mass residues at termination time of CPFVB and DCB respectively. Figures 11-B and 12-B illustrate the same data reported in percentage of dose.

Figure 5

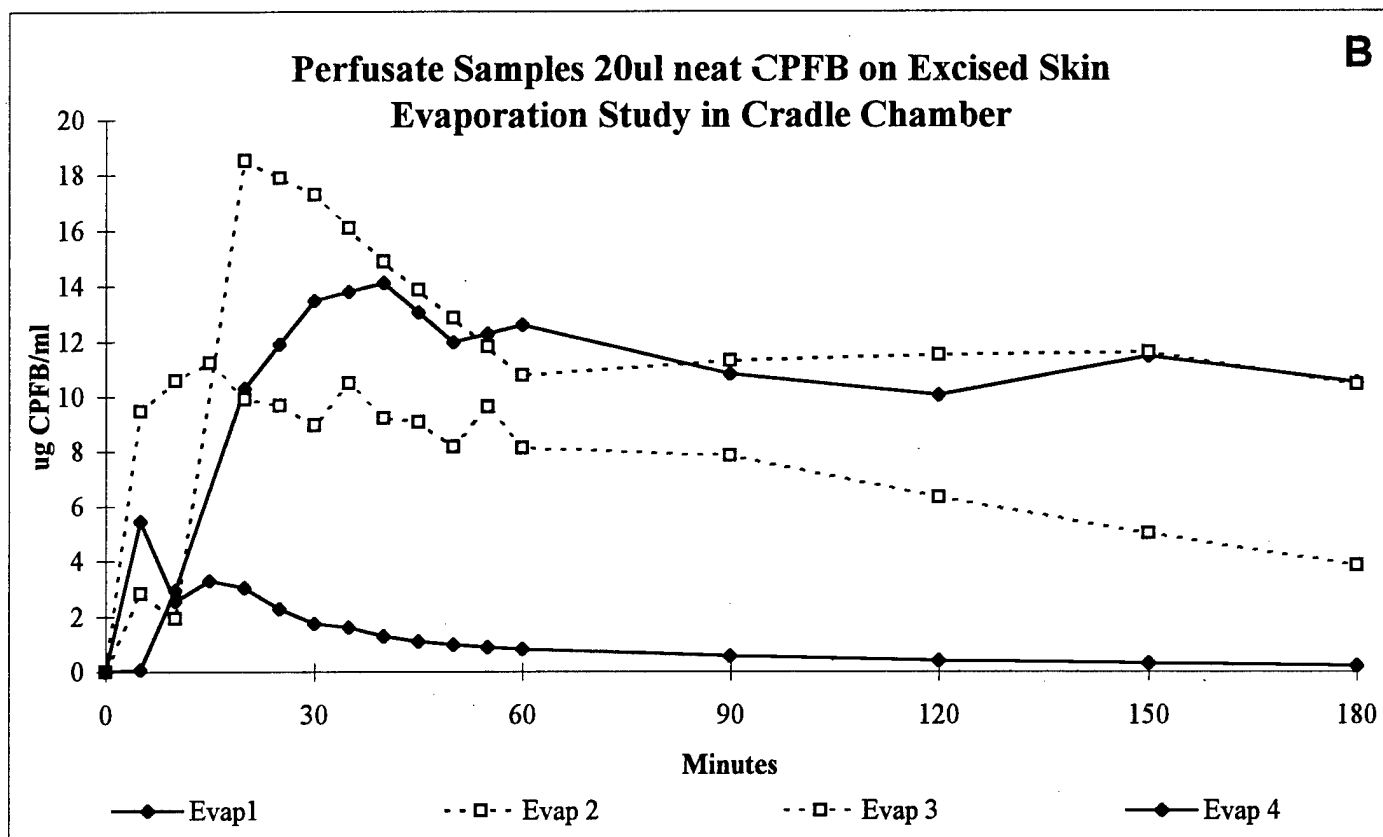
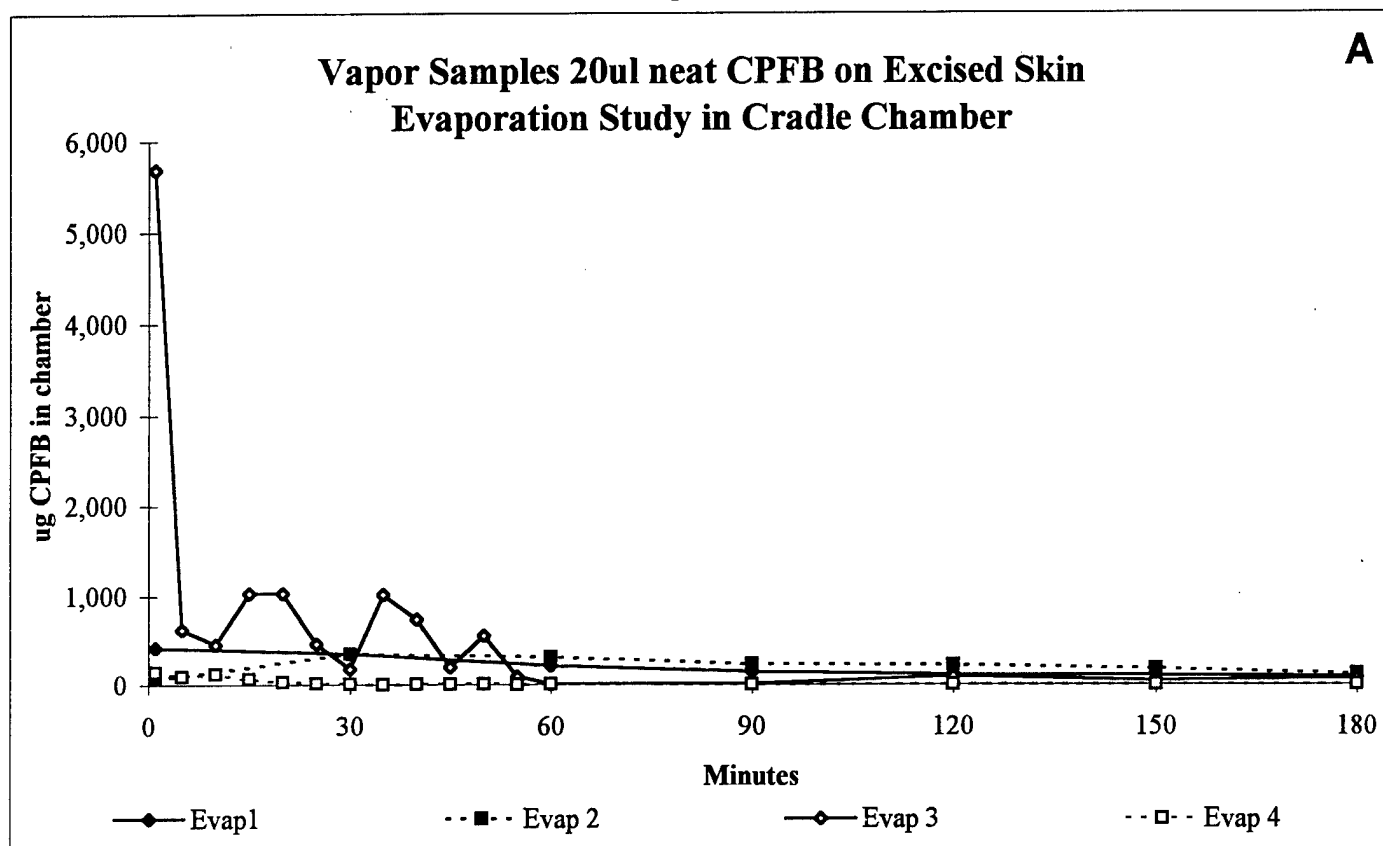

Figure 6

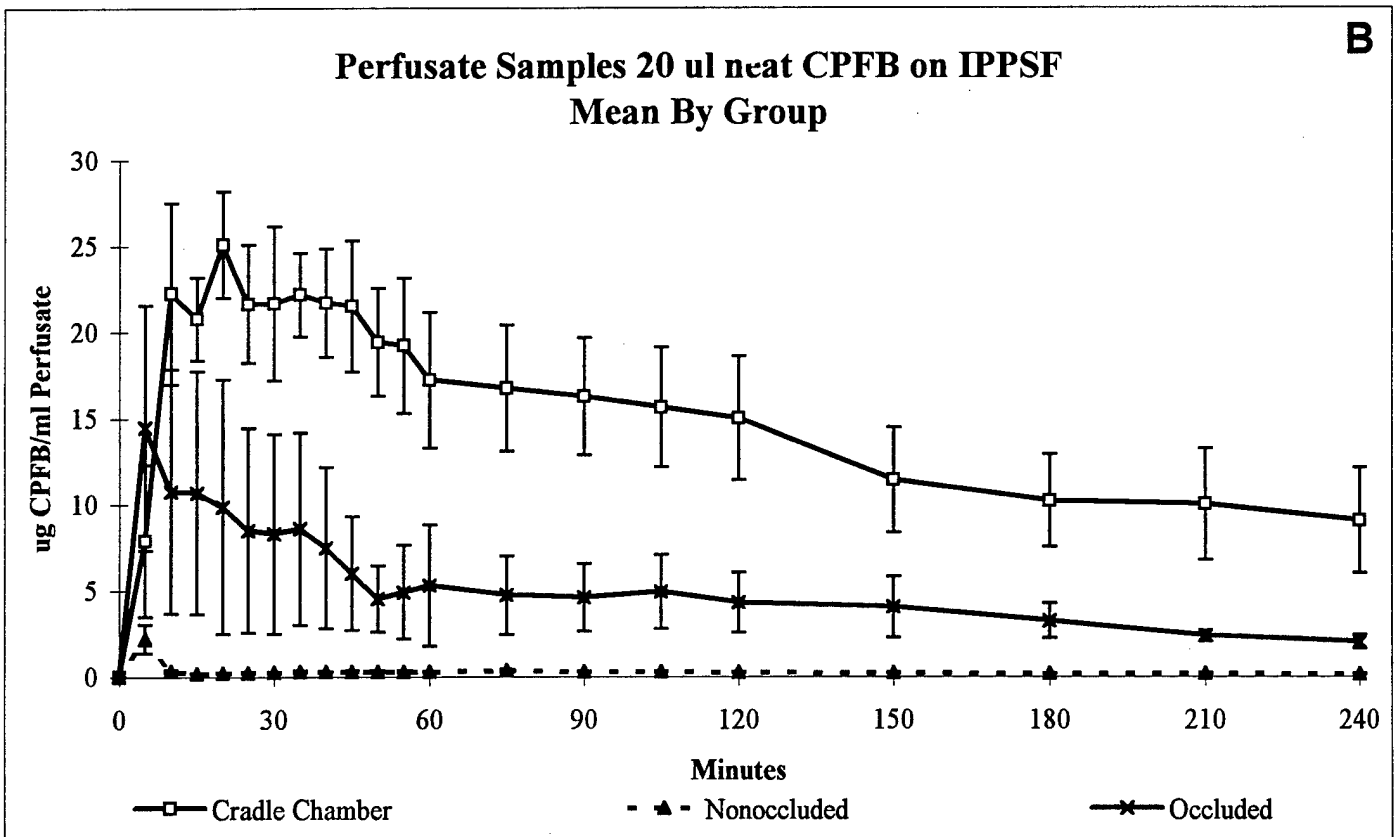
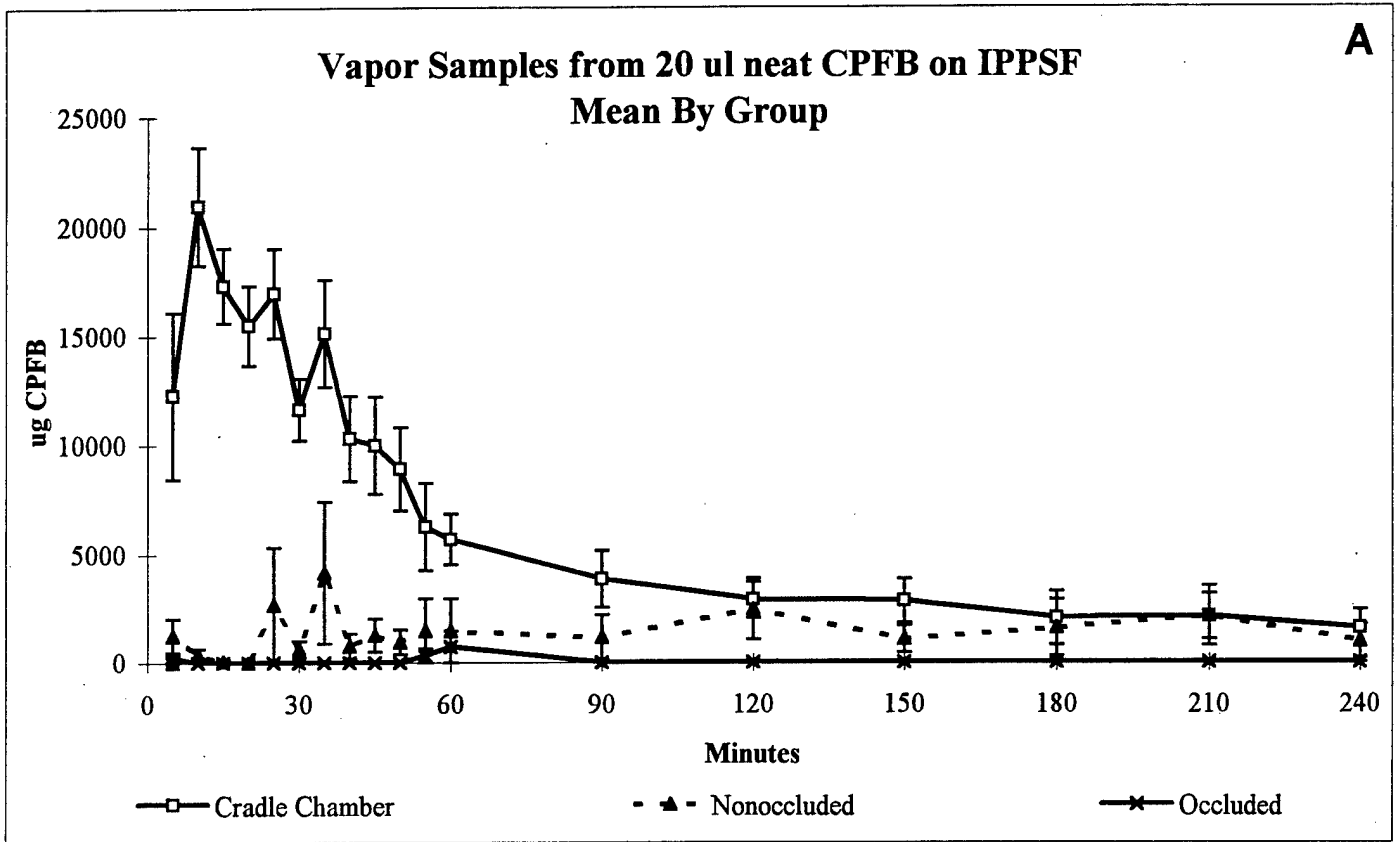

Figure 7

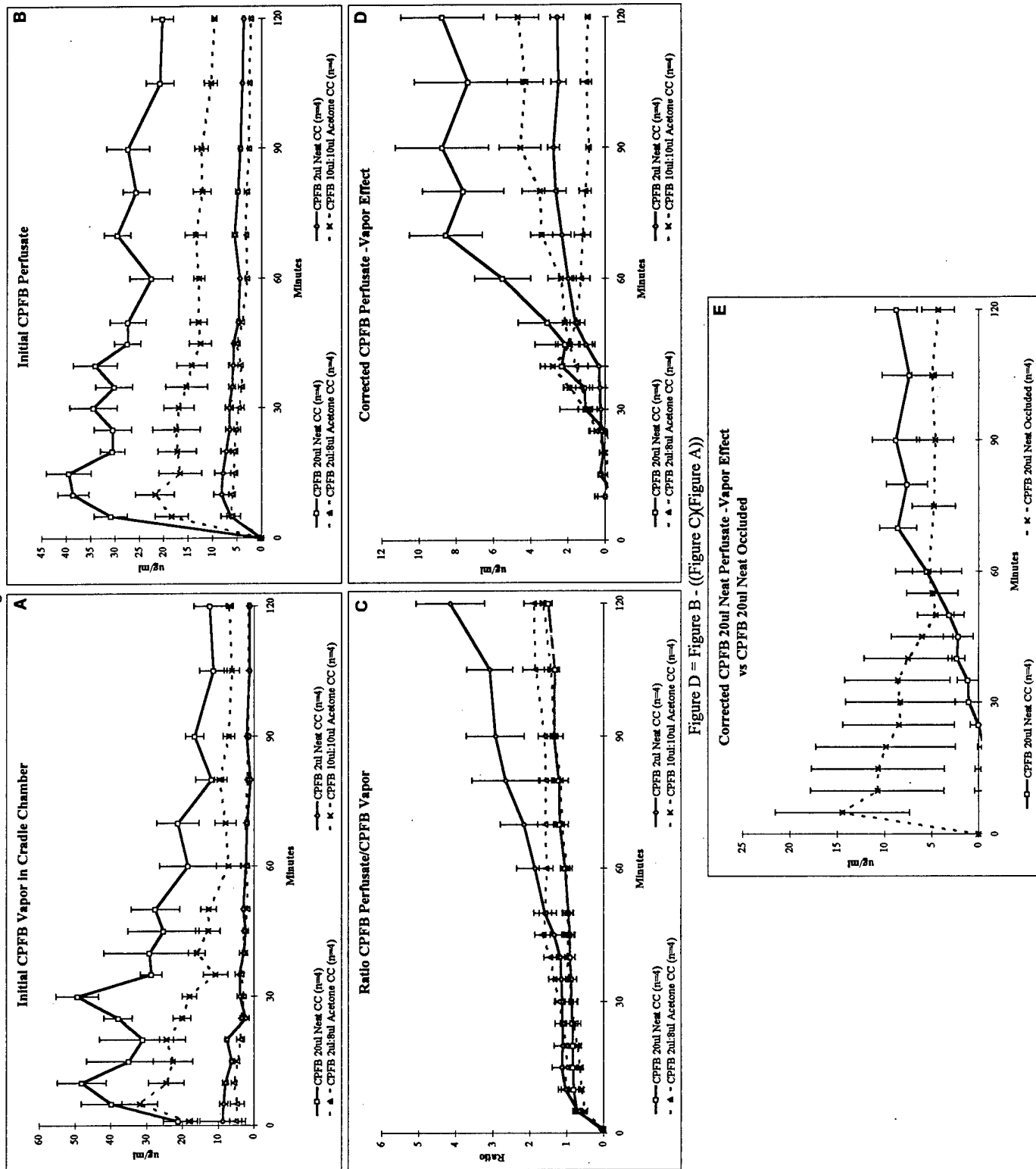

Figure D = Figure B - (Figure C)(Figure A)

Figure 8

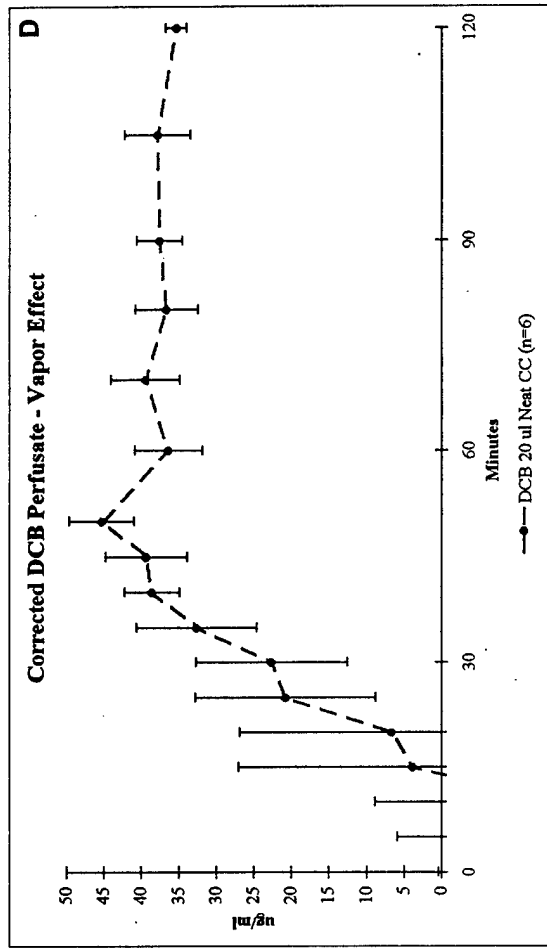
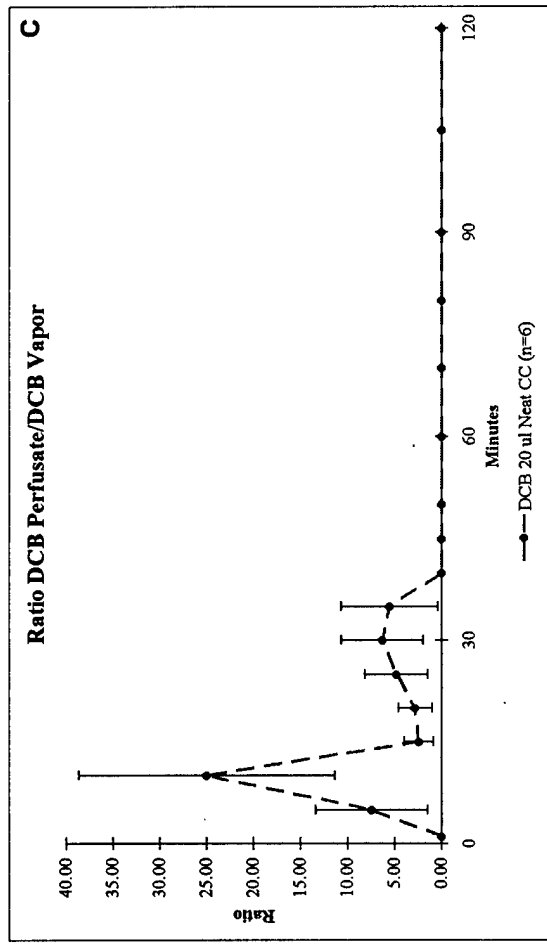
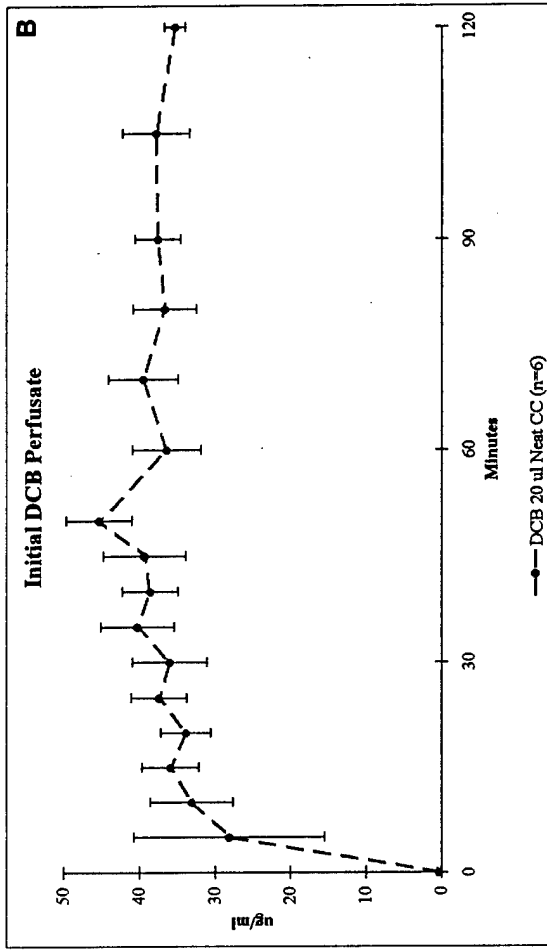
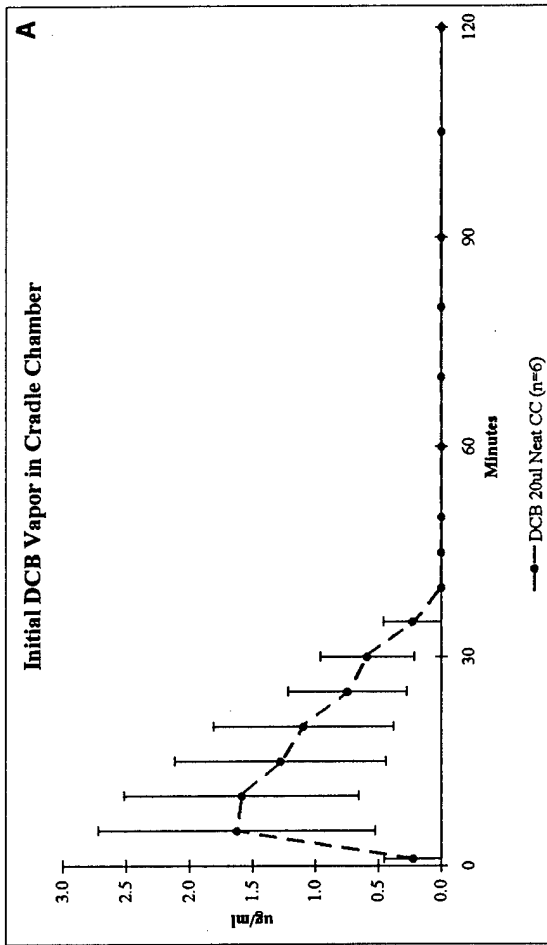

Figure D = Figure B - ((Figure C)(Figure A))

Figure 9

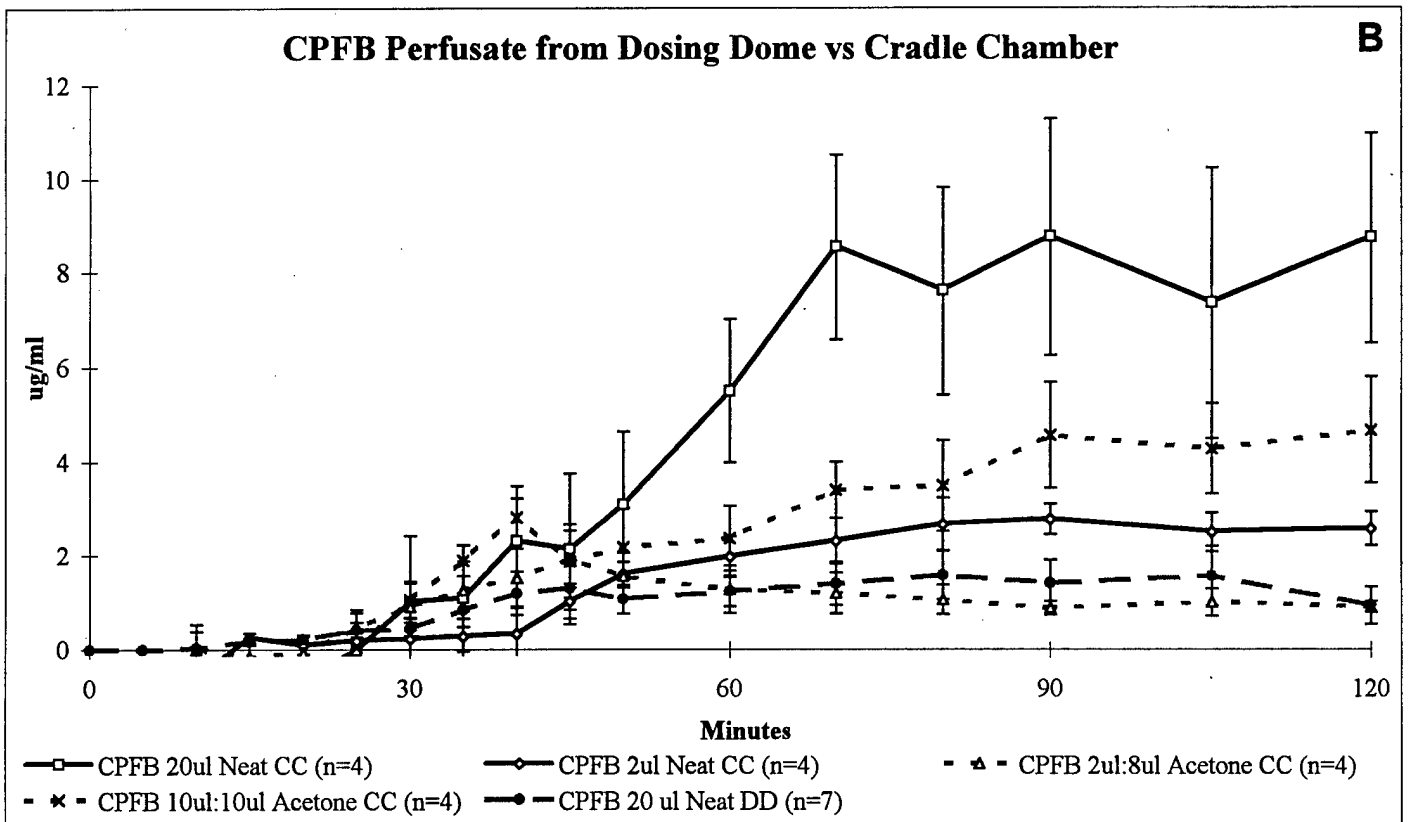
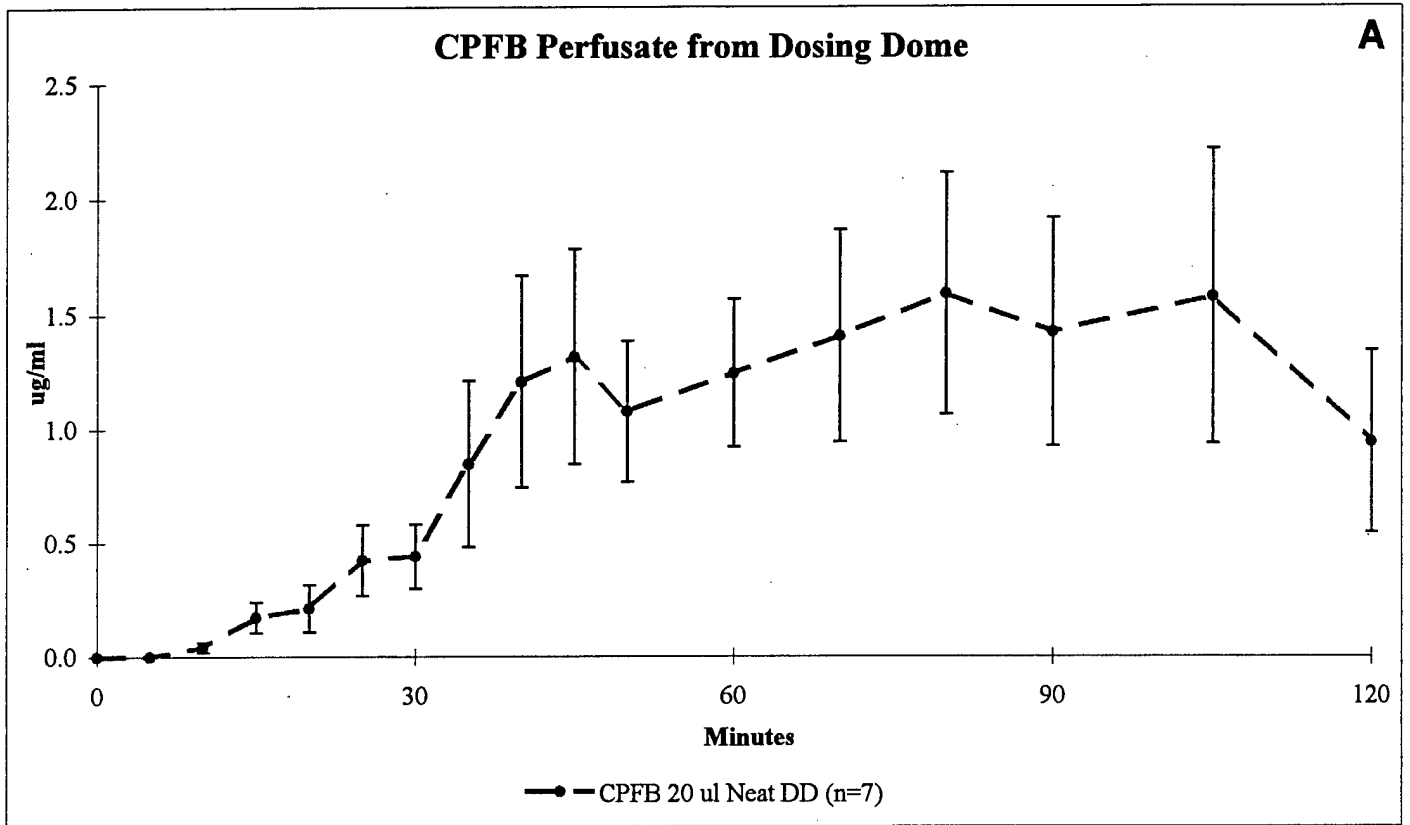

Figure 10

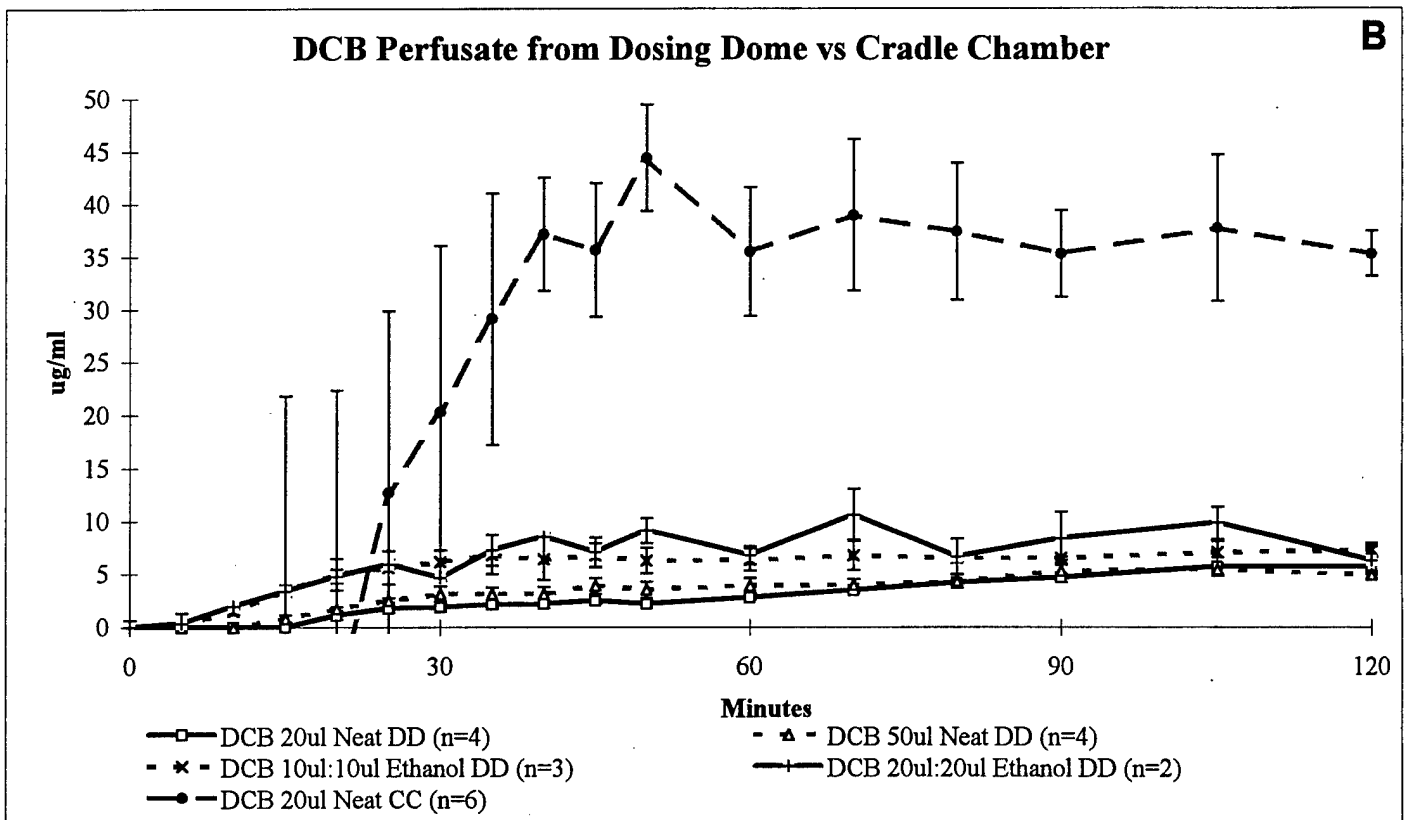
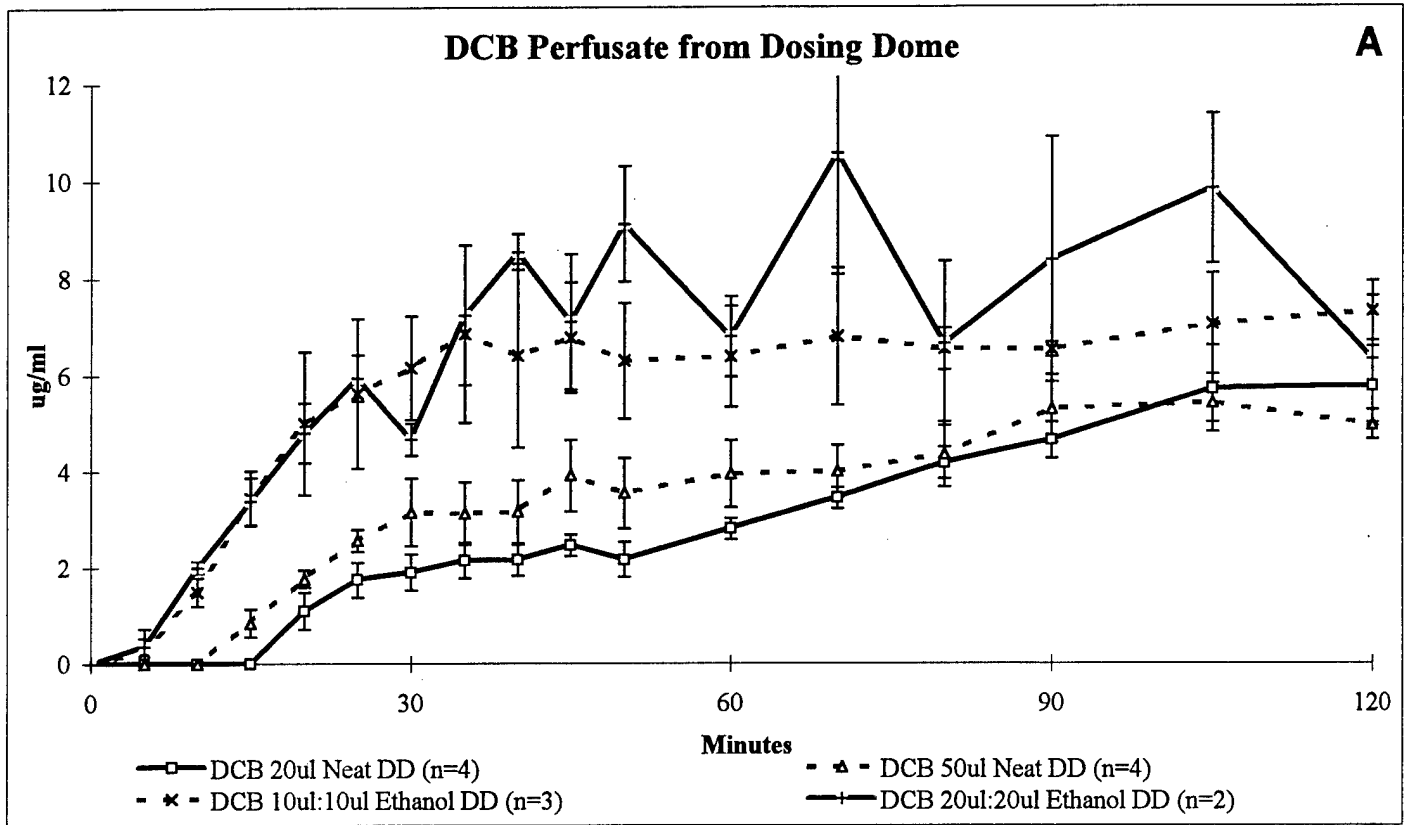

Figure 11
 CPFEB Residues from Cradle Chamber and Dosing Dome

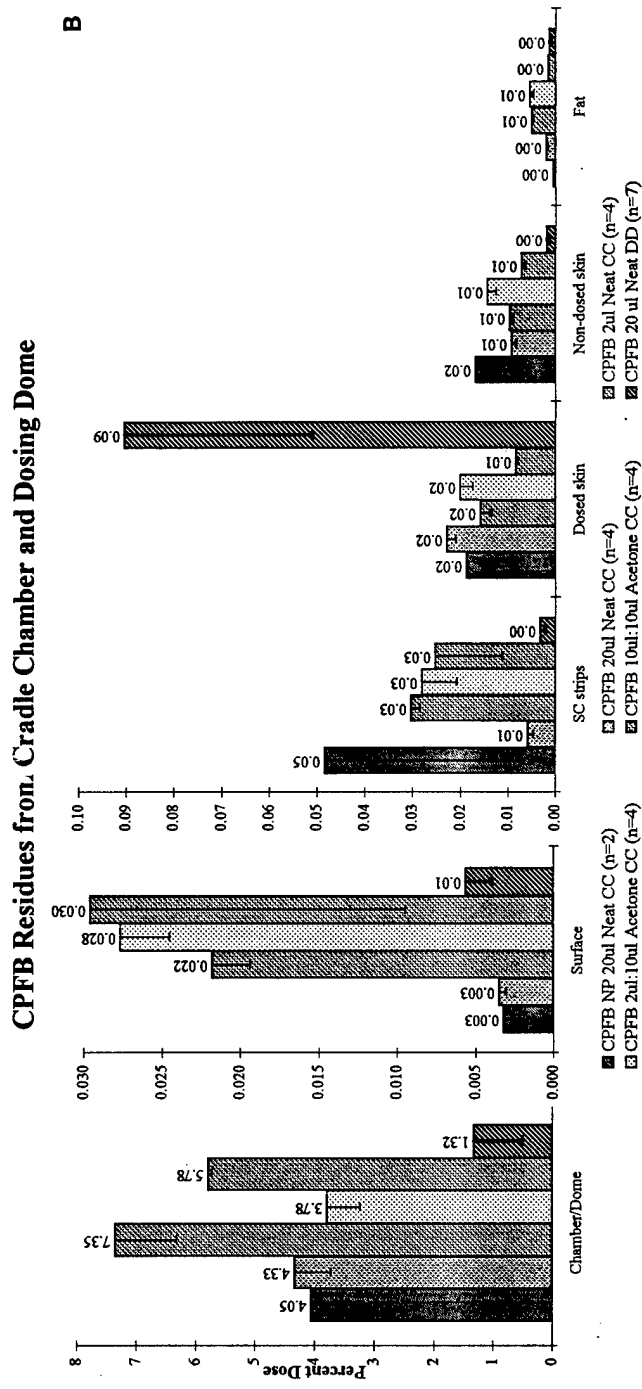
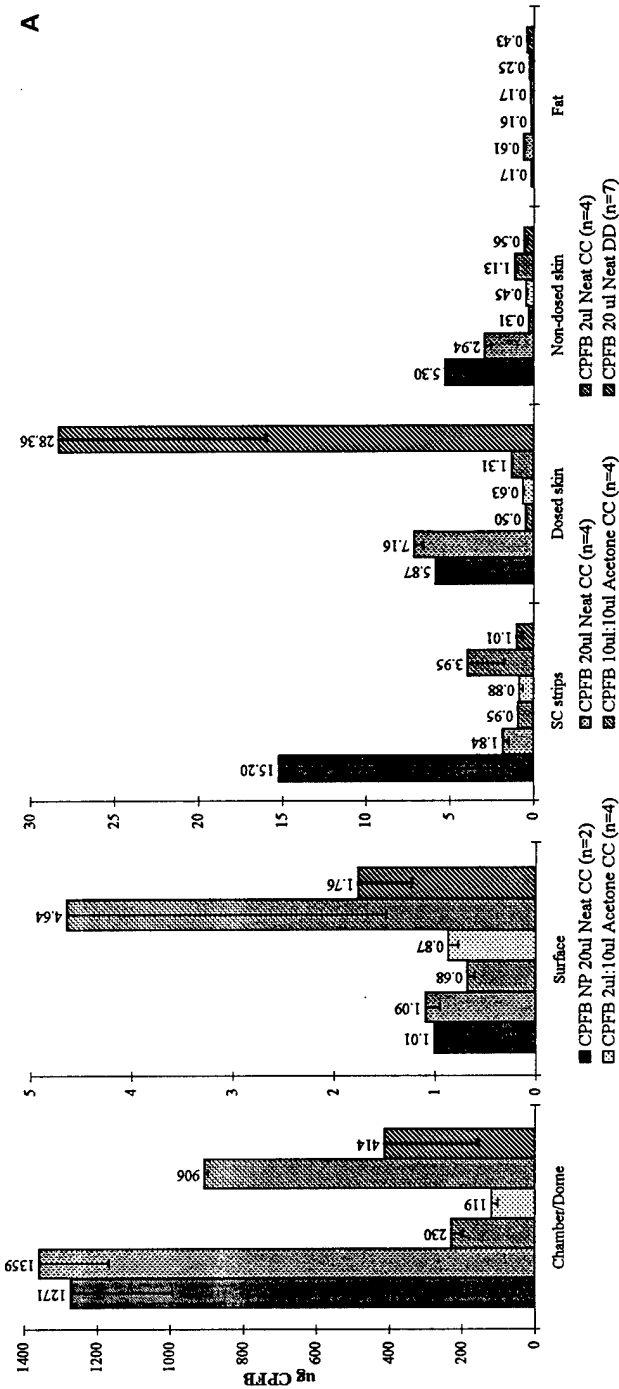
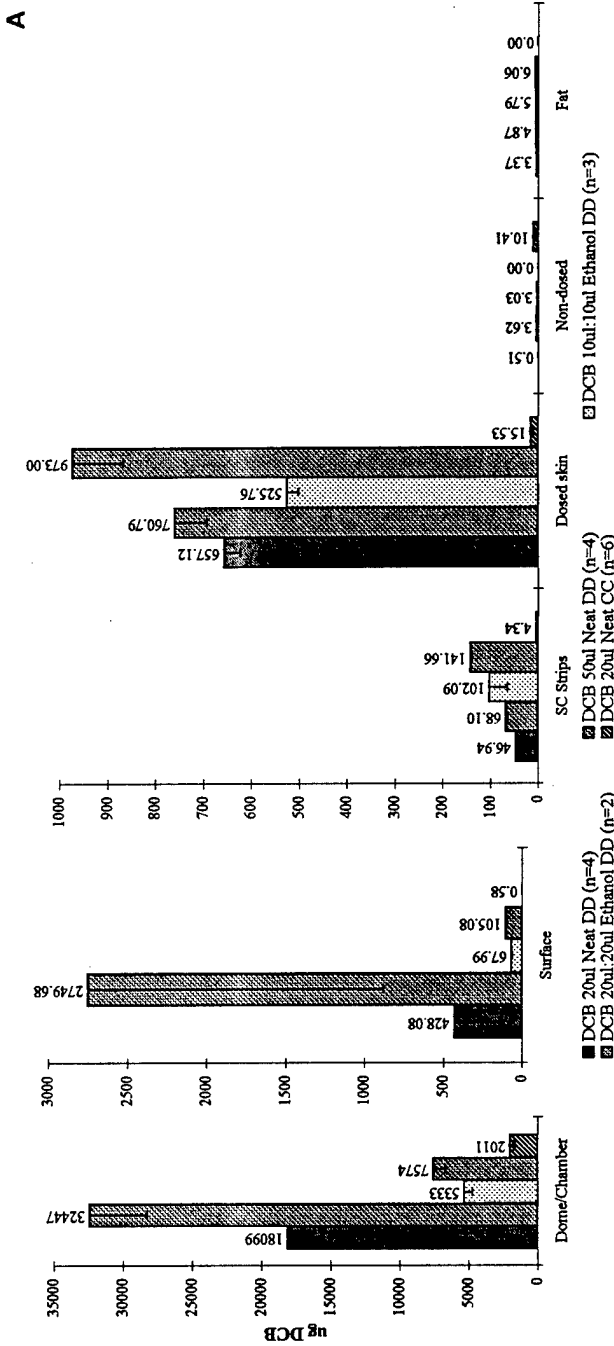
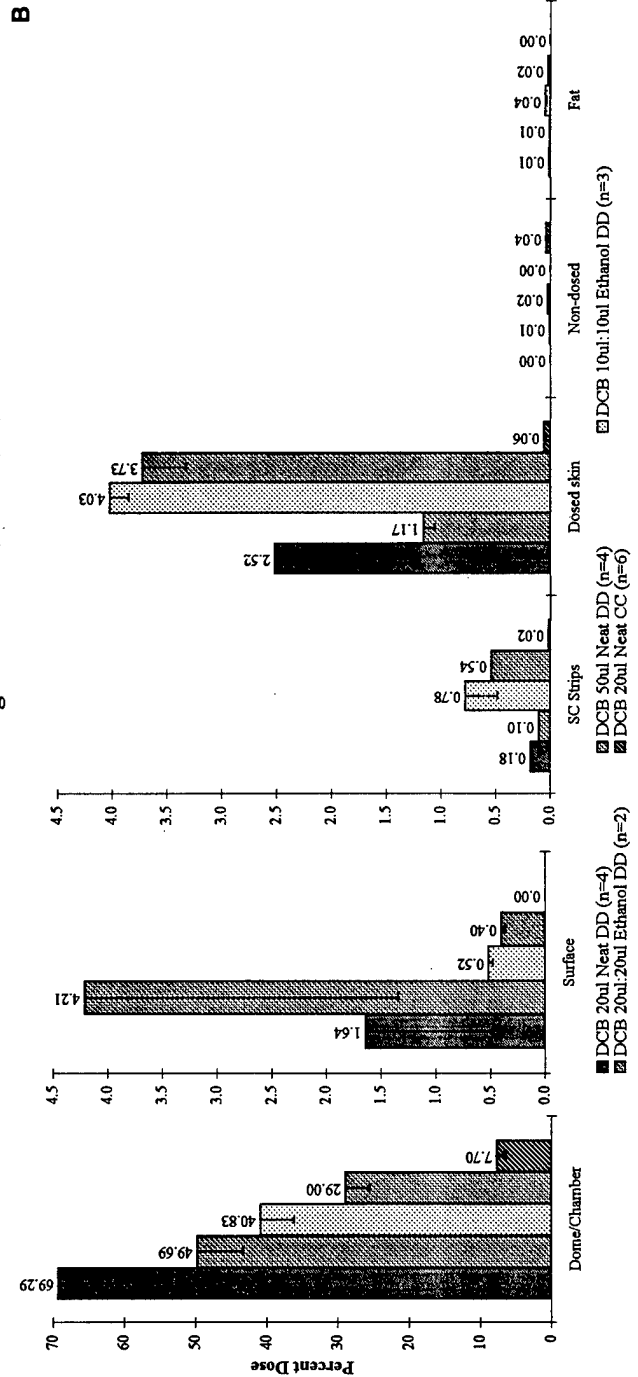

Figure 12

DCB Residues from Dosing Dome and Cradle Chamber



DCB Residues from Dosing Dome and Cradle Chamber



Doses from the cradle chamber (CC) and the dosing dome (DD) are compared. As expected, the nondosed skin from the cradle chamber is generally higher than the nondosed skin from the dosing dome reflecting the confounding exposure to test compound vapor. The nondosed skin was a 1 cm x 1 cm section of the area outside the dosing area. The fat was a 1 cm x 1 cm x 0.3 cm area of the fat under the dose area. The values for nondosed skin and fat have not been corrected for the remaining nondosed skin or the remaining fat in the skin flap. The maximum nondosed skin value without this correction is 0.06% of the dose. If this correction is made, that value increases to 0.48% of the dose. The nondosed skin value is insignificant for penetration or mass balance purposes since this value is always significantly less than the dosed skin value. For the fat, the largest difference this correction makes is from 0.06% to 1.15% of the dose. Because of the uncertainty of homogeneity, the fat value correction was not made. Two nonperfused (NP) skin flaps are included in Figure 11 to demonstrate the vapor effect. These two skin flaps were handled the same as all the others, including dosing and sample collection, however, the plastic tubing of the cannula was clipped so the perfusate dripped directly into the base of the cradle without traveling through the vasculature of the skin flap. An interesting observation is the elevated stratum corneum residues of CPFB seen when nonperfused skin is dosed compared to IPPSF values illustrating the importance of absorption to wash out penetrated drug after exposure.

Figures 13 and 14 illustrate absorption, penetration and recoveries for CPFB and DCB respectively. Absorption is the compound detected in the perfusate. Penetration is the absorption plus the compound detected in the tissues and the depth of penetration samples. Recovery is the total compound detected in all the samples. In the case of the cradle chamber, only the final vapor sample was used in this summation. Figure 13-A illustrates the percentage of the applied CPFB dose before the perfusate was corrected for the vapor effect. Figure 13-B illustrates the percentage of the applied CPFB dose after the vapor effect has been removed. Figures 13-C and 13-D illustrate CPFB mass before and after removal of the vapor effect, respectively. Figures 14-A, -B, -C and -D are the same values for DCB. Comparison of Figure 14-A to Figure 14-B demonstrates a very small vapor effect in DCB. This difference is much more pronounced with CPFB. This vapor effect changes the total absorption and thus the penetration, but as expected has no effect on the total recovery. Normalization to percentage of dose allows for direct comparison of different doses. Where appropriate, an analysis of variance (ANOVA, $\alpha = 0.05$, SAS) has been performed and listed on the Figures 13 and 14 -A and -B. As expected, DCB percent dose recoveries are higher than CPFB, due to lower volatility.

The development of the pharmacokinetic modeling strategies that might be applicable to such situations was originally developed in the first year of this project and are fully reported in Williams et al., 1995) and depicted in Figure 15. The actual permeability coefficient in this model [$K_{92}(t)$] is linked to the vehicle penetration in the stratum corneum. A model similar in structure could be applied to the data collected in these studies to estimate the rate constants observed under different dosing conditions. After attending the AFOSR Workshop at WPAFB in August 1996, it was agreed that the focus of future research efforts should be focused on using this approach to assess the absorption of complex mixtures which will be conducted in the USAFOSR supported grant awarded this year.

Figure 13

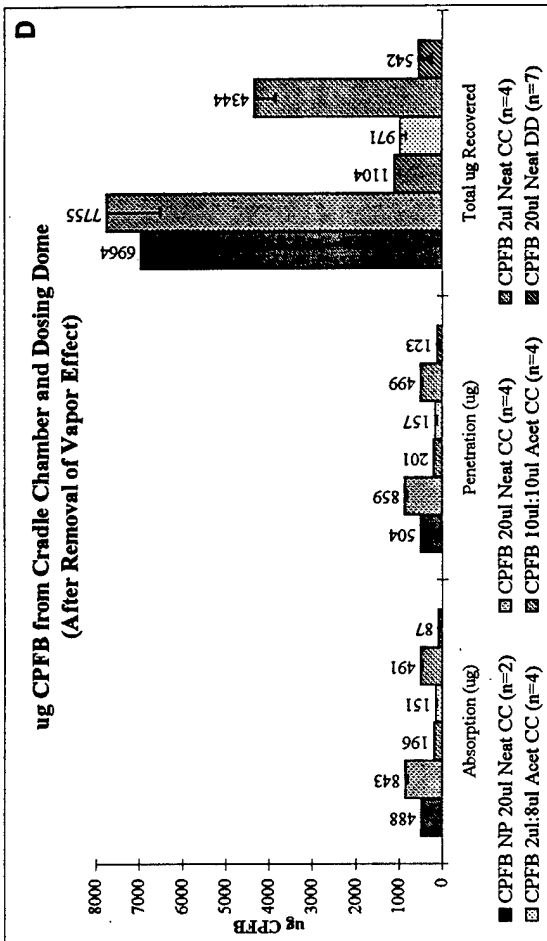
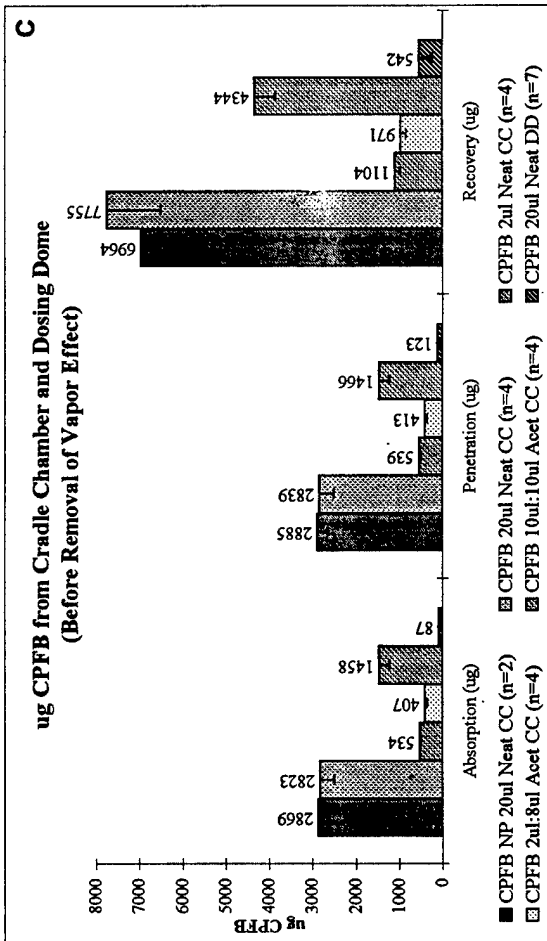
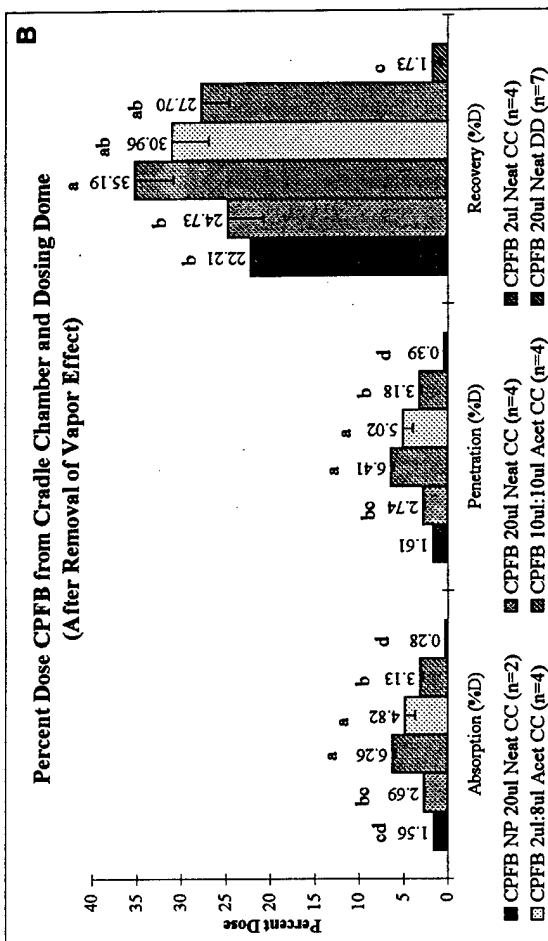
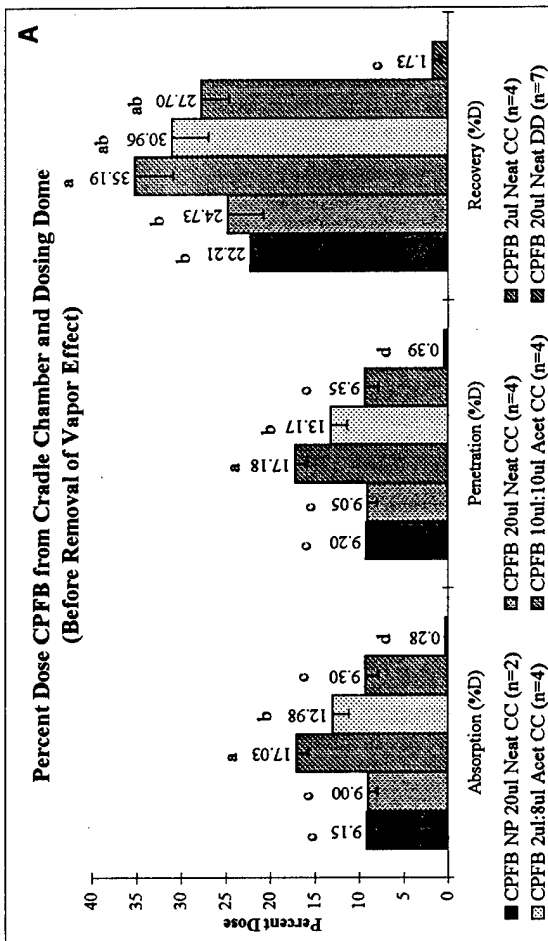

Figure 14

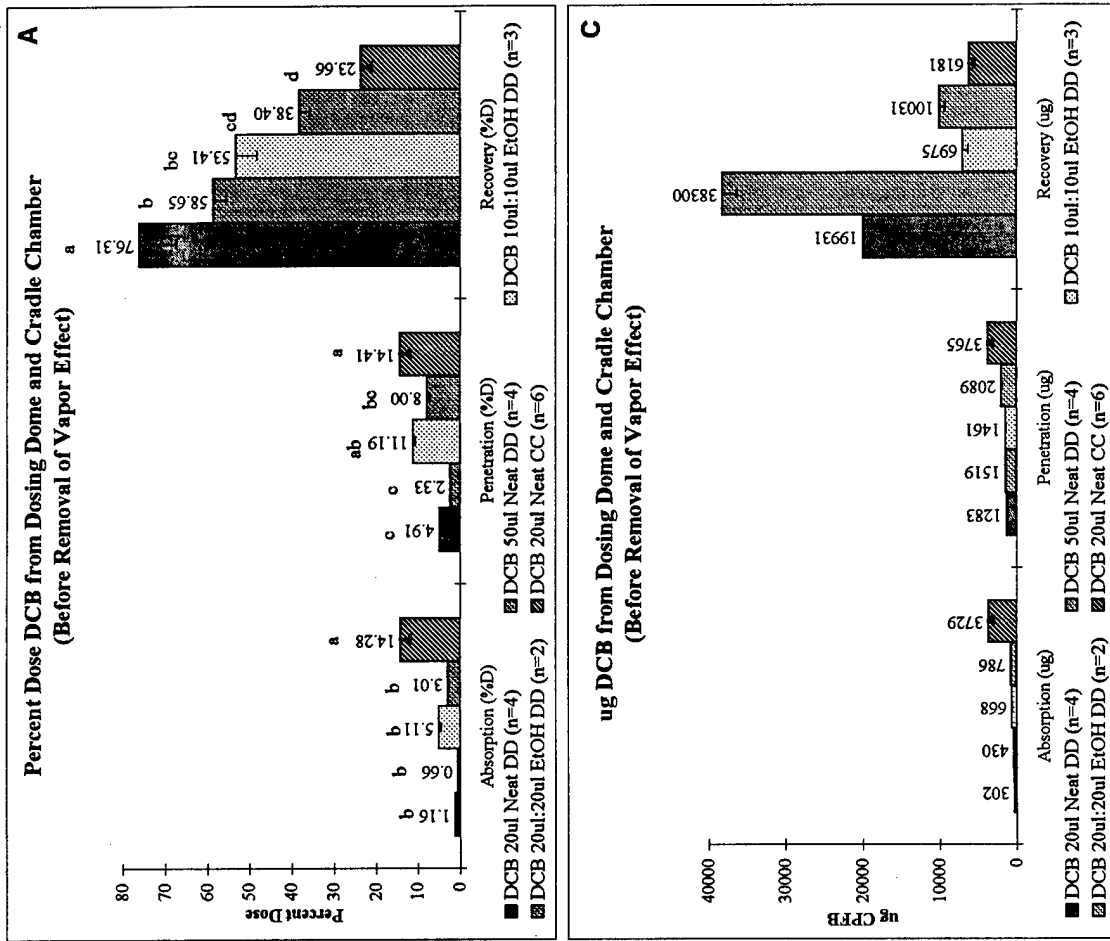

Figure 15

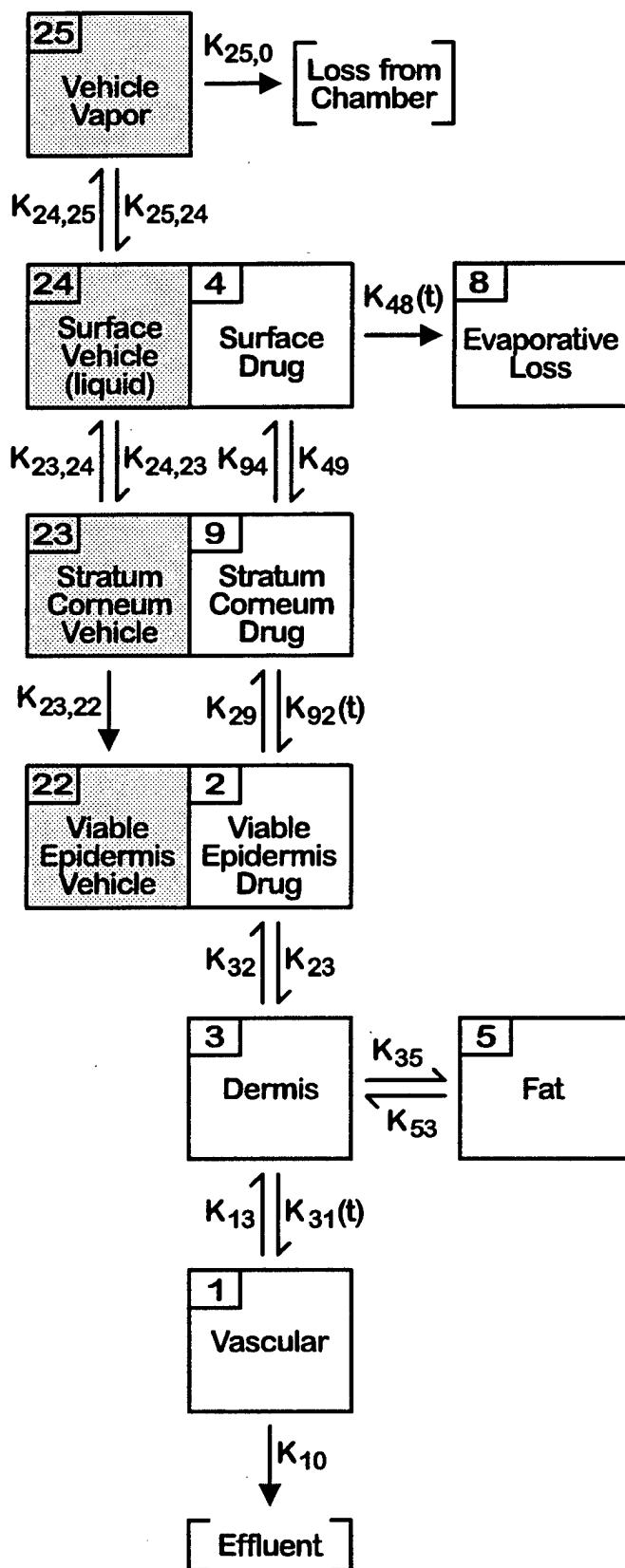
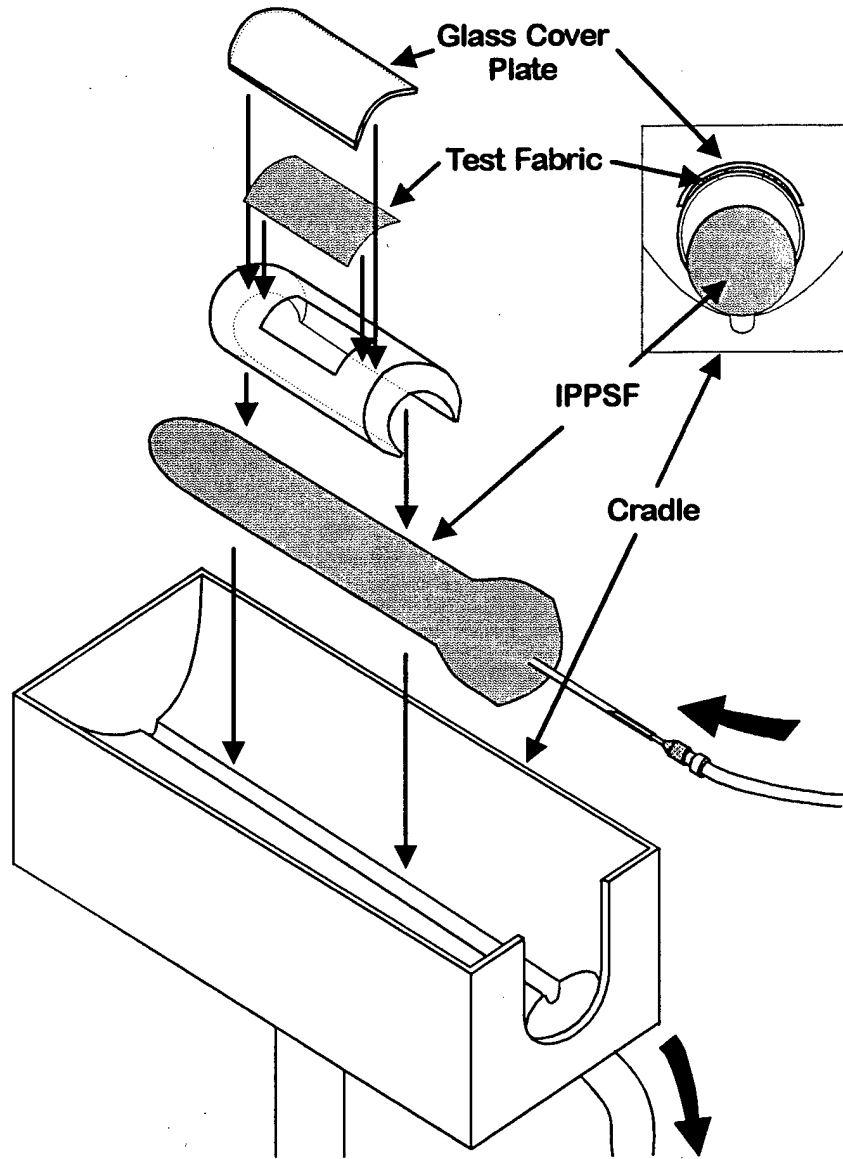

Figure 16



DISCUSSION

This project demonstrated significant differences in the absorption of CPF and DCB dependent upon the method used to dose the IPPSF. It also clearly illustrates the limitations of using a perfused biological preparation to assess vapor absorption in a manner relevant to field exposure scenarios. One important finding is that a significant fraction of volatile compound is lost before absorption occurs. At the end of the experimental periods, minimal absorbed doses of both CPF and DCB remained in the dose tissue. This was especially true in perfused skin preparations for CPF suggesting no long term depot effects of nonabsorbed compound occurs after an accidental spill. The 10-fold higher absorption in the CPF and the 12-fold higher absorption in the DCB from the cradle chamber over the dosing dome in each case is most likely due to the application of a liquid to the skin rather than a vapor, which physiochemically would be predicted to have different driving forces based on thermodynamic activity.

CPF is not absorbed through the skin if applied in a nonoccluded situation because evaporation is rapid and nearly complete. If the CPF is trapped in an occluded situation (all exposure protocols above), such as might occur between the skin and a flight suit, absorption is rapid. The next step in this set of experiments could develop a method for testing jet fuel spills on flight suits. Figure 16 illustrates a proposed dosing dome in which small swatches of flight suit fabrics may be held in place by a glass dome and dosed with the test compound to see if the test compound penetrates the flight suit material, and if so, is it at a high enough concentration to penetrate the skin.

All experiments compared within both the cradle chamber and dosing dome studies for both CPF and DCB demonstrated a dose dependent increase in absorption and penetration. However when corrected for applied dose by expressing as percent dose, the efficiency of the process was decreased with higher doses suggesting nonlinearity in the permeability coefficient.

There are some interesting observations concerning the solvent effects. With CPF, acetone decreased absorption and penetration although caused a greater retention of CPF in the surface concentrations, suggesting an interaction before stratum corneum penetration which results in marginally decreased penetration and absorption. A similar effect of acetone on surface deposition was previously observed with phenol and paranitrophenol in IPPSFs (Brooks and Riviere, 1996). In contrast, the effect of ethanol on DCB absorption is significantly enhanced absorption and penetration over neat DCB both in absolute mass and efficiency (% dose). In contrast to acetone's effect on CPF, ethanol decrease surface residues of DCB. This is consistent with an ethanol enhancing effect on DCB's permeability coefficient through skin. It is biologically significant that this effect was promulgated by vapor exposure of skin to ethanol through the use of the dosing dome. These studies clearly demonstrate that co-exposure of a penetrant to a vehicle changes the absorption characteristics of that penetrant and thus risk-assessments based solely on neat chemical studies may not be predictive of absorption when exposed as a component of a mixture. These results are consistent with our hypothesis that the absorption of a penetrant must be assessed in the context of the mixtures in which it is exposed (Baynes et al., 1996, 1997; Brooks and Riviere, 1996; Qiao et al., 1996; Williams et al., 1996). This is the focus of our future USAFOSR research.

ACKNOWLEDGMENTS

We would like to acknowledge the outstanding analytical contributions of Barbara Johnston for the GC analyses and the technical staff of the Cutaneous Pharmacology and Toxicology Center for the IPPSF perfusions. Finally we acknowledge the contributions of Dr. Patrick Williams to the development of the pharmacokinetic modeling approaches begun in this proposal.

PUBLICATIONS

Williams PL, Thompson D, Qiao GL, Monteiro-Riviere NA, Baynes RL, Riviere JE: The use of mechanistically defined chemical mixtures (MDCM) to assess component effects on the percutaneous absorption and cutaneous disposition of topically-exposed chemicals. II. Development of a general dermatopharmacokinetic model for use in risk assessment. Toxicol. Appl. Pharmacol. 141: 487-496, 1996.

Brooks JD, Riviere JE: Methods for assessing the percutaneous absorption of volatile chemicals in isolated perfused skin: Studies with chloropentafluorobenzene (CPF) and dichlorobenzene (DCB). *In Preparation.*

Riviere JE, Qiao GL, Brooks JD: The percutaneous absorption and penetration of dichlorobenzene (DCB) in isolated perfused skin. *In Preparation.*

Riviere JE and Brooks JD: The calculation of permeability constants in isolated perfused skin. *In preparation.*

The preliminary results of this research were presented at two "Skin Workshops" sponsored by the USAFOSR at Wright Patterson Air Force Base in July, 1994 and August, 1996. Presentations were also made at the Gordon Conference on Barrier Function of Mammalian Skin in Andover, NH in August 1995 and at the Table Ronde Roussel UCLAF n° 85 on "Passage of Drugs across Physiological Barriers," Institute Scientifique Roussel, Paris, France in December, 1996.

TRANSITIONS / TECHNOLOGY TRANSFERS

The dosing dome technique developed in this proposal will be applied in studying the dermal toxicity of cutaneous vesicants in research proposals planned to be submitted to the US Army next fiscal year. This technique will also be utilized in proposals to NIOSH on assessing protective strategies to prevent toxic vapor exposure to skin using a technique similar to that illustrated in Figure 16 for assessing exposure after spillage on a protective suit fabric. The initial pharmacokinetic model formed the basis for our group's pharmacokinetic approach to assess absorption of complex chemical mixtures which will be supported by competitive grants funded this year by USAFOSR (FQ 8671-98-00462) and PHS/CDC/ATSDR (U61/ATU484504).

REFERENCES

- Baynes RE, Brownie C, Freeman H, Riviere JE: In vitro percutaneous absorption of benzidine in complex mechanistically defined chemical mixtures. Toxicol. Appl. Pharmacol. 141: 497-506, 1996.
- Baynes RE, Halling KB, Riviere JE: The influence of diethyl-m-toluamide (DEET) on percutaneous absorption of permethrin and carbaryl. Toxicol. Appl. Pharmacol. 144: 332-339, 1997.
- Bowman KF, Monteiro-Riviere NA, Riviere JE: Development of surgical techniques for preparation of in vitro isolated perfused porcine skin flaps for percutaneous absorption studies. Am. J. Vet. Res. 52:75-82, 1991.
- Brooks JD, Riviere JE: Quantitative percutaneous absorption and cutaneous distribution of binary mixtures of phenol and p-nitrophenol in isolated perfused porcine skin. Fundam. Appl. Toxicol. 32: 233-243, 1996.
- Carver MP, Williams PL, Riviere JE: The isolated perfused porcine skin flap (IPPSF). III. Percutaneous absorption pharmacokinetics of organophosphates, steroids, benzoic acid and caffeine. Toxicol. Appl. Pharmacol. 97:324-337, 1989.
- Chang SK, Williams PL, Dauterman WC, Riviere JE: Percutaneous absorption, dermatopharmacokinetics, and related biotransformation studies of carbaryl, lindane, malathion and parathion in isolated perfused porcine skin. Toxicology 91: 269-280, 1994.
- Heit M, Williams P, Jayes FL, Chang SK, Riviere JE: Transdermal iontophoretic peptide delivery. In vitro and In vivo studies with luteinizing hormone releasing hormone (LHRH). J. Pharm. Sci. 82:240-243, 1993.
- McDougal JN, Jepson GW, Clewell HJ, Andersen ME: Dermal absorption of dihalomethane vapors. Toxicol. Appl. Pharmacol. 79: 150-158, 1985.
- McDougal JN, Jepson GW, Clewell HJ, MacNaughton MG, Andersen ME: A physiological pharmacokinetic model for dermal absorption of vapors in the rat. Toxicol. Appl. Pharmacol. 85: 286-294, 1986.
- Monteiro-Riviere NA, Bowman KF, Scheidt VJ, Riviere JE: The isolated perfused porcine skin flap (IPPSF): II. Ultrastructural and histological characterization of epidermal viability. In Vitro Toxicol. 1:241-252, 1987.
- Monteiro-Riviere NA, Inman AO, Riviere JE, McNeill SC, Francoeur ML: Topical penetration of piroxicam is dependent on the distribution of the local cutaneous vasculature. Pharm. Res. 10: 1326-1331, 1993.
- Qiao GL, Brooks JD, Baynes RL, Monteiro-Riviere NA, Williams PL, Riviere JE: The use of mechanistically defined chemical mixtures (MDCM) to assess component effects on the percutaneous absorption and cutaneous disposition of topically-exposed chemicals. I. Studies with parathion mixtures in isolated perfused porcine skin. Toxicol. Appl. Pharmacol. 141: 473-486, 1996.
- Riviere JE, Bowman KF, Monteiro-Riviere NA, Dix LP, Carver MP: The isolated perfused porcine skin flap (IPPSF). I. A novel in vitro model for percutaneous absorption and cutaneous toxicology studies. Fundam. Appl. Toxicol. 7:444-453, 1986.

- Riviere JE, Brooks JD, Williams PL, Monteiro-Riviere NA: Toxicokinetics of topical sulfur-mustard penetration, disposition and vascular toxicity in isolated perfused porcine skin. Toxicol. Appl. Pharmacol. 135: 25-34, 1995a.
- Riviere JE, Monteiro-Riviere NA, Williams PL: Isolated perfused porcine skin flap as an in vitro model for predicting transdermal pharmacokinetics. Eur. J. Pharm. Biopharm. 41: 152-162, 1995b.
- Riviere JE, Monteiro-Riviere NA: The isolated perfused porcine skin flap as an in vitro model for percutaneous absorption and cutaneous toxicology. Critical Reviews in Toxicol. 21:329-344, 1991.
- Riviere JE, Williams PL, Hillman R, Mishky L: Quantitative prediction of transdermal iontophoretic delivery of arbutamine in humans using the in vitro isolated perfused porcine skin flap (IPPSF). J. Pharm. Sci. 81:504-507, 1992.
- Williams PL, Carver MP, Riviere JE: A physiologically relevant pharmacokinetic model of xenobiotic percutaneous absorption utilizing the isolated perfused porcine skin flap (IPPSF). J. Pharm. Sci. 79:305-311, 1990.
- Williams PL, Riviere JE: A biophysically-based dermatopharmacokinetic compartment model for quantifying percutaneous penetration and absorption of topically applied agents. I. Theory. J. Pharm. Sci. 84: 599-608, 1995.
- Williams PL, Thompson D, Qiao GL, Monteiro-Riviere NA, Baynes RL, Riviere JE: The use of mechanistically defined chemical mixtures (MDCM) to assess component effects on the percutaneous absorption and cutaneous disposition of topically-exposed chemicals. II. Development of a general dermatopharmacokinetic model for use in risk assessment. Toxicol. Appl. Pharmacol. 141: 487-496, 1996.