

JPRS-UEQ-90-003
16 FEBRUARY 1990



**FOREIGN
BROADCAST
INFORMATION
SERVICE**

JPRS Report

DECLASSIFICATION STATEMENT 1
Approved for public release
Distribution Unlimited

Science & Technology

***USSR: Engineering &
Equipment***

19980121 169

REPRODUCED BY
U.S. DEPARTMENT OF COMMERCE
NATIONAL TECHNICAL INFORMATION SERVICE
SPRINGFIELD, VA. 22161

[DTIC QUALITY INSPECTED 3]

SCIENCE & TECHNOLOGY
USSR: ENGINEERING & EQUIPMENT

CONTENTS

AVIATION AND SPACE TECHNOLOGY

Stability of Permanent Rotations of Gyrostat in Magnetic Field [B. Zh. Kirgizbayeva; IZVESTIYA AKADEMII NAUK KAZAKHSKOY SSR: SERIYA FIZIKO-MATEMATICHESKAYA, No 1, Jan-Feb 89].....	1
Vibrations of Flexible Current-Carrying Cylindrical Shells in Magnetic Field [Ya. A. Grigoryenko, L. V. Molchenko; DOKLADY AKADEMII NAUK UKRAINSKOY SSR: SERIYA A--FIZIKO- MATEMATICHESKIYE I TEKHNICHESKIYE NAUKI, No 8, Aug 89].....	5
Interaction of Two Parallel Circular Cylinders in Perfect Liquid During Passage of Acoustic Wave [A. P. Zhuk; DOKLADY AKADEMII NAUK UKRAINSKOY SSR: SERIYA A--FIZIKO-MATEMATICHESKIYE I TEKHNICHESKIYE NAUKI, No 8, Aug 89].....	10
R-Functions and Projection Methods in Problems of Torsion of Prismatic Rods With Regard to Parameters of Thin Strengthening Coating [A. P. Slesarenko, Ya. P. Buzko; DOKLADY AKADEMII NAUK UKRAINSKOY SSR: SERIYA-A--FIZIKO-MATEMATICHESKIYE I TEKHNICHESKIYE NAUKI, No 8, Aug 89].....	17

INDUSTRIAL TECHNOLOGY, PLANNING, PRODUCTIVITY

LA52 Automatic Assembly Line [G. A. Amnuel; AVTOMOBILNAYA PROMYSHLENNOST, No 1, Jan 89].....	23
A Robot for Equipment Loading [K. B. Alekseyev, V. I. Matveyenko, et al.; AVTOMOBILNAYA PROMYSHLENNOST, No 1, Jan 89].....	28
ESKD [Unified Design Documentation System] Classifier: The Basis for Creation of SAPR [Computer-Assisted Design System] for Comprehensive Execution of Recurring Tasks in the Development of New Technology, Processes and Industrial Process Control [A. I. Aleksandrov, STANDARTY I KACHESTVO, No 2, Feb 89].....	31
Methodology of Maintaining a Technological Classifier of Engineering and Instrument-Making Components in Coordination With ESKD [Unified System of Design Documentation] Classifier [B. S. Mendrikov, S. L. Taller, et al.; STANDARTY I KACHESTVO, No 2, Feb 89].....	37

MISCELLANEOUS

Production of High-Temperature Superconducting Materials [V. P. Seminozhenko, M. B. Kosmyna, et al.; VISNYK AKADEMIYI NAUK UKRAYINSKOYI RSR, No 12, Dec 88].....	46
Gas Diesel KamAZ Trucks [AVTOMOBILNAYA PROMYSHLENNOST, No 1, Jan 89].....	53

UDC 531.38

Stability of Permanent Rotations of Gyrostat in Magnetic Field

907F0007A Alma-Ata IZVESTIYA AKADEMII NAUK KAZAKHSKOY SSR: SERIYA FIZIKO-MATEMATICHESKAYA in Russian No 1, Jan-Feb 89 (manuscript received 6 Nov 87) pp 73-76

[Article by B. Zh. Kirgizbayeva, Kazakh Pedagogical Institute imeni Abay, Alma-Ata; first paragraph is IZVESTIYA AKADEMII NAUK KAZAKHSKOY SSR: SERIYA FIZIKO-MATEMATICHESKAYA abstract]

[Text] The permanent rotations of an absolutely solid body with a rotor moving around a fixed point in an axiosymmetrical superposition of force fields, i.e., newtonian, electrical, and magnetic, are examined. It is assumed that the gyrostat is electrically charged. A lagrangian expression and a Routh function in Euler angles and one class of permanent gyrostat rotations are found. The geometric location of the permanent rotation axes and sufficient stability conditions are found by using Routh's theorem in an investigation of the stability of the permanent rotations.

We will examine the motion of an electrically charged gyrostat around a fixed point O in an axiosymmetrical superposition of newtonian, electrical, and magnetic fields arising from a fixed, rather removed center O' . The charge is assumed to be bound to the body, and the charge density is an arbitrary function of the body's points. The system has a magnetic moment directed along the line OO' . The intensity vector of the homogeneous magnetic field H and the vector $\overline{OO'}$ are directed along fields' symmetry axis.

We will specify the gyrostat's position in terms of the Euler angles φ , ψ , and θ , which constitute the axes of a nonfixed coordinate system $Ox_1y_1z_1$ with the axes of the fixed coordinate system $Ox_0y_0z_0$. The Oz_0 axis is directed parallel to the force fields' symmetry axis. We will designate its unit vector by the vector $\bar{\gamma}(\sin \theta \sin \varphi, \sin \theta \cos \varphi, \cos \theta)$. We will assume that in the general case the axes of the nonfixed system do not coincide with the principal axes of the carrier body's inertia. The forces acting on the system allow a generalized potential, and the lagrangian has the form

$$L = \bar{\omega} I \bar{\omega} + \bar{\omega} \cdot \bar{k} - \frac{1}{2} \bar{\omega} \bar{H} I \bar{\gamma} - \bar{\gamma} \cdot \bar{s}' - \frac{1}{2} \lambda \bar{\gamma}^T I \bar{\gamma} - \frac{1}{2} \mu \bar{\gamma}^T I \bar{\gamma},$$

where ω is the angular velocity and the matrix I , which characterizes the charge distributions, is similar to the inertia tensor of the body I :

$$I = \begin{pmatrix} A_1 & -D_1 & -E_1 \\ -D_1 & B_1 & -F_1 \\ -E_1 & -F_1 & C_1 \end{pmatrix}, \quad I = \begin{pmatrix} a_1^* & -b_3 & -b_2 \\ -b_3 & a_2^* & -b_1 \\ -b_2 & -b_1 & a_3^* \end{pmatrix};$$

where $\bar{s}'(s'_1, s'_2, s'_3)$ is the radius vector of the "generalized mass center" of the system¹ relative to $Ox_1y_1z_1$; $\bar{k}(k_1, k_2, k_3)$ is the kinetic moment of the rotating part of the gyrostat (rotor); and λ and μ are some constants.^{1,2}

The integral of the areas $\delta L / \delta \dot{\psi} = Q = \text{const}$ corresponds to the cyclic coordinate ψ . With its help we will ignore the variable $\dot{\psi}$ and introduce a Routh function by means of the relationship $R = L - Q\dot{\psi}$. In view of the cyclicity of the coordinate, the system can effect permanent motions

$$(1) \quad \theta = \frac{\pi}{2}, \quad \dot{\theta} = 0, \quad \varphi = \frac{\pi}{2}, \quad \dot{\varphi} = 0, \quad \dot{\psi} = \dot{\psi}_0 = \omega_0 = \text{const}$$

around the fields' symmetry axis.

By using the lagrangian, we obtain the necessary and sufficient conditions for the feasibility of a steady motion:

$$(2) \quad \begin{aligned} D_1\omega_0^2 - k_2\omega_0 + Hb_3\omega_0 + s'_2 - \lambda D_1 - \mu b_3 &= 0, \\ E_1\omega_0^2 - k_3\omega_0 + Hb_2\omega_0 + s'_3 - \lambda E_1 - \mu b_2 &= 0. \end{aligned}$$

By excluding ω_0 from system (2), we obtain the relationship

$$(3) \quad \begin{aligned} E_1 &= [k_2 - Hb_3 \pm \sqrt{(Hb_3 - k_2)^2 - 4D_1(s'_2 - \lambda D_1 - \mu b_3)}] = \\ &= D_1[k_3 - Hb_2 \pm \sqrt{(Hb_2 - k_3)^2 - 4E_1(s'_3 - \lambda E_1 - \mu b_2)}], \end{aligned}$$

which, generally speaking, specifies the arbitrary surface of the gyrostat's possible permanent rotation axes in the superposition of the fields under examination. Not all of the kinematically possible permanent rotation axes whose directing cosines satisfy equation (3) will be dynamically possible but rather only those that satisfy the inequalities

$$(4) \quad \begin{aligned} (Hb_3 - k_2)^2 - 4D_1(s'_2 - \lambda D_1 - \mu b_3) &\geq 0, \\ (Hb_2 - k_3)^2 - 4E_1(s'_3 - \lambda E_1 - \mu b_2) &\geq 0, \end{aligned}$$

emanating from equations (2).

Upon the transition from the coordinate system $Ox_1y_1z_1$ to the coordinate system $Oxyz$, the axes of which are directed along the body's principal inertia axes in accordance with the formulas

$$\begin{aligned}
A_1 &= (A \sin^2 \varphi + B \cos^2 \varphi) \sin^2 \theta + C \cos^2 \theta, \quad B_1 = A \cos^2 \varphi + B \sin^2 \varphi, \\
C_1 &= (A \sin^2 \varphi + B \cos^2 \varphi) \cos^2 \theta + C \sin^2 \theta, \quad D_1 = (A - B) \sin \varphi \cos \varphi \sin \theta, \\
E_1 &= (A \sin^2 \varphi + B \cos^2 \varphi - C) \sin \theta \cos \theta, \quad F_1 = -(A - B) \sin \varphi \cos \varphi \cos \theta, \\
(5) \quad s'_1 &= s_3 \cos \theta + s_1 \sin \varphi \sin \theta + s_2 \cos \varphi \sin \theta, \quad s'_2 = -(s_1 \cos \varphi - s_2 \sin \varphi), \\
s'_3 &= s_3 \sin \theta - s'_2 \cos \varphi \cos \theta - s_1 \sin \varphi \cos \theta,
\end{aligned}$$

we derive relationship (3) in the form

$$\begin{aligned}
(6) \quad & (A \sin^2 \varphi + B \cos^2 \varphi - C) \sin \theta \cos \theta \{k_2 - H b_3 \pm [(H b_3 - k_2)^2 - \\
& - 4(A - B) \sin \varphi \cos \varphi \sin \theta (s_2 \sin \varphi - s_1 \cos \varphi - \lambda(A - B) \sin \varphi \cos \varphi \sin \theta - \\
& - \mu b_2)]^{1/2}\} = (A - B) \sin \varphi \cos \varphi \sin \theta \{k_3 - H b_2 \pm [(H b_2 - k_3)^2 - \\
& - 4(A \sin^2 \varphi + B \cos^2 \varphi - C) (s_3 \sin \theta - s_2 \cos \varphi \cos \theta - s_1 \sin \varphi \cos \theta - \\
& - \lambda(A \sin^2 \varphi + B \cos^2 \varphi - C) \sin \theta \cos \theta - \mu b_2) \sin \theta \cos \theta]^{1/2}\},
\end{aligned}$$

$$\begin{aligned}
(7) \quad & (H b_3 - k_2)^2 - 4(A - B) (s_2 \sin \varphi - s_1 \cos \varphi - \lambda(A - B) \sin \varphi \cos \theta - \\
& - \mu b_2) \sin \varphi \cos \varphi \sin \theta \geq 0, \\
& (H b_2 - k_3)^2 - 4(A \sin^2 \varphi + B \cos^2 \varphi - C) [s_3 \sin \theta - s_2 \cos \varphi \cos \theta - \\
& - s_1 \sin \varphi \cos \theta - \lambda(A \sin^2 \varphi \cos \theta \sin \theta + B \cos^2 \varphi \sin \theta \cos \theta - C \sin \theta \cos \theta) - \\
& - \mu b_2] \sin \theta \cos \theta \geq 0.
\end{aligned}$$

We will note that, in the case where magnetic and electrical fields are absent and $\bar{k} = 0$, from (6) and (7) we obtain the well-known Staud cone for permanent rotation axes of a heavy solid body³: $(B - C) s_1 \sin \theta \times \cos \varphi \cos \theta + (C - A) s_2 \sin \theta \cos \theta \sin \varphi + (A - B) s_3 \sin^2 \theta \sin^2 \varphi \cos \varphi = 0$ and for the condition $(A - B) \sin \theta \sin \varphi \cos \varphi (s_2 \cos \varphi - s_1 \sin \varphi) \leq 0$, where s_1 , s_2 , and s_3 are the coordinates of the gravity center.

To investigate the stability of the steady motions (1) of the gyrostat, we will expand the Routh function into a Taylor series in terms of the perturbations of the angles $\theta = \pi/2 + u$ and $\varphi = \pi/2 + v$:

$$(8) \quad R = \frac{1}{2} [a_{11} \dot{u}^2 + 2a_{12} \dot{u} \dot{v} + a_{22} \dot{v}^2 + c_{11} u^2 + 2c_{12} uv + c_{22} v^2 + g_{11} v \dot{u} + g_{22} u \dot{v} \dots],$$

where

$$\begin{aligned}
a_{11} &= \left(\frac{\partial^2 R}{\partial \theta^2} \right)_0; \quad a_{12} = \left(\frac{\partial^2 R}{\partial \theta \partial \dot{\varphi}} \right)_0; \quad a_{22} = \left(\frac{\partial^2 R}{\partial \dot{\varphi}^2} \right)_0; \quad c_{11} = \left(\frac{\partial^2 R}{\partial \theta^2} \right)_0 < 0, \quad c_{12} = \\
&= \left(\frac{\partial^2 R}{\partial \theta \partial \dot{\varphi}} \right)_0 < 0; \quad c_{22} = \left(\frac{\partial^2 R}{\partial \dot{\varphi}^2} \right)_0 < 0; \quad g_{11} = \left(\frac{\partial^2 R}{\partial \theta \partial \dot{\varphi}} \right)_0; \quad g_{22} = \left(\frac{\partial^2 R}{\partial \dot{\varphi} \partial \theta} \right)_0, \quad \text{index } 0
\end{aligned}$$

means that the calculation is being performed for the values in (1).

According to Routh's theorem, a nonperturbed motion will be stable relative to θ , $\dot{\theta}$, ϕ , $\dot{\phi}$, and $\dot{\psi}$ if the following inequalities are satisfied:

$$(9) \quad c_{11} < 0 \quad (\text{or } c_{22} < 0),$$

$$(10) \quad c_{11}c_{22} - c_{12}^2 > 0.$$

When the sign of inequality (10) is changed to its inverse, according to the Kelvin-Chetayev theorem, the nonperturbed motion (1) will be unstable. And if, under the conditions of (9), the sign is changed to its inverse, the stability will depend on the sign of the expression⁴ $G = (g_{11} + g_{22})^2 + (a_{11}c_{22} + a_{22}c_{11}) - 2a_{12}c_{12} - 2\sqrt{(a_{11}a_{22} - a_{12}^2)(c_{11}c_{22} - c_{12}^2)}$. If $G > 0$, the characteristic equation of the Lagrange equations for (8) has two pairs of purely imaginary roots, and obtaining strict results regarding stability requires further investigation in this case. When $G < 0$, the nonperturbed motion (1) is unstable.

By using transition formula (5), the stability conditions (9) and (10) may, when $\bar{H} = 0$, $\bar{I} = 0$, $\bar{k} = 0$, and $\lambda = 0$, be used to derive the following sufficient conditions for the stability of the permanent rotations of a heavy solid body with one fixed point given an arbitrary mass distribution⁵: $\omega^2(A - B) - Mgx_0 > 0$, where $\omega^2 = Q^2/A^2$ and $s_1 = Mgx_0$. In the particular case when $\bar{k} = 0$, $\mu = 0$, $\lambda = 0$, $\bar{s} = 0$ and $b_1 = b_2 = b_3 = 0$, (10) is used to derive (which has been done by V. V. Lunev²) the sufficient conditions for the stability of permanent rotations around one of the principal inertia axes of a charged solid body that is attached at the mass center in a Lorentz force field.

Bibliography

1. Yakhyya, Kh. M., "New Solutions to Problem of Motion of Gyro in Potential and Magnetic Fields," VESTNIK MGU, No 5, 1985, pp 60-61.
2. Lunev, V. V., "Ob odnoznachnykh resheniyakh v zadachakh o dvizhenii tverdogo tela s zakreplennoy tochkoy v pole sil Lorentsa: Sb. nauchno-method. statey po teor. mekhanike" [Unique Solutions in Problems of Motion of Solid Body With Attached Point in Lorentz Force Field: Collection of Scientific Methodological Articles on Mechanics Theory], Moscow, 1981, No. 11, pp 147-154.
3. Rummyantsev, V. V., "Stability of Rotations of Heavy Solid Body," PMM, Vol 20, No 1, 1956, pp 51.
4. Karapetyan, A. V., "Stability of Steady Motions of Heavy Solid Body on Absolutely Smooth Horizontal Surface," PMM, Vol 45, No 3, 1981, p 507.
5. Rummyantsev, V. V., "Stability of Permanent Rotations of Solid Body Around Fixed Point," PMM, Vol 21, No 3, 1957, pp 339-346.

UDC 539.3

VIBRATIONS OF FLEXIBLE CURRENT-CARRYING CYLINDRICAL SHELLS IN MAGNETIC FIELD

907F0044A Kiev DOKLADY AKADEMII NAUK UKRAINSKOY SSR: SERIYA A--FIZIKO-MATEMATICHESKIYE I TEKHNICHESKIYE NAUKI in Russian No 8 Aug 89 (manuscript received 6 Jan 89) pp 25-28

[Article by Ya. A. Grigoryenko, corresponding member of Ukrainian SSR Academy of Sciences, and L. V. Molchenko, Institute of Mechanics, Ukrainian SSR Academy of Sciences, Kiev]

[Text] Problems of the interrelationship of various types of physical fields occupy an important position in the mechanics of solids and are of important scientific and applied significance. Taking the correlation of their fields into account is of considerable scientific interest and permits one to describe more fully the processes occurring in deformable solids and to determine new defects.

An approach to postulation and solution of axisymmetrical problems on the oscillation of flexible current-carrying shells affected by transient mechanical and electromagnetic fields, is proposed in the communication. A system of equations that describes vibrations of current-carrying shells in geometrically nonlinear postulation takes into account the effect of the coherence of dynamic and mechanical displacements of conducting bodies and the electromagnetic field. The Kirchhoff-Love hypothesis [1, 2] and also electromagnetic hypotheses adequate to it [3-5] are used in construction of this system.

Following the results of [5], let us use as the input equations the following equations, related to an undeformed median surface:

equations of motion

$$\begin{aligned} \frac{\partial N_1}{\partial \alpha} + \frac{1}{R} Q_1 + p_1 + n_1 + \rho f_1 &= \rho h \frac{\partial^2 u}{\partial t^2}; \\ \frac{\partial Q_1}{\partial \alpha} - \frac{1}{R} N_2 + p_3 + n_3 + \rho f_3 &= \rho h \frac{\partial^2 w}{\partial t^2}; \end{aligned} \quad (1)$$

$$\frac{\partial M_1}{\partial \alpha} - \left(N_1 - \frac{M_2}{R} \right) \theta_1 - Q_1 = 0;$$

equations of electrodynamics

$$-\frac{\partial B_3}{\partial t} = \frac{\partial E_2}{\partial \alpha}; \quad \sigma \left[E_1 - 0,5 \frac{\partial \omega}{\partial t} (B_2^+ + B_2^-) \right] = -\frac{B_2^+ - B_2^-}{\mu h}; \quad (2)$$

$$\sigma \left[E_2 + 0,5 \frac{\partial \omega}{\partial t} (B_1^- + B_1^+) - \frac{\partial u}{\partial t} B_3 \right] = -\frac{1}{\mu} \frac{\partial B_3}{\partial \alpha} + \frac{B_1^+ - B_1^-}{\mu h};$$

expressions for deformations

$$\begin{aligned} \varepsilon_1 &= \frac{\partial u}{\partial \alpha} + \frac{1}{2} \theta_1^2; \quad \varepsilon_2 = \frac{\omega}{R}; \quad \theta_1 = -\frac{\partial \omega}{\partial \alpha}; \\ \kappa_1 &= \frac{\partial \theta_1}{\partial \alpha}; \quad \kappa_2 = 0; \end{aligned} \quad (3)$$

relations of elasticity

$$\begin{aligned} N_1 &= \frac{Eh}{1-\nu^2} (\varepsilon_1 + \nu \varepsilon_2); \quad N_2 = \frac{Eh}{1-\nu^2} (\varepsilon_2 + \nu \varepsilon_1); \\ M_1 &= \frac{Eh^3}{12(1-\nu^2)} (\kappa_1 + \nu \kappa_2); \quad M_2 = \frac{Eh^3}{12(1-\nu^2)} (\kappa_2 + \nu \kappa_1). \end{aligned} \quad (4)$$

Here the coordinate surface of the shell is related to an orthogonal coordinate system α, β, u and w are components of displacements, $N_1, N_2, Q_1, M_1,$ and M_2 are forces and moments, θ_1 is the angle of rotation of the normal in plane $\beta = \text{const}$, $\varepsilon_1, \varepsilon_2, \kappa_1, \kappa_2$ are tangential and bending deformations, $B_{\pm 1}$ and $B_{\pm 2}$ are known tangential components of the flux density vector on the surface of the shell, B_3 is the normal component of the flux density vector, E_1 and E_2 are the components of the vector of the electric field intensity, J_{1CT} and J_{2CT} are the components of the density vector of the outside electric field, p_1 and p_3 are projections of the mechanical force, n_1 and n_3 are the projections of magnetic force, E is the modulus of elasticity, $h = \text{const}$ is the thickness of the shell, R is the radius of the shell, ρ is the density of the material, σ is electric conductance, and μ is permeability. Moreover, ρf_1 and ρf_2 are projections of the Lorentz volumetric force, which in the given case have the form [5]

$$\begin{aligned}
\rho f_1 &= hJ_{2cm}B_3 + 0,5\sigma h \frac{\partial w}{\partial t} (B_1^+ + B_1^-) - \sigma h \frac{\partial u}{\partial t} B_3^2 + \sigma h E_2 B_3; \\
\rho f_3 &= 0,5\sigma h [J_{1cm}(B_2^+ + B_2^-) - J_{2cm}(B_1^+ + B_1^-)] - \\
&- \sigma h \frac{\partial w}{\partial t} \left[0,25 (B_2^+ + B_2^-)^2 + \frac{1}{12} (B_2^+ - B_2^-)^2 + 0,25 (B_1^+ + B_1^-)^2 + \right. \\
&+ \left. \frac{1}{12} (B_1^+ + B_1^-)^2 \right] + 0,5\sigma h \frac{\partial u}{\partial t} B_3 (B_1^+ + B_1^-) + 0,5\sigma h E_1 (B_2^+ + B_2^-) - \\
&- 0,5\sigma h E_2 (B_1^+ + B_1^-).
\end{aligned} \quad (5)$$

The variables of the suggested approach are illustrated on the example of solving the boundary value problem for a flexible circular cylindrical shell.

Let us consider an aluminum shell of constant thickness, located in a permanent magnetic field $B = \{B_{10}, B_{20}, 0\}$ under the effect of the normal component of the mechanical force p_3 ($p_1 = n_1 = n_3 = 0$). An outside electric current of density $J = \{J_{10}, J_{20}, 0\}$ is applied to the plate circuits. Selecting $u, w, \theta_1, N_1, M_1, Q_1, B_3$ and E_2 as the main functions, the resolving system of magnetoelastic nonlinear equations is constructed in Cauchy form. The Newmark finite-difference scheme is used in the system to separate the time variables. The quasi-linearization method is applied to a homogeneous nonlinear system of differential equations. After the corresponding transformations, the solving system of equations assumes the form

$$\begin{aligned}
\frac{du^{(k+1)}}{dm} &= \frac{1 - \nu^2}{|\rho| Eh} N_1^{(k+1)} - \frac{\nu}{|\rho| R} w^{(k+1)} + \frac{1}{|\rho|} [-\theta_1^{(k)}\theta_1^{(k+1)} + 0,5 (\theta_1^{(k)})^2]; \\
\frac{d\theta_1^{(k+1)}}{dm} &= \frac{12(1 - \nu^2)}{|\rho| Eh^3} M_1^{(k+1)} + \frac{\nu}{2|\rho| R} [-\theta_1^{(k)}\theta_1^{(k+1)} + 0,5 (\theta_1^{(k)})^2]; \\
\frac{dw^{(k+1)}}{dm} &= -\frac{1}{|\rho|} \theta_1^{(k+1)}; \quad \frac{dN_1^{(k+1)}}{dm} = \frac{\rho h}{|\rho|} (\dot{u}^{t+\Delta t})^{(k+1)} - \frac{\rho}{|\rho|} f_1^{(k+1)}; \\
\frac{dE_2^{(k+1)}}{dm} &= -\frac{1}{|\rho|} (\dot{B}^{t+\Delta t})^{(k+1)}; \\
\frac{dQ_1^{(k+1)}}{dm} &= \frac{\nu}{|\rho| R} N_1^{(k+1)} + \frac{Eh}{|\rho| R^2} w^{(k+1)} - \frac{1}{|\rho|} p_3 + \\
&+ \frac{\rho h}{|\rho|} (\dot{w}^{t+\Delta t})^{(k+1)} - \frac{\rho}{|\rho|} f_3^{(k+1)}; \\
\frac{dM_1^{(k+1)}}{dm} &= \frac{1}{|\rho|} Q_1^{(k+1)} + \frac{1}{|\rho|} (-N_1^{(k)}\theta_1^{(k)} + N_1^{(k+1)}\theta_1^{(k)} + N_1^{(k)}\theta_1^{(k+1)}) -
\end{aligned} \quad (6)$$

$$-\frac{v}{|\rho|R} (-M_1^{(k)}\theta_1^{(k)} + M_1^{(k+1)}\theta_1^{(k)} + \theta_1^{(k+1)}M_1^{(k)});$$

$$\frac{dB_3^{(k+1)}}{dm} = -\frac{\mu\sigma}{|\rho|} [E_2^{(k+1)} + (\dot{\omega}^{t+\Delta t})^{(k+1)} B_{10} - (\dot{u}^{t+\Delta t})^{(k)} (-B_3^{(k)} + B_3^{(k+1)}) - (\dot{u}^{t+\Delta t})^{(k+1)} B_3^{(k)}] \quad (k = 0, 1, 2, \dots).$$

Here $m = |\rho|\alpha$, where $|\rho|$ is the dimensionless density of the shell material.

Let us select the boundary conditions in the form

$$\begin{aligned} u = 0; \quad Q_1 = 0; \quad M_1 = 0; \quad B_3 = -5 \cdot 10^{-2} \sin \omega t & \quad \text{at } \alpha = 0, \\ u = \omega = 0; \quad M_1 = 0; \quad B_3 = 0 & \quad \text{at } \alpha = S \end{aligned} \quad (7)$$

at initial condition

$$\begin{aligned} \vec{N}(\alpha, t)/t=0 &= 0; \\ \dot{u}(\alpha, t)/t=0 = \dot{\omega}(\alpha, t)/t=0 &= 0, \end{aligned} \quad (8)$$

where ω is the circular frequency and S is the length of the shell. The projections of Lorentz forces are given by expression (5).

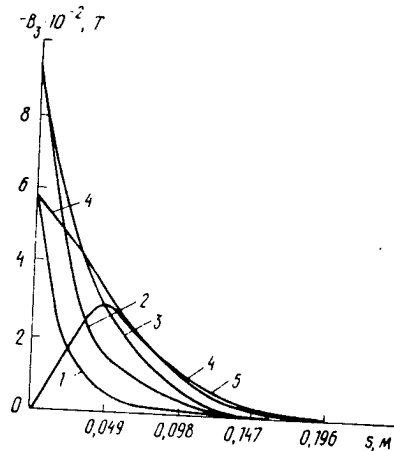

Distribution of Normal Flux Density Component
as Function of Time Δt :
1-- $2 \cdot 10^{-3}$; 2-- $4 \cdot 10^{-3}$; 3-- $6 \cdot 10^{-3}$; 4-- $8 \cdot 10^{-3}$; 5-- $1 \cdot 10^{-2}$ s

Let us assume that the parameters of the shell and of the material are as follows: $h = 2 \cdot 10^{-3}$ m, $S = 0.49$ m, $R = 0.4$ m, $E = 7.1 \cdot 10^{10}$ N/m², $\nu = 0.34$, $\sigma = 3.63 \cdot 10^7$ (ohms/m)⁻¹, $\rho = 2,670$ kg/m³, $\mu = 1.256 \cdot 10^{-6}$ H/m, $\omega = 3.1416 \cdot 10^6$ s⁻¹, $p_3 = -25$ N/m², $J_{20} = 5 \cdot 10^7 \sin \omega t$ A/m², and $B_{10} = 0.5$ T.

Boundary value problem (6) and (7) with initial conditions (8) is subsequently solved by the method of discrete orthogonalization. The solution of the problem is selected as the initial approximation without regard to the nonlinear terms. Solution of the nonlinear problem is selected on subsequent steps, which reduces the number of iterations required to find the solution.

Solution of the postulated problem was found on interval π . The time integration step was selected equal to $\Delta t = 5 \cdot 10^{-4}$ s and the typical effective time of the magnetic field was $\tau = 1 \cdot 10^{-2}$ s.

The distribution of the normal flux density component B_3 along the longitudinal coordinate of a cylindrical shell for the corresponding time layers is presented in the figure. Distribution B_3 is presented for half a cylinder with regard to the fact that the maximum variation of density occurs on the left end of the shell.

The results indicate the possibility of joint use of the Newmark scheme, the quasi-linearization method and the orthogonalization method in solving nonlinear boundary value problems of the magnetic flexibility of the theory of cylindrical shells during steady effects.

BIBLIOGRAPHY

1. Novozhilov, V. V., "Teoriya tonkikh obolochek" [The Theory of Thin Shells], Leningrad, Sudpromgiz, 1962.
2. Grigorenko, Ya. M., Ye. I. Besspalova, A. B. Kitaygorodskiy, and A. I. Shinkar, "Svobodnyye kolebaniya elementov obolocheynykh konstruktsiy" [Free Vibrations of the Elements of Shell Constructions], Kiev, Izdatelstvo "Naukova dumka", 1986.
3. Ambartsumyan, S. A., G. Ye. Bagdasaryan, and M. V. Belubekyan, "Magnitouprugost tonkikh obolochek i plastin" [The Magnetic Flexibility of Thin Shells and Plates], Moscow, Izdatelstvo "Nauka", 1977.
4. Dresvyannikov, V. I., "On the Theory of Thin Conducting Shells, Deformed in a Pulsed Magnetic Field of an Inductor," PRIKLADNYYE PROBLEMY PROCHNOSTI I PLASTICHNOSTI, No 23, 1983.
5. Molchenko, L. V., "Mathematical Fundamentals of Nonlinear Magnetoelasticity of Shell Theory," Kiev, 1988 (Preprint 88.47 of Institute of Mathematics, Ukrainian SSR Academy of Sciences).

UDC 534.2:532

INTERACTION OF TWO PARALLEL CIRCULAR CYLINDERS IN PERFECT LIQUID DURING
PASSAGE OF ACOUSTIC WAVE

907F0044B Kiev DOKLADY AKADEMII NAUK UKRAINSKOY SSR: SERIYA A--FIZIKO-
MATEMATICHESKIYE I TEKHNICHESKIYE NAUKI in Russian No 8 Aug 89
(manuscript received 23 Mar 89) pp 28-32

[Article by A. P. Zhuk, Institute of Mechanics, Ukrainian SSR Academy of
Sciences, Kiev]

[Text] Solids, located in a liquid in an acoustic wave field, experience a force effect from the direction of the liquid. As a result of interference of the incident wave and of waves reflected from the bodies, there is mutual disruption of the flowpast fields, which results in reaction of the solids. The interactions, a measure of which are time-constant components of hydrodynamic forces, are considered in this communication. These forces are determined as average values (by the period of the wave field) of the integral forces of influence of the liquid. Therefore, the pressure in the liquid must be calculated with accuracy up to component values, quadratic along the variables of the wave field.

Let us proceed from the model of a perfect compressible barotropic liquid and let us limit ourselves to the condition of potential flowpast. Let Φ be the potential of the velocity field, which is the sum of the potentials of the incident Φ_i and of reflected Φ_d waves. Then, following [1], the pressure p in the liquid will be calculated in the formula

$$p = -\rho_0 \frac{\partial \Phi}{\partial t} - \frac{1}{2} \rho_0 (\nabla \Phi)^2 + \frac{\rho_0}{2a_0^2} \left(\frac{\partial \Phi}{\partial t} \right)^2, \quad (1)$$

found with accuracy up to the component values, having the order of the squares of Mach number. The potential Φ is the solution of the linear wave equation

$$\Delta\Phi - \frac{1}{a_0^2} \frac{\partial^2\Phi}{\partial t^2} = 0, \quad (2)$$

where ρ_0 is the density of the liquid and a_0 is the velocity of the wave. Calculation of the time-constant value of the hydrodynamic force acting on the body is reduced to time averaging of the expression

$$F = - \int_S \rho N dS, \quad (3)$$

where N is a vector of the unit normal to surface S of the body. The potential Φ_d is determined from solution of the diffraction problem. The linearity of equation (2) permits one to use the principle of superposition in determination of the potential of the velocity field in the case of a system of bodies and, accordingly, to solve the problem of interaction for these bodies.

Let us consider two free parallel cylinders with radii a_s ($s = 1, 2$), which are located in an unbounded perfect liquid at distance l . Let us select as the main system the rectangular Cartesian coordinate system $Oxyz$. Let axis Oz be parallel to the axes of the cylinders and be in the same plane with the axes of the cylinder at an identical distance from them. Let us direct axis Ox in the direction of the second cylinder.

Let us be given the potential of the primary plane wave by the expression

$$\Phi_i = A \exp [i (\kappa x - \omega t)], \quad (4)$$

where A is amplitude, κ is the wave number, and ω is the circular frequency. Based on the foregoing, solution of the postulated problem reduces to determination of the potential of the total velocity field from solution of the linear problem of diffraction of a plane acoustic wave (4) on two free cylinders, to calculation of the pressure rates p (1) in the liquid by the potential of the field, and to calculation of hydrodynamic forces (3) of the effect of the liquid on each of the cylinders and to averaging of the latter by the period of the primary wave.

In mathematical postulation, the problem of scattering of a plane acoustic wave (4) on two free cylinders consists in determination of the solution Φ_d of wave equation (2), which satisfies the following boundary conditions on the surface of each cylinder in sum with the potential of the first layer:

$$\mathbf{U} \cdot \mathbf{N} = v_N \quad (5)$$

and the conditions of attenuation at infinity. The velocity vector of the corresponding cylinder is determined from the equation of motion

$$m\dot{\mathbf{U}} = - \iint_S p \mathbf{N} dS, \quad (6)$$

where m is the mass of unit length of the cylinder. Pressure p in expression (6) is calculated with sufficient accuracy by the formula

$$p = -\rho_0 \frac{\partial \Phi}{\partial t}, \quad (7)$$

in which the potential of the velocity field $\Phi = \Phi_i + \Phi_d$. Solution of the diffraction problem is constructed by the method of separation of variables in cylindrical coordinate systems [2-4]. Therefore, let us link the local cylindrical coordinate system $O_s r_s \theta_s z_s$ ($s = 1, 2$) to each cylinder, to which angle θ_s is read from axis Ox , axis $O_s z_s$ is directed along the axis of the s -th cylinder, while points O and O_s ($s = 1, 2$) are arranged in a plane perpendicular to axis Oz .

Let us write the potential Φ_i of the primary wave field in each of the local coordinate systems in the form of a series by cylindrical wave functions

$$\Phi_i^{(s)} = \sum_{n=0}^{\infty} A e^{(-1)^s i \kappa l_0} e_n i^n I_n(\kappa r_s) \cos n \theta_s \quad (s = 1, 2), \quad (8)$$

where $l_0 = l/2$; $e_n = 2$ ($n \geq 1$), $e_0 = 1$. Solution of the diffraction problem

(potential $\Phi_d = \sum_{s=1}^2 \Phi_d^{(s)}$) is also represented in the form of a series

$$\Phi_d^{(s)} = \sum_{n=0}^{\infty} A_n^{(s)} H_n^{(1)}(\kappa r_s) \cos n \theta_s \quad (s = 1, 2), \quad (9)$$

in which the coefficients of expansion $A_n^{(s)}$ ($s = 1, 2$) are determined from boundary conditions (5) on the surface of each cylinder. Using

addition theorems for cylindrical wave functions [2-4], the potential Φ_d of the secondary wave field in the s-th coordinate system is written in the following form:

$$\Phi_d = \sum_{n=0}^{\infty} [A_n^{(s)} H_n^{(1)}(\kappa r_s) + e_n S_n^{(s)} I_n(\kappa r_s)] \cos n \theta_s, \quad (10)$$

where

$$S_n^{(1)} = \sum_{m=0}^{\infty} (-1)^m A_m^{(2)} [(-1)^n H_{m-n}^{(1)}(\kappa l) + H_{m+n}^{(1)}(\kappa l)],$$

$$S_n^{(2)} = \sum_{m=0}^{\infty} A_m^{(1)} [H_{m-n}^{(1)}(\kappa l) + (-1)^n H_{m+n}^{(1)}(\kappa l)].$$

It follows from conditions of symmetry that the oscillation rate of the cylinders $U^{(s)}$ ($s = 1, 2$) is directed along axis Ox. Having integrated (6) with regard to expressions (7), (8) and (10), we find the following formula for calculation of it:

$$U_x^{(s)} = \frac{\eta}{a_s} [A e^{(-1)^s i \kappa l_0} e_1 i I_1(\kappa a_s) + A_1^{(s)} H_1^{(1)}(\kappa a_s) + e_1 S_1^{(s)} I_1(\kappa a_s)], \quad (11)$$

where η is the ratio of density ρ_0 of the liquid to the density ρ of the material of the cylinders. Multiplier $\exp(-i\omega t)$ is omitted in expressions (8)-(11).

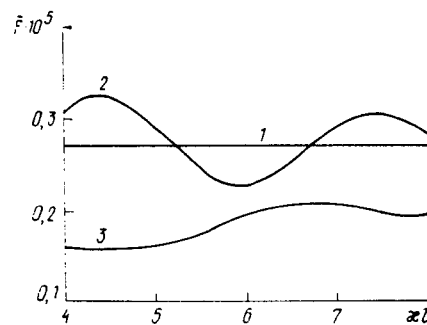

Figure 1. Dependence of Radiative Forces on Parameter $x l$ at $\kappa a = 1.0$

We find from boundary conditions (5), assuming that an infinite system of algebraic equations, similar to that presented in [5] (formula (2.9)), for determination of constants $A^{(s)}_n$ ($s = 1, 2$). The derived system of equations is uniquely solvable by the reduction method. The given degree of accuracy of the solution is provided by comparing the results for a sequentially increasing number of equations.

Only the real parts of the expressions for potentials (8) and (10) and velocities (11) of the motion of the cylinders must be used when using relation (1) to calculate the hydrodynamic forces (3). Let us indicate that variation of the position of the cylinders as a result of their vibrational motion must also be taken into account [5]; therefore, the partial time derivative $\partial\Phi/\partial t$ was replaced by the real part of the expression $d\Phi/dt - U_x \partial\Phi/\partial x$ in determination of the contribution of the first term of expression (1) to the hydrodynamic force. The term from $d\Phi/dt$ approaches zero upon time averaging of expression (3).

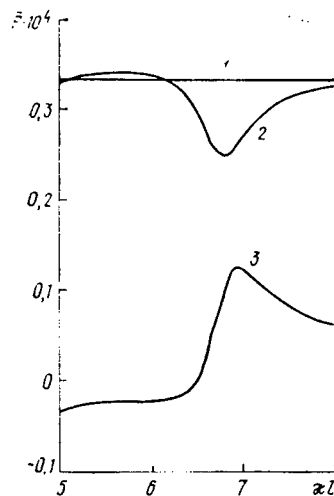

Figure 2. Dependence of Radiative Forces on Parameter αl at $\alpha a = 2.0$

Let us note that the problem, postulated in this communication, is solved approximately in [5] for the case when the wavelength is considerably greater than the radius of the cylinders and is less than the distance between them. It was possible with this hypothesis to find the solution in analytical form. The results, free of the indicated constraints, are presented in this communication. They were found by numerical methods from solution of the problem, formulated in correct postulation. The calculations were made for cylinders with radii $a = 0.0025$, placed in propanol ($\rho_0 = 785.4 \text{ kg/m}^3$, $a_0 = 1,247 \text{ m/s}$). The incident wave is characterized by amplitude $A = 0.9 \cdot 10^{-4} \text{ m}^2/\text{s}$, which corresponds to moderate power of the emitter for the considered frequency range.

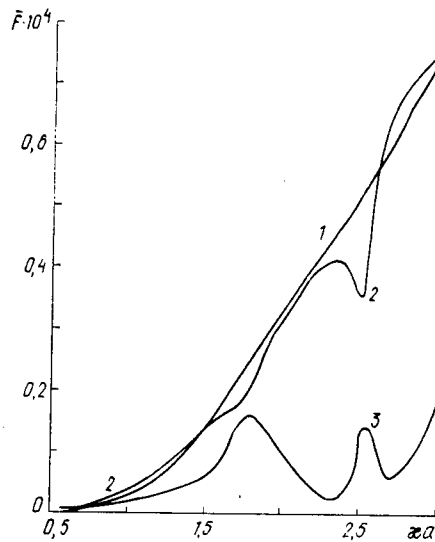

Figure 3. Dependence of Radiative Forces on Parameter ka at $l/a = 4$

Curves 1-3 in Figures 1-3 characterize the radiative forces acting on the length of the cylinder, equal to its radius. Curve 1 is related to a single cylinder, while curves 2 and 3 are related to the first and second cylinder in a system of two cylinders, respectively. The results for the case of cylinders suspended in propanol ($\eta = 1.0$) at $ka = 1.0$ and $ka = 2.0$, respectively, are presented in Figures 1 and 2. Deviation of curves 2 and 3 from curve 1 determines the interaction of the cylinders as a function of the distance between them (frequency is constant). It follows from analysis of the behavior of these curves that the former changes the radiative force acting on the second cylinder to a greater extent than the second cylinder changes the radiative force acting on the first in a system of two cylinders. The first cylinder seemingly attracts the second to it. The interaction of the cylinders is not monotonic in nature and decreases as the distance between the cylinders increases. The results of calculations for $\eta = 0.8$ and $l/a = 4.0$ are presented in Figure 3. The cylinders have a tendency toward a fast or slow relative approach as a function of parameter ka . This tendency is characterized by deviation of curves 2 and 3. The interaction of the cylinders increases as frequency increases.

Bibliography

1. King, L. V., "On the Acoustic Radiation Pressure on Spheres," PROCEEDINGS OF THE ROYAL SOCIETY, SERIES A, Vol 147, 1934.

2. Ivanov, Ye. A., "Difraktsiya elektromagnitnykh voln na dvukh telakh" [The Diffraction of Electromagnetic Waves on Two Bodies], Minsk, Izdatelstvo "Nauka i tekhnika", 1968.
3. Guz, A. N. and V. T. Golovchan, "Difraktsiya uprugikh voln v mnogovyaznykh telakh" [The Diffraction of Elastic Waves in Multiconnected Bodies], Kiev, Izdatelstvo "Naukova dumka", 1972.
4. Guz, A. N., V. D. Kubenko, and M. A. Cherevko, "Difraktsiya uprugikh voln" [The Diffraction of Elastic Waves], Izdatelstvo "Naukovo dumka", 1978.
5. Zhuk, A. P., "Interaction of Two Parallel Cylinders, Located One After the Other Along the Direction of Propagation of an Acoustic Wave," PRIKLADNAYA MEKHANIKA, Vol 23, No 8, 1987.

UDC 539.3

R-FUNCTIONS AND PROJECTION METHODS IN PROBLEMS OF TORSION OF PRISMATIC RODS WITH REGARD TO PARAMETERS OF THIN STRENGTHENING COATING

907F0044C Kiev DOKLADY AKADEMII NAUK UKRAINSKOY SSR: SERIYA A--FIZIKO-MATEMATICHESKIYE I TEKHNICHESKIYE NAUKI in Russian No 8 Aug 89
(manuscript received 13 Feb 89) pp 46-48

[Article by A. P. Slesarenko and Ya. P. Buzko, Institute of Problems of Machine Building, Kharkov, and Kharkov Engineering Economics Institute]

[Text] A new approach to solution of problems of torsion of complex-section prismatic rods with thin strengthening coating is suggested that permits one to find the approximate analytical solution of the given problems which contains the shear moduli G_0 and G_1 of the materials of the coating and rod as the parameters. The proposed method is based on joint use of R-functions and of the method of orthogonal projections, which results in solution of the corresponding system of algebraic equations with parameters G_0 and G_1 with respect to the unknown coefficients C_{ij} of the initial problem of torsion of rods of noncanonical cross-section.

The inverse problem of analytical geometry for a complex cross-section of the considered rod is solved accurately through the use of R-operations [1]. This permits one to introduce accurate information at the analytical level on the configuration of the rod in the structure of solving the boundary-value problem and of accurately satisfying the corresponding boundary condition, containing parameters G_0 and G_1 .

Let us assume that the main material of the rod is homogeneous and isotropic and that the strengthening layer is located on the external surface.

The stress function $u(x, y)$ in P. S. Pozhalostin's approximate postulation for the given problem satisfies the equation

$$\frac{\partial^2 u}{\partial x^2} + \frac{\partial^2 u}{\partial y^2} = -2 \quad (1)$$

at boundary condition

$$\left(u + \gamma \frac{\partial u}{\partial \nu_1}\right)\Big|_{\Gamma} = 0, \quad (2)$$

where $\gamma = \delta G_0 G_1^{-1}$; G_0 and G_1 are the shear moduli of the material of the strengthening layer G_0 and of the main material G_1 , δ is the thickness of the strengthening layer, and ν_1 is the inner normal to contour Γ .

Let us assume that the thickness of the strengthening layer is negligible compared to the cross-sectional dimensions of the rod and to the radius of curvature of the contour of the layer. Let us transform condition (2) to the form

$$\left(\frac{\partial u}{\partial \nu_2} + \beta u\right)\Big|_{\Gamma} = 0, \quad (3)$$

where $\beta = \gamma^{-1}$ and ν_2 is the outer normal to contour Γ .

Let us consider a prismatic rod of noncanonical cross-section. The structure of solution of problem (1) and (3) for stress functions that accurately satisfy condition (3) is represented in the form [1]

$$u(x, y, \beta) = \sum_{i,j}^n C_{ij}(\beta) X_{ij}(x, y), \quad (4)$$

where $X_{ij}(x, y) = \varphi_{ij} - \omega D_1 \varphi_{ij} + \omega \beta \varphi_{ij}$, $D_1 \varphi_{ij} = \frac{\partial \varphi_{ij}}{\partial x} \frac{\partial \omega}{\partial x} + \frac{\partial \varphi_{ij}}{\partial y} \frac{\partial \omega}{\partial y}$;

$\varphi_{ij} = P_i(x) P_j(y)$ are Chebyshev polynomials. Function ω in formula (4)

satisfies the condition $\omega|_{\Gamma} = 0$; $\omega > 0$ (x, y) $\in \Omega$; $\frac{\partial \omega}{\partial \nu_1}\Big|_{\Gamma} = 1$ and is

constructed by means of R-operations according to the recommendations of [2].

Using the method of orthogonal projections [3], we find a system of equations for determination of coefficients $C_{ij}(\beta)$

$$\iint_{\Omega} [\Delta V + \beta \Delta \psi + 2] \eta_{ks} d\Omega = 0; \quad k + s = 0, 1, \dots, n, \quad (5)$$

where

$$\begin{aligned} v(x, y, C_{ij}) &= \sum_{i,j} C_{ij}(\beta) (\varphi_{ij} - \omega D_1 \varphi_{ij}), \\ \psi(x, y, C_{ij}) &= \sum_{i,j} C_{ij}(\beta) \varphi_{ij} \beta \omega, \end{aligned} \quad (6)$$

$\eta_{ks}(x, y) = \Phi_{1k}(x) \Phi_{2s}(y)$ is the complete system of functions, for example, Chebyshev polynomials, trigonometric polynomials and so on can also be taken

$$\eta_{ks}(x, y) = \varphi_{ks}(x, y) = P_k(x) P_s(y),$$

where $P_k(x)$ and $P_s(y)$ are Chebyshev polynomials.

Having substituted functions (6) into system of equations (5), we find a system of equations in the form

$$\sum_{i+s=0}^n C_{ij}(\beta) (A_{ijks} + \beta B_{ijks}) = E_{ks}, \quad (7)$$

where

$$\begin{aligned} A_{ijks} &= \iint_{\Omega} \Delta X_{ij}^{(1)} \eta_{ks} d\Omega; \quad k + s = 0, 1, \dots, n, \\ B_{ijks} &= \iint_{\Omega} \Delta X_{ij}^{(2)} \eta_{ks} d\Omega; \quad E_{ks} = 2 \iint_{\Omega} \eta_{ks} d\Omega, \\ X_{ij}^{(1)} &= \varphi_{ij} - \omega D_1 \varphi_{ij}; \quad X_{ij}^{(2)} = \omega \varphi_{ij}. \end{aligned}$$

Let us find the solution of system (7) in the form $C_{ij}(\beta) = \sum_{k+s=0}^n \Delta_{ks}^{(ij)}(\beta) [\Delta(\beta)]^{-1}$,

where $\Delta^{(ij)}_{ks}(\beta)$ are the corresponding algebraic complements for elements $(A_{ijhs} + \beta B_{ijhs})$, $\Delta(\beta) = \|\| A_{ijhs} + \beta B_{ijhs} \|\|$.

Thus, solution of problem (1) and (3) in the form of (4) with parameter $\beta = \beta(G_0, G_1)$ yields the possibility of finding parametric function $C = C(G_0, G_1)$ for the first time for stiffness to the torsion of a rod of noncanonical cross-section with thin strengthening coating.

Let us consider as an example problem (1) and (3) for a rectangular rod $(-a \leq x \leq a; -b \leq y \leq b)$. Let us represent the analytical structure of solution of problem (1) and (3) that accurately satisfies condition (3) for any value of parameter β in the form

$$u(x, y, \beta) = \sum_{i,j}^n C_{ij}(\beta) X_{ij}(x, y), \quad (8)$$

where

$$\begin{aligned} X_{ij}(x, y) &= \Phi_{1i}(x) \Phi_{2j}(y), \\ \Phi_{1i}(x) &= P_i(x) - \omega(x) \frac{dP_i(x)}{dx} \frac{d\omega(x)}{dx} + \beta \omega(x) P_i(x), \\ \Phi_{2j}(y) &= P_j(y) - \omega(y) \frac{dP_j(y)}{dy} \frac{d\omega(y)}{dy} + \beta \omega(y) P_j(y), \\ \omega(x) &= (a^2 - x^2)(2a)^{-1}; \quad \omega(y) = (b^2 - y^2)(2b)^{-1}, \end{aligned}$$

and $P_i(x)P_j(y)$ are Chebyshev polynomials.

At $a = b = 0.5$ and $\gamma = 1$ for the stress function in the first approximation, we find

$$u(x, y) = \frac{3}{7} (1,25 - x^2)(1,25 - y^2). \quad (9)$$

In this case, in formula (8) $\Phi_{10} = \Phi_{20} = 1$; $\omega(x) = 0,25 - x^2$; $\omega(y) = 0,25 - y^2$.

From formula (9) for the torsional stiffness of the rod, one finds $C = 1.166$ and from the data of [4], one finds $C = 1.162$.

If β is left as the parameter and $a = 1$, $b = 0.5$, then using formula (8), the first approximation for the stress function is found in the form

$$u(x, y, \beta) = C_{00}(\beta) \left[1 + \beta \frac{(1-x^2)}{2} \right] \left[1 + \beta \left(\frac{1}{4} - y^2 \right) \right]. \quad (10)$$

From equation (7) we find

$$C_{00}(\beta) = 12 [\beta (18 + 5\beta)]^{-1}.$$

Formula (10) permits one to calculate in the first approximation the dependence of the torsional stiffness of the rod on parameter β

$$C = 8(6 + \beta)(3 + \beta)[3\beta(18 + 5\beta)]^{-1}. \quad (11)$$

We find for $\beta = 1$, $\beta = 1.25$, and $\beta = 2.5$ from formula (11): $C = 3.246$, $C = 2.710$, and $C = 1.634$, respectively.

The following results were found for the torsional stiffness of the rod, using a computer and data of [4]: $C = 3.224$, $C = 2.690$, and $C = 1.569$, respectively.

Let us illustrate the effectiveness of using functions of type (11) when solving the inverse problems of torsion of rectangular rods with thin strengthening coating. For example, one must select parameter β of a thin strengthening coating such that the torsion stiffness of the rod be equal to $C = 3.224$. Using formula (11), we find for determination of parameter β the equation

$$5.045\beta^3 + 12,762\beta - 18 = 0.$$

In this case $\gamma_1 = \beta^{-1}_1 = 1.008$; $\gamma_2 < 0$ has no physical meaning.

Thus, the proposed approach generally permits one to find for the first time the parametric dependence for the torsional stiffness of a rod $C = C(\beta)$, which transforms to a new qualitative level the solution of the problem of optimal selection of a thin strengthening coating for complex-section prismatic rods.

BIBLIOGRAPHY

1. Rvachev, V. L., "Teoriya R-funktsiy i nekotoryye yeye prilozheniya" [The Theory of R-Functions and Some of Its Applications], Kiev, Izdatelstvo "Naukova dumka", 1982.
2. Rvachev, V. L. and A. P. Slesarenko, "Algebra logiki i integralnyye preobrazovaniya v krayevykh zadachakh" [The Algebra of Logic and Integral Transforms in Boundary-Value Problems], Kiev, Izdatelstvo "Naukova dumka", 1976.
3. Demidovich, B. P., I. A. Maron and E. Z. Shuvalova, "Chislennyye metody analiza" [Numerical Methods of Analysis], Moscow, Fizmatgiz, 1963.
4. Rvachev, V. L. and I. V. Goncharyuk, "Krucheniye sterzhney slozhnogo profilya" [The Torsion of Complex-Section Rods], Kharkov, Polytechnical Institute, 1973.-

UDC 629.114.6

LA52 AUTOMATIC ASSEMBLY LINE

18610390B Moscow AVTOMOBILNAYA PROMYSHLENNOST in Russian No 1, Jan 89 pp 29-30

[Article by G.A. Amnuel, MKTEIavtoprom [not further identified]: "LA52 Automatic Assembly Line"]

[Text] MKTEIavtoprom has developed and introduced at KamAZ [Kama Automobile Factory] an automatic line for assembly of the crank-piston unit for the KamAZ engine. The assembly line is protected by five author's certificates (USSR Author's Certificates 655500, 695910, 952507, 1000214 and 1009691). The specifications of the assembly line are given below:

Maximum output, units/hr	300
Loading coefficient	0.8
Operation cycle, s	12
Number of operation positions	9
Component transportation system	Automatic grab units, no satellites
Installed capacity, kW	60
Control system	Special controller
Dimensions, m	12 × 6.8 × 4.7
Weight, tons	18.3

The line is operated by one person.

A special controller on K511 series integrated microcircuits is used for control, operating according to a rigid time cycle.

Figure 1 is a diagram of the assembly line with the main mechanisms. It operates as follows.

Rinsed pistons are dispensed down a gravitational tray to a shutoff device which feeds them (one unit at a time) to the carriage of the conveyor of electric furnace 1. The piston is heated in the furnace to 360-390 K (90-120°C) and is placed by a pusher onto the table of orientation mechanism

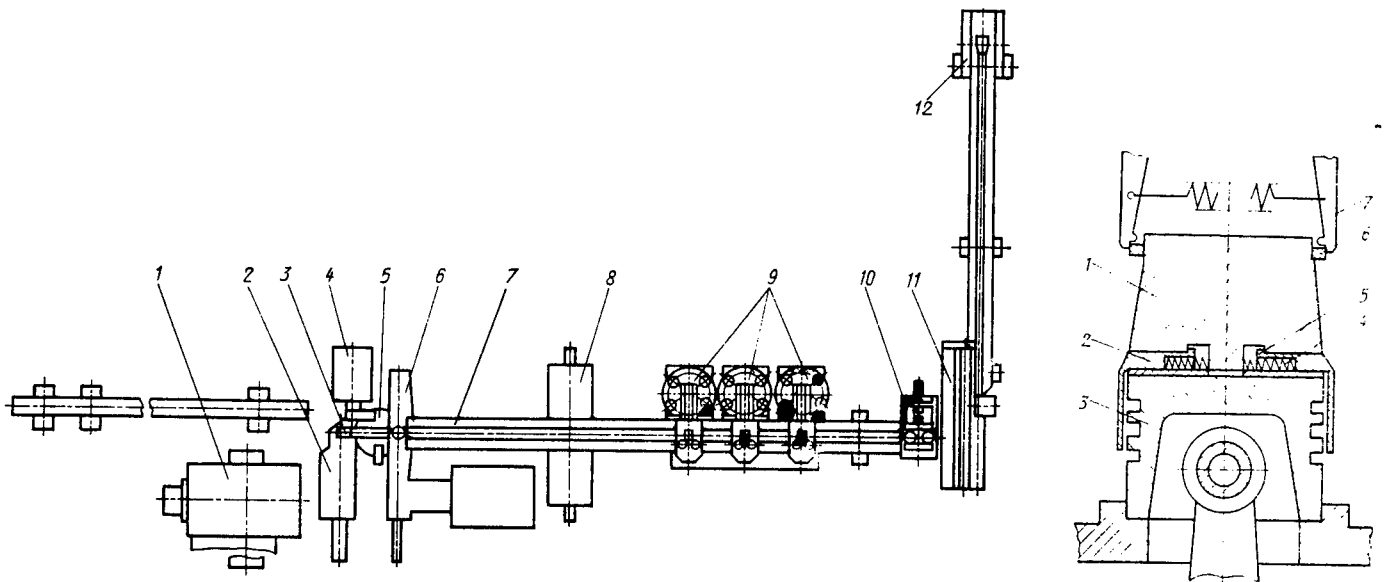

Figure 1.

2. The orientation unit is lowered and presses the piston by a cup to the table. At the same time, a cam is inserted between the bosses of the piston and rotates the piston. The correct position of the piston is controlled by the necks in the piston head for valve installation. If the position is wrong the piston is turned 180° and checked again. The orientation unit is then lifted and the table with the piston oriented correctly is rotated 180°. Manipulator 3 is lowered, takes the piston with the grip and, as it moves upward, removes it from the orientation mechanism table. The manipulator hand rotates 180°, turning the piston with its head down and, moving down, inserts the piston into the cradles of conveyor system 7.

Cranks (also one-by-one) are delivered from the storage dispenser into the grip of manipulator 4 and held by it. The manipulator arm rotates 180° and is lowered, inserting the connecting-rod (lower) end into the receiver of feed mechanism 5. The grip is opened and the manipulator returns to its initial position. The faceplate of the feed mechanism table with four receivers mounted on it rotates 90°; a receiver rises, inserting the connecting rod into the assembly (insertion) zone of pins. The pins are delivered into the prism from a coil stack by a chain elevator and lifting devices to the area where (the cradles of mechanism 6) the oriented piston has been placed by conveyor system rod 7 before the receiver with the connecting rod is lifted here. A support is placed next to the connecting rod to prevent its displacement when broaching with the mandrel. As the mandrel is introduced, the piston and connecting rod are raised. The mandrel axis becomes the basis for assembling them. After the mandrel is introduced, the receiver is lowered and two supports are brought close to the connecting rod to limit its movement when a pin is inserted. A pin pushes the mandrel

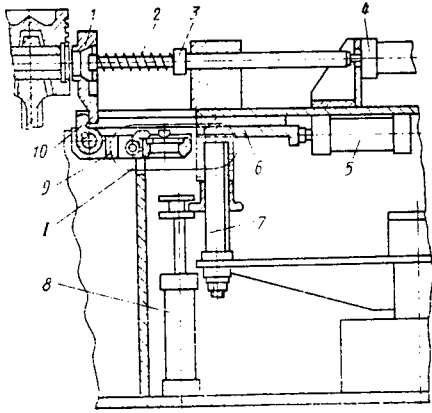

Figure 2.

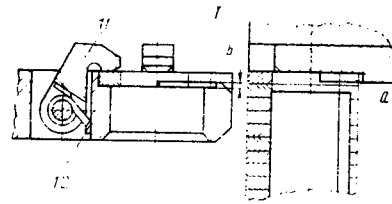

Figure 3.

out and occupies its place. The mechanisms are all then returned to their initial positions.

The conveyor system rod moves the semi-assembled unit to position 8 of the lock ring installation and is fixed there. The power cylinder 5 (fig. 2) moves slide gate 6 forward, which catches by its recess a the upper ring supported by pressure from pneumatic cylinder 8; it feeds the ring to rotary receiver 9. The ring gets under catch dogs 11 that keep it in recess b by springs 12, preventing movement of the ring from the rotary receiver during the reverse stroke of the gate. During this stroke the pressure to the ring packet is removed (by relieving pressure in the piston cavity of pneumatic cylinder 8).

After the gate returns to its initial position, the rotary receiver with rest 10 turns 90° and holds head 1 in its initial position. Spring 2 inserts the head into the piston opening for the piston pin; the rotary receiver with the lock ring held by spring-supported catch dogs moves the ring to the endface of the head from the side of the larger-diameter conical opening, matching the axes of the ring and the opening. Power cylinder 4 moves pusher 3, which deflects the catch dogs and pushes the lock ring through the conical opening until it falls into the piston groove. All the mechanisms then return to their initial positions.

When there are no lock rings on the mandrel 7 of the dispenser, the empty mandrel is automatically replaced by a full one.

In the subsequent positions 9 (see fig. 1) piston rings are installed: an oil-removing ring and two compression rings. The gate from the dispenser delivers a piston ring which hangs above the conical portion of the tab head. The head is held in place by grips. The head is lowered and installed on the

piston. The grips then move apart, releasing the head and letting through the ring pushed by pusher-levers. The ring slides over the cone and the head tabs until falling into the appropriate piston groove.

As mentioned earlier, the tool for insertion of piston rings is a tab head. It includes a conical element 1 (fig. 3), the endface of which has rigid thin-walled cylindrical segments (tabs) 2 that can move by elastic forces of a pretensioned piston ring. As the head with the piston ring is lowered onto piston 3, the tabs under the action of springs 4 find themselves on rests 5, providing a setting clearance between inner surfaces of the tabs and the outer piston surface. Lever-pushers 7 then move down, shifting piston ring 6 over the conical element surface. In the process the ring becomes distended. When the ring moves over the tabs, springs 4 contract and the inner surface of tabs comes in contact with the piston surface. In case the head and the piston are not coaxial, the elastic forces of the distended piston ring acting through the tabs shift the head, producing self-centering. As lever-pushers continue to move, they push the piston ring into the piston groove.

When the insertion of piston rings is completed, a cut mandrel with a mobile lower part is inserted into the opening of the lower head of the connecting rod. The assembly is fixed in place and the head of a two-spindle power nut-driver is brought to it. They unscrew the nuts of head cover mounting, leaving 1.5-2 turns of the threading. The heads then return to their initial position and the mobile element of the cut mandrel moves cover along the connecting rod axis.

The conveyor system rod places the assembled unit on the cradles of manipulator 11. One of them can move about the horizontal axis. A carriage with a mandrel is inserted into the piston pin opening. One of the cradles then turns, allowing the carriage with the assembled unit to move the product accumulator 12. After passing through limiting dogs on the accumulator, the carriage is relieved of the assembled unit and returns to its initial position. When the accumulator is overfilled, the line stops.

The processes inserting the lock rings of the piston pin and inserting piston rings are substantially different from previous techniques used in these operations. In particular, the insertion of lock rings prevents malfunctions in ring delivery that happen when it is oriented and readjusted by gravity. The method also eliminates instability of the ring in an angular position and relative to the axis of the conical mandrel. The process does not require a precise centering of the piston and the mandrel, which is necessary when the ring is moved over the piston by a mandrel shaped as an opening collet or a rigid conical mandrel with a skirt or with preliminary opening of the rings. In addition, the tab head can operate at various piston diameters.

Operational experience with similar assembly lines has shown these design concepts to be effective. They are recommended for equipment used to assemble crank-piston groups of any internal combustion engines or compressors.

UDC 621.865.8-519

A ROBOT FOR EQUIPMENT LOADING

18610390C Moscow AVTOMOBILNAYA PROMYSHLENNOST in Russian No 1, Jan 89 p 31

[Article by K.B. Alekseyev, V.I. Matveyenko and Yu.G. Staroverov, Engineering College/Factory, ZIL [Automobile Factory imeni Likhachev]: "A Robot for Equipment Loading"; the first two paragraphs are a boldface introduction]

[Text] Automation of auxiliary operations such as loading-unloading of equipment, transfer of components, cartridging, etc., is a primary aspect of industrial progress. It is not always possible to utilize the main automation tool — industrial robots — for such operations. For example, on those automatic lines where components remain oriented throughout the processing cycle robots are profitable. However, if components are received for processing in an unoriented flow, using robots is economically inefficient, because it requires either preorienting components manually or with all kinds of dispensers that can only position components of a simple shape and are narrowly specialized devices with difficult readjustment.

The application scope of industrial robots for auxiliary operations can be expanded by introducing sensors. With these devices robots become capable of feeding components of various types. One has only to modify the program or introduce minimal changes to the equipment (for example, replacing the robot grip), to satisfy the needs of flexible manufacturing.

An industrial vision system is a highly informative sensor device. It can identify the type of component and its orientation and coordinates in space. Progress in microprocessor and control microcomputers and the gradual reduction in their cost make the use of adaptive robots cost-effective as well as technologically feasible. The factors at work here include reduced cost of equipment in case of a change of the list of articles manufactured, additional capabilities for visual monitoring and measurement of component dimensions and a higher equipment reliability in proportion to fewer mechanical elements.

There are two approaches to the use of adaptive robots sorting out a heap of components. One is to determine the orientation of components and their position by an industrial vision system at the time when the component is still in its packaging, from which the robot then grips and extracts it. Evaluating the position of a component means defining its six coordinates. It is a complex three-dimensional problem requiring stereoscopic systems and considerable amounts of computer time to accomplish. In addition, since there is limited access to components in a heap, even if the coordinates are known, gripping the component from a packaging box may be difficult.

The second approach is more practical: a robot first extracts a component "blindly" and places it into an intermediate position (a plane) where it can be held in one of a number of stable positions. (Now on a plane, simpler industrial vision systems can be used to identify the component's coordinates.) A robot grips a component from the plane and, after orienting it, loads it into the equipment.

For a practical implementation of the latter method, experts at the ZIL Engineering College/Factory have created a robotic engineering system that is made up a TUR-10K industrial robot, an industrial vision system based on a PZS [charged-coupled device] television camera, an Elektronika-60 microcomputer, an infrared illumination device and a magnetic grip with sensors that allow the system to work with most ferromagnetic engineering components.

Two types of grips are used. One type is devised mainly to handle components of a simple shape. It is a magnet with a floating cylindrical core. It is controlled by a program from a UKM-772 system, allowing the system to weigh components after extracting them from the box and ensure that only one is kept in the grip. The grip of the second type combines the functions of a magnetic grip and a mechanical grip with plane-parallel lips and can be used to move components of a complex shape. The design of the core is such that only one piece will be handled at a time, because with a high probability the magnetic flux closes only through a single component. From an intermediate position a component is taken for orientation mechanically. At that point the winding of the electric magnet is not energized. Tactile sensors and component-presence sensors are installed on the grips for adaptation.

A binary industrial vision system is used, which operates with just two image brightness gradations. Compared with half-tone systems these devices are less costly and can operate in real time. A battery of fast-speed recognition algorithms have been developed for them which determine the parameters of the position of single or overlapping components. An effective use of this type of industrial vision is possible only in deterministic illumination conditions with a high "object-background" contrastivity.

A "transparency" illumination is used to improve image contrastivity. The intermediate position where the components are kept after being extracted from the package is an infrared illuminator. The system retains its operability even when outer light varies or when components are soiled — important factors in a real industrial environment.

The system includes a medium-format PZS television camera with discreteness of 288×232 . Experiments have shown it to provide component coordinate measurement accuracy of not less than 0.2% of the width of the field of vision. Complete image processing time is 0.3-0.7 s; it is combined with manipulator movement, so that the vision system does not hold up the robot operation.

The system has been tested on component sorting and cartridging. The mean time of extracting a component, orienting it and putting it into a cartridge was approximately 15 s. The robot successfully sorted out components piled in a heap and not hitched together in a box. Experiments showed that when components in the upper layer not covered by other components occupy at least 30% of the total heap area the probability of successful grip after the first attempt is at least 80%.

For rapid readjustment of the system to handle components of a different type a self-training program is used, which automatically compiles a standard description of a component submitted to the industrial vision system. The reciprocal coordination of robot positioning systems and industrial vision systems in case of a change of the relative position of the television camera and the robot is provided by an adjustment program, which completes its operation automatically within 2 min.

UDC025.4:744.43:658.562:006.354

ESKD [UNIFIED DESIGN DOCUMENTATION SYSTEM] CLASSIFIER: THE BASIS FOR CREATION OF SAPR [COMPUTER-ASSISTED DESIGN SYSTEM] FOR COMPREHENSIVE EXECUTION OF RECURRING TASKS IN THE DEVELOPMENT OF NEW TECHNOLOGY, PROCESSES AND INDUSTRIAL PROCESS CONTROL

18610406A Moscow STANDARTY I KACHESTVO in Russian No 2, Feb 89 pp 74-77

[Article by A.I. Aleksandrov, Krasnogvardeyets PO [Production Association]: "ESKD [Unified Design Documentation System] Classifier: The Basis for Creation of SAPR [Computer-Assisted Design System] for Comprehensive Execution of Recurring Tasks in the Development of New Technology, Processes and Industrial Process Control"]

[Text] The ESKD [Unified Design Documentation System] Classifier [K.ESKD] combined with the Technological Classifier of Components in Engineering and Instrument Making [TKD], the Classifier of Technological Operations in Engineering and Instrument Making [KTO] and the related requirements of general technical standards of SRPP [not further identified], ESTD [Unified System of Technological Documentation], ESTPP [Unified System of Technological Preparation of Production], GSI [State System for Ensuring Unification of Measurements] and others are called upon to innovate drastically routines in the creation of new technologies and industrial processes of planning and scheduling for manufacturing and production.

The process of introduction of K.ESKD will largely depend on the extent of understanding and support it will receive in industries and at enterprises where local partial decisions concerning computer-assisted design are already being developed or are operational. These include such systems as "Designer" [K], "Process Engineer" [T] and "Production" [P]. These questions will also be solved at enterprises faced with the question of whether to undertake projects of SAPR of these types independently or in cooperation with other organizations. It is a difficult issue that involves major financial outlays on software development, acquisition of computer technology [TSVT], selection and training of personnel to operate with this equipment — designers,

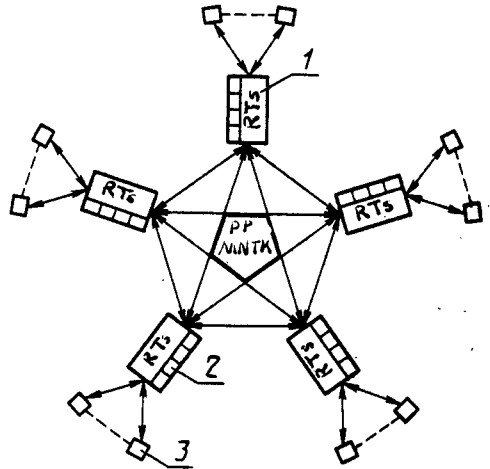

Figure 1. Structural diagram of "PP" MNTK and RTs: 1 — regional centers; 2 — subscriber workstations; 3 — city enterprises; 4 — peripheral subscriber workstations for enterprises in the city and the region.

process engineers, mathematicians, programmers, computer operators, mechanics, etc.

Creation of K, T and P SAPR systems at individual enterprises is a difficult proposition. For most medium-sized and small enterprises it is an unbearable burden.¹ The chief difficulty is shortage of labor, materials and financial resources. The activity could be helped and accelerated if it is endowed with the status of a scientific-technological program with centralized financing. Centralized introduction of GOST 2.201-80, KTO [not further identified], TKD [Technical Classifier of Components], ESKD standards and other general technological standards covering recurring processes of creation and fabrication of new technologies should be based exclusively on shared-use TSVT with a common information-reference database for all industries.

Organizationally, this could be presented as an interindustry scientific-technical complex for development and testing of application software packages [PPP]: "Software Package" MNTK [Interindustry Scientific-Technical Complex] and Regional Centers [RTs] with a fleet of TSVT and PPP for them (see fig. 1). The regional centers should be set up mainly in industrially and technologically developed parts of the country (in Moscow, Leningrad, Kiev, Novosibirsk, Sverdlovsk, etc.) with a capability for working with TSVT both at the center, at subscriber terminals and at subscriber in-house workstations at their enterprises in the region.

At the present time a "Personal Computers" MNTK [PEVM] has been created and is functional in the USSR. Its objective is to develop and design personal

computers with peripheral devices on a microelectronic basis and to produce them on an industrial scale for consumers.

By the end of the Twelfth Five-Year Plan Period, more than 500 million personal computers are planned to be manufactured for the industry [as printed]. In the next five-year period the output of personal computers is to be increased several-fold. However, they will be able to work only if there are programs or PPP for execution of certain recurrent tasks. An essentially new approach is needed for the utilization of this advanced and, one must say, expensive technology. The new approach is in fact the creation of MNTK which will be responsible for development of software and methods of software use for all engineering industries that have to accomplish similar recurring tasks with unified requirements for executing them in compliance with GOST 15.001-73, ESKD, ESTD, ESTPP, GSI and other general technical standards, including OKP [All-Union Product Classifier] for standardized products; these efforts will be invested on a scientific basis with concentration of scientific and engineering forces and in compliance with the requirements of national standards.

These software packages will make it possible to:

- formulate requests, invoice-requests, contracts, specifications, textual, graphic and diagrammatic design, process-engineering and other technical documents (minutes, findings, protocols, decisions, etc.);
- develop a complete or compartmentalized network schedule covering stages and phases in development and introduction of new technologies and processes;
- have universal and enterprise-specific technical requirements for components and assembly units [DSE] to be established during machine design and manufacturing process engineering;
- test the feasibility of combining DSE to an assembly unit according to attachment dimensions in the geometric configurations.

An important condition for "Software Package" MNTK work is analysis of existing or planned local decisions in K, T and P SAPR and utilization of optimal solutions. There is some experience to this effect in the industry. Examples include the KAPRI system at the Institute of Atomic Energy imeni I.V. Kurchatov; the T SAPR (computerized design of engineering processes for machining of "body-of-revolution" class of components) at Klimovsktekmash [not further identified]; the Raschet [Calculation] system at KamAZ [Kama Motor Factory]; the PRAM-1.1 system and others.

The list of scientific and technical products² to be developed by the "Software Package" MNTK for subsequent shared use in projects on K, T and P SAPR should include the following application program packages:

■ for transfer of K.ESKD (classes 28, 29, 30, 71-75 and 76), KTD and KTO to machine language. The computer is to replace manual coding of DSE, keep track of applicability at any organization level (local enterprises, industries and interindustry level). This involves complete unification of components of products in basic and auxiliary industries, combined with decisions on manufacturing processes.

This software package accomplishes functions in:

- coding original DSE according to the designer's assignment. The computer encodes DSE in terms of specific characteristics after conducting a search for analogous characteristics in its memory and in other RTs. If it finds such characteristics in the memory, it assigns only the code of the requesting enterprise, while the remainder of the DSE notation is left unchanged. The applicability card kept in the computer memory includes a notation as to who employs the respective decision and what is the amount of industrial introduction. The objective is to develop specialized production at industrywide and interindustry levels. In absence of analogues, the computer assigns a species notation with the current registration number;
- developing single-group and typical engineering processes, assigning DSE notations and taking into account all operations and transitions practiced by the enterprise whose assignment is executed by the computer.

■ for information on material and technical resources created by the industry and on current-awareness sources of information on new raw and processed materials and complement items introduced in the industry with data on storage amounts available at wholesale warehouses, availability in lease stores and overstock backlogs at enterprises, as well as complete stock information from receipt to use.

At the same time, each enterprise will have, in this package, information of its own on raw and processed materials and complement product items permitted for use with their inventory and circulation data.

The codes of raw and finished materials and complement articles in this PPP should match the nomenclature classification codes assigned to them in OKP. In addition to the planning and accounting uses of these codes, they must also be used to identify classified products in accordance with USSR State Standard GOST 2.201-80.

Currently, designers of auxiliary products of IET [not further identified] type have developed for current-awareness information a circular entitled "Procedures for Distribution of Current-Awareness Information on IET on Machine-Readable Media Covering Products on Lists of Articles Allowed for Use in Development and Modernization of Equipment of National Economic Importance" and distributed it (of course, for a fee) to enterprises to be

used by way of rerecording current-awareness information from original machine-readable media produced by IET designers onto machine-readable media of the user enterprises. This raises the question as to what should be done by those enterprises that do not have TSVT and machine-readable media. This is precisely what MNTK is needed for.

All current and current-awareness information on raw and finished materials and auxiliary products, once received through MNTK by RTs, will allow every enterprise on a group basis to utilize this information for a much smaller fee, which will make up a component of the total payment for services provided by RTs:

- for information covering nonstandardized technical facilities for measurement, testing, monitoring, mechanization and automation of single and typical engineering processes as practiced by enterprises with brief technical characteristics and description of the purposes, the set of technical documentation and prices.

With this information, enterprises will be able to greatly reduce the time for introduction of new technologies by utilizing these facilities for their own projects;

- for standard technological equipment used by enterprises with specifications for all kinds of processing, formation, assembly and checking. Worksites, classified according to use in machine-processing, galvanic, thermic, shape-forming, assembly, etc., workshops and sections; recordkeeping and circulation;

- for tools with inclusion of specifications, recordkeeping and circulation (operation, maintenance and disposal);

- for standard measurement instruments circulating in the industry;

- for work rating for designers, process engineers and technological norms for execution of operations and transitions under USSR State Standard GOST 3.1114-69;

- for planning and scheduling launch of products into manufacturing according to all items of production plans: current, weekly, 10-daily, monthly, quarterly, annually and long-term.

In addition, it is proposed that software packages be developed for each enterprise (if necessary) to reflect the specifics of industrial and economic activity to be handled by the particular enterprise. For example, decisions on wages, etc., and other forms of general specific problems (not covered by the descriptions) as they affect development of new technologies, processes and manufacturing.

The creation of the "Software Package" MNTK and RTs involves a complex set of actions in implementing scientific and technological programs that require support by central scientific and technical agencies, such as GKNT SSSR [USSR State Committee for Science and Technology], Gosstandart SSSR [USSR State Committee for Standardization] and engineering industries both in terms of general support of the idea and as an initial financing source.

This paper did not discuss the organizational aspects of founding MNTK "PP" and RTs in terms of personnel and material-technical resources. These aspects ought to be studied in detail once this NTP [scientific and technical program] is accepted for implementation. Highly skilled personnel will be needed; TSVT for shared use must have a large memory and a large number of peripheral devices.

To summarize, the creation of MNTK "PP" and RTs for execution of regularly recurrent tasks in creation of new (modernized) technologies and processes and improving existing technology manufactured by the industry and controlling specializing production at industrywide and interindustry levels, as well as at an enterprise, is a long-felt need. Positive resolution of this problem will help change drastically routines in research and development programs and the launch of new industrial products.

Footnotes

1. By an enterprise we mean here design and development organizations involved in the creation of new technologies and processes and industrial enterprises (or associations) that develop, introduce and manufacture new and batch-produced products.
2. Scientific-Technical Products [P] is an application program package containing a standardized information-reference databank on development of new technologies, processes and production management.

UDC025.4:744.43[621+681.2]

**METHODOLOGY OF MAINTAINING A TECHNOLOGICAL CLASSIFIER
OF ENGINEERING AND INSTRUMENT-MAKING COMPONENTS IN
COORDINATION WITH ESKD [UNIFIED SYSTEM OF DESIGN
DOCUMENTATION] CLASSIFIER¹**

18610406B Moscow STANDARTY I KACHESTVO in Russian No 2, Feb 89 pp 78-83

[Article by B.S. Mendrikov, S.L. Taller, S.I. Razevskiy and M.Z. Movshovich, candidates of technical science: "Methodology of Maintaining a Technological Classifier of Engineering and Instrument-Making Components in Coordination with ESKD [Unified System of Design Documentation] Classifier"]

**[Text] Collection and Analysis of Information on Components for Creating
Detail-Specialized Computer-Assisted Production Divisions**

Collection of information on components, primarily those of a general engineering application, should start with the blueprint of the component and process documents with a minimal amount of manual coding, using TKD [Technological Classifier of Components] codes.

It is recommended that the information collected be entered onto form 4 blanks: "Table of Data on Components" [TSD]; the columns of the table are filled in as illustrated by table 3.

To help automate TKD coding, information from blueprints can be entered into the table of data on components in absolute numbers (sizes, materials, etc.). Inside the computer the data will then be compared with classifier codes. In order to do so, all names of classifier groups and their codes in TKD must first be entered into computer memory.

The computer then will immediately produce information in TKD codes without preliminary manual coding of blueprint data.

Modern methods of machining comprise a wide variety of operations and equipment. Computer printouts produced after TSD data processing (form 5)

Код предприятия-разработчика	Классы 71—76	Номера: регистрационный и исполнения	Обозначение детали, существующее в отрасли				Код группы материала	Код степени точности	Число на программу	Наименование заготовительной операции	T _{п.з.} норм-ч	T _{шт.} норм-ч					
			(1)	(2)	(3)	(4)							(5)	(6)	(7)	(8)	(9)
Размеры детали, мм			Квалитет		Параметр шероховатости или отклонения формы	Масса, кг	Код заготовки	Код характеристики термообработки	Размер партии	Модель оборудования	T _{п.з.} норм-ч	T _{шт.} норм-ч					
Наибольший D (B)		Наибольший H	Наружный	Внутренний									(11)	(12)	(13)	(14)	(15)

Form 4.

Key: 1 — Developer enterprise code; 2 — Classes 71–76; 3 — Registration and execution numbers; 4 — Designation of component accepted in the industry; 5 — Material group code; 6 — Precision degree code; 7 — Number per program; 8 — Name of preparatory operation; 9 — T_{pz} norm-hr; 10 — T_{unit} norm-hr; 10a — Component size, mm; 10b — Quality; 11 — Largest D (in); 13 — Largest (out); 14 — Outer; 15 — Inner; 16 — Roughness or shape deviation parameter; 17 — Weight, kg; 18 — Blank code; 19 — Thermal treatment characteristic code; 20 — Lot size; 21 — Equipment model; 22 — T_{pz} norm-hr; 23 — T_{unit} norm-hr.

Table 3.

Number	Name
1	Developer enterprise code
2	Component code in classes 71–76
3	Registration number of the specific characteristic of classes 71–76 assigned conditionally
4	Existing designation of component in the industry
5	Code of material group according to TKD (table 0)
6	Precision code for shape tolerance and surface positioning according to TKD (table 4.5)
7	Annual component output program, units
8	Model of equipment used for preparatory operation (for example, when cutting a piece of rolled stock: model of the cutting machine)
9	Preparatory and finishing time per operation, T_{pz} norm-hr
10	Unit time of operation T_{unit} norm-hr
11 } 12 } 13 }	Size characteristic code according to TKD (tables 0.1–0.2) or absolute component dimensions according to blueprint, mm
14	Quality code according to TKD (table 4) or absolute quality value with the smallest tolerance field of outer and inner surfaces according to blueprint or shape and surface position deviation code
16	Roughness parameter code according to TKD (table 4) or absolute values of smallest roughness element parameter of outer surfaces according to blueprint
17	Component weight code according to TKD (table 4.8) or component weight according to blueprint, kg
18	Blank code according to TKD (table 4.2)
19	Thermal treatment characteristic code according to TKD (table 4.7)
20	Size of the lot of components introduced into production process simultaneously, units
21	Models of industrial equipment employed in all operations of the production process (written as a column list)

Код предприятия-разработчика	Классы 71—76	Номера: регистрационный и исполнения	Обозначение детали, существующее в отрасли			Код размерной характеристики		Автоматы и полуавтоматы токарные	Токарно-револьверные	Токарно-карусельные и лоботокарные	Токарно-центровые	Резьботокарные, резьбо-нарезные и резьбо-фрезерные	Сверлильные	Для обработки глубоких отверстий	Горизонтально и координатно-рас-точные		
																(1)	(2)
Число на программу, шт.	Код материала	Код исходной заготовки	Код			Код		Шлифовальные	Зубо-обра-баты-вающие и шли-цефре-зерные	Шлище-и резь-бошли-фоваль-ные и зубо-отде-лочные	Фре-зерные	Протяж-ные	Агре-гатные	Про-чие	Общая трудо-ем-ность, норм-ч.		
			качества	параметра шероховатости	степень точности	термообра-ботки	массы									(17)	(18)
(14)	(15)	(16)	(17)	(18)	(19)	(20)	(21)	(22)	(23)	(24)	(25)	(26)	(27)	(28)	(29)		

Form 5.

Key: 1 — Developer enterprise code; 2 — Classes 71-76; 3 — Registration and execution numbers; 4 — Designation of component accepted in industry; 5 — Code of size characteristic; 6 — Automatic and semiautomatic lathes; 7 — Turret lathes; 8 — Turret lathes and facing lathes; 9 — Center lathes; 10 — Thread-cutting and thread-milling lathes; 11 — Drills; 12 — For deep holes; 13 — Horizontal and jig-boring machines; 14 — Number per program; 15 — Material code; 16 — Initial blank code; 16a — Code; 17 — Quality; 18 — Roughness parameter; 19 — Precision degree; 20 — Thermal treatment; 21 — Weight; 22 — Grinders; 23 — Gear and slot cutters; 24 — Slot and thread grinders and gear finishers; 25 — Millers; 26 — Broachers; 27 — Transfer machines; 28 — Others; 29 — Total labor input required, hr.

should isolate only the basic machining operations that are typical for components of bodies of revolution and components that do not belong to bodies of revolution and are classified as "other."

In computer printout forms, machine tools are isolated so as to enable an engineering process to be analyzed in terms of the state of the art of the equipment used.

Modern computers are required for processing of this information for the following reasons: a very large volume of information; diverse data dimensions (norm-hours, kilograms, millimeters); the absence of final data in the raw information; and a large number of information processing modalities.

After information is processed by the computer, it is not recommended that information be entered each time from the punched cards because the device for data input from punched cards is of low reliability. Information from a file of punched cards or punched tapes ought to be recorded on magnetic tape so that all subsequent processing would be conducted from that tape.

An analysis of manufacturing of components in terms of existing engineering processes and taking into account the labor costs of the main operations makes it possible to:

- sketch a list of detail-specialized manufacturing divisions (sections, workshops or enterprises) that ought to be created to

satisfy the needs of an enterprise, a production association, an industry or an economic region;

- estimate the state of the art of an engineering process and define the expected percentage measuring the reduction of labor costs;
- taking into account the annual equipment stock with the assumption of two-shift work, estimate approximately (for a working project) the need for equipment that will be required to create component-specialized manufacturing divisions and the production space that will be necessary.

In the computer printout all the components are organized according to increasing class codes 71-76; within a code, according to increasing dimensions (this arrangement of information is not related to its arrangement in TSD). Headings in computer printouts are repeated on each sheet.

An ATsPU [alphanumeric printer] has 188 character positions per line. Any position can accommodate a letter, number or symbol. Positions 7, 14, 20, 34, 44, 54, 65, 74, 84, 94, 104, 114 and 125 are dedicated to vertical separation lines.

The following final figures are in the spreadsheet: composite labor costs of the components:

- those that have the same code in classes 71-76;
- those with the same subgroup code;
- groups;
- belonging to the same subclass;
- forming the first two subclasses or the third, fourth and fifth subclasses, or the sixth and seventh subclasses.

For user convenience, the totals in the spreadsheet are emphasized by underlines or a line space.

Before creating a component-specialized factory, an analysis should be undertaken of the blanks used and a decision should be made whether to build a workshop to make forged or cast blanks, or to arrange to receive them from an outside supplier on a cooperative basis. This analysis includes review of computer printout data on material-intensiveness and labor-intensiveness of blank manufacture (form 6). The information is arranged according to codes of the blank components, material codes and component codes in classes 71-76. Totals of labor-intensiveness are computed for each type of blank. Before that, totals are calculated within each blank code according to material codes and within each material code according to codes of classes 71-76 (subgroups, groups and subclasses).

On the whole, computerized information processing is conducted by a computer program. The program consists of several modules interlinked by a control program. The first to operate is the module writing information from the

(1) Код заготовки	(2) Код материала	Код предприятия-разработчика (3)	(4) Классы 71-76	Номера: регистрационный и исполнения (5)	Обозначение детали, существующее в отрасли (6)	Число на программу, шт. (7)	Код размерной характеристики (8)	Масса, кг (9)		Общая масса заготовки, кг (12)	Общая трудоемкость, нормо-ч. (13)
								детали (10)	заготовки (11)		

Form 6.

Key: 1 — Blank code; 2 — Material code; 3 — Developer enterprise code; 4 — Classes 71-76; 5 — Registration and execution numbers; 6 — Component designation accepted in the industry; 7 — Number per program, units; 8 — Dimension characteristic code; 9 — Weight, kg; 10 — Component; 11 — Blank; 12 — Total weight of blank, kg; 13 — Total labor input, norm-hr.

punched card files onto magnetic tape. This involves not only rerecording but processing for compact and convenient information arrangement and the possibility of modification (eliminating discontinued components, adding new components, changing norms and numbers of the annual plan, etc.).

The following modules will be responsible for generation of various computer printouts.

Basic Methodological Instruction on Component Grouping

Enterprises engaged in individual small-lot and batch production operate with noncontinuous manufacturing processes.

Component-specialized industrial subdivision with group organization make it possible to switch industry to flow-line production and specialize worksites, making them ready to receive for machining any components within the production-technological group.

Component grouping is a major task in the organization of group production. When an enterprise or a production association deals with tens of thousands and sometimes hundreds of thousands of component blueprints, grouping can only be accomplished on a computer.

The classification features embodied in classes 71-76 and the Technological Classifier of Components for Engineering and Instrument Making are insufficient for component grouping. Classification groups of classes 71 and 72 do not provide an exhaustive idea of the degree of complexity of components, because the increasing value of the numeric code of groups of components does not reflect any increasing complexity in their geometric shape.

For this reason it is recommended to introduce for arrangement of these component groups additional features to characterize the number of steps in components simultaneously with regard to the outer surface configuration, the

shape of the central orifice and the existence of annular recesses on endfaces. For each group — taking into account the number of gradations, the existence of threading, additional orifices, grooves, flats and facets — blocks of components are compiled: this is the first stage of grouping.

Grouping components which have the same species code (classes 71-76) and taking account of groups according to the technological process classifier make it possible to put together groups that can be handled by typical or group technological processes. However, Soviet and foreign experiences indicate that these groups are not sufficient for a full equipment loading. For this reason, in order to create component-specialized production associations and organize group production, the first step of grouping should be arranged as assembly of blocks of components made up of combinations of various specific groupings of classes 71-76 and TKD groupings.

Within the blocks classes 71-76 and the serial number of the species are to be given, as introduced according to convenient computer data processing. Classification group codes are then replaced by these numbers in the computer; in the output spreadsheet they are again replaced by classes 71-76.

The grouping is conducted according to the principle "from better to worse but acceptable," i.e., by gradual removal of restrictions as long as the next component added to the group is still technologically compatible with those of the initial species.

The computer carries out the grouping automatically, stage by stage, until obtaining optimal technological groups, that is, until the labor-intensiveness of main operations is at least 70 percent of the monthly load of equipment in terms of main technological operations (turning, milling, boring, etc.).

Computer data processing in preparing production-technological component groups is depicted in flowchart 3. The list of components in the course of computer processing is sorted out as follows:

- a) initially, according to increasing numeric codes of component classification characteristics;
- b) within each group (as per item a) — according to increasing groups of materials;
- c) within each group of materials — according to increasing groups of component size characteristics;
- d) within the group of size characteristics — according to thermal treatment groups;

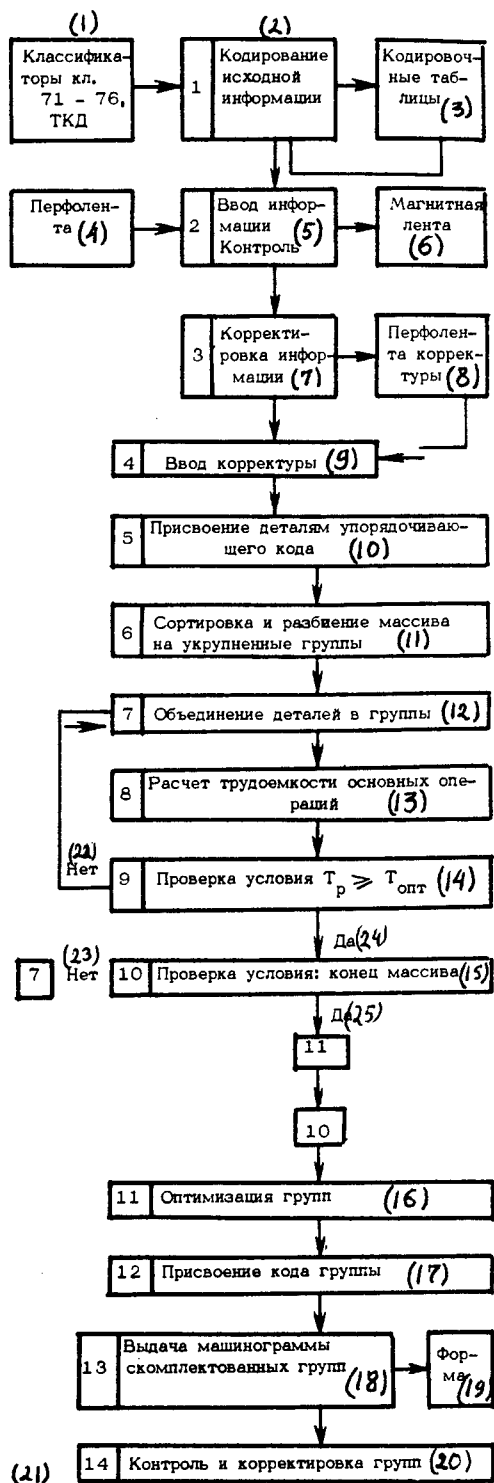

Flowchart 3.

Key: 1 — Classifier classes 71-76, TKD; 2 — Input information copying; 3 — Code tables; 4 — Punch tape; 5 — Information input verification; 6 — Magnetic tape; 7 — Information correction; 8 — Corrected punch tape; 9 — Correction input; 10 — Assignment of ordering code to components; 11 — Sorting file and dividing it into aggregate groups; 12 — Combining components to groups; 13 — Calculating labor costs of main operations; 14 — Testing the condition $T_{calc} > T_{opt}$; 15 — Testing the condition: end of file; 16 — Group optimization; 17 — Group code assignment; 18 — Producing printout of groups as formed; 19 — Format; 20 — Group verification and correction; 21 — $T_{calc} < T_{opt}$ = calculated and optimal labor costs, respectively; 22 — No; 23 — No; 24 — Yes; 25 — Yes.

e) within thermal treatment group — according to steplike property;

f) steplike property group — according to increasing serial block number;

g) components of each block — according to increasing quality factor groups;

h) within quality factor group — according to increasing size characteristics — first increasing diameters and then component length;

i) in each size characteristic group — according to increasing precision degree;

j) finally, within the last group, components are sorted according to increasing serial number of species in the block.

As a result, component groups are obtained that are characterized by maximum similarity in terms of adaptability to streamline production.

Methodological Instructions on Adoption of Engineering Processes

A basic flaw in the existing process-engineering preparation of production is that each process is prepared on an

individual nonsystematic basis. The production process for each component is devised separately each time. In a single-unit small-lot or batch production and with individual design of each engineering process, it is impossible to introduce modern technology and streamlined production.

Development of typical and group manufacturing processes should rely on groups of components similar in terms of design and production processes with the aid of codes of classes 71-76 and the codes of the Technological Classifier of Components for Engineering and Instrument Making. Each enterprise ought to create an information-searching system [IPS] of its own to find previously developed manufacturing processes and group manufacturing operations that are analogous to what is required according to blueprints of newly designed components received by process-engineering departments.

A component-based IPS must rely on codes:

- components of classes 71-76 included in the process;
- operation characteristics of the equipment used in machining of shape-forming surfaces corresponding to the codes of the size characteristic of the largest component in a group (among those that can be processed by the piece of equipment concerned);
- aggregate group of materials taking into account susceptibility to machining;
- group of components according to thermal treatment characteristics.

This information must be transferred to an information-computing center [IVTs] for each new manufacturing process developed. The information is registered on a special form which serves also for registration of typical and group manufacturing processes according to the form shown in table 4.

External computer memory units keep information on manufacturing processes that have been developed (typical or group processes). Flowchart 4 describes computerized information processing.

After receiving a new component (a blueprint) the appropriate information is transmitted to IVTs; after the blueprint is processed by a computer the process engineer receives a computer printout with process specifications.

Guided by the printout, the process engineer receives from the technological archive a pertinent existing manufacturing process. He determines the possibility of adding the new component to this process and the group technological operations that comprise it.

Examples of methods for solution of typical industrial problems are given in an appendix to the Technological Classifier of Components.

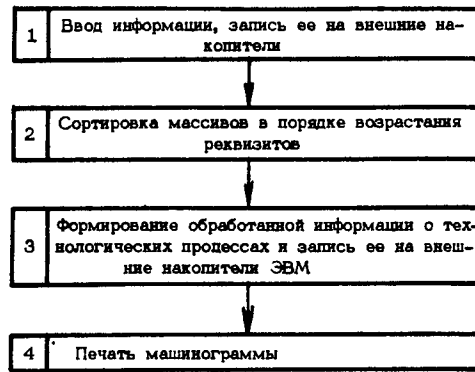

Flowchart 4.

Key: 1—Information input and recording on external media; 2—Sorting files according to increasing number of attributes; 3—Forming final information on engineering processes and recording in external computer memory; 4—Printout.

Table 4.

Designation of technological document	Codes of classes 71-76				Code of size characteristic (largest)	Code of material group	Code of thermal treatment characteristic
	Class	Subclass	Group	Subgroup			
According to ESTD	71	1	1-7	1-9	941	01	1
GOST 3.1201-85		2	1-7	1-9			

A comprehensive introduction of TKD and ESKD Classifier in the nearest future will provide:

- reduction of time and labor cost in development of documentation by a factor of 1.5-2;
- reduction of manufacturing preparation costs by 50 percent;
- increasing the degree of specialization and concentration of production of components by a factor of 2-3.

Footnotes

1. Completion. For the beginning, see STANDARTY I KACHESTVO, No 1, p 25, 1989.

UDC 538.945

Production of High-Temperature Superconducting Materials

18610508 Kiev VISNYK AKADEMIYI NAUK UKRAYINSKOYI RSR in Ukrainian No 12, Dec 88 pp 19-24

[Article by AN UkSSR Corresponding Member V.P. Seminozhenko, Candidate of Technical Sciences M.B. Kosmyna, Candidate of Chemical Sciences L.A. Kotok and Doctor of Physical Mathematical Sciences V.M. Dmitriyev; first paragraph is VISNYK AKADEMIYI NAUK UKRAYINSKOYI RSR introduction]

[Text] The paper deals with methods for production of high-temperature superconducting materials (both ceramic materials and monocrystals).

For successful implementation of high-temperature superconducting (HTSC) materials in electronics, they must possess certain physical, chemical and mechanical properties, the most important being critical temperature T_c , the temperature range of transition to the superconducting state (ΔT_c), maximum current density in this state I_c and magnitudes of critical magnetic fields H_{c1} and H_{c2} .

Properties such as physical, chemical and thermal stability, radiation stability and material density and ductility are also very important.

Ceramic Materials

Solid-phase synthesis is the most widely used method for obtaining HTSC materials. It is characterized by simplicity and high workability.

Source compounds are rare earth element oxides, copper oxide and barium oxide or carbonate. "Extremely pure" reagents are used; if necessary, they are first crushed and then mixed in the stoichiometric ratio, until a homogeneous mixture is obtained. The selection of synthesis parameters is preceded by studying the mechanism of the reaction of formation and decomposition of the superconducting phase.

The use of various analytical methods, such as the differential-thermal analysis (DTA), thermogravimetric analysis, X-ray phase analysis (RPA) (including high-temperature RFA), X-ray fluorescent analysis, chemical analysis, dilatometric analysis, electron microscopy and electron-probe analysis, made it possible to discover the multistage character of processes

that take place, discover the reversibility of the process of formation of the 1-2-3 phase due to the identical character of intermediate compounds Zn_2BaCuO_5 and $BaCuO_2$, which are observed both during the synthesis and decomposition, and determine the domain of existence of the superconducting phase.

We found that the threshold temperature above which decomposition of the 1-2-3 phase begins depends on the radius of the rare earth ion. Thus, for compounds with ytterbium it is equal to $930^\circ C$, for compounds with yttrium it is equal to $975^\circ C$, and for compounds with gadolinium no decomposition is observed until temperature reaches $1,150^\circ C$.

In choosing optimal synthesis parameters, one should take into account, along with results of physico-chemical studies, also the disperse composition and surface condition of source powders.

In order to complete a chemical reaction and form the main phase, the first stage of the synthesis is conducted in powder in the $800-900^\circ C$ temperature range; the second stage is formation and annealing of the compactions.

Ceramics with the highest density is produced by hot compacting. By varying temperature and pressure, it is possible to obtain compactions with the density equal to 95 % of theoretical density. The nature of superconductivity is still unclear, however, it has been found that superconducting properties are highly sensitive to oxygen content. Because of this, tablets as a rule are annealed in oxygen, whose content in a material should not exceed a certain value. A lack or excess of oxygen leads to the loss of superconducting properties. According to our data, the ratio in superconducting specimens of system $ZnBa_2Cu_3O_{7-\delta}$ varies within ≤ 0.4 .

Ceramics synthesized with the help of hot compacting have the following stable parameters: T_c for a system with Y is 96.5K, Tm - 96K, Yb - 94.4K, Gd - 97K, Er - 94K, ΔT_c - 1-2K, I_c in a constant mode at 4.2K is on the order of 20-80 A/cm², and the upper critical magnetic field H_{c2} is 20-25 Tl. The content of the 1-2-3 phase is at least 95 %. One can use ceramics with these characteristics as a target for sputtering HTSC films.

H. Maeda [1] and his colleagues have recently discovered new classes of high-temperature superconductors that do not contain rare earth elements. A superconductor based on a Bi-Sr-Ca-Cu-O system is such a material.

In order to select optimum conditions for producing ceramics in this system, the process of interaction of source components at various ratios of metal ions was studied using derivatography, dilatometry and X-ray phase analysis methods. It had been found that the process takes place in the $770-840^\circ C$ temperature range, regardless of the ratio of Bi, Sr, Ca and Cu ions. The endothermal peak at $890^\circ C$ corresponds to melting of the compound that has formed. Comparison of DTA curves for the source mixture and mixture annealed at $800-820^\circ C$ had demonstrated that the process of formation had been completed.

On DTA curves one can only see the endoeffect of melting at 890°C, while curves for the annealed mixture show relatively insignificant weight loss up to the melting point.

Based on studies of curves showing weight loss for 10-g specimens during heating and cooling, one can draw the following conclusions: losses of oxygen by these compounds are fairly insignificant and reversible; a compound melts incongruently, which is indicated by weight loss after a specimen starts melting (melting is observed in the 890-1,150°C temperature range); expansion-shrinking curves (DTA) confirmed intensive interaction of source components in the 600-860°C temperature range, accompanied by drastic expansion of a specimen before the start of sintering at 860°C.

Comparison of X-ray diffractographs of various specimens demonstrated that in the process of annealing the content of the orthorhombic phase had increased and the number of components that had not reacted had decreased, however, even after the second annealing the product was multiphase. Compound identification was performed using data in [1]. An X-ray phase diffractogram of a 1:1:1:2 compound is in full agreement with its phase diffractogram shown in [1].

The phase diagram of $\text{Bi}_2\text{Sr}_{3-x}\text{Ca}_x\text{Cu}_2\text{O}_y$ compounds corresponds to the phase diffractogram of a 2:2:1:2 compound. [2] describes this structure as a pseudotetragonal or A-centered orthorhombic structure with space group F_{mmm} and parameters $a = 3.59$, $b = 5.4$ and $c = 30.83$.

It should be noted that for compounds we synthesized line intensities are not the same and that we observed a plane reflection line, which was not mentioned by those authors. Based on the data obtained, synthesis conditions had been selected.

Results of studies of the produced specimens had demonstrated that temperature-electric resistance curves are characterized by a linear decrease in electric resistance as temperature decreases from 300 to 120K. Starting at 120K, resistance decreases rapidly as temperature further decreases and becomes equal to zero for various specimens in the 40-90K temperature range. Simultaneous studies of magnetic properties of the specimens showed the appearance of diamagnetism, starting at 120K. The extraction of this phase is the subject of a future technological effort. Because literature [1 and 2] presents data indicating that a phase with a higher T_c is formed at premelting temperatures, we studied T_c^0 dependence on the sintering temperature of $\text{Bi}_2\text{Sr}_{3-x}\text{Ca}_x\text{Cu}_2\text{O}_y$ tablets and demonstrated that as sintering temperature increases, so does T_c^0 . And according to RPA data, in an A-centered orthorhombic structure there is a characteristic reflex with $d = 15.4\text{\AA}$, which has the maximum intensity in a $\text{Bi}_2\text{Sr}_{2.33}\text{Ca}_{0.67}\text{Cu}_2\text{O}_y$ specimen with superconducting transition from 128 to 89K.

Comparing to an 1-2-3 system, this material is more stable and can be produced without oxygen treatment. In addition, the low cost of bismuth ceramics makes its use promising. At the same time it should be stressed that in certain cases we also observed such behavior of electric and magnetic properties in a Y- and Er-based 1-3-3 system, as well as in the case of partial substitution

of fluor for oxygen in this system. In this case, zero resistance was achieved at 100-103K. Apparently, in this system too the extended and often stepwise transition within 100-120K is due to the presence of high-temperature phases, which one has yet to identify.

Monocrystals

Production of high-temperature superconducting monocrystals opens up wide opportunities for studying the mechanism of high-temperature superconductivity and provides a new class of promising materials for modern technology. At present, the most widely used method is growing high-temperature superconducting monocrystals from a solution-melt.

NPO [scientific production association] "Monokristallreaktiv" used exactly this method to manufacture a broad class of monocrystals in systems $\text{R}\text{Ba}_2\text{Cu}_3\text{O}_{7-\delta}$, $\text{R}\text{Ba}_{2-x}\text{Sr}_x\text{Cu}_3\text{O}_{7-\delta}$ (where R is Y, Ho, Nd, Tb or Gd) and $\text{Bi}_2\text{Sr}_{3-x}\text{Cu}_x\text{Cu}_2\text{O}_{8+y}$. Their physical properties were studied in cooperation with the AN UkSSR Low Temperatures Physical Technical Institute.

Crystals were grown in air in trizone resistance furnaces equipped with programmable controllers RIF-101. The specified temperature was maintained accurate to 0.3-0.5°C. Crucibles were mainly made of platinum and in some cases of aluminum oxide.

Crystals of five-component compounds $\text{R}\text{Ba}_{2-x}\text{Sr}_x\text{Cu}_3\text{O}_{7-y}$ (where R is Y, Ho, Nd, Tb and Gd) were produced for the first time. These compounds are of interest, because partial substitution of strontium for barium atoms can significantly change interatomic distances in the crystal cell, particularly lengths of Cu-O bonds that significantly affect electronic properties of a compound. Besides, the introduction of strontium changes structural characteristics of lattices, the most important of which are the degree of deviation from tetragonality and the presence of twinning.

To grow $\text{R}\text{Ba}_2\text{Cu}_3\text{O}_{7-\delta}$ and $\text{R}\text{Ba}_{2-x}\text{Sr}_x\text{Cu}_3\text{O}_{7-\delta}$ monocrystals, one used excess copper and barium compound as a solvent. The crystallization range is 1,350-1,100°C, and the rate of cooling is 5°C/hour.

In solution-melts of multicomponent systems $\text{R}_2\text{O}_3\text{-BaO-SrO-CuO}$ and $\text{R}_2\text{O}_3\text{-BaO-CuO}$, crystallization of several phases takes place, which hinders the production of large size monocrystals when slowly cooling the melt.

The microscopic and X-ray analysis were used to identify crystal phases with various habitus - $\text{R}\text{Ba}_{2-x}\text{Sr}_x\text{Cu}_3\text{O}_7$, CuO and Y_2BaCuO_5 . Well-cut three-dimensional monocrystals $\text{Y}\text{Ba}_{2-x}\text{Sr}_x\text{Cu}_3\text{O}_{7-\delta}$ and $\text{Y}\text{Ba}_2\text{Cu}_3\text{O}_{7-\delta}$ with a tetragonal symmetry and major dimensions 1 x 0.7 and 0.5 mm were mechanically extracted from a solidified melt mass. A methodology of magnetic separation in liquid nitrogen and extraction of superconducting crystalline phases from melt has been developed. Individual $\text{Y}\text{Ba}_{2-x}\text{Sr}_x\text{Cu}_3\text{O}_{7-\delta}$ crystals in the form of rectangular prisms had dimensions 2.5 x 2 x 1 mm, and $\text{Nd}\text{Ba}_{2-x}\text{Cu}_x\text{O}_{7-\delta}$ crystals had 2.5 x 2.5 x 0.5 mm dimensions.

In the case of partial substitution of strontium for barium in system $\text{YBa}_{2-x}\text{Sr}_x\text{Cu}_3\text{O}_{7-\delta}$, it was determined that superconducting orthorhombic monocrystals with $x \approx 0.5-0.8$ were free from the twinning structure typical of pure barium crystals with $x = 0$. It is well known that during the transition from the tetragonal to orthorhombic phase specific twinning that occurs in specimens with barium is manifested in a characteristic splitting of reflexes. When determining lattice parameters with the help of a diffractometer, such splitting complicates the separation of a group of reflexes corresponding to the same orientation. For some of $\text{YBa}_{2-x}\text{Sr}_x\text{Cu}_3\text{O}_{7-\delta}$ crystals that we studied we observed the characteristic splitting of reflexes, which indicates the presence of twins identical to those existing in pure barium specimens. At the same time, we found $\text{YBa}_{2-x}\text{Sr}_x\text{Cu}_3\text{O}_{7-\delta}$ crystals with no splitting typical for twinned crystals. Pumping X-ray patterns do not indicate the presence of twins either. Strontium content in these crystals $x \approx 0.5-0.8$. At higher and lower x , the monocrystals turn out to be twinned. At $x = 0$, monocrystals with parameters $c = 11.723$ (2) Å, $b - a = 0.00812$ Å, $V = 174.98$ (4) Å³, $T_c = 50\text{K}$ and $c = 11.69$ (1) Å, $b - a = 0.044$ Å, $V = 173.2$ (2) Å³ and $T_c = 92\text{K}$ are typical.

In system $\text{YBa}_{2-x}\text{Sr}_x\text{Cu}_3\text{O}_{7-\delta}$ three phases were found - a tetragonal non-superconducting phase, an orthorhombic superconducting phase with low $T_c = 50\text{K}$ and an orthorhombic phase with high $T_c \approx 80\text{K}$. The presence of the three phases is due to differences in the content and distribution of oxygen in cells.

At $x \approx 0.5-0.8$, superconducting $\text{YBa}_{2-x}\text{Sr}_x\text{Cu}_3\text{O}_{7-\delta}$ orthorhombic phase monocrystals do not have a twinned structure, which does not give reason to link high-temperature superconductivity in yttrium systems to the presence of twinning planes in them. A strong (several orders of magnitude) anisotropy of electric resistance along crystallographic axes at room temperature was detected. The resistance is maximum ($\rho \approx 10^{-2}$ Ohm x cm) along direction c . A substantial difference in electric resistance is observed along directions a and b .

In orthorhombic superconducting crystals with twins there is no anisotropy of electric resistance along directions a and b , but there is noticeable anisotropy in directions a , b and c [per original].

Characteristically, high superconducting parameters ($T_c = 84\text{K}$ for $\text{YBa}_{2-x}\text{Sr}_x\text{Cu}_3\text{O}_{7-\delta}$; $I_c(T = 4.2\text{K}) = 5 \times 10^6 \text{A/cm}^2$; residual resistance at $T_c = 4.2\text{K}$ determined from the time change of magnetic moment is under 10^{-23} Ohm/m; $T_c = 94\text{K}$ for $\text{YBa}_2\text{Cu}_3\text{O}_{7-\delta}$; $T_c = 80\text{K}$ for $\text{Ba}_{2-x}\text{Sr}_x\text{Cu}_3\text{O}_{7-\delta}$, and $T_c = 80\text{K}$ for $\text{GdBa}_{2-x}\text{Sr}_x\text{Cu}_3\text{O}_{7-\delta}$) were observed in monocrystals produced in an oxidizing atmosphere without additional heat treatment. In this case, crystals with orthorhombic lattice symmetry were superconducting.

H. Maeda's discovery of new high-temperature superconducting metal oxides with bismuth in early 1988 signified a new stage in the research of HTSC materials. The scientist's results had been rapidly reproduced in a number of laboratories all over the world, including our country. It was found that unlike the Y-Ba-Cu-O system, in Bi-Sr-Ca-Cu-O bismuth compounds high-

temperature superconductivity is maintained when the composition changes in a wide range.

We developed a method for manufacturing $\text{Bi}_2\text{Sr}_{3-x}\text{Ca}_x \cdot \text{Cu}_2\text{O}_8^{+y}$ monocystals from a solution-melt using excess copper compounds as a solvent. The crystallization range is 1,000-800°C and the rate of cooling is 5°C/hour.

Monocrystals were grown in platinum-aluminum oxide crucibles. The process was characterized by appreciable interaction of the Al_2O_3 crucible with the melt, which resulted in intensive contamination of the melt with aluminum impurities. No melt interaction with platinum had been detected. During cooling of solution-melts, a number of phases with various habitus (in the shape of plates, long hexagonal prisms and "needle" crystals) are crystallized in this system.

HTSC lamellar specimens with dimensions up to 6 x 8 x 0.3 mm had a pronounced stratified character. V.S. Melnikov's studies demonstrated that the specimens were characterized by X-ray diffraction reflection with $d = 15.34 \text{ \AA}$. The crystals have an orthorhombic structure with $a = 5.407 \text{ \AA}$, $b = 5.43$ and $c = 30.68 \text{ \AA}$. Electronographic analysis of specimens showed formation of a "superstructure" along direction b ($b = b_0 \times 5 \approx 27 \text{ \AA}$). In electron diffraction patterns one could see the splitting of reflexes that characterizes twinning in these crystals according to two laws - with twin axis $[001]$, $(100)_{\text{I}} // (010)_{\text{II}}$ and with twin plane (110) . Along with the 15.34 \AA HTSC phase, a related orthorhombic phase with $d = 12.29 \text{ \AA}$ was identified. Lattice parameters of this phase were as follows: $a \approx b = 3.87 \text{ \AA}$ and $c = 12.29 \text{ \AA}$. The hexagonal phase was an unknown compound with $a = 4.55 \text{ \AA}$ and $c = 11.31 \text{ \AA}$.

Electric and magnetic studies of monocrystals that we had produced demonstrated the presence of the superconducting transition for various specimens - $T_0 = 57\text{K}$ and $T_0 = 87\text{K}$ for $\rho = 0$. Dependence $\rho(T)$ is characterized by "metallic" behavior until $T = 120\text{K}$, followed by a gradual decrease of ρ and its sharp drop to 0. Annealing of monocrystals at $T = 880^\circ\text{C}$ for 24 hours in air increased the superconducting transition temperature by 6-10K.

Apparently, the fact that a gradual decrease in the electric resistance of studied specimens started at 120K and transition temperatures for various specimens varied from 57 to 87K was due to the presence of solid solutions with complex compositions in system Bi-Sr-Ca-Cu-O.

Polycrystalline Materials

Polycrystals produced from a melt are promising materials for "sputtered targets" for growing film structures and other applications (with high critical currents).

$\text{YBa}_2\text{Cu}_3\text{O}_{7-6}$ dense polycrystalline materials were first created in NPO "Monokristallreaktiv". In specimens with stable properties and increased mechanical strength (compared to ceramics), the maximum density of 6.4 g/cm^3 was obtained. For polycrystals one observed "metallic" behavior of dependence

$\rho(T)$ of specific resistance when temperature changed from 300 to 100K, and the transition itself was fairly narrow ($\Delta T \leq 3$ K at $T_0 = 93.7$ K).

The critical current at helium temperature was as high as approximately 10^3 A/cm². Stable superconducting properties of polycrystal specimens remained for a long time during multiple thermocycling.

In polycrystal specimens of system Bi-Sr-Ca-Cu-O with approximate dimensions 40 x 40 x 2 mm, various types of dependence $\rho(T)$ were observed. In some cases, ρ decreased linearly when temperature decreased from 300 to 120K, then there was a stepwise decrease of ρ followed by a gradual decrease to $\rho = 0$ at $T_0 = 78$ K. Starting at 120K and below, there is diamagnetic response. In other cases, one observed a gradual decrease of ρ starting at $T = 240$ K and a steeper decrease below $T = 120$ K, to $\rho = 0$ at $T_0 = 87$ K, wherein diamagnetic response only appeared at $T = 120$ K and below. This was probably due to the fact that polycrystal specimens contained a phase with $T_c \approx 120$ K. Thus, first ponderable results have already been achieved, and ways for developing an industrial technology for production of new high-temperature superconductive materials have been outlined.

BIBLIOGRAPHY

1. Maeda, H., Tanaka, Y. and Fukutomi, M., JAPAN JOURNAL APPLIED. PHYS. LET., 1988, Vol 27, No 2, pp L203-L211.
2. Subramanian, M.A., Torardi, C.C. and Calabrese, J.C., SCIENCE, 1988, Vol 239, pp 1015-1017.

UDC 629.114.4:621.436-62

GAS DIESEL KamAZ TRUCKS

18610390A Moscow AVTOMOBILNAYA PROMYSHLENNOST in Russian No 1, Jan 89 pp 6-7

[Article "Gas Diesel KamAZ Trucks," published under the rubric "Motor Vehicle Designs"; the first paragraph is an editorial introduction]

[Text] Motor vehicles built by the Kama Auto Factory have long since become a fixture in Soviet automobile transport: more than 1 million units have been built, but the editors continue to receive letters from readers concerning these vehicles, especially after the introduction of gas diesel

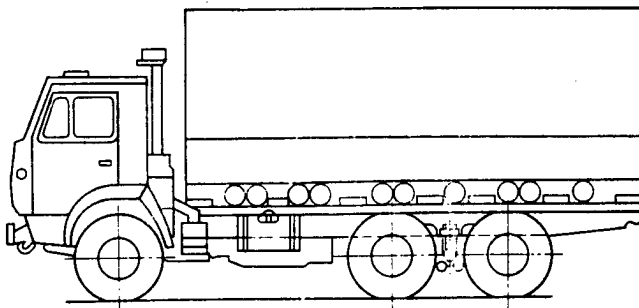

Figure 1.

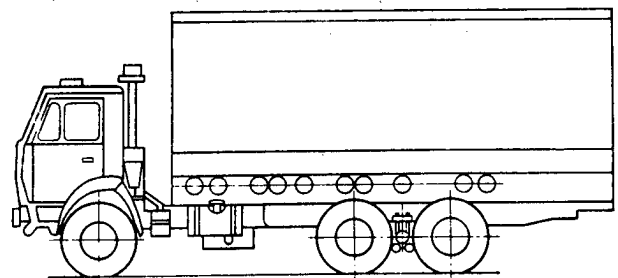

Figure 2.

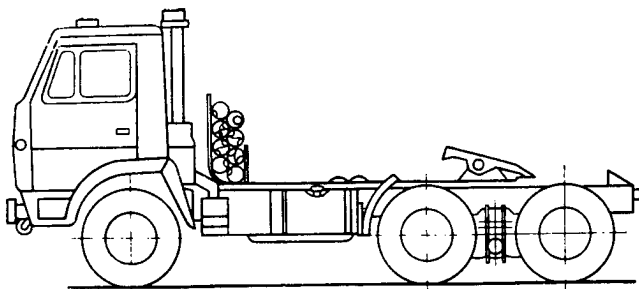

Figure 3.

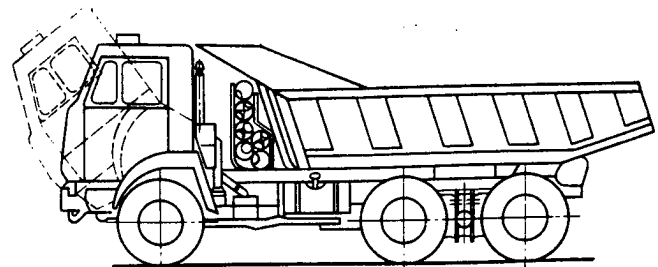

Figure 4.

Table 1.

	KamAZ-53208	KamAZ-53218	KamAZ-53219 KamAZ-53217	KamAZ-54118	KamAZ-55118
Standard consumption in gas diesel cycle at a speed of 60 km/hr (tractor/tractor-trailer):					
diesel fuel, L/100 km	6.5/7	7/8	7/-	-/8	7/-
compressed gas, m ³ /100 km	27/30	30/42	30/-	-/42	30/-
Fuel tank capacity, L	170	170	170	170	170
Gas cylinder capacity at rated gas pressure, L (m ³)	500 (100)	500 (100)	400 (80)	400 (80)	300 (60)
Truck fuel distance endurance at standard fuel consumption, km:					
gas diesel cycle	300	300	300	250	250
diesel cycle	400	4000	4000	400	400
Load carrying capacity, kg	7500	10,000	11,000	—	10,000
Load on saddle-drawbar, kg	—	—	—	11,100	—
Weight, kg:					
unequipped truck	7500	8425	7475	7450	9230
equipped truck	7800	8725	7725	7750	9600
total	15,450	18,875	18,875	19,000	19,750
Weight distribution on axles, kg					
front axle	4500	4500	4500	4500	4500
rear axle	10,950	14,375	14,375	14,500	15,050
Admissible truck weight deviation, %	3	3	3	3	3

Table 2.

Operation mode	Gas-diesel	Diesel
Rated power, kW (hp)	154 (210)	154 (210)
Rated rotation speed, min ⁻¹	2500	2600
Maximum torque, Nm (kg(f)m)	637 (65)	637 (65)
Crankshaft rotation speed at maximum torque, min ⁻¹	1300-1800	1600-1800
Weight, kg	740	740
Minimal per-unit fuel consumption, m ³ /kW hr (g/kW hr):		
by speed characteristic	0.26 + 5%	(224 + 3%)
at rated power	0.28 + 5%	(242 + 3%)
Hourly consumption of ignition dose of diesel fuel at rated power, kg/hr	5-7.5	—

modifications. Most letters inquire about the specifics of design, operation and maintenance of these vehicles. In order to satisfy the interest of our readers, the magazine here begins a series of information materials that have been requested. The first such piece appears below.

Specifications

At the present time, the Kama Association for Heavy Load Truck Production manufactures six gas diesel modifications: two lorry trucks (KamAZ-53208 and KamAZ-53218) (fig. 1); the KamAZ-54118 saddle truck (fig. 2); the KamAZ-55118 dumptruck (fig. 3); and two chassis modifications (KamAZ-53217 and KamAZ-53219) (fig. 4). The specifications for these trucks are given in table 1.

All modifications have KamAZ-7409.10 diesel engines, operating according to the gas diesel cycle. Its characteristics are given in table 2.

- END -

22161

57

NTIS
ATTN: PROCESS 103
5285 PORT ROYAL RD
SPRINGFIELD, VA

22161

This is a U.S. Government publication. Its contents in no way represent the policies, views, or attitudes of the U.S. Government. Users of this publication may cite FBIS or JPRS provided they do so in a manner clearly identifying them as the secondary source.

Foreign Broadcast Information Service (FBIS) and Joint Publications Research Service (JPRS) publications contain political, economic, military, and sociological news, commentary, and other information, as well as scientific and technical data and reports. All information has been obtained from foreign radio and television broadcasts, news agency transmissions, newspapers, books, and periodicals. Items generally are processed from the first or best available source; it should not be inferred that they have been disseminated only in the medium, in the language, or to the area indicated. Items from foreign language sources are translated; those from English-language sources are transcribed, with personal and place names rendered in accordance with FBIS transliteration style.

Headlines, editorial reports, and material enclosed in brackets [] are supplied by FBIS/JPRS. Processing indicators such as [Text] or [Excerpts] in the first line of each item indicate how the information was processed from the original. Unfamiliar names rendered phonetically are enclosed in parentheses. Words or names preceded by a question mark and enclosed in parentheses were not clear from the original source but have been supplied as appropriate to the context. Other unattributed parenthetical notes within the body of an item originate with the source. Times within items are as given by the source. Passages in boldface or italics are as published.

SUBSCRIPTION/PROCUREMENT INFORMATION

The FBIS DAILY REPORT contains current news and information and is published Monday through Friday in eight volumes: China, East Europe, Soviet Union, East Asia, Near East & South Asia, Sub-Saharan Africa, Latin America, and West Europe. Supplements to the DAILY REPORTS may also be available periodically and will be distributed to regular DAILY REPORT subscribers. JPRS publications, which include approximately 50 regional, worldwide, and topical reports, generally contain less time-sensitive information and are published periodically.

Current DAILY REPORTS and JPRS publications are listed in *Government Reports Announcements* issued semimonthly by the National Technical Information Service (NTIS), 5285 Port Royal Road, Springfield, Virginia 22161 and the *Monthly Catalog of U.S. Government Publications* issued by the Superintendent of Documents, U.S. Government Printing Office, Washington, D.C. 20402.

The public may subscribe to either hardcover or microfiche versions of the DAILY REPORTS and JPRS publications through NTIS at the above address or by calling (703) 487-4630. Subscription rates will be

provided by NTIS upon request. Subscriptions are available outside the United States from NTIS or appointed foreign dealers. New subscribers should expect a 30-day delay in receipt of the first issue.

U.S. Government offices may obtain subscriptions to the DAILY REPORTS or JPRS publications (hardcover or microfiche) at no charge through their sponsoring organizations. For additional information or assistance, call FBIS, (202) 338-6735, or write to P.O. Box 2604, Washington, D.C. 20013. Department of Defense consumers are required to submit requests through appropriate command validation channels to DIA, RTS-2C, Washington, D.C. 20301. (Telephone: (202) 373-3771, Autovon: 243-3771.)

Back issues or single copies of the DAILY REPORTS and JPRS publications are not available. Both the DAILY REPORTS and the JPRS publications are on file for public reference at the Library of Congress and at many Federal Depository Libraries. Reference copies may also be seen at many public and university libraries throughout the United States.