

JPRS-UEQ-90-010

5 JULY 1990



**FOREIGN
BROADCAST
INFORMATION
SERVICE**

JPRS Report

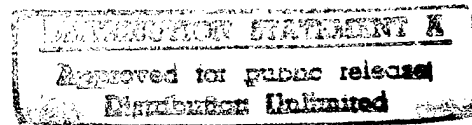

Science & Technology

***USSR: Engineering &
Equipment***

19980121 176

MECHANICS OF GYROSCOPIC SYSTEMS

REPRODUCED BY
U.S. DEPARTMENT OF COMMERCE
NATIONAL TECHNICAL INFORMATION SERVICE
SPRINGFIELD, VA. 22161

DTIC QUALITY INSPECTED 3

SCIENCE & TECHNOLOGY
USSR: ENGINEERING & EQUIPMENT
MECHANICS OF GYROSCOPIC SYSTEMS

907F0290A Kiev MEKHANIKA GIROSKOPICHESKIKH SISTEM in Russian
Issue 8, 1989 (signed to press 5 Jan 89) pp 1-121

[Book edited by M.A. Pavlovskiy, V.N. Koshlyakov, Ye. F.
Chechel'nitskaya et al, Izdatelskoye ob'yediniye "Vyshcha shkola",
500 copies, 121 pages; UDC 531]

CONTENTS

| | |
|--|----|
| Annotation..... | 1 |
| On Dynamics of One-Rotor Gyrocompass With Tuned Rotor Gyroscope [V. V. Avrutov, M. A. Pavlovskiy, et al.]..... | 2 |
| Selecting Geometric Dimensions of Flexible Gimbal Suspension Elements of Tuned Rotor Gyroscopes [I. V. Balabanov, A. N. Motornyy]..... | 11 |
| Study of Dynamics of Two-Degree Gyrotachometer With Rotating Gimbal Suspension [V. S. Yevgenyev, A. V. Yeroshenko, et al.]..... | 18 |
| Dynamic Effects in Gyroscope Based on Flexible Suspension Upon Acceleration of Its Rotor [A. V. Zbrutskiy, L. Yu. Akinfiyeva, et al.]..... | 23 |
| Errors of Angular-Rate Sensor on Tuned Rotor Gyroscope [A. V. Zbrutskiy, S. A. Shakhov]..... | 32 |
| Error of Compensation Pendulous Accelerometer With Flexible Suspension During Operation Under Spatial Vibration Conditions [A. M. Ionin, V. M. Slyusar]..... | 40 |

| | |
|--|-----|
| On Calculation of Temperature Field in Floated Suspension [A. S. Kireyev, A. N. Mikhaylovskaya]..... | 46 |
| Study of Rotation of Solid in Floated Suspension [A. S. Kireyev, Yu. V. Radysh, et al.]..... | 52 |
| Using Redundant Information To Estimate Errors of Measuring Angular Velocity Transducers [A. A. Leonets]..... | 60 |
| Bayes Approach to Problems of Estimating State of Rotary Systems [V. Ye. Petrenko, A. N. Belyakov]..... | 65 |
| Dynamics of Surveyor's Gyrocompass [V. Ye. Petrenko, S. A. Zakharenko, et al.]..... | 72 |
| On Parametric Vibrations of Vibration-Insulated Pendulum [L. M. Ryzhkov]..... | 80 |
| Gyroscopic Effect in Surface Acoustic Waves [S. A. Sarapulov, S. P. Kisilenko]..... | 87 |
| Computer Study of Drift of Cushioned Gyroscope Upon Angular Vibration of Base [S. Ya. Svistunov, Ye. V. Semikina]..... | 93 |
| On Azimuth Motion of Pendulum Gyrocompass During Exponential Acceleration of Its Rotor [V. N. Fedorov]..... | 100 |
| Construction of Discrete Model of Motion of Solid in Flexible Suspension [A. S. Apostlyuk, V. N. Sheludko]..... | 105 |
| Algorithm for Real-Time Calculation of Reduced Moments of Inertia of Multilink Manipulation Systems [S. G. Bublik, V. S. Yevgenyev]..... | 113 |
| Nonlinear Effects in Vibration-Protective Systems With Stiffness Correctors [B. I. Genkin, N. I. Nagulin, et al.]..... | 118 |
| Mathematical Problems of Dynamics of Viscous Liquid in Gyroscopy [G. A. Legeyda]..... | 123 |
| Design of Optimal Follow-Up System With Combination Control [V. V. Lyakin, V. V. Tsisarrzh]..... | 130 |
| Design of Regulator According to Given Characteristic Polynomial for Objects With Permanent Perturbations [Yu. V. Morozov]..... | 136 |

| | |
|---|-----|
| Algorithm for Formulation of Orientation Vector of Moving Object, Invariant to Constant a priori Data Error [M. A. Pavlovskiy, G. Ye. Anupriyenko, et al.]..... | 141 |
| General Solution of Problem of Theory of Elasticity of Rotating Medium [S. A. Sarapulov]..... | 146 |
| Manifold Properties of One Class of Non-Autonomous Systems [N. S. Sivov, M. K. Sparavalo]..... | 151 |
| Optimization of Quantification Period in Digital Follow-Up System With Given Delay [V. M. Slyusar, V. V. Tsisarzh, et al.]..... | 159 |
| Abstracts From Journal MEKHANIKA GIROSKOPICHESKIKH SYSTEM | 163 |

[Text] Annotation

The collection is devoted to study of the dynamic processes in gyroscopic systems, to their use and engineering, to analysis of the errors of gyroscopes, and also to study of control systems.

The book is intended for scientific and engineering and technical personnel, post-graduate students and students, specializing in gyroscopes and control systems.

The editorial board includes: M. A. Pavlovskiy, doctor of technical sciences, professor (editor in chief), V. N. Koshlyakov, corresponding member of the Ukrainian SSR Academy of Sciences (deputy editor-in-chief), Ye. F. Chechel'nitskaya, candidate of physicomathematical sciences, associate professor (secretary), O. F. Boychuk, doctor of physicomathematical sciences, professor, I. Ye. Glazunov, candidate of technical sciences, chief of special design office, O. A. Goroshko, doctor of physicomathematical sciences professor, V. S. Yevgenyev, candidate of technical sciences, associate professor, A. V. Zbrutskiy, doctor of technical sciences, professor, Ya. F. Kayuk, doctor of physicomathematical sciences, professor, V. B. Larin, doctor of physicomathematical sciences, professor, Yu. A. Mitropolskiy, academician of Ukrainian SSR Academy of Sciences, V. Ye. Petrenko, doctor of technical sciences, senior scientific associate, L. M. Ryzhkov, candidate of technical sciences, associate professor, B. D. Samotokin, doctor of technical sciences, professor, P. V. Kharlamov, corresponding member of Ukrainian SSR Academy of Sciences, V. S. Khoroshilov, candidate of technical sciences, chief of special design office, and Ye. S. Shcherbina, candidate of physicomathematical sciences, associate professor.

The address of the editorial board is: 252056 Kiev, prospekt Robedy, 37, Kiev Polytechnical Institute, Department of Theoretical Mechanics, telephone 441-90-42.

UDC 629.12.053.11

ON DYNAMICS OF ONE-ROTOR GYROCOMPASS WITH TUNED ROTOR GYROSCOPE

907F0290B Kiev MEKHANIKA GIROSKOPICHESKIKH SISTEM in Russian, Issue 8, 1989 (manuscript received 21 Oct 89) pp 3-9

[Article by V. V. Avrutov, junior scientific associate, M. A. Pavlovskiy, doctor of technical sciences, and L. M. Ryzhkov, candidate of technical sciences, Kiev Polytechnical Institute]

[Text] Let us study the dynamics of a new type of correctable gyrocompasses--with two-race tuned rotor gyroscope (DNG) as the main sensitive element. The layout of the instrument is shown in the figure. The platform is stabilized with respect to axes Ox and Oz by electromagnetic torque converters (PM) from signals of the DNG angle sensors (IU). The "pendulum" and damping moments are generated by the electromagnetic torque converters of the gyroscope from signals of the accelerometer, whose axis of sensitivity is parallel to axis Oy . Correcting signals, which are generated by the computer of the control circuit from available information on the observer's latitude, the speed of the ship and on the angle of deflection of the platform with respect to axis Oy arrive at the torque converters of the DNG to compensate for the velocity error and the error due to inclination of the platform together with the object with respect to the axis of rotation of the gyroscope. Axis Oy is measured by the accelerometer, whose axis of sensitivity is parallel to the horizontal axis of rotation of the platform.

1. Mathematical model of instrument. The equations of motion of a one-rotor corrected gyrocompass are found by having joined the method of derivation of the equations of the DNG [1], follow-up gimbals [2] and of the control circuit [3].

Let us write the linearized equations of the DNG with regard to the symmetry of the flexible suspension of the DNG in the form

$$\begin{aligned} & (B + b)\ddot{\alpha}_r + (A + 2b)\Omega\dot{\beta}_r + \Delta c\alpha_r + h\dot{\alpha}_r + h\Omega\beta_r + \\ & + [A + 2(a - c)]\Omega\omega_y\alpha_r + (A - B)\dot{\omega}_y\beta_r + (A - 2B)\omega_y\dot{\beta}_r = \\ & = M_z - (B - b)\dot{\omega}_z - (A + a + b - c)\Omega\omega_x - (A + a - B - c)\omega_x\omega_y; \end{aligned} \quad (1)$$

$$\begin{aligned}
& (B + b)\ddot{\beta}_r - (A + 2b)\Omega\dot{\alpha}_r + \Delta c\beta_r + h\dot{\beta}_r - h\Omega\alpha_r + \\
& + [A + 2(a - c)]\Omega\omega_y\beta_r - (A - B)\omega_y\dot{\alpha}_r - (A - 2B)\omega_y\dot{\alpha}_r = \\
& = M_x - (B + b)\dot{\omega}_x + (A + a + b - c)\Omega\omega_z + (A + a - B - c)\omega_y\omega_z,
\end{aligned}$$

where A and a are axial moments of inertia, B , b , and c are equatorial moments of inertia of the rotor and races of the DNG, Ω is the angular rotational velocity of the drive shaft of the DNG, Δc is the residual stiffness of the gimbal suspension of the DNG, h is the viscous damping factor of rotation of the rotor, α_r and β_r are the angles of rotation of the axis of the gyroscope rotor with respect to the body, M_z and M_x are projections of the total control, correction and noise torque, acting from the direction of the body to the gyroscope rotor, onto axes Oz and Ox , and ω_x , ω_y , and ω_z are projections of the angular velocity of the platform onto axes $Oxyz$.

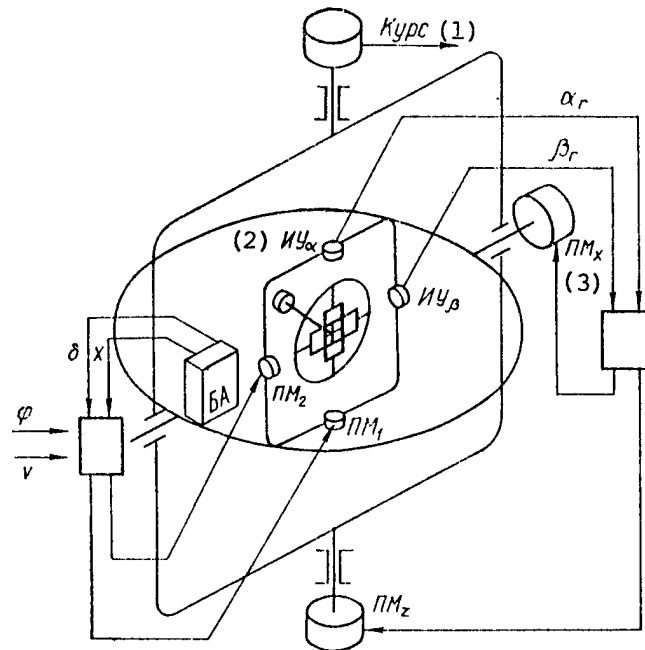

KEY:

- | | |
|----------------|-------------------------|
| 1. Heading | 3. Torque converter |
| 2. Angle meter | 4. Accelerometer module |

Assuming that the kinematics of the platform is similar to that of the follow-up sphere of the corrected gyrocompass with liquid-torsion bar suspension of the sensitive element [3] and taking into account that angle γ is deflection of the platform together with the object with

respect to axis Oy , we write the projections of its angular velocity in the following form:

$$\begin{aligned}\omega_x &= \omega_\xi + \dot{\beta}_c + \omega_\eta \alpha_c - (\dot{\alpha}_c + \omega_\zeta) \gamma, \\ \omega_y &= \omega_\eta - \omega_\xi \alpha_c + (\omega_\zeta + \dot{\alpha}_c) \beta_c + \dot{\gamma}, \\ \omega_z &= \omega_\zeta + \dot{\alpha}_c - \omega_\eta \beta_c + (\dot{\beta}_c + \omega_\xi) \gamma,\end{aligned}\quad (2)$$

where ω_ξ , ω_η , and ω_ζ are projections of the angular velocity of the object onto the axes of geographic coordinate system $O\xi\eta\zeta$ [3] and α_c and β_c are the angles of rotation of the azimuth and horizontal follow-up gimbals.

The equations of motion of the follow-up gimbals are [2]:

$$\begin{aligned}I_z \ddot{\alpha}_c + h_z \dot{\alpha}_c &= M_{\mathfrak{g}_1} + M_\zeta, \\ I_x \dot{\beta}_c + h_x \beta_c &= M_{\mathfrak{g}_2} + M_\xi,\end{aligned}\quad (3)$$

where $I_z = I_\zeta + B + b$; $I_x = I_\xi + B + b$; I_ζ, I_ξ are the moments of inertia of the azimuth and horizontal follow-up gimbals, h_z and h_x are the viscous friction coefficients in the axes of the follow-up gimbals, $M_{\mathfrak{g}_i}$ ($i = 1, 2$) are the electromagnetic moments of the torque converter of the stabilization system, and M_q ($q = \zeta, \xi$) are the torques of the perturbing actions.

The electromagnetic moments are determined by the expressions

$$M_{\mathfrak{g}_1} = W_{k_1}(p) \alpha_r, \quad M_{\mathfrak{g}_2} = W_{k_2}(p) \beta_r, \quad (4)$$

where $W_{h_i}(p)$ ($i=1, 2$) are the transfer functions of the relief circuit regulators.

The laws of position control of the sensitive element of the gyrocompass are taken according to [3]:

$$M_z = -n_z \delta + M_z^k + M_z^u; \quad M_x = -n_x \delta + M_x^k + M_x^u, \quad (5)$$

where δ is the output signal of the horizon indicator, n_x and n_z are the scaling coefficients, M_{q}^{k} are correction moments, and M_{q}^{Π} ($q = z, x$) are the perturbing moments that cause drift of the gyroscope.

Let the output signals of the accelerometer module (BA) be described by the following relations:

$$\delta = \frac{1}{T_y p + 1} \left(\beta_c + \frac{W_{\eta}}{g} \right), \quad \chi = \frac{1}{T_x p + 1} \left(\frac{W_{\xi}}{g} - \gamma \right), \quad (6)$$

where δ and χ are the signals of the north and east horizon indicators, respectively, T_x and T_y are the time constants, and W_{ξ} and W_{η} are the east and north components of acceleration of the object.

Equations (1)-(6) are the input mathematical model of a one-rotor corrected gyrocompass with DNG.

It has become traditional to use the precession model of the device when studying the dynamics and accuracy of corrected gyrocompasses. However, this approach, when the DNG is the sensitive element of the gyrocompass, limits the study of the dynamic features of the device. Let us construct an "integrated" model of a gyrocompass, which takes into account the dynamics of the sensitive element and of the follow-up gimbals, from which the compass and vibration models of the device, respectively, can be found as special cases of analysis of low- and high-frequency vibrations of the object.

The absolute angles of rotation of the sensitive element with respect to the geographic system of coordinates are expressed in the first approximation by the following relations:

$$\alpha = \alpha_c + \alpha_r; \quad \beta = \beta_c + \beta_r. \quad (7)$$

Separating the relative angles of rotation of the gyroscope α_r and β_r from the last expressions, let us substitute them into the equations of motion of the follow-up gimbals (4) and (3). Then

$$\alpha_c(p) = \Phi_{\alpha_c}(p)\alpha + \Phi_{\xi}(p)M_{\xi}, \quad \beta_c(p) = \Phi_{\beta_c}(p)\beta + \Phi_{\xi}(p)M_{\xi}; \quad (8)$$

$$\alpha_r(p) = \Phi_{\alpha_r}(p)\alpha - \Phi_{\xi}(p)M_{\xi}, \quad \beta_r(p) = \Phi_{\beta_r}(p)\beta - \Phi_{\xi}(p)M_{\xi}, \quad (9)$$

where

$$\Phi_{\alpha_c}(p) = W_{k_1}(p) [I_2 p^2 + h_2 p + W_{k_1}(p)]^{-1}, \quad (10)$$

$$\Phi_{\beta_c}(p) = W_{k_2}(p) [I_3 p^2 + h_3 p + W_{k_2}(p)]^{-1};$$

$$\Phi_{\alpha_r}(p) = 1 - \Phi_{\alpha_c}(p), \quad \Phi_{\beta_r}(p) = 1 - \Phi_{\beta_c}(p); \quad (11)$$

$$\Phi_{\xi}(p) = [I_2 p^2 + h_2 p + W_{k_1}(p)]^{-1}, \quad \Phi_{\xi}(p) = [I_3 p^2 + h_3 p + W_{k_2}(p)]^{-1}. \quad (12)$$

Let us write the initial equations of the sensitive element (1) in Laplace transforms at zero initial conditions with regard to (9):

$$\begin{aligned} (Is^2 + hs + \Delta c)(\Phi_{\alpha_r} \alpha - \Phi_{\xi} M_{\xi}) + (Hs + h\Omega)(\Phi_{\beta_r} \beta - \Phi_{\xi} M_{\xi}) &= \\ &= M_x - Is\omega_z - H^* \omega_x, \\ (Is^2 + hs + \Delta c)(\Phi_{\beta_r} \beta - \Phi_{\xi} M_{\xi}) - (Hs + h\Omega)(\Phi_{\alpha_r} \alpha - \Phi_{\xi} M_{\xi}) &= \\ &= M_x - Is\omega_x + H^* \omega_z, \end{aligned} \quad (13)$$

where $I = B + b$; $H = (A + 2b)\Omega$; $H^* = (A + a + b - c)\Omega$; $s = j\omega$.

The equations of motion (13) are the "integrated" mathematical model of a gyrocompass for a wide frequency spectrum.

It is known that the error of reproducing the amplitude in the bandwidth of a closed system does not exceed the permissible value, while the amplitude-frequency characteristic decreases with a further increase of frequency. The following relations are valid for these frequency bands:

1) $0 < \omega < \omega_{\Pi}$ -- bandwidth:

$$\begin{aligned} \Phi_{\alpha_c}(\omega) \approx 1 \Rightarrow \Phi_{\alpha_r}(\omega) \rightarrow 0, \quad \Phi_{\xi}(\omega) \approx K_1^{-1}, \\ \Phi_{\beta_c}(\omega) \approx 1 \Rightarrow \Phi_{\beta_r}(\omega) \rightarrow 0, \quad \Phi_{\xi}(\omega) \approx K_2^{-1}; \end{aligned} \quad (14)$$

2) $\omega \gg \omega_{\Pi}$ -- outside bandwidth:

$$\begin{aligned} \Phi_{\alpha_c}(\omega) \rightarrow 0 \Rightarrow \Phi_{\alpha_r}(\omega) \approx 1, \quad \Phi_{\xi}(\omega) \rightarrow 0, \\ \Phi_{\beta_c}(\omega) \rightarrow 0 \Rightarrow \Phi_{\beta_r}(\omega) \approx 1, \quad \Phi_{\xi}(\omega) \rightarrow 0, \end{aligned} \quad (15)$$

where K_i ($i = 1, 2$) are the total amplification factors of the static-type relief circuit regulators.

Using relations (14) and (15) and omitting the intermediate transformations, let us write equations (13) for two frequency bands. The equations of a gyrocompass in the bandwidth of a closed system assume the following form in temporary form

$$\begin{aligned} H^* (\dot{\beta} + \omega_{\xi} + \omega_{\eta}\alpha - \dot{\alpha}\gamma - \omega_{\xi}\gamma) &= M_z + K_1^{-1} (\Delta c M_{\xi}^B + h\Omega M_{\xi}^B), \\ -H^* (\dot{\alpha} + \omega_{\xi} - \omega_{\eta}\beta + \dot{\beta}\gamma + \omega_{\xi}\gamma) &= M_x + K_2^{-1} (\Delta c \dot{M}_{\xi}^B - h\Omega M_{\xi}^B). \end{aligned} \quad (16)$$

For vibrations at frequencies that do not exceed the bandwidth of a closed stabilization system, equations (13) are transformed to the following system of differential equations:

$$\begin{aligned} I\ddot{\alpha} + h\dot{\alpha} + \Delta c\alpha + H\dot{\beta} + h\Omega\beta &= M_z^B - I\dot{u}_z - H^*u_x, \\ I\ddot{\beta} + h\dot{\beta} + \Delta c\beta - H\dot{\alpha} - h\Omega\alpha &= M_x^B - I\dot{u}_x + H^*u_z. \end{aligned} \quad (17)$$

Here u_x and u_z are the vibration components of the angular velocities of the platform ω_x and ω_z and M_x^B and M_z^B are the high-frequency components of the perturbation moments.

Let us call the motion of the sensitive element with frequencies belonging to the bandwidth of the closed system compass motion, and let us call those outside the bandwidth vibration motion. The follow-up gimbals track the position of the sensitive element with accuracy up to static errors in the case of compass motion. The follow-up gimbals, due to inertia, are unable to counter rapidly variable vibrations of the sensitive element in the case of vibration motion.

Separation of the "integrated" model of motion of the device into compass (16) and vibration (17) permits one to determine the dynamic characteristics of a corrected gyrocompass with DNG.

2. Analysis of compass motion. The compass model of the device (16) assumes the following form with regard to the equations of moments (5)

$$\begin{aligned} H^* (\dot{\beta} + \omega_{\xi} + \omega_{\eta}\alpha - \dot{\alpha}\gamma - \omega_{\xi}\gamma) &= -n_z\delta + M_z^K + M_z^U + \\ &+ K_1^{-1} (\Delta c M_{\xi}^B + h\Omega M_{\xi}^B), \\ -H^* (\dot{\alpha} + \omega_{\xi} - \omega_{\eta}\beta + \dot{\beta}\gamma + \omega_{\xi}\gamma) &= -n_x\delta + M_x^K + M_x^U + \\ &+ K_2^{-1} (\Delta c M_{\xi}^B - h\Omega M_{\xi}^B). \end{aligned}$$

Based on conditions of providing the position of dynamic equilibrium in the direction of the true meridian and in the plane of the horizon, we find ideal values of the correction moments

$$M_z^{kn} = H^* (\omega_\xi - \dot{\alpha}\gamma - \omega_\xi\gamma) - M_z^u - K_1^{-1} (\Delta c M_\xi + h\Omega M_\xi), \quad (18)$$

$$M_x^{kn} = -H^* (\omega_\xi + \dot{\beta}\gamma + \omega_\xi\gamma) - M_x^u - K_2^{-1} (\Delta c M_\xi - h\Omega M_\xi).$$

The following correction moments are realized in practice in a gyrocompass:

$$M_z^k = H (\omega_\xi + n_x \delta\chi) - M_z^u + \Delta M_z, \quad (19)$$

$$M_x^k = -H\omega_\xi - M_x^u + \Delta M_x,$$

where ΔM_x and ΔM_z are the errors of the correcting moments due to errors of measuring the latitude and velocity of the object.

The imperfection of the correction moments results in a methodical error of the gyrocompass:

$$\alpha_0 = U^{-1} \sec \varphi \left[-\omega_l - m\omega_A + \frac{\Delta c}{H^*} (\delta_{\alpha_c} - m\delta_{\beta_c}) + T_r^{-1} (\delta_{\beta_c} - m\delta_{\alpha_c}) \right], \quad (20)$$

where U is the Earth's angular rotation velocity, φ is the observer's latitude, $\omega_A = M_x^u/H^*$, $\omega_l = -M_z^u/H^*$ are the azimuth and horizontal drift of the gyroscope, $\delta_{\alpha_c} = M_\xi K_1^{-1}$, $\delta_{\beta_c} = M_\xi K_2^{-1}$ are the static errors of the follow-up gimbals, $T_r = H^* (h\Omega)^{-1}$ is the time constant of the gyroscope, and $m = n_z/n_x$.

Let us calculate as an example the error component of the gyrocompass (20), caused by the time constant of the DNG and by the static errors of the stabilization system. Let us assume that $T_r = 50$ s and $\delta_{\alpha_c} = \delta_{\beta_c} = 0,1'$; $m = 0,05$; $V \cos \varphi = 7 \cdot 10^{-5}$ s⁻¹. We find in this case that $\alpha_0 = 28.6'$.

Accordingly, disregarding such features as the time constant of the DNG and residual stiffness results in significant errors of the device. Therefore, it is recommended that the last terms from (18) be taken into account in the expressions of the correcting moments (19).

3. Oscillating deviation of gyrocompass. Let us use the compass model of the device (16), having first discarded terms that contain static errors of the follow-up systems for simplification of computations. Let there be rolling motion $\theta = \theta_m \sin(\omega t + \varepsilon)$. The pendulosity of attachment of the center of gravity of the device l causes rotational acceleration, projections of which onto axes $O\xi$ and $O\eta$ are: $W_\xi = \ddot{\theta} l \cos K$; $W_\eta = -\ddot{\theta} l \sin K$, where K is the heading of the object.

Omitting the intermediate transformations, we find the formula of the intercardinal deviation of the gyrocompass

$$\begin{aligned}
 \langle \alpha \rangle = & n_x l \theta_m^2 \omega^4 \sin 2K \left[T_x \cos(\varepsilon_2 - \varepsilon_1) - \frac{l}{g} \omega \cos(\varepsilon_3 - \varepsilon_1) \right] \times \\
 & \times \left\{ 4n_z g U \cos \varphi \left| \frac{1 + \omega^2 T_x^2}{(1 - T_y T_z \omega^2)^2 + \omega^2 T_z^2} \right|^{-1} \right. \\
 & \text{где } \varepsilon_1 = \text{arctg} \frac{1 - T_y T_z \omega^2}{\omega T_x}; \quad \varepsilon_2 = \text{arctg} \frac{1}{\omega T_x}; \\
 & \left. \varepsilon_3 = \text{arctg}(-\omega T_x); \quad T_z = \frac{H^*}{n_z} \right\}. \quad (21)
 \end{aligned}$$

The differences of deviation (21) from the known deviation [4] are manifested due to the structural features of the platform suspension: a two-axis suspension required introduction of algorithmic compensation of the gyrocompass errors, caused by heeling inclinations of the object. However, the constant value of perturbation $\langle \delta(\chi + \gamma) \rangle$, as a result of calculation of which formula (21) is found, is manifested due to the inertia of the accelerometer--of the indicator of given inclinations.

Thus, the frequency method of separation of motion permitted us to find the compass and vibration mathematical models of a corrected gyrocompass, convenient for analysis and which reflect the specifics of application of a DNG as the sensitive element. Disregard of the time constant and of the residual stiffness of the DNG in the case of static regulators of follow-up systems results in considerable errors in determination of meridian, which should be taken into account when working out algorithms for the control and correction circuit.

Study of rolling deviations of the device showed that algorithmic correction of the error of the gyrocompass due to rolling inclinations of the object and due to a two-axis layout of platform suspension does not correct the intercardinal deviation due to the inertia of the accelerometer-indicator of the given inclinations.

BIBLIOGRAPHY

1. Pavlovskiy, M. A. and A. V. Zbrutskiy, "Dinamika rotornykh vibratsionnykh giroskopov" [The Dynamics of Rotary Vibratory Gyroscopes], Kiev, 1984.
2. Aleksandrov, A. D., "Indikatornyye girostabilizirovannyye platformy" [Indicating Gyro-Stabilized Platforms], Moscow, 1979.
3. Koshlyakov, V. N., "Teoriya girokompicheskikh kompasov" [The Theory of Gyrocompasses], Moscow, 1972.
4. Shulman, I. Sh., "Intercardinal Deviation of a Gyrocompass With Liquid-Torsion Bar Suspension," IZVESTIYA AKADEMII NAUK SSSR. MEKHANIKA TVERDOGO TELA, No 4, 1968.

UDC 531.383

SELECTING GEOMETRIC DIMENSIONS OF FLEXIBLE GIMBAL SUSPENSION ELEMENTS OF TUNED ROTOR GYROSCOPES

907F0290C Kiev MEKHANIKA GIROSKOPICHESKIKH SISTEM in Russian, Issue 8, 1989 (manuscript received 15 Oct 87) pp 10-13

[Article by I. V. Balabanov, candidate of technical sciences, and A. N. Motornyy, junior scientific associate, Kiev Polytechnical Institute]

[Text] The purpose of this article is to develop a method of determining the geometric dimensions of flexible elements (Figure 1) of tuned rotor gyroscopes (DNG) upon fulfillment of the following relations:

- 1) the condition of strength upon exposure to impact loads

$$[\tau] \geq \tau_i = \frac{p}{A_i B_i}, \quad (1)$$

where $[\tau]$ is the permissible tangential stress, p is the permissible impact load per flexible element, and A_i and B_i are the geometric dimensions of the flexible element (Figure 1) of variable ($i = 1$) and constant cross-section ($i = 2$);

- 2) the condition of strength upon exposure to cyclic loading

$$[\sigma] \geq \sigma_i = \frac{c_y}{W} \varphi, \quad (2)$$

where $[\sigma]$ is the fatigue strength, φ is the permissible angle of rotation of the flexible element, c_y is the given angular stiffness coefficient of the flexible element with respect to the working axis, W is the moment of cross-sectional resistance of the flexible element, and

$$W = \frac{A_i^2 B_i}{6}; \quad (3)$$

3) the condition of conservation of the angular stiffness factor in a specific range is

$$c_{y\min} \leq c_y \leq c_{y\max}.$$

Let us consider a flexible element of variable cross-section. For this element,

$$c_y = \frac{2E}{9\pi} A_1^{5/2} B_1 R^{-1/2} \quad (4)$$

or

$$B_1 = \frac{9\pi c_y}{2E} A_1^{-5/2} R^{1/2}, \quad (5)$$

where E is Young's modulus.

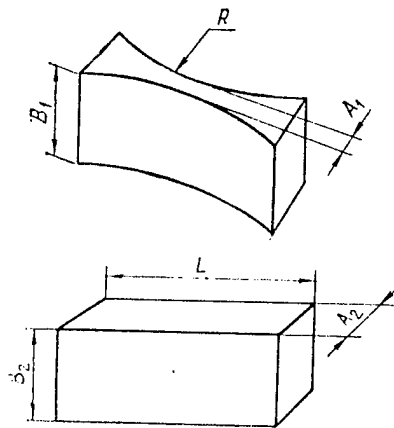

Figure 1

Substituting (3) and (4) into (2), we find condition 2 in the form

$$[\sigma] \geq \frac{4E}{3\pi} A_1^{1/2} R^{-1/2} \varphi. \quad (6)$$

If $B_1 = B_{01}$, let us derive from (1), (5), and (6) the expressions that give the range of selection of dimensions A_1 and R with regard to constraints on the geometric dimensions of the flexible element:

$$R \geq K_{11} A_1 \quad (\text{condition 2}), \quad (7)$$

$$K_{11} = \frac{16E^2 \varphi^2}{9\pi^2 [\sigma]^2};$$

$$R \geq K_{12} A_1^3 \quad (\text{condition 1}), \quad (8)$$

$$K_{12} = \frac{4E^2 p^2}{81\pi^2 c_{y\min}^2 [\tau]^2};$$

$$K_{14} A_1^5 \leq R \leq K_{15} A_1^5 \quad (\text{condition 3}),$$

$$K_{14} = \frac{4E^2 B_{01}^2}{81\pi^2 c_{y\max}^2}, \quad (9)$$

$$K_{15} = \frac{4E^2 B_{01}^2}{81\pi^2 c_{y\min}^2},$$

$$A_1 \leq A_{01} \quad (\text{constraint on dimension } A_1); \quad (10)$$

$$R \leq R_0 \quad (\text{constraint on dimension } R). \quad (11)$$

Let us consider a flexible element of constant cross-section. For this element,

$$c_y = \frac{E}{12L} A_2^3 B_2 \quad (12)$$

or

$$B_2 = \frac{12c_y A_2^{-3} L}{E} \quad (13)$$

Substituting (3) and (12) into (2), we find condition 2 in the form

$$[\sigma] \geq \frac{E}{2} A_2 L^{-1} \varphi. \quad (14)$$

If $B_2 = B_{02}$, let us derive from (1), (13), and (14) the expressions that give the range of selection of dimensions A_2 and L with regard to constraints on the geometric dimensions of the flexible element:

$$L \geq K_{21} A_2 \quad (\text{condition 2}), \quad (15)$$

$$K_{21} = \frac{E\varphi}{2[\sigma]};$$

$$L \geq K_{22} A_2^2 \quad (\text{condition 1}), \quad (16)$$

$$K_{22} = \frac{EP}{12c_{ymin}[\tau]};$$

$$K_{24} A_2^3 \leq L \leq K_{25} A_2^3 \quad (\text{condition 3}), \quad (17)$$

$$K_{24} = \frac{EB_{02}}{12c_{ymax}}, \quad K_{25} = \frac{EB_{03}}{12c_{ymin}};$$

$$A_2 \leq A_{02} \quad (\text{constraint on dimension } A_2); \quad (18)$$

$$L \leq L_0 \quad (\text{constraint on dimension } L). \quad (19)$$

To find the specific values of the dimensions from the above regions, let us introduce coefficients $K_{0i} = \frac{\sigma_{imin}}{\tau_{imin}}$ ($i = 1, 2$), that take into account the different structural and technological constraints on the values of the desired dimensions and that correspond to flexible elements with variable ($i = 1$) and constant ($i = 2$) cross-section.

Let us write with regard to $B_1 = B_{01}$ and $B_2 = B_{02}$

$$K_{01} = \frac{4E\varphi B_{01}}{3\pi p} A_1^{3/2} R^{-1/2},$$

$$K_{02} = \frac{E\varphi B_{02}}{2p} A_2^2 L^{-1},$$

hence,

$$A_1^{3/2} R^{-1/2} = \frac{3\pi\rho}{4E\varphi B_{01}} K_{01} = l_{01}; \quad (20)$$

$$A_2^2 L^{-1} = \frac{2P}{E\varphi B_{02}} K_{02} = l_{02}. \quad (21)$$

It is easy to show that

$$(\sigma_1^2 \tau_1)_{\min} = \sigma_{1\min}^2 \tau_{1\min} = \frac{16 E^2 P \varphi^2}{9\pi^2} B_{01}^{-1} R^{-1}; \quad (22)$$

$$(\sigma_2 \tau_2)_{\min} = \sigma_{2\min} \tau_{2\min} = \frac{E\varphi P}{2} B_{02}^{-1} L^{-1}. \quad (23)$$

It follows from (22) and (23) that

$$R = R_0; \quad (24)$$

$$L = L_0. \quad (25)$$

Substituting (24) and (25) into (20) and (21) and making the necessary transformations, we find

$$A_1 = l_{01}^{2/3} R_0^{1/3}; \quad (26)$$

$$A_2 = l_{02}^{1/2} L_0^{1/2}. \quad (27)$$

When selecting the values of coefficients K_{01} and K_{02} , one must take into account that

$$\frac{4E\varphi B_{01}}{3\pi\rho} R_0^{-1/2} A_{1\min}^{3/2} \leq K_{01} \leq \frac{4E\varphi B_{01}}{3\pi\rho} R_0^{-1/2} A_{1\max}^{3/2}; \quad (28)$$

$$\frac{E\varphi B_{02}}{2p} L_0^{-1} A_{2\min}^2 \leq K_{02} \leq \frac{E\varphi B_{02}}{2p} L_0^{-1} A_{2\max}^2. \quad (29)$$

The method of selecting the geometric dimensions of the flexible elements of variable cross-section is based on relations (7)-(11), (24), (26), and (28), while the method of selecting flexible elements of constant cross-section is based on relations (15)-(19), (25), (27), and (29).

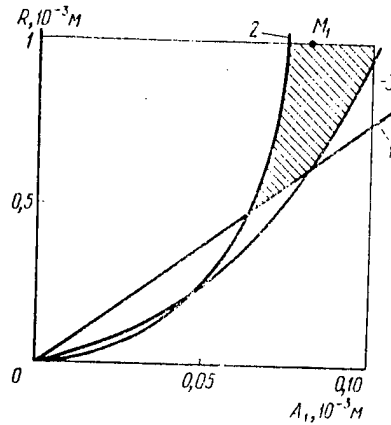

Figure 2

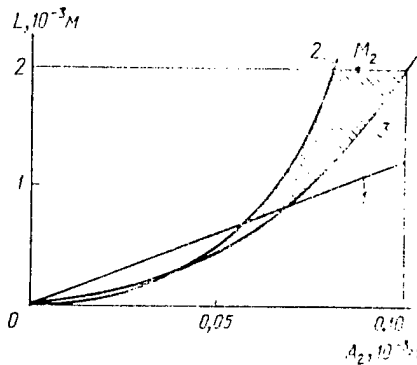

Figure 3

To illustrate the foregoing method, let us consider a numerical example. Let $E = 2 \cdot 10^{11}$ N/m², $p = 9.8$ N, $\varphi = 1.74 \cdot 10^{-2}$ rad, $[\tau] = 46.3 \cdot 10^7$ N/m², $[\sigma] = 72.5 \cdot 10^7$ N/m², $c_{y\min} = 0.8 \cdot 10^{-2}$ N·m, $c_{y\max} = 10^{-2}$ N·m, $B_{01} = B_{02} = 2 \cdot 10^{-3}$ m, $A_{01} = A_{02} = 10^{-4}$ m, $L_0 = 2 \cdot 10^{-3}$ m, $R_0 = 10^{-3}$ m, $K_{01} = 10$, and $K_{02} = 0.5$.

As a result of the calculation, we find $K_{11} = 4.2$, $K_{12} = 1.47 \cdot 10^3 \text{ m}^{-2}$, $K_{13} = 0.94 \cdot 10^3 \text{ m}^{-2}$, $K_{14} = 0.08 \cdot 10^{20} \text{ m}^{-4}$, $K_{15} = 0.13 \cdot 10^{20} \text{ m}^{-4}$, $K_{21} = 2.4$, $K_{22} = 45 \cdot 10^3 \text{ m}^{-1}$, $K_{23} = 36 \cdot 10^3 \text{ m}^{-1}$, $K_{24} = 3.34 \cdot 10^9 \text{ m}^{-2}$, and $K_{25} = 4.17 \times 10^9 \text{ m}^{-2}$.

Let us use the derived values to construct regions for selection of dimensions A_1, R (Figure 2) and A_2, L (Figure 3). These regions are shaded. Curve 1 in Figure 2 corresponds to the expression $R = K_{11}A_1$, curve 2 corresponds to $R = K_{14}A_1^5$, curve 3 corresponds to $R = K_{15}A_1^5$, while curve 1 in Figure 3 corresponds to $L = K_{21}A_2$, curve 2 corresponds to $L = K_{24}A_2^3$, and curve 3 corresponds to $L = K_{25}A_2^3$. We find in the regions for selection of the dimensions points $M_1 (0.023; 1)$ (Figure 2) and $M_2 (0.034; 2)$ (Figure 3), whose coordinates are dimensions A_1, R and A_2, L , respectively.

The studies permit the following conclusions: if the overall dimensions of tuned rotor gyroscopes are identical ($A_1 = A_2$, $B_1 = B_2$, and $2R_0 = L$) and if the strength and stiffness conditions are fulfilled, the angular stiffness factor of the flexible element is less at constant cross-section than it is at variable cross-section. It follows from this that the accuracy of a tuned rotor gyroscope with flexible elements of constant cross-section is higher.

UDC 531.383

STUDY OF DYNAMICS OF TWO-DEGREE GYROTACHOMETER WITH ROTATING GIMBAL SUSPENSION

907F0290D Kiev MEKHANIKA GIROSKOPICHESKIKH SISTEM in Russian, Issue 8, 1989 (manuscript received 4 Oct 87) pp 14-17

[Article by V. S. Yevgenyev, candidate of technical sciences, A. V. Yeroshenko, student, Kiev Polytechnical Institute, and S. G. Bublik, engineer, Kiev Institute of Automation]

[Text] The method of induced rotation of the gimbal suspension of a gyroscope about the vector of the moment of momentum [1] is used for autocompensation of the instrument errors of free gyroscopes. The purpose of this article is study of the possibility of applying this method to two-degree gyrotachometers (GT).

Let us link the orthogonal coordinate system $\{\eta\zeta\}$, axes η and ζ of which are directed in the initial position of the gyrotachometer along the precession axis and the principal axis of the gyroscope, respectively (Figure 1). Let us link system xyz to the movable part of the gyrotachometer such that axes y and z will coincide with the suspension axis of the gyroassembly and the principal axis of the gyroscope, respectively. The body of the gyrotachometer rotates uniformly at angular velocity ω about axis ζ with respect to coordinate system $\{\eta\zeta\}$ (Figure 2) and $\alpha = \Omega t$. Let us assume for analysis of the dynamics of this gyrotachometer that the base rotates about axis η at constant angular velocity ω .

The linearized differential equation of motion of the gyrotachometer has the following form with the respect to the precession axis

$$\begin{aligned} I_y \ddot{\beta} + f \dot{\beta} + [(I_z - I_x)(\Omega^2 - \omega^2 \sin^2 \Omega t) + H\Omega + c] \beta = \\ = H\omega \sin \Omega t + (I_z + I_y - I_x) \Omega \omega \sin \Omega t. \end{aligned} \quad (1)$$

Here I_x , I_y , and I_z are the moments of inertia of the movable part of the gyrotachometer with respect to axes x , y , and z , $H = IP_z \dot{\gamma}$ is the moment of momentum of the gyroscope, IP_z is the axial moment of inertia

of the gyroscope rotor, $\dot{\gamma}$ is the angular rotational velocity of the gyroscope rotor ($\dot{\gamma} \gg \omega$), f is the damping factor, c is the angular stiffness of the flexible element of the gyrotachometer, and β is the angle of rotation of the gyroassembly about the precession axis y .

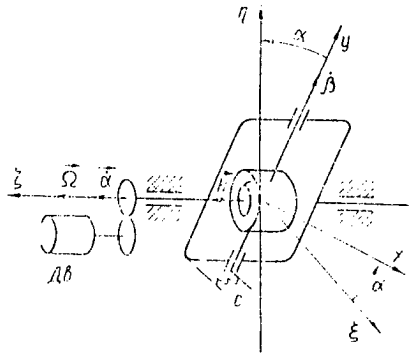

Figure 1

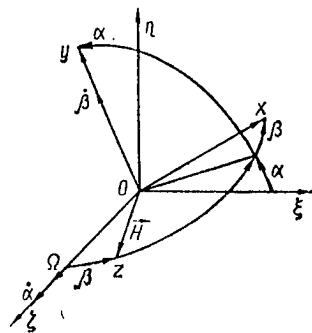

Figure 2

Let us study the dynamics of the gyrotachometer in three cases:

$\Omega^2 \gg \omega^2$; $\Omega^2 \ll \omega^2$; and $\Omega = \omega$. In the first case, let us write differential equation (1) in the form

$$\ddot{\beta} + 2\xi\omega_0\dot{\beta} + \omega_0^2\beta = A\omega \sin \Omega t, \quad (2)$$

where $2\xi\omega_0 = f/I_y$; $\omega_0^2 = [c + H\Omega + (I_z - I_x)\Omega^2]I_y^{-1}$; $A = [H + (I_z + I_y - I_x)\Omega]I_y^{-1}$.

The partial solution of equation (2) is as follows:

$$\beta = \frac{A\omega}{\sqrt{(\omega_0^2 - \Omega^2)^2 + 4\xi^2\omega_0^2\Omega^2}} \sin(\Omega t - \varphi), \quad (3)$$

where

$$\varphi = \text{arctg } 2\xi\omega_0\Omega/(\omega_0^2 - \Omega^2).$$

It follows from (3) that the considered device behaves like a vibratory gyroscope, since it responds to constant angular velocity of the base ω by vibration with frequency Ω , equal to the angular rotational velocity of the gimbal suspension. One can use the resonant operating mode to improve the transfer factor of the device. Resonance begins at $\omega_0 = \Omega$. Expression (3) then assumes the form

$$\beta = \frac{A\omega}{2\xi\omega_0\Omega} \sin\left(\Omega t - \frac{\pi}{2}\right) = -\left(\frac{H}{\Omega} + I_z + I_y - I_x\right) \frac{\omega}{J} \cos \Omega t. \quad (4)$$

Since $\gamma \gg \Omega$, regardless of the damping factor, which is selected on the basis of the required nature of the transition process, one can provide the necessary value of the transfer factor of the gyrotachometer by selecting the ratio between H and Ω upon measurement of small angular velocities ω . The considered device differs advantageously by this from rotary vibratory gyroscopes, since its transfer factor and phase shift φ become less critical to small variations of ω_0 or Ω .

The relation $\Omega_{\text{pe3}} = \omega_0$ is fulfilled for the resonant mode of the gyrotachometer, i.e.,

$$\Omega_{\text{pe3}}^2 = [c + H\Omega_{\text{pe3}} + (I_z - I_x)\Omega_{\text{pe3}}^2] I_y^{-1}. \quad (5)$$

Hence, we find at $I_x = I_y$ the condition of dynamic tuning

$$\Omega_{\text{pe3},2} = \frac{H \pm [H^2 + 4c(2I_x - I_z)]^{1/2}}{2(2I_x - I_z)}. \quad (6)$$

If there is no flexible element in the gyrotachometer ($c = 0$), formula (6) is simplified considerably: $\Omega_{\text{pe31}} = 0$; $\Omega_{\text{pe32}} = H(2I_x - I_z)^{-1}$. Formulas derived for a rotary vibratory gyroscope follow from expressions (5) and (6) as a special case at $H = 0$ [2, 3].

When the device operates in the second frequency band ($\Omega^2 \ll \omega^2$), equation (1) assumes the form

$$I_y \ddot{\beta} + \dot{\beta} + [c + H\Omega - (I_z - I_x) \omega^2 \sin^2 \Omega t] \beta = A\omega \sin \Omega t, \quad (7)$$

and in the third case ($\Omega = \omega$)

$$I_y \ddot{\beta} + \dot{\beta} + [c + H\Omega + (I_z - I_x) \omega^2 \cos^2 \Omega t] \beta = A\omega \sin \Omega t. \quad (8)$$

Using the trigonometric identities, equations (7) and (8) can be written in typical uniform form

$$\ddot{\beta} + 2\xi\omega_0 \dot{\beta} + [\omega_0^2 + q \cos 2\Omega t] \beta = A\omega \sin \Omega t, \quad (9)$$

where $\omega_0^2 = [c + H\Omega + (I_z - I_x) \omega^2 / 2] / I_y^{-1}$; $q_2 = (I_z - I_x) \omega^2 / 2 I_y$, if $\Omega^2 \ll \omega^2$, and $q_1 = q_2$, $\omega_0^2 = [c + H\Omega + (I_z - I_x) \omega^2 / 2] / I_y^{-1}$, if $\Omega = \omega$.

The dynamic stability of the gyrotachometer, the motion of which is described by linear differential equation (9) with periodic coefficient, is provided by selection of the damping factor f (or of the relative damping factor $\zeta = f / 2I_y \omega_0$) according to the inequality [4]

$$\zeta^2 > 1/8 [1 + q\omega_0^{-2} - (1 + 2q\omega_0^{-2})^{1/2}]. \quad (10)$$

Calculation of ζ by formula (10) shows that the dynamic stability of the considered device is easily provided by the parameters of serial gyrotachometers over a wide range of angular velocities ω , since $q\omega^{-2} \ll \ll 1$.

Assuming that inequality (10) is fulfilled, let us represent the partial T-periodic solution of equation (9) in the form of a segment of the Fourier series ($T = \pi/\Omega$) [4]:

$$\beta = a_0 + a_1 \sin \Omega t + b_1 \cos \Omega t + a_2 \sin 2\Omega t + b_2 \cos 2\Omega t. \quad (11)$$

Having substituted (11) into equation (9) and having set the coefficients at identical harmonics equal, we find $a_0 = a_2 = b_2 = 0$; $a_1 = \Delta_1 \Delta^{-1}$; $b_1 = \Delta_2 \Delta^{-1}$; $\Delta_1 = A(\omega_0^2 - \Omega^2)$; $\Delta_2 = -A(2\xi\omega_0\Omega - q/2)$; $\Delta = (\omega_0^2 - \Omega^2 - q/2)(\omega_0^2 - \Omega^2) + 2\xi\omega_0\Omega(2\xi\omega_0\Omega - q/2)$.

Thus, the output signal of the device can be described at $\Omega^2 \ll \omega^2$ and $\Omega = \omega$ by the following mathematical expression

$$\beta = D\omega \sin(\Omega t + \varepsilon), \quad (12)$$

where $D = A(a_1^2 + b_1^2)^{1/2}$; $\varepsilon = \arctg \frac{b_1}{a_1}$. If the resonant operating mode of the gyrotachometer is used ($\omega_0 = \Omega_{\text{рез}}$), formula (12) yields formula (4).

Thus, a two-degree gyrotachometer with rotating gimbal suspension has properties of a one-cage rotary vibratory gyroscope (RVG) [2, 3]. The advantage of the considered device compared to a rotary vibratory gyroscope, besides those noted earlier, is the possibility of realizing a higher natural vibration frequency ω_0 , dependent on additional dynamic components of total stiffness $c_{\Sigma} = c + H\Omega + (I_z - I_x)(\Omega^2 - \omega^2 \sin^2 \Omega t)$.

BIBLIOGRAPHY

1. "Avtokompensatsiya instrumentalnykh pogreshnostey girosistem" [Autocompensation of Instrument Errors of Gyro Systems], Leningrad, 1976.
2. Odintsov, A. A., "Teoriya i raschet giroskopicheskikh priborov" [The Theory and Calculation of Gyroscopes], Kiev, 1985.
3. Pavlovskiy, M. A., "Teoriya giroskopov" [The Theory of Gyroscopes], Kiev, 1986.
4. Yevgenyev, V. S. and M. A. Pavlovskiy, "Study of Systematic Errors of Pendulum-Type Sensitive Elements Upon Intensive Vibration Perturbations," GOD. VTUZOV. TEKHNIЧЕСКАЯ MEKHANIKA, No 19, 1984.

UDC 531.383

DYNAMIC EFFECTS IN GYROSCOPE BASED ON FLEXIBLE SUSPENSION UPON
ACCELERATION OF ITS ROTOR

907F0290E Kiev MEKHANIKA GIROSKOPICHESKIKH SISTEM in Russian, Issue 8,
1989 (manuscript received 10 Oct 87) pp 17-23

[Article by A. V. Zbrutskiy, doctor of technical sciences, L. Yu. Akinfiyeva, candidate of physicomathematical sciences, S. Ya. Svistunov, candidate of technical sciences, and I. B. Kushnirenko, post-graduate student, Kiev Polytechnical Institute]

[Text] Numerous studies of a gyroscope with flexible suspension [1-5] have not devoted attention to the acceleration of its rotor, which is important in solving the problem of reducing the readiness time of the devices.

A method is proposed in this paper and the characteristic features of a gyroscope upon acceleration of its rotor are studied.

Analysis of the nonlinear equations of motion, which correspond to different kinematic layouts of gyroscopes with flexible suspension (layouts in the form of a rotor with one- and two-race and inertialless flexible suspensions), permits one [5, 6] to write the generalized mathematical model of a gyroscope with flexible suspension in the form

$$\ddot{\psi} + b_{12} \dot{\gamma} \dot{\theta} + (b_{13} \dot{\gamma}^2 + b_{14}) \psi = \varepsilon M_1, \quad (1)$$

$$\ddot{\theta} - b_{22} \dot{\gamma} \dot{\psi} + (b_{23} \dot{\gamma}^2 + b_{24}) \theta = \varepsilon M_2;$$

$$\ddot{\gamma} + \omega_{30}^2 \Delta \gamma + b_{42} \ddot{\varphi} = \varepsilon m_{40}, \quad (2)$$

$$\ddot{\varphi} + \ddot{\gamma} + b_{30} \varphi = \varepsilon M_3,$$

where coefficients b_{ij} are dependent on the inertial and elastic properties of the system.

The differences of systems of differential equations (1) and (2) for different kinematic layouts of gyroscopes with flexible suspension are reflected in the specific type of coefficients b_{ij} .

As follows from system of equations (1) and (2), the motion of the rotor with respect to coordinates γ and φ is independent in linear approximation of motion with respect to the remaining coordinates. Thus, one can study the problem of acceleration of a gyroscope with flexible suspension by equations (2), while one can study the motion of the rotor with respect to the drive motor shaft by equations (1).

Let us assume that coefficient b_{30} , which characterizes the stiffness of the flexible suspension, is large and the inertial properties of the rotor can be disregarded with respect to angle φ , i.e., one can assume that $\ddot{\varphi} = 0$ in equations of motion (2).

The last equation of systems (2) is reduced by replacement of variable $\dot{\gamma} = z$, $\ddot{\gamma} = \dot{z}$ to an equation with separable variables $\dot{z} + m_{c0}z^2 = m_g$.

Integrating this equation at initial conditions $\gamma(0) = 0$, $\dot{\gamma}(0) = 0$, we find

$$\dot{\gamma} = \frac{1}{m_{c0}} \frac{e^{2Lt} - 1}{e^{2Lt} + 1}, \quad (3)$$

where $L = m_g m_{c0}$.

Having substituted (3) into the first equation of system (2), we find

$$\varphi = - \frac{8m_g L}{b_{30}} \frac{e^{2Lt}}{(e^{2Lt} + 1)^2}. \quad (4)$$

Let us estimate the effect of the inertia of the rotor during its motion along coordinate φ on the law of variation of angular velocity (3) and angle (4).

Since there are no methods of constructing the general solution of system of nonlinear equations (2), they can be integrated numerically on the digital computer. Let us solve this system by the fourth-order Runge-Kutta method, reducing to the form

$$\begin{aligned}\ddot{\gamma} &= (\varepsilon M_3 (b_{42} - 1) - m_g + m_{c0} \dot{\gamma}^2 - b_{30} b_{42} \varphi) / (b_{42} - 1), \\ \ddot{\varphi} &= (m_g - m_{c0} \dot{\gamma}^2 + b_{30} \varphi) / (b_{42} - 1).\end{aligned}\quad (5)$$

After substitution of variables $\gamma = x_1$, $\varphi = x_2$, $\dot{\gamma} = x_3$, $\dot{\varphi} = x_4$ we write $\dot{\gamma} = \dot{x}_1$, $\dot{\varphi} = \dot{x}_2$, $\dot{x}_1 = x_3$, $\dot{x}_2 = x_4$. Finally, the canonical form of system (2) assumes the form

$$\begin{aligned}\dot{x}_1 &= x_3, \quad \dot{x}_2 = x_4, \\ \dot{x}_3 &= (\varepsilon M_3 (b_{42} - 1) - m_g + m_{c0} x_3^2 - b_{30} b_{42} x_2) / (b_{42} - 1), \\ \dot{x}_4 &= (m_g - m_{c0} x_3^2 + b_{30} x_2) / (b_{42} - 1).\end{aligned}\quad (6)$$

Let us assume that the engine torque is constant. The value of $m_g = m_{g1}$ on the first time interval ($\dot{\gamma}_{\text{TEK}} < 0.8 \dot{\gamma}_0$), and $m_g = m_{g2}$ on the second time interval ($0.8 \dot{\gamma}_0 < \dot{\gamma}_{\text{TEK}}$).

System of equations (6) is integrated numerically on the SM-4 digital computer with values of the parameters of $\dot{\gamma}_0 = 1,500 \text{ s}^{-1}$, $b_{42} = 1 \text{ N}\cdot\text{m}$, $b_{30} = 10^{-8} \text{ N}\cdot\text{m}$, $m_{c0} = 20 \text{ s}^{-2}$, $m_g = 450 \text{ N}\cdot\text{m}$ and at initial conditions $\gamma(0) = 0$, $\dot{\gamma}(0) = 0$.

The results, found analytically without regard to elastic deformations of the rotor with respect to the shaft axis by angle φ and by the numerical method with regard to the flexible properties of the rotor, coincide.

It is obvious from analysis of these results that the consideration of the inertia of the rotor results in additional vibrations along coordinate φ . This must be taken into account when designing the suspension and in strength calculation of it.

It frequently becomes necessary in practice to force acceleration of the rotor within a limited time t_p . It is desirable that $\dot{\gamma}$ approach $\dot{\gamma}_0$ smoothly (without jumps and vibrations), i.e., that it correspond to law (3).

Function (3) can be approximated by a function of type

$$\dot{\gamma} = \dot{\gamma}_0 (1 - e^{-at}) \quad (7)$$

so that at

$$t \leq t_p \quad \left| \frac{\dot{\gamma} - \dot{\gamma}_0}{\dot{\gamma}_0} \right| \leq 0,03, \quad \alpha = 1/t_p. \quad (8)$$

We find with respect to the law of variation of the angular rotational velocity of the engine shaft (7) with regard to (8) from system of equations (2)

$$\varphi = - \frac{\dot{\gamma}_0 \alpha e^{-\alpha t}}{\alpha^2 + \omega^2}, \quad (9)$$

$$m_g = m_{c0} \dot{\gamma}_0^2 - e^{-\alpha t} \left[\frac{\dot{\gamma}_0 \alpha^3 b_{42}}{\alpha^2 + \omega^2} - \dot{\gamma}_0 \alpha + 2m_{c0} \dot{\gamma}_0^2 - m_{c0} \dot{\gamma}_0^2 e^{-\alpha t} \right]. \quad (10)$$

The graphs of function $m_A(t)$ at different values of t_p are shown in the figure, where curve (1) corresponds to $t_p = 1$ s, curve 2 corresponds to $t_p = 0.5$ s, and curve 3 corresponds to $t_p = 0.1$ s.

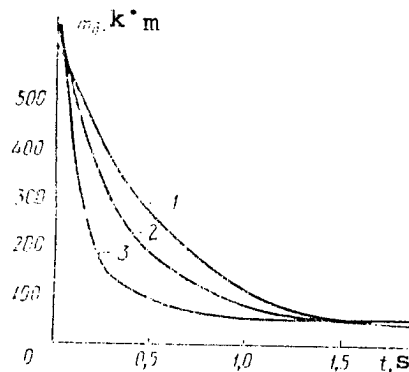

It is also of interest to study the motion of the rotor with respect to angular coordinates θ and ψ , which characterize its dynamic properties as a gage of navigation instruments. Let us first study the motion of the gyroscope in linear approximation.

Let us rewrite system of equations (1) and (2) with regard to (7) in the form

$$\begin{aligned}
\ddot{\psi} + b_{12}\dot{\gamma}_0\dot{\theta} + [b_{13}\dot{\gamma}_0^2 + b_{14}]\dot{\psi} &= b_{12}\dot{\gamma}_0e^{-\alpha t}\dot{\theta} - b_{13}\dot{\gamma}_0^2(-2e^{-\alpha t} + e^{-2\alpha t})\dot{\psi} - \\
&- b_{15}\dot{\gamma}_0\omega_z \left[\cos(\dot{\gamma}_0 t) \cos\left(\frac{\dot{\gamma}_0}{\alpha} e^{-\alpha t}\right) - \sin(\dot{\gamma}_0 t) \sin\left(\frac{\dot{\gamma}_0}{\alpha} e^{-\alpha t}\right) \right] + \\
&+ b_{15}\dot{\gamma}_0e^{-\alpha t}\omega_z \left[\cos(\dot{\gamma}_0 t) \cos\left(\frac{\dot{\gamma}_0}{\alpha} e^{-\alpha t}\right) - \sin(\dot{\gamma}_0 t) \sin\left(\frac{\dot{\gamma}_0}{\alpha} e^{-\alpha t}\right) \right] + \\
&+ 2h_3[\dot{\psi} + \dot{\gamma}_0\theta - \dot{\gamma}_0e^{-\alpha t}]; \\
\ddot{\theta} - b_{22}\dot{\gamma}_0\dot{\psi} + [b_{23}\dot{\gamma}_0^2 + b_{24}]\dot{\theta} &= -b_{22}\dot{\gamma}_0e^{-\alpha t}\dot{\psi} - b_{23}\dot{\gamma}_0^2(-2e^{-\alpha t} + e^{-2\alpha t})\dot{\theta} + \\
&+ b_{25}\dot{\gamma}_0\omega_z \left[\sin(\dot{\gamma}_0 t) \cos\left(\frac{\dot{\gamma}_0}{\alpha} e^{-\alpha t}\right) + \cos(\dot{\gamma}_0 t) \sin\left(\frac{\dot{\gamma}_0}{\alpha} e^{-\alpha t}\right) \right] - b_{25}\dot{\gamma}_0e^{-\alpha t}\omega_z \times \\
&\times \left[\sin(\dot{\gamma}_0 t) \cos\left(\frac{\dot{\gamma}_0}{\alpha} e^{-\alpha t}\right) + \cos(\dot{\gamma}_0 t) \sin\left(\frac{\dot{\gamma}_0}{\alpha} e^{-\alpha t}\right) \right] - \\
&- 2h_2[\dot{\theta} + \dot{\gamma}_0\psi - \dot{\gamma}_0e^{-\alpha t}\psi].
\end{aligned} \tag{11}$$

The considered gyroscope based on a flexible suspension is a vibratory system. As studies show, vibrations of the rotor with respect to the drive motor shaft occur with period that is considerably less than the acceleration time by coordinate γ . Therefore, complex motion of the rotor, consisting of rotation together with the shaft and deviation from it, can be divided into "fast" (vibrations with respect to the shaft) and "slow" (rotation with respect to the shaft, including acceleration), and one can use N. N. Bogolyubov's method of perturbations [7] to study the motion of the rotor upon acceleration, performing an averaging operation with respect to the "fast" time. The terms in system of equations (11), which contain the multiplier $e^{-k\alpha t}$ ($k = 1, 2$) that characterizes the "slow" motion (acceleration), are assumed constant upon averaging, i.e., they are "frozen." Thus, we find a system of equations with coefficients, quasi-constant with respect to "fast" motions, in the acceleration phase for study of the motion of the rotor with respect to θ and ψ .

Having used the method of averaging [8], let us find the solutions of equations (11) in the form

$$\begin{aligned}
\psi &= \sum_{j=1}^2 C_j e^{i\omega_j t} + D_j e^{-i\omega_j t}, \\
\theta &= \sum_{j=1}^2 \kappa_j (C_j e^{i\omega_j t} - D_j e^{-i\omega_j t}).
\end{aligned} \tag{12}$$

Having made the necessary transformations and having completed the averaging procedure, we find a system of equations of first approximation

$$\begin{aligned}
 \dot{C}_1 = & -\frac{\varepsilon}{2\kappa_{11}} (C_1 \{2\dot{\gamma}_0 e^{-\alpha t} (h_2 + h_3) - i [\dot{\gamma}_0^2 e^{-\alpha t} (b_{12} + b_{22}) + \\
 & + \dot{\gamma}_0^2 (-2e^{-\alpha t} + e^{-2\alpha t})(b_{13} + b_{23})]\} + \frac{1}{2} \dot{\gamma}_0 \omega_z (1 - e^{-\alpha t}) \times \\
 \times \sin\left(\frac{\dot{\gamma}_0}{\alpha} e^{-\alpha t}\right) (b_{15} + b_{25}) - i \frac{1}{2} \dot{\gamma}_0 \omega_z (1 - e^{-\alpha t}) \cos\left(\frac{\dot{\gamma}_0}{\alpha} e^{-\alpha t}\right) (b_{15} + b_{25})), & \quad (13) \\
 \dot{D}_1 = & -\frac{\varepsilon}{2\kappa_{11}} D_1 \{2\dot{\gamma}_0 e^{-\alpha t} (h_2 + h_3) + i [\dot{\gamma}_0^2 e^{-\alpha t} \times (b_{12} + b_{22}) + \\
 & + \dot{\gamma}_0^2 (-2e^{-\alpha t} + e^{-2\alpha t})(b_{13} + b_{23})]\} + \frac{1}{2} \dot{\gamma}_0 \omega_z (1 - e^{-\alpha t}) \times \\
 \times \sin\left(\frac{\dot{\gamma}_0}{\alpha} e^{-\alpha t}\right) (b_{15} + b_{25}) + i \frac{1}{2} \dot{\gamma}_0 \omega_z (1 - e^{-\alpha t}) \cos\left(\frac{\dot{\gamma}_0}{\alpha} e^{-\alpha t}\right) (b_{15} + b_{25}). &
 \end{aligned}$$

The equations for variables C_2 and D_2 describe the attenuating vibrations of the system with second natural frequency and are of no practical interest in the given postulation of the problem [5].

As follows from analysis of system (13), the variable coefficients are determined by variation of the angular rotational velocity of the motor shaft during acceleration. Therefore, the solution of equations (13) can be divided into two steps: I--corresponding to acceleration of the motor shaft when system of equations (13) has variable coefficients and II--corresponding to motion of a system with angular natural rotational velocity close to constant ($\dot{\gamma}_0 = \text{const}$). Equations (13) will have constant coefficients.

The general solution of system (13) must be found to study the motion of the gyroscope in the transient mode. Since the equations of the system are unrelated and since C_1 and D_1 are complex conjugate values, it is sufficient to construct the solution of one of the equations of the system, for example, of the first equation.

Let us rewrite it in the form

$$\dot{C}_1 = C_1 [u(t) + iv(t)] + f(t) - ig(t), \quad (14)$$

where

$$\begin{aligned}
 u(t) = & -\frac{\varepsilon}{2\kappa_{11}} \dot{\gamma}_0 (h_2 + h_3) e^{-\alpha t}; \\
 v(t) = & \frac{\varepsilon}{2\kappa_{11}} [\dot{\gamma}_0^2 e^{-\alpha t} (b_{12} + b_{22}) + \dot{\gamma}_0^2 (-2e^{-\alpha t} + e^{-2\alpha t})(b_{13} + b_{23})];
 \end{aligned}$$

$$f(t) = -\frac{\varepsilon}{4\kappa_{11}} \dot{\gamma}_0 \omega_z (1 - e^{-\alpha t}) \sin\left(\frac{\dot{\gamma}_0 e^{-\alpha t}}{\alpha}\right) (b_{15} + b_{25});$$

$$g(t) = -\frac{\varepsilon}{4\kappa_{11}} \dot{\gamma}_0 \omega_z (1 - e^{-\alpha t}) \cos\left(\frac{\dot{\gamma}_0 e^{-\alpha t}}{\alpha}\right) (b_{15} + b_{25}).$$

Equation (14) is a first-order inhomogeneous linear equation with variable coefficients. Solving it by the method of variation of an arbitrary constant, we find in the first step

$$C_1 = L + iM, \quad (15)$$

where

$$L = \frac{1}{2} (1 - K_1 t + K_2) [K_3 (\cos \alpha + \cos \beta) + K_4 (\sin \alpha - \sin \beta) + K_5 (\cos \gamma + \cos \varphi) + K_6 (\cos \gamma - \cos \varphi) + K_7 (\sin \gamma - \sin \varphi) - K_8 (\sin \gamma + \sin \varphi)] + \frac{1}{2} \lambda \Delta_1; \quad (16)$$

$$M = \frac{1}{2} (1 - K_1 t - K_2) [K_3 (\sin \alpha + \sin \beta) + K_4 (\cos \beta - \cos \alpha) + K_5 (\sin \gamma + \sin \varphi) + K_6 (\sin \gamma - \sin \varphi) + K_7 (\cos \varphi + \cos \gamma) + K_8 (\cos \gamma + \cos \varphi)] + \frac{1}{2} \lambda \Delta_2,$$

and α , β , γ , and φ are time functions, while K_i ($i = \overline{1, 7}$) are coefficients that are dependent on the parameters of system (14) (they are not presented due to cumbersomeness), and Δ_1 and Δ_2 are sums that contain terms of higher orders of smallness with respect to t .

Let us find from (15) the conditions on the second step ($t \geq t_p$) at $t = t_p$: $C_1 = L^* + iM^*$.

The solution of equation (14) on the second step has the form

$$C_1 = e^{-\frac{\varepsilon}{2}(s_{12} + is_{11})t} + (\mu + i\eta) + \frac{is_{10}}{s_{12} + is_{11}}, \quad (17)$$

where

$$\mu = L^* - \frac{s_{11}s_{10}}{s_{11}^2 + s_{12}^2}; \quad \eta = M^* - \frac{s_{12}s_{10}}{s_{11}^2 + s_{12}^2}.$$

Let us derive from (14) and (17) the law of motion of the rotor over the entire time interval from the moment of acceleration until it reaches the steady mode

$$C_1 = L(t < t_p) + iM(t < t_p) + e^{-\frac{\epsilon}{2}(s_{12} + i s_{11})(t - t_p)} \left[L^* - \frac{s_{11}s_{16}}{s_{11}^2 + s_{12}^2} + \right. \quad (18) \\ \left. + i \left(M^* - \frac{s_{12}s_{16}}{s_{11}^2 + s_{12}^2} \right) \right] + \frac{i s_{16}s_{12}}{s_{11}^2 + s_{12}^2}.$$

Taking relations (12) into account, we find from equation

$$\psi = 2 \cos \dot{\gamma}_0 t \left[L(t < t_p) + e^{-\frac{\epsilon}{2} s_{12}(t - t_p)} \left\{ \cos \left[-\frac{\epsilon}{2} s_{11}(t - t_p) \right] \times \right. \right. \\ \left. \times \left[L^* - \frac{s_{11}s_{16}}{s_{11}^2 + s_{12}^2} \right] + \sin \left[-\frac{\epsilon}{2} s_{11}(t - t_p) \right] \left[M^* - \frac{s_{12}s_{16}}{s_{11}^2 + s_{12}^2} \right] \right\} + \\ + 2 \sin \dot{\gamma}_0 t \left[M(t < t_p) + e^{-\frac{\epsilon}{2} s_{11}(t - t_p)} \left\{ \cos \left[-\frac{\epsilon}{2} s_{11}(t - t_p) \right] \times \right. \right. \\ \left. \times \left[M^* - \frac{s_{12}s_{16}}{s_{11}^2 + s_{12}^2} \right] - \sin \left[-\frac{\epsilon}{2} s_{11}(t - t_p) \right] \left[L^* - \frac{s_{11}s_{16}}{s_{11}^2 + s_{12}^2} \right] \right\} + \\ \left. + \frac{s_{16}s_{12}}{s_{11}^2 + s_{12}^2} \right], \\ \theta = -2 \sin \dot{\gamma}_0 t \left[L(t < t_p) + e^{-\frac{\epsilon}{2} s_{12}(t - t_p)} \left\{ \cos \left[-\frac{\epsilon}{2} s_{11}(t - t_p) \right] \times \right. \right. \\ \left. \times \left[L^* - \frac{s_{11}s_{16}}{s_{11}^2 + s_{12}^2} \right] + \sin \left[-\frac{\epsilon}{2} s_{11}(t - t_p) \right] \left[M^* - \frac{s_{12}s_{16}}{s_{11}^2 + s_{12}^2} \right] \right\} + \\ + 2 \cos \dot{\gamma}_0 t \left[M(t < t_p) + e^{-\frac{\epsilon}{2} s_{11}(t - t_p)} \left\{ \cos \left[-\frac{\epsilon}{2} s_{11}(t - t_p) \right] \times \right. \right. \\ \left. \times \left[M^* - \frac{s_{12}s_{16}}{s_{11}^2 + s_{12}^2} \right] - \sin \left[-\frac{\epsilon}{2} s_{11}(t - t_p) \right] \left[L^* - \frac{s_{11}s_{16}}{s_{11}^2 + s_{12}^2} \right] \right\} + \frac{s_{16}s_{12}}{s_{11}^2 + s_{12}^2} \right]$$

Thus, the law of variation of angular velocity (7) can be taken as the initial law in determination of the required torque of the motor in the forced acceleration problem (10).

The motion of the rotor with respect to coordinates ψ and θ is a transient vibration process that results in increased dynamic effects on the flexible elements of the suspension. This nature of motion should be taken into account when guaranteeing the strength of the suspension.

BIBLIOGRAPHY

1. Abramov, R. A., "Oshibki dinamicheski nastraivayemykh giroskopov" [Errors of Tuned Rotor Gyroscopes], Moscow, 1985.
2. Brozgul, L. I. and Ye. L. Smirnov, "Vibratsionnyye giroskopy" [Vibratory Gyroscopes], Moscow, 1970.
3. Vlasov, Yu. B. and O. M. Filonov, "Rotornyye vibratsionnyye giroskopy v sistemakh navigatsii" [Rotary Vibratory Gyroscopes in Navigation Systems], Leningrad, 1980.
4. Novikov, L. Z. and M. Yu. Shatalov, "Mekhaniki dinamicheski nastraivayemykh giroskopov" [The Mechanics of Tuned Rotor Gyroscopes], Moscow, 1985.
5. Pavlovskiy, M. A. and A. V. Zbrutskiy, "Dinamika rotornykh vibratsionnykh giroskopov" [The Dynamics of Rotary Vibratory Gyroscopes], Kiev, 1984.
6. Kushnirenko, I. B., "Motion of a Gyroscope Motor Based on a Flexible Suspension During Acceleration of It," MEKHANIKA GIROSOPICHESKIKH SISTEM, No 7, 1988.
7. Bogolyubov, N. N., "Method of Perturbations in Nonlinear Mechanics," TRUDY INSTITUTA STROITELNOY MEKHANIKI AKADEMII NAUK UKRAINSKOY SSR, No 14, 1950.
8. Bogolyubov, N. N. and Yu. A. Mitropolskiy, "Asimptoticheskiye metody v teorii nelineynykh kolebaniy" [Asymptotic Methods in Nonlinear Vibration Theory], Moscow, 1976.

UDC 531.383

ERRORS OF ANGULAR-RATE SENSOR ON TUNED ROTOR GYROSCOPE

907F0290F Kiev MEKHANIKA GIROSKOPICHESKIKH SISTEM in Russian, Issue 8, 1989 (manuscript received 10 Nov 87) pp 24-29

[Article by A. V. Zbrutskiy, doctor of technical sciences, and S. A. Shakhov, engineer, Kiev Polytechnical Institute]

[Text] The dynamics and errors of vibratory gyroscopes (VG) with flexible suspension as a sensor of small angular deviations of the base or as an angular-rate sensor in the steady mode were studied in sufficient detail [1-3] in the case of a free rotor of vibratory gyroscopes. At the same time, problems of design of the angular-rate sensor (IUS) on a tuned rotor gyroscope (DNG) with the required speed [4] have hardly been studied. A model of the errors of the angular-rate sensors on tuned rotor gyroscopes with symmetrical flexible suspension is developed in this article.

As shown in [4], a two-race DNG can serve as a sensor of small angular deviations of the base in the transient mode of the gyroscope, and as an angular-rate sensor in the steady mode. Errors caused by friction losses, asymmetry of the dynamic parameters, angular and translational accelerations and vibrations of the base, and also by cross-coupling due to inaccurate dynamic tuning, which as an effect only during an initial error distinct from zero, are inherent to DNG in both cases. The speed of the DNG reaches several tens of seconds [4], which does not satisfy current requirements on the angular-rate sensor. Compensation feedback (OS) with respect to moment, by selection of the transfer function of which one can increase both the speed and can reduce the cross-coupling of the IUS, can be introduced.

The equations of motion of the tuned rotor gyroscope can be written in complex form

$$e_1 \ddot{\varphi} + (e_3 + iH) \dot{\varphi} + (C + ie_3 \dot{\gamma}) \varphi = -e_1 \dot{\Omega} - ie_6 \Omega - I_{MД} K_{MД} + M_0, \quad (1)$$

где $\varphi = \alpha + i\beta$; $\Omega = \Omega_z + i\Omega_y$; $e_1 = B_3 + C_1$; $e_3 = K_3 + K_1$; $e_6 =$

$$= (A_3 + A_1 + C_1 - B_1)\dot{\gamma}; \quad H = (A_3 + 2C_1)\dot{\gamma}; \quad C = 2C_{66} + (A_1 - B_1 - C_1)\dot{\gamma}^2; \quad M_0 = M_1 + iM_2; \quad i^2 = -1; \quad \alpha, \beta$$

are angles of deflection of the rotor of the tuned rotor gyroscope in a coordinate system unbound to the drive shaft, Ω_y and Ω_z are projections of the vector of the angular rotational velocity of the base onto the axes of sensitivity of the tuned rotor gyroscope, A_j , B_j , and C_j are axial and equatorial moments of inertia of the center rings ($j = 1, 2$) of the flexible suspension (UP) and of the rotor ($j = 3$), k_j are coefficients of the viscous frictional moments of the center rings

($j = 1, 2$) and of the rotor ($j = 3$), $\dot{\gamma}$ is the angular rotational velocity of the drive motor shaft, C_{66} is the angular stiffness of the flexible axis of the tuned rotor gyroscope, M_1 and M_2 are the perturbing moments of the angular-rate sensor with respect to the axes of sensitivity, caused by parameters of both the tuned rotor gyroscope and of the elements of the feedback circuit, I_{MD} is the control current in the torque motor (MD) circuit, the functional dependence of which on time t and on the parameters of the tuned rotor gyroscope is determined by the selected feedback circuit, and K_{MD} is the characteristic slope of the torque motor.

Taking into account that the output signal in the compensation operating mode of the angular-rate sensor is the current in the torque motor circuit, we find from expression (1)

$$I_{MD} = [-ie_6\Omega + e_1\dot{\Omega} + M_0 + e_1\ddot{\varphi} - (e_3 + iH)\dot{\varphi} - (C + ie_3\dot{\gamma})\varphi]K_{MD}^{-1}. \quad (2)$$

Hence, it follows that the angular drift speed Ω is measured by the angular-rate sensor with some error, determined both by the dynamics of the tuned rotor gyroscope and by moments M_0 , determined by the characteristics of the angular-rate sensor. Let us compile a mathematical model of the errors of the angular-rate sensor in the steady operating mode, since the dynamic errors of the sensor are considerably dependent on the selected feedback circuit. To do this, let us introduce the following notations: m_j is the mass of the center rings ($j = 1, 2$), of the rotor ($j = 3$) of the tuned rotor gyroscope and of the drive shaft ($j = 0$), $\vec{r}_{cj} = \{r_{cixj}; r_{cyj}; r_{czj}\}$ is the displacement vector of the centers of mass of the center rings ($j = 1, 2$) and of the rotor ($j = 3$), r_{12x} is the nonintersection of the flexible suspension axes, and $\vec{W} = \{W_x; W_y; W_z\}$ is the vector of translational acceleration of the base.

The useful signal of the angular-rate sensor that characterizes the angular drift speed of the base is selected in the form $I_{\Omega} = -(ie_6/K_{\Omega})\Omega$. The remaining elements of the right side of expression (2) are then an error of the sensor, which in the steady mode has the form

$$I_n = [M_0 - (C + ie_3\dot{\gamma})\Phi]K_{\Omega}^{-1}. \quad (3)$$

Let us consider the components of moment M_0 , which determine the errors of the angular-rate sensor.

The moments that occur in the flexible suspension of the angular-rate sensor during translational accelerations of the base ($W_y = \text{const}$ and $W_z = \text{const}$) can be written in the form

$$M_W = -(m_3r_{c3x3} + 0,5m_1r_{c1x1})W - 0,5(m_3r_{12x} + 0,5m_2r_{c2x2})W^*, \\ W^* = W_z + iW_y. \quad (4)$$

They characterize the error of the sensor, dependent on displacement of the centers of mass and nonintersection of the axes of the flexible suspension in the axial direction.

The radial unbalance of the center rings and rotor of the tuned rotor gyroscope determine the errors of the angular-rate sensor in the case of action on the translational vibration sensor of the base $W_x = W_{x0} \cos n_1 t$; $W_y = W_{y0} \cos n_2 t$; $W_z = W_{z0} \cos n_3 t$ at frequency relations $n_1 = \dot{\gamma}$; $n_2 = n_3 = 2\dot{\gamma}$.

The perturbing moments can be written as follows after averaging on a time interval that considerably exceeds the period of natural rotation of the drive shaft:

$$M_{W(\dot{\gamma})} = 0,5(m_3r_{c3x3} + m_1r_{c1y1})W_{x0}; \quad (5)$$

$$M_{W(2\dot{\gamma})} = 0,25(m_3r_{12x} + m_1r_{c1x1} + m_2r_{c2x2})(W_{y0} + iW_{z0}). \quad (6)$$

As follows from expressions (4)-(6), the errors of the angular-rate sensor are dependent on the modulus and mutual orientation of vectors

\vec{r}_{c_j} ($j = 1, 2, 3$), which characterize the errors in manufacture and assembly of the sensitive element. The center rings, the mass of which is comparable to that of the rotor of the tuned rotor gyroscope, have a significant influence on the errors of the small angular-rate sensor.

It becomes necessary in this regard not only to adjust the races dynamically to ensure the resonant operating mode of the tuned rotor gyroscope, but also to balance them statically.

A quadrature moment M_{KB} , the cause of which is correlation between displacements of the rotor upon elastic deformations, determined by asymmetry of the spatial arrangement of the pliable elements of the suspension, by rotations of their principal stiffness axes, by different dimensions, by violation of spatial symmetry, and by instrument errors in manufacture and assembly of the suspension, also occurs under the action of translational accelerations and vibrations of the base in the angular-rate sensor. Studies show that the effect of instrument errors in the quadrature moment of the angular-rate sensor increases considerably (tens of times) in the presence of pliable center rings.

Having denoted the stiffness matrix of the flexible suspension by $\|C_{ij}\|$, where c_{jj} ($j = 1, 2, 3$) are coefficients of the translational stiffnesses of the flexible suspension and C_{jj} ($j = 4, 5, 6$) are the coefficients of angular stiffnesses of the flexible suspension, let us write the components of the quadrature moment.

The moment caused by cross-couplings between the translational and angular displacements of the rotor are

$$M_{KB1} = 0,5m_3 (C_{52} + C_{63}) (r_{c3y3}W_y C_{22}^{-1} + i r_{c3z3}W_z C_{33}^{-1}). \quad (7)$$

It is characterized by stiffness coefficients C_{52} and C_{63} and by radial displacements of the center of mass of the rotor of the tuned rotor gyroscope.

The moment caused by correlation between the translational displacements of the rotor in the axial and radial directions is:

$$M_{KB2} = \frac{1}{2} \left[\frac{C_{13}}{2C_{22}} r_{c3y3} - \frac{C_{12}}{2C_{22}} r_{c3z3} - \frac{C_{23}}{C_{22}} \frac{C_{22}}{C_{22} - 4m_3\dot{\gamma}^2} r_{12x} - \right. \\ \left. - 2 \frac{C_{23}}{C_{22}} \frac{m_3\dot{\gamma}^2 r_{c3x3}}{C_{22} - 4\dot{\gamma}^2 m_3} \right] m_3 (W_y + iW_z). \quad (8)$$

Expression (8) determines the total effect of the axial and radial unbalance of the rotor and of linear accelerations in these directions on the error of the angular-rate sensor.

The moment caused by cross-couplings between the angular displacements of the rotor is:

$$M_{KB3} = -\frac{A_0}{2(A_0 + A_3)} \frac{C_{54} - C_{64}}{C_{44}} \left[(r_{z0}(m_0 + m_3) + m_3 r_{c3z3}) W_y + i(r_{y0}(m_0 + m_3) + m_3 r_{c3y3}) W_z \right] \quad (9)$$

where r_{y0} and r_{z0} is the displacement of the point of suspension of the rotor of the axis of symmetry of the shaft with respect to the rotational axis.

Moment (9), characterized by stiffness coefficients C_{54} and C_{64} , occurs upon displacement of the center of mass of the system with respect to the rotational axis of the drive shaft.

The moment caused by dynamic unbalance of the rotor δ_θ and δ_ψ is:

$$M_{KB4} = 0,5A_3(\delta_\theta + \delta_\psi) \left[(r_{z0}(m_0 + m_3) + r_{c3z3}m_3) W_y + i(r_{y0}(m_0 + m_3) + r_{c3y3}m_3) W_z \right] (A_0 + A_3)^{-1} \quad (10)$$

It acts along the suspension axes of the tuned rotor gyroscope at nonperpendicularity of the axes of the flexible suspension to the rotational axis of the shaft. The noncoincidence of the flexible axes with the rotational plane of the drive shaft is caused by dynamic unbalance of the rotor or by instrument errors.

Analysis of quadrature moment $M_{KB} = \sum_{i=1}^1 M_{KBi}$ shows that the stiffness of the pliable elements of the center rings must be exceeded by an order or more with respect to the corresponding stiffnesses of the flexible elements of the suspension, when the center rings can be considered as absolutely rigid, to eliminate it. The arrangement of the flexible elements of each center ring should satisfy the symmetry with respect to the rotational axis of the drive shaft, while the entire flexible suspension, after rotation by 90° , should be identical to some suspension, symmetrical with respect to the plane perpendicular to the suspension axis.

Besides the above moments, a flexible element proportional to the product of rotor displacements with respect to two mutually perpendicular axes acts on the angular-rate sensor due to inertial loads. Taking into account that displacement of the center of mass of the flexible system is directly proportional to the effective acceleration, the perturbing moment in the body axes system can be written as follows:

$$M_{yz} = \frac{m_4^2 W_x}{C_{11}} \left(\frac{C_{22} - C_{11}}{C_{22}} W_y + i \frac{C_{33} - C_{11}}{C_{33}} W_z \right), \quad (11)$$

where m_4 is the reduced mass of the rotor of the tuned rotor gyroscope.

As follows from expression (11), the translational stiffnesses of the flexible suspension in the axial and radial directions must coincide to eliminate moment M_{yz} . This can be provided by rotating the principal stiffness axes of the pliable elements of the flexible suspension.

Besides translational accelerations and vibrations of the base, angular vibrations with double rotational frequency of the drive $\Omega_y = \Omega_0 \cos 2\dot{\gamma}t$; $\Omega_z = \Omega_0 \sin 2\dot{\gamma}t$ also affect the errors of the angular-rate sensor. The perturbing moment caused by them characterizes the nonidentity of the center rings of the flexible suspension and its systematic component has the form

$$M_{\Omega(2\dot{\gamma})} = 0,5(A_1 - B_1 + 3C_1 - A_2 + B_2 - 3C_2)\dot{\gamma}\Omega_0. \quad (12)$$

According to expression (12), there is no drift upon angular vibration of the base at frequency $2\dot{\gamma}$ in an angular-rate sensor on a two-race tuned rotor gyroscope with parameters $A_1 = A_2$, $B_1 = B_2$, and $C_1 = C_2$. Thus, the symmetry of the inertial characteristics of the suspension of the sensitive element with respect to its axes makes the sensor insensitive to angular vibrations, the vector of which lies in a plane perpendicular to the rotational axis of the shaft.

The residual stiffness ($C \neq 0$) and the viscous friction of the gaseous medium of the sensor make a considerable contribution to the errors of the angular-rate sensor. They cause a perturbing moment (see (3)) only upon deflection of the rotor from the zero position by angle φ :

$$M_c = [2C_{\theta\theta} + (A_1 - B_1 - C_1)\dot{\gamma}^2 + ie_3\dot{\gamma}]\varphi. \quad (13)$$

Angle φ is a consequence of the action of the torque motor on the rotor of the tuned rotor gyroscope in a compensating angular-rate sensor in the absence of translational rotation of the base. The current occurring in the circuit of the torque motor is determined by the error φ_0 between the angular deflection sensor (IU) of the sensitive element and the rotor of the tuned rotor gyroscope in its initial undeflected position, the noise V_0 of the angular deflection sensor, and U_0 of the electric circuit of the feedback circuit. Substituting these values

into (13) with regard to application of signals V_0 and U_0 to the angular deflections of the rotor $V_\varphi = V_0 K_{ny}^{-1}$; $U_\varphi = L^{-1}[U_0/(W_{oc}(p)K_{ny})]$, where K_{ny} is the steepness of the angular deflection sensor, L^{-1} is an operator of the inverse Laplace transform, and $W_{oc}(p)$ is the transfer function of the feedback circuit, we write

$$M_c = [2C_{60} + (A_1 - B_1 - C_1)\dot{\gamma}^2 + ie_3\dot{\gamma}](\varphi_0 + U_\varphi + V_\varphi). \quad (14)$$

This expression characterizes the errors of the angular-rate sensor, occurring in the presence of a feedback circuit. They can be reduced by selecting the elements of the feedback circuit and of the transfer function of the feedback.

Thus, expressions (4)-(14) permit one to estimate the error of the angular-rate sensor if there are different perturbing factors. When they are substituted into expression (3), we find the mathematical models of the errors of the angular-rate sensor:

$$\begin{aligned} I_n = & 0,5 [2(m_3 r_{c3x3} + 0,5m_1 r_{c1x}) (W_z + iW_y) + (m_3 r_{12x} + 0,5m_2 r_{c2x2}) \times \\ & \times (W_z + iW_y) + (m_3 r_{c3y3} + m_1 r_{c1y1}) W_{x0} + 0,5 (m_3 r_{12x} + m_1 r_{c1x1} + \\ & + m_2 r_{c2x2}) (W_{y0} + iW_{z0}) + m_3 \frac{C_{52} + C_{63}}{C_{22}} W_y r_{c3y3} + i r_{c3z3} m_3 \frac{C_{52} + C_{63}}{C_{33}} W_z + \\ & + \frac{A_0}{A_0 + A_3} \frac{C_{54} - C_{64}}{C_{44}} ((r_{z0} (m_0 + m_3) + m_3 r_{c3z3}) W_y + i (r_{y0} (m_0 + m_3) + \\ & + m_3 r_{c3y3}) W_z) + \frac{A_3 (\delta_\varphi + \delta_\psi)}{A_0 + A_3} ((r_{z0} (m_0 + m_3) r_{c3z3} m_3) W_y + i (r_{y0} (m_0 + \\ & + m_3) + r_{c3y3} m_3) W_z) + \left(-\frac{C_{13}}{2C_{22}} r_{c3y3} + \frac{C_{12}}{2C_{22}} r_{c3z3} - \frac{C_{23}}{C_{22}} \frac{C_{22}}{C_{22} - 4\dot{\gamma}^2 m_3} \times \right. \\ & \times r_{12x} - 2 \frac{C_{23}}{C_{22}} \frac{m_3 \dot{\gamma}^2 r_{c3x3}}{C_{22} - 4\dot{\gamma}^2 m_3} \left. \right) m_3 (W_y + iW_z) + 2 \frac{m_4^2 W_x}{C_{11}} \left(\frac{C_{22} - C_{11}}{C_{22}} W_y + \right. \\ & \left. + i \frac{C_{33} - C_{11}}{C_{22}} W_z \right) - (A_1 - B_1 + 3C_1 - A_2 + B_2 - 3C_2) \dot{\gamma} \Omega_0 + 2(2C_{60} + \\ & + (A_1 - B_1 - C_1) \dot{\gamma}^2 + ie_3 \dot{\gamma}) (\varphi_0 + V_0 K_{ny}^{-1} + U_\varphi) K_{Mn}^{-1} + \delta I, \end{aligned}$$

where δI is the component of the output signal for the sensor, dependent on the random variations of the parameters of the sensitive element and on the feedback circuit.

This mathematical model permits one to estimate the error of the angular-rate sensor upon exposure to different factors, and to formulate according to given conditions the requirements on the static and dynamic

unbalance of the rotor and center rings of the sensitive element, to the elastic-mass characteristics of the suspension of a tuned rotor gyroscope, and to the parameters of the feedback circuit.

BIBLIOGRAPHY

1. Brozgul, L. I. and Ye. L. Smirnov, "Vibratsionnyye giroskopy" [Vibratory Gyroscopes], Moscow, 1970.
2. Vlasov, Yu. B. and O. M. Filonov, "Rotornyye vibratsionnyye giroskopy v sistemakh navigatsii" [Rotary Vibratory Gyroscopes in Navigation Systems], Leningrad, 1980.
3. Pavlovskiy, M. A. and A. V. Zbrutskiy, "Dinamika rotornykh vibratsionnykh giroskopov" [The Dynamics of Rotary Vibratory Gyroscopes], Kiev, 1984.
4. "Measuring the Parameters of Angular Motions of the Base of a Tuned Rotor Gyroscope," IZVESTIYA VUZOV. PRIBOROSTROYENIYE, No 2, 1986.

UDC 531.768

ERROR OF COMPENSATION PENDULOUS ACCELEROMETER WITH FLEXIBLE SUSPENSION
DURING OPERATION UNDER SPATIAL VIBRATION CONDITIONS

907F0290G Kiev MEKHANIKA GIROSKOPICHESKIKH SISTEM in Russian, Issue 8,
1989 (manuscript received 10 Oct 87) pp 29-34

[Article by A. M. Ionin, engineer, and V. M. Slyusar, candidate of
technical sciences, Kiev Polytechnical Institute]

[Text] This article is devoted to description and study of the constant error component of a compensation pendulous accelerometer with flexible suspension (MKA s UP), operating under spatial vibration conditions. The problems similar to that postulated have until now been solved without refining the structure of the control circuit of the compensation pendulous accelerometer and the final result of the study was an expression that describes the constant error component of the MKA under two-component vibration conditions [1].

The purpose of this paper is to find expressions that permit one to estimate numerically the constant error component of the MKA and also to determine the requirements on the parameters of the accelerometer, fulfillment of which permits one to prevent the appearance of this constant component, i.e., to make the MKA invariant to spatial vibrations. Let us turn to the matrix form of writing the equations of motion of a MKA with flexible suspension:

$$(Mp^2 + C)q = -mQ(t) - u - R(t), \quad (1)$$

where M and C are matrices that characterized the inertial and elastic properties of the MKA, respectively, q is the column vector of the generalized coordinates, m is the mass of the movable part of the MKA, p is a differentiation operator, $Q = HW_{\Gamma}(t)$ is a matrix that characterizes the influence of the horizontal component of acceleration, acting along the axis of sensitivity, on the MKA, $u = U(p)q = DW(t)q$ is a matrix whose elements are determined by the action of the vertical and lateral components of acceleration ($W(t)^T = (0, W_B(t), W_D(t))$).

Assuming that all the elements of $R(t)$ are small, let us find the solution of (1) by the sequential approximation method. The equation of the first approximation is $(Mp^2 + C + U(p))q^{(1)} = -mHW_T(t)$. Its solution is

$$q^{(1)} = -mH(Mp^2 + C + U(p))^{-1} W_T(t). \quad (2)$$

The equation of the second approximation is $(Mp^2 + C + U(p))q^{(2)} = -DW(t)q^{(1)}$. The solution of this equation is

$$q^{(2)} = -DW(t)q^{(1)}(Mp^2 + C + U(p))^{-1}. \quad (3)$$

The desired constant error component of the MKA is

$$\langle \Delta u_{\text{MKA}} \rangle = \langle \Delta u^{(2)} \rangle = \langle U_0 q^{(2)} \rangle, \quad (4)$$

where $U_0 = U(0)$; $\langle \cdot \rangle = \frac{1}{T} \int_0^T (\cdot) dt$ is a time averaging operator and T is the time during which averaging occurs. Substituting (3) into (4), we find

$$\langle \Delta u_{\text{MKA}} \rangle = \langle -U_0 DW(t)q^{(1)}(C + U_0)^{-1} \rangle. \quad (5)$$

With regard to (2)

$$\langle \Delta u_{\text{MKA}} \rangle = \langle W_B(t) S_1(p) W_T(t) \rangle + \langle W_B(t) S_2(p) W_T(t) \rangle, \quad (6)$$

where $S_1 = U_0 D_1 mH(Mp^2 + C + U(p))^{-1} (C + U_0)^{-1}$; $S_2 = U_0 D_2 mH(Mp^2 + C + U(p))^{-1} (C + U_0)^{-1}$; $DW(t) = D_1 W_B(t) + D_2 W_B(t)$.

Expression (5) permits numerical estimation of the constant error component at known parameters of the MKA. It is obvious that the conditions of the invariance of the MKA to spatial vibrations have the form

$$S_1 = 0, \quad S_2 = 0. \quad (7)$$

To make the arguments more specific, let us introduce the generalized calculated model of a MKA with flexible suspension. Analysis of known layouts of compensation pendulous accelerometers shows that they can all be represented by a single block diagram (Figure 1).

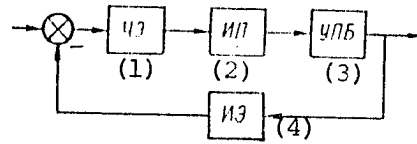

Figure 1

KEY:

- | | |
|------------------------|--------------------------------|
| 1. Sensitive element | 3. Amplifier-converting module |
| 2. Displacement sensor | 4. Actuating member |

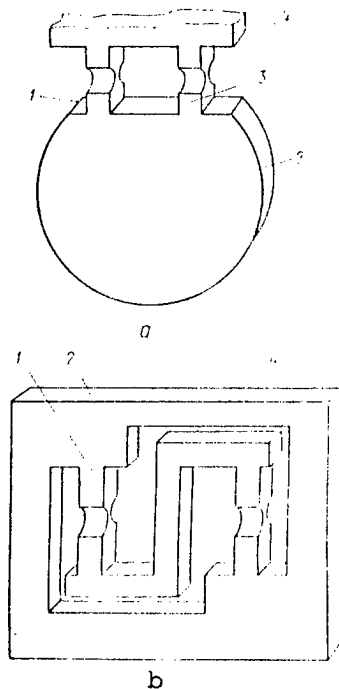

Figure 2

However, the control circuit may differ considerably in different accelerometers. Thus, a linear displacement converter (PLP) or angular displacement converter (PUP) can be used as a displacement sensor (IP), while a force converter or torque converter can be used as the actuating member (IE). The layouts of the flexible suspension (UP) may also be different. Let us consider two layouts when solving the problem: a

flexible suspension (Figure 2, a and b) whose flexible elements 1 and 3 connect the base 4 containing the sensitive element (ChE) of the accelerometer 2 by different methods.

Limiting ourselves to consideration of a MKA with two degrees of freedom (X is linear displacement along axis Ox , θ is the angular displacement with respect to axis Oy), let us write the equations of motion corresponding to (1) in a coordinate system whose center coincides with the center of stiffness of the flexible suspension:

$$\begin{aligned} (mp^2 + C_N)x + mLp^2\theta &= -mW_\Gamma(t) - k_{HC}u\gamma_1 - F_H(t), \\ mLp^2x + (I_0 + mL^2)p^2\theta &= -mLW_\Gamma(t) - k_{HC}u(\delta_Z\gamma_1 - \\ &\quad - \delta_{Z\Sigma}\gamma_2) - M_H(t). \end{aligned} \quad (8)$$

Here $u = k_{HHP}\Phi(p)(\beta_1(x + \sigma_Z\theta) + \beta_2\sigma_{Z\Sigma}\theta)$, where C_N and C_Y are the linear and angular stiffness of the flexible suspension, k_{HHP} , $k_{HHP}\sigma_{Z\Sigma}$, k_{HC} , $k_{HC}\delta_{Z\Sigma}$ are the amplification factors of the linear displacement converter, angular displacement converter, force converter (PS) and torque converter (PM), respectively, $I_0 + mL^2$ is the moment of inertia of the movable part of the MKA with respect to axis Oy , σ_Z and δ_Z are the distances to the axis of sensitivity of the linear displacement converter and to the effective axis of the force inverter, respectively, $\Phi(p)$ is the transfer function of the amplification inverting module, $F_H(t)$ and $M_H(t)$ are the force and moment caused by the influence of the spatial vibration of the MKA base on the stiffness of the flexible suspension, β_1 , β_2 , γ_1 , γ_2 , f_1 , f_2 are constant coefficients that take into account the values of 0 or 1 as a function of the composition of the control circuit (β_1 , β_2 , γ_1 , γ_2 , f_1 , f_2 are equal to 1 if the control circuit contains the PLP, PUP, PS, PM, and UP, respectively, shown in Figure 2, a, and the flexible suspension shown in Figure 2, b. Otherwise the values of the coefficients are equal to 0).

Let us rewrite equations (8) in the form

$$\begin{aligned} A(p)x + B(p)\theta &= -mW_\Gamma(t) - F_H(t), \\ C(p)x + D(p)\theta &= -mLW_\Gamma(t) - M_H(t), \end{aligned} \quad (9)$$

where

$$\begin{aligned}
A(p) &= mp^2 + C_{\text{л}} + k_{\text{пнп}}k_{\text{пс}}\Phi(p)\beta_1\gamma_1; \\
B(p) &= mLp^2 + k_{\text{пнп}}k_{\text{пс}}\Phi(p)\gamma_1(\beta_1\sigma_z + \beta_2\sigma_{z\text{з}}); \\
C(p) &= mLp^2 + k_{\text{пнп}}k_{\text{пс}}\Phi(p)\beta_1(\gamma_1\delta_z + \gamma_2\delta_{z\text{з}}); \\
D(p) &= (I_0 + mL^2)p^2 + C_{\text{y}} + k_{\text{пнп}}k_{\text{пс}}\Phi(p)(\beta_1\sigma_z + \beta_2\sigma_{z\text{з}})(\gamma_1\delta_z + \\
&\quad + \gamma_2\delta_{z\text{з}}).
\end{aligned} \tag{10}$$

According to notations (10), the expressions for S_1 and S_2 in formula (6) assume the form

$$\begin{aligned}
S_1 &= f_2 m b_{\text{в}} k_{\text{пнп}} \Phi_0 [\Delta_0 \Delta(p)]^{-1} \times [\alpha_1 a_{11} (\beta_2 \sigma_{z\text{з}} C_0 - \beta_1 \alpha_3) + \alpha_2 a_{22} \times \\
&\quad \times (\beta_1 \alpha_4 - \beta_2 \sigma_{z\text{з}} A_0)], \\
S_2 &= m^2 k_{\text{пнп}} \Phi_0 [\Delta_0 \Delta(p)]^{-1} [\alpha_1 (\beta_1 a_{12} \alpha_4 - \beta_1 f_1 a_{11} \alpha_3 + \beta_2 \sigma_{z\text{з}} (f_1 a_{11} C_0 - \\
&\quad A_0 a_{12})) + \alpha_2 (\beta_1 \alpha_4 (L + f_1 a_{22}) - \beta_1 \alpha_3 a_{12} - \beta_2 \sigma_{z\text{з}} (A_0 (f_1 a_{22} + L) - C_0 a_{12}))],
\end{aligned} \tag{11}$$

where $\alpha_1 = LB(p) - D(p)$; $\alpha_2 = C(p) - LA(p)$; $\alpha_3 = D_0 - C_0 \sigma_z$; $\alpha_4 =$
 $= B_0 - \sigma_z A_0$; $b_{\text{в}} = 2mLd^{-1}$.

Expressions (6) with regard to (11) link the constant error component of the output signal of the generalized model of the MKA, caused by the action of spatial vibration on the MKA, to the values of the vibration amplitude and parameters of the MKA.

Let us consider as an example two design layouts of a MKA with flexible suspension.

First layout. An accelerometer contains a sensitive element on a flexible suspension (Figure 2, a), linear displacement converter, amplification-converter module (UPB), and force inverter. Taking into account that $f_1 = \beta_1 = \gamma_1 = 1$, $f_2 = \beta_2 = \gamma_2 = 0$, for this accelerometer, we write

$$\begin{aligned}
S_1 &= 0, \\
S_2 &= m^2 k_{\text{пнп}} \Phi_0 [\Delta_0 \Delta(p)]^{-1} [(I_0 p^2 + C_{\text{y}}) (C_{\text{л}} \sigma_z a_{12} + C_{\text{y}} a_{11}) + \\
&\quad + C_{\text{л}} L (C_{\text{л}} \sigma_z (L + a_{22}) + C_{\text{y}} a_{12}) - \Phi(p) k_{\text{пнп}} k_{\text{пс}} (\delta_z - L) C_{\text{л}} \sigma_z (L + \\
&\quad + a_{22} - a_{12} \sigma_z) + C_{\text{y}} (a_{12} - a_{11} \sigma_z)].
\end{aligned} \tag{12}$$

Second layout. The flexible suspension corresponds to Figure 2, b, while the control circuit consists of an angular displacement converter,

amplification-converter module, and torque inverter. For this accelerometer, $f_1 = \beta_1 = \gamma_1 = 0$, $f_2 = \beta_2 = \gamma_2 = 1$. Then

$$\begin{aligned} S_1 &= mb_{\text{B}}k_{\text{ПДП}}\sigma_{z\Sigma}C_{\text{JL}}^2L\Phi_0a_{22}[\Delta_0\Delta(p)]^{-1}, \\ S_2 &= mb_{\text{B}}k_{\text{ПДП}}\sigma_{z\Sigma}\Phi_0C_{\text{JL}}[\Delta_0\Delta(p)]^{-1}[(I_0p^2 + C_{\text{Y}})a_{12} + C_{\text{JL}}L + \\ &\quad + k_{\text{ПДП}}k_{\text{ПЦ}}\Phi(p)\sigma_{z\Sigma}\delta_{z\Sigma}a_{12}]. \end{aligned} \quad (13)$$

Expressions (13) show that a MKA, designed by the second layout, can not be made invariant to spatial vibrations due to variation of the parameters. This possibility is essentially present for an accelerometer designed by the first layout. Indeed, expression $S_1 = 0$ means that the accelerometer will be invariant to lateral vibration at any values of its parameters. The condition of invariance of the MKA to vertical vibrations ($S_2 = 0$) reduces to imposition of additional requirements on the amplification factor of the amplification-converting module:

$$\begin{aligned} \Phi(p) &= [(I_0p^2 + C_{\text{Y}})(C_{\text{JL}}\sigma_{z\Sigma}a_{12} + C_{\text{Y}}a_{11}) + C_{\text{JL}}L(C_{\text{JL}}\sigma_{z\Sigma}(L + a_{22}) + \\ &\quad + C_{\text{Y}}a_{12})][k_{\text{ПЦ}}k_{\text{ПДП}}(\delta_z - L)(C_{\text{JL}}\sigma_{z\Sigma}(L + a_{22}) - a_{11}\sigma_{z\Sigma}) - C_{\text{Y}}(a_{11}\sigma_{z\Sigma} - a_{12})]. \end{aligned}$$

Calculations made for a constant flexible element with rectangular profile permit one to write with sufficient accuracy

$$\begin{aligned} \Phi(p) &\approx C_{\text{JL}}L[k_{\text{ПЦ}}k_{\text{ПДП}}(\delta_z - L)]^{-1} + I_0(C_{\text{JL}}\sigma_{z\Sigma}a_{12} + C_{\text{Y}}a_{11})p^2 \times \\ &\quad \times [k_{\text{ПЦ}}k_{\text{ПДП}}(\delta_z - L)C_{\text{JL}}L\sigma_{z\Sigma}]. \end{aligned}$$

The physical impracticality of the transfer function, described by expression (14), limits the practical application of the result. However, if the system is subjected to low-frequency perturbations, a static regulator with transfer factor $\Phi_0 = C_{\text{JL}}L[k_{\text{ПЦ}}k_{\text{ПДП}}(\delta_z - L)]^{-1}$ can be used in the control circuit to achieve invariance to spatial vibrations.

BIBLIOGRAPHY

1. Yevgenyev, V. S., "Resonant Vibrations of Pendulums With Regard to Elastic Pliancy of Pendulum Suspension Supports," "Vliyaniye vibratsiy, lineynykh uskoreniy i vrashcheniya osnovaniya na povedeniye giroskopicheskikh ustroystv" [The Influence of Vibrations, Linear Accelerations and Rotations of the Base on the Behavior of Gyroscopes], Tomsk, 1981.

UDC 531.516

ON CALCULATION OF TEMPERATURE FIELD IN FLOATED SUSPENSION

907F0290H Kiev MEKHANIKA GIROSKOPICHESKIKH SISTEM in Russian, Issue 8, 1989 (manuscript received 17 Oct 87) pp 34-38

[Article by A. S. Kireyev, candidate of technical sciences, and A. N. Mikhaylovskaya, junior scientific associate, Kiev Polytechnical Institute]

[Text] One of the main difficulties in study of the dynamics of thermomechanical systems of liquid bodies and solids is related to the infinity of the number of degrees of freedom of the liquid and to the nonlinearity of the equations of hydromechanics. It can be overcome with approximation of an infinite thermomechanical system by an idealized model with finite number of degrees of freedom. The most preferable way of designing a finite-dimensional model includes replacement of the differential equations in partial derivatives by a system of ordinary differential equations of the Galerkin type. This direction is based on expansion of the solution of the initial equations to a finite series with respect to some, rather representative system of coordinate functions, which corresponds to design of an infinite-dimensional phase space of solutions onto a finite-dimensional space.

For the temperature field

$$T(r, t) = \sum_{j=1}^n f_j(r) \omega^j(t), \quad r \in \Omega, \quad (1)$$

where f_j are functions of radius vector r , determined by their own projections in a suspension-bound coordinate system.

The temperature field $T(r, t)$ should satisfy the requirements of continuity at the interface of a solid and liquid body and the principle of minimum energy dispersion. Therefore, one can select the forms of f_j as solution of a linearized equation of thermal conductivity

$$\nabla^2 f_i(r) = 0, \quad r \in \Omega \quad (2)$$

at inhomogeneous boundary conditions $f_i(r) = \bar{f}_i^i(r)$, $i = \overline{1, m}$; $r \in \partial\Omega$ and of the linearized equation of thermal conductivity with respect to the natural forms of temperature distribution

$$\nabla^2 f_i(r) = \lambda_j f_i(r), \quad r \in \Omega \quad (3)$$

at homogeneous boundary conditions $f_i(r) = 0$, $i = \overline{m+1, n}$, $r \in \partial\Omega$, $j = \overline{1, \infty}$, where ∇^2 is a Laplace operator, λ_j is the eigen-value, and f_i are the forms of temperature distribution in region Ω .

As is known [1], the Laplace operator is negatively determined, i.e., its eigen-values are $\lambda_j < 0$, $j = \overline{1, \infty}$. This corresponds physically to averaging of the temperature through the region over time. We note that the longest are forms f_j , corresponding to the least eigen-values λ_j in absolute value. This is explained by the fact that the eigen-values λ_j determine the attenuation decrement of the corresponding form f_j due to the diffuse nature of the process of thermal conductivity.

The first group of expansion coefficients (1) ω^j , $j = \overline{1, m}$, corresponding to the forms of temperature distribution with inhomogeneous boundary conditions and given in the form of a time function, is the input effects of the thermomechanical model. The second group of coefficients ω^j , $j = \overline{m+1, n}$, corresponding to the natural forms of temperature distribution with homogeneous boundary conditions, determines the variable states of the model.

The region of liquid flow Ω is generally complex in shape, and, therefore, the linear boundary-value problems (2) and (3) can be solved only by using numerical methods. The finite element method, the main idea of which includes approximation of the continuous value by a discrete model, is the most convenient. This model is constructed on a set of piecewise continuous functions, determined on a finite number of

elements [2] $\Omega = \bigcup_{e=1}^E \Omega_e$, where E is the total number of finite elements

The region Ω occupied by the liquid can be divided into eight-nodal finite elements for a broad range of devices with floated spherical suspension of the sensitive element.

Solution of problems (2) and (3) on each element is represented in the form of the expansion $f^e = [N]^e \{f\}^e$, where $[N]^e = [N_1 N_2 \dots N_s]$ is a matrix of the linear functions of the shape of the element and $\{f\}^e = \{f_1/f_2/f_3 \dots f_s\}$ is the column vector of the values of $\{f\}^e$ in the approximation nodes.

Functions of form N_β can be written as follows: $N_\beta = 0,125(1 + \xi\xi_\beta)(1 + \eta\eta_\beta)(1 + \zeta\zeta_\beta)$, $\beta = \overline{1,8}$ in the natural coordinate system $(-1 \leq \xi, \eta, \zeta \leq 1)$.

Using the Galerkin method, let us find the approximate solution of differential equations (2) and (3). To do this, let us satisfy the condition: the difference between the approximate and accurate solutions should be orthogonal to the functions used in approximation. Minimizing the discrepancy of the approximate solution by the basic function in region Ω_e , let us write for expressions (2) and (3), respectively

$$\int_{\Omega_e} [N]^e \nabla^2 [N]^e d\Omega_e \{f\}_i^e = 0, \quad i = \overline{1, m}; \quad (4)$$

$$\int_{\Omega_e} [N]^e \nabla^2 [N]^e d\Omega_e \{f\}_i^e = \lambda_j \int_{\Omega_e} [N]^e [N]^e d\Omega_e \{f\}_j^e, \quad (5)$$

$$i = \overline{m+1, n}; \quad j = \overline{1, n-m}.$$

Using integration by parts, let us reduce the order of the derivative in (4) and (5) and let us find a series of systems of linear algebraic equations with respect to the unknown values of the forms of temperature $\{f\}_i$, $i = \overline{1, m}$ in the approximation nodes

$$[A] \{f\}_i = 0, \quad i = \overline{1, m}, \quad (6)$$

and also the generalized problem for eigen-values

$$[A] \{f\}_i = \lambda_j [B] \{f\}_j, \quad i = \overline{m+1, n}, \quad j = \overline{1, n-m}. \quad (7)$$

Here $[A] = \bigcup_{e=1}^E [A]^e$; $[B] = \bigcup_{e=1}^E [B]^e$ are quadratic matrices of problems of

linear algebra (6) and (7) whose dimension is equal to the number of approximation nodes N , where

$$[A]^e = \int_{\Omega_e} \left(\frac{\partial [N]^e}{\partial \rho} \frac{\partial [N]^e}{\partial \rho} + \frac{1}{\rho^2} \frac{\partial [N]^e}{\partial \theta} \frac{\partial [N]^e}{\partial \theta} + \right. \\ \left. + \frac{1}{\rho^2 \sin^2 \theta} \frac{\partial [N]^e}{\partial \varphi} \frac{\partial [N]^e}{\partial \varphi} \right) d\Omega_e - \int_{\partial \Omega_e} [N]^e \frac{\partial f}{\partial n} d\Omega_e;$$

$[B]^e = \int_{\Omega_e} [N]^e [N]^e d\Omega_e$ are the quadratic matrices of the finite element of

dimension 8 and ρ , θ , and φ are the spherical coordinates of the approximation nodes.

The resulting matrices $[A]$ and $[B]$ are positive-determinate, sparsely filled and symmetrical with respect to the main diagonal. The first property permits one to use iterative methods of solution.

The upper relaxation method, which permits one to operate only with nonzero coefficients of a densely packed [3] matrix $[A]$, can be used to solve the system of linear algebraic equations (6).

The value of the j -th variable on the $k + 1$ -th iteration is determined by the formula

$$f_j^{k+1} = f_j^k + qa_{jj}^{-1} \left(\sum_{s=1}^{j-1} a_{js} f_s^{k+1} - \sum_{s=j}^N a_{js} f_s^k \right),$$

where q is a relaxation parameter.

The criterion of the end of the iteration process is $\max_j |f_j^{k+1} - f_j^k| \leq \epsilon$, $k \leq I_1$, $j = \overline{1, N}$, where ϵ is the accuracy of calculating the form and I_1 is the maximum number of iterations in solution of the system of linear algebraic equations.

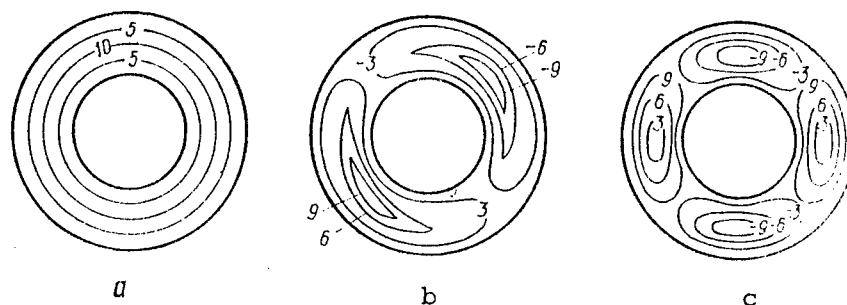

Let us solve problem (7) by the power method [4, 5]. Let us assume that $\mu_j = \lambda^{-1}_j$, and then

$$[B] \{f\}_j = \mu_j [A] \{f\}_j. \quad (8)$$

Thus, determination of the minimal eigen-value of problem (7) is identical to determination of the maximum eigen-value for problem (8).

Let us construct two sequences of vectors $\{X\}_k$ and $\{Y\}_k$ such that

$$\{Y\}_k = [B] \{X\}_{k-1}, [A] \{X\}_k = \{Y\}_k, \quad k = \overline{1, \infty}. \quad (9)$$

The sequence $\{X\}_k$ reduces [4] to the eigen-vector $\{f\}_1$, corresponding to the maximum value μ_1 of problem (8). Let us find the approximations to the eigen-value from the Rayleigh relation

$$\mu^k = (\{Y\}_{k+1}, \{X\}_k) (\{Y\}_k, \{X\}_k)^{-1}, \quad k = \overline{1, \infty}.$$

Let us formulate the criterion of the end of the iteration process in $(\mu^{k+1} - \mu^k) (\mu^k)^{-1} \leq \delta$, $k = \overline{1, I_2}$, where δ is a previously given small number and I_2 is a number that restricts the number of iterations.

The eigen-vectors, corresponding to the higher eigen-values of λ_i , $i = \overline{2, n - m}$, are determined by the above algorithm with regard to their orthogonality to each of the previous eigen-vectors $\{f\}_j$, $j = \overline{1, i - 1}$. Let us assume for this at each k -th iteration of process (9) for the i -th eigen-vector

$$\{X\}_k = \{X\}_k - \sum_{j=1}^{i-1} a_j \{f\}_j,$$

where the unknown constants a_j are calculated by the formula

$$a_j = (X)_n, [B]\{f\}_j (\{f\}_j, [B]\{f\}_j)^{-1}, j = \overline{1, i-1}.$$

The first three eigen-forms in the cylindrical region (Figure a, b, and c, respectively) were calculated to check the constructed algorithm for calculating the forms of temperature distribution with homogeneous boundary conditions. The difference of the results of calculations from the analytical estimates from [1] does not exceed 5 percent.

The developed algorithm for calculating the forms of temperature distribution permits one to construct effective mathematical models of the dynamics of semi-aggregate thermomechanical systems.

BIBLIOGRAPHY

1. Marchuk, G. I., "Metody vychislitelnoy matematiki" [Methods of Computer Mathematics], Moscow, 1980.
2. Segerlund, L., "Primeneniye metoda konechnykh elementov" [Application of the Finite Element Method], Moscow, 1979.
3. Kureyev, A. S., "Solution of the Stationary Stokes Problem in a Quasi-Spherical Thin Layer Using the Finite Element Method," Kiev, 1984., deposited at UkrNIINTI on 26 Nov 84, No 1940 Uk-84 Dep.
4. Fadeyev, D. K. and V. N. Fadeyeva, "Vychislitelnyye metody lineynoy algebrы" [Computer Methods of Linear Algebra], Moscow, 1963.
5. Radysh, Yu. V., A. S. Kireyev, and O. P. Marosin, "Determination of the Forms of Liquid Flow in a Floated Suspension," MEKHANIKA GIROSKOPICHESKIKH SISTEM, No 5, 1986.

UDC 531.313:532.58

STUDY OF ROTATION OF SOLID IN FLOATED SUSPENSION

907F0290I Kiev MEKHANIKA GIROSKOPICHESKIKH SISTEM in Russian, Issue 8, 1989 (manuscript received 17 Oct 87) pp 38-43

[Article by A. S. Kireyev, candidate of technical sciences, Yu. V. Radysh, candidate of physicomathematical sciences, and A. I. Yurokin, candidate of physicomathematical sciences, Kiev Polytechnical Institute]

[Text] A floated suspension (Figure 1) is a supported solid (float), immersed in a liquid and included together with it in the spherical cavity of a bearing solid (body). The region occupied by the liquid between the surface of the float and the surface of the body cavity Γ_2 is multiply connected and branched. Let us link to the float a closed surface Γ_1 , which separates the considered region into two subsystems: the float and liquid in region Ω_1 with boundary Γ_1 and the liquid in single-connected region Ω_2 with boundary $\Gamma_1 \cup \Gamma_2$. Surface Γ_1 consists of connectors in the liquid and in part of the surface of the solid.

The purpose of the paper is to construct a mathematical model of the rotational motion of the float about a fixed point upon given rotation of the body and with a partially given field of the relative flow rate of the liquid on the connections, belonging to surface Γ_1 .

Let us link the frame of reference and the coordinate system to the float. In this case, the rotation of the float will be transport [translator's note: several words illegible] of body Γ_2 and the flow region of the liquid will not vary over time.

The complexity of studying the dynamics of mechanical systems that contain solids, interacting with a viscous liquid, is related to the infinity of the number of degrees of freedom of the liquid in combination with the nonlinearity of the equations of hydromechanics. The flow nature assumes the motion of the liquid with considerable Reynolds numbers, which eliminates the possibility of using linearized equations. One of the methods of solving the problem is to approximate the real infinite-dimensional system by a model with restricted number of degrees of freedom, which reflects the significant aspects of the dynamics of this system [1, 2].

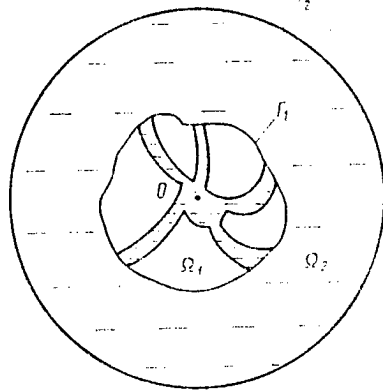

Figure 1

Let us assume the velocities of the mechanical system as linear combinations of the limited number of forms $f_i(r)$, $q_i(r)$ ($i = \overline{1, n}$) of the possible velocity distributions of the float and liquid in region Ω_2 as the basis of kinematic concepts. These forms can be established from solution of auxiliary boundary-value problems [3]. The speed of the liquid in subsystem 1 is $V_1(r, t) = f_i(r) \times \varepsilon^i(t)$ ($r \in \Omega_1 \cup \Gamma_1$) and that in subsystem 2 is $V_2(r, t) = q_i(r) \omega^i(t)$ ($r \in \Omega_2 \cup \Gamma_1 \cup \Gamma_2$). Here ε^i, ω^i ($i = \overline{1, n}$) are the quasi-speeds of subsystems 1 and 2, respectively. Let ε^i, ω^i ($i = \overline{1, 3}$) be the components of the angular rotational velocity vector of the float, ω^i ($i = \overline{4, 6}$) be the components of the vector of the angular velocity of the body, let ε^i, ω^i ($i = \overline{7, 9}$) be the components of the vector of the flow rate of the liquid through the connectors of surface Γ_1 , which determine the transport of the moment of momentum from region Ω_1 to region Ω_2 , and let ε^i, ω^i ($i = \overline{10, n}$) be the quasi-speeds that correspond to forms of motion of the liquid, generated by different boundary conditions in a fixed coordinate system, bound to the float. The quasi-speeds ω^i ($i = \overline{1, 3, m+1, n}$), which are variables of state of the model, must be determined, while quasi-speeds ω_i ($i = \overline{4, m}$), given in the form of time functions, are input actions.

Systems of ordinary differential equations

$$g_{ij} \dot{\varepsilon}^j + \Gamma_{im} \varepsilon^j \dot{\varepsilon}^k = \dot{p}_i \quad (1)$$

$$g_{ij}\dot{\omega}^j + a_{ij}\omega^j + \Gamma_{ijk}^2\omega^j\omega^k = \dot{P}_i \quad (i, j, k = \overline{1, n}) \quad (2)$$

describe the motion of the float and liquid, respectively [4, 5]. The components of the positive definite numerical tensors of second rank of kinetic energy in regions Ω_1 and Ω_2 are determined with regard to the rotating frame of reference by the expressions

$$g_{ij}^1 = \int_{\Omega_1} \mathbf{f}_i \mathbf{f}_j d\rho \Omega \quad (i = \overline{1, 3}, j = \overline{4, n}), \quad (3)$$

$$g_{ij}^2 = \int_{\Omega_2} \varphi_i \varphi_j d\rho \Omega \quad (i, j = \overline{1, n}).$$

Here ρ is density.

The components of the positive definite numerical tensor of second rank of the dissipative function of the liquid in region Ω_2 with regard to a rotating frame of reference have the form

$$a_{ij}^2 = 2 \int_{\Omega_2} \Delta^c \varphi_i : \nabla^c \varphi_j d\rho \nu \Omega \quad (i, j = \overline{1, n}). \quad (4)$$

Here ν is the kinematic viscosity of the liquid.

The components of the tensor of third rank of dynamic connectedness between different forms of motion of the float and liquid are determined with regard to a rotating frame of reference by the expressions

$$\Gamma_{ijk}^1 = 0,5 \int_{\Omega_1} (\mathbf{f}_j \nabla \mathbf{f}_k + \mathbf{f}_k \nabla \mathbf{f}_j) \mathbf{f}_i d\rho \Omega \quad (i = \overline{1, 3}; j, k = \overline{1, 3}, \overline{4, n}); \quad (5)$$

$$\Gamma_{ijn}^1 = \Gamma_{ijn}^2 = \int_{\Omega_1} \mathbf{f}_j \nabla \mathbf{f}_k \mathbf{f}_i d\rho \Omega \quad (i = \overline{1, 3}; j = \overline{4, n}; k = \overline{1, 3}). \quad (6)$$

Coefficients Γ_{ijk}^2 ($i, j, k = \overline{1, n}$) are determined by expressions (5) and (6) after substitution of indices 1 by 2 and of forms \mathbf{f} by φ .

In equations (1) and (2), $\overset{1}{P}_i$ and $\overset{2}{P}_i$ are generalized forces corresponding to ϵ^i and ω^i , respectively, and applied to the liquid.

Let us exclude surface (contact) hydrodynamic forces, adding equations (1) and (2) with indices $i = \overline{1, 3}$ and subtracting equations (2) with indices $i = \overline{4, 6}$. Disregarding the variation of the moment of momentum of the liquid in relative motion through the float $\overset{1}{g}_{ij}\dot{\epsilon}^j = 0$ ($i = \overline{1, 3}$, $j = \overline{4, n}$) and the principal moment of Coriolis forces of inertia acting on the rotating float from the direction of the liquid $2\overset{1}{\Gamma}_{ijh}\epsilon^j\dot{\epsilon}^k = 0$ ($i = \overline{1, 3}$), passing through it, we find the equations of rotational motion of the float only with respect to quasi-speeds ω

$$\sum_{j=1}^3 \left[(\overset{0}{g}_{ij} + \overset{1}{g}_{ij}) \dot{\omega}^j + \sum_{k=1}^3 (\overset{0}{\Gamma}_{ijh} + \overset{1}{\Gamma}_{ijh}) \omega^j \omega^k \right] + \sum_{j=4}^n \left[\overset{0}{g}_{ij} \dot{\omega}^j + \overset{0}{a}_{ij} \omega^j + \right. \quad (7)$$

$$\left. + \sum_{k=4}^n \overset{0}{\Gamma}_{ijh} \omega^j \omega^k \right] + 2 \sum_{j=4}^n \sum_{k=1}^3 \overset{0}{\Gamma}_{ijh} \omega^j \omega^k = 0 \quad (i = \overline{1, 3}),$$

where $\overset{0}{g}_{ij} = \overset{2}{g}_{ij} - \overset{2}{g}_{i+3,j}$; $\overset{0}{a}_{ij} = -\overset{2}{a}_{ij}$; $\overset{0}{\Gamma}_{ijh} = \overset{2}{\Gamma}_{ijh} - \overset{2}{\Gamma}_{i+3,jh}$.

The dynamic model (2) and (7) is closed with respect to variable states ω^i ($i = \overline{1, 3, m+1, n}$) if the input actions ω^i ($i = \overline{4, m}$) are known given time functions.

The vector of the relative angular velocity of the body in a rotating coordinate system, bound to the float, can be expressed by the vector of the absolute angular rotational velocity of the body in a fixed coordinate system ω_a^j ($j = \overline{4, 6}$):

$$\omega^{i+3} = c_j^i \omega_a^j - \omega^i \quad (i = \overline{1, 3}), \quad (8)$$

where $[c^i_j]$ is a matrix of orthonormal transformation of a fixed coordinate system to a movable coordinate system. Differentiating expression (6), we find the components of the vector of the relative angular acceleration in a rotating coordinate system

$$\dot{\omega}^{i+3} = -e_{kj}^i \omega^j \dot{\omega}_a^k + c_j^i \dot{\omega}_a^{j+3} - \dot{\omega}^j \quad (i, j, k = \overline{1, 3}), \quad (9)$$

where e^i_{kj} are Levy-Chivit symbols.

The dynamic equations of state in quasi-speeds (2) and (7) are supplemented by three kinematic equations of rotation of the body about a fixed point with respect to Euler angles when expressions (8) and (9) are used [6]. Matrix $[c^i_j]$ is fully determined by the values of the Euler angles, which are independent parameters of orthogonal transformation.

The structure of system of equations (2) and (7) was studied by method [5] for $n = 22$ forms of liquid flow with regard to the structural symmetry of region Ω_2 . Analysis showed that the tensor of inertia (3) is restored from 18 independent coefficients and dissipation tensor (4) is restored from 96 independent coefficients, calculated by the above expressions. The time of calculating functionals (3)-(5) on a computer is reduced by more than an order of magnitude.

For numerical integration of system (2) and (7), it must be solved with respect to the arbitrary unknown quasi-speeds. Matrix $[\hat{g}_{ij}]$ must be inverted for this:

$$\hat{g}_{ij} = \begin{cases} g_{ij} + g_{ij} - g_{i+3,j} - g_{i,j+3} + g_{i+3,j+3} & (i, j = \overline{1,3}), \\ g_{ij} - g_{i+3,j} & (i = \overline{1,3}, j = \overline{m+1,n}), \\ g_{ij} - g_{i,j+3} & (i = \overline{m+1,n}, j = \overline{1,3}), \\ g_{ij} & (i, j = \overline{m+1,n}). \end{cases}$$

Theoretical analysis showed that $[\hat{g}_{ij}]$ is a nondegenerate positive definite symmetrical matrix. It turned out in study of the real values of coefficients $[g_{ij}]$ that the largest coefficients are located on the main diagonal of the matrix. The difference of the diagonal coefficients by five-six orders upon direct inversion of this poorly determined matrix $[g_{ij}]$ results in violation of the properties of symmetry and of positive definiteness to such an extent that numerical integration becomes unstable, while its results are uncertain. To avoid this, the inversion is made in three steps.

1. Transition from matrix $[\hat{g}_{ij}]$ to matrix $[g^*_{ij}]$ is:

$$g^*_{ij} = T_{ij} \hat{g}_{ij} T_{ij} \quad (10)$$

the order of the diagonal elements of which is identical. In expression (10) $T_{ij} = \delta_{ij} / \sqrt{g^*_{ij}}$ ($i, j = \overline{1,3}; \overline{m+1,n}$), where δ_{ij} is a Kronecker symbol.

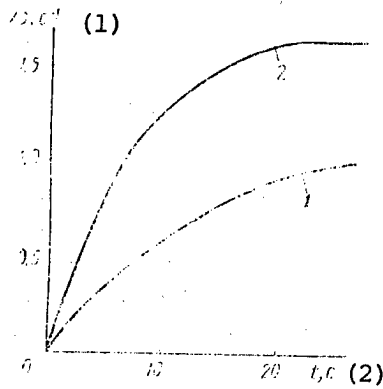

Figure 2

KEY:

1. s^{-1}

2. s

This transformation guarantees conservation of symmetry, positive definiteness, and also equality of the elements of the main diagonal to unity.

2. Inversion of matrix $[g_{ij}^*]$ by the numerical method of orthogonalization [7].

3. Determination of matrix $[\hat{g}_{ij}]^{-1}$ by the formulas

$$\hat{g}_{ij}^{-1} = T_{ij} g_{ij}^{*-1} T_{ij} \quad (11)$$

One can ascertain the validity of relation (11) by a direct check. One can derive from (11) the equality $\hat{g}_{ij} = T_{ij}^{-1} g_{ij}^* T_{ij}^{-1}$, and having multiplied both the left and right sides of which by T, we find expression (10).

The results of numerical simulation of the angular rotational speed of the float, which had cubic symmetry, at constant angular velocity of the body

$$\omega_i(t) = 1 \text{ s}^{-1} \quad (i = 4) \quad (12)$$

and zero initial conditions, are presented in Figure 2. Upon rotation of the body, the liquid in region Ω_2 is gradually set into rotation, drawing the float after it, the angular velocity of which emerges to steady value 1 s^{-1} (curve 1). A similar pattern is observed (curve 2)

upon assignment by law (12) with $i = 7$ of a constant flow rate of the liquid through the connectors of the float, which determines the transport of the moment of momentum through surface Γ_1 .

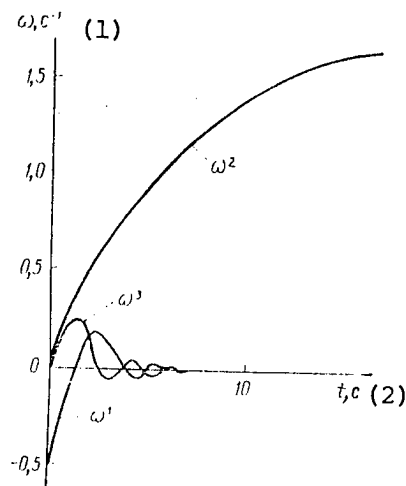

Figure 3

KEY:

1. s^{-1}

2. s

If the vector of transport of the moment of momentum of the liquid through surface Γ_1 is not colinear to the vector of the initial angular velocity of the float, the results of calculations indicate the presence of a gyroscopic effect during the transition period (Figure 3).

Calculations made upon approximation of region Ω_2 by 1,140 eight-node spatial end elements (1,800 nodes), occupy 700 kbytes of the main memory of the computer and require 2.5 hr on the YeS-1060 computer.

The model permits numerical study of the dynamics of a floated suspension on the computer and optimization of it by the given figures of merit.

BIBLIOGRAPHY

1. Gledzer, Ye. B., F. V. Dolzhanskiy, and A. I. Obukhov, "Nelineynyye sistemy gidrodinamicheskogo tipa" [Nonlinear Hydrodynamic Systems], Moscow, 1974.
2. Ladyzhenskaya, O. A., "Matematicheskiye voprosy dinamiki vyazkoy neszhimayemoy zhidkosti" [Mathematical Problems of the Dynamics of a Viscous Incompressible Liquid], Moscow, 1970.

3. Radysh, Yu. V., A. S. Kireyev, and O. P. Marosin, "Determining the Forms of Liquid Flow in a Floated Suspension," MEKHANIKA GIROSKOPICHESKIKH SISTEM, No 5, 1986.
4. Radysh, Yu. V., "On Some Forms of Equations of Motion of Mechanical Systems Containing a Liquid," VESTNIK KIEVSKOGO POLITEKHNICHESKOGO INSTITUTA. PRIBOROSTROYENIYE, No 11, 1981.
5. Radysh, Yu. V. and A. I. Yurokin, "Consideration of the Symmetries of a System of Liquids and Solids in the Structure of Dynamic Equations," MEKHANIKA GIROSKOPICHESKIKH SISTEM, No 5, 1986.
6. Lurye, L. G., "Analiticheskaya mekhanika" [Analytical Mechanics], Moscow, 1961.
7. Fadeyev, D. K. and V. N. Fadeyeva, "Vychislitelnyye metody lineynoy algebrы" [Computer Methods of Linear Algebra], Moscow, 1963.

UDC 621.391

USING REDUNDANT INFORMATION TO ESTIMATE ERRORS OF MEASURING ANGULAR VELOCITY TRANSDUCERS

907F0290J Kiev MEKHANIKA GIROSKOPICHESKIKH SISTEM in Russian, Issue 8, 1989 (manuscript received 15 Sep 87) pp 44-47

[Article by A. A. Leonets, candidate of technical sciences, Kiev Polytechnical Institute]

[Text] One of the promising directions of improving the accuracy of information measuring systems is compensation of the errors of measuring transducers (IP) by special processing of their signals. If the parameters of measuring transducers are unstable, a necessary condition of the effectiveness of this method is estimation of the errors of the measuring transducers during functioning of them. The principal capability of using bending oscillations of the body of an object to estimate the drift of measuring transducers is shown in [1].

Expressions that permit one to estimate the multiplicative and additive errors of measuring angular velocity transducers during functioning of a redundant measuring system, mounted on a rigid base, are found in this article.

Postulation of problem. Let us assume that two measuring systems, consisting of three one-degree accelerometers and three one-degree measuring angular velocity transducers, are mounted on a rigid movable base. This type of system is described, for example in [2]. Let us denote the parameters of the systems by subscripts 1 and 2. The axes of sensitivity of measuring angular velocity transducers and accelerometers of the first and second systems form orthogonal coordinate systems O_1xyz and O_2oxy , the unit vectors of which are mutually colinear. The position of point O_2 in coordinate system O_1xyz is determined by radius vector $R = (R_x, 0, 0)^T$. Expressions must be found that permit one to estimate the additive and multiplicative errors of a measuring angular velocity transducer by the output signals of the measuring transducer.

To do this, let us present the output signals of the accelerometers $a^*_1(k)$ and $a^*_2(k)$ and of the measuring angular velocity transducers $\omega^*_1(k)$ and $\omega^*_2(k)$ at k -th moment of time in the form

$$a^*_1(k) = (E + \Delta K_{a_1})a(k) + \Delta a_1 + \xi_{a_1}(k); \quad (1)$$

$$a^*_2(k) = (E + \Delta K_{a_2})(a(k) + \omega(k) \times (\omega(k) \times R) + \epsilon \times R) + \Delta a_2(k) + \xi_{a_2}(k); \quad (2)$$

$$\begin{aligned} \omega^*_1(k) &= (E + \Delta K_{\omega_1})\omega(k) + \Delta \omega_1 + \xi_{\omega_1}(k); \\ \omega^*_2(k) &= (E + \Delta K_{\omega_2})\omega(k) + \Delta \omega_2 + \xi_{\omega_2}(k), \end{aligned} \quad (3)$$

where E is a unit matrix;

$$\Delta K_{ij} = \begin{vmatrix} (\Delta K_{ij})_x & 0 & 0 \\ 0 & (\Delta K_{ij})_y & 0 \\ 0 & 0 & (\Delta K_{ij})_z \end{vmatrix}, \quad i = a, \omega; \quad j = 1, 2$$

are matrices of the errors of scale coefficients of the measuring transducer, $a = (a_x, a_y, a_z)^T$; $\omega = (\omega_x, \omega_y, \omega_z)^T$ are vectors of linear acceleration and of the angular speed of the base, ϵ is the angular acceleration of the speed of the base, and $\Delta a_i = \text{const}$ and $\Delta \omega_i = \text{const}$, $i = 1, 2$ are vectors of displacements of the zeros of accelerometers and drift of the measuring angular velocity transducer.

Disregarding second-order values, one can find the angular speed of the base from expression (3) in the form $\omega(k) = (E - \Delta K_{a_1})(\omega^*_1(k) - \Delta \omega_1 - \xi_{\omega_1}(k))$. Subtracting equation (1) from (2) and substituting the value $\omega(k)$, after transformations, we find

$$Y(k) = H(k)X(k) + B(k)\xi(k), \quad (4)$$

where

$$\begin{aligned}
Y(k) &= a_2^*(k) - a_1^*(k) - \omega_1^* \times (\omega_1^* \times R) - \varepsilon_1^* \times R; \\
H &= |H_\omega | H_{\Delta K_\omega} + H_\varepsilon | H_{\Delta K_{a_2}} | H_{\Delta K_{a_1}} | E |; \quad B = |H_\omega | H_\varepsilon | E |; \\
H_\omega &= \begin{vmatrix} 0 & 2\omega_y^* R_x & 2\omega_z^* R_x \\ -R_x \omega_y^* & -R_x \omega_x^* & 0 \\ -R_x \omega_z^* & 0 & -R_x \omega_x^* \end{vmatrix}; \\
H_{\Delta K_\omega} &= \begin{vmatrix} 0 & 2\omega_y^{*2} R_x & 2\omega_z^{*2} R_x \\ -\omega_x^* \omega_y^* R_x & -\omega_x^* \omega_y^* R_x & 0 \\ -\omega_x^* \omega_z^* R_x & 0 & -\omega_x^* \omega_z^* R_x \end{vmatrix}; \\
H_\varepsilon &= \begin{vmatrix} 0 & 0 & 0 \\ 0 & 0 & -\varepsilon_{z_1}^* R_x \\ 0 & \varepsilon_{y_1}^* R_x & 0 \end{vmatrix}; \quad H_{\Delta K_{a_1}} = \begin{vmatrix} a_{x_1}^* & 0 & 0 \\ 0 & a_{y_1}^* & 0 \\ 0 & 0 & a_{z_1}^* \end{vmatrix}; \\
H_{\Delta K_{a_2}} &= \begin{vmatrix} a_{x_1}^* - (\omega_{y_1}^{*2} + \omega_{z_1}^{*2}) R_x & 0 & 0 \\ 0 & a_{y_1}^* + \omega_{x_1}^* \omega_{y_1}^* R_x & 0 \\ 0 & 0 & a_{z_1}^* + \omega_{x_1}^* \omega_{z_1}^* R_x \end{vmatrix}; \\
X &= |\Delta\omega_{x_1} | \Delta K_\omega | \Delta K_{a_2} | \Delta K_{a_1} | \Delta a_2 - \Delta a_1 |^T; \\
\xi &= |\xi_\omega | \dot{\xi}_\omega | \eta_{a_2} - \eta_{a_1} |^T.
\end{aligned}$$

Let us supplement equation (4) with a mathematical model of the vector of the desired parameters X, ordinarily determined during experimental studies of measuring transducers:

$$X(k) = \Phi(k|k-1)X(k-1) + \vartheta(k), \quad (5)$$

where $\Phi(k|k-1)$ is the transient matrix of dimension 15×15 and $\vartheta(k)$ is white noise of intensity Q.

Expressions (4) and (5) permit one to estimate the values of vector X, for example, using a Kalman filter: $\hat{X}(k|k) = \hat{X}(k|k-1) + K(k)[Y(k) - H\hat{X}(k|k-1)]$. Here $\hat{X}(k|k)$ is an estimate of vector X(k) at k-th moment of time, $\hat{X}(k|k-1)$ is the predicted value of X(k) from the results of measurements on time interval [1, k-1], and K(k) is the amplification factor of the filter.

When realizing the Kalman filter to guarantee the convergence of estimates to the value of vector $X(k)$, it is necessary that the rank of the matrix of observability $M[0, k]$ be equal to the dimensionality of the estimated vector ($m = 15$ in the given case):

$$M[k, 0] = [\Phi^T(k|0)H^T(0), \Phi^T(k|1)H^T(1), \dots, \Phi^T(k|k-1)H^T(k-1), \\ H^T(k)] [H(0)\Phi(k|0), H(1)\Phi(k|1), \dots, \Phi(k|k-1)H(k-1), H(k)]. \quad (6)$$

Analysis of expressions (5) and (6) shows that the components of vector X are observable through at least five measurement cycles at $\Phi(i|i-1) = \text{const}$, $\omega(i) \neq \omega(j) \neq 0$; $a(i) \neq a(j) \neq 0$; $i, j = 1, \overline{5}$; $i \neq j$.

Taking into account that the additive and low-frequency multiplicative error components of the measuring transducer during a measurement cycle are considerably less than the high-frequency components, observation data $Y(k)$ can first be accumulated to increase the ratio of useful signal/noise and to reduce the load of the computer upon realization of the Kalman filter. The elements of $H(k)$, contained in the expression for determination of vector $Y(k)$, are ordinarily periodic in nature and the positive values are compensated by negative values upon summation of them at different moments of time. Therefore, the signs of the measurement results should be taken into account to increase the signal/noise ratio upon summation.

The process of accumulation must be divided into four cyclically repeatable steps to guarantee uniform convergence of the estimates of all the components of vector X to the true values. The group of elements of vector X is set into agreement to each step and is added with regard to the signs of the elements of matrix $H(k)$ so that there is rapid convergence of estimates of the corresponding group of components of vector X . Assuming that $X(k) = X(k-1)$, the vector of observations in this case is determined from the relation

$$Y^*(j) = \sum_{i=jn+1}^{(j+1)n} W_j(i) Y(i) = \left(\sum_{i=jn+1}^{(j+1)n} W_j(i) H(i) \right) X + \\ + \sum_{i=jn+1}^{(j+1)n} W_j(i) B(i) \xi(i), \quad (7)$$

where n is the number of observations accumulated on one step, and

$$W_1(i) = \text{diag}(\text{sign } \omega_{x_1}^*, \text{sign } \omega_{y_1}^*, \text{sign } \omega_{z_1}^*); W_2(i) = \text{diag}(1, \text{sign}(\omega_{x_1}^* \omega_{y_1}^*), \text{sign}(\omega_{z_1}^* \omega_{x_1}^*)); W_3(i) = \\ = \text{diag}(\text{sign } a_{x_1}^*, \text{sign } a_{y_1}^*, \text{sign } a_{z_1}^*); W_4(i) = E.$$

Expressions (7) and (6) permit one to estimate and compensate for the errors of the scale coefficients and drift of the measuring angular velocity transducers and accelerometers and thus to increase the accuracy of the measuring system.

BIBLIOGRAPHY

1. Leonets, A. A., "Estimating the Drift of Measuring Transducers Mounted on a Flexible Base," MEKHANIKA GIROSKOPICHESKIKH SISTEM, No 7, 1988.
2. Ebner, R. E., "Integrated Inertial Sensor Assembly Problem Status," IEEE POSITION LOCATION AND NAVIGATION, New York, 1984.

UDC 621.391:531.383

BAYES APPROACH TO PROBLEMS OF ESTIMATING STATE OF ROTARY SYSTEMS

907F0290K Kiev MEKHANIKA GIROSKOPICHESKIKH SISTEM in Russian, Issue 8, 1989 (manuscript received 9 Sep 86) pp 47-52

[Article by V. Ye. Petrenko, candidate of technical sciences, and A. N. Belyakov, junior scientific associate, Kiev Polytechnical Institute]

[Text] The most effective methods of evaluating the state of complex engineering systems, for example gyromotors, are engineering diagnostic methods, based on decision-making theory. The purpose of the article is to solve the problem of classification of rotary systems (RS) with symmetrical ball-bearing (ShP) suspension.

The state of a rotary system is determined mainly by the quality of the ball-bearing seat, i.e., by defects in manufacture and assembly of the

ball bearing, which are described by random vector $x = (x_1, \dots, x_n)$.

The ball bearing of the seat can be diagnosed by parameters x_i , $i = \overline{1, n}$ only upon disassembly of the rotary system, which is not always possible in practice. The basic direction of modern diagnostics of rotary systems is nondestructive checking, which uses the determined functional relationships between the parameters of state x_i , $i = \overline{1, n}$ and the diagnostic observable signal z . The amplitude of the harmonic in the stiffness and vibration spectra of the rotary system will be this diagnostic signal z .

For the considered rotary systems, the dependence of z on defects of the ball bearing has the form [1]

$$z = [(x_1 x_2)^2 + (x_3 x_4)^2 + 2x_1 x_2 x_3 x_4 \cos x_5]^{1/2}, \quad (1)$$

where x_1 and x_2 are the amplitudes of the harmonics of defects on the races of the first ball bearing, x_3 and x_4 are the amplitudes of the harmonics of defects on the races of the second ball bearing, and x_5 is

the phase shift between the harmonics of defects on the races of the first and second ball bearings.

Variables x_i , $i = \overline{1, 4}$ are random values, distributed by Rayleigh law with probability density distribution [2]

$$f_{x_i}(u) = \frac{u}{\sigma_{x_i}^2} \exp\left(-\frac{u^2}{2\sigma_{x_i}^2}\right), \quad u > 0; \quad (2)$$

and the random value of x_5 has uniform density

$$f_{x_5}(u) = \frac{1}{\pi}, \quad u \in (0, \pi), \quad (3)$$

where u assigns the phase space of the random values of x_i , $i = \overline{1, 5}$. All the random values of x_i , $i = \overline{1, 5}$ are independent and accordingly the joint density $f_x = (u_1, \dots, u_5)$ for random vector $x = (x_1, \dots, x_5)$ is determined by the formula [3]

$$f_x(u_1, \dots, u_5) = \prod_{i=1}^5 f_{x_i}(u_i). \quad (4)$$

Since z is a function of x_i , $i = \overline{1, 5}$, z is also a random value. The density $f(z)$ of random value z can be determined on the basis of formula (1) by integration of joint density (4). Since the values of density (2) contain unknown parameters σ_{x_i} , $i = \overline{1, 4}$, the joint density (4) will

also contain them and this means that all σ_{x_i} , $i = \overline{1, 4}$ will go into density $f(z)$ in combination. The calculations become very cumbersome. Therefore, it is desirable to reduce the number of unknown parameters, which can be done on the basis of the engineering requirements on the ball-bearing seats. Using these requirements, one can show how the dispersions of the defects on the inner and outer races are related to each other for each ball bearing, i.e., one can assign the number γ_i , $i = \overline{1, 4}$, which determine the ratios between σ_{x_i} , $i = \overline{1, 4}$. As a result, all σ_{x_i} are easily reduced to one unknown parameter θ :

$\sigma_{x_i} = \gamma_i \theta, i = \overline{1, 4}$. The density $f(z, \theta)$ will then contain only one parameter θ .

To find expression $f(z, \theta)$ in parametric form, let us find the distribution function F_z , using relations (1)-(4). By definition

$$F_z(s) = P\{z < s\} = P\{[(x_1 x_2)^2 + (x_3 x_4)^2 + 2x_1 x_2 x_3 x_4 \cos x_5]^{1/2} < s\},$$

where P is a symbol of probability and s is the phase space of random value z . Let us introduce in formula (1) the substitution of variables

$$\xi_1 = x_1 x_2, \quad \xi_2 = x_3 x_4, \quad \xi_3 = \cos x_5. \quad (5)$$

Since the random values $x_i, i = \overline{1, 5}$ are independent, then $\xi_i, i = \overline{1, 3}$ are also independent. After replacement of (5), formula (1) assumes the form:

$$z = (\xi_1^2 + \xi_2^2 + 2\xi_1 \xi_2 \xi_3)^{1/2}. \quad (6)$$

The densities of random values $\xi_i, i = \overline{1, 3}$ are as follows:

$$f_{\xi_1}(u, \theta) = \frac{u}{\gamma_1^2 \gamma_2^2 \theta^4} \int_0^\infty \frac{1}{y} \exp\left[-\frac{1}{2\theta^2} \left(\frac{u^2}{\gamma_2^2 y^2} + \frac{y^2}{\gamma_1^2}\right)\right] dy, \quad (7)$$

$$f_{\xi_2}(v, \theta) = \frac{v}{\gamma_3^2 \gamma_4^2 \theta^4} \int_0^\infty \frac{1}{y} \exp\left[-\frac{1}{2\theta^2} \left(\frac{v^2}{\gamma_4^2 y^2} + \frac{y^2}{\gamma_3^2}\right)\right] dy, \quad (8)$$

$$f_{\xi_3}(w) = [\pi \sqrt{1-w^2}]^{-1}, \quad w \in (-1, 1). \quad (9)$$

The distribution functions $F_z(s)$ is found by integration of densities (7)-(9):

$$F_z(s) = \int \int \int_{D_s} f_{\xi_1}(u, \theta) f_{\xi_2}(v, \theta) f_{\xi_3}(w) du dv dw,$$

where D_s is the range of integration found on the basis of formula (6):

$$D_s: (u^2 + v^2 + 2uvw)^{1/2} < s.$$

Turning to cylindrical coordinates and having differentiated $F_z(s)$, we find

$$f(z, 0) = \frac{z^3}{4} \prod_{i=1}^N \gamma_i^2 \theta^8 \int_0^1 \frac{du}{\sqrt{a^2 - u^2}} \int_{-1}^1 \frac{|v|}{(v^2 + 2uv + 1)^2} \times$$

$$\times K_0 \left[\frac{z}{\gamma_1 \gamma_2 \theta^2 (v^2 + 2uv + 1)^{1/2}} \right] \times K_0 \left[\frac{z |v|}{\gamma_3 \gamma_4 \theta^2 (v^2 + 2uv + 1)^{1/2}} \right] dv, \quad (10)$$

where K_0 is a modified Bessel function of third kind [7]. Having used the known approximations for K_0 , we find

$$\hat{f}(z, 0) = \rho \theta^{-5} z^{3/2} \exp\left(-\frac{\xi}{\theta^2} z\right), \quad (11)$$

where the approximation error is $|\varepsilon| < 10^{-4}$, $\xi = 1,03806$, $\rho = (4\xi^{5/2}) / 3\sqrt{\pi}$.

A series of independent measurements of signal z is performed to estimate parameter θ and sample $\{z_i\}_{i=1}^N$ is found. Having sample $\{z_i\}_{i=1}^N$ and using the method of moments [3], due to which the computation is simple, we determine

$$\bar{m}_z = \frac{1}{N} \sum_{i=1}^N z_i, \quad m_I = \int_0^{\infty} z \hat{f}(z, 0) dz, \quad \bar{m}_z = m_I. \quad (12)$$

where \bar{m}_z is the first sampling moment and m_I is the first theoretical moment.

The theoretical moment m_I can be calculated in analytical form: $m_I = 5\xi^{-1}\theta^2$.

Having set m_I equal to the sampling moment \bar{m}_z , it is easy to find the estimate $\hat{\theta}$ of parameter θ : $\hat{\theta} = 1.0075$.

One can turn after calculation of estimate $\hat{\theta}$ to solution of the classification problem. To do this, let us use the Bayes criterion [4], since it is the most effective. Let us compile the probability ratio

$$\frac{f_2(z)}{f_1(z)} = \lambda_0, \quad \lambda_0 = \frac{(C_{21} - C_{11})P_1}{(C_{12} - C_{22})P_2}, \quad P_1 + P_2 = 1, \quad (13)$$

where $f_1(z)$ and $f_2(z)$ are arbitrary densities z of classes Ω_1 (suitable products) and Ω_2 (unsuitable products), respectively, P_1 and P_2 are the given probabilities that classes Ω_1 and Ω_2 will appear, and $\{C_{ij}\}$,

$i, j = \overline{1, 2}$ are elements of the loss matrix when making the decision. In our case the probability that an unsuitable product will appear is very small: $P_2 \ll P_1$. However, the cost of passing a defective product is considerably greater than the cost of a false alarm: $C_{12} \gg C_{21}$. According to [5], one can select $\lambda_0 = 1$ in this situation.

The main difficulty of using the Bayes criterion is in the laboriousness of finding complex densities $f_1(z)$ and $f_2(z)$. The procedure of numerically finding these densities analytically on the basis of functional relationship (1) and of a priori description of classes Ω_1 and Ω_2 is proposed in this paper. The classes are described in practice, using the technical documentation for the ball bearing. Based on the requirements on the ball-bearing seats, one can indicate the

tolerance a_i , $i = \overline{1, 4}$ for the i -th defect of ball bearing x_i (permissible misalignments of the races, dimensions of the balls and so on). It is thus easy to assign classes Ω_1 and Ω_2 in the following manner: 1) the product belongs to class Ω_1 at $0 < x_i < a_i$ and 2) the product belongs to class Ω_2 at $x_i > a_i$ (at least for one i , $i = \overline{1, 4}$). We find the conditional density $f_1(z)$ with this assignment of classes, using formula (1) and taking into account the constraints on variables x_i : $0 < x_i \leq a_i$, $i = \overline{1, 4}$ accordingly, from the condition of normalization for densities (2)

$$\beta_i \int_0^{a_i} f_{x_i}(u) du = 1$$

one must find the normalizing coefficients

$$\beta_i = \left[1 - \exp\left(-\frac{\alpha_i^2(0)}{2}\right) \right]^{-1};$$

After approximation, the conditional density $f_1(z)$ assumes the form

$$\hat{f}_1(z) = \frac{\prod_{i=1}^4 \beta_i}{\pi \prod_{i=1}^4 \gamma_i^2 0^8} \int_{-1}^1 \frac{1}{\sqrt{a^2 - w^2}} \Psi(z, w) dw, \quad (14)$$

where

$$\Psi(z, w) = \mu_1(w) z^{\mu_1(w)-1} \exp[-\mu_3(w) z^{\mu_3(w)}] [\mu_2(w) - \mu_3(w) \mu_4(w) z^{\mu_4(w)}];$$

$$\mu_k(w) = v_k^{(1)}(w+1) v_k^{(2)} [v_k^{(3)} - (w+1)] v_k^{(4)} + g_k, \quad k = \overline{1, 4}.$$

Having calculated the densities $\hat{f}(z)$ from (11) and $\hat{f}_1(z)$ from (14), the conditional density $\hat{f}_2(z)$ can be determined by the formula

$$\hat{f}_2(z) = \frac{1}{P_2} (\hat{f}(z) - P_1 \hat{f}_1(z)).$$

After substitution into (13), densities $\hat{f}_1(z)$ and $\hat{f}_2(z)$ were approximated at $\theta = 1$, $\alpha_i = 2.4426$, $i = \overline{1, 3}$, $\alpha_i = 4.885$, and $i = 2, 4$ by simpler distributions while retaining high accuracy ($|\epsilon| < 8.1 \cdot 10^{-5}$)

$$\tilde{f}_1(z) = \rho_1 z \exp(-\tau_1 z), \quad \tilde{f}_2(z) = \rho_2 z \exp(-\tau_2 z), \quad (15)$$

where $\rho_1 = 0.44564$, $\tau_1 = 2/3$, $z \in (0, b_1)$, $b_1 = 12.3$; for $\tilde{f}_1(z)$ and $\rho_2 = 2.119 \cdot 10^{-2}$, $\tau_2 = 1/8$, $z \in (0, \infty)$ for $\tilde{f}_2(z)$.

Having substituted (15) into equation (13) and having solved it with respect to z , we find the number z_0 which separates classes Ω_1 and Ω_2 . If there are probabilities that classes $P_1 = 0.9$, $P_2 = 0.1$ and $\lambda_0 = 1$ will appear, $z_0 = 5.604999$ will be found. Thus, the product is assumed suitable at $z \leq z_0$ and is considered unsuitable at $z > z_0$.

The quality of recognition is evaluated by the probabilities of errors of first and second kind [6]. If the object belongs to class Ω_1 and is assumed to be an object of class Ω_2 , this error is called an error of first kind. On the contrary, if the object belongs to class Ω_2 and is

erroneously related to class Ω_1 , an error of second kind is made. The most complete characteristic of the quality of recognition is the average risk R , which takes both types of errors into account. The probabilities of errors of first kind Q_1^P , of second kind Q_2^P and average risk R are determined in the following manner:

$$Q_1^P = \int_{z_0}^{\infty} \tilde{f}_1(z) dz, \quad Q_2^P = \int_0^{z_0} \tilde{f}_2(z) dz,$$

$$R = P_1 C_{12} Q_1^P + P_2 C_{21} Q_2^P.$$

Since we used the value $\lambda_0 = 1$, then $C_{21} = P_1$, $C_{12} = P_2$, $R = r(Q_1^P + Q_2^P)$, where $r = P_1 P_2$, $r = 0,09$, $Q_1^P = 1,05738\%$, $Q_2^P = 4,83152\%$, $R = 0,5889\%$.

Errors of the first and second kind and the average risk were small, which indicates high quality of recognition and permits one to recommend the suggested approach for solving problems of evaluating the state of symmetrical rotary systems.

BIBLIOGRAPHY

1. Petrenko, V. Ye. A. N. Belyakov, Ye. G. Levchuk, and A. I. Batov, "Characteristic Features of Describing Variations of the Axial Stiffness of a Rotary System," MEKHANIKA GIROSKOPICHESKIKH SISTEM, No 5, 1986.
2. Ventsel, Ye. S., "Teoriya veroyatnostey" [Probability Theory], Moscow, 1964.
3. Kramer, G., "Matematicheskiye metody statistiki" [Mathematical Methods of Statistics], Moscow, 1975.
4. Fukunaga, K., "Vvedeniye v statisticheskuyu teoriyu raspoznavaniya obrazov" [Introduction to the Statistical Theory of Pattern Recognition], Moscow, 1979.
5. Birger, I. A., "Tekhnicheskaya diagnostika" [Engineering Diagnostics], Moscow, 1978.
6. Gorelik, A. L. and V. A. Skripnik, "Metody raspoznavaniya" [Methods of Recognition], Moscow, 1977.
7. "Spravochnik po spetsialnym funktsiyam s formulami, grafikami i matematicheskimi tablitsami" [Handbook on Special Functions With Formulas, Graphs and Mathematical Tables], edited by M. Abramovits and I. Stigan, Moscow, 1979.

UDC 531.383

DYNAMICS OF SURVEYOR'S GYROCOMPASS

907F0290L Kiev MEKHANIKA GIROSKOPICHESKIKH SISTEM in Russian, Issue 8, 1989 (manuscript received 11 Nov 87) pp 52-57

[Article by V. Ye. Petrenko, candidate of technical sciences, S. A. Zakharenko, candidate of technical sciences, and A. Ye. Ponomarenko, engineer, Kiev Polytechnical Institute]

[Text] Close attention has traditionally been devoted to study of the dynamics of precision gyroscopes. An object of detailed study is the influence of the parameters of ball bearing (ShP) imperfections on the position of the resonant zones of the devices [1]. The parametric effect on the vibrations of the devices as a perturbing factor have not been considered previously. Study of the dynamics and calculation of the natural frequencies of a surveyor's gyrocompass upon the parametric effects of an imperfect ball bearing are the purpose of this paper.

Let us take as the perturbing factor the deviations of the coordinates of the centers of curvature of the outer races in the axial cross-sections of the ball-bearing seat along the rotor axis from their true values when deriving the equations of motion of a surveyor's gyrocompass, which is the sensitive element (ChE) on a torsion bar suspension. Disregarding the interaction of the sensitive element with a rotating earth, let us assume that the rotor in the device makes only axial displacements and that its position in the device is ideal, i.e., there is no unbalance.

Let us introduce into consideration a fixed coordinate system $O_1X_1Y_1Z_1$ (Figure 1), bound to the center of mass of the sensitive element without a rotor in the initial unperturbed position, and movable coordinate system $O_0X_0Y_0Z_0$, rigidly bound to the center of mass of the sensitive element without a rotor. The position of point O_0 in coordinate system

$O_1X_1Y_1Z_1$ will be given by vector $\vec{r}_1 = r_1(x_1, y_1, z_1)$ at an arbitrary moment of time. Let us rigidly link coordinate system $C\xi\eta\zeta$ to the center of mass of the rotor. The position of the rotor at arbitrary moment of time will be given in coordinate system $O_0X_0Y_0Z_0$. Let us determine its axial displacements by coordinate z . Let us give the

angular displacements of the sensitive element without a rotor by a system of angles of finite rotation α , β , γ . The sequence of revolutions is shown in Figure 2. Let us determine the rotation of the rotor along the axis of its own moment of momentum by angle γ_p .

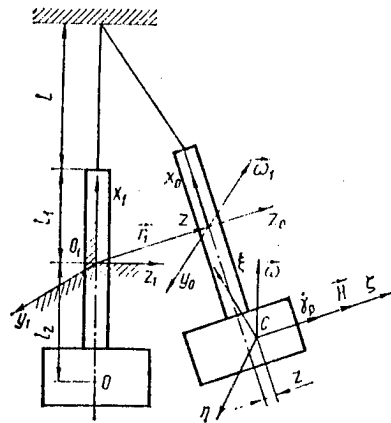

Figure 1

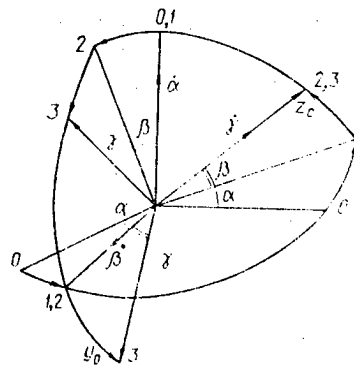

Figure 2

Let l be the length of the torsion bar, let l_1 be the distance from the point of attachment of the torsion bar to the sensitive element to the center of mass of the sensitive element without a rotor, let l_2 be the distance from the center of mass of the sensitive element without a rotor to the center of mass of the rotor, let $\vec{\omega}_1 = \{\omega_{x_0}, \omega_{y_0}, \omega_{z_0}\}$ and $\vec{\epsilon}_1 = \{\epsilon_{x_0}, \epsilon_{y_0}, \epsilon_{z_0}\}$ be vectors of the angular velocities and accelerations of the sensitive element without a rotor in projections onto the axes of coordinate system $O_0X_0Y_0Z_0$, and let $\vec{\omega} = \{\omega_\xi, \omega_\eta, \omega_\zeta\}$ be the vector of the

angular velocities of the rotor in projections onto the axes of coordinate system $C\xi\eta\zeta$:

$$\vec{K}_{O_0}^\omega = \begin{vmatrix} I_{x_0} & 0 & 0 \\ 0 & I_{y_0} & 0 \\ 0 & 0 & I_{z_0} \end{vmatrix} \vec{\omega}_1$$

is the torque of the sensitive element without a rotor with respect to pole O_0 ,

$$\vec{K}_C^\omega = \begin{vmatrix} I_\xi & 0 & 0 \\ 0 & I_\eta & 0 \\ 0 & 0 & I_\zeta \end{vmatrix} \vec{\omega}$$

is the torque of the rotor with respect to pole C , I_{x_0} , I_{y_0} , and I_{z_0} are the moments of inertia of the sensitive element without a rotor with respect to axes O_0X_0 , O_0Y_0 , and O_0Z_0 , respectively, I_ξ , I_η , and I_ζ are the moments of inertia of the rotor with respect to axes $C\xi$, $C\eta$, and $C\zeta$, and C_ξ , C_η , C_ζ ; $\vec{r}_0 = \{x_0, 0, 0\}$; $\vec{r} = \{0, 0, z\}$; $x_0 = -l_2$.

Let us use the Euler-Ishlinskiy method to compile the equations of motion of the sensitive element. Considering the interaction between the bodies--a sensitive element with a rotor and one without a rotor--we find the following equations of motion in vector form:

$$\begin{aligned} M(\vec{W}_C - \vec{g}) &= \vec{Q}_C, \\ m(\vec{W}_{O_0} - \vec{g}) &= \vec{P}_{O_0} - \vec{Q}_{O_0}, \\ \frac{d\vec{K}_C^\omega}{dt} + \vec{\omega} \times \vec{K}_C^\omega &= \vec{M}_C, \\ \frac{d\vec{K}_{O_0}^\omega}{dt} + \vec{\omega}_1 \times \vec{K}_{O_0}^\omega &= \vec{L}_{O_0} - \vec{M}_{O_0} - (\vec{r}_0 + \vec{r}) \times \vec{Q}. \end{aligned} \quad (1)$$

Here M is the mass of the rotor, m is the mass of the sensitive element without a rotor, \vec{Q} is a vector of forces acting on the rotor, \vec{P} is the vector of forces acting on the sensitive element without a rotor, \vec{g} is

free-fall acceleration, and \vec{W}_{O_0} , \vec{W}_C and \vec{M}_{O_0} , \vec{M}_C are vectors of the absolute accelerations and moments of the centers of mass of the sensitive element without a rotor and with a rotor, respectively.

Let us write the components of vector $\vec{\omega}_1$ (see Figure 2):

$$\begin{aligned}\omega_{x_0} &= \dot{\beta} \sin \gamma + \dot{\alpha} \cos \beta \cos \gamma, & \omega_{y_0} &= \dot{\beta} \cos \gamma - \dot{\alpha} \sin \gamma \cos \beta, \\ \omega_{z_0} &= \dot{\gamma} + \dot{\alpha} \sin \beta.\end{aligned}\quad (2)$$

The total potential energy of the sensitive element includes that of the sensitive element in the earth's gravity field Π_1 and the energy of elastic deformation of the imperfect ball-bearing seat Π_2 [2]. With the adopted assumptions we write

$$\begin{aligned}\Pi_1 &= Mg(x^* - x_0) + mgx_1, \\ \Pi_2 &= \frac{2}{5} \sum_{j=1}^2 Kn\omega_j^{\frac{5}{2}}, \\ \omega_j &= \left\{ (\rho_1 + \rho_2 - \rho_3 + \rho_4)^2 + [z + (-1)^{j+1}\rho_6 - (-i)^j(\rho_5 - z^0)]^2 - \right. \\ &\quad \left. - (\rho_1 + \rho_2 - \rho_7) \right\}^{\frac{1}{2}}.\end{aligned}\quad (3)$$

Here p_j are the parameters of imperfection of the ball bearing after V. F. Zhuravlev, z^0 is the tension in the gyromotor, n is the number of balls, K is Hertz's coefficient, x^* is the coordinate of the center of mass of the rotor in coordinate system $O_1X_1Y_1Z_1$:

$$x^* = x_1 + x_0 \cos \beta \cos \gamma + z \sin \beta. \quad (4)$$

When writing the potential energy, let us take into account that the introduced coordinates are related in the following manner [1]:

$$\begin{aligned}x_1 - l - l_1 &= -l \cos \lambda \cos \mu - l_1 \cos \beta \cos \gamma, \\ y_1 &= -l \sin \mu - l_1 (\cos \alpha \sin \gamma + \sin \alpha \sin \beta \cos \gamma), \\ z_1 &= l \sin \lambda \cos \mu - l_1 (\sin \alpha \sin \gamma - \sin \beta \cos \alpha \cos \gamma),\end{aligned}$$

where λ and μ assign the position of the torsion bar in $O_1X_1Y_1Z_1$.

Hence, we find with regard to the smallness of the angular displacements

$$x_1 = [y_1 + l_1(\gamma + \alpha\beta)]^2/(2l) + [z_1 + l_1(\alpha\gamma - \beta)]^2/(2l) + l_1\beta^2/2 + l_1\gamma^2/2. \quad (5)$$

Thus, the expression for the total potential energy with regard to (3)-(5) will assume the form

$$\begin{aligned} \Pi = & (M + m)g \{ [y_1 + l_1(\gamma + \alpha\beta)]^2/(2l) + [z_1 + l_1(\alpha\gamma - \beta)]^2/(2l) + \\ & + l_1\beta^2/2 + l_1\gamma^2/2 \} - Mg x_0(\beta^2 + \gamma^2)/2 + Mg\beta z + \frac{2}{5} \sum_{j=1}^2 K_n \{ \{ p_1 + \\ & + p_2 - p_3 + p_4 \}^2 + [z + (-1)^{j+1} p_6 - (-1)^j (p_5 - z^0)]^2 \}^{\frac{1}{2}} - \\ & - p_1 - p_2 + p_7 \}^{\frac{5}{2}}. \end{aligned} \quad (6)$$

Let us find the expressions for the moments and forces on the right sides of (1). Denoting $\vec{M}_{O_0} = \{M_{x_0}, M_{y_0}, M_{z_0}\}$, $\vec{M}_C = \{M_\xi, M_\eta, M_\zeta\}$, $\vec{Q}_G = \{Q_\xi, Q_\eta, Q_\zeta\}$, $\vec{Q}_{O_0} = \{Q_{x_0}, Q_{y_0}, Q_{z_0}\}$, $\vec{P}_{O_0} = \{P_{x_0}, P_{y_0}, P_{z_0}\}$, we write

$$\begin{aligned} L_{x_0} = Q_\xi = Q_\eta = Q_{x_0} = Q_{y_0} = 0, \\ L_{y_0} = (M + m)g \{ [z_1 + l_1(\alpha\gamma - \beta)] l_1 - l l_1 \beta \} / l + Mg(x_0 \beta - z), \\ L_{z_0} = Mg x_0 \gamma - (M + m)g \{ [y_1 + l_1(\gamma + \alpha\beta)] l_1 + l l_1 \gamma \} / l, \\ M_\xi = M_{x_0} \cos \gamma_p + M_{y_0} \sin \gamma_p, \quad M_\eta = M_{y_0} \cos \gamma_p - M_{x_0} \sin \gamma_p, \\ M_\zeta = M_{z_0}, \\ P_{y_0} = -(M + m)g [y_1 + l_1(\gamma + \alpha\beta)] / l, \quad P_{z_0} = -(M + m) \times \\ \times g [z_1 + l_1(\alpha\gamma - \beta)] / l, \quad Q_\zeta = Mg\beta - (Kz + K_{zp} p_5) z - K_p p_5. \end{aligned} \quad (7)$$

Here

$$\frac{\partial \Pi}{\partial z} = (K_z + K_{zp} p_5) z + K_p p_5, \quad (8)$$

where K_z , K_p , and K_{zp} are the coefficients of expansion of the elastic force acting in an imperfect ball bearing into a Taylor series.

Based on equations (1), (2), (6), and (7), we find the following linearized system of differential equations:

$$\Lambda_1 \{\alpha\beta\gamma y_1 z_1 z\}^T = \{f_1 f_2 0 0 f_3 f_4\}. \quad (9)$$

Here $f_1 = 0$; $f_2 = l_2 K_p \rho_5 / (I_{y_0} + I_3)$; $f_3 = K_p \rho_5 / m$; $f_4 = -(M+m) \times K_p \rho_5 / (mM) - l_2^2 K_p \rho_5 / (I_{y_0} + I_3)$, $H = I_{\xi} \dot{\gamma}_p$, $I_3 = I_{\xi} = I_{\eta}$;

$$\Lambda_1 = \begin{vmatrix} p^2 & H_1 p & 0 & 0 & 0 & 0 \\ -H_2 p & p^2 + B_2 & 0 & 0 & -B_1 & B_3 \\ 0 & 0 & p^2 + D_2 & D_1 & 0 & 0 \\ 0 & 0 & C_1 l_1 & p^2 + C_1 & 0 & 0 \\ 0 & -C_2 & 0 & 0 & p^2 + C_1 & -\frac{K_0}{m} \\ l_2 H_2 p & N_1 & 0 & 0 & N_2 & p^2 + N_3 \end{vmatrix},$$

where p is a differentiation operator;

$$\begin{aligned} K_0 &= K_z + K_z \gamma p_5; & H_1 &= H / (I_{x_0} + I_3); & H_2 &= H / (I_{y_0} + I_3); & B_1 &= \\ &= (M+m) g l_1 / l (I_{y_0} + I_3); & B_2 &= [M g l_2 + (M+m) g l_1 (l + l_1) / l] / \\ & / (I_{y_0} + I_3); & B_3 &= [M g - l_2 K_0 / (I_{y_0} + I_3)]; & C_1 &= (M+m) g / (m l); \\ C_2 &= (M+m) g l_1 / (m l) + M g / m; & N_1 &= -B_2 l + C_2 + g; \\ N_2 &= -C_1 + l B_1; & N_3 &= -B_3 l_2 + (m+M) K_0 / (mM). \end{aligned}$$

Setting the determinant of matrix Λ_1 equal to zero, we find the following characteristic equation:

$$p^{10} + d_1 p^8 + d_2 p^6 + d_3 p^4 + d_4 p^2 + d_5 = 0, \quad (10)$$

where

$$\begin{aligned} d_1 &= 2C_1 + D_2 + N_3 + B_2 + H_1 H_2; & d_2 &= 2C_1 D_2 + C_1^2 + 2C_1 N_3 + \\ & + [D_2 N_3 + (2C_1 + D_2 + N_3)(B_2 + H_1 H_2) + K_0 N_2 / m - D_1 C_1 l_1 - B_1 C_2 + \\ & + B_3 N_1 + l_2 H_1 H_2 B_3]; & d_3 &= C_1^2 D_2 + 2C_1 D_2 N_3 + C_1^2 N_3 + (2C_1 D_2 + C_1^2 + \end{aligned}$$

$$\begin{aligned}
& + 2C_1N_3 - D_1C_1l_1 + D_2N_3)(B_2 + H_1H_2) - (C_1 + N_3)D_1C_1l_1 + \\
& + (B_2 + H_1H_2 + C_1 + D_2)K_0N_2/m + (N_1 - l_2H_1H_2)B_1K_0/m + \\
& + B_3C_2N_2 - B_1C_2(C_1 + D_2 + N_3) + (2C_1 + D_2)(B_3N_1 + l_2H_1H_2B_3); \\
d_4 = & C_1(N_3C_1 - B_1C_2 + K_0N_2/m)(D_2 - D_1l_1) + [C_1^2D_2 + 2C_1D_2N_3 + \\
& + C_1^2N_3 - C_1^2D_1l_1 - N_3D_1C_1l_1 + (C_1 + D_2)K_0N_2/m](B_2 + H_1H_2) + \\
& + (C_1 + D_2)B_1K_0(N_1 - l_2H_1H_2)/m + (C_1 + D_2)(B_3 - B_1)C_2N_2 + \\
& + B_3C_1(2D_2 + C_1 - D_1l_1)(N_1 + l_2H_1H_2); \quad d_5 = (N_3C_1^2 + C_1K_0N_2/m) \times \\
& \times (D_2 - D_1l_1)(B_2 + H_1H_2) + (C_1B_1N_1K_0/m - C_1l_2H_1H_2B_1K_0/m + \\
& + C_1^2B_3N_1 + C_1^2l_2H_1H_2B_3 - B_1C_1C_2N_3)(D_2 - D_1l_1) + B_3C_1N_2 \times \\
& \times (C_2D_2 - D_1l_1l_2).
\end{aligned}$$

The roots of characteristic equation (10) give us values of the natural frequencies. At $\gamma = y_1 = 0$

$$\begin{aligned}
\omega_1 &= \{g_3/g_2(1 + g_1g_3/g_2^2)\}^{1/2}, & (11) \\
\omega_{2,3} &= \{(g_1^2 - 2g_2 \pm [(g_1^2 - 2g_2)^2 - 4(g_2^2 - 2g_1g_3)]^{1/2})/2\}^{1/4},
\end{aligned}$$

where

$$\begin{aligned}
g_1 &= N_3 + B_2 + C_1 + H_1H_2; \quad g_2 = -l_2C_1B_3 + B_2N_3 + (m + M) \times \\
& \times K_0(C_1 + H_1H_2)/(m\lambda) + C_1B_2 + C_1H_1H_2 - B_3N_1 + K_0N_2/m - C_2B_1; \\
g_3 &= -K_0(C_2B_1 - C_1B_2 - C_1H_1H_2)/\lambda + (B_1K_0/m - B_1C_1)g.
\end{aligned}$$

Let us calculate the values of the natural frequencies of the sensitive element with the following input data: $M = 0.6$ kg, $m = 0.9$ kg, $l = 0.16$ m, $l_1 = 0.15$ m, $l_2 = 0.16$ m, $I_{x_0} = 12.74 \cdot 10^{-4}$ kg·m², $I_{y_0} = 13.72 \cdot 10^{-4}$ kg·m², $I_{z_0} = 7.22 \cdot 10^{-4}$ kg·m², $I_{\vartheta} = 58.8 \cdot 10^{-4}$ kg·m², $I_0 = 9.8 \cdot 10^{-4}$ kg·m², $H = 0.4$ kg·m²/s, $K_z = 0.43$ kg/μm, $p_5 = 43.5$ μm, and $K_{zp} = 0.086$ kg/μm².

Formulas (11) yield $\omega_1^1 = 7.7$ s⁻¹; $\omega_2^1 = 81.5$ s⁻¹; $\omega_3^1 = 8295$ s⁻¹.

Comparing the value of ω^I_2 to the value of nutational frequency $\omega^* = H/\sqrt{(I_{x_0} + I_3)(I_{y_0} + I_3)} = 107$ s⁻¹, we see that ω^I_2 is less than 20 percent less than ω^* , which is in agreement with known experimental results.

The roots of characteristic equation (10) yield refined values of the natural frequencies of the sensitive element: $\omega_1^{II} = 6,5 \text{ s}^{-1}$; $\omega_2^{II} = 8,8 \text{ s}^{-1}$; $\omega_3^{II} = 24,4 \text{ s}^{-1}$; $\omega_4^{II} = 83 \text{ s}^{-1}$; $\omega_5^{II} = 8294 \text{ s}^{-1}$.

Thus, one can calculate the fundamental natural frequencies with sufficient degree of accuracy by formulas (11). Consideration of the cross stiffness of the ball bearing $K_{z\varphi}$ in expansion (8) permitted us to

determine the accurate values of the maximum resonant frequencies ω_3^I and ω_5^{II} . Numerical integration of system (9) by the fourth-order Runge-Kutta method at nutational frequency $\omega_2^I = 81.5 \text{ s}^{-1}$ with perturbation amplitude of parameter p_5 equal to $3.6 \text{ }\mu\text{m}$ showed the presence of a second parametric (harmonic) resonance of the studied system.

BIBLIOGRAPHY

1. Bashirov, R. Kh., "On Study of the Dynamics of a Gyrocompass Based on a Torsion-Bar Suspension, IZVESTIYA AKADEMII NAUK SSSR, MEKHANIKA TVERDOGO TELA, No 2, 1984.
2. Pavlovskiy, M. A., V. Ye. Petrenko, and S. A. Zakharenko, "Natural Vibrations of the Rotor in Imperfect Bearings Containing Polymer Elements," MEKHANIKA GIROSKOPICHESKIKH SISTEM, No 3, 1984.

UDC 539. 30/32

ON PARAMETRIC VIBRATIONS OF VIBRATION-INSULATED PENDULUM

907F0290M Kiev MEKHANIKA GIROSKOPICHESKIKH SISTEM in Russian, Issue 8, 1989 (manuscript received 21 Oct 87) pp 57-62

[Article by L. M. Ryzhkov, candidate of technical sciences, Kiev Polytechnical Institute]

One of the characteristic features of the dynamics of pendulum devices is the presence of unstable parametric vibrations upon vertical vibration of the base, which can be eliminated by introducing the required damping into the system [1]. Let us consider these vibrations in a pendulum, vibration-insulated in the horizontal plane, studying the case when the vibration frequencies exceed the resonant frequencies of the system.

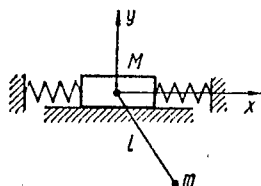

A body of mass M (the body of the device), connected to the base by springs that perform the function of vibration insulator, moves in the horizontal plane (see figure). A pendulum of length l and mass m is mounted in the body. The base completes vertical vibrations at acceleration $W_y = \epsilon W \cos \Omega t$, where ϵ is a small value.

The equations of motion of the system are written in the following manner:

$$\begin{aligned} (M + m)\ddot{x} + ml\ddot{\varphi} \cos \varphi + h_1\dot{x} + cx - ml\dot{\varphi}^2 \sin \varphi &= 0, \\ I_0\ddot{\varphi} + h_2\dot{\varphi} + ml(l\ddot{\varphi} + \ddot{x} \cos \varphi - \dot{x}\dot{\varphi} \sin \varphi) + ml(g + W_y) \sin \varphi &= 0, \end{aligned} \quad (1)$$

where x is the displacement of the body of the device, φ is the angle of rotation of the pendulum, I_0 is the moment of inertia of the pendulum, c is the stiffness of the elastic coupling, and h_1 and h_2 are damping coefficients.

Limiting ourselves to second-order values inclusively, we transform system (1) to the form

$$\begin{aligned} \ddot{\varphi} + \xi k_1 \dot{\varphi} + k_1^2(1 + r_y)\varphi + k_1^2 g^{-1} \ddot{x} &= 0, \\ \ddot{x} + \zeta k_2 \dot{x} + k_2^2 x + b \ddot{\varphi} &= 0, \end{aligned} \quad (2)$$

where $k_1 = \sqrt{\frac{mgl}{I}}$; $k_2 = \sqrt{\frac{c}{M+m}}$ are partial frequencies, $I = I_0 + ml^2$; $b = \frac{ml}{M+m}$; $r_y = g^{-1}W_y$; and ξ , ζ are relative damping coefficients.

Let us use the averaging method to solve the system of equations. Let us find the solutions in the form

$$\begin{aligned} \varphi &= \sum_{j=1}^2 C_j e^{i\omega_j t} + D_j e^{-i\omega_j t}, \\ x &= \sum_{j=1}^2 \mu_j (C_j e^{i\omega_j t} + D_j e^{-i\omega_j t}), \end{aligned} \quad (3)$$

where C_j and D_j are complex unknowns, $i = \sqrt{-1}$; $\mu_j = \frac{b\omega_{j0}}{k_2^2 - \omega_{j0}^2}$ is a coefficient of forms, ω_{j0} is the frequency of natural vibrations of system (2) in the absence of damping, and ω_j is the vibration frequency.

Let us introduce frequency tuning $\varepsilon \eta_j$, having written

$$\omega_j^2 = \omega_{j0}^2 (1 - \varepsilon \eta_j). \quad (4)$$

Having substituted (3) into system (2), we find by the method of [2]

$$\begin{aligned}
\dot{C}_1 &= \Delta^{-1} \langle e^{-i\omega_1 t} (R_1 v_2 - R_2 d_2) \rangle, \\
\dot{D}_1 &= -\Delta^{-1} \langle e^{i\omega_1 t} (R_1 v_2 - R_2 d_2) \rangle, \\
\dot{C}_2 &= \Delta^{-1} \langle e^{-i\omega_2 t} (R_2 d_1 - R_1 v_1) \rangle, \\
\dot{D}_2 &= -\Delta^{-1} \langle e^{i\omega_2 t} (R_2 d_1 - R_1 v_1) \rangle,
\end{aligned} \tag{5}$$

where

$$\begin{aligned}
\Delta &= d_1 v_2 - d_2 v_1; \quad R_1 = -a_j A_j - \rho (e^{i\Omega t} + e^{-i\Omega t}) A_j - s_j B_j; \quad R_2 = \\
&= -q_j A_j - f_j B_j; \quad d_j = \alpha_j 2i\omega_j; \quad v_j = 2i\omega_j \kappa_j; \quad a_j = k_1^2 \varepsilon \eta_j \alpha_j; \\
q_j &= k_1^2 \varepsilon \eta_j \kappa_j; \quad \alpha_j = 1 + k_1^2 g^{-1} \mu_j; \quad \kappa_j = \frac{b k_2^2}{k_2^2 - \omega_{j0}^2}; \quad f_j = \xi k_2 \mu_j i \omega_j; \\
\rho &= \frac{1}{2} k_1^2 r_{y0}; \quad s = \xi k_1 i \omega_j; \quad r_{y0} = g^{-1} \varepsilon W_0; \quad A_j = C_j e^{i\omega_j t} + D_j e^{-i\omega_j t}; \\
B_j &= C_j e^{i\omega_j t} - D_j e^{-i\omega_j t}.
\end{aligned}$$

Analyzing expressions (5), we find that non-trivial solutions are possible in the cases

$$\begin{aligned}
R_1 e^{-i\omega_1 t} &= -n_1 C_1 - \rho D_1, \quad \langle R_1 e^{i\omega_1 t} \rangle = -u_1 D_1 - \rho C_1, \quad \langle R_1 e^{-i\omega_1 t} \rangle = \\
&= -n_2 C_2, \quad \langle R_1 e^{i\omega_2 t} \rangle = -u_2 D_2; \\
b) \quad 2\omega_2 &= \Omega: \\
\langle R_1 e^{-i\omega_1 t} \rangle &= -n_1 C_1, \quad \langle R_1 e^{i\omega_1 t} \rangle = -u_1 D_1, \quad \langle R_1 e^{-i\omega_2 t} \rangle = -n_2 C_2 - \rho D_2, \\
\langle R_1 e^{i\omega_2 t} \rangle &= -u_2 D_2 - \rho C_2; \\
c) \quad \omega_2 + \omega_1 &= \Omega: \\
\langle R_1 e^{-i\omega_1 t} \rangle &= -n_1 C_1 - \rho D_2, \quad \langle R_1 e^{i\omega_1 t} \rangle = -u_1 D_1 - \rho C_2; \quad \langle R_1 e^{-i\omega_2 t} \rangle = \\
&= -n_2 C_2 - \rho D_1, \quad \langle R_1 e^{i\omega_2 t} \rangle = -u_2 D_2 - \rho C_1; \\
d) \quad \omega_2 - \omega_1 &= \Omega: \\
\langle R_1 e^{-i\omega_1 t} \rangle &= -n_1 C_1 - \rho C_2; \quad \langle R_1 e^{i\omega_1 t} \rangle = -u_1 D_1 - \rho D_2, \quad \langle R_1 e^{-i\omega_2 t} \rangle = \\
&= -n_2 C_2 - \rho C_2, \quad \langle R_1 e^{i\omega_2 t} \rangle = -u_2 D_2 - \rho D_1, \quad \ddagger
\end{aligned}$$

where $n_\alpha = a_\alpha + s_\alpha$; $u_\alpha = a_\alpha - s_\alpha$; $\alpha = 1, 2$.

The following relations occur for all four cases

$$\begin{aligned} \langle R_2 e^{-i\omega_1 t} \rangle &= -(q_1 + f_1) C_1, & \langle R_2 e^{i\omega_1 t} \rangle &= -(q_1 - f_1) D_1, & \langle R_2 e^{-i\omega_2 t} \rangle &= \\ &= -(q_2 + f_2) C_2, & \langle R_2 e^{i\omega_2 t} \rangle &= -(q_2 - f_2) D_2. \end{aligned}$$

We assume that $\omega_2 > \omega_1$. Cases b and c are of interest with respect to the considered postulation of the problem ($\Omega > \omega_2$).

If condition $2\omega_2 = \Omega$ is fulfilled

$$\begin{aligned} \Delta \dot{C}_1 &= [-v_2(a_1 + s_1) + d_2(q_1 + f_1)] C_1, \\ \Delta \dot{D}_1 &= [v_2(a_1 - s_1) - d_2(q_1 - f_1)] D_1, \\ \Delta \dot{C}_2 &= -d_1(q_2 + f_2) C_2 + v_1[(a_2 + s_2) C_2 + \rho D_2], \\ \Delta \dot{D}_2 &= d_1(q_2 - f_2) D_2 - v_1[(a_2 - s_2) D_2 + \rho C_2]. \end{aligned} \tag{6}$$

We find the conditions of stability of the solutions of system of equations (6), which is divided into two subsystems. Analysis of the first subsystem, which includes the first and second equations, shows that its solutions are stable. The condition of stability has the form

$$\frac{k_2^2}{\omega_{20}^2 - k_2^2} \xi k_1 + \alpha_2 \frac{\omega_{10}^2}{k_2^2 - \omega_{10}^2} \zeta k_2 > 0.$$

Let us consider the second subsystem, having written it as follows:

$$\Delta \dot{C}_2 + u_{1C} C_2 + u_{1D} D_2 = 0, \quad u_{2C} C_2 + \Delta \dot{D}_2 + u_{2D} D_2 = 0, \tag{7}$$

where $u_{1C} = d_1(q_2 + f_2) - v_1(a_2 + s_2)$; $u_{1D} = -v_1\rho$; $u_{2C} = v_1\rho$; $u_{2D} = -d_1(q_2 - f_2) +$
+ eq

The following conditions should be fulfilled for stability of vibrations

$$u_{1C} + u_{2D} > 0, \quad u_{1C}u_{2D} - u_{2C}u_{1D} > 0. \tag{8}$$

The first inequality can be transformed to the form

$$\frac{\xi \alpha_1 \omega_{20}^2}{\omega_{20}^2 - k_2^2} + \frac{\xi k_1 k_2}{k_2^2 - \omega_{10}^2} > 0. \quad (9)$$

Since $\omega_{20} > k_2$ and $\omega_{10} < k_2$, inequality (9) is always fulfilled.

The second inequality can be written in the form

$$(\alpha_1 \xi k_2 \mu_2 - \xi k_1 \alpha_1)^2 \omega_2^2 + k_1^4 (\epsilon \eta_2)^2 (\alpha_1 \alpha_2 - \alpha_2 \alpha_1)^2 - \alpha_1^2 \rho^2 > 0. \quad (10)$$

Let the frequency tuning $\epsilon \eta_2$ be equal to zero. Inequality (10) is then simplified:

$$\omega_{20} \left[\alpha_1 \xi \frac{(k_2^2 - \omega_{10}^2) \omega_{20}^2}{(\omega_{20}^2 - k_2^2) k_2} + \xi k_1 \right] > \frac{1}{2} k_1^2 r_{y0}. \quad (11)$$

Thus, if inequality (11) is fulfilled, the vibrations will be stable. If damping in the vibration insulator is very small, inequality (11) is simplified considerably and the condition of stability is written thusly:

$$r_{y0} < 2 \frac{\omega_{20}}{k_1} \xi. \quad (12)$$

Accordingly, stability can also be guaranteed with small damping in the vibration insulator by appropriate selection of damping in the pendulum.

Let us now consider the case $\omega_2 + \omega_1 = \Omega$. System of equations (5) decomposes into two subsystems:

$$\Delta \dot{C}_1 + \lambda_{1C} C_1 + \lambda_{1D} D_2 = 0, \quad \Delta \dot{D}_2 + \lambda_{2D} D_2 + \lambda_{4C} C_1 = 0; \quad (13)$$

$$\Delta \dot{D}_1 + \lambda_{1D} D_1 + \lambda_{2C} C_2 = 0, \quad \Delta \dot{C}_2 + \lambda_{2C} C_2 + \lambda_{3D} D_1 = 0, \quad (14)$$

where $\lambda_{1C} = v_2(a_1 + s_1) - d_2(q_1 + f_1)$; $\lambda_{1D} = -v_2(a_1 - s_1) + d_2(q_1 - f_1)$; $\lambda_{2C} = u_{1C}$; $\lambda_{2D} = u_{2D}$; $\lambda_3 = v_2 \rho$; $\lambda_4 = -\lambda_1$; $\lambda_5 = -v_1 \rho$; $\lambda_6 = -\lambda_3$.

The characteristic equations of system (13) and (14) have the form

$$\Delta^2 p^2 + \Delta(\lambda_{1C} + \lambda_{2D})p + \lambda_{1C}\lambda_{2D} - \lambda_1\lambda_4 = 0; \quad (15)$$

$$\Delta^2 p^2 + \Delta(\lambda_{1D} + \lambda_{2C})p + \lambda_{1D}\lambda_{2C} - \lambda_2\lambda_3 = 0. \quad (16)$$

Let us assume that $\epsilon\eta_1 = \epsilon\eta_2 = 0$. The conditions of stability for equations (15) and (16) are then written in the following manner:

$$\begin{aligned} \xi k_1 \left(\frac{k_2^2}{k_2^2 - \omega_{10}^2} + \frac{k_2^2}{\omega_{20}^2 - k_2^2} \right) + \zeta k_2 \left(\alpha_2 \frac{\omega_{10}^2}{k_2^2 - \omega_{10}^2} + \alpha_1 \frac{\omega_{20}^2}{\omega_{20}^2 - k_2^2} \right) > 0, \\ 4\omega_{10}\omega_{20} \left(\frac{k_2^2}{\omega_{20}^2 - k_2^2} \xi k_1 + \alpha_2 \zeta k_2 \frac{\omega_{10}^2}{k_2^2 - \omega_{10}^2} \right) \left(\frac{k_2^2}{k_2^2 - \omega_{10}^2} \xi k_1 + \right. \\ \left. + \alpha_1 \zeta k_2 \frac{\omega_{20}^2}{\omega_{20}^2 - k_2^2} \right) > \frac{(k_1 k_2)^4}{(k_2^2 - \omega_{10}^2)(\omega_{20}^2 - k_2^2)} r_{y0}. \end{aligned}$$

The first condition is almost always fulfilled. Nonfulfillment of the second condition means the presence of unstable solutions. If damping in the vibration insulator is very small ($\zeta = 0$), the second inequality assumes a rather simple form

$$r_{y0} < 2 \frac{\sqrt{\omega_{10}\omega_{20}}}{k_1} \xi. \quad (17)$$

Since $\omega_{10} < \omega_{20}$, inequality (17) is not fulfilled at smaller values of r_{y0} than inequality (12), and accordingly the unstable vibrations at frequency $\Omega = \omega_{10} + \omega_{20}$ occur at smaller values of the amplitude of vibration acceleration of the base than at frequency $\Omega = 2\omega_{20}$.

Analysis shows that a pendulum, vibration-insulated in the horizontal plane, can make unstable parametric vibrations upon vertical vibration of the base. When vibration insulators with small damping are used, the stability of vibrations can be guaranteed by selecting the appropriate damping coefficient in the pendulum.

BIBLIOGRAPHY

1. "Osnovy teorii kolebaniy" [Fundamentals of Vibration Theory], edited by V. V. Migulin, Moscow, 1978.
2. Ganiyev, R. F. and V. O. Kononenko, "Kolebaniya tverdykh tel" [Vibrations of Solids], Moscow, 1976.

UDC 531.383

GYROSCOPIC EFFECT IN SURFACE ACOUSTIC WAVES

907F0290N Kiev MEKHANIKA GIROSKOPICHESKIKH SISTEM in Russian, Issue 8, 1989 (manuscript received 10 Oct 87) pp 62-65

[Article by S. A. Sarapulov, candidate of technical sciences, and S. P. Kisilenko, junior scientific associate, Kiev Polytechnical Institute]

[Text] The effect of uniform rotation of the base on evolution of the surface acoustic wave (PAV) and the possibility of developing a miniature angular velocity meter are considered in this article.

Substrates, which have anisotropic elastic properties, are ordinarily used in converters based on PAV. But since the piezoelectric effect is only a small perturbation of the considered wave, which is primarily mechanical in nature [1], let us study the propagation of the wave along an isotropic substrate to simplify further computations, without disturbing the qualitative pattern of dynamics of the PAV.

According to Newton's third law, the equations of motion of the PAV are presented in the form

$$\rho \frac{\partial^2 u_i}{\partial t^2} - c_{inkl} \frac{\partial^2 u_k}{\partial x_n \partial x_l} + 2\rho \epsilon_{ink} \Omega_n \frac{\partial u_k}{\partial t} + \rho (\Omega_i \Omega_k u_k - \Omega_n^2 u_i) = 0 \quad (1)$$

$(i, n, k, l = \overline{1, 3}),$

where ρ is the density of the substrate material, c_{inkl} is the tensor of the elastic constants, ϵ_{ink} is Levy-Chivit density, $\Omega = \{\Omega_1, \Omega_2, \Omega_3\}$ is the angular velocity vector, $u = \{u_1, u_2, u_3\}$ is the elastic displacement vector, and $x_1 x_2 x_3$ is a Cartesian coordinate system.

The circular frequency of the PAV ω is ordinarily much greater than angular velocity Ω . Therefore, the third term of equation (1), which characterizes the Coriolis force of inertia, is on the order of smallness $\delta = \Omega/\omega \ll 1$, while the first term that describes centrifugal forces is on the order of δ^2 . Let us further disregard consideration of

the effect of the centrifugal term of equation (1) on the dynamics of the PAV because of its smallness.

Let us represent the generating solution of system (1) by the expression

$$u_i = \alpha_i \exp [jk(b_i x_i - vt)], \quad (2)$$

where α_i is amplitude, v is the phase velocity of wave propagation, $k = \omega/v$ is the wave number, and b_i are direction cosines, corresponding to Cartesian axes x_i .

Let the surface wave be propagated along axis x_1 and be attenuated along axis x_3 . Then, according to [1], $b_1 = 1$, $b_2 = 0$, and $b_3 = b$ at the selected orientation of propagation of the PAV. The value kb characterizes the depth of penetration of the surface wave into the substrate.

After substituting solution (2) into system (1), we reduce it to the following form:

$$\left(\Gamma_{ii} - \delta_{ii} \rho v^2 - 2j\rho \frac{v}{k} \varepsilon_{inl} \Omega_n \right) \alpha_i = 0, \quad (3)$$

where $\Gamma_{ii} = \Gamma_{ii} = b_k b_n c_{inhl}$ is a Kristoffel tensor and δ_{ij} is a Kronecker symbol.

When a PAV is propagating in an isotropic substrate c_{inhl} , there are only two independent components $c_{11} = \lambda + 2\mu$ and $c_{44} = \mu$, where λ and μ are elastic constants (Lame parameters) of the medium. The constraints imposed by symmetry on the tensor of elastic constants results in the following expression:

$$\Gamma_{ii} = \begin{Bmatrix} c_{11} + c_{44}b^2 & 0 & (c_{11} - c_{44})b^2 \\ 0 & c_{44}(1 + b^2) & 0 \\ (c_{11} - c_{44})b^2 & 0 & c_{44} + c_{11}b^2 \end{Bmatrix}.$$

Let us consider the characteristic equation of system (3)

$$(v_i^2 + v_i^2 b^2 - v^2)(v_i^2 + v_i^2 b^2 - v^2) - (v_i^2 - v_i^2)^2 b^2 - 4\delta^2 v^4 = 0 \quad (4)$$

as an algebraic equation with respect to b at given value of v . In equation (4), $v_l = (c_{11}/\rho)^{1/2}$, $v_t = (c_{44}/\rho)^{1/2}$ are the phase velocities of the longitudinal and transverse waves, respectively.

It follows from the necessary condition of approach of the amplitude of the PAV to zero at $x_3 \rightarrow \infty$ that b is the root of the characteristic equation (4), lying in the lower half-plane, solving which by the perturbation method [2] with accuracy up to $\sigma(\delta^3)$, we find

$$b^{(1)} = b^{(2)} = -j \left(1 - \frac{v^2}{v_l^2} - \sigma \right)^{1/2},$$

$$b^{(3)} = -j \left(1 - \frac{v^2}{v_t^2} + \sigma \right)^{1/2},$$

where $\sigma = \frac{4\delta^2 v^2}{v_l^2 - v_t^2}$.

Thus, the PAV is a linear combination of three partial waves:

$$u_i = \sum_{n=1}^3 C_n \alpha_i^{(n)} \exp [jk(b_i^{(n)} x_l - vt)], \quad (5)$$

where C_n are the amplitudes of the partial waves and $\alpha_i^{(n)}$ are the polarization coefficients of the components of the partial wave, determined from system (3).

Let us use the boundary conditions on the free surface of the substrate to find the phase velocity of the surface wave:

$$T_{3m} = c_{3mhl} \frac{\partial u_h}{\partial x_l} \quad \text{at } x_3 = 0, \quad (6)$$

where T is the stress tensor.

Having substituted solution (5) into boundary condition (6), we find

$$d_{in} C_n = 0, \quad (7)$$

where $d_{in} = c_{3mhl} \alpha_k^{(n)} b_l^{(n)}$.

The condition of nontriviality of solution of expression (7)

$$\det |d_{in}| = 0 \quad (8)$$

is considered as an implicit equation with respect to v .

At $\Omega = 0$, equation (8) is transformed to the form

$$\left(2 - \frac{v_0^2}{v_t^2}\right)^2 = 4 \left[\left(1 - \frac{v_0^2}{v_t^2}\right) \left(1 - \frac{v_0^2}{v_t^2}\right) \right]^{1/2},$$

where v_0 is the phase propagation velocity of the PAV with a fixed base. This wave is Rayleigh and its phase velocity can be approximated by the expression [3]

$$v_0 \approx \frac{0,72 - \xi^2}{0,75 - \xi^2}, \quad \xi = \frac{v_t}{v_l}.$$

If $\Omega \neq 0$, then, solving equation (8) with accuracy up to $o(\delta^2)$ by the perturbation method, we find $v = v_0 + \Delta v = (1 + a\delta)v_0$, where

$$a = \frac{a_1}{2a_2}, \quad a_1 = \frac{(1 - 2\xi^2)^2 - \xi^2 [(1 - \eta^2)(1 - \eta^2\xi^2)]^{1/2}}{(1 - \eta^2\xi^2)(1 - \xi^2)},$$

$$a_2 = \frac{1 + \xi^2 - 2\eta^2\xi^2}{[(1 - \eta^2)(1 - \eta^2\xi^2)]^{1/2}} - (2 - \eta^2)^{1/2}, \quad \eta = \frac{v_0}{v_t}.$$

Since the maximum value of ξ of a real isotropic solid is 0.5, then $0.87 < \eta < 0.96$ and accordingly $a \approx 2.4$.

It was established as a result of studies that there are slight changes (on the order of δ^2) of the direction cosines $b^{(n)}$ to the value

$$\Delta b^{(1)} = \Delta b^{(2)} = \frac{1}{2} (1 - \eta^2)^{-1/2} \sigma, \quad \Delta b^{(3)} = -\frac{1}{2} (1 - \eta^2\xi^2)^{-1/2} \sigma$$
 upon rotation of the

substrate at angular velocity Ω and there are changes of the phase propagation velocity of the PAV v_0 , proportional to δ , by the value

$$\Delta v = a \frac{v_0}{\omega} \Omega. \quad (9)$$

As follows from [4, 5], there is a correlation between variation of the phase propagation velocity of the PAV Δv , on the one hand, and the frequency of the autogenerators and phase signal of the delay lines and filters on the PAV, on the other hand, which is described by the following relations:

$$\frac{\Delta f}{f_0} = -\frac{\Delta \Phi}{\Phi_0} = \frac{\Delta v}{v_0}, \quad (10)$$

where f_0 and Φ_0 are the autogenerator frequency and phase of the signal of the delay line or filter on the PAV at $v = v_0$ and Δf and $\Delta \Phi$ are variation of the frequency and phase, determined by Δv .

After substitution of expression (9) into relation (10), we find

$$\Delta f = \frac{a}{2\pi} \Omega, \quad \Delta \Phi = -\frac{aL}{v_0} \Omega,$$

where L is the length of the operating section of propagation of the PAV.

Accordingly, rotation of the base results in variation of the autogenerator frequency and phase of the delay lines and filters on the PAV. Thus, $L = 2 \cdot 10^{-2}$ m, $v_0 = 5 \cdot 10^3$ m/s, $\Delta f = 2.9 \cdot 10^{-9}$ Hz, and $\Delta \Phi = 4.6 \cdot 10^{-13}$ rad at $\Omega = 10^{-2}$ °/hr.

Thus, there are physical prerequisites for development of low-accuracy miniature angular velocity meters that use a PAV, with frequency or phase outcome. We note in conclusion that the sensitivity of these inertial data converters with the frequency layout is dependent only on the elastic constants of the substrate, while that with the phase layout is also dependent on its dimensions.

BIBLIOGRAPHY

1. Oliner, A., "Poverkhnostnyye akusticheskiye volny" [Surface Acoustic Waves], Moscow, 1981.
2. Nayfe, A., "Vvedeniye v metody vozmushcheniy" [Introduction to Perturbation Methods], Moscow, 1984.
3. Viktorov, I. A., "Zvukovyye poverkhnostnyye volny v tverdykh telakh" [Acoustic Surface Waves in Solids], Moscow, 1981.

4. Kuleshov, V. V., P. F. Pizik, and V. I. Rebrov, "Semiconductor Converter Using Surface Acoustic Waves," "Dinamika elektromekhanicheskikh sistem" [The Dynamics of Electromechanical Systems], Tula, 1978.
5. Kuleshov, V. V., P. F. Pizik, and V. I. Rebrov, "Semiconductor Accelerometer Using Surface Acoustic Waves," "Dolgovremennaya stabilnost gravitatsionnykh priborov" [Long-Term Stability of Gravitational Devices], Moscow, 1979.

UDC 513.36:681.3.06

COMPUTER STUDY OF DRIFT OF CUSHIONED GYROSCOPE UPON ANGULAR VIBRATION OF BASE

907F02900 Kiev MEKHANIKA GIROSKOPICHESKIKH SISTEM in Russian, Issue 8, 1989 (manuscript received 21 Oct 87) pp 65-70

[Article by S. Ya. Svistunov, candidate of technical sciences, and Ye. V. Semikina, junior scientific associate, Kiev Polytechnical Institute]

[Text] Known specialized applications program packages for analysis of the dynamics of mechanical devices [1, 2] may not be used to design gyroscopic devices with regard to a real vibration-insulation system and the complex control circuit, which is ordinarily nonmechanical. This is caused by the constraint on the relationships on bodies in the Lagrange method of second kind, selected as the basic method for formulation of the equations of motion.

This disadvantage can be overcome in the MIT-1 applications program package, which constructs a mathematical model based on general theorems of dynamics with representation of the device in the form of an oriented graph of relationships [3]. The general diagram of the proposed package is shown in Figure 1. The MIT-1 package permits one to formulate symbolic nonlinear differential equations of motion of a gyroscope and to solve them by using numerical methods.

The input data for design are data on the structure of the device, the layout of shock absorbers and their parameters, the inertia-mass characteristics of the bodies making up the device, and the moments and forces acting on the components of the device. This information is represented in the form of operators of a specialized description language. This language is outlined in more detail in [4].

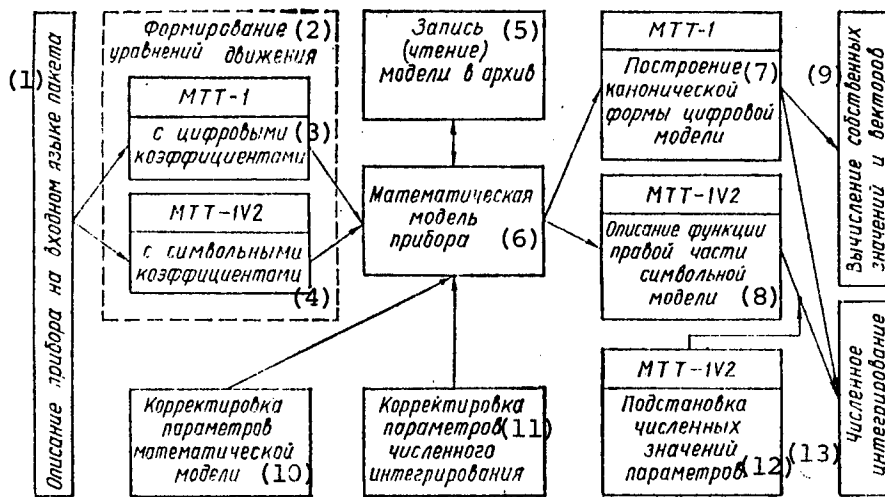

Figure 1

KEY:

1. Description of device in input language of package
2. Formulation of equations of motion
3. With digital coefficients
4. With symbolic coefficients
5. Write (read) model to archive
6. Mathematical model of device
7. Construction of canonical form of digital model
8. Description of function of right side of symbolic model
9. Calculation of eigen-values and vectors
10. Correction of parameters of mathematical model
11. Correction of parameters of numerical integration
12. Substitution of numerical values of parameters
13. Numerical integration

The mathematical model of the device, which has the following form, is formulated from this description

$$M\ddot{X} + N\dot{X} + KX = Df(t) + QP(t, X, \dot{X}) + F_1(t, X, \dot{X}, \ddot{X}) + F_2(t, X, \dot{X}, \ddot{X}), \quad (1)$$

where $M[n, n]$, $N[n, n]$, $K[n, n]$, $D[n, m]$, $Q[n, m_1]$ are matrices with symbolic or symbolic-digital coefficients, $X[n]$ is the vector of variables, $f(t)$ is the vector of external perturbation, acting on the body from the direction of the base, $P(t, X, \dot{X})$ is the vector of control, external moments and forces, and $F_1(t, X, \dot{X}, \ddot{X})$, and $F_2(t, X, \dot{X}, \ddot{X})$ are nonlinear

functions that contain paired and triple products of variables, their derivatives and external perturbation with symbolic or symbolic-digital coefficients.

This type of mathematical model is related to the fact that expansion of the matrices of direction cosines with grouping of terms by orders of smallness into a series is fulfilled automatically during formulation of the equations.

Selection of linearized equations as the main equations for design is related to the need to study the dynamics of complex gyroscopic devices with small computer resources.

Special procedures of analytical transformations above power series of the following type (the MIT-1 package) were worked out to construct an algorithm for formulation of the equations

$$L = \sum_{i=1}^n k_i \alpha_j^i \beta_k^i \gamma_s^i p,$$

where k_i is a digital coefficient, α_j , β_k , and γ_s are variables and the first and second derivatives, and $p = 0, 1, 2$ is the exponent.

The procedures of analytical transformations were subsequently modified (the MIT-1V2 package) for the case when

$$k_i = k'_i \prod_{q=1}^3 Q_q,$$

where k'_i is a digital coefficient, and Q_q are symbolic parameters that describe the inertial-mass characteristics of bodies. The MIT-1V2 package exceeds the first version of MIT-1 in its capabilities, but is considerably inferior in speed.

Retention of two similar program systems for formulation of the equations is related to the need to solve two design problems: selection of the parameters of the device and design of an optimal vibration-insulation system for a given device. In the first case, symbolic equations of motion must be compiled for determining the dependence of the coefficients in (1) on the parameters of the device. The MIT-1V2 package fulfills this. In the second case, with known digital parameters of the device, one must analyze the different layouts of the shock absorbers, one must select their parameters, and one must change the law of external vibration. The MIT-1V2 package can also solve this problem, but as experience shows, it is preferable to use MIT-1, which operates two-threefold faster.

Consideration of the interaction between bodies is the most original part of the package.

There are no constraints on the type of links in the formulation algorithm, and they are taken into account by substitution of codes of the moments and forces into the corresponding projections of the equations. A specific mathematical expression of the moments and forces is contained in special matrices or is formulated automatically by the package for description of the device. These expressions are substituted into the equations at the stage of constructing the canonical forms. This permitted one to work out special procedures of correcting the parameters of the mathematical model without changing the equations of motion. The parameters to be corrected include coordinates of the points of attachment of the shock absorbers, the coefficients of stiffness and damping of the shock absorbers, and external perturbations.

| (1) Элемент прибора | (2) $I_x, 10^{-6} \text{ Н}\cdot\text{м}^2$ | $I_y, 10^{-6} \text{ Н}\cdot\text{м}^2$ | $I_z, 10^{-6} \text{ Н}\cdot\text{м}^2$ |
|------------------------|--|---|---|
| (3) Корпус | 6,5 | 6,5 | 7,0 |
| (4) Наружная рамка | 3,7 | 3,4 | 3,6 |
| (5) Кожух гироскопа | 1,9 | 2,5 | 2,4 |
| (6) Ротор | 1,4 | 1,4 | 1,0 |

KEY:

- | | |
|------------------------------|------------------------|
| 1. Component of device | 4. Outer gimbal |
| 2. $\text{N}\cdot\text{m}^2$ | 5. Housing of gyrounit |
| 3. Body | 6. Rotor |

A canonical form of the following type is constructed from the generated equations

$$\dot{Y} = F(Y, t), \quad (2)$$

where Y is a vector of the variables of state of the system. An accurate expression of function F(Y, t) can be found for equations with digital coefficients. It is formulated in the MTT-1V2 package by a special algorithm at each step of numerical integration.

System of equations (2) is subsequently solved by using numerical methods, which are selected automatically by control operators, which are a constituent part of the data preparation language.

The MTT-1 package and its second version MTT-1V2 perform the entire cycle of study of the mathematical model from its formulation by description of the device to numerical solution on a computer. This

permits the designer, changing the study control operators, to conduct various numerical experiments with a mathematical model of the device.

The dynamics of a cushioned gyroscope with angular vibration of the base with regard to the real vibration-insulation system is studied in this article by using the MTT-1 package. A gyroscope in a gimbal suspension, mounted on spring absorbers, was selected as the object of study. Let us solve the classical problem of estimating the efficiency of the vibration-insulation system under resonance conditions. Analytical solution of a similar problem is given in [5, 6], which permits one to present comparative estimates.

A layout of a gyroscope in a gimbal suspension and the orientation of the axes of the coordinate system correspond to that adopted in [6]. We assume that the axes of all the coordinate systems are the main axes of inertia of their own bodies, the origins of all the systems coincide in the initial position, and the inner gimbal is rotated by 30° about its own axis. The moments of inertia with respect to their own axes are presented in the table. The natural moment of momentum of the rotor is equal to $5.4 \cdot 10^{-3} \text{ N}\cdot\text{m}\cdot\text{s}$. The overall dimensions of the gyroscope are $0.1 \times 0.1 \text{ m}$ and the axial stiffness of the springs is $C_i = 1,617.7 \text{ N/m}$ ($i = \overline{1, 4}$). Damping moments with coefficients $9.8 \cdot 10^{-6} \text{ N}\cdot\text{m}\cdot\text{s}$ act along the axes of the suspension.

Let us consider the motion of the body only along axis z . The dampened coefficient along this axis is equal to $1.1765 \cdot 10^{-3} \text{ N}\cdot\text{m}\cdot\text{s}$.

Let us compile complete nonlinear equations of motion of a gyroscope with regard to the nonlinearities up to third order of smallness inclusively, which are recorded in the archive. Using the method of step analysis of the mathematical model, realized in the package, let us increase the complexity of the model for the entire cycle of studies.

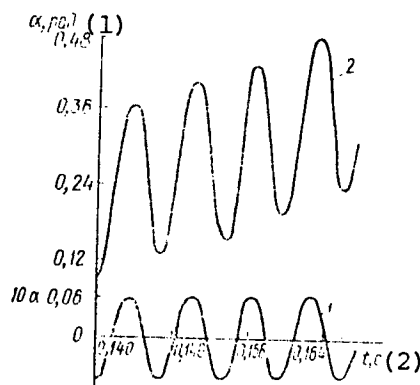

Figure 2

KEY:

1. rad

2. s

We find the frequencies of natural vibrations of the system in the first step by the linear model (it is found from general model (1) by eliminating part of the terms and this exclusion is performed automatically. With the selected input data, $\nu_1 = 208.12 \text{ s}^{-1}$ and $\nu_2 = 1,033.67 \text{ s}^{-1}$.

Let us determine the amplitude of the angular vibration velocity of the outer gimbal of a cushioned gyroscope with main resonance at frequency ν_2 . Let us first give the perturbation along axis z in the form $\theta_z = 4 \sin(1,033.67 t)$ using the correction section. Integrating the linear system of equations by the graphs which are constructed automatically, we find the desired value: $A \cong 10 \text{ s}^{-1}$, which is in good agreement with the results of analytical calculation performed by the formulas of [6].

The last step in analysis of a cushioned gyroscope is solution of the complete system of equations with nonlinearities up to third order of smallness inclusively. The results of the calculation are presented in Figure 2 (curve 1).

The equations of a rigidly mounted gyroscope with the same law of perturbation of the base must be formulated to analyze the efficiency of the cushioning system. We should compile a similar task for a design, having taken from it a description the flexible elements. By integrating the linear system of equations, we determine the amplitude of the angular vibration velocity of the outer gimbal: $A_2 = 310 \text{ s}^{-1}$. The results of integrating the nonlinear equations are presented by curve 2 in Figure 2. Calculations show that the drift of a cushioned gyroscope is much less than that of a rigidly attached gyroscope. It is essentially invisible at the selected scale. The ratio between the drift of gyroscopes mounted rigidly and on cushions coincides with that presented in [6].

The use of the MIT-1 package for study of the drift of a cushioned gyroscope considerably reduces the analysis time.

BIBLIOGRAPHY

1. Grosheva, M. V., G. B. Yefimov, V. A. Brumerger et al., "Sistemy analiticheskikh vychisleniy na EVM (Analiticheskiye pakety prikladnykh programm)" [Systems for Analytical Computations on the Computer (Analytical Applications Program Packages), Moscow, 1983 (Preprint No 1, Institute of Mechanics, USSR Academy of Sciences).
2. Solnitsev, R. I., I. V. Kovtun, and A. S. Presnyak, "Instrument System of Designing the Linguistic Support of a CAD System," EVM V PROYEKTIROVANII I PROIZVODSTVE, No 3, 1985.

3. Svistunov, S. Ya. and Ye. V. Semikina, "Paket prikladnykh programm 'MTT-1.' Rasshireniye funktsionalnykh vozmozhnostey" [The MTT-1 Applications Program Package. Expansion of the Functional Capabilities], Kiev, 1986. Deposited at UkrNIINTI No 1163, 30 Apr 86.
4. Marosin, O. P. and S. Ya. Svistunov, "Language for Describing Complex Mechanical Systems With Flexible Couplings," MEKHANIKA GIROSKOPICHESKIKH SISTEM, No 2, 1983.
5. Pavlovskiy, M. A., "Drift of Cushioned Gyroscope Upon Angular Vibration of Base," PRIKLADNAYA MEKHANIKA, No 5, 1975.
6. Ryzhkov, L. M. and A. A. Maystruk, "Efficiency of Small Gyroscope Cushioning Systems With Angular Vibration of Base," MEKHANIKA GIROSKOPICHESKIKH SISTEM, No 1, 1982.

UDC 531.383

ON AZIMUTH MOTION OF PENDULUM GYROCOMPASS DURING EXPONENTIAL
ACCELERATION OF ITS ROTOR

907F0290P Kiev MEKHANIKA GIROSKOPICHESKIKH SISTEM in Russian, Issue 8,
1989 (manuscript received 31 Oct 87) pp 70-74

[Article by V. N. Fedorov, candidate of technical sciences, Kiev
Polytechnical Institute]

[Text] It was assumed during study of the azimuth motion of a ground-based pendulum gyrocompass (MGK) during acceleration of its rotor [1-3] that the angular momentum of the sensitive element (ChE) increases by linear law. Linear law can be realized rather simply in the presence of a controlled drive of the gyromotor. The dependence of the angular momentum on time in the case of uncontrolled acceleration is linear only during the initial segment of the acceleration curve [4]. The azimuth motion of the sensitive element of a pendulum gyrocompass is considered in this article with exponential law of variation of the moment of momentum, which describes the process on the entire section of the uncontrolled acceleration. The constant M_0 and linear time-dependent $M_1 t$ uncontrolled moments with respect to the vertical axis of the sensitive element are taken as perturbations.

The system of precession equations that describe the motion of the principle axis of the MGK at small angles of deflection from the plane of the meridian has the following form upon variation of the angular momentum

$$\begin{aligned} H\dot{\alpha} + HU_2 + (mgl + HU_1)\beta &= 0, \\ H\dot{\beta} + H\dot{\beta} - HU_1\alpha &= M_0 + M_1 t, \end{aligned} \quad (1)$$

where H is the angular momentum of the gyroscope, mgl is the pendulosity of the instrument, U_1 and U_2 are the horizontal and vertical components of the earth's angular rotational velocity, respectively, α and β are the angles of rotation of the sensitive element of the MGK in azimuth and in the vertical plane, and t is current time.

It is easy to find from system of equations (1) the equation of motion of the sensitive element with respect to the azimuth coordinate. With regard to $mg l \gg H U_1$, it has the form

$$H\ddot{\alpha} + 2\dot{H}\dot{\alpha} + mg l U_1 \alpha = -2\dot{H}U_2 - M_0 \frac{mg l}{H} - M_1 t \frac{mg l}{H}. \quad (2)$$

Let the angular momentum vary by the law $H = H_m - (H_m - H_0)e^{-\lambda t}$, where H_0 and H_m are the angular momentum at the beginning and end of acceleration and λ is the attenuation index of the exponential function.

Let us introduce independent variable $z = (1 - H_0 H_m^{-1})e^{-\lambda t}$ ($z(0) = z_0 = 1 - H_0 H_m^{-1}$). Denoting the derivatives of the desired function with respect to the new variable by α' and α'' , let us rewrite equation (2) as follows:

$$\begin{aligned} z^2(z-1)\alpha'' + z(3z-1)\alpha' - U_1 mg l \lambda^{-2} H_m^{-1} \alpha = \\ = 2U_2 \lambda^{-1} z + M_0 mg l \lambda^{-2} H_m^{-2} (1-z)^{-1} + \\ + M_1 mg l \lambda^{-3} H_m^{-2} (1-z)^{-1} \ln(z_0 z^{-1}). \end{aligned} \quad (3)$$

Assuming [5]

$$\alpha = z^{iV} \bar{r} U(z), \quad (4)$$

where $p = U_1 mg l \lambda^{-2} H_m^{-1}$ and i is an imaginary unit, let us write equation (3) in the form

$$\begin{aligned} z(z-1)U'' + [(2iV\bar{p} + 3)z - (2iV\bar{p} + 1)]U' + \\ + (2iV\bar{p} - p)U = 2U_2 \lambda^{-1} z^{-iV\bar{p}} + \\ + mg l \lambda^{-2} H_m^{-2} (M_0 + M_1 \lambda^{-1} \ln z_0) z^{-iV\bar{p}-1} (1-z)^{-1} - \\ - M_1 mg l \lambda^{-3} H_m^{-2} z^{-iV\bar{p}-1} (1-z)^{-1} \ln z. \end{aligned} \quad (5)$$

A homogeneous equation, corresponding to (5), is a hypergeometric equation (Gauss equation) and has the solution

$$U(z) = C_1 U_1(z) + C_2 U_2(z), \quad (6)$$

where C_1 and C_2 are arbitrary constants and $U_1(z) = F(a, b, c, z)$ and $U_2(z) = F(a-c+1, b-c+1, 2-c, z)$ are hypergeometric functions with parameters $a = i\sqrt{\rho}$; $b = i\sqrt{\rho} + 2$; $c = 2i\sqrt{\rho} + 1$.

The partial solution, found by using the method of variation of the arbitrary constants, can be written in the form

$$\begin{aligned}
 U_{\text{part}}(z) = & 2U_2\lambda^{-1} [U_1(z) Q_2(z) - U_2(z) Q_1(z)] + \\
 & + mg\lambda^{-2} H_m^{-2} (M_0 + M_1\lambda^{-1} \ln z_0) [U_1(z) R_2(z) - U_2(z) R_1(z)] - \\
 & - M_1 mg\lambda^{-3} H_m^2 [U_1(z) S_2(z) - U_2(z) S_1(z)],
 \end{aligned} \tag{7}$$

where

$$\begin{aligned}
 Q_{1,2}(z) = & \int \frac{U_{1,2}(z) dz}{z^{1+a} (1-z) \Delta(z)}; \quad R_{1,2}(z) = \int \frac{U_{1,2}(z) dz}{z^b (1-z)^2 \Delta(z)}; \\
 S_{1,2}(z) = & \int \frac{\ln z U_{1,2}(z) dz}{z^b (1-z)^2 \Delta(z)}; \quad \Delta(z) = (1-c) z^{-1} (1-z)^{c-a-b-1}.
 \end{aligned} \tag{8}$$

The general solution of equation (5) consists of the sum of the solution of the homogeneous equation, shown in the form of (6), and of partial solution (7). Integration constants C_1 and C_2 are determined with the initial conditions

$$z = z_0: U(z_0) = U_0; U'(z_0) = U'_0. \tag{9}$$

After simple transformations, the solution of equation (5) can be written as follows:

$$\begin{aligned}
 U(z) = & U_0 \Delta^{-1}(z_0) [U'_2(z_0) U_1(z) - U'_1(z_0) U_2(z)] - \\
 & - U'_0 \Delta^{-1}(z_0) [U_2(z_0) U_1(z) - U_1(z_0) U_2(z)] + \\
 & + 2U_2\lambda^{-1} [Q_2(z_0, z) U_1(z) - Q_1(z_0, z) U_2(z)] + \\
 & + mg\lambda^{-2} H_m^{-2} (M_0 + M_1\lambda^{-1} \ln z_0) [R_2(z_0, z) U_1(z) - \\
 & - R_1(z_0, z) U_2(z)] - M_1 mg\lambda^{-3} H_m^2 [S_2(z_0, z) U_1(z) - S_1(z_0, z) U_2(z)],
 \end{aligned} \tag{10}$$

where $Q_{1,2}(z_0, z)$, $R_{1,2}(z_0, z)$, $S_{1,2}(z_0, z)$ are integrals of type (8) with integration limits z_0 and z .

Having determined on the basis of expression (4) the analytical correlation between (9) and initial conditions $a(0) = a_0$ and $\beta(0) = \beta_0$ of system of equations (1)

$$U_0 = \alpha_0 z_0^{-a}, \quad U'_0 = \left[\frac{mgI\beta_0}{H_m \lambda (1-z_0)} + \frac{U_2}{\lambda} - a\alpha_0 \right] z_0^{-(1+a)},$$

let us write the desired solution of equation of motion (3) of the sensitive element with respect to the azimuth coordinate in the form

$$\begin{aligned} \alpha(z) = & \alpha_0 z^a z_0^{-a} \Delta^{-1}(z_0) [U'_2(z_0) U_1(z) - U'_1(z_0) U_2(z)] + \\ & + 2U_2 \lambda^{-1} z^a [U_1(z) Q_2(z_0, z) - U_2(z) Q_1(z_0, z)] - \\ & - \left(\frac{z}{z_0}\right)^a \frac{1}{z_0 \Delta(z_0)} \left[\frac{mgI\beta_0}{H_m \lambda (1-z_0)} + \frac{U_2}{\lambda} - a\alpha_0 \right] \times \\ & \times [U_2(z_0) U_1(z) - U_1(z_0) U_2(z)] + \\ & + \frac{mgIz^a}{\lambda^2 H_m^2} \left(M_0 + \frac{M_1}{\lambda} \ln z_0 \right) [U_1(z) R_2(z_0, z) - U_2(z) R_1(z_0, z)] - \\ & - M_1 mgIz^a \lambda^{-3} H_m^{-2} [U_1(z) S_2(z_0, z) - U_2(z) S_1(z_0, z)]. \end{aligned}$$

The expansions of the hypergeometric functions and the integrals from them, for example, with respect to Chebyshev polynomials [6] and also direct integration of the equations of motion on a computer can be used upon numerical study of the motion of the MGK in the mode of an exponential increase of the moment of momentum.

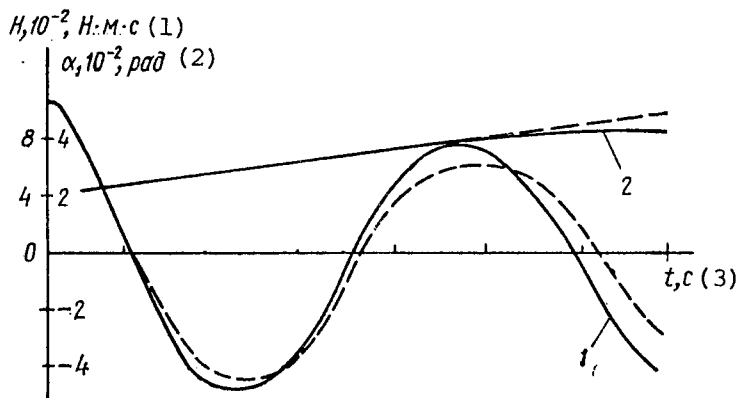

KEY:

- 1. N·m·s
- 2. rad

3. s

The results of integration of system of equations (1) at $mg_1 = 2 \cdot 10^4$ $g \cdot cm \cdot s$, $U_1 = U_2 = 5.161 \cdot 10^{-5} s^{-1}$, $\beta(0) = 2.58 \cdot 10^{-5} rad$, $\alpha(0) = 5.2 \cdot 10^{-2} rad$, $M_0 = 1.5 \cdot 10^{-4} g \cdot cm$, and $M_1 = 2.5 \cdot 10^{-7} g \cdot cm \cdot s^{-1}$ in the interval $t = 0-700 s$ are presented in the figure. Solid curve 1 shows the dependence of the angle of rotation of the sensitive element at azimuth on time in the case when the angular momentum varies by exponential law (curve 2). The dashed curves show similar functions ($\alpha = \alpha(t)$ and $\tilde{H} = H(t)$) for the same initial conditions and perturbations when observing condition $h = (H_m - H_0)\lambda$, where λ is the characteristic slope of acceleration of the rotor in acceleration law $H = H_0 + ht$.

It follows from the figure that the functions found in [1-3] can be used on the initial leg of the acceleration curve where it is described rather well by a linear function, upon study of the azimuth motion of the sensitive element of the MCK. The entire leg of the exponential acceleration of the rotor is determined analytically by expression (10) of this article.

BIBLIOGRAPHY

1. Gleyzer, V. I., "Programmed Control of Angular Momentum of Gyrocompass," IZVESTIYA LENINGRADSKOGO ELEKTROTEKHNICHESKOGO INSTITUTA, No 152, 1974.
2. Gleyzer, V. I. and Yu. S. Lukovatyy, "Synthesis of an Optimal Program for Acceleration of the Rotor of a Ground-Based Pendulum Gyrocompass," IZVESTIYA VUZOV. PRIBOROSTROYENIYA, Vol 19, No 9, 1976.
3. Kargu, L. I., Yu. S. Lukovatyy, and V. A. Yablonskaya, "Accelerated Reduction of Ground-Based Gyrocompass With Linear Law of Acceleration of Rotor," Loc. cit., Vol 17, No 5, 1974.
4. Pavlov, V. A., "Osnovy proyektirovaniya i rascheta girokopicheskikh priborov" [Fundamentals of Design and Calculation of Gyroscopic Devices], Leningrad, 1967.
5. Kamke, E., "Spravochnik po obyknovennym differentsialnym uravneniyam" [Handbook on Ordinary Differential Equations], Moscow, 1976.
6. Lyuk, Yu., "Spetsialnyye matematicheskiye funktsii i ikh approksimatsii" [Special Mathematical Functions and Their Approximations], Moscow, 1980.

UDC 517.9+518.6

CONSTRUCTION OF DISCRETE MODEL OF MOTION OF SOLID IN FLEXIBLE SUSPENSION

907F0290Q Kiev MEKHANIKA GIROSKOPICHESKIKH SISTEM in Russian, Issue 8, 1989 (manuscript received 11 Nov 87) pp 74-80

[Article by A. S. Apostlyuk, candidate of technical sciences, and V. N. Sheludko, candidate of technical sciences, Kiev Polytechnical Institute]

[Text] Those numerical methods which permit one to integrate the equations of motion at a high rate can be used to construct effective discrete models of motion of mechanical systems, and the requirement of high integration accuracy is not compulsory for these methods.

Let us construct a discrete model of motion of a mechanical system, consisting of an absolute solid, connected to base N by shock absorbers. Each shock absorber is represented in the form of three mutually perpendicular elementary springs, articulately attached to the base (see figure). Following [1], let us assume that the springs are arranged along the principal directions at any moment of time, and that displacement of the body, perpendicular to the axis of this spring, does not alter its reactions.

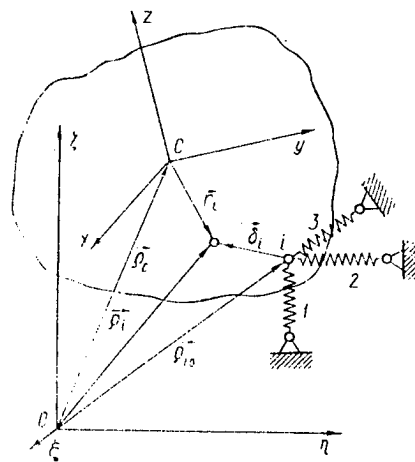

Let us introduce the conditionally fixed coordinate system $O\xi\eta\zeta$ and $Cxyz$, invariably bound to the body, and the origin C of coordinate system $Cxyz$ is compatible with the center of mass of the body, while axes Cx , Cy and Cz will be considered its principal central axes of inertia. Let both coordinate systems coincide at the initial moment of time. Let us denote by α_{ij} , β_{ij} , and γ_{ij} the cosines of the angles formed by the axis of the j -th spring ($j = 1, 2, 3$) of the i -th shock absorber according to axes $O\xi$, $O\eta$, and $O\zeta$. Let us select coordinates ξ , η , ζ that characterize the translational motion of the body with respect to the base and Euler angles ψ , θ , φ that describe the rotation of the body about the center of mass as the generalized coordinates.

In this case, the law of motion of the solid in the flexible suspension can be determined by using Newton's second law and Euler-Poisson equations:

$$\begin{aligned}
 m\ddot{\xi} &= F_1; \quad m\ddot{\eta} = F_2; \quad m\ddot{\zeta} = F_3; \\
 I_1\dot{\omega}_x - (I_2 - I_3)\omega_y\omega_z &= M'_1; \quad I_2\dot{\omega}_y - (I_3 - I_1)\omega_z\omega_x = M'_2; \\
 I_3\dot{\omega}_z - (I_1 - I_2)\omega_x\omega_y &= M'_3; \\
 \dot{\psi} &= \frac{\sin \varphi}{\sin \theta} \omega_x + \frac{\cos \varphi}{\sin \theta} \omega_y; \quad \dot{\theta} = \cos \varphi \omega_x - \sin \varphi \omega_y; \\
 \dot{\varphi} &= -\sin \varphi \operatorname{ctg} \theta \omega_x - \cos \varphi \operatorname{ctg} \theta \omega_y + \omega_z,
 \end{aligned} \tag{1}$$

where m is the mass of the body, I_1 , I_2 , and I_3 are the moments of inertia of the body with respect to axes Cx , Cy , and Cz , respectively, $\ddot{\rho}_c = (\ddot{\xi}, \ddot{\eta}, \ddot{\zeta})$ is the vector of the absolute acceleration of the center of mass, F_1 , F_2 , and F_3 are the projections of the main vector of the external forces \vec{F} onto axes $O\xi$, $O\eta$, and $O\zeta$, and ω_x , ω_y , and ω_z and M'_1 , M'_2 , and M'_3 are projections of the vector of the instantaneous angular velocity $\vec{\omega}$ and of the principal moment of external forces \vec{M} onto the axes of fixed coordinate system $Cxyz$.

The principal vector \vec{F} is the geometric sum of reactions of the shock absorbers and of the gravity of the body, while the principal moment \vec{M} is the sum of moments of these forces with respect to the center of mass. The reaction R_i of the i -th shock absorber is a function (generally nonlinear) of deformation of u_i and of its first derivative

\dot{u}_i . Let us represent it in the form of [1] $R_i(u_i, \dot{u}_i) = F_i(u_i) + U_i(\dot{u}_i)$, where F_i is flexible and U_i is dissipative forces, and let us consider the order of calculation of the principal vector and of the principle moment in equations (1). If, for example, $F_{ij} = -k_{ij}u_{ij}$, $U_{ij} = 0$ ($i = 1, \dots, N$; $j = 1, 2, 3$), where k_{ij} is the stiffness coefficient of the j -th spring of the i -th shock absorber, then the principal vector can be determined in the following manner:

$$F = - \sum_{i=1}^N \sum_{j=1}^3 k_{ij} u_{ij}.$$

Assuming that the stiffness coefficients k_{ij} and coordinates x_i , y_i , and z_i of the points of attaching the shock absorbers to the body (the latter are invariable in the body-axes system $Cxyz$) are known, displacements $\vec{\delta}_i = (\delta_{i1}, \delta_{i2}, \delta_{i3})$ of these points with respect to the base is determined by vector equalities (see figure)

$$\vec{\delta}_i = \vec{\rho}_c + A\vec{r}_i - \vec{\rho}_{i0} \quad (i = 1, \dots, N), \quad (2)$$

where $\vec{\rho}_c = (\xi, \eta, \zeta)$ is displacement of the center of mass with respect to the base, $\vec{r}_i = (x_i, y_i, z_i)$ are the constant radius vectors of the points of attachment in coordinate system $Cxyz$, $\vec{\rho}_{i0} = (\xi_{i0}, \eta_{i0}, \zeta_{i0})$ are the radius vectors of the points of attachment at initial moment of time in coordinate system $O\xi\eta\zeta$, and A is the matrix of transition from coordinate system $O\xi\eta\zeta$ to $Cxyz$.

Deformation u_{ij} is equal to the scalar product of displacement $\vec{\delta}_i$ by unit vector $\vec{p}_{ij} = (\alpha_{ij}, \beta_{ij}, \gamma_{ij})$, directed along the axis of the spring: $u_{ij} = \vec{\delta}_i \vec{p}_{ij}$. Assuming that the principal directions of the shock absorbers are parallel to axes $O\xi$, $O\eta$, and $O\zeta$, we write the projections of the main vector F onto the axes of fixed coordinate system $O\xi\eta\zeta$

$$F_j = - \sum_{i=1}^N k_{ij} \delta_{ij} \quad (j = 1, 2, 3). \quad (3)$$

The expression

$$F'_{ij} = A^T F_{ij} \quad (4)$$

determines the elastic force of the ij-th spring (F'_{ij}) in coordinate system Cxyz (the superscript "T" denotes the transposition operation, while the prime indicates the assignment of the vector marked by it in the fixed coordinate system Cxyz). Finding the moment of this force with respect to the center of mass C by the formula

$$\vec{M}'_{ij} = \vec{r}_i \times \vec{F}'_{ij}, \quad (5)$$

we find the principal moment from the expression

$$\vec{M}' = \sum_{i=1}^N \sum_{j=1}^3 \vec{r}_i \times \vec{F}'_{ij}. \quad (6)$$

Having been given in one way or another the forces and moments of figuring in the right sides of equations (1), for example, by formulas (2)-(6), one can generally integrate equations (1), using any of the standard numerical methods of integration of the system of ordinary differential equations. However, this approach is hardly suitable in real-time simulation. It may be feasible to use difference approximation, based on the principles of discrete variational calculation [2, 3]. Let us assume that equations (1) can be written by Lagrange functions $L = T - \Pi$ (T and Π are the kinetic and potential energy, respectively), which is dependent on the generalized coordinates (their vector column q has the form $q^T = [\xi, \eta, \zeta, \psi, \theta, \varphi]$), on velocities \dot{q} and time t:

$$\frac{d}{dt} \left(\frac{\partial L}{\partial \dot{q}} \right) - \frac{\partial L}{\partial q} = 0. \quad (7)$$

It is known that equation (7) is a condition of the stationary state (of the approach of the first variation to zero) of the integral $\int_{t_1}^{t_2} L dt$ at the selected constant quantification step $h = (t_2 - t_1)/\nu$ (ν is the number of intervals), the integral can be approximated

$$\sum_{\mu=1}^{\nu} L(t_{\mu}, q_{\mu}, \dot{q}_{\mu}) h = \sum_{\mu=1}^{\nu} L_{\mu} h, \quad (8)$$

where t_{μ} is the moment of the end of the μ -th interval and q_{μ} is the value of the vector of generalized coordinates at this moment of time, while the vector of generalized velocities \dot{q}_{μ} is determined as follows:

$$\dot{q}_{\mu} = (q_{\mu} - q_{\mu-1})/h \quad (\mu = 1, \dots, \nu). \quad (9)$$

Sum (8) will approach symbol $\int_{t_1}^{t_2} L dt$ upon natural assumptions with respect to function L . Accordingly, a discrete analogue of (7), i.e., a difference relation that guarantees approach of the first variation of sum (8) to zero, will be the relation [2]

$$\frac{1}{h} \left(\frac{\partial L_{\mu+1}}{\partial \dot{q}_{\mu+1}} - \frac{\partial L_{\mu}}{\partial \dot{q}_{\mu}} \right) - \frac{\partial L_{\mu}}{\partial q_{\mu}} = 0, \quad \mu = 1, \dots, \nu, \quad (10)$$

which, together with formula (9), forms a discrete model of the dynamic system described by equation (7). Since the method of constructing the Lagrange functions for dissipative systems is sufficiently complicated (see, for example, [4]), the dispersion of energy in the system can be considered in the first approximation, having adopted the value $\exp(-nt)L$ as the Lagrange function, i.e., having approximated equations (1) by the following discrete expressions rather than by relations (10) [5]:

$$\frac{1}{h} \left(e^{nh} \frac{\partial L_{\mu+1}}{\partial \dot{q}_{\mu+1}} - \frac{\partial L_{\mu}}{\partial \dot{q}_{\mu}} \right) - \frac{\partial L_{\mu}}{\partial q_{\mu}} = 0, \quad (11)$$

where n is a parameter that characterizes the damping in the system.

Having used expressions (9) and (11), let us construct the desired discrete model of motion of a solid on a flexible suspension. To do this, let us determine sequentially the potential and kinetic energy of this mechanical system.

The potential energy of the system is: $\Pi = \Pi_F + \Pi_P$, where $\Pi_F =$
 $= \frac{1}{2} \sum_{i=1}^N \sum_{j=1}^3 k_{ij} u_{ij}^2$ is the potential energy of 3N deformed elementary springs
and $\Pi_P = mg\zeta$ is the potential energy of the body in a gravitational
field.

Let us consider this arrangement of the shock absorbers when the axes of
the springs are parallel to axes $O\xi$, $O\eta$, and $O\zeta$. Then

$$\frac{\partial \Pi}{\partial \xi} = \sum_{i=1}^N k_{i1} \delta_{i1}, \quad \frac{\partial \Pi}{\partial \eta} = \sum_{i=1}^N k_{i2} \delta_{i2}, \quad \frac{\partial \Pi}{\partial \zeta} = \sum_{i=1}^N k_{i3} \delta_{i3} + mg. \quad (12)$$

We note that finding the partial derivatives of the potential energy
with respect to coordinates ψ , θ , and φ is difficult, since it requires
that the same derivatives of matrix A be found. Therefore, taking into
account that the derivatives of Π for these coordinates are moments of the
elastic forces of the shock absorbers with respect to the axes of the
corresponding rotations of the body, we write the following equalities:

$$\begin{aligned} \frac{\partial \Pi}{\partial \psi} &= M'_1 \sin \varphi \sin \theta + M'_2 \cos \varphi \sin \theta + M'_3 \cos \theta; \\ \frac{\partial \Pi}{\partial \theta} &= M'_1 \cos \varphi - M'_2 \sin \varphi; \quad \frac{\partial \Pi}{\partial \varphi} = M'_3. \end{aligned} \quad (13)$$

The partial derivatives of potential energy with respect to generalized
velocities are equal to zero.

The kinetic energy of the system can be represented in the form

$$T = \frac{m}{2} (\dot{\xi}^2 + \dot{\eta}^2 + \dot{\zeta}^2) + \frac{1}{2} (I_1 \omega_x^2 + I_2 \omega_y^2 + I_3 \omega_z^2),$$

and with regard to the relations

$$\begin{aligned} \omega_x &= \dot{\psi} \sin \theta \sin \varphi + \dot{\theta} \cos \varphi, \quad \omega_y = \dot{\psi} \sin \theta \cos \varphi - \dot{\theta} \sin \varphi, \\ \omega_z &= \dot{\psi} \cos \theta + \dot{\varphi}, \end{aligned}$$

one can write

$$T = \frac{m}{2} (\dot{\xi}^2 + \dot{\eta}^2 + \dot{\zeta}^2) + \frac{1}{2} [I_1 (\dot{\psi} \sin \theta \sin \varphi + \dot{\theta} \cos \varphi)^2 + I_2 (\dot{\psi} \sin \theta \cos \varphi - \dot{\theta} \sin \varphi)^2 + I_3 (\dot{\psi} \cos \theta + \dot{\varphi})^2]. \quad (14)$$

Further postulation of expressions of the kinetic and potential energy into formula (11) results in implicit difference equations of numerical integration. This can be avoided in the case of equality of moments of inertia I_1 and I_2 , which is found rather frequently in real designs of vibration protection systems. Then, differentiating (14), we find the following expressions:

$$\begin{aligned} \frac{\partial T}{\partial \xi} = 0, \quad \frac{\partial T}{\partial \eta} = 0, \quad \frac{\partial T}{\partial \zeta} = 0, \quad \frac{\partial T}{\partial \dot{\xi}} = m\dot{\xi}, \quad \frac{\partial T}{\partial \dot{\eta}} = m\dot{\eta}, \quad \frac{\partial T}{\partial \dot{\zeta}} = m\dot{\zeta}; \\ \frac{\partial T}{\partial \psi} = 0, \quad \frac{\partial T}{\partial \dot{\psi}} = I_1 \dot{\psi}^2 \sin^2 \theta + I_3 (\dot{\varphi} + \dot{\psi} \cos \theta) \dot{\psi} \sin \theta, \quad \frac{\partial T}{\partial \dot{\varphi}} = 0; \\ \frac{\partial T}{\partial \dot{\psi}} = I_1 \dot{\psi} \sin^2 \theta + I_3 (\dot{\varphi} + \dot{\psi} \cos \theta) \cos \theta, \quad \frac{\partial T}{\partial \dot{\theta}} = I_1 \dot{\theta}; \\ \frac{\partial T}{\partial \dot{\varphi}} = I_3 (\dot{\varphi} + \dot{\psi} \cos \theta). \end{aligned} \quad (15)$$

After substitution of relations (12), (13) and (15) into (11) and also after certain transformations, we find the desired discrete model of motion of a solid in a flexible suspension:

$$\begin{aligned} \dot{\xi}_{t+1} &= e^{-nh} \left(\dot{\xi}_t - \frac{h}{m} \frac{\partial \Pi}{\partial \xi_t} \right), \quad \xi_{t+1} = \xi_t + h \dot{\xi}_{t+1}; \\ \dot{\eta}_{t+1} &= e^{-nh} \left(\dot{\eta}_t - \frac{h}{m} \frac{\partial \Pi}{\partial \eta_t} \right), \quad \eta_{t+1} = \eta_t + h \dot{\eta}_{t+1}; \\ \dot{\zeta}_{t+1} &= e^{-nh} \left(\dot{\zeta}_t - \frac{h}{m} \frac{\partial \Pi}{\partial \zeta_t} \right), \quad \zeta_{t+1} = \zeta_t + h \dot{\zeta}_{t+1}; \\ \dot{\psi}_{t+1} &= \frac{e^{-nh}}{I_1 \sin^2 \theta_{t+1}} [I_1 \dot{\psi}_t \sin^2 \theta_t + I_3 (\dot{\varphi}_t + \dot{\psi}_t \cos \theta_t) (\cos \theta_t - \cos \theta_{t+1}) + \\ &\quad + h \left(\frac{\partial \Pi}{\partial \varphi_t} \cos \theta_{t+1} - \frac{\partial \Pi}{\partial \psi_t} \right)], \\ \psi_{t+1} &= \psi_t + h \dot{\psi}_{t+1}; \\ \dot{\theta}_{t+1} &= e^{-nh} \left\{ \dot{\theta}_t + \frac{h}{I_1} \left[(I_1 - I_3) \dot{\psi}_t^2 \cos \theta_t \sin \theta_t - \right. \right. \\ &\quad \left. \left. - I_3 \dot{\psi}_t \dot{\varphi}_t \sin \theta_t - \frac{\partial \Pi}{\partial \theta_t} \right] \right\}, \\ \theta_{t+1} &= \theta_t + h \dot{\theta}_{t+1}; \end{aligned} \quad (16)$$

$$\dot{\varphi}_{i+1} = -\dot{\psi}_i \cos \theta_{i+1} + e^{-nh} \left(\dot{\varphi}_i + \dot{\psi}_i \cos \theta_i - \frac{h}{I_3} \frac{\partial II}{\partial \dot{\varphi}_i} \right),$$

$$\varphi_{i+1} = \varphi_i + h\dot{\varphi}_{i+1}.$$

We note that the expression $I_1 \sin^2 \theta_{i+1}$, which brings greater errors to the calculations at small angles θ , while it makes them possible at $\theta = 0$, is found in the denominator in the difference equation for $\dot{\varphi}_{i+1}$. This can be avoided, having assumed that the movable coordinate system Cxyz is rotated at initial moment of time with respect to the fixed coordinate system by angle $\theta_* = 90^\circ$ [6].

As studies showed, the use of difference equations (16), based on the principles of discrete variational calculation, is more effective in speed for simulation of the motion of a solid on a flexible suspension, described by equations (1), than the use of numerical integration of equations (1) by the Runge-Kutta method for the same purpose.

BIBLIOGRAPHY

1. Kolovskiy, M. Z., "Nelineynaya teoriya vibrozashchitnykh sistem" [Nonlinear Theory of Vibration-Protection Systems], Moscow, 1966.
2. Logan, J. D., "First Integrals in the Discrete Variational Calculus," AEQUAT. MATH., No 19, 1973.
3. Apostolyuk, A. S. V. B. Larin, and V. N. Sheludko, "On the Problem of Constructing Discrete Models of Mechanical Systems," MATEMATICHESKAYA FIZIKA I NELINEYNAYA MEKHANIKA, No 2 (36), 1984.
4. Zaplatnyy, V. I. and N. Ye. Tkachenko, "Construction of the Lagrange Function for Dissipative Systems Based on Solution of the Inverse Problem of Variational Calculus," DOKLADY AKADEMII NAUK UKRAINSKOY SSR. SERIYA A, No 4, 1984.
5. Appel, P., "Teoreticheskaya mekhanika. T. 2. Dinamika sistemy. Analiticheskaya mekhanika" [Theoretical Mechanics. Vol 2. Dynamics of the System. Analytical Mechanics], Moscow, 1960.
6. Sheludko, V. N., "On Digital Simulation of the Motion of a Solid," "Modelirovaniye i upravleniye dvizheniem sistemy tverdykh tel" [Simulation and Control of the Motion of a System of Solids], Kiev, 1984 (Preprint 84.6, AKADEMII NAUK UKRAINSKOY SSR. INSTITUT MATEMATIKI).

UDC 007.62

ALGORITHM FOR REAL-TIME CALCULATION OF REDUCED MOMENTS OF INERTIA OF
MULTILINK MANIPULATION SYSTEMS

907F0290R Kiev MEKHANIKA GIROSKOPICHESKIKH SISTEM in Russian, Issue 8,
1989 (manuscript received 14 Mar 88) pp 80-83

[Article by S. G. Bublik, senior engineer, Kiev Institute of Automation,
and V. S. Yevgenyev, candidate of technical sciences, Kiev Polytechnical
Institute]

[Text] The reduced moments of inertia of the links must be calculated on a computer to control the motion of complex manipulation anthropomorphic-type systems with large number of degrees of freedom [1]. In view of the fact that the memory capacity and speed of modern computers do not permit this operation in real time, the problem of such equivalent representation of the links of a manipulator as solids arises, which would simplify considerably the solution of the postulated problem. The purpose of the article is to outline a method of calculating the reduced moments of inertia of the links on mini- and microcomputers using construction of a system of material points, equimoment to arbitrary solids.

An equal moment system of the fewest number of points, which is equal to four, can be constructed to solve the considered problem [2]. The equal moment nature is guaranteed by the coincidence of the centers of inertia and by the equality of mass and tensors (ellipsoids) of inertia. If the principal central axes of inertia x , y , z are selected as the reduction axes, it is sufficient to require coincidence of only the axial moments of inertia. These conditions are expressed analytically by nine equations

$$\begin{aligned} \sum_1^4 m_i x_i^2 = A, \quad \sum_1^4 m_i y_i^2 = B, \quad \sum_1^4 m_i z_i^2 = C; \\ \sum_1^4 m_i x_i y_i = 0, \quad \sum_1^4 m_i y_i z_i = 0, \quad \sum_1^4 m_i x_i z_i = 0, \\ \sum_1^4 m_i x_i = 0, \quad \sum_1^4 m_i y_i = 0, \quad \sum_1^4 m_i z_i = 0, \end{aligned} \quad (1)$$

where A, B, and C are the moments of inertia of the link with respect to coordinate planes yz, xz and xy, respectively.

The desired system of four material points should belong to a second-order surface, which is an ellipsoid of inertia. Let us use the equimoment ellipsoid of inertia of the Legendre type, described by the following canonical expression, as this ellipsoid [2]

$$\frac{x^2}{A} + \frac{y^2}{B} + \frac{z^2}{C} = \frac{1}{M},$$

where M is the mass of the manipulator link.

Since it is difficult to determine directly the coordinates $(x_1, y_1, z_1), \dots, (x_4, y_4, z_4)$ of the four desired points, let us transform the coordinates according to the equalities

$$x_i = \frac{A}{M} \mu_i, \quad y_i = \frac{B}{M} p_i, \quad z_i = \frac{C}{M} q_i \quad (i = 1, 2, 3, 4). \quad (2)$$

If one assumes that the masses of the four material points are identical and equal to $M/4$, one can write equations (1) with regard to (2) with respect to the new coordinates μ_i, p_i, q_i in the form

$$\begin{aligned} \sum_1^4 \mu_i^2 &= 4, & \sum_1^4 p_i^2 &= 4, & \sum_1^4 q_i^2 &= 4; \\ \sum_1^4 \mu_i p_i &= 0, & \sum_1^4 p_i q_i &= 0, & \sum_1^4 \mu_i q_i &= 0; \\ \sum_1^4 \mu_i &= 0, & \sum_1^4 p_i &= 0, & \sum_1^4 q_i &= 0. \end{aligned} \quad (3)$$

It follows from equations (3) that the ellipsoid of inertia of the four material points is a sphere of unit radius. To simplify the calculating procedure, let us select the desired points at the vertices of a right tetrahedron, lying on the sphere.

It is insufficient to determine 12 coordinates μ_i, p_i, q_i ($i = 1, 2, 3, 4$) of a system of nine equations (3). Taking into account that the axes of symmetry for a homogeneous solid are the principal central axes of inertia and by locating one of the points on axis z, we find additional relations:

$$\mu_1 = p_1 = 0; \quad q_1 = \sqrt{3}. \quad (4)$$

We note that if the solid is homogeneous, conditions (4) vary according to the geometry of the mass.

Solving algebraic system of equations (3) with regard to conditions (4), we find

$$\begin{pmatrix} \mu_1 \\ p_1 \\ q_1 \end{pmatrix} = \begin{pmatrix} 0 \\ 0 \\ \sqrt{3} \end{pmatrix}; \quad \begin{pmatrix} \mu_2 \\ p_2 \\ q_2 \end{pmatrix} = \begin{pmatrix} 0 \\ 2\sqrt{\frac{2}{3}} \\ -\frac{1}{\sqrt{3}} \end{pmatrix}; \\ \begin{pmatrix} \mu_3 \\ p_3 \\ q_3 \end{pmatrix} = \begin{pmatrix} \sqrt{2} \\ -\sqrt{\frac{2}{3}} \\ -\frac{1}{\sqrt{3}} \end{pmatrix}; \quad \begin{pmatrix} \mu_4 \\ p_4 \\ q_4 \end{pmatrix} = \begin{pmatrix} -\sqrt{2} \\ -\sqrt{\frac{2}{3}} \\ -\frac{1}{\sqrt{3}} \end{pmatrix}.$$

Turning to the initial coordinates x_i, y_i, z_i from formulas (2), we find

$$\begin{aligned} \vec{r}_1 &= \left\{ 0; 0; \sqrt{\frac{3C}{M}} \right\}, \quad \vec{r}_2 = \left\{ 0; 2\sqrt{\frac{2B}{3M}}; -\sqrt{\frac{C}{3M}} \right\}, \\ \vec{r}_3 &= \left\{ \sqrt{\frac{2A}{M}}; -\sqrt{\frac{2B}{3M}}; -\sqrt{\frac{C}{3M}} \right\}, \\ \vec{r}_4 &= \left\{ -\sqrt{\frac{2A}{M}}; -\sqrt{\frac{2B}{3M}}; -\sqrt{\frac{C}{3M}} \right\}. \end{aligned} \quad (5)$$

Formulas (5) permit one to determine the coordinates of the desired system of four point masses, equimoment to the manipulator link in the principal central axes of inertia x, y, z , bound to it. One can turn to the physical axes of the suspension ξ, η, ζ by parallel transfer of coordinate system xyz to values ξ_0, η_0, ζ_0 and by rotation by Euler angles α, β and γ . The reduced moment of inertia of the link with respect to the axes of its suspension can then be calculated by the formulas

$$\begin{aligned} I_\xi &= I_x a_{11}^2 + I_y a_{21}^2 + I_z a_{31}^2 + M\xi_0^2, \\ I_\eta &= I_x a_{12}^2 + I_y a_{22}^2 + I_z a_{32}^2 + M\eta_0^2, \\ I_\zeta &= I_x a_{13}^2 + I_y a_{23}^2 + I_z a_{33}^2 + M\zeta_0^2. \end{aligned} \quad (6)$$

Here a_{ij} are the direction cosines that determine the angular orientation of axes x , y , z and that are dependent on the method of being given the Euler angles [3] and I_x , I_y , and I_z are the moments of inertia of the link with respect to the corresponding axes.

The relationship between these moments of inertia and A , B , and C used earlier is determined by the identities

$$\begin{aligned} A &= 0,5(I_y + I_z - I_x); & B &= 0,5(I_z + I_x - I_y); \\ C &= 0,5(I_x + I_y - I_z). \end{aligned} \quad (7)$$

The derived formulas permit one to calculate the reduced moments of inertia of multilink manipulation systems according to the following algorithm.

1. Find the mass M of links, the position of their centers of inertia, and the distances ξ_0 , η_0 , and ζ_0 from these centers to the suspension axes of the links.
2. Assign the Euler angles α , β , and γ and calculate the direction cosines a_{ij} for each link of the manipulator.
3. Determine the axial moments of inertia of links I_x , I_y , and I_z and find A , B , C by formulas (7).
4. Calculate the coordinates of four points by mass $M/4$ for each link by formulas (5).
5. Find the moments of inertia of equipoint systems of material points, which replace the links of the manipulator, with respect to the principal central axes of inertia.
6. Calculate the reduced moments of inertia of the links with respect to their suspension axes by formulas (6).

Computer programs for calculating the reduced moments of inertia of the simplest type of links--parallelepiped, cylinder, truncated cone and triangular pyramid--were worked out according to the proposed algorithms. The computation time on the SM 1810.41 microcomputer is $2 \cdot 10^{-3}$ s, which indicates the effectiveness of the algorithm.

BIBLIOGRAPHY

1. Yevgenyev, V. S. and S. G. Bublik, "Compensation of Dynamic Effects on the Drive of a Manipulation Robot During Control of Its Motion," MEKHANIKA GIROSKOPICHESKIKH SISTEM, No 6, 1987.

2. Raus, E. J., "Dinamika sistemy tverdykh tel" [The Dynamics of a Solid System], Vol 1, Moscow, 1983.
3. Boychuk, O. F. and V. S. Yevgenyev, "Metodicheskiye ukazaniya k izucheniyu kursa teoreticheskoy mekhaniki 'Spetsialnyye parametry v kinematike tverdogo tela' dlya studentov mekhanicheskikh spetsialnostey" [Methodical Instructions to Study of the Course of Theoretical Mechanics "Special Parameters in the Kinematics of a Solid" for Students of Mechanical Specialties], Kiev, 1982.

UDC 628.517

NONLINEAR EFFECTS IN VIBRATION-PROTECTIVE SYSTEMS WITH STIFFNESS
CORRECTORS

907F0290S Kiev MEKHANIKA GIROSKOPICHESKIKH SISTEM in Russian, Issue 8,
1989 (manuscript received 9 Oct 87) pp 83-87

[Article by B. I. Genkin, candidate of technical sciences, N. I. Nagulin, candidate of technical sciences, and A. G. Arkhipov, senior scientific associate, Severodonetsk Branch of Kharkov Institute of Radio Electronics]

[Text] The timely problems of modern instrument building include the development of devices, capable of operating stably at low-frequency and infralow-frequency, for example, seismic effects. One of the promising ways of solving this problem is to use vibration insulators with stiffness correctors [1]. These correctors permit one to optimize the dynamic elastic characteristic of vibration insulators, without influencing their static capacity. Deviations of the parameters of the stiffness correctors from optimal values are inevitable in view of the different types of random factors. Therefore, real dynamic elastic characteristics of vibration insulators with stiffness correctors are always nonlinear. The given paper is devoted to analysis of some types of nonlinear vibration-protective systems with stiffness correctors.

Let us consider a system with one degree of freedom, consisting of a vibration-protection object of mass m , attached to a base, vibrating by law $h(t) = h_0 \sin \omega t$ by parallel-connected main spring of stiffness c , a viscous damper with viscosity coefficient μ and stiffness corrector, the characteristics of which are: c_k is the stiffness of the corrector spring, d is the maximum deformation of the corrector spring, and L is a geometric parameter. Let us take the displacement x of the vibration-protection object with respect to the position of equilibrium as the generalized coordinate.

Let us introduce the dimensionless coordinate $\xi = x/L$ and dimensionless parameters $\alpha = s_k/s$ and $\beta = d/L$. The dynamic flexible characteristic $F(x, c, c_k, d, L)$ of the vibration insulator, consisting of the main

spring and stiffness corrector, is represented in the form $F(x, c, c_k, d, L) = cLf(\xi, \alpha, \beta)$ where $f(\xi, \alpha, \beta)$ is the dimensionless dynamic elastic characteristic of the vibration insulator. Let us compile a differential equation with respect to vibrations of the vibration-protection object and let us reduce it to the form

$$\ddot{\xi} + 2n\xi + k^2f(\xi, \alpha, \beta) = j\omega^2 \sin \omega t, \quad (1)$$

where $n = \mu/2m$; $k = \sqrt{c/m}$; $\gamma = h_0/L$.

To find the approximate steady state solution of equation (1), let us use one of the linearization methods [2, 3]. Let us find this solution in the form

$$\xi = A \sin(\omega t - \varphi). \quad (2)$$

Let us replace nonlinear function $f(\xi, \alpha, \beta)$ by the approximate function

$$f(\xi, \alpha, \beta) \approx q^2(A, \alpha, \beta)\xi, \quad (3)$$

where $q^2(A, \alpha, \beta)$ are linearization coefficients. Having substituted (2) and (3) into (1), after transformations, we find

$$A = \gamma p^2 / \sqrt{[q^2(A, \alpha, \beta) - p^2]^2 + 4\delta^2 p^2}, \quad (4)$$

$$\varphi = \text{arctg} [2\delta p / [q^2(A, \alpha, \beta) - p^2]], \quad (5)$$

where $p = \omega/k$ and $\delta = n/k$.

Relation (4) is an equation with respect to amplitude A and describes the amplitude-frequency characteristic (AChKh) of the system. Relation (5) describes the phase-frequency characteristic (FChKh) of the system.

Let us consider two types of stiffness correctors: crank (Figure 1, a) and cam (Figure 1, b) [1]. The dimensionless elastic characteristic of the vibration insulator containing these correctors is:

$$f(\xi, \alpha, \beta) = [1 - \alpha + \alpha(1 - \beta)/\sqrt{1 - \xi^2}]\xi. \quad (6)$$

Having used Ya. Z. Tsypkin's formula [2], we find the linearization coefficient:

$$q^2(A, \alpha, \beta) = 1 - \alpha + \frac{2}{3} \alpha (1 - \beta) [(4 - A^2)^{-1/2} + (1 - A^2)^{-1/2}]. \quad (7)$$

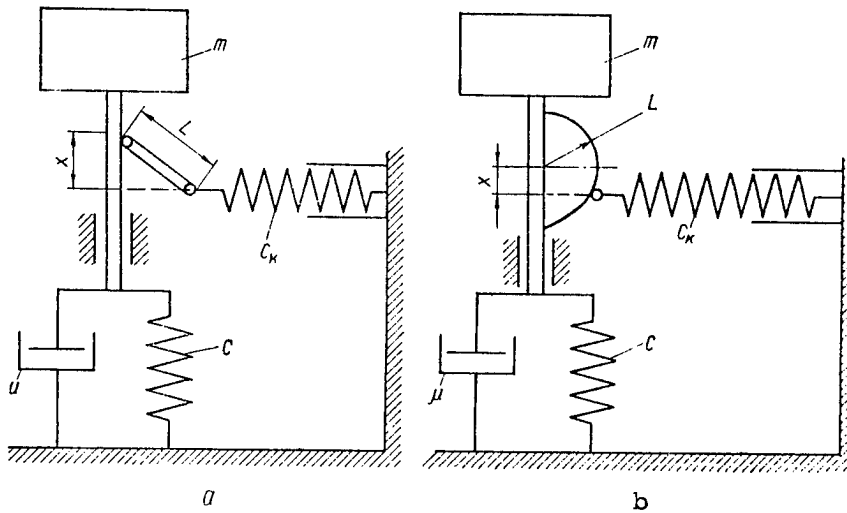

Figure 1

A computer program that realizes with step by frequency parameter p the search for the roots of equations (4), where $q^2(A, \alpha, \beta)$ has the form of (7), with subsequent calculation of the values of φ and also of the amplitudes and phases of the absolute vibrations of the vibration-protection object, was worked out to study the characteristic features of the considered nonlinear systems. Analysis of the results of numerical experiment, conducted by using this program, showed the following. Equation (4) can have only one real root at small values of parameter γ , which characterizes the intensity of the exciting effect, and the amplitude-frequency characteristic of the vibration-protection object hardly differs from that found when using linear theory. A range of values of p , at which equation (4) has up to three real roots, appears with an increase of γ , the amplitude-frequency characteristic assumes a form typical for nonlinear systems: the resonant peak (curve 1, found at $\delta = 0.1$ in Figure 2) is deformed, and additional branches of the amplitude-frequency characteristic (curves 2 and 3 in Figure 2) appear, to which the vibrations with large amplitudes correspond. Study of the stability showed that curve 2 corresponds to stable modes, while curve 3 corresponds to unstable modes of induced vibrations.

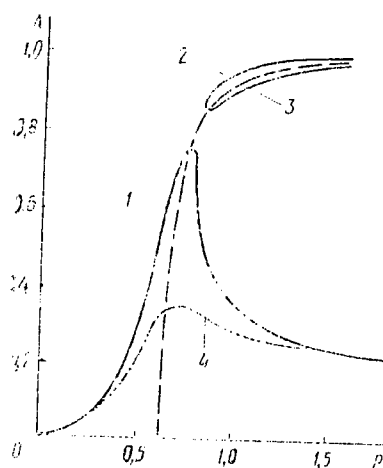

Figure 2

With an increase of parameter δ which characterizes the friction in the system, additional branches of the amplitude-frequency characteristic have a tendency toward fusion and displacement to a higher frequency region. Figure 2 was constructed for cases when the amplitude of the induced effect is independent of frequency ($\gamma = \text{const}$). Under real conditions, the amplitudes of higher harmonics of the kinematic induced effect is ordinarily much less than the amplitudes of several of the first harmonics. Thus, displacement of additional branches of the amplitude-frequency characteristic to a higher frequency range means the elimination of the danger of the corresponding large-amplitude vibrations occurring [3]. Curve 4 in Figure 2 was found at $\delta = 0.2$. There are no additional branches of the amplitude-frequency characteristic. At the same time, an increase of friction results in some deterioration of the quality of vibration protection in the working frequency band. Accordingly, there is the problem of optimization of parameter δ .

A system with crank stiffness corrector on a low-frequency vibration bench, which permits one to increase the vibration amplitude of the vibrator to 15 mm, was tested for an experimental check of the results. The system to be tested contained four air dampers with replaceable pistons. Energy dissipation in the system was varied by mounting the pistons with openings of different area. Stable vibrations with large amplitude, corresponding to the positive branches of the amplitude-frequency characteristics, were observed at low friction. There were no nonlinear effects at high friction and also at small vibration amplitudes of the vibrator of the vibration table.

Studies showed that the possibilities of large-amplitude vibrations in the working frequency band, which occur due to nonlinearity of the elastic characteristics of these systems, must be taken into account in design of vibration-protection systems with stiffness correctors. To

eliminate the undesirable nonlinear effects, one should try to see that parameter γ have a rather small value, while parameter δ have a rather large value. A decrease of γ at given h_0 is possible only due to an increase of L , i.e., due to an increase of the overall dimensions of the stiffness corrector. An increase of δ results in deterioration of the vibration protection quality in the working frequency band. Thus, selection of the parameters of vibration-protection systems with stiffness correctors is an optimization problem.

BIBLIOGRAPHY

1. Alabuzhev, P. M., A. A. Gritchik, L. N. Kim et al., "Vibrozhachitnyye sistemy s kvazinulevoy zhestkostyu" [Vibration-Protection Systems With Quasi-Zero Stiffness], Leningrad, 1986.
2. Babakov, I. M., "Teoriya kolebaniy" [Vibration Theory], Moscow, 1958.
3. Kolovskiy, M. Z., "Nelineynaya teoriya vibrozashchitnykh sistem" [Nonlinear Theory of Vibration-Protection Systems], Moscow, 1966.-

UDC 517.946.9

MATHEMATICAL PROBLEMS OF DYNAMICS OF VISCOUS LIQUID IN GYROSCOPY

907F0290T Kiev MEKHANIKA GIROSKOPICHESKIKH SISTEM in Russian, Issue 8, 1989 (manuscript received 26 Nov 87) pp 87-91

[Article by G. A. Legeyda, candidate of physicomathematical sciences, Kiev Polytechnical Institute]

[Text] Calculation and design of modern floated gyroscopic devices are related to postulation and solution of convective heat transfer problems in a working liquid. Typical forms of the suspensions of the sensitive elements are a cylinder in a cylinder, and sphere in a sphere; therefore, the desire to maintain the greatest number of symmetries in the design results in study of axi- and central-symmetrical problems. The basis for using numerical-analytical methods in solving these problems is information about the existence of the solution in general and about its behavior at different moments of time.

Theorems on single-valued solvability as a whole and on the asymptotic stability of the solution of a system of quasi-linear evolutionary equations that describe the thermoconvective dynamics of a viscous incompressible liquid, which fills an axisymmetrical cavity in a solid coaxial to it, are presented in this paper. The problem to be studied is formulated in terms of the current ψ -temperature θ function.

1. If the liquid fills a cavity, which is the figure of revolution of a rectangle $\pi = \{(r, z) | 0 < R < r < R_1, h_1 < z < h_2\}$ about axis Oz in a solid having the shape of a figure of revolution about axis Oz of triangle $\Pi = \{(r, z) | 0 \leq r \leq R_2, H_1 < z < H_2 (R_1 < R_2, H_1 < h_1 < h_2 < H_2)\}$, then the convective heat and mass transfer in it is described, as is known [1-3], by a system of equations

$$D\psi_t - r\partial(\psi, r^{-2}D\psi)/\partial(r, z) - \nu D^2\psi = -\gamma r\theta_r, (r, z, t) \in \pi^T; \quad (1)$$

$$\sigma[\Theta_t - r^{-1}\partial(\psi, \Theta)/\partial(r, z)] - \lambda\nabla^2\Theta = 0, \quad (r, z, t) \in \tilde{\Pi}^T \quad (2)$$

with initial conditions of type

$$\psi = \psi_0(r, z), \quad (r, z) \in \pi; \quad \Theta = \Theta_0(r, z), \quad (r, z) \in \Pi; \quad t = 0 \quad (3)$$

and with boundary conditions

$$\psi = D\psi = 0, \quad (r, z) \in \partial\pi; \quad \Theta = 0, \quad (r, z) \in \partial\Pi; \quad t \geq 0; \quad (4)$$

$$[\Theta] = [\lambda\partial\Theta/\partial n] = 0, \quad (r, z) \in \partial\pi; \quad t \geq 0, \quad (5)$$

where $\nabla^2 \equiv r^{-1}\partial/\partial r(r\partial/\partial r) + \partial^2/\partial z^2$; $D \equiv r\partial/\partial r(r^{-1}\partial/\partial r) + \partial^2/\partial z^2$; $D^2 \equiv DD$; $\partial(\psi, \dot{X})/\partial(r, z) = \partial\psi/\partial r \partial X/\partial z - \partial\psi/\partial z \partial X/\partial r$; $\pi^T = \pi \times [0, T]$; $\tilde{\Pi}^T = [\pi \cup (\Pi \setminus \bar{\pi})] \times [0, T]$; and \bar{n} is the external normal to the boundary $\partial\pi = \bar{\pi}/\pi$; $[\tau]$ is a jump on the $\partial\pi$ function $t(r, z) \in \tilde{\Pi}$, equal to $(\tau'' - \tau')|_{\partial\pi}$ (the constrictions τ by π and Π , respectively, are denoted by τ' and τ''), $\nu, \gamma, \lambda', \lambda'', \sigma''$ and σ' are positive constants that characterize the physical properties of the liquid and solid ($\lambda' \neq \lambda'', \sigma' \neq \sigma''$), and t is time.

It should be noted that rectangles were selected as π and Π in problem (1)-(5) only for clarity. The theorems presented below are also valid when π and Π are arbitrary constrained areas with rather smooth boundaries and π lags behind axis Oz by $R > 0$.

Conditions $\psi = D\psi = 0$ are not equivalent to classical conditions of adhesion of the liquid to a solid wall $\partial\pi$ (these conditions are discussed in detail in [3]). The conditions of adhesion will be fulfilled if problem (1)-(5) is altered somewhat, having replaced equation (1) and condition (4) by the equalities

$$D(r^{-2}D\psi_t) - D[r^{-1}\partial(\psi, r^{-2}D\psi)/\partial(r, z)] - D(r^{-2}D^2\psi) = -D(r^{-1}\Theta_t), \\ \psi|_{\partial\pi} = \partial\psi/\partial n|_{\partial\pi} = D\psi|_{\partial\pi} = 0.$$

The single-valued solvability as a whole (with respect to t) of this problem is proved by the same scheme as problems (1)-(5).

2. Let $L_p(\pi)$ be a Banach space, consisting of all functions $\varphi(r, z)$, measured on π , and added with respect to π with superscript $p \geq 1$; $L_p(\pi)$ is equipped with evaluation

$$\|\varphi\|_{p,\pi} = \left(\int_{\pi} |\varphi|^p r dr dz \right)^{1/p} (\|\cdot\|_{2,\pi} \equiv \|\cdot\|_{\pi}).$$

Following [2, 4], let us introduce Hilbert spaces $L_2(\pi)$, $L_2^{\sigma}(\Pi)$, $W_{2,0}^{(1)}(\pi)$, $W_{2,0}^{(1)}(\Pi)$, $W_{2,0}^{(2)}(\pi)$, $W_{2,0}^{(3)}(\pi)$ with scalar products

$$\begin{aligned} (\varphi, \psi)_{\pi} &= \int_{\pi} \varphi \psi r dr dz; & (\Theta, \tau)_{\Pi} &= \int_{\Pi} \sigma \Theta \tau r dr dz; \\ (\varphi, \psi)_{(1),\pi} &= \int_{\pi} (\nabla \varphi \nabla \psi) r dr dz; & (\Theta, \tau)_{(1),\Pi} &= \int_{\Pi} \sigma^2 \nabla \Theta \nabla \tau r dr dz; \\ (\varphi, \psi)_{(2),\pi} &= \int_{\pi} r^{-2} D \varphi r^{-2} D \psi r dr dz; \\ (\varphi, \psi)_{(3),\pi} &= \int_{\pi} \nabla (r^{-2} D \varphi) \nabla (r^{-2} D \psi) r dr dz \end{aligned}$$

and which correspond to valuations $\|\cdot\|_{\pi}$, $\|\cdot\|_{(1),\pi}$, $\|\cdot\|_{(i),\pi}$ ($i = 1, 2, 3$).

The space $W_{2,0}^{(i)}(\pi)$ ($i = 1, 2$) consists of all elements of the Sobolev space $W_{i,2}(\pi)$, which have zero sign on $\partial\pi$, while $W_{2,0}^{(3)}(\pi)$ consists of all functions φ of space $W_{3,2}(\pi)$, for which the sign $D\varphi$ is equal to zero on $\partial\pi$ together with sign φ (since $R > 0$, the valuations $\|\cdot\|_{(i),\pi}$ ($i = 1, 2, 3$) are equivalent to those of the corresponding Sobolev spaces). Space $W_{2,0}^{(1)}(\Pi)$ consists of all elements of space $W_{1,2}(\Pi)$ with zero sign on $\partial\Pi$.

Let us denote by $V_{2,0}^{1,0}(\pi^T)$, $V_{2,0}^{1,1}(\pi^T)$, $V_{2,0}^{2,1}(\pi^T)$, $V_{2,0}^{3,0}(\pi^T)$ ($V_{2,0}^{1,0}(\Pi^T)$) the Banach spaces of functions $\psi(r, z, t)$ ($\theta(r, z, t)$) from $C^0(0, T; L_2(\pi)) \cap L_2(0, T; W_{2,0}^{(1)}(\pi))$; $V_{2,0}^{1,0}(\pi^T) \cap W_2^1(0, T; L_2(\pi))$; $C^0(0, T; W_{2,0}^{(2)}(\pi)) \cap W_2^1(0, T; W_{2,0}^{(1)}(\pi))$; $C^0(0, T; W_{2,0}^{(3)}(\pi)) \cap L_2(0, T; W_{2,0}^{(3)}(\pi)) \times (C^0(0, T; L_2^{\sigma}(\Pi)) \cap L_2(0, T; W_{2,0}^{(1)}(\Pi)))$ respectively, supplied with valuations

$$\begin{aligned} |\psi|_{V_{2,0}^{1,0}(\pi^T)} &= \max_{0 \leq t < T} \|\psi\|_{\pi} + \|\nabla \psi\|_{\pi^T}, \\ |\psi|_{V_{2,0}^{1,1}(\pi^T)} &= |\psi|_{V_{2,0}^{1,0}(\pi^T)} + \|\psi_t\|_{\pi^T}, \\ |\psi|_{V_{2,0}^{2,1}(\pi^T)} &= |\psi|_{V_{2,0}^{1,1}(\pi^T)} + \max \|\psi\|_{(2),\pi} + \|\nabla \psi_t\|_{\pi^T}, \end{aligned}$$

$$|\psi|_{V_{2,0}^{3,0}(\pi^T)} = \left(\max_{0 \leq t \leq T} \|\psi\|_{(2),\pi}^2 + \int_0^T \|\psi\|_{(3),\pi}^2 dt \right)^{1/2}$$

$$(|\Theta|_{V_{2,0}^{1,0}(\Pi^T)}) = \max_{0 \leq t \leq T} \|\Theta\|_{\Pi} + \|\nabla\Theta\|_{\Pi^T},$$

where $\|\psi\|_{\pi^T}^2 = (\psi, \psi)_{\pi^T}$, $(\varphi, \psi)_{\pi^T} = \int_0^T (\varphi, \psi)_{\pi} dt$; $H_1(0, T; H_2(\pi))$ is an ordinary space [4] of distributions from $[0, T]$ in $H_2(\pi)$ with properties of space H_1 (with respect to t).

Finally, let us denote by $V^{3,1/2}_{2,0}(\pi^T)$ the space of functions $\psi(r, z, t)$ from $V^{3,0}_{2,0}(\pi^T)$, for which

$$h^{-1} \int_0^{T-h} \|\psi(r, z, t+h) - \psi(r, z, t)\|_{(2),\pi}^2 dt \xrightarrow{h \rightarrow 0} > 0.$$

The spaces $V_{2,0}^{1,0}(\Pi^T)$, $V_{2,0}^{1,1}(\Pi^T)$ and $V_{2,0}^{1,1/2}(\Pi^T) \subset V_{2,0}^{1,0}(\Pi^T)$ are determined in similar fashion.

3. Let us call the pair of functions $\{\psi, \theta\}$, belonging to space $V_{2,0}^{3,0}(\pi^T) \times V_{2,0}^{1,0}(\Pi^T)$ and which satisfies the following integral identities the generalized solution of problem (1)-(5)

$$\int_{\pi} r^{-1} \varphi D\psi dr dz \Big|_{t=0}^{t=t_1} + \int_{\pi^t} [-r^{-1} \varphi_t D\psi - \varphi \partial(\psi, r^{-2} D\psi) / \partial(r, z) +$$

$$+ vr^{-1} (\nabla D\psi \nabla \varphi)] dr dz dt = \int_{\pi^t} \theta \varphi_r dr dz dt; \quad (6)$$

$$\int_{\Pi} \sigma \theta \tau r dr dz \Big|_{t=0}^{t=t_1} + \int_{\Pi^t} [-r \sigma \theta \tau_t - \sigma \partial(\psi, \theta) / \partial(r, z) \tau +$$

$$+ r \lambda (\nabla \theta \nabla \tau)] dr dz dt = 0 \quad (7)$$

$\forall t_1$ from $[0, T]$ and arbitrary pair $\{\varphi, \tau\}$ from $V_{2,0}^{1,1}(\pi^T) \times V_{2,0}^{1,1}(\Pi^T)$.

It is easy to show that the classical solution of problem (1)-(5) satisfies relations (6) and (7) and that the determination is correct,

in other words, all the integrals in (6) and (7) have meaning (since $R > 0$, i.e., the axis of symmetry does not belong to a liquid-filled cavity).

Theorem 1. If the initial data of problem (1)-(5) are such that

$\psi_0 \in W_{2,0}^{(2)}(\pi)$, $\theta_0 \in L_2(\Pi)$, it has a unique generalized solution $(\psi, \theta) \in V_{2,0}^{3,1/2}(\pi^T) \times V_{2,0}^{1,1/2}(\Pi^T)$ at arbitrary final solution T . Moreover, the following integral relations are valid for (ψ, θ)

$$\begin{aligned} 2^{-1} \int_{\pi} \vec{V}^2 r dr dz \Big|_{t=0}^{t=t_1} + \nu \int_{\pi^t} \omega^2 r dr dz dt &= \gamma \int_{\pi^t} \theta \sigma^2 r dr dz dt, \\ 2^{-1} \int_{\pi} |\omega/r|^2 r dr dz \Big|_{t=0}^{t=t_1} + \nu \int_{\pi^t} |\nabla(\omega/r)|^2 r dr dz dt &= \gamma \int_{\pi^t} \theta d/dr(\omega/r) r dr dz dt, \\ 2^{-1} \int_{\Pi} \sigma \theta^2 r dr dz \Big|_{t=0}^{t=t_1} + \int_{\Pi^t} \lambda (\nabla \theta)^2 r dr dz dt &= 0 \end{aligned}$$

and the valuations

$$|\psi|_{V_{2,0}^{3,0}(\pi^t)} \leq C_1 \|\psi_0\|_{(2),\pi} + C_2 t^{1/2} r_1^{-1} \|\theta_0\|_{\Pi}; \quad |\theta|_{V_{2,0}^{1,0}(\Pi^t)} \leq C_3 \|\theta_0\|_{\Pi},$$

in which constants C_j ($j = \overline{1, 3}$) are positive and are dependent only on the coefficients of equations (1) and (2), and $V = (v^r, v^z)$ is a velocity vector.

The answer to the question on the behavior of the solution of system (1)-(5) at $t \rightarrow \infty$ yields the following confirmation.

Theorem 2. The generalized solution $\{\psi, \theta\}$ of the quasi-linear non-stationary problem (1)-(5) is asymptotically stable at $W^{(2)}_{2,0}(\pi) \times L_2(\Pi)$, i.e.,

$$\begin{aligned} \|\theta\|_{\Pi} &\leq C_4 \|\theta_0\|_{\Pi} e^{-C_5 t}, \\ \|\psi\|_{(2),\pi}^2 &\leq C_6 \|\psi_0\|_{(2),\pi}^2 e^{-C_7 t} + \frac{C_7(C_8 - 2C_5)}{r_1^2} \|\theta_0\|_{\Pi}^2 (e^{-2C_5 t} - e^{-C_7 t}), \end{aligned}$$

where the positive constants C_j ($j = \overline{4, 8}$) are dependent only on the coefficients of equations (1) and (2).

4. The methods of [1-3] based on quantification with respect to t with subsequent linearization and splitting of equations (1) and (2) according to the following scheme are effective upon numerical solution of the problem of thermal convection of the liquid in gyroscopes:

$$D\psi_k - D\psi_{k-1} - \tau[r\partial(\psi_{k-1}, r^{-2}D\psi_k)/\partial(r, z) + \nu D^2\psi_k] = -\tau r \gamma \partial\theta_k/\partial r; \quad (8)$$

$$\sigma(\Theta_k - \Theta_{k-1}) - \tau[r^{-1}\partial(\psi_{k-1}, \Theta_k)/\partial(r, z) + \lambda \nabla^2\Theta_k] = 0, \quad (9)$$

where τ is a time step, $k = \overline{1, m}$ is the number of the time layer, and $t_k = k\tau$, $\Theta_k = \Theta(t_k)$, $\psi_k = \psi(t_k)$.

Let us apply the Galerkin method with a finite element Hermitian basis on triangulation Γ_h of domain Π to system (8) and (9). The approximate

solution of ψ^h and Θ^h in domains $\pi^h = \bigcup_{e \in \pi} e$ and $\Pi^h = \bigcup_{e \in \Pi} e$ will be found

in the form $\psi^h(r, z, t) = N(r, z)\bar{\psi}(t)$, $\Theta^h(r, z, t) = N(r, z)\bar{\Theta}(t)$, where $\bar{\psi}(t) = \{\bar{\psi}_1, \bar{\psi}_2, \dots, \bar{\psi}_{m_1}\}^T$, $\bar{\Theta}(t) = \{\bar{\Theta}_1, \bar{\Theta}_2, \dots, \bar{\Theta}_{m_2}\}^T$ are the desired values of the corresponding functions and of their derivatives at the nodal points of domains π^h and Π^h , $m_i = m_i(\Gamma_h)$ ($i = 1, 2$), e is a triangular element of domain Π , and $N(r, z) = \{N_1, \dots, N_m\}$ is a vector of basic functions [2, 3].

Using the known procedure [1-3] of the finite element method in combination with the Galerkin method and taking into account conditions (3)-(5), we find a system of linear algebraic equations of type $Ax = B$, where A is a square matrix with band structure, and B is a vector, and the desired values of vectors $\bar{\psi}(t)$ or $\bar{\Theta}(t)$ emerge as the unknown vector x . The given procedure can be generalized rather easily to solution of other initial boundary value problems for parabolic-type equations.

BIBLIOGRAPHY

- Galitsyn, A. S. and G. A. Legeyda, "On Numerical Study of the Dynamics of Thermal Convection in a Closed Volume of a Viscous Liquid by the Finite Element Method," "Matematicheskkiye voprosy mekhaniki sploshnykh sred i teplofiziki" [Mathematical Problems of the Mechanics of Solids and Thermal Physics], Kiev, 1982.

2. Galitsyn, A. S., G. A. Legeyda, and V. P. Moseykov, "Axial Symmetric Quasi-Linear Conjugate Problems of Non-Stationary Convection and the Projection-Grid Method of Solving Them," Kiev, 1984 (Preprint 84.22 of Institute of Mathematics, Ukrainian SSR Academy of Sciences).
3. Galitsyn, A. S. and G. A. Legeyda, "Problems of Numerical Solution of Initial Boundary Value Problems of Convection in Limited Volume of Viscous Liquid by Finite Element Method," Kiev, 1987 (Preprint 87.1 of Institute of Mathematics, Ukrainian SSR Academy of Sciences).
4. Ladyzhenskaya, O. A., "On Single-Valued Solubility in Entire Three-Dimensional Cauchy Problem for Navier-Stokes Equations in the Presence of Axial Symmetry," ZAPISKI NAUCHNOGO SEMINARA LENINGRADSKOGO OTDELENIYA MATEMATICHESKOGO INSTITUTA AKADEMII NAUK SSSR, No 7, 1968.

UDC 62.502

DESIGN OF OPTIMAL FOLLOW-UP SYSTEM WITH COMBINATION CONTROL

907F0290U Kiev MEKHANIKA GIROSKOPICHESKIKH SISTEM in Russian, Issue 8, 1989 (manuscript received 9 Sep 87) pp 92-96

[Article by V. V. Lyakin, candidate of technical sciences, and V. V. Tsisarzh, post-graduate student]

[Text] An effective solution of the problem of improving the accuracy in design of follow-up systems is to use combination control together with methods of invariance theory. The problem of designing an optimal follow-up system with combination control in the presence of random noise, based on the design system developed in [1], is solved in this article.

Let the block diagram of the follow-up system with combination control have the form shown in the figure. The system includes the controlled object with transfer function $W_0(s)$, a regulator $W_1(s)$, master signal meter $q(t)$ with transfer function $W(s)$ and filter $W_\Phi(s)$. The problem of optimal design includes determination of the transfer functions of the regulator $W_1(s)$ and of the filter $W_\Phi(s)$, which supply a minimum of the following functional in the class of stable closed systems

$$I = r \langle \varepsilon^2(t) \rangle + c \langle U^2(t) \rangle \quad (1)$$

at given $W_0(s)$ and $W(s)$, at known statistical characteristics--noise $R(t)$ and $n(t)$ and with arbitrary variation of the master signal $q(t)$.

Let us write the equations for a Laplace error transform for the combination follow-up system and control signal according to the block diagram

$$\begin{aligned} \varepsilon(s) &= [1 - F_1(s) - F_2(s)W_0(s)]q(s) + W_0(s)F_2(s)n(s) + \\ &\quad + [1 - F_1(s)]R(s); \\ U(s) &= [F_1(s)W_0^{-1}(s) + F_2(s)]q(s) + F_2(s)n(s) + F_1(s)W_0^{-1}(s)R(s), \end{aligned} \quad (2)$$

where

$$\begin{aligned} F_1(s) &= W_1(s)W_0(s)[1 + W_1(s)W_0(s)]^{-1}; \\ F_2(s) &= W(s)W_\Phi(s)[1 + W_1(s)W_0(s)]^{-1}. \end{aligned} \quad (3)$$

As is known [2], the transfer function of the closed system should be equal to unity to guarantee the absolute invariance of the system with respect to the master effect $q(t)$. However, it is impossible to realize an infinite bandwidth in real systems; therefore, let us require that the following equality is fulfilled in the system to be designed

$$F_1(s) + F_2(s)W_0(s) = E(s), \quad (4)$$

where $E(s)$ is some transfer function, close to unity in the proposed range of variation frequencies of the master effect.

If the following ratio is added to equality (4) according to [1]

$$\alpha(s)F_1(s) + \beta(s)F_2(s) = \Phi(s), \quad (5)$$

where $\alpha(s)$ and $\beta(s)$ are some polynomials of s , the system of equations (4) and (5) permits one to express transfer functions $F_1(s)$ and $F_2(s)$ and functional (1) to be minimized by a single function $\Phi(s)$:

$$\begin{aligned} F_1(s) &= \frac{[E(s)\beta(s) - W_0(s)\Phi(s)]}{[\beta(s) - \alpha(s)W_0(s)]}, \\ F_2(s) &= \frac{[\Phi(s) - \alpha(s)E(s)]}{[\beta(s) - \alpha(s)W_0(s)]}, \\ I &= I_1 + I_2 + \frac{r}{j} \int_{-j\infty}^{+j\infty} \left[\left| \frac{\Phi(s) - \alpha(s)E(s)}{\beta(s) - \alpha(s)W_0(s)} W_0(s) \right|^2 S_n(s) + \right. \end{aligned} \quad (6)$$

$$\begin{aligned}
& + \left| 1 - \frac{E(s) \beta(s) - W_0(s) \Phi(s)}{\beta(s) - \alpha(s) W_0(s)} \right|^2 S_R(s) ds + \\
& + \frac{c}{j} \int_{-j\infty}^{+j\infty} \left[\left| \frac{E(s) \beta(s) - W_0(s) \Phi(s)}{\beta(s) - \alpha(s) W_0(s)} W_0^{-1}(s) \right|^2 S_R(s) + \right. \\
& \left. + \left| \frac{\Phi(s) - \alpha(s) E(s)}{\beta(s) - \alpha(s) W_0(s)} \right|^2 S_n(s) \right] ds,
\end{aligned}$$

where

$$I_1 = \frac{r}{j} \int_{-j\infty}^{+j\infty} |1 - E(s)|^2 S_q(s) ds; \quad I_2 = \frac{c}{j} \int_{-j\infty}^{+j\infty} |E(s) W_0^{-1}(s)|^2 S_q(s) ds$$

are components that are dependent only on function $E(s)$ and the spectral density of the master signal $S_q(s)$ and $S_R(s)$ and $S_n(s)$ are the spectral noise densities of the error and master signal meters.

Function $\Phi(s)$, which transforms the first variation of functional (6) to zero and which has bands only in the left half-plane s , is determined by the relation

$$\Phi(s) = [B_0(s) + B_+(s)] D^{-1}(s). \quad (7)$$

Here $D(s)$ is a function determined by factorization of the expression

$$[rW_0(s)W_0(-s) + c] [\Delta(s)\Delta(-s)]^{-1} [S_n(s) + S_R(s)] = D(s)D(-s); \quad (8)$$

$B_0(s)$ is an entire part (polynomial of s), $B_+(s)$ is a proper fraction, having bands only in the left half-plane s in the expansion

$$\begin{aligned}
T(s)D^{-1}(s) &= B_0(s) + B_+(s) + B_-(s); \\
T(s) &= E(s) [\Delta(s)\Delta(-s)]^{-1} [rW_0(s)W_0(-s) + c] [\alpha(s)S_n(s) + \\
& + \beta(s)W_0^{-1}(s)S_R(s)] - rW_2(-s)\Delta^{-1}(-s)S_R(s);
\end{aligned} \quad (9)$$

$$\Delta(s) = \beta(s) - \alpha(s)W_0(s). \quad (10)$$

A minimum value of functional (6) is achieved

$$\begin{aligned}
 I_{\min} = & I_1 + I_2 + \frac{1}{j} \int_{-j\infty}^{+j\infty} \left\{ B_-(s) B_-(-s) + \right. \\
 & + \frac{E(s) E(-s) [c + rW_0(s) W_0(-s)]}{[S_R(s) + S_n(s)] W_0(s) W_0(-s)} S_R(s) S_n(s) + \\
 & + rS_R(s) - \frac{rS_R(s) S_n(s) [E(s) + E(-s)]}{[S_R(s) + S_n(s)]} - \\
 & \left. - \frac{r^2 W_0(s) W_0(-s) S_R^2(s)}{[S_R(s) + S_n(s)] [rW_0(s) W_0(-s) + c]} \right\} ds; \quad s = j\omega.
 \end{aligned}$$

Example. Let it be required to design the structure of a regulator $W_1(s)$ and of a filter $W_\Phi(s)$ of the control system of an inertial object with transfer function $W_0(s) = (1 + T_0 s)^{-1}$, combination control of which is achieved by signals from the error meter $\varepsilon(t) = q(t) - q_c(t) + R(t)$ and free gyroscope $q(t) + n(t)$. The system should have first-order astaticism with respect to the master effect, i.e., there should be no static error in the system at constant master signal. This requirement is satisfied most simply when the transfer function is selected in the form $E(s) = (1 + T_E s)^{-1}$. Let us represent the noise of the error meter $R(t)$ in the form of a random steady process of the white noise type with spectral density $S_R = R^2$. The initial error n_0 and its systematic drift $n_1 t$ will be considered as the gyroscope error, i.e.,

$$n(t) = n_0 + n_1 t. \quad (11)$$

The spectral representation of the determinant process (11), according to [3], has the form

$$\begin{aligned}
 S_n(s) = & \lim_{\delta \rightarrow 0} \left\{ \left[\frac{n_0}{(\delta + s)} + \frac{n_1}{(\delta + s)^2} \right] \left[\frac{n_0}{\delta - s} + \frac{n_1}{(\delta - s)^2} \right] \right\} = \\
 & = \frac{(n_1^2 - n_0^2 s^2)}{(-s)^2 (s)^2}.
 \end{aligned}$$

Since the solution of the design problem is independent of the type of polynomials $\alpha(s)$ and $\beta(s)$ [1], it is convenient to assume that $\alpha(s) = 0$ and $\beta(s) = 1$, and then $\Delta(s) = 1$. Substituting the necessary data into (7)-(10), we find

$$D(s) = (\theta + \gamma s) (Rs^2 + ys + n_1) (1 + T_0 s)^{-1} s^{-2}.$$

Here

$$\begin{aligned} \theta &= (c + r)^{\frac{1}{2}}; \quad \gamma = c^{\frac{1}{2}} T_0; \quad y = (2Rn_1 + n_0)^{\frac{1}{2}}; \quad T(s) = R^2 (c - \\ &- rT_0 s - \gamma^2 s^2) (1 - T_0 s)^{-1} (1 + T_E s)^{-1}; \\ B_0(s) + B_+(s) + B_-(s) &= T(s) D(-s)^{-1} = \\ &= \frac{R^2 (c - rT_0 s - \gamma^2 s^2) (-s)^2}{(1 + T_E s) (\theta - \gamma s) (Rs^2 + ys + n_1)} = \\ &= B_0 + \frac{A_1}{(1 + T_E s)} + \frac{A_2}{(\theta - \gamma s)} + \frac{(A_3 s + A_4)}{(Rs^2 + ys + n_1)}; \\ \Phi(s) = [B_0(s) + B_+(s)] D(s)^{-1} &= \frac{(b_0 + b_1 s) (1 + T_0 s) s^2}{T_E (1 + T_E s) (\theta + \gamma s) (Rs^2 + ys + n_1)} \end{aligned}$$

where $b_0 = R\gamma + A_1 T_E$; $b_1 = R\gamma T_1$; $A_1 = R^2 (\theta T_E - \gamma) T_E^{-1} (n_1 T_E^2 + y T_E + R)^{-1}$.

The final purpose is to determine the transfer functions of the regulator $W_1(s)$ and filter $W_\Phi(s)$, which are related to the introduced function $\Phi(s)$ by the relations

$$\begin{aligned} W_1(s) &= \frac{[E(s)\beta(s) - W_0(s)\Phi(s)]}{W_0(s)\{\beta(s)[1 - E(s)] + W_0(s)[\Phi(s) - \alpha(s)]\}}, \\ W_\Phi(s) &= \frac{[\Phi(s) - \alpha(s)E(s)]}{W(s)\{W_0(s)[\Phi(s) - \alpha(s)] + \beta(s)[1 - E(s)]\}}. \end{aligned} \quad (12)$$

Substituting the necessary data into (12), we write

$$\begin{aligned} W_\Phi(s) &= \frac{s(1 + T_0 s)(b_0 + b_1 s)}{T_E^2 (0 + \gamma s) (Rs^2 + ys + n_1) + s(b_0 + b_1 s)}; \\ W_1(s) &= \frac{(1 + T_0 s) [f_2 s^2 + f_1 s + f_0]}{s(\theta + \gamma s) (Rs^2 + ys + n_1) + s(b_0 + b_1 s)}, \end{aligned}$$

where $f_2 = T_E(R\theta + y\gamma - A_1) - R\gamma$; $f_1 = T_E(y\theta + \gamma n_1)$; $f_0 = T_E \theta n_1$.

The minimum value of the variance of error of the designed follow-up system will occur in the absence of constraints on the mean power of the control signal, at $c = 0$, $r = 1$, and will comprise

$$\langle e^2(t) \rangle_{\min} = I_1 + \frac{1}{j} \int_{-j\infty}^{+j\infty} \{ B_-(s) B_-(-s) + S_R(s) S_n(s) [S_R(s) + S_n(s)]^{-1} [1 + E(s) E(-s) - E(s) - E(-s)] \} ds, \quad s = j\omega.$$

Substituting the necessary data into (13), after integration, we find

$$\langle e^2(t) \rangle_{\min} = I_1 + \frac{RT_E}{y} \left\{ \frac{(y + n_1 T_E) n_0^2 + n_1^2 RT_E}{(R + y T_E + n_1 T_E)^2} + \frac{T_E [y(y + n_1 T_0) - Rc_1]^2 + n_1 (y + n_1 T_0)^2}{(R + y T_E + n_1 T_E)^2} \right\}.$$

The relations found in the article permit one to design physically realizable structures and parameters of the components of combination follow-up systems that guarantee the maximum achievable accuracy in the class of linear stationary systems with combination control.

BIBLIOGRAPHY

1. Aliyev, F. A., V. B. Larin, K. I. Naumenko, and V. N. Suntsev, "Optimizatsiya lineynykh invariantnykh vo vremeni sistem upravleniya" [Optimization of Linear Time-Invariant Control Systems], Kiev, 1978.
2. Besekerskiy, V. A. and Ye. P. Popov, "Teoriya sistem avtomaticheskogo regulirovaniya" [Theory of Automatic Control Systems], Moscow, 1972.
3. Newton, J. K., L. A. Gould, and J. P. Kaiser, "Teoriya lineynykh sledyashchikh sistem" [The Theory of Linear Follow-Up Systems], Moscow, 1961.

UDC 681.51

DESIGN OF REGULATOR ACCORDING TO GIVEN CHARACTERISTIC POLYNOMIAL FOR
OBJECTS WITH PERMANENT PERTURBATIONS

907F0290V Kiev MEKHANIKA GIROSKOPICHESKIKH SISTEM in Russian, Issue 8,
1989 (manuscript received 22 Sep 87) pp 96-99

[Article by Yu. V. Morozov, candidate of technical sciences, Kiev
Polytechnical Institute]

[Text] Let us consider a controlled object with perturbations acting on
it, described by a linear matrix differential equation of type

$$\begin{aligned} \dot{x}(t) &= Ax(t) + Bu(t) + F, \\ x(t_0) &= x_0, \quad x \in R^n, \quad u \in R^m, \end{aligned} \quad (1)$$

determined in the open domain $U \subset R^m$. A and B in (1) are constant $n \times n$
and $n \times m$ matrices that characterize the dynamics of the object and the
effectiveness of the control members, respectively, $x(t)$ is a vector of
the phase state with components $x_1(t), \dots, x_n(t)$, $u(t)$ is a control
vector with components $u_1(t), \dots, u_m(t)$, F is a n -dimensional vector of
constant perturbations, and x_0 is a n -dimensional vector of the initial
state.

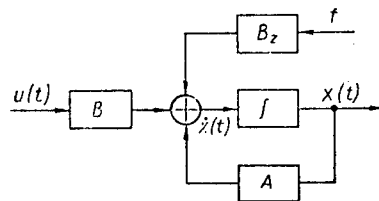

A block diagram of the system, corresponding to equations (1), is
presented in the figure.

Solution of the problem of designing a regulator consists in determination of the control law $u(t)$, which establishes the values of the control actions as a function of the phase vector [1]. Let us use the canonical representation of initial system (1) to design this regulator, as was done in [2] for the special case.

Design. Let us assume that the phase vector $x(t)$ is measured and that system (1) is controllable. After substitution of the variables according to the formula

$$z(t) = Px(t), \quad (2)$$

where P is a constant $n \times n$ matrix, system (1) can be written in the following canonical form:

$$\begin{pmatrix} \dot{z}_1(t) \\ \dot{z}_2(t) \end{pmatrix} = \begin{pmatrix} 0 & E_1 \\ \bar{A}_{21} & \bar{A}_{22} \end{pmatrix} \begin{pmatrix} z_1(t) \\ z_2(t) \end{pmatrix} + \begin{pmatrix} 0 \\ E_2 \end{pmatrix} u(t) + \begin{pmatrix} \bar{F}_1 \\ \bar{F}_2 \end{pmatrix}, \quad (3)$$

where \bar{A}_{21} is a $m \times m$ matrix, \bar{A}_{22} is a $m \times n - m$ matrix, E_1 and E_2 are unit $n - m \times n - m$ and $m \times m$ matrices, respectively, and $z_1(t)$ and $z_2(t)$ are vector columns of dimension m , $n - m$.

We note that the linear nondegenerate transform of coordinates (2) in the space of states of the linear system corresponds to ordinary methods of transformation of the block diagrams in automatic control theory. To find the law of control $u(t)$, let us differentiate system (3) and let us substitute the variables $y_1(t) = z_1(t)$, $y_2(t) = \dot{z}_1(t)$, $y_3(t) = \dot{z}_2(t)$, then

$$\begin{pmatrix} \dot{y}_1(t) \\ \dot{y}_2(t) \\ \dot{y}_3(t) \end{pmatrix} = \begin{pmatrix} 0 & E & 0 \\ 0 & 0 & E \\ 0 & \bar{A}_{21} & \bar{A}_{22} \end{pmatrix} \begin{pmatrix} y_1(t) \\ y_2(t) \\ y_3(t) \end{pmatrix} + \begin{pmatrix} 0 \\ 0 \\ E \end{pmatrix} \dot{u}(t). \quad (4)$$

System (4) still does not yield a simple method of finding the law of control. To achieve this, let us introduce the new control vector

$\xi(y, \dot{u})$ by the formula

$$\xi(t) = \bar{A}_{21}y_1(t) + \bar{A}_{22}y_2(t) + \dot{u}(t). \quad (5)$$

Let

$$\xi(t) = -\bar{K}_1 y_1(t) - \bar{K}_2 y_2(t) - \bar{K}_3 y_3(t), \quad (6)$$

and \bar{K}_i ($i = 1, 2, 3$) are $m \times m$, $m \times m$ and $m \times n - m$ matrices, respectively.

We find from expression (5) with regard to equality (6)

$$\dot{u}(t) = -\bar{K}_1 y_1(t) - (\bar{K}_2 + \bar{A}_{21}) y_2(t) - (\bar{K}_3 + \bar{A}_{22}) y_3(t). \quad (7)$$

Having substituted expression (7) into systems (4), we find a closed object + regulator system of type

$$\begin{pmatrix} \dot{y}_1(t) \\ \dot{y}_2(t) \\ \dot{y}_3(t) \end{pmatrix} = \begin{pmatrix} 0 & E & 0 \\ 0 & 0 & E \\ -\bar{K}_1 & -\bar{K}_2 & -\bar{K}_3 \end{pmatrix} \begin{pmatrix} y_1(t) \\ y_2(t) \\ y_3(t) \end{pmatrix}, \quad (8)$$

where blocks \bar{K}_1 and \bar{K}_2 have dimension $m \times m$, while block \bar{K}_3 has dimension $m \times n - m$. Integration of expression (7) in variables $z_i(t)$ ($i = 1, 2$) yields

$$u(t) = -\bar{K}_1 \int_0^T z_1 dt - (\bar{K}_2 + \bar{A}_{21}) z_1(t) - (\bar{K}_3 + \bar{A}_{22}) z_2(t). \quad (9)$$

Let us represent the matrix of transform P as a block matrix to derive the law of control (9) in the initial variables. Expression (2) then assumes the form $z_1(t) = P_{11} x_1(t) + P_{12} \dot{x}_2(t)$, $z_2(t) = P_{21} x_1(t) + P_{22} \dot{x}_2(t)$.

Let us substitute the values of variables into expression (9) and, reducing similar terms, we find

$$u(t) = -\|\bar{K}_1 P_{11} \mid \bar{K}_1 P_{12}\| \begin{pmatrix} \int_0^T x_1 dt \\ \int_0^T x_2 dt \end{pmatrix} - [(\bar{K}_2 + \bar{A}_{21}) P_{11} + (\bar{K}_3 + \bar{A}_{22}) \times \quad (10)$$

$$\times P_{21}] x_1(t) - [(\bar{K}_2 + \bar{A}_{21}) P_{12} + (\bar{K}_3 + \bar{A}_{22}) P_{22}] x_2(t),$$

or in more compact form

$$u(t) = -K_1 x(t) - K_2 \int_0^T x dt, \quad (11)$$

where

$$K_1 = \| \bar{K}_2 + \bar{A}_{21} \mid \bar{K}_3 + \bar{A}_{22} \| P; \quad (12)$$

$$K_2 = \| \bar{K}_1 P_{11} \mid \bar{K}_1 P_{12} \|, \quad (13)$$

P_{11} is a $m \times m$ matrix and P_{12} is a $m \times n - m$ matrix.

The derived law of control of the regulator uses no information about the perturbation vector.

The first term of expression (11) is the law of control of proportional regulation and can be found independently of the perturbations acting on the object.

Let us again return to system (4). Our problem with respect to vector $y(t) = (y_1(t), y_2(t), y_3(t))$ includes the fact of guaranteeing $y(t) \rightarrow 0$ at $t \rightarrow \infty$ from any initial states $y(0)$. These conditions can be fulfilled if pair $\{A, B\}$ is controllable [1]. The derived law of control permits one to change the dynamics of closed system (8), selecting coefficients \bar{K}_i ($i = 1, 2, 3$) of the law of control of type (6).

Having substituted (11) into initial system (1), we find a closed perturbed system, consisting of an object and regulator:

$$\dot{x}(t) = [A - BK_2] x(t) - BK_1 \int_0^T x dt + F. \quad (14)$$

The law of control (11), which guarantees given dynamics to closed system (14), can be designed by using canonical representation of the initial system in the form of (8).

BIBLIOGRAPHY

1. Andreyev, Yu. N., "Upravleniye konechnomernymi lineynymi obyektami" [Control of Finite-Dimensional Linear Objects], Moscow, 1976.
2. Morozov, Yu. V., "Design of a Stabilization Automaton for a Linear Stationary System, Affected by Constant Perturbations," KIBERNETIKA I VYCHISLITELNAYA TEKHNIKA, No 37, 1977.

UDC 629.7.05(075.8)

ALGORITHM FOR FORMULATION OF ORIENTATION VECTOR OF MOVING OBJECT,
INVARIANT TO CONSTANT A PRIORI DATA ERROR

907F0290W Kiev MEKHANIKA GIROSKOPICHESKIKH SISTEM in Russian, Issue 8,
1989 (manuscript received 11 Nov 87) pp 99-103

[Article by M. A. Pavlovskiy, doctor of technical sciences, G. Ye. Anupriyenko, scientific associate, and A. N. Klimenko, candidate of technical sciences, Kiev Polytechnical Institute]

[Text] The continual increase of technical requirements on the accuracy of spatial orientation of moving objects makes the problem of working out algorithms for formulation of the components of the phase orientation vector timely with respect to signals of the discrete spatial position sensor, mounted on a movable object, the body of which is deformed. This causes the appearance of signals of the sensor with amplitude comparable to the permissible orientation error. An algorithm is known that permits one to formulate current values of the phase orientation coordinates of the body of the object in case of small deviations from the required spatial position and in the case of small absolute values of angular rotational velocity [1] (the spatial rotation of the object about the center of mass is described with sufficient accuracy by three mutually independent plane revolutions with respect to the principal axes of inertia of the body of the object). This algorithm assumes that the acceleration of the object ϵ_y , ϵ_B , caused by the effect of the controlling and perturbing moments, is given. Therefore, it is suggested that the parameters ϵ_y and ϵ_B be identified periodically by an algorithm according to the data in [1]. It is obvious that interruption of the orientation process, caused by the need to identify parameters ϵ_y and ϵ_B , is insufficient.

Let us study the effect of the constant error of a priori data on the accuracy of formulation of current values of phase coordinates by the mentioned algorithm.

The equations of plane rotations of the object with respect to one of its principal axes and the corresponding equations of the filter have the form

$$\dot{X} = AX + B\epsilon; \quad (1)$$

$$\begin{aligned} \dot{\hat{X}} &= A\hat{X} + B\bar{\epsilon} + K(Z - E\hat{X}); \\ A &= \begin{bmatrix} 0 & 1 \\ 0 & 0 \end{bmatrix}; \quad B = \begin{bmatrix} 0 \\ 1 \end{bmatrix}; \quad \bar{\epsilon} = (M_y + M_b)I^{-1}; \quad Z = EX + \xi; \end{aligned} \quad (2)$$

$$\hat{X}^T = (\hat{X}_1, \hat{X}_2); \quad X = (X_1, X_2); \quad E = (1, 0); \quad K^T = (K_1, K_2). \quad (3)$$

Here M_y and M_b are the controlling and perturbing moments, respectively, applied to the object along the control axis, I is the moment of inertia of the object with respect to the control axis, X and \hat{X} are the phase vector and estimation of it, respectively, X_1 and X_2 are the angle and angular rotational velocity of the body of the object with respect to the control axis, K is the filter feedback coefficient, ξ is the noise component of the data to be measured, ϵ is rotational acceleration of the object, $\bar{\epsilon} = \epsilon + \delta\epsilon$ is information about the angular acceleration of the object to be used in the filter, and $\delta\epsilon$ is the constant error.

Since the influence of the error $\delta\epsilon$ on the accuracy of estimating the phase vector must be determined, let us subsequently assume that the noise component of the data to be measured is equal to zero. Eliminating Z from equation (2) and subtracting (2) from equation (1), we find

$$\dot{\tilde{X}} = (A - KE)\tilde{X} - B\delta\epsilon. \quad (4)$$

Since $B\delta\epsilon = \text{const}$, for the steady mode from equation (4) follows

$$\tilde{X} = -(A - KE)^{-1}B\delta\epsilon. \quad (5)$$

Finally from (5) we find

$$\tilde{X}_{1ycr} = \frac{1}{K_2} \delta\epsilon; \quad \tilde{X}_{2ycr} = \frac{K_1}{K_2} \delta\epsilon. \quad (6)$$

Thus, the output of filter (2) will contain an estimation error caused by inaccuracy of the a priori-given data on the external moment applied to the object with respect to the control axis. It follows from relations (6) that the error in estimating the phase coordinates is proportional to the data error $\delta\epsilon$ about the acceleration of the object. Estimation error (6) can be minimized using a refinement of the current value of ϵ with respect to the orientation device [1]. On the other hand, due to the inevitable measurement errors, contained in the instrument readings, the constant component of estimation error (6) can not be completely eliminated within the considered algorithm. This deficiency can be corrected in the following manner. Let us write the equation of motion in the object in the form

$$\dot{X} = AX + B\bar{\epsilon}; \quad A = \begin{bmatrix} 0 & 1 & 0 \\ 0 & 0 & 1 \\ 0 & 0 & 0 \end{bmatrix}; \quad B = \begin{bmatrix} 0 \\ 1 \\ 0 \end{bmatrix}; \quad X = (X_1, X_2, X_3), \quad (7)$$

where $X_3 = \delta\epsilon$.

In scalar form $\dot{X}_1 = X_2$, $\dot{X}_2 = X_3 + \bar{\epsilon}$, $\dot{X}_3 = 0$.

The corresponding equation of the filter has the form

$$\begin{aligned} \dot{\hat{X}} &= AX + B\bar{\epsilon} + K(Z - E\hat{X}); \quad Z = EX + \xi; \\ E &= (1, 0, 0); \quad \hat{X}^T = (X_1, X_2, X_3); \quad K^T = (K_1, K_2, K_3); \quad \xi^T = (\xi_1, 0, 0). \end{aligned} \quad (8)$$

Using the known method of [2], it is easy to ascertain the total observability of system (7) and (8). The equation for it with respect to the estimation error, which is found by subtracting (8) from equation (7) has the form $\dot{\tilde{X}} = (A - KE)\tilde{X}$. It is obvious that $\tilde{X} = 0$ in the steady mode, i.e., $\hat{X}_1 = X_1$, $\hat{X}_2 = X_2$, $\hat{X}_3 = \delta\epsilon$. Thus, filter (8), unlike filter (2), has no constant components of the error in estimation of the phase orientation vector.

It should be noted that actuating members, having static relay characteristic and operating in the pulsed mode, are ordinarily used in real control systems of movable objects. The perturbing moment is a slowly variable time function and can be assumed constant with

sufficient accuracy with regard to the length of the accurate orientation mode. In this case ϵ is a piecewise constant value.

Accordingly, the real value of the error of a priori data will prevent discontinuities of second kind at moments of variation of state of the actuating member. It is obvious that this operating mode of the control system causes fluctuations of the observed values of the phase vector with respect to its real value. The amplitude of these fluctuations will be determined mainly by the inertial properties of the observer, while the frequency will be determined by the frequency of variation of state of the actuating member. The dynamic characteristics of these fluctuations are minimized during design of an observer [1]. The motion of the specific control system, into the circuit of which observer (8) is introduced, was studied by the mathematical modeling method.

The model of the control process included models of the orientation device, filter, control signal shaping module, actuating member and object. The model of the orientation device was programmed in the form

$$\text{of operators } US = KR * FI, \quad \dot{UD} = UD * EXR(-H/TP) + US * (1 - EXP(-H/TP)),$$

where US and FI are the output and input values of the static characteristic of the device, respectively, KR is the characteristic slope of the characteristic of the device, UD is the output of the orientation device, and H and TR are the integration step and time constant of the device.

The model of the filter was programmed in the form

$$\begin{aligned} X1 &= X(1), \\ X(1) &= X(1) + H * (X(2) + K(1) * (FIF - X1)), \\ X(2) &= X(2) + H * (X(3) + E + K(2) * (FIF - X1)), \\ X(3) &= X(3) + H * K(3) * (FIF - X1), \end{aligned}$$

where X is the file of the estimates of angle, angular velocity and $\delta\epsilon$, K is the file of the filter feedback coefficients, FIF is the output of the orientation device, reduced to the dimensionality of the angle, and $E = \epsilon + \delta\epsilon$ is the anticipated value of the angular acceleration of the object on a given integration step.

The model of the control signal shaping module (BFUS) is a mathematical description of a three-position relay with hysteresis, the input of which is a linear combination of estimates of the angle and angular velocity of rotation of the object. The model of the BFUS was programmed in the following form:

$$\begin{aligned} SIG &= K1 * X(1) + K2 * X(2), \\ IF (ABS(SIG) \cdot LT \cdot SO) F &= 0, \\ IF (ABS(SIG) \cdot GT \cdot SS) F &= SIGN(1., SIG), \end{aligned}$$

where SO and SS are the start and response thresholds, respectively, of the relay, and F is the output of the BFUS.

A model of the actuating member (of the electric flywheel motor--EMD) was represented by operators $M = -MY * F + MS$, $MD = MD * \exp(-H/TD) + M * (1 - \exp(-H/TD))$, where M is the anticipated value of the control moment at the given integration step, MY and MS are values of the starting moment of the EMD and of the moment of resistance, respectively, and MD is the moment of the EMD at a given integration step.

According to equation (1), the model of the object was represented in the form of operators

$$FI = FI + FIT * H + (MD/I * H ** 2/2., \\ FIT = FIT + (MD/I) * H,$$

where FIT and FI are the angular velocity and angular rotational coordinate of the object, respectively, and I is the moment of inertia of the object with respect to the control axis.

The results of simulation showed that estimates of the components of the phase orientation vector \hat{X}_1 and \hat{X}_2 fluctuate with respect to the estimated values with amplitude not exceeding 15 percent. There is no constant error component. The accuracy of orientation of the object, controlled by using estimates of the orientation vector, formulated by filter (8), and by using ideally accurate values of the phase orientation vector, essentially coincide.

BIBLIOGRAPHY

1. Pavlovskiy, M. A. and A. N. Klimenko, "Computer Programs of Automated Control System for Precision Orientation of a Solid," MEKHANIKA GIROSKOPICHESKIKH SISTEM, No 3, 1984.
2. Kozlov, V. I., "Sistemy avtomaticheskogo upravleniya letatelnyimi apparatami" [Automatic Control Systems of Air/Spacecraft], Moscow, 1979.

UDC 581.383

GENERAL SOLUTION OF PROBLEM OF THEORY OF ELASTICITY OF ROTATING MEDIUM

907F0290X Kiev MEKHANIKA GIROSKOPICHESKIKH SISTEM in Russian, Issue 8, 1989 (manuscript received 4 Nov 87) pp 103-106

[Article by S. A. Sarapulov, candidate of technical sciences, Kiev Polytechnical Institute]

[Text] Let us consider in this paper the generalization of the Lamé theorem [1] for the problem of the theory of elasticity of a rotating medium. These problems were analyzed earlier only by the perturbation method [2, 3] or by other approximation methods.

The effect of rotation of an elastic medium as a whole on vibrations is reflected in the equations of motion, having connected after d'Alembert the inertial loads in a rotating coordinate system:

$$(\lambda + 2\mu) \nabla (\nabla \cdot \vec{u}) - \mu \nabla \times (\nabla \times \vec{u}) = \rho (\vec{F} + \ddot{\vec{u}} + 2\vec{\Omega} \times \dot{\vec{u}} + \dot{\vec{\Omega}} \times \vec{u}) + o(\Omega^2), \quad (1)$$

where $\vec{\Omega} = \{\Omega_x, \Omega_y, \Omega_z\}$ is the angular rotational velocity of a body as an absolute solid, $\vec{u} = \{u_x, u_y, u_z\}$ is the vector of elastic displacements, \vec{F} is the load vector, and λ and μ are Lamé constants.

Let us assume that servocoupling in the form of a torque which compensates the effect of elastic vibrations on rotation at angular velocity--a given time function--is applied to the body.

According to Helmholtz's theorem, representation in the form of the sum of the potential and eddy parts of the field $\vec{u} = \vec{u}_1 + \vec{u}_2$, $\nabla \times \vec{u}_1 = 0$,

$\nabla \cdot \vec{u}_2 = 0$ is valid, and this representation is unique. It is equivalent

to $\vec{u}_1 = \nabla \varphi$, $\vec{u}_2 = \nabla \times \vec{\psi}$, where φ and $\vec{\psi}$ are the scalar and vector

potentials. In similar fashion, $\vec{F} = \nabla U + \nabla \times \vec{A}$. Substitution of the

expansions into (1) yields $(\lambda + 2\mu) \nabla \times \nabla (\nabla \cdot \vec{u}_i) - \mu \nabla \times (\nabla \times \vec{u}_i)$. for the left side of the equations of motion. We find $\Delta = \nabla (\nabla \cdot) - \nabla \times$ with regard to the identity $(\lambda + 2\mu) \Delta \vec{u}_i - \mu \Delta \vec{u}_i (\nabla \times)$.

The terms of the last equation are an expansion of the left side onto the potential and eddy components: $(\lambda + 2\mu) \nabla \cdot (\Delta \varphi) - \mu \nabla \times (\Delta \vec{\psi})$.

Let us write the right side of equations (1) in the form of a similar expansion. Let us make the transformations on the example of the

component $(\vec{H} \times \vec{u})_x$, where $\vec{H} = 2\vec{\Omega} \partial_t + \partial_t \vec{\Omega}$;

$$(\vec{H} \times \vec{u})_x = H_y u_z - H_z u_y = (-H_y \psi_y - H_z \psi_z)_{,x} + (-H_z \varphi + H_y \psi_x)_{,y} + (H_y \varphi + H_z \psi_x)_{,z}.$$

In view of $\vec{\nabla} \cdot \vec{\psi} = 0$ --the constraints which can be imposed on the vector potential (it will be determined with accuracy up to a time function),

we write $(\vec{H} \times \vec{u})_x = (H_x \psi_x - H_y \psi_y - H_z \psi_z)_{,x} + (H_x \psi_y - H_z \varphi + H_y \psi_x)_{,y} + (H_x \psi_z + H_y \varphi + H_z \psi_x)_{,z}$.

We represent the other components of $\vec{H} \times \vec{u}$ in similar fashion. Integrating and omitting the additive time function, we find

$$\begin{aligned} c_l^2 \Delta \varphi &= \ddot{\varphi} + \vec{H} \cdot \vec{\psi} + U, \\ c_l^2 \Delta \vec{\psi} &= \ddot{\vec{\psi}} + \vec{H} \times \vec{\psi} - \vec{H} \varphi + \vec{A}, \end{aligned} \quad (2)$$

where $c_l = \sqrt{\frac{\lambda + 2\mu}{\rho}}$, $c_t = \sqrt{\frac{\mu}{\rho}}$ is the speed of sound.

Let the boundary value problem be solved for a fixed medium and let the functions $\Delta F_\chi = \chi F_\chi$, be found, which determine the solution $\varphi = p_0(t) F_\chi$, $\vec{\psi} = \vec{p}(t) F_\chi$ at $U = f_0(t) F_\chi$, $\vec{A} = \vec{f}(t) F_\chi$. Then upon rotation

$$\begin{aligned} \ddot{p}_0 + \vec{H} \cdot \vec{p} &= c_l^2 \chi p_0 + f_0, \\ \ddot{\vec{p}} + \vec{H} \times \vec{p} - \vec{H} p_0 &= c_l^2 \chi \vec{p} + \vec{f} \end{aligned} \quad (3)$$

or in the form of a quaterion equation

$$\ddot{q} + H0q = Aq + g, \quad (4)$$

where $q = (\rho_0 \vec{\rho})$; $H = (0\vec{H})$; $g = (f_0 \vec{f})$.

Let us consider the special case of rotation about a fixed axis.

Without limiting generality, let us assume that $\Omega_x = \Omega$, $\Omega_y = \Omega_z = 0$,

$H_x = H$. Then (3) can be represented in the form of the direct sum of the subsystem

$$\begin{aligned} \ddot{\rho}_0 - c_i^2 \chi \rho_0 - H \rho_x &= f_0, \\ \ddot{\rho}_x - c_i^2 \chi \rho_x + H \rho_0 &= f_x \end{aligned}$$

and of a subsystem similar to a Foucault pendulum

$$\begin{aligned} \ddot{\rho}_y - c_i^2 \chi \rho_y - H \rho_z &= f_y, \\ \ddot{\rho}_z - c_i^2 \chi \rho_z + H \rho_y &= f_z. \end{aligned}$$

In the case of the plane problem of elasticity theory [1]

$$\begin{aligned} u_{,xx} + \frac{1-\nu}{2} u_{,yy} + \frac{1+\nu}{2} v_{,xy} &= Du - H_* v, \\ \frac{1-\nu}{2} v_{,xx} + v_{,yy} + \frac{1+\nu}{2} u_{,xy} &= Dv + H_* u \end{aligned} \quad (5)$$

(here $D = \partial_\tau^2 - \Omega_*^2$; $H_* = 2\Omega_* \partial_\tau + \partial_\tau \Omega_*$; $\Omega_* = \left(\frac{E}{(1-\nu^2)\rho} \right)^{\frac{1}{2}} \Omega$; $\tau = \frac{E}{(1-\nu^2)\rho} t$;

and E and ν are Young's modulus of first kind and Poisson's coefficient)

similar results can be found with respect to functions $\epsilon = \frac{1}{2}(u_{,x} + v_{,y})$,

$\gamma = \frac{1}{2}(v_{,x} - u_{,y})$, if the operations of taking the divergence of the rotor

as well are applied to (5). Then

$$\begin{aligned}\Delta\varepsilon &= D\varepsilon - H_*\gamma, \\ (1-\nu)\Delta\gamma &= D\gamma + H_*\varepsilon,\end{aligned}\tag{6}$$

and if one assumes that $\varepsilon = p_x(t)F_x$, $\gamma = q_x(t)F_x$, then from (6) follows

$$\begin{aligned}Dp_x - H_*q_x + \chi p_x &= 0, \\ Dq_x + H_*p_x + (1-\nu)\chi q_x &= 0.\end{aligned}\tag{7}$$

It is easy to find the solution of (7) similar to Foucault's pendulum at $\nu = 0$ and at arbitrary function $\Omega(t)$. The characteristic equation of system (7) has the form $(\chi - \Omega_*^2 - \omega_*^2)((1-\nu)\chi - \Omega_*^2 - \omega_*^2) - 4\Omega_*^2\omega_*^2 = 0$, at $\Omega = \text{const}$, while the solution is

$$p_x(t) = P_x e^{i\omega_*\tau} + \text{K. c.}, \quad q_x(t) = Q_x e^{i\omega_*\tau} + \text{K. c.}$$

This solution is specifically applicable to the problem of vibrations of a disk in its own plane [1].

In the case of fluctuations of a thin ductile ring in its own plane, the solution of the equations of motion [4]

$$\begin{aligned}\partial^2(\partial w + v) + \frac{1}{\varepsilon} \partial(\partial v - w) &= Dv - H_*w, \\ -\partial^3(\partial w + v) + \frac{1}{\varepsilon}(\partial v - w) &= Dw + H_*v\end{aligned}\tag{8}$$

(here $\Omega_* = \frac{\Omega}{k}$; $\tau = kt$; $k^2 = \frac{EJ}{\rho R^4 S}$; $\varepsilon = \frac{1}{12} \left(\frac{h}{R}\right)^2$ J and S are the moment of inertia and cross-sectional area of the ring, R and h are the radius of the mid-line and thickness of the ring, v and w are components of the vector of displacements of the points of the mid-line in polar coordinates, and $\partial = \frac{\partial}{\partial \alpha}$) can be found in the form

$$\begin{aligned}v &= p'_n(t) \cos n\varphi + q'_n(t) \sin n\varphi, \\ w &= q''_n(t) \cos n\varphi + p''_n(t) \sin n\varphi.\end{aligned}\tag{9}$$

Having substituted (9) into (8) and having omitted subscript n , we find

$$\begin{aligned}
 Dp' - Hq'' + a_1 p' + ap'' &= 0, \\
 Dq' - Hp'' + a_1 q' - aq'' &= 0, \\
 Dq'' + Hp' + a_2 q'' - aq' &= 0, \\
 Dp'' + Hq' + a_2 p'' + ap' &= 0,
 \end{aligned}
 \tag{10}$$

where $a_1 = n^2 \left(1 + \frac{1}{\epsilon}\right)$; $a_2 = n^4 + \frac{1}{\epsilon}$; $a = n \left(n^2 + \frac{1}{\epsilon}\right)$.

It is easy to analyze the dependence of the solution of system (10) on the small parameter ϵ by the perturbation method at $\Omega = \text{const}$ [5].

Thus, if the classical problem of elasticity theory is solved, the problem reduces to analysis of an ordinary quaternion equation (4) upon rotation. Therefore, the results permit one to construct generalizations of known problems on surface and volumetric waves, and vibrations of disks, cylinders, and rings.

BIBLIOGRAPHY

1. Lyav, A., "Matematicheskaya teoriya uprugosti" [Mathematical Theory of Elasticity], Moscow-Leningrad, 1935.
2. Dahlen, F. A., "The Normal Modes of a Rotating Elliptical Earth," GEOPHYSICS JOURNAL OF ROYAL ASTRONOMICAL SOCIETY, Vol 16, No 3, 1968.
3. Idem, "The Normal Modes of a Rotating Elliptical Earth. II. Near-Resonance Multiplet Coupling," Ibid., Vol 18, No 3, 1969.
4. Zhuravlev, V. F. and D. M. Klimov, "Volnovoy tverdotelnyy giroskop" [A Solid-State Wave Gyroscope], Moscow, 1985.
5. Nayfe, A. Kh., "Vvedeniye v metody vozmushcheniy" [Introduction to Perturbation Methods], Moscow, 1984.

UDC 531.01:513.83

MANIFOLD PROPERTIES OF ONE CLASS OF NON-AUTONOMOUS SYSTEMS

907F0290Y Kiev MEKHANIKA GIROSKOPICHESKIKH SISTEM in Russian, Issue 8, 1989 (manuscript received 12 Nov 87) pp 107-112

[Article by N. S. Sivov, doctor of technical sciences, and M. K. Sparavalo, post-graduate student, Kiev Polytechnical Institute]

[Text] A non-autonomous system, described by differential equations of the following type, is given

$$dx/dt = f(t, x), \quad (1)$$

where $x = (x_1, \dots, x_n)^T$ is a n -dimensional phase vector, $f(t, x) = (f_1(t, x), \dots, f_n(t, x))^T$ is a vector function, and $f_i(t, x) \in C^r(R \times R^n, R)$, $i = (1, \dots, n)$, $r \geq 2$; $\Delta = [t_0; t_1]$ is a finite time segment, and $t_0 < t_1 < +\infty$.

Let us consider along with them the following system of equations:

$$f_k(t, x) = 0, \quad k = (1, \dots, L), L \leq n; \quad (2a)$$

$$dx_m/dt = f_m(t, x), \quad m = (L + 1, \dots, n). \quad (2b)$$

Let $x'(t)$ be a solution of system (2) for

$$x'_m(t_0) \in X_0^{n-1} (X_0^{n-1} \subset R^{n-1}, t \in \Delta), \quad (3)$$

while $x(t)$ is the solution of systems (1) for

$$\begin{aligned}
 x(t_0) &= x'_m(t_0), \quad m = (l+1, \dots, n), \\
 x_i(t_0) &\in X_0^n, \quad X_0^n \in \Pi, \quad i = (1, \dots, n),
 \end{aligned}
 \tag{4}$$

where Π is some set and $X_0^n \subset \mathbb{R}^n$ is a set of initial conditions.

Let us find the conditions at which the following inequality is fulfilled for $t \in \Delta_\epsilon$

$$\rho(x'(t), x(t)) = \|x'(t) - x(t)\| \leq \epsilon,
 \tag{5}$$

where $\Delta_\epsilon = [t_\epsilon; t_1]$; $t_0 \leq t_\epsilon < t_1$; $\epsilon > 0$ is a sufficiently small number.

Definition 1. The vector function $x'(t)$ is called the manifold of system (1) at initial conditions (4) if condition (5) is fulfilled.

Definition 2. Points (t, x) of $n+1$ -dimensional space, which form some set E^{n+1} and for which condition (5) is valid, is called the attracting ϵ -neighborhood of manifold $x'(t)$ of system (1).

System (1) can be considered as a one-parameter group of transformations $g^t: X^{n+1} \rightarrow X^{n+1}$ of phase space X^{n+1} , generated by vector field $f(t, x)$, which maps a [translator's note: one word omitted] set $X_0^n (x_i(t_0) \in X_0^n)$ into some finite X_1^n [translator's note: part of item missing]. Let X_1^n be measurable according to Jordan [1].

Definition 3. Manifold system (1) has μ -invariance of finite set X_1^n with respect to some initial X_0^n if: 1) there exists such a moment of time $t_\epsilon \in \Delta$ that all the integral curves emerging from $X_0^n \forall t > t_\epsilon$, belong to E^{n+1} , i.e., $X_1^n \in E^{n+1}$; 2) $\mu X_1^n \leq \nu$, where μ is a n -dimensional Jordan measure, $\nu > 0$ is a sufficiently small number, which is a Jordan measure of the cross-section of set E^{n+1} by hyperplane $T = ((t, x): t - t_1 = 0)$.

Let us introduce the following geometric constructions into consideration. Let there be given hypersurface $S_h = ((\dot{x}_h, t, x): \dot{x}_h - f_h(t, x) = 0)$, where \dot{x}_h is a derivative of function x_h at point (t, x) , be given in space \mathbb{R}^{n+2} . Hypersurface V_h of space \mathbb{R}^{n+1} will be the intersection S_h and hyperplane $U_h = ((\dot{x}_h, t, x): x_h = 0)$. Let us be given the set of dimensionality $n+2$ $G_h^{n+2}(\dot{x}_h, t, x) \subset \mathbb{R}^{n+1}$ such that $G_h^{n+2} \cap S_h \neq \emptyset, V_h \in G_h^{n+2}$.

Let $G_k^{n+2} \cap U_k = \Pi_k^{n+1}(t, x)$ be some set of dimensionality $n + 1$. Hyperplane U_k divided G_k^{n+2} into two sets G_k^+ and G_k^- such that if $S_h \cap G_k^{n+2} \in G_k^+$, then $f_k(t, x) > 0 \forall (t, x) \in \Pi_k^+$; if $S_h \cap G_k^{n+2} \in G_k^-$, then $f_k(t, x) < 0 \forall (t, x) \in \Pi_k^-$, where Π_k^+ and Π_k^- are sets by which Π_k^{n+1} is divided by intersection V_k . Set Π_k^+ is determined as an orthogonal projection of each point $(x_h, t, x) \in (S_h \cap G_k^{n+2})$ onto U_k , for which $\dot{x}_k > 0$; Π_k^- is determined in similar fashion, but with the condition $\dot{x}_k < 0$.

Let us consider hypersurfaces V_k^+ and V_k^- such that if $x(t) \in (V_k^+, V_k^-)$, $x'(t) \in V_k$, then

$$|dx_k(t)/dt| = |dx'_k(t)/dt| \quad \forall t \in \Delta. \quad (6)$$

We shall say that point (t, x) is higher than V_k with respect to U_k , if its coordinate x_k is greater than the corresponding coordinate x'_k of point $(t, x') \in V_k$, found by intersection of straight line P with V_k , where $\langle p, v_h \rangle = 0$, $p \in P$, $v_h \in V_h$, $(t, x) \in P$. In similar fashion, $t(x)$ is found below V_k with respect to U_k , if $x_k < x'_k$. If all the points of some set A lie higher (lower) than V_k , then A is higher (lower) than V_k with respect to U_k . Let us also introduce the definition of motion of integral curve $x(t)$ to some hypersurface B with respect to U_k , if all the points $(t, x) \in x(t)$ are located above (below) B and in this case $x_k(t)$ is a decreasing (increasing) function of t . Let us require that V_k^+ lie above V_k , and let V_k^- lie below V_k with respect to U_k . The following existence theorem is valid.

Theorem. Let $\bigcap_{k=1}^l \Pi_k^{n+1} = \Pi$, where $\Pi \neq \emptyset$ and $t \in \Delta$, $\bigcap_{k=1}^l V_k \neq \emptyset$, $V_h \in \Pi$, $h = (1, \dots, l)$.

for $t \in \Delta$. Then $x(t) \in \mathbb{E}^{n+1}$: upon fulfillment of the following requirements:

a) if the arbitrary point (t, x) of curve $x(t)$ belongs to Π_k^- , it is higher than V_k^+ , and if $(t, x) \in \Pi_k^+$, it is lower than V_k^- :

b) the inequalities $|\dot{f}_h(t, x)| > |dx_k^h/dt|$, $h = (1, \dots, l)$, where $x^k(t) \in V_k$ are valid for point $(t, x) \in x(t)$, located above (below) $V_k^+(V_k^-)$.

Proof. Let us consider the condition when $(t, x) \in x(t)$ belongs to Π_k^- . According to a), point (t, x) lies above V_k^+ . Let us project curved $x(t)$ orthogonally onto U_k . We find part of the cylindrical hypersurface C_k in \mathbb{R}^{n+1} , the generatrices of which are orthogonal to U_k , while the

directrix is a projection of $x(f)$ onto U_k . Let $C_h \cap V_k^+ = x^+(t)$, $C_h \cap V_k = x^k(t)$. The points belonging to $x(t), x^+(t), x^k(t)$ differ only by coordinate x_k , and $x_h(t) > x_k^+(t) > x_k^k(t)$. However, $dx_h/dt = f_h(t, x) < 0$ and, accordingly, $x(t)$ moves toward V_k and V_k^+ with respect to U_k . Let $x_k^+(t) - x_k^k(t) < \delta_k \forall t \in \Delta$, where δ_k is some positive number. Let us consider the difference

$$x_h - x_k^k = x_h(t') - x_k^k(t') + \int_{t'}^t (f_h(t, x) - dx_k^k/dt) dt, t_0 \in [t'; t_1].$$

According to a) and b): $x_h(t') - x_k^k(t') > 0$, $f_h(t, x) - dx_k^k/dt < 0$, while $x_h(t) - x_k^+(t) > 0$. Therefore, either $x(t'_k) \in V_k^+$ at some t'_k or $\lim_{t \rightarrow +\infty} (x_h(t) - x_k^+(t)) = 0$. This means that moment of time t_k^δ is found such that $\forall t_k^\delta \leq t < +\infty |x_h(t) - x_k^k(t)| < \delta_k$, $k = (1, \dots, l)$. The path of the arguments is the same for $(t, x) \in x(t) \in \Pi_k^+$. Let $\forall t \in \Delta_\varepsilon$ ($t_\varepsilon = \max(t_\delta^1, \dots, t_\delta^l)$) $|x_h(t) - x_k^k(t)| < \delta_k$, $k = (1, \dots, l)$. Let us consider the limits $\delta_k \rightarrow 0$, $t_\varepsilon \rightarrow t_0$. We find $x(t) \in V_k$, $k = (1, \dots, l)$ within the limit. Accordingly, the equations of subsystem (2a) are satisfied. Equalities (2b) are fulfilled automatically due to the fact that $x(t)$ is a solution of system (1), while equations (2b) coincide with $n - 1$ last equations (1). Thus, $t_\varepsilon = t_0$, $x(t) = x'(t)$ at $\delta_k = 0$ and one can write $\lim_{\delta \rightarrow 0} x(t) = x'(t)$ or $\lim_{\delta \rightarrow 0} \omega(t, \delta) = 0$, where $\omega(t, \delta) = x(t) - x'(t)$, $\delta = (\delta_1, \dots, \delta_l, t_\varepsilon - t_0)^T$.

Having selected vector δ as sufficiently small, we find ω with small coordinates $\omega_i(f)$ for $t_\varepsilon < t \leq t_1$. Let us assume that $\varepsilon = \|\omega(t, \delta)\|_0$, where $\|\omega(t, \delta)\|_0 = \max_{i=(1, \dots, n)} (\max_{t \in \Delta_\varepsilon} |\omega_i|)$. The following conditions are then fulfilled: $|x_i(t) - x'_i(t)| < \varepsilon \forall t \in \Delta_\varepsilon$, $i = (1, \dots, n)$, i.e., $x(t) \in E^{n+1}$. The theorem is proved..

Let us transform condition b) to a more convenient form. Let the Jacobian $\frac{\partial (f_1, \dots, f_l)}{\partial (x_1, \dots, x_l)} \neq 0 \forall (t, x) \in \Pi$, then according to [2], we find from subsystem (2a) $x_k = \Phi_k(t, x_1, \dots, x_{k-1}, x_{k+1}, \dots, x_n)$, $k = (1, \dots, l)$

The complete differentials are

$$dx_h = \frac{\partial \varphi_h}{\partial t} dt + \sum_{m=1}^n \frac{\partial \varphi_h}{\partial x_m} dx_m. \quad (7)$$

Writing subsystem (2b) by differentials and substituting them into (7), we find

$$dx_h = \left(\frac{\partial \varphi_h}{\partial t} + \sum_{m=1}^n \frac{\partial \varphi_h}{\partial x_m} f_m(t, \mathbf{x}) \right) dt.$$

Now condition b) can be written as follows:

$$|\Gamma_h(t, \mathbf{x})| < |f_h(t, \mathbf{x})| \quad \forall (t, \mathbf{x}) \in \Pi, \quad (8)$$

where $\Gamma_h(t, \mathbf{x}) = \frac{\partial \varphi_h}{\partial t} + \sum_{m=1, m \neq h}^n \frac{\partial \varphi_h}{\partial x_m} f_m(t, \mathbf{x})$.

The equations of hypersurfaces V^+_k and V^-_k have the form

$$|f_h(t, \mathbf{x})| = |\Gamma_h(t, \mathbf{x})|. \quad (9)$$

The following important corollary follows from the theorem. In order for non-autonomous system (1) to have manifold properties with respect to $x'(t)$ according to k equations, it is necessary that

$$\left. \frac{\partial f_k^j(t, \mathbf{x})}{\partial x_k^j} \right|_{\mathbf{x}=\mathbf{x}'(t)} < 0, \quad j = 2r + 1, r = (0, 1, 2, \dots), \quad k = (1, \dots, l). \quad (10)$$

For proof, let us expand function $f_k(t, \mathbf{x})$ in the neighborhood $\mathbf{x}'(t)$ into a series. Let us gather together the terms by odd powers $x_k - x'_k(t)$ and taking into account that $f_k(t, \mathbf{x}'(t)) = 0$, we find

$$f_h(t, \mathbf{x}) = \sum_{j=2r+1} \left. \frac{\partial^j f_h}{\partial x_k^j} \right|_{\mathbf{x}=\mathbf{x}'(t)} (x_k - x'_k(t))^j + R(\mathbf{x} - \mathbf{x}'(t)),$$

$$r = (0, 1, 2, \dots),$$

where $R(x - x'(t))$ are higher-order terms. Hence, condition (10) also follows.

It is obvious that contraction $x(t)$ toward the manifold is reduced, since only in condition (8) the sign of the inequality is replaced by an equality. Since $f_k(t, x)$ approaches zero along the manifold, then the greater $f_k(t, x)$ is, the narrower the attracting ϵ -neighborhood is.

Intersection of hyperplane $T = \{(t, x) : t - t_1 = 0\}$ and of set E^{n+1} forms a closed sphere $B^n(x'(t), \epsilon)$ [3], measurable according to Jordan. Let $\mu B^n = \beta$ and then one can assume that $X^{n_1} = B^n$ and, accordingly, $\mu X^{n_1} = \nu$, where $\nu = \beta$. The property of μ -invariance for systems having manifolds can be used in design of controlled dynamic systems, invariant to initial perturbations.

Example.

$$\frac{d\theta}{dh} = \frac{R + C_Y^\alpha \cdot 0,5\rho v^2 S}{m v^2 \sin \theta} \alpha - \left(\frac{g}{V^2} - \frac{1}{R_3 + h} \right) \text{ctg } \theta; \quad (11)$$

$$\frac{dm}{dh} = - \frac{\beta}{v \sin \theta}, \quad (12)$$

where

$$\alpha = \left(\frac{R - C_{X0} \cdot 0,5\rho v^2 S - (v + g/v) m v \sin \theta}{0,5R + A \cdot 0,5\rho v^2 S} \right)^{\frac{1}{2}}.$$

Table 1

| h | m | θ |
|-----|----------|----------|
| 1,0 | 100,0000 | 0,3190 |
| 1,2 | 99,9226 | 0,2315 |
| 1,4 | 99,8357 | 0,1898 |
| 1,6 | 99,7483 | 0,1853 |
| 1,8 | 99,6678 | 0,1991 |
| 2,0 | 99,5914 | 0,2088 |
| 2,1 | 99,5510 | 0,1769 |

Table 2

| h | $\left. \frac{\partial f_1}{\partial \theta} \right _{\theta=\theta'}^{m=m'(h)}$ |
|-----|--|
| 1,0 | -48,81 |
| 1,2 | -49,17 |
| 1,4 | -48,49 |
| 1,6 | -45,10 |
| 1,8 | -41,35 |
| 2,0 | -39,83 |
| 2,1 | -46,78 |

Table 3

| n | m' | θ' |
|-----|----------|-----------|
| 1,0 | 100,0000 | 0,3252 |
| 1,2 | 99,9220 | 0,2301 |
| 1,4 | 99,8348 | 0,1894 |
| 1,6 | 99,7474 | 0,1856 |
| 1,8 | 99,6670 | 0,1994 |
| 2,0 | 99,5900 | 0,2085 |
| 2,1 | 99,5500 | 0,1751 |

Functions $(R, \rho, v, C_{x0}, C^{\alpha}_r, A, g, \dots)$ are complex functions of h ; therefore, spline interpolation was carried out. The initial system was first reduced to dimensionless form and $m_0 = 100$, $\theta_0 \in [0,03; 0,32]$ was integrated at $h_1 = 1$, $h_2 = 2.1$. The results of integration with initial condition with respect to θ_0 , equal to 0.319, are given in Table 1.

To determine the manifold, let us set $f_1(h, m, \theta)$ equal to 0 and let us find

$$\sin \theta' = \frac{N_2 m' - (N_2^2 m'^2 - 4N_3 m'^2 (N_1 - N_3 m'^2))^{1/2}}{2N_3 m'^2}, \quad (13)$$

where

$$N_1 = \frac{(R + C_Y^{\alpha} \cdot 0,5 \rho v^2 S)^2}{v^4} (R - C_{x0} \cdot 0,5 \rho v^2 S);$$

$$N_2 = \frac{(R + C_Y^{\alpha} \cdot 0,5 \rho v^2 S)^2}{v^3} \left(v + \frac{g}{v} \right);$$

$$N_3 = \left(\frac{g}{v^3} - \frac{1}{R_s + h} \right)^2 (0,5 A \rho v^2 S + 0,5 R).$$

Having substituted (13) into (12), we find the equation for the manifold $(\theta'(h), m'(h))$. Using condition (10), we write

$$\frac{\partial f_1}{\partial \theta} \Big|_{\substack{\theta=\theta'(h) \\ m=m'(h)}} < 0.$$

The results of estimating the order of this value are presented in Table 2.

Let us compile Table 3 for the manifold. As one can see from Tables 1 and 3, the difference in absolute value between variables m and m' , θ and θ' does not exceed 0.001.

The absolute difference θ , m at point $h = 2.1$ did not exceed 0.0075 upon variation of θ_0 in the range of [0.03; 0.32]. Thus, the convergence to the manifold is also good.

BIBLIOGRAPHY

1. Kudryavtsev, L. D., "Kurs matematicheskogo analiza" [Course in Mathematical Analysis], Vol 2, Moscow, 1981.
2. Pontryagin, L. S., "Obyknovennyye differentsialnyye uravneniya" [Ordinary Differential Equations], Moscow, 1970.
3. Kolmogorov, A. N. and S. N. Fomin, "Elementy teorii funktsiy i funktsionalnogo analiza" [Elements of the Theory of Functions and of Functional Analysis], Moscow, 1981.

UDC 531.768

OPTIMIZATION OF QUANTIFICATION PERIOD IN DIGITAL FOLLOW-UP SYSTEM WITH GIVEN DELAY

907F0290Z Kiev MEKHANIKA GIROSKOPICHESKIKH SISTEM in Russian, Issue 8, 1989 (manuscript received 10 Oct 87) pp 112-113

[Article by V. M. Slyusar, candidate of technical sciences, V. V. Tsisarzh, post-graduate student, and V. M. Rechkin, post-graduate student, Kiev Polytechnical Institute]

[Text] The purpose of this article is to study the effect of the delay τ on the maximum bandwidth of a digital follow-up system (TsSS).

To solve the postulated problem, let us introduce into consideration the discrete transfer function of the error of the digital follow-up system, which, according to the expressions found in [1], has the form

$$W_0(z, 0) = q_0(z, 0) q_y^{-1}(z, 0) = [1 + W_p^T(z, 0)]^{-1}; \quad (1)$$

$$W_p^T(z, 0) = (1 - z^{-1}) D(z) Z [W_H(p) e^{-\tau p}]. \quad (2)$$

Here $q_y(z, 0)$ and $q_0(z, 0)$ are the corresponding z -transformations of the control signal; and errors of the digital follow-up system, $W_0(z, 0)$ are the transfer function (digital follow-up system) according to the error signal at moments of closing the pulsed element, $W_p^T(z, 0)$ is the transfer function of an open control circuit, $D(z)$ is the discrete transfer function of the control program, Z is a symbol of z -transformation of the reduced continuous part $W_H(p) = W_0(p)p^{-1}$, and $W_0(p)$ is the transfer function of the continuous control object of the digital follow-up system.

Let us use the method of the modified z -transformation when accounting for the delay τ in the digital follow-up system [2]. This method, with

quantification time $T_0 \geq (\tau + \delta)$, yields the following expression for the transfer function of an open control circuit:

$$W_p^\tau(z, 0) = (z - 1)z^{-2}W^\tau(z, \epsilon); \quad (3)$$

where

$$W^\tau(z, \epsilon) = Z_\epsilon[W_H(p)]; \quad \epsilon = \delta T_0^{-1}; \quad (4)$$

and Z_ϵ is a symbol of modified z-transformation. Let us estimate the bandwidth of the digital follow-up system at known delay τ , having considered the case of a digital follow-up system, of sufficient interest for practice, with continuous control object $W_0(p) = (1 + T_1 p)^{-1}$ and with physically realizable control algorithm $D(z)$, the transfer function of which, when using a bilinear operator $z = (1 + w)(1 - w)$, is represented in the form

$$D(w) = \frac{k(1 + T_4 w)(1 + T_5 w)}{w(1 + T_3 w)}, \quad (5)$$

where T_3 , T_4 , and T_5 are the time constants of the control algorithm. The transfer function of open control circuit (3) of the digital follow-up system with regard to (4) and (5) will then be described by the following expression:

$$W_p^\tau(w) = \frac{k(1 - w)(1 + T_1' w)(1 + T_4 w)(1 + T_5 w)}{w(1 + w)(1 + T_2 w)(1 + T_3 w)}, \quad (6)$$

where $T_1' = (1 + d - 2d^2)(1 - d)^{-1}$; $T_2 = (1 + d)(1 - d)^{-1}$; $d = \exp(-\alpha)$; $\alpha = T_0 T_1^{-1}$; $\epsilon = \delta T^{-1}_0$.

One can show that the transfer function of type

$$W_p^\tau(w) = \frac{k(1 - w) \cdot (1 + T_1' w)}{w(1 + T_3 w)}, \quad (7)$$

which can be found in a digital follow-up system by selecting the time constants of the control algorithm ($T_4 = 1$; $T_2 = T_5$), will be optimal.

It follows from analysis of a stable digital follow-up system with transfer function (7) that the maximum permissible cutoff frequency will be determined by the expression

$$\omega_{cp}(\delta) = \frac{2}{(\tau + \delta)} \operatorname{arctg} \frac{1}{2} \left[1 + \frac{(e^{\sigma\nu} - 1)}{(1 - e^{-\nu})} \right], \quad (8)$$

where $\sigma = \delta\tau^{-1}$; $\nu = \tau T_1^{-1}$.

The maximum permissible cutoff frequency in the digital follow-up system is $\omega_{cp}(0) = 2\tau^{-1} \operatorname{arctg} \frac{1}{2}$ at $\delta = 0$ ($T_0 = \tau$). For convenience of further analysis, let us introduce into consideration the proportionality constant $m = \omega_{cp}(\delta)\omega_{cp}(0)^{-1}$, which, with regard to (8), will have the form

$$m = \frac{1}{(1 + \sigma)} \operatorname{arctg} \frac{1}{2} \left[1 + \frac{(e^{\sigma\nu} - 1)}{(1 - e^{-\nu})} \right] \operatorname{arctg}^{-1} \left(\frac{1}{2} \right). \quad (9)$$

Formula (9) permits one to reach conclusions about the considerable influence of the time constant T_1 of the control object $W_0(p)$ on the proportionality constant with delay τ in the system. The dependence of (9) on parameters σ and ν is shown in the figure.

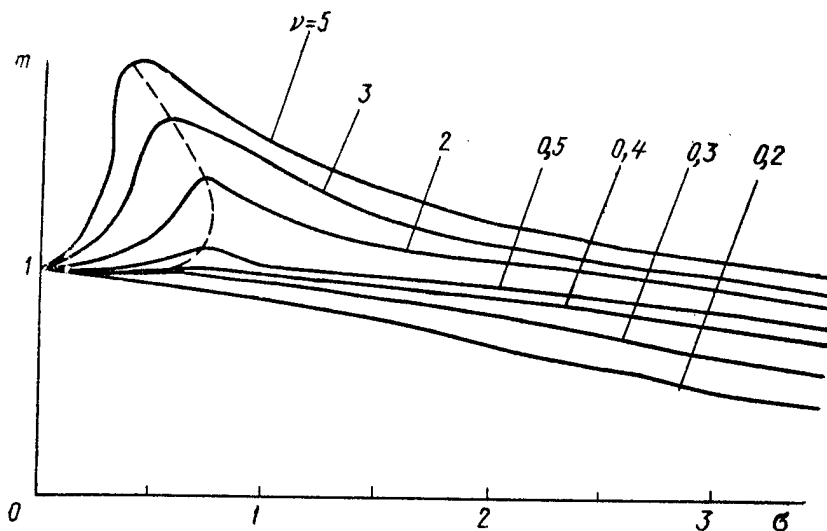

The maximum permissible cutoff frequency of the digital follow-up system (at given delay τ) can be increased with an increase of quantification time T_0 by a small value δ in a digital follow-up system in some practical situations.

1. If the dynamics of the control object $W_0(p)$ is characterized by a "small" time constant ($\nu \gg 1$) (considerably less than the delay in the system), the bandwidth of the digital follow-up system can be increased due to the fact that the proportionality constant (9) will have an extreme value with respect to parameter σ . The lower the inertia of the control object ($T_1 \ll \tau$), the less the value δ should be.

2. If the inertia of the control object is large ($T_1 \gg \tau$), an increase of the quantification time T_0 by value δ ($T_0 = \tau + \delta$) does not result in an increase of the cutoff frequency of the digital follow-up system.

The relations found in the article permit one to design digital control algorithms for follow-up systems (with known delay in them) and to determine the optimal quantification time T_0 , at which the maximum transmission frequency of the digital follow-up systems is provided.

BIBLIOGRAPHY

1. Slyusar, V. M., V. V. Tsisarzh, and I. A. Budnik, "Intercycle Error of Digital Follow-Up System," MEKHANIKA GIROSKOPICHESKIKH SYSTEM, No 7, 1988.
2. Yushchenko, V. A., "Teoriya diskretnykh sistem avtomaticheskogo upravleniya" [Theory of Digital Automatic Control Systems], Moscow, 1983.

{sb}Abstracts From Journal MEKHANIKA GIROSKOPICHESKIKH SYSTEM

907F0290AA Kiev MEKHANIKA GIROSKOPICHESKIKH SISTEM in Russian, Issue 8, 1989 pp 115-120

{sb}[Abstracts of articles appearing in "Mechanics of Gyroscopic Systems," Issue 8, 1989]

{txt}[Text]

{ud}UDC 629.12.053.11

On Dynamics of One-Rotor Gyrocompass With Tuned Rotor Gyroscope. V. V. Avrutov, M. A. Pavlovskiy, and L. M. Ryzhkov, p 3

The dynamics is studied and the accuracy of a one-rotor correctable gyrocompass, based on a two-axis indicating stabilized platform and two-race tuned rotor gyroscope (DNG), is analyzed. Separation of the complete model of the device into compass and vibration permitted us to determine the characteristic features of the dynamics of a gyrocompass with DNG. Analysis of the compass motion showed the dependence of the instrument error on the drift, time constant and residual stiffness of the DNG, and also on the static errors of the follow-up systems. The two-axis suspension of the platform led to differences of the expressions of intercardinal deviations of the studied device and of a one-rotor gyrocompass with rigid torsion bar suspension. 1 Figure, 4 references.

{ud}UDC 531.383

Selection of Geometric Dimensions of Flexible Elements of Gimbal Suspension of Tuned Rotor Gyroscopes. I. V. Balabanov and A. N. Motornyy, p 10

A method of selecting the geometric dimensions of the flexible elements of a tuned rotor gyroscope upon fulfillment of impact and cyclic strength conditions and stiffness requirements on the flexible elements is presented. The comparative characteristic of the DNG with flexible elements of variable and constant cross-section is given. 3 References.

{ud}UDC 531.383

Study of Dynamics of Two-Degree Gyrotachometer With Rotating Gimbal Suspension. V. S. Yevgenyev, A. V. Yeroshenko, and S. G. Bublik, p 14

The dynamics of a two-degree gyrotachometer with induced rotation, mounted on a uniformly rotating base, with different relations of angular velocities, is studied. It is shown that this device has the properties of a one-race rotary vibratory gyroscope (RVG). The conditions of dynamic tuning of the gyrotachometer are found and its advantage is compared to the RVG are indicated. 2 Figures, 4 references.

{ud}UDC 531.383

Dynamic Effects in Gyroscope Mounted on Flexible Suspension Upon Acceleration of Its Rotor. A. V. Zbrutskiy, L. Yu. Akinfiyeva, S. Ya. Svistunov, and I. B. Kushnirenko, p 17

The motion of a gyroscope with flexible suspension on a rotating base during acceleration of its rotor is considered. Separation of complex motion into "fast" and "slow" with subsequent use of the averaging operation is suggested to study the dynamics of the gyroscope. A solution of a system of differential equations of motion of a rotor on a flexible suspension, which describes the motion of the rotor over the entire range from acceleration to reaching the established mode, is constructed. 1 Figure, 8 references.

{ud}UDC 531.383

Errors of Angular-Rate Sensor on Tuned Rotor Gyroscope. A. V. Zbrutskiy and S. A. Shakhov, p 24

A mathematical model of the errors of an angular-rate sensor on a tuned rotor gyroscope with two-race symmetrical flexible suspension is found. The effect of errors in manufacture and errors of the feedback circuit on the accuracy of the readings of the instrument. 4 References.

{ud}UDC 531.768

Error of Pendulous Compensation Accelerometer With Flexible Suspension During Operation Under Spatial Vibration Conditions. A. M. Ionin and V. M. Slyusar, p 29

The mechanics of the occurrence of the constant component of the error a pendulous compensation accelerometer (MKA) with flexible suspension, exposed to spatial vibration conditions, is studied. Expressions are found that permit numerical estimation of the constant error component of the MKA. The requirements on the parameters of one of the accelerometer circuits, fulfillment of which permits one to make the MKA

invariant to spatial vibrations, are formulated. 2 Figures, 1 reference.

{ud}UDC 532.516

On Calculation of Temperature Field in Floated Suspension. A. S. Kireyev and A. N. Mikhaylovskaya, p 34

Finite element postulation of the problem of determining a three-dimensional temperature field is presented. A calculating algorithm is described and the results of calculation of several eigen forms of temperature distribution in the cylindrical region are presented. 1 Figure, 5 references.

{ud}UDC 531.313:532.58

Study of Rotation of Solid in Floated Suspension. A. S. Kireyev, Yu. V. Radysh, and A. I. Yurokin, p 38

The kinematic model of rotation of a solid in non-canonical geometry in a floated suspension, which takes into account the nonlinear nature of the equations of motion of a viscous liquid, is worked out. The characteristic features of integration of the derived equations are considered. The results of numerical calculations are presented. 3 Figures, 7 references.

{ud}UDC 621.391

Using Redundant Information to Estimate Errors of Measuring Angular-Rate Converters. A. A. Leonets, p 44

Expressions are found that permit one to estimate the multiplicative and additive components of the errors of measuring angular-rate converters during functioning of the measuring system, consisting of two measuring converter modules of the same type, mounted on a rigid object. 2 References.

{ud}UDC 621.391:531.383

Bayes Approach to Problems of Estimating Condition of Rotor Systems. V. Ye. Petrenko and A. N. Belyakov, p 47

The distribution density of the signal probabilities was found in parametric form on the basis of nonlinear dependence of the diagnostic signal on defects of the ball-bearing seat of a rotor system. The problem of approximating this density is solved. Estimation of the unknown parameter of signal density is found by the given sample. Approximations for conditional densities of class of suitable and unsuitable products are constructed. The threshold of separation of classes is found as a result of using the Bayes criterion and the probabilities of errors of first kind, of second kind and the average

risk in making the decision are calculated. The proposed approach can be used to solve problems of nondestructive diagnostics of symmetrical rotor systems. 7 References.

{ud}UDC 531.383

Dynamics of Surveying Gyrocompass. V. Ye. Petrenko, S. A. Zakharenko, and A. Ye. Ponomarenko, p 52

Approximate analytical functions that permit one to calculate the natural frequencies of a surveying gyrocompass during parametric perturbation due to imperfection of the ball bearings are found. 2 Figures, 2 references.

{ud}UDC 539.30/32

On Parametric Vibrations of Vibration-Isolated Pendulum. L. M. Ryzhkov, p 57

The vibrations of a pendulum, vibration-insulated in the horizontal plane, during vertical vibration of the base are considered. It is shown that unstable vibrations may occur upon excitation at frequencies which exceed the resonance frequencies of the system. Expressions are found that permit one to select the damping coefficients in the pendulum and in the vibration-protection system, which guarantee stability of fluctuations. 1 Figure, 2 references.

{ud}UDC 531.383

Gyroscopic Effect in Surface Acoustic Waves. S. A. Sarapulov and S. P. Kisilenko, p 62

The effect of uniform rotation of a base on the evolution of surface acoustic waves was studied. The functions that link the variation of frequency and phase of the autogenerators and delay lines or filters on surface acoustic waves to angular velocity are established. 5 References.

{ud}UDC 513.36:681.3.06

Computer Study of Drift of Cushioned Gyroscope During Angular Vibration of Base. S. Ya. Svistunov and Ye. V. Semikina, p 65

The results of using the MIT-1 applications program package in study of the dynamics of gyroscopes with regard to a vibration-insulation system are presented. The behavior of a three-degree cushioned gyroscope during angular vibration of the base, the drift of the gyroscope in resonance modes, on shock absorbers and with rigid mounting on the object are analyzed. The results of analytical studies and the results of operation of the package are compared. 1 Table, 2 figures, 6 references.

{ud}UDC 531.383

On Azimuth Motion of Pendulous Gyrocompass in Exponential Acceleration of Its Rotor. V. N. Fedorov, p 70

The motion of the sensitive element of a ground-based pendulous gyrocompass in the horizontal plane during exponential acceleration of its rotor is considered. The law of azimuth motion of the sensitive element is found as a solution of the hypergeometric Gauss equation at non-zero initial conditions. 1 Figure, 6 references.

{ud}UDC 517.9+518.6

Design of Discrete Model of Motion of Solid in Flexible Suspension. A. S. Apostolyuk and V. N. Sheludko, p 74

A procedure for designing a digital model of motion of a solid on a flexible suspension, based on the use of the discrete analogue of differential Lagrange equations of second kind, is proposed. The model permits one to take into account the nonlinear nature of vibrations and can be used in real-time simulation of vibration-protection systems. 1 Figure, 6 references.

{ud}UDC 007.62

Algorithm for Real-Time Calculation of Reduced Moments of Inertia of Multilink Manipulation Systems. S. G. Bublik and V. S. Yevgenyev, p 80

A method of computer calculation of the reduced moments of inertia of the links of anthropomorphic-manipulators using the design of a system of four material points, equal moment to arbitrary solids, is outlined. Realization of the algorithm on a microcomputer showed its effectiveness and the possibility of use in control systems of complex multilink manipulation systems. 3 references.

{ud}UDC 628.517

Nonlinear Effects in Vibration-Protection Systems With Stiffness Correctors. B. I. Genkin, N. I. Nagulin, and A. G. Arkhipov, p 83

Nonlinear vibrations of systems with stiffness correctors are studied. The possibility of vibrations with large amplitudes occurring in these systems in the working frequency band is shown. Ways of correcting these vibrations are discussed. 2 Figures, 3 references.

{ud}UDC 517.946.9

Mathematical Problems of Dynamics of Viscous Liquid in Gyroscopy. G. A. Legeyda, p 87

Problems of single-valued solvability as a whole and of the asymptotic stability of the three-dimensional problem of thermoconvection in the presence of axial symmetry are studied. Estimates for generalized solution of $\{\psi, \theta\}$ in the corresponding norms are found. The essence of the numerical analytical method of solution, based on finite difference quantification of the equations over time t and the use of the Galerkin method with finite element Hermitian basis with respect to spatial variables is outlined briefly. 4 References.

{ud}UDC 62.502

Design of Optimal Follow-Up System With Combination Control. V. V. Lyakin and V. V. Tsisarzh, p 92

The problem of designing the transfer functions of elements of a follow-up system with combination control according to the master signal in the presence of random noise is solved. A formula is found for calculation of the variance of the error of the system to be designed. An example of designing a combination follow-up system is presented. 1 Figure, 3 references.

{ud}UDC 681.51

Design of Regulator According to Given Characteristic Polynomial for Objects With Continuous Perturbations. Yu. V. Morozov, p 96

Algebraic design of a regulator using the canonical form of representing the initial system of linear differential equations that describes the motion of the control object with regard to continuous perturbations is presented. The synthesized design has the property of isodromy. 1 Figure, 2 references.

{ud}UDC 629.7.05(075.8)

Algorithm for Formulation of Orientation Vector of Moving Object, Invariant to Constant Error of A Priori Data. M. A. Pavlovskiy, G. Ye. Anupriyenko, and A. N. Klimenko, p 99

It is shown that the known second-order estimator for the control system of orientation of a solid, making small revolutions of the object with respect to the principal axes of inertia (the plane problem), forms current values of the phase vector with constant error at constant error of a priori data on the mass-size characteristics of the object and of the modulus of the moment applied to the body of the object. A method of synthesizing the algorithm for a third-order estimator, free of the indicated deficiency, is presented. 2 References.

{ud}UDC 581.383

General Solution of Problem of Theory of Elasticity of Rotating Medium. S. A. Sarapulov, p 103

The possibility of generalizing the Lamé theorem for the problem of the theory of the elasticity of a rotating medium is shown. Special cases of rotation about a fixed axis, the plane problem of elasticity theory, and vibrations of a thin ring are considered. 5 References.

{ud}UDC 531.01:513.83

Manifold Properties of One Class of Non-Autonomous Systems. N. S. Sivov and M. K. Sparavalo, p 107

A new class of non-autonomous systems, which have special properties in a certain range, which are called manifold properties, is considered. The existence theorem of systems of this class is proved. The concept of the independence of a finite set of the system, characterized by a Jordan measure, with respect to some initial concept, is formulated. This concept is called μ -invariance. 3 Tables, 3 references.

{ud}UDC 531.768

Optimization of Quantification Period in Digital Follow-Up System With Given Delay. V. M. Slyusar, V. V. Tsisarzh, and V. M. Rechkin, p 112

The effect of delay in a digital follow-up system on the maximum bandwidth is considered. Relations are found that permit one to determine at given delay the optimal value of the quantification period in a system, at which the maximum cutoff frequency of the digital control system is provided. 1 Figure, 2 references.

- END -

22161

37

NTIS

ATTN: PROCESS 103
5285 PORT ROYAL RD
SPRINGFIELD, VA

22161

This is a U.S. Government public policy, view, or attitude of the U.S. Government. Users of this publication may cite FBIS or JPRS provided they do so in a manner clearly identifying them as the secondary source.

Foreign Broadcast Information Service (FBIS) and Joint Publications Research Service (JPRS) publications contain political, military, economic, environmental, and sociological news, commentary, and other information, as well as scientific and technical data and reports. All information has been obtained from foreign radio and television broadcasts, news agency transmissions, newspapers, books, and periodicals. Items generally are processed from the first or best available sources. It should not be inferred that they have been disseminated only in the medium, in the language, or to the area indicated. Items from foreign language sources are translated; those from English-language sources are transcribed. Except for excluding certain diacritics, FBIS renders personal names and place-names in accordance with the romanization systems approved for U.S. Government publications by the U.S. Board of Geographic Names.

Headlines, editorial reports, and material enclosed in brackets [] are supplied by FBIS/JPRS. Processing indicators such as [Text] or [Excerpts] in the first line of each item indicate how the information was processed from the original. Unfamiliar names rendered phonetically are enclosed in parentheses. Words or names preceded by a question mark and enclosed in parentheses were not clear from the original source but have been supplied as appropriate to the context. Other unattributed parenthetical notes within the body of an item originate with the source. Times within items are as given by the source. Passages in boldface or italics are as published.

SUBSCRIPTION/PROCUREMENT INFORMATION

The FBIS DAILY REPORT contains current news and information and is published Monday through Friday in eight volumes: China, East Europe, Soviet Union, East Asia, Near East & South Asia, Sub-Saharan Africa, Latin America, and West Europe. Supplements to the DAILY REPORTs may also be available periodically and will be distributed to regular DAILY REPORT subscribers. JPRS publications, which include approximately 50 regional, worldwide, and topical reports, generally contain less time-sensitive information and are published periodically.

Current DAILY REPORTs and JPRS publications are listed in *Government Reports Announcements* issued semimonthly by the National Technical Information Service (NTIS), 5285 Port Royal Road, Springfield, Virginia 22161 and the *Monthly Catalog of U.S. Government Publications* issued by the Superintendent of Documents, U.S. Government Printing Office, Washington, D.C. 20402.

The public may subscribe to either hardcover or microfiche versions of the DAILY REPORTs and JPRS publications through NTIS at the above address or by calling (703) 487-4630. Subscription rates will be

provided by NTIS upon request. Subscriptions are available outside the United States from NTIS or appointed foreign dealers. New subscribers should expect a 30-day delay in receipt of the first issue.

U.S. Government offices may obtain subscriptions to the DAILY REPORTs or JPRS publications (hardcover or microfiche) at no charge through their sponsoring organizations. For additional information or assistance, call FBIS, (202) 338-6735, or write to P.O. Box 2604, Washington, D.C. 20013. Department of Defense consumers are required to submit requests through appropriate command validation channels to DIA, RTS-2C, Washington, D.C. 20301. (Telephone: (202) 373-3771, Autovon: 243-3771.)

Back issues or single copies of the DAILY REPORTs and JPRS publications are not available. Both the DAILY REPORTs and the JPRS publications are on file for public reference at the Library of Congress and at many Federal Depository Libraries. Reference copies may also be seen at many public and university libraries throughout the United States.