

JPRS-EST-90-022
31 OCTOBER 1990



**FOREIGN
BROADCAST
INFORMATION
SERVICE**

JPRS Report

DISTRIBUTION STATEMENT B
Approved for public release
Distribution Unlimited

Science & Technology

Europe
AEROTECH 89

19980123 080

DTIC QUALITY INSPECTED 3

REPRODUCED BY
U.S. DEPARTMENT OF COMMERCE
NATIONAL TECHNICAL INFORMATION SERVICE
SPRINGFIELD, VA. 22161

SCIENCE & TECHNOLOGY

EUROPE

AEROTECH 89

36980033 Birmingham AEROTECH-89 in English 31 Oct-3 Nov 89 in
Volumes 1-20,22-27

[Selections from the Aerotech-89 Aerospace Technology Exhibition
and Congress held in Birmingham, UK, 31 Oct-3 Nov 89, sponsored
by the Aerospace Division of the Institution of Mechanical
Engineers]

CONTENTS

Program.....	1
PLATO--A European Platform Orbiter Concept [Stephen Ransom, Dipl-Ing Rainer Hoffmann].....	9
HOTOL Space Transport for the 21st Century [B. R. A. Burns].....	19
Addressing the Challenge of Aircraft Component Design and Manufacture From Metal Matrix Composites [D. Charles].....	26
Superplastic Forming of Aluminium Alloys for Structural and Non-Structural Applications for the Aerospace Industry [B. J. Dunwoody, R. J. Stracey].....	42
Development of an SPF/DB Titanium Foreplane [S. H. Johnston].....	50

The Electric Aeroplane.....	1
The Electronic Cockpit [D. R. Tincello, Smiths Industries Aerospace and Defence Systems]	
Avionics architecture for application to future civil aircraft [A. J. Large, British Aerospace]	
Considerations of the all electric aircraft [R. I. Jones, Cranfield Institute of Technology]	
All electric technologies in future advanced aircraft [M. J. J. Cronin, Lockheed Aeronautical Systems, U.S.A.]	
Structural Analysis Methods.....	2
Advanced Application of IGES project [P. J. Smith, Technology Centre]	
Validating and updating finite element models using experimental measurements of dynamics [C. F. McCulloch, Dynamic Engineering; UK, P. Vanhonacker and E. Dascotte, Dynamic Engineering, Belgium]	
An advanced boundary element package for solid mechanics [R. Gordon, R. A. Cookson, C. J. Coomber and A. M. El-Zafrany, Cranfield Institute of Technology]	
Adaptive control of High Powered Missile Launchers using a Microprocessor based Servo-Hydraulic System [R. R. Bickle and J. W. Henn, British Aerospace]	
Aerospace Manufacturing Technologies.....	3
Manufacturing technology in aerospace: the real challenge [J. Kirton, Ingersoll Engineers Ltd.]	
The production of aircraft structures using resin transfer moulding with Courtaulds knitted preform technology [J. Sharkey, Courtaulds Structural Composites]	
Titanium castings--today and tomorrow [R. H. Cooley, Ti-Tech International Inc.]	
Advanced manufacturing cells at British Aerospace Warton unit [J. M. Duxbury, British Aerospace Military Aircraft Ltd.]	

Airborne Sensors and Systems.....	4
Reconnaissance Sensor Management System--Vicon 2000 [R. G. Harris and D. Langley, Vinten Military Systems Ltd.]	
Condition Monitoring of Aircraft Mechanical Systems [K. W. Chan and G. Southcombe, British Aerospace; G. J. Trmal and A. P. H. May, Bristol Polytechnic]	
Fuel quantity measurement on commercial aircraft [E. Ruff, BAe (Commercial Aircraft) Ltd.]	
Ballistic Tolerances of flying control units [A. Lewis, Dowty Boulton Paul Ltd.]	
Avionics Cooling (I).....	5
Definition of problems, fundamental heat transfer and analysis techniques [H. E. George, R. F. Babus'Haq, P. W. O'Callaghan, S. D. Probert, Cranfield Institute of Technology]	
Equipment cooling systems--the operator's experience [B. D. Gibbs, British Airways]	
Avionics cooling in helicopters [J. Bayes, Westland Helicopters Ltd.]	
New Manufacturing Techniques in Aerospace.....	6
Short carbon fibre reinforced thermoplastics for component cost reduction and improved performance [A. P. Cluley, Product Manager, Courtaulds Grafil Ltd.]	
Integrated parametric CAD/CAM method applied to design, construction and manufacture of aircraft structural components [J. Saggi and J. P. Fielding, Cranfield Institute of Technology]	
Development of Filament Winding [V. Middleton and M. J. Owen, The University of Nottingham]	
"Revolutionary" Rotors [J. Spooncer, Westland Helicopters Ltd.]	
The manufacture and development of advanced wing technology [D. Wolstencroft, British Aerospace (Military Aircraft) Ltd.]	

Aircraft Safety in the 1990's.....	7
Composite materials--fire resistance and breakdown emissions [K. W. Smith, RAF College, Cranwell]	
Pulse Equipment [I. A. Levin, Impulse Apparatus, Moscow]	
Towards the Paperless Aircraft [K. P. O'Kane, British Aerospace (Military Aircraft) Ltd.]	
Exploitation and Exploration of Space.....	8
PLATO--A European Platform Orbiter Concept [Stephen Ransom and Dipl-Ing Rainer Hoffmann, MBB-ERNO Raumfahrttechnik, FRG]	
EUROSTAR--The Evolution of a Multipurpose Satellite [M. S. Kendrew, British Aerospace (Space Systems) Ltd.]	
An assessment of the risk areas in the development of on-board software for space applications [M. Irving and J. Lee, Logica Space and Defence Systems Ltd.]	
The Man Machine Interaction for Telescience Operations [Claire Pinches, Commercial Space Technologies Ltd.]	
Spacecraft Exploration of Comets: The Past and Future [M. Noton, British Aerospace (Space Systems)]	
Aero Engine Systems Into the 1990's.....	9
Technological trends in engine test facilities [G. F. Dawson, Industrial Acoustics Company Ltd.]	
A review of elevated temperature measurements in gas turbine exhausts [K. H. Maden, Aero and Industrial Technology Ltd.]	
The repair of aircraft integral fuel tanks in the R.A.F.--a user's view of fuel tank technology [G. S. Dawson, Royal Air Force]	
Avionics Cooling (II).....	10
The Tiald pod avionics cooling system [P. Curson, Ferranti Defence Systems Ltd.]	

Fan technology	
[D. C. Moore, AK Fans Ltd.]	
Air cycle cooling systems	
[B. Rogers, Normalair-Garrett Ltd.]	
New and Advanced Manufacturing Processes.....	11
An integrated approach to program, analysis and simulation of filament wound composites	
[R. R. Roser and M. L. Skinner, Engineering Technology Inc, USA]	
Future fastening systems for aerospace structures	
[T. A. Roach, SPS Technologies, USA]	
Technology of product finishing utilizing the Vapormatt process	
[S. I. Ashworth, Vapormatt Ltd.]	
Computer monitored shot-peening for design assurance	
[P. O'Hara, Metal Improvement Co.]	
Safety and Reliability in Aerospace.....	12
Flight crew fatigue and its control	
[R. A. Lister, Civil Aviation Authority]	
Cabin safety research at Cranfield	
[H. C. Muir, C. Marrison and P. J. Fennell, Cranfield Institute of Techn.]	
Mechanical damage to aircraft structures from lightning strikes	
[G. W. Reid, UKAEA Technology]	
European Collaboration on Safety	
[G. le Houx, JAA Secretariat]	
Space Launch Vehicles.....	13
Why space is expensive--Operational/economic aspects of space transport	
[R. C. Parkinson, Aerospace (Space Systems) Ltd.]	
HOTOL space transport for the 21st Century	
[B. R. A. Burns, British Aerospace (Military Aircraft) Ltd.]	

Advanced Aircraft Systems.....14

New control techniques for Aerospace Applications
[M. J. Grimble, Industrial Systems & Control Ltd.,
D. J. Diston and N. A. Fairbairn, University of
Strathclyde and K. P. Holmes, Industrial Systems Control
Ltd.]

A computer-aided design environment for flight control
system design
[S. J. Williams, Cambridge Control Ltd.]

New Developments in Direct Speech Input Control Systems
[I. Galletti and M. G. Abbott, Marconi Speech
and Information Systems]

Improved performance through multivariable analysis and
control design
[S. J. Williams, Cambridge Control Ltd.]

Advanced Propulsion Systems (I).....15

Current and future aero engine developments
[P. C. Ruffles, Rolls-Royce]

The impact of bypass ratio on the performance of future
civil aero engines
[M. S. Ivey, RAE Pyestock]

Aero engine design factors for a low fuel price scenario
[S. J. Hartropp, Rolls Royce]

Basic safety principles in nacelle and engine installation
design
[B. Wrigley, Rolls-Royce]

New Developments in Aerospace Materials (II).....16

Titanium usage in helicopter rotor heads
[D. P. Davies, Westland Helicopters Ltd.]

Particle reinforced metal matrix composites
[A. R. Begg, BP Metal Composites Ltd.]

Addressing the challenge of aircraft component design
and manufacture from metal matrix composites
[D. Charles, British Aerospace (Commercial Aircraft)
Ltd.]

Software Maintenance and Reliability.....17

Aircraft Software support in the Fleet Air Arm
[A. D. McBeath, Directorate General Aircraft (Navy)]

Avionic software support in the Royal Air Force
[K. Trotter, Ministry of Defence (Air Force
Department)]

Software maintenance for safety critical systems
[R. Pilsworth, Aquilla UK Ltd.]

Software maintenance in commercial aircraft
[C. R. Davies, British Aerospace (Commercial Aircraft)
Ltd.]

Ground Support Equipment.....18

The environment and ground support equipment
[R. F. Mackrill, British Aerospace (Military Aircraft)
Ltd.]

Development of HST MK 16 MoD
[M. Freer, HML (Engineering) Ltd.]

GSE data capture and analysis
[R. E. Sowden, RAF]

Differences between military GSE and Civil GSE
[J. S. Smith, Manchester Airport]

Advanced Aircraft Systems (II).....19

EH101 System Architecture
[K. G. Bannister, Westland Helicopters Ltd.]

Adaptive control of high power missile launchers using
a microprocessor based servo-hydraulic system
[J. W. Henn and R. R. Bickle, British Aerospace]

Auxiliary Power
[E. H. Warne]

Constant speed drive for aircraft generating system--a
gear differential for high speeds
[C. R. Schofield, Lucas Aerospace Ltd.]

Advanced Propulsion Systems II.....	20
Aero engine and component management--leaving well alone [R. H. W. Brook, R and R Brook]	
Military engine technology--EJ200 [S. P. Q. Byworth, Rolls Royce]	
Performance prospects for future helicopter engines [M. G. Philpot and A. D. Bewley, Royal Aerospace Establishment]	
Integrated Logistics.....	22
ILS for EFA [I. Brackenbury, Ministry of Defence]	
Applied supportability techniques of Rolls-Royce military engine group [T. Roach, Rolls-Royce]	
Adopting ILS as a Corporate Strategy for Profit [R. A. Butler, Systems Exchange Inc, USA]	
Surface Treatment Technologies.....	23
Shot and bead peening control [R. John, TEALGATE Ltd.]	
Simultaneous spray peening techniques in the development of new materials [J. V. Wright, Aero and Industrial Technology Ltd.]	
Long life topcoat--new generation aerospace coatings based on advanced fluropolymer technology for civil and military use [B. R. Parrott, De Solo Titanine]	
Aircraft Data Management and Simulation.....	24
Thermal analysis and management of electronic equipment using computer techniques [D. R. Landeg and G. Monks, British Aerospace (Dynamics) Ltd.]	
Data preparation for computer aided process planning systems [R. F. Barlow, Dunlop Aviation Division]	
The static and dynamic analysis of aircraft simulators [J. M. O'Keeffe and N. R. Beagley, SDRC Engineering Services Ltd; T. Faithful, Singer Link Miles]	

Data Collection and Analysis of the Air Carriage Environment
of Guided Weapons
[R. A. E. Allen, British Aerospace (Dynamics) Ltd.]

Engine Testing and Instrumentation.....25

Dynamic tip clearance measurements in axial flow compressors
[C. H. Parrish, Rolls-Royce]

Laser anemometry in turbomachinery
[C. Forster, Cranfield Institute of Technology]

The design and commissioning of an acoustic liner for propeller
noise testing in the ARA transonic wind tunnel
[M. E. Wood, Aircraft Research Association Ltd.
and D. A. Newman, Rolls-Royce]

The specification and design of aero engine component test rigs
[R. G. Harman, Brown & Root Vickers Ltd.]

New Materials in Aerospace.....26

Addressing the challenge of aircraft component design and
manufacture from metal matrix composites
[D. Charles, British Aerospace (Commercial Aircraft)
Ltd.]

Superplastic forming of aluminium alloys for structural and
non-structural applications for the aerospace industry
[B. J. Dunwoody and R. J. Stracey, Superform
Metals Ltd.]

Development of an SPF/DB Titanium Foreplane
[S. H. Johnston, British Aerospace (Military Aircraft)
Ltd.]

Maintenance of Mature Aircraft.....27

Maintenance of Concorde into the 21st Century
[M. J. Phillips, British Airways]

Maintaining mature military aircraft
[G. Skinner and R. W. Hooper, Command, Royal Air
Force]

Non-destructive evaluation for mature aircraft
[D. A. Bruce, Royal Aerospace Establishment]

Improving the cost-effectiveness of air-frame inspection--a
systems approach
[R. Smith, Harwell Laboratory, AEA Technology]

PLATO — A European Platform Orbiter Concept

by Stephen Ransom, BSc(Eng), CEng, MRAeS, MIMechE and
Dipl-Ing Rainer Hoffmann,
Orbital Systems and Launcher Division, MBB-ERNO Raumfahrttechnik,
Bremen, Federal Republic of Germany.

SYNOPSIS. PLATO is a small, unmanned, winged re-entry vehicle designed for launch by Ariane and retrieval by conventional landing at a site in Europe. The vehicle is intended for conducting material and life science experiments in space and for developing materials, structures and navigation and control techniques for future spacecraft. The concept is proposed with the aim of providing European autonomy in the operation of retrievable spacecraft. Simplicity in the realization of the concept and the minimization of costs are key factors in the development of PLATO.

NOTATION

A	Aspect ratio
C_D	Drag coefficient
C_L	Lift coefficient
$C_{L\alpha}$	Lift curve slope
C_l	Rolling moment coefficient
C_m	Pitching moment coefficient
C_n	Yawing moment coefficient
$C_{l\beta}$	Rolling stability derivative
$C_{n\beta}$	Yawing stability derivative
ΔC_{L_c}	Lift increment due to control deflection
ΔC_{l_c}	Rolling moment due to control deflection
ΔC_{m_c}	Pitching moment due to control deflection
ΔC_{n_c}	Yawing moment due to control deflection
Ma	Mach number
Re	Reynolds number
α	Angle of incidence
β	Angle of yaw
δ	Control surface deflection
Λ	Wing sweep
λ	Wing taper ratio

Subscripts:

A	Aileron
F	Trailing-edge flap
R	Rudder

1 INTRODUCTION

The uncertainty surrounding the resumption of NASA Shuttle operations after the accident in January 1986 and the possibility that when they resumed certain payloads would be given priority, together with the lack of an adequate European launch and retrieval vehicle for ESA's European Retrievable Carrier (EURECA, Fig 1), gave grounds for thinking that the opportunities for EURECA-type missions would be reduced and, in the extreme case, cease. The desire to decouple EURECA operations from dependence on US space transport led to studies of methods of launching EURECA by Ariane (1, 2) and servicing the spacecraft in orbit by Hermes (3). Retrieval of EURECA was, nevertheless, still dependent on the Shuttle

since, although Hermes at the time of these studies had a cargo bay, Hermes was not capable of retrieving EURECA. The questions which remained, therefore, were: how could EURECA be retrieved without resorting to the use of the Shuttle, or how could EURECA be developed as a completely autonomous European system?

The answer to both questions led to the idea of integrating EURECA in a winged re-entry vehicle, it being launched by Ariane 4 from Kourou and retrieved as a glider to a base in Europe. The mission was to be fully automatic and EURECA was to remain an integral part of the complete spacecraft. Further, the nature of a EURECA mission, that is, one employing fully autonomous payload operations, suggested that, perhaps, it was feasible to use also some of EURECA's systems for the control of the return flight. It was envisaged here that the use of EURECA's power, attitude and orbit control, communications and data handling systems could be used, they being switched over to the return flight mode at the end of the payload in-orbit operation mode of the vehicle.

The proposal to use Ariane 4, however, resulted in the EURECA component of the re-entry vehicle being scaled down to approximately half its present size in order to match the complete spacecraft's mass with the launcher's payload capacity. This was done by revising the layout of the platform's primary structure and deleting one of its solar arrays. The single-piece wing was fitted to the underside of EURECA, from which the trunnion and keel attachment fittings required for Shuttle operations had been removed. At the same time, the systems located on its lower surface were relocated to facilitate the installation of the wing and improve their accessibility. The modified EURECA was enclosed in a fairing fitted with doors which allowed the deployment and retraction of the solar array in the in-orbit operational mode. In the launch phase the spacecraft was arranged to be mounted co-axially to Ariane via the latter's Vehicle Equipment Bay (VEB) adapter.

The spacecraft was required to land conventionally on a surfaced runway. In order to minimize structural problems with the design of the

ng arising from the installation of the undercarriage, it was considered feasible to install the main undercarriage in vertical tails located at the wing's tips and the nose undercarriage in the forward part of the fairing covering EURECA. With this arrangement the vehicle was required to roll through 180 degrees prior to landing, the undercarriage being located on the upper side of the spacecraft during re-entry and the hypersonic flight phases. This arrangement brought with it the advantages that the heat shield covering the lower surface of the wing was not interrupted by the presence of undercarriage doors, that problems associated with the thermal sealing of the doors were removed, and that the wing structure and main undercarriage installation were simplified. It was anticipated that the roll manoeuvre could be controlled using known flight control techniques.

At this stage of its evolution the spacecraft resembled the Hermes configuration but had larger vertical tails at its wing tips (Fig 2). The flight control surfaces comprised wing trailing-edge flaps, which combined the functions of flaps, elevators and ailerons, and rudders fitted to the wing-tip surfaces. This preliminary configuration was named PLATO, an acronym derived from Platform Orbiter. The overall operational scenario is shown on Fig 3.

2 PLATO DEVELOPMENT

The further development of PLATO was undertaken with the following objects in mind:

- (a) to keep all costs associated with a potential PLATO programme to a minimum,
- (b) to minimize the application of advanced technologies and, wherever possible, to use existing techniques, materials and components available within a development and manufacturing schedule based on a first operational mission in the period 1995-2000, and
- (c) to make full use of experience gained during the preparation of EURECA's first mission and other programmes in regard to ground and flight operations.

The first step in the development process was a critical appraisal of the proposed PLATO configuration. The main points addressed were: aerodynamic characteristics and the size and internal arrangement of PLATO.

2.1 Mission performance

The basic requirement for PLATO to be launched from Kourou by Ariane and retrieved from orbit to make a conventional landing at a base in Europe demands:

- (a) that the mass of the vehicle is within the launch capability of Ariane 4. However, certain restrictions apply to payloads launched by Ariane 4 into low Earth orbits, namely, that the induced loads at the interface between the launcher's third stage (H10) and the VEB do not exceed specific values. This restriction implies that the full capacity of Ariane 4 cannot be used and, consequently, the total mass of PLATO at lift-off has to be limited to a maximum of about 5000 kg.

The results of a computer simulation to optimize the ascent trajectory to stay within Ariane 4 launch limitations are given in Section 3.1.

- (b) that PLATO is aerodynamically efficient to achieve a cross-range of at least 2000 km for a landing in Europe, as is the case if PLATO is launched into a 28.5 degree/500 km circular orbit. (This orbit was selected to allow comparisons with Shuttle and Hermes performance data. In principle, there is no restriction on the inclination of the orbit into which PLATO can be injected). In order to meet the cross-range requirement, PLATO must have a high trimmed lift/drag ratio at hypersonic speeds (typically of the order of 1.5 - 1.7).
- (c) that PLATO's landing speed is low (less than 100 knots) if the mechanical complexity associated with conventional methods of braking the vehicle to a standstill on landing is to be reduced. This requirement can be met by selecting a low wing loading.

The return flight phase of PLATO also requires that the spacecraft is fully controllable over the entire speed range of approximately Mach 25 to Mach 0.15. The envisaged methods of control in the various flight regimes are:

re-entry:	spacecraft's thrusters
hypersonic:	thrusters and elevator
super-/subsonic:	flight control surfaces

Ideally the control surfaces should have linear aerodynamic characteristics with no tendency to reversal of their function with respect to PLATO's speed and angles of incidence and yaw. Also, the change of the wing's neutral point position with respect to speed should be gradual as the vehicle's speed decreases.

The spacecraft should also possess good stability characteristics, although PLATO, as an unmanned vehicle, does not have to respect this requirement since present control technology can be used to prevent manoeuvre departures and augment the vehicle's stability around all axes. It is considered desirable that PLATO is naturally stable at least about its yaw and roll axes. The experience gained with research aircraft in Europe and elsewhere allows consideration to be given to the design of a vehicle with a negative longitudinal static stability margin. This feature allows PLATO to be trimmed using positive (trailing-edge down) flap deflections while at the same time improving its lift and drag characteristics and trimmed lift/drag ratios.

2.2 Physical features

The critical appraisal of PLATO's configuration was undertaken in conjunction with an assessment of its performance. The assessment showed that, with vehicles the size of PLATO, the presence of the fuselage was a major contributor to the drag and, possibly, also to the roll and yaw instability of such spacecraft. A study of alternatives to the wing-fuselage configuration led to reconsideration of the lifting-body concept (4, 5) and, subsequently, to an investigation of the flying-wing. The latter revealed that the scaled-down EURECA could be accommodated within a wing with a thickness/chord ratio of about 12 per cent, provided that the wing had a very low

aspect ratio. At this juncture it was realized that empirical data, compiled during the course of private research by the first author, was of relevance. The data indicated that wings with an aspect ratio of about 0.6 might have similar longitudinal characteristics to those of an aspect ratio of about 1.2 (Fig 4). Moreover, it appeared that very low aspect ratio rectangular and delta wings might also have similar characteristics (Fig 5). Further, it was argued that if this indeed proved to be the case then manufacture of a rectangular wing should be simpler and, therefore, cheaper than a delta wing.

Re-entry heating effects demand that the wing has a large leading-edge radius so that temperatures and heating rates can be kept low. The use of conventional aerofoil sections (NACA type) for PLATO's wing, however, results in physically small leading-edge radii. The radius can be increased by employing a thicker aerofoil section but the wing is then larger than necessary for the accommodation of the modified EURECA. The search for a compromise eventually led to the tentative selection of a thick supercritical section for subsequent studies. A comparison of this type of section with that of the Shuttle to the same scale is shown on Fig 6.

The determination of the high angle of incidence characteristics of a very low aspect ratio wing with a supercritical aerofoil section not unnaturally posed certain difficulties since no basic information exists. Even data for thick-sectioned, very low aspect ratio wings were meager; only two potentially useful reports (6, 7) were found. The decision was made, therefore, to conduct at least low-speed wind tunnel tests of the PLATO configuration to obtain essential data.

Results from other re-entry studies indicated that problems due to thermal effects could occur with the synchronization of the rudders located at each wing tip. In addition, the integration of the rudders, main undercarriage and attitude control thrusters in the wing tip fins was considered too complicated. Simplification of the equipment installation and elimination of the potential rudder synchronization problem was achieved by combining the rudders and relocating them as a single all-moving fin close to the wing's apex. This re-arrangement brought with it the possibility of combining the nose undercarriage with the fin and removed the necessity for an extendible unit.

Further study of the undercarriage revealed the need for a European technology programme for the development of the wheels and, in particular, the tyres. There was also some doubt as to whether the wheels, together with their suspension and their extendible or jettisonable fairings, could be satisfactorily installed in the forward and wing-tip fins. The wheels, therefore, were exchanged for a sprung skid system in which the skids themselves formed the tips of the fins.

Figure 7 shows PLATO's configuration at this stage in its development and that on which the subsequent feasibility was based.

3 RESULTS FROM FEASIBILITY STUDY

The first phase of a feasibility study of the

PLATO concept has been conducted for the German Ministry of Research and Technology. It has concentrated on obtaining basic data relevant to the further development of the concept. In particular, computer simulations of ascent and re-entry profiles have been performed, preliminary thermal analyses have been made and a series of low-speed wind tunnel tests have been conducted. Analyses of the supersonic and hypersonic aerodynamic characteristics of the spacecraft were based on available data, wind tunnel tests at these speeds being planned for later phases of the study.

3.1 Ascent phase

The ascent profile for the PLATO/Ariane 4 combination was determined by reiterative computer simulation techniques, which took into account the wind profile at the Kourou launch site. Optimization of the ascent trajectory was undertaken with the objects of determining:

- (a) the maximum mass of PLATO which could be directly injected into a 28.5 degree/500 km circular orbit by Ariane 4 whilst respecting VEB/H10 interface load constraints,
- (b) the required Ariane 4 booster configuration, and
- (c) the trajectories of the spent Ariane booster and rocket stages.

The results of the simulation showed that it was feasible to launch PLATO by Ariane 44P (four solid propellant boosters), the spent boosters and first and second stages falling back into the Atlantic. Injection of PLATO directly into a circular orbit, however, results in the launcher's third stage remaining in orbit unless deboosted by retro-rockets. Alternatively, PLATO can be injected into an elliptical transfer orbit and manoeuvred into a circular orbit using its own propulsion system, in which case about 300 kg of mono-propellant is needed for orbit circularization. The third stage will then re-enter over the Pacific.

The maximum mass of PLATO's launch configuration was established at 5000 kg. The maximum induced loads at the critical VEB/H10 interface are reached 50 seconds after lift-off and at a speed of Mach 0.5. The magnitude of the critical loads is affected by the aerodynamic characteristics of PLATO and the angle of incidence of PLATO to the ascent flight path. Load limits are not exceeded if, during the subsonic and transonic flight phases, the angle of incidence is held below 2 degrees, an ascent profile different from that usually followed by Ariane 4.

The ascent trajectory optimization did not take into account bending moment relief effects generated by PLATO's mass at the tip of the launcher. Inclusion of this effect will allow PLATO's launch mass to be increased.

Other aspects to be considered in subsequent phases of the feasibility study include the launch of PLATO in a 'knife-edge' trajectory and bending moment relief by applying active control technology using the all-moving forward fin. These investigations are expected to lead to an increase in the maximum allowable PLATO launch mass.

3.2 Re-entry phase

The main purpose of the re-entry simulation was to determine PLATO's cross-range performance. The achievable cross-range strongly influences the choice of appropriate landing sites and operational procedures. An important parameter which determines cross-range capability is the vehicle's lift/drag ratio. During re-entry PLATO will fly a predetermined angle of incidence profile (Fig 8). At Mach numbers greater than 20, PLATO is flown at an incidence which generates high drag and minimizes the thermal loads on the wing and empennage leading-edges. The angle of incidence is gradually reduced after the spacecraft has flown through the maximum heating phase in order to increase the lift/drag ratio and maximize the cross-range. Bank angle modulation is used to guide the vehicle to the landing site. The spacecraft's cross-range capability is shown on Fig 9. The maximum is approximately 2000 km and is sufficient for the recovery of PLATO from a 28.5 degree orbit at landing sites located in southern Europe.

The aerodynamic coefficients required for the re-entry simulation were derived from available data (8). This information, although not strictly applicable, since it was obtained from supersonic wind tunnel measurements of sharp-edged, flat plate planforms, was considered adequate for initial estimates of PLATO's performance during re-entry. Moreover, the data were applicable to wings with an aspect ratio of 0.5 (c.f. aspect ratio of PLATO wing is 0.6) and the extrapolation of the pertinent coefficients, therefore, probably results in an underestimation of the lift/drag ratio (Fig 10). It is of interest to note that the alternative wing planforms considered here have almost identical characteristics at high angles of incidence.

The re-entry profile (Fig 11) was also used as the basis for a preliminary thermal analysis using Fortran programs developed by MBB/ERNO for determining the kinetic heating of aircraft and re-entry vehicles. Both PLATO variants were investigated: temperatures, heating rates and heat loads were calculated for specific regions of the wing with the assumption that all heat generated was completed radiated. The results of the analysis, therefore, are very pessimistic. The maximum temperatures at the surface of the wing are shown on Fig 12 and, as an example, the heating rates and loads at a point 3 m from the nose and on the underside of the vehicle are given on Fig 13. It should be noted that these values are much lower than the data obtained from Shuttle flights.

The results from the re-entry simulation indicate the effects of PLATO's low wing loading and high lift/drag ratio, namely:

- (a) relatively low heat fluxes can be expected because PLATO decelerates at high altitude. This situation results in low surface temperatures and allows PLATO to be manufactured from less exotic materials.
- (b) the total heat load is high because the flight time of approximately 40 minutes from the point of re-entry at an altitude of 120 km to when subsonic speed is reached is relatively long. Consequently, good insulation is required.

- (c) the maximum load factor is below 2g and, therefore, a benign environment is provided for PLATO's payload during re-entry.

3.3 Return flight phase

The aerodynamic characteristics of PLATO needed for performance estimates and for the design of the flight control system were obtained from analyses of wind tunnel measurements. Supersonic data (Mach 1.5 to Mach 4.6) were derived from References 8 and 9, and subsonic data from tests of 1/20-scale models performed in the low-speed wind tunnel of the Institut für Luft- und Raumfahrt, Rheinisch-Westfälische Technische Hochschule (RWTH), Aachen. The analyses concentrated on comparisons of the slender rectangular and delta wing planforms with the aim of selecting one of them for further study. It was not the intention at this stage of the study to obtain absolute data but the measurements made were considered sufficiently accurate to establish the order of magnitude of the aerodynamic derivatives and adequate for determining differences between the alternative PLATO configurations. The low speed analyses and measurements, together with descriptions of the models and test techniques, are reported in References 10 and 11.

Only the main results of the low speed analyses are presented here. Untrimmed coefficients are relative to a centre of gravity located at 50 per cent of the centre line chord; trimmed values are derived from an investigation of the effectiveness of the trailing-edge flaps in trimming the PLATO configuration. The optimal low-speed positions of the centre of gravity for the rectangular and delta wing configurations are 42.5 per cent and 47.5 per cent of the centre line chord respectively.

Comparisons between the trimmed and untrimmed longitudinal characteristics of the complete configurations are given on Fig 14. These show that the rectangular-winged version is superior. Data for angles of incidence greater than 30 - 35 degrees are of academic interest only since they are outside the incidence range in which PLATO will fly. The trimmed lift coefficient and lift/drag ratio at which PLATO will make its landing approach are 0.4 and 4.2 respectively. The corresponding angle of incidence is 19 degrees.

The untrimmed lateral characteristics of both PLATO configurations are shown on Fig 15. The data is given for the optimal low-speed centre of gravity locations. Both variants have naturally stable characteristics except in the landing configuration, where the rectangular-winged version has low yaw stability up to an incidence of about 20 degrees and the other variant is unstable in yaw. Both configurations are stable about the roll axis. Overall, the former variant has better characteristics than the latter. In view of the fact that the forward all-moving fin proved to be a very effective control device and contributed to reducing the configurations' yawing stability, future investigations will concentrate on examining the effects of reducing the area of the fin.

PLATO's trailing-edge flaps will be used as high-lift devices, for trimming and for pitch and

roll control. Flap angles needed to trim PLATO at low speed and the flaps' elevator control characteristics are given on Fig 16.

Roll control is provided by the outboard flaps. Aileron and elevator functions will be combined. The incremental rolling and yawing moments generated by an aileron deflection of -15 degrees (left aileron trailing-edge down; right aileron trailing-edge up) are given on Fig 17. The incremental rolling moments are approximately linear and of similar magnitude for both variants. The associated yawing moments are small. Of note is the undesirable yawing moment reversal in the usable incidence range of the delta-winged version.

Yaw control is provided by the all-moving, forward-located fin. The incremental yawing and rolling moments generated by this surface are given on Fig 18. In the case of the re-entry configuration they are large and those of the rectangular-winged variant exhibit a more linear characteristic. The magnitude of the moments is thought to be due to control deflection induced flow field disturbances triggering asymmetrical separation of the wing's vortices and they contributing to the rolling and yawing moments. The landing configurations' yawing and rolling moments generated by the fin are smaller and again exhibit approximately linear characteristics with no tendency to control function reversal in the usable incidence range. These results are considered to be good and to have sufficient margin to suggest that the fin can be reduced in area, or redesigned to have a more conventional form with a fixed surface and a trailing-edge flap. In the latter case, the redesign can lead to structural simplification and easier integration of the nose undercarriage.

The results obtained from the low-speed wind tunnel tests indicate that the rectangular-winged version of PLATO has the more desirable aerodynamic characteristics. The results contained in Reference 8, in which simple models without empennage were tested at supersonic speeds up to Mach 4.6, also support this conclusion. However, wind tunnel tests at supersonic and, later, at hypersonic speeds will be needed to confirm the superiority of the rectangular-winged configuration.

4 CONCLUDING REMARKS

The PLATO concept is being developed with the aim of providing European autonomy in the operation of unmanned, recoverable space platforms. Simplicity in the realization of the concept and the minimization of costs are key factors adopted for its development.

The first phase of the feasibility study of PLATO has investigated its ascent, re-entry and return flight phases by means of computer simulations, analyses and low-speed wind tunnel

tests. The results obtained so far are considered promising and to have sufficient margin to allow further development of the concept.

The study has demonstrated that it is possible to combine unconventional ideas. At the same time, it has generated basic data for the application of very low aspect ratio wings, thick supercritical aerofoil sections and active control technology to re-entry vehicles. It has also identified new areas of research.

ACKNOWLEDGEMENTS

The authors thank the German Ministry of Research and Technology and the Directors of MBB/ERNO for their permission to publish this paper. They are indebted to Mr Gerd Götz, DFVLR Study Manager, and colleagues for their contributions to the PLATO study.

REFERENCES

- (1) AEROSPATIALE, MBB/ERNO and CASA. EURECA/Ariane adaptation study. Final Report, 1987, Estec Contract 6884/86/NL/PR.
- (2) AEROSPATIALE. EURECA/Ariane 4 compatibility assessment. Final Report, 1987, Estec Contract 6884/86/NL/PR.
- (3) MBB/ERNO and MATRA. Mission definition study of in-orbit servicing of EURECA platforms by Hermes. Final Report, 1986, Estec Contract 6594/86/NL/PR.
- (4) MILLER, J. *The X-Planes. X-1 to X-29*, 1983, 148-155 (Specialty Press, USA).
- (5) NASA. Flight test results pertaining to the Space Shuttlecraft. NASA TM-X-2101, 1970.
- (6) ZIMMERMAN, C.H. Characteristics of Clark Y airfoils of small aspect ratios. NACA Report 431, 1932.
- (7) WINTER, H. Strömungsvorgänge an Platten und profilierten Körpern bei kleinen Spannweiten. VDI Sonderheft - Luftfahrt, 1936, 14-29. NACA TM-798 (Translation).
- (8) STALLINGS, R.L., Jr and LAMB, M. Wing-alone aerodynamic characteristics for high angles of attack at supersonic speeds. NASA TP-1889, 1981.
- (9) ESCH, H. Normalkraft- und Kippmomentmessung an schlanken Flugkörperflügeln im Überschall bei großen Anstellwinkeln. DFVLR Bericht 222-81-K-6, 1981.
- (10) BERTING, R. Untersuchungen von Wiedereintrittskörpern bei Unterschallströmung. Forschungsbericht DF/1/11/88, 1988, Institut für Luft- und Raumfahrt, RWTH Aachen.
- (11) RANSOM, S. PLATO - Analyse der Messungen im Niedergeschwindigkeitswindkanal. MBB/ERNO Technische Bericht TB-PL-004-88, 1988.

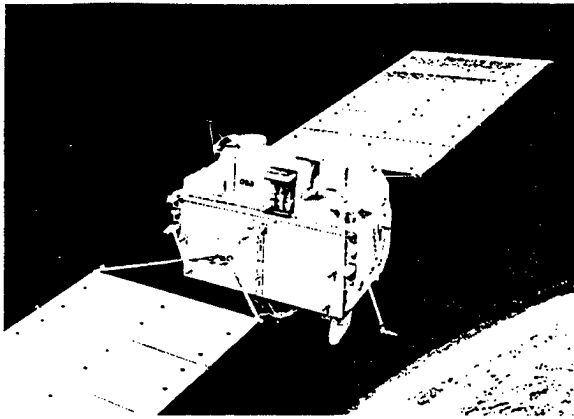

Fig 1 The European Retrievable Carrier (EURECA)

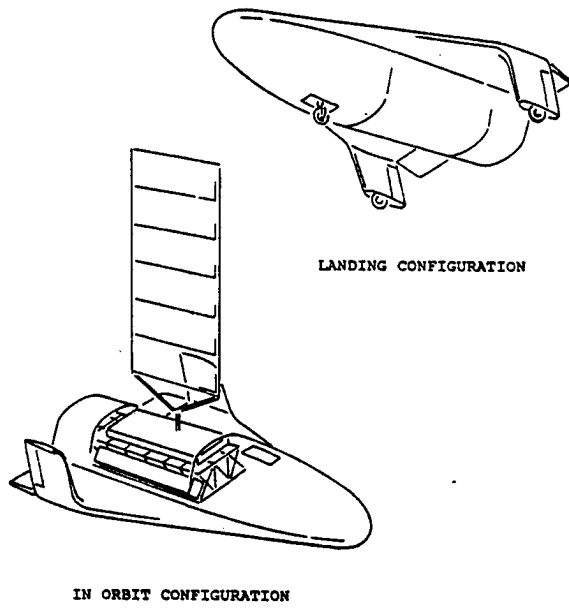

Fig 2 Initial PLATO configuration

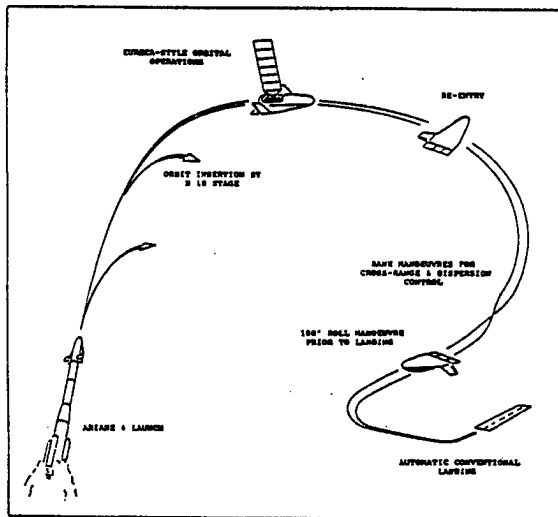

Fig 3 PLATO's operational scenario

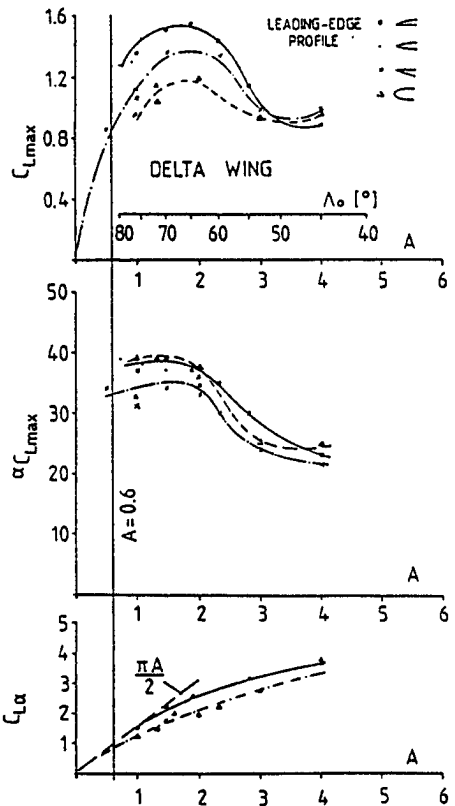
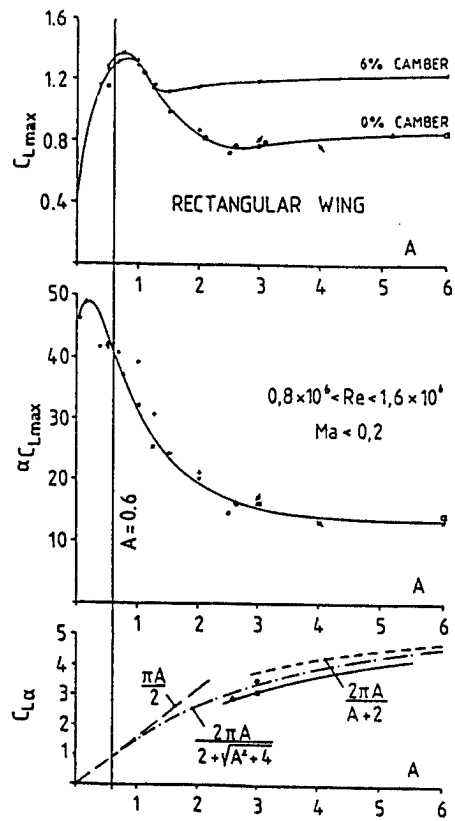
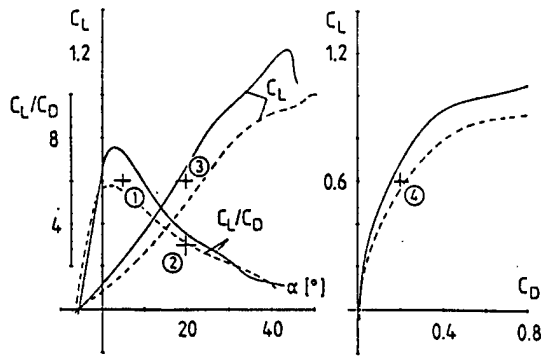

Fig 4 Comparison of empirical data for rectangular and delta wings



RECTANGULAR WING - CLARK Y Aerofoil Section

A=0.65 $\lambda=1.0$ $\Lambda=0^\circ$ $Re=0.86 \times 10^4$

A=0.90 $\lambda=1.0$ $\Lambda=0^\circ$ $Re=0.86 \times 10^4$

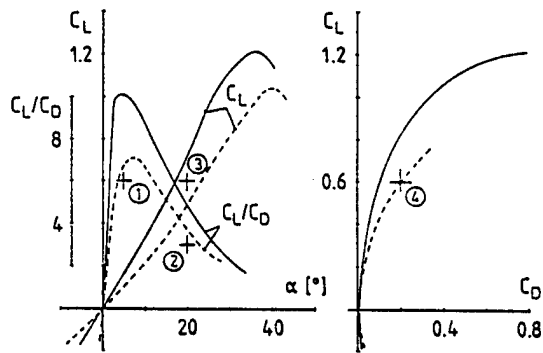
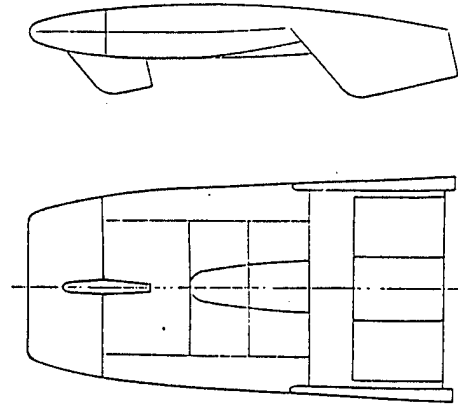

DELTA WING - NACA 0012 Aerofoil Section

A=0.83 $\lambda=0.125$ $\Lambda=76^\circ$ $Re=1.21 \times 10^4$

A=1.33 $\lambda=0.25$ $\Lambda=61^\circ$ $Re=1.18 \times 10^4$

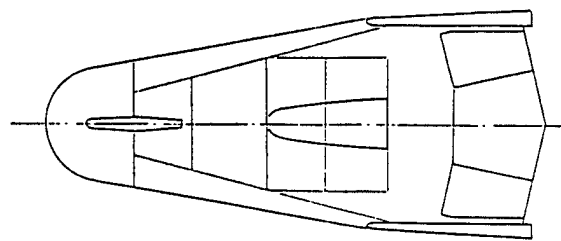

Launch mass	5000 kg
Re-entry mass	4500 kg
Payload mass	800-1000 kg
Span	6.4 m
Wing area	67.7 m ²
Wing aspect ratio	0.6
Length: Rect. wing	12.0 m
Length: Delta wing	14.2 m

Fig 5 Comparison of low speed characteristics of rectangular and delta wings

Fig 7 PLATO configurations investigated during the feasibility study

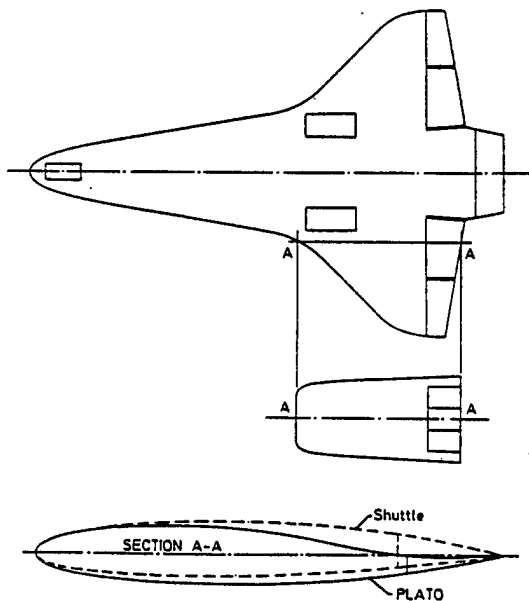

Fig 6 Comparison of PLATO and Shuttle wing sections

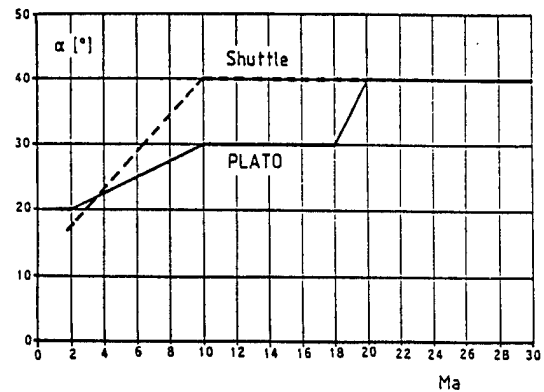

Fig 8 PLATO re-entry incidence profile

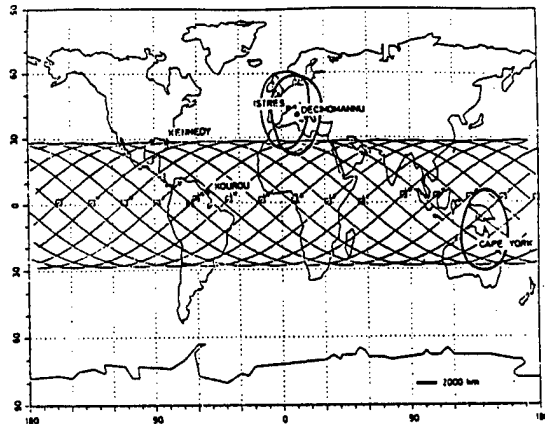

Fig 9 PLATO's cross-range capability from a 28.5 degree orbit. Plot shows orbits during first 24 hours after launch

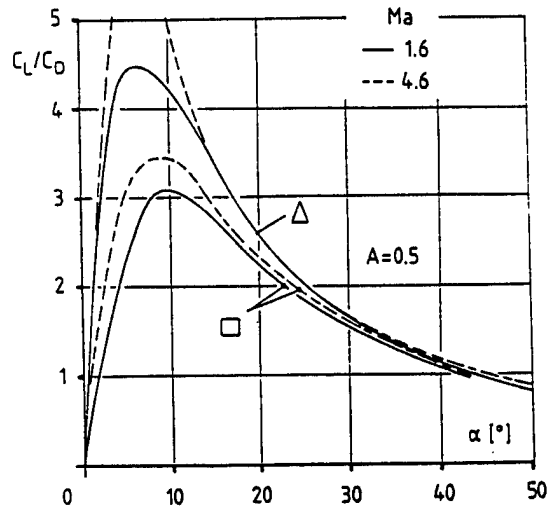

Fig 10 Lift/drag ratios obtained from Ref 8 and used in re-entry computer simulation

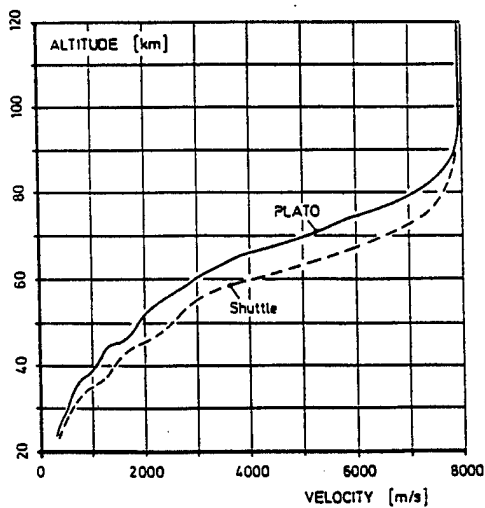

Fig 11 Re-entry profile

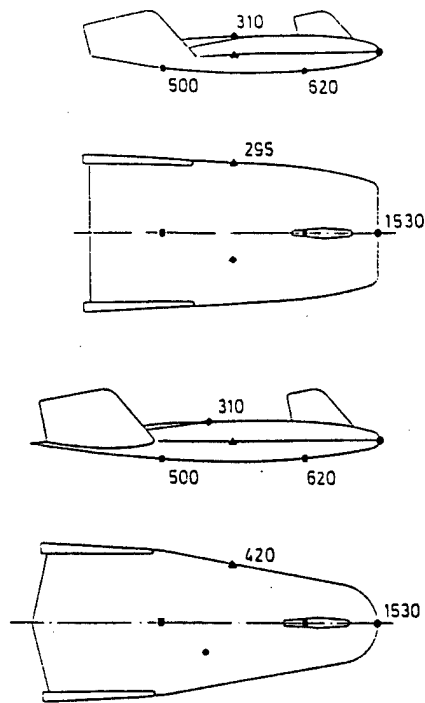

Fig 12 Maximum surface temperatures (°C)

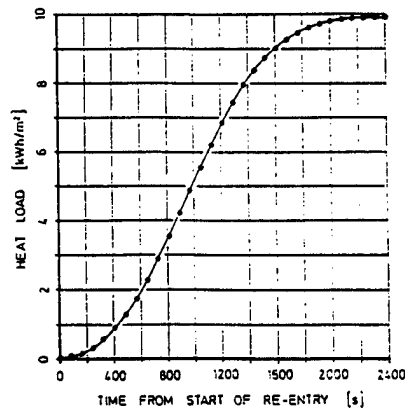
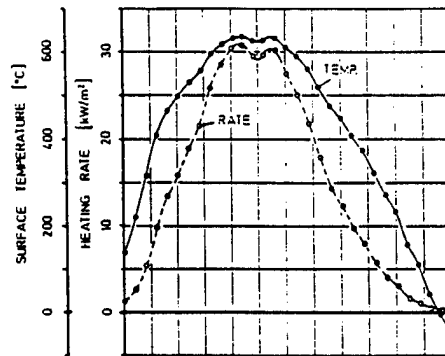

Fig 13 Results from preliminary thermal analysis. Data are for a point 3 m from the nose and on the centre-line of the lower surface

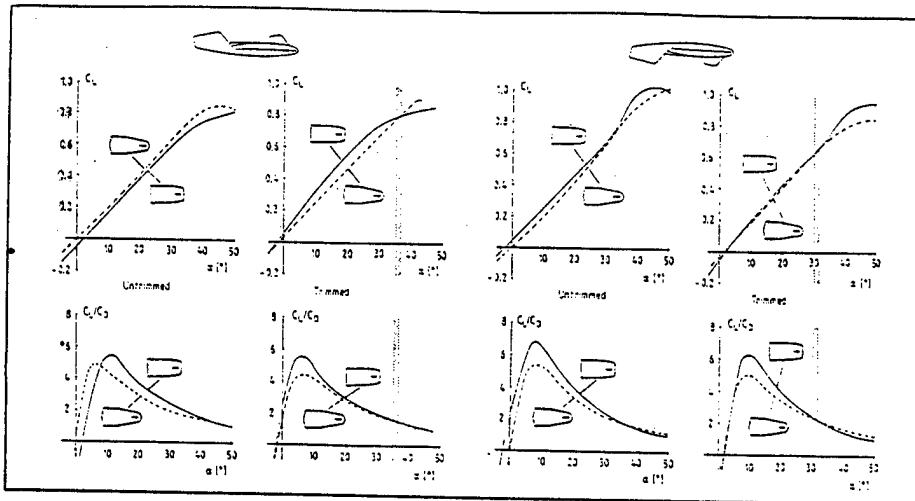

Fig 14 Comparison of PLATO's trimmed and untrimmed longitudinal characteristics

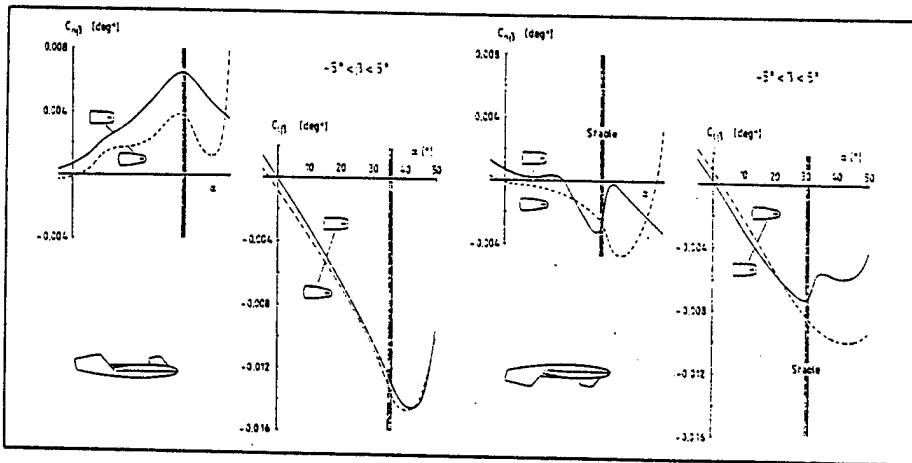

Fig 15 Comparison of PLATO's untrimmed lateral characteristics

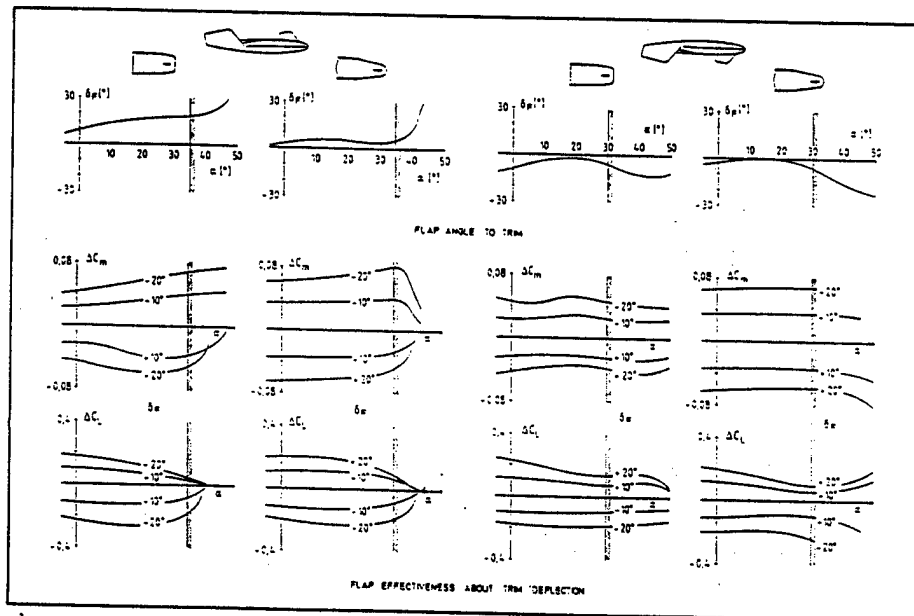

Fig 16 Trailing-edge flap characteristics

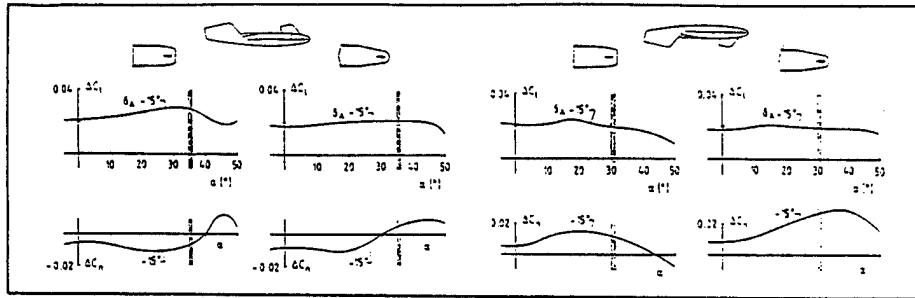

Fig 17 Aileron characteristics

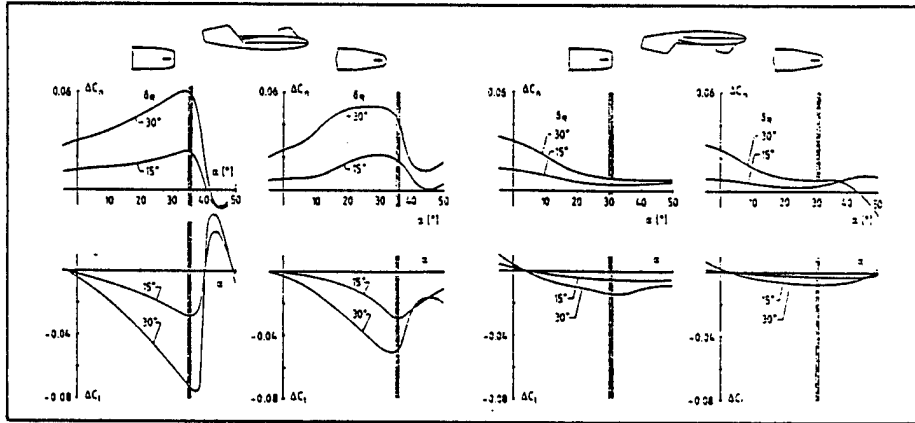

Fig 18 All-moving fin (rudder) characteristics

HOTOL space transport for the 21st Century

by Mr B R A Burns,
British Aerospace (Military Aircraft) Ltd.

SYNOPSIS The main structural, aerodynamic and systems engineering features of HOTOL and their evolution during the design study are described. Operational procedures are also outlined.

1 INTRODUCTION

The forecast expansion of satellite operations and space station activities in future years will be severely restricted without much cheaper and more dependable access to orbit than is possible with existing launch systems. A new advanced space transport must be totally reusable, highly reliable and operable with minimum support staff.

Reusable launch vehicles or "Aerospaceplanes" are being studied in UK, W. Germany, France, USA, Japan and USSR. These feature different propulsion concepts; some are two-stage vehicles, others single stage. Air-breathing propulsion units exploit the unlimited, free supplies of atmospheric oxygen for propellant combustion, at the expense of higher drag losses and dynamic pressures acting on the vehicle. Two-stage vehicles are inherently less sensitive to mass and drag growth than single-stage vehicles, but are inevitably heavier and therefore more costly to develop and produce. They are also more expensive and less reliable to operate because of their more complex mating, separation, control and recovery procedures. For these reasons, BAE's favoured launch vehicle design, HOTOL, features:

- o Single stage to orbit
- o Hybrid air-breathing/rocket propulsion
- o Horizontal take-off and landing
- o Autonomous, unmanned operation in its primary role of satellite launch and recapture

2 SSTO - THE DESIGN CHALLENGE

It is recognised that Single Stage to Orbit (SSTO) is more difficult than Two-Stage because every unit of inert mass (structure, propulsion, internal systems and insulation) has to be accelerated to orbital velocity, nearly 8 kilometres per second; any local mass increase incurs a growth factor of 20 or more due to the additional propellant, structure, insulation and power unit mass required to accelerate it to orbital velocity. That places a very high premium on mass saving.

The principal constituents of the mass of the HOTOL SSTO air-breathing launch vehicle are:

Propellant	80% (56% Lox; 24% LH ₂)
Structure	9%
Propulsion, including intake	6%
Systems	2%
Payload	3%

Clearly, with such a high propellant fraction, engine efficiency is all-important. This is conventionally expressed as Specific Impulse. Figure 1 illustrates the envelopes of Specific Impulse vs. thrust/weight ratio for various candidate power units for launch vehicles. The general trend is for fuel efficiency to be associated with heavy intakes, turbo-machinery and nozzles, so the optimum power unit must combine the best features of air-breathing and rocket propulsion.

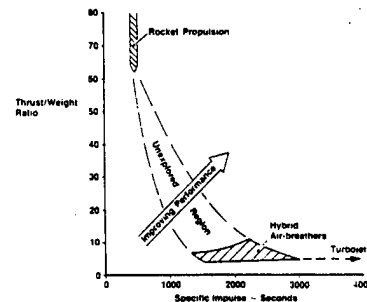

Candidate Power Units for Launch Vehicles

Figure 1

Horizontal take-off, by comparison with vertical launch, allows a much smaller thrust/weight ratio, so the power unit scale may be optimised for the orbital ascent. Air-breathing propulsion avoids the heavy mass penalty of on-board liquid oxidant (Lox) in the low speed, low altitude phase of the ascent, where rocket propulsion is inefficient, but it results in a relatively heavy power unit, used only on the initial part of the ascent. That emphasises the need to minimise the propulsion fraction of vehicle mass and therefore the required thrust/

weight ratio. Those considerations, and the necessity to adopt a "fast and low" climb profile while air-breathing, to maximise energy gained to fuel burnt, that is

$$\frac{(\text{Thrust-Drag}) \times \text{Speed}}{\text{Weight} \quad \text{Fuel Flow}}$$

places great importance on minimising drag, particularly wave drag in supersonic flight.

Figure 2 illustrates the sensitivity of payload to percentage variations in estimates of mass, drag and engine efficiency (Specific Impulse, S.I.). The extreme sensitivity to rocket S.I. is evident, but this can be established with little error, certainly within $\pm 2\%$, at an early stage. Sensitivity to air-breathing S.I. is much less because of the comparatively small proportion of total propellant used in this phase. That is not denigrating its usefulness; the proportion of fuel used to attain the same velocity would be much higher with pure rocket propulsion.

Sensitivity to structure mass is high. Careless design can easily increase mass by 10% which would reduce payload by 33% or increase GLOM by 20%.

Sensitivity to drag seems low by comparison but drag estimation on such vehicles is an inexact science and extreme care is needed even to design within a tolerance of $\pm 10\%$ in the early stages.

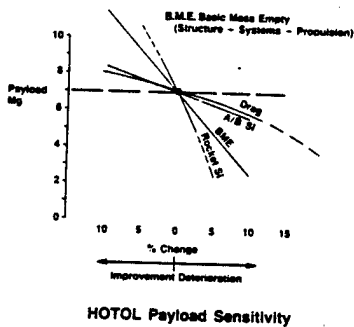
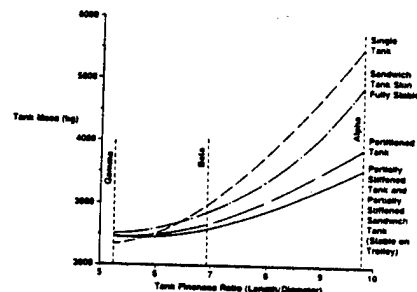

Figure 2

The liquid hydrogen tank is roughly 30 metres long, 6 metres average diameter, with a capacity of about 900 cubic metres. This component, apart from containing the primary fuel, is a load-carrying structure. Design loads are imposed by manoeuvre and gust loads (aerodynamic + inertia) on the ascent (tank nearly full) and by trolley support loads. Lateral loads due to gusts on the fin and nosewheel loads on the landing are relatively small. The tank is pressurised to ensure satisfactory propellant supply and this also relieves compression loading in the skin.

The tank must contain liquid hydrogen at 20 K on the ascent. On recovery, when empty, its temperature is allowed to rise, venting residual gaseous hydrogen, towards the limiting temperature of its structure.

The material chosen for the tank structure is carbon-peek (poly-ether-ether-ketone reinforced by carbon fibres). This thermoplastic material, manufactured by ICI, has been chosen not only for its high strength/weight ratio, but also its resistance to cracking and crazing and its impermeability at cryogenic temperatures. Titanium, although competitive in mass terms with a very thin skin, has been rejected on the grounds of susceptibility to cracking, difficulty of crack detection and repair. Thermoplastic materials are inherently easier to repair. A partially stiffened sandwich structure with peek foam in the core forming cryogenic insulation and facing skins of carbon-peek, has enabled a lighter, stiffer structure than a pure monocoque design, allowing more slender lines without excessive mass.



HOTOL Liquid Hydrogen Tank Skin Mass Sensitivity to Fineness Ratio

Figure 4

3 STRUCTURAL DESIGN

The main load paths through the structure are illustrated in figure 3. Features of particular interest are discussed below.

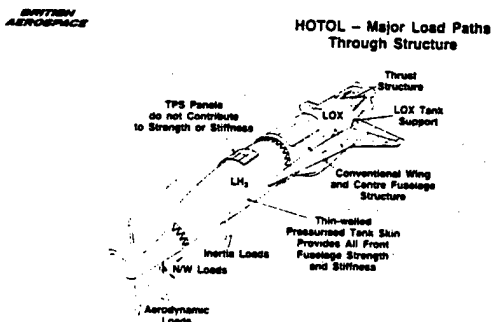

Figure 3

On a reusable launch vehicle the structural design and choice of materials are dictated largely by the peak temperatures experienced on re-entry into the Earth's atmosphere. HOTOL, by comparison with the U.S. Space Shuttle, has a much larger plan area, due to its internal tankage. Its lower planform loading means that it decelerates more rapidly as it re-enters the atmosphere so its peak heating rate, proportional to

$$\text{density} \times \text{velocity}^3$$

is much lower and peak temperatures are about 250°C cooler. The distribution of skin temperature at peak heating rate on HOTOL is shown in figure 5.

Peak Radiation Equilibrium Temperature Contours for the -0°C vehicle during re-entry.

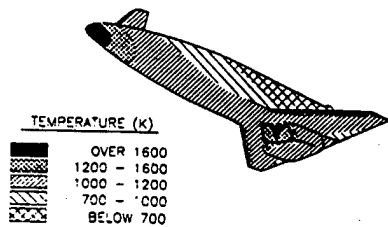
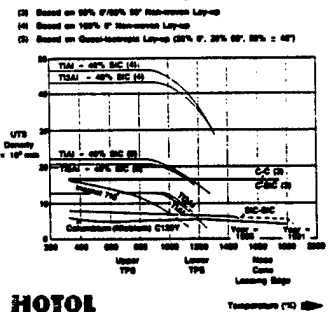

Figure 5

The stagnation regions on the nose cone, leading edges of wings and fin, intake lips and forward-facing intake doors are subjected to temperatures of about 1750K. (Also, most of the intake structure is subjected to at least 1200K on the ascent). The favoured material for these components is either carbon-carbon (C-C) or Carbon-Silicon Carbide (C-SiC), with sandwich structures for the nose cone and leading edges. C-C is used on the U.S. Space Shuttle but components are short-lived due to oxidation and consequent erosion when subjected to high temperatures. C-SiC has higher inherent resistance to oxidation and, on European evidence, has superior strength/weight ratio (fig. 6). Vigorous development of either or both of these materials is necessary to achieve high strength/weight ratio with inherent resistance to oxidation over the full vehicle life. That development is already under way by British manufacturers, in association with British Aerospace. Metallic alternatives would be unacceptably heavy.

ENVIRONMENTAL AERODYNAMIC Specific Strength Versus Temperature for a Number of Material Types Being Considered for HOTOL - High Temperature Range



HOTOL

Figure 6

Along the lower surface centre line the temperature is about 1200K, reducing to 700K on the upper surfaces. The thermal protection system (TPS) for the LH tank consists of carbon-carbon sandwich panels on the outside with layers of insulation in the 300mm gap between the panels and the tank skin, (Fig. 7). The TPS panels are sized, to avoid panel flutter, at 1m by 0.5m; each one is linked to the tank surface by a hinged post to allow differential expansion and interlocked with adjacent panels, along its edges, with expansion gaps. The panels are joined in groups of 4 downstream, for "fail-safe" reasons.

They do not contribute to primary airframe strength or stiffness, but resist local surface pressures, thermal and acoustic loading. On the lower surfaces there are two types of insulation, Protecalor (high temperature) and TG 15000 (lower temperature). Away from the hotter regions the lighter TG 15000 forms the total layer.

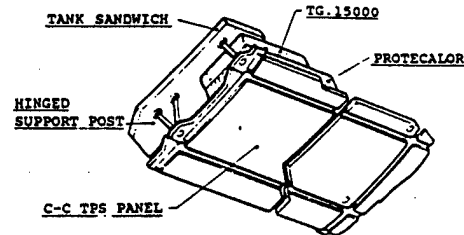

DETAIL OF THERMAL PROTECTION SHIELD PANEL

Figure 7

The centre fuselage, containing the payload bay, and the rear fuselage, containing the propulsion units, are of relatively conventional airframe construction of stressed skin, frames and longerons. Titanium (Ti) reinforced with boron-carbide (B_4C), a metal matrix material (MMC) is proposed for these components, subjected to temperatures approaching 700K. At that temperature Ti + B_4C has about 50% higher strength/weight ratio than conventional titanium (fig. 8). However a great deal of development work is necessary on forming and bonding these materials, using particulates where isotropic properties are required and long fibres where loading is unidirectional (e.g. in longerons).

ENVIRONMENTAL AERODYNAMIC Specific Strength Versus Temperature for Candidate Materials for Major Structure

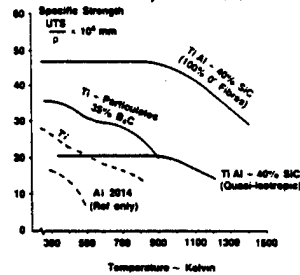

Figure 8

For the wing structure the same MMC material was originally specified, but this required a TPS over the lower (1200K) surface for protection against re-entry heating. That reduced the structural depth. The earlier design has now been superseded by a full depth structure in fibre-reinforced titanium aluminide (Ti-Al). Although the strength/weight ratio of Ti-Al is notably inferior to that of Ti + B_4C at lower temperatures, it retains sufficient strength at 1200K not to require a TPS and is therefore more efficient overall. Moreover, the internal volume with a full depth structure provides useful volume for carriage of LOX, also

relieving wing bending moments on the ascent.

4 AERODYNAMIC DESIGN

Low drag is of particular importance during the air-breathing ascent. During the rocket ascent the climb path is much steeper; with rocket power contributing to lift and air density diminishing rapidly, the importance of drag is greatly reduced.

Reduced drag has twofold benefits. It reduces fuel burnt and it allows a smaller engine scale. Reducing engine size (scale) increases fuel consumption, by decreasing the ratio of excess thrust to fuel flow, but the reduced inert mass improves the rocket climb, during which 80% of the propellant is used and the air-breathing components are "ballast".

The fuselage lines represent an optimum area distribution (due to Eminton) to minimise wave drag due to volume. However increased slenderness increases surface area and bending loads on the fuselage so weight increases, for both reasons. Consequently fuselage fineness ratio is a compromise between weight and drag and the optimum fineness ratio varies with engine scale, as illustrated in figure 9.

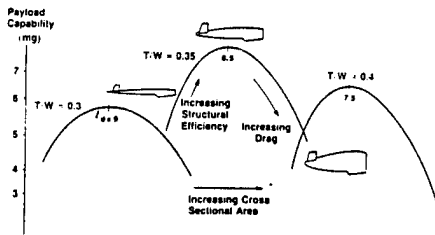

Derivation of Optimum Configuration

Figure 9

Similarly a thin wing reduces drag but weight increases, to restore both strength and stiffness. The optimum thickness/chord ratio, featured on the current design with a cropped delta wing of 54° L.E. sweep, is 7%.

The intake is sized by the engine air mass flow required at the top of the air-breathing ascent. Thrust must be maintained to sustain acceleration along the ascent trajectory so with a given air/fuel ratio this means that the product (air density x velocity x intake area) must be maintained. It is impractical to increase velocity in inverse proportion to air density. That would demand, for example, Mach 25 at 28km altitude, where air density is only 2% of its sea level value, with unreasonably high intake pressure and temperature. A practical ascent path approximates to constant dynamic pressure, or E.A.S., i.e. +

$$\text{density} \times \text{velocity}^2$$

More exactly, the optimum has been found to be constant EAS, changing to a constant intake pressure at high altitude, with air-breathing terminated at Mach 5, 28km. So, to maintain

air mass flow up to that point, intake capture area must be large. Consequently the intake is oversized for supersonic operation at low/medium altitude and great care must be taken to minimise spillage drag in these conditions. HOTOL's intake has undergone several design changes and now (fig. 10) features Twin Variable ramps on each side of a back to back vertical wedge intake, with an aft spill system. The ramp angles are varied to achieve maximum capture as Mach number varies and air flow is divided between engine demand and aft spill by flow control vanes. Hydrogen exhaust from the turbines is burned in the spill ducts, turning spillage drag into spillage thrust at moderate supersonic speeds.

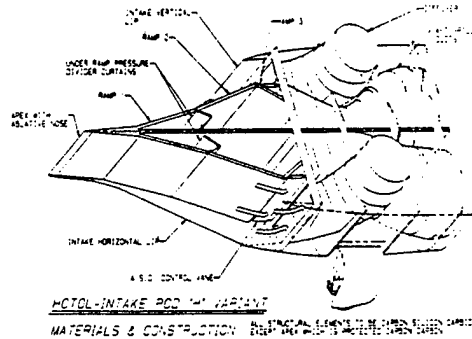

Figure 10

Improvements in the efficiency of the propulsion system and in structural design have enabled the engine scale to be reduced and low drag lines to be incorporated with acceptable weight penalty, resulting in the configuration depicted in figure 11.

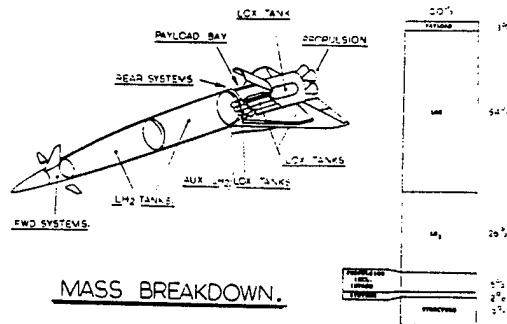

Figure 11

An SSTO reusable launch vehicle must embody propellant tanks of large volume which are empty during re-entry and recovery. The density of liquid hydrogen is very low (SG = 0.08) and the hydrogen tank of HOTOL, scaled for 275Mg at lift-off, contains 900 cubic metres of hydrogen in a tank about 30 metres long, 6 metres average diameter. The vehicle must traverse a very wide range of Mach number on both ascent and recovery, involving large changes in lift distribution between fuselage and wings. At transonic speed about 90% of the lift is on the wing, 10% on the fuselage, so the aerodynamic centre (a.c.) is well aft. By Mach 5 the distribution has changed to 50/50 and the a.c. is well forward.

The effects of these large changes in aerodynamics, and of variations in centre of gravity (c.g.) position as propellant is consumed can be very severe. Large pitching moments imply large control deflections to trim with consequent high hinge moments demanding heavy actuators and hydraulic power units to operate the controls. Figure 12 illustrates the measures that were taken on HOTOL to minimise the control moments and hydraulic systems weight.

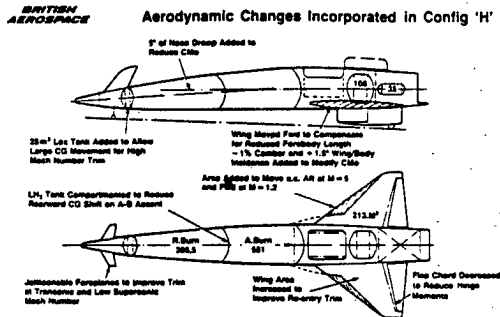

Figure 12

Changes in wing planform and area reduced total a.c. travel from 10m to 5m (fig. 13). Introduction of jettisonable foreplanes alleviated subsonic and transonic trim moments. The changes in wing and fuselage camber reduced the variation of "no lift moment" by 35%. Compartmentation of the hydrogen tank and introduction of a LOX trim tank in the nose allowed the c.g. to follow the a.c. forward during the ascent. Introduction of quadruplex in place of duplex hydraulic power supplies reduced the penalties of single hydraulic failures, a lighter solution overall. Figure 14 illustrates c.g. tracking during the ascent.

HOTOL: Effect of Modifications on a.c. Travel (HSWT Results)

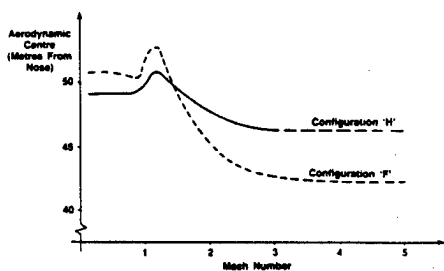

Figure 13

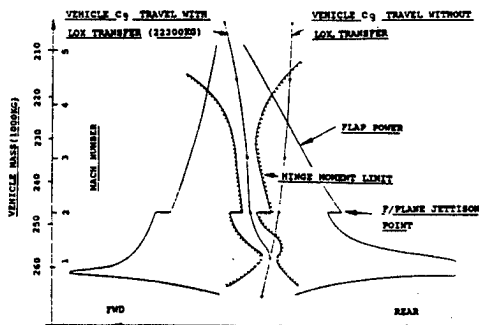

Figure 14

5 SYSTEMS DESIGN

As on the structure and propulsion systems, the emphasis in the design of hydraulic, electrical, 'spacionics', thermal control, propellant and auxiliary propulsion systems has been on lightness, but this has not been allowed to degrade safety. The fact that HOTOL is unmanned, in its primary role at least, makes little difference to safety targets which are set by economic considerations. Broadly speaking, safety critical systems which can fail 'active' (i.e. not merely stop working if defective, but oppose operative systems) are quadruplex. This allows continued safe operation after two failures. Safety critical systems which can fail passive only are triplicated. Mission critical systems are generally duplex. Figure 15 lists the main systems design features.

BRITISH AEROSPACE

HOTOL Systems

Guidance and Control	Quadruplex Computing Quadruplex Hydraulic Actuators Quadruplex Hydraulic APUs Forward (4), Thrusters Duales, Atmospheric Air Data Probe
Navigation	Quadruplex Laser Gyro + GPS Differential GPS for Landing Radio Star Tracker Radar Altimeter (1 + 2)
Sensors	Quadruplex Guidance and Control Bus Quadruplex Inertial Bus Mission Computer (2) Production Computers (2) Ultimate Processors (2) Payload Computers (2)
Communications	Single Transmitters (2) JPF-228
Thermal Control	Two Phase Attitude Loss Surface Radiators Water Coolers
Electrical Power	Battery (2)

HOTOL

Figure 15

The hydraulic systems in the nose, to operate the fin and nosewheel steering and in the rear to operate wing elevons and body flap are separate. Each is powered by quadruplex auxiliary power units (APU's); this is the lightest solution to satisfy the objective of surviving separate 'single system' failures, one on ascent and one on recovery, maintaining the capability to react full design loads at design operating rates. Intake ramps and main engine thrust vector control are powered from main engine offtakes. Heat is rejected from the hydraulic system when in operation on ascent and recovery to the thermal control system (TCS). On orbit, with hydraulics idle, the system cools and is then used as a heat sink from the TCS, to prevent hardening of the seals in the hydraulic system.

For the design mission of 50 hours duration electric power is provided by batteries. For longer duration missions fuel cells would probably be employed.

Auxiliary propulsion, for circularising the orbit at its apogee and for the de-orbit burn to initiate re-entry, is provided by the main engines in orbital manoeuvring system (OMS) mode. This is a lighter solution obviating the use of dedicated OMS thrusters, at the expense of some extra valves in the propellant supply. Propellants for the OMS burns are contained in separate, small tanks, separately insulated, to avoid the mass penalty of extra insulation on the main tanks.

The reaction controls, located in the nose region, rear fuselage and wing tips are powered by gaseous hydrogen and embody duplicated valves. Tankage for the reaction control system is also separate from the main H₂ propellant supply.

The main hydrogen tank is compartmented, the rear part being used during air-breathing propulsion to keep the c.g. forward. The forward part is used during the rocket climb. After main engine cut-off, that is on orbit and recovery, residual gas maintains tank pressure, being vented as the tank heats up on recovery.

Main LOX supply is contained in seven tanks, in wings (2), centre section (4) and engine bay (1), plus a trim tank in the nose. While this system requires a number of control valves, it saves a great deal of structure weight by comparison with a single tank in an extended fuselage. During the supersonic acceleration the nose tank is filled from the rear, by pump pressure, then during the rocket climb the LOX is allowed to return, to be consumed, longitudinal acceleration providing the pressure head.

The Thermal Control System utilises water boilers to cool the hydraulic systems, and pumped Freon loops to cool payload, electronics and batteries, rejecting heat on orbit via external radiators on the sides of the rear fuselage. During ascent and recovery, heat is rejected to a paraffin wax heat sink which can be re-frozen by circulation of vented hydrogen.

6 OPERATIONS

It is intended that HOTOL should be operated autonomously, making extensive use of rule-based systems in on-board and ground computing equipment to minimise support staff. HOTOL will take-off from a trolley (fig. 16). This avoids the mass penalty of an undercarriage designed for take-off, which would be roughly 5 times heavier than the landing gear and, with growth, add some 50% to take-off mass. The trolley will embody steering, auxiliary propulsion to save on-board fuel and power, retro-rockets and brakes. This will allow a safe abort at any point up to the start of rotation. Rotation is initiated hydraulically up to the point when aerodynamic control is sufficient to achieve a controlled lift-off at 280 knots EAS.

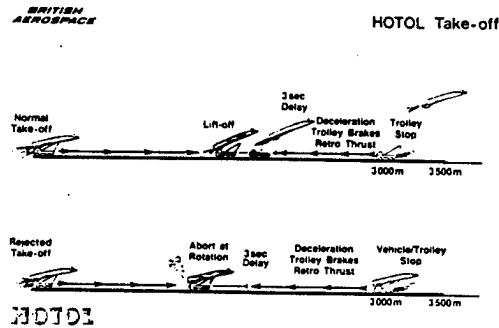

Figure 16

The ascent path (fig. 17) has been optimised from consideration of minimising fuel burnt versus structure mass penalty. It follows a constant EAS trajectory after initial acceleration, then a constant intake pressure profile up to the pull-up manoeuvre into the steeper rocket climb at Mach 5, 28km. On transition to rocket power the intake ramps are closed; the vehicle accelerates rapidly under the influence of rocket thrust and decreasing mass and some engine throttling is necessary as the 3g payload stressing limit is approached. Main engine cut-off is at 90km. altitude, the perigee of a low earth orbit.

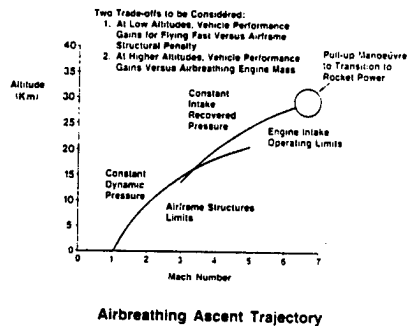

Figure 17

On orbit HOTOL will be guided primarily by signals from the 'NAVSTAR' constellation of Global Positioning System (GPS) satellites, providing precise latitude, longitude and altitude information. In the proving stage, while the on-board rule-based computers are being 'educated', use will be made of Data Relay Satellites and possibly relay aircraft for more continuous communication. Once past the learning phase, it is intended that HOTOL will communicate with the ground station only in one 5-minute 'window' per 1½ hour orbit for the transmission and reception of priority signals, possibly resulting in modifications to the mission plan. On-board computing will also deal with all foreseen failure possibilities and mission abort procedures.

For the de-orbit burn the vehicle is turned "tail-first", then re-orientated for the re-entry manoeuvre (fig. 18). The initial attitude is about 40° nose up, with a shallow descent path, maximising lift at hypersonic speed. Deceleration begins at about 80km, Mach 25. Peak

heating rate is attained after about 5 minutes and maintained for a further 5 minutes or so before reducing. Incidence is maintained high during this phase to maximise lift and deceleration rate, so to avoid 'skipping out' of the atmosphere as lift increases, the trajectory is controlled by varying bank angle. Once heating rate reduces, incidence may be reduced to increase lift/drag ratio and maximise glide range.

BRITISH AEROSPACE HOTOL Re-entry

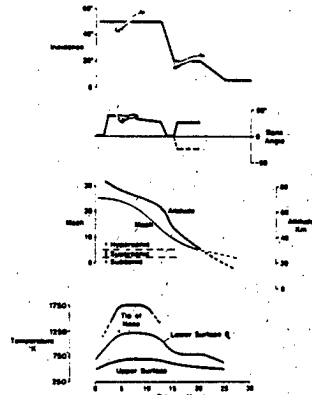

Figure 18

Recovery guidance is provided by GPS, inertial and air data signals, providing precise latitude, longitude and altitude information and their rates, and enabling computation of past and present wind. Together with forecast wind at lower altitude, this enables the vehicle to acquire the correct approach path. Initial approach is made at 280knots, 18° descent angle, somewhat faster than for maximum lift/drag ratio to allow glide control by speed variation (fig. 19). At about 1000m altitude transition is made on to a 3° decelerating glide path, to touchdown at 170 knots.

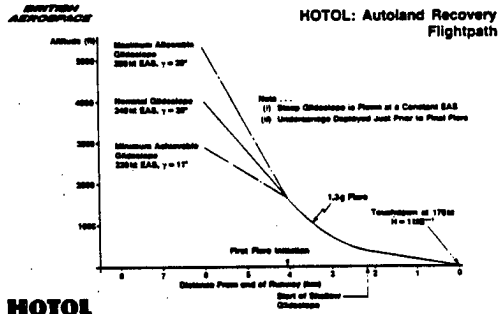
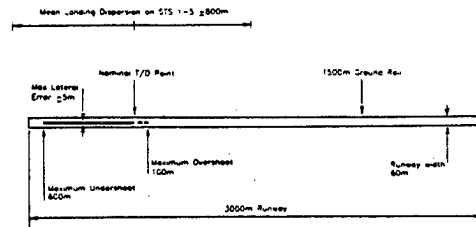

Figure 19

The autoland manoeuvre has been simulated using HOTOL aerodynamic data with a suitable Flight Control System design and tested in a wide variety of wind and turbulence conditions. Touchdown Scatter, in terms of lateral dispersion and vertical velocity, was very satisfactory (fig. 20). Longitudinal scatter was acceptable, and may be reduced to a satisfactory level by increase of target touchdown speed to reduce energy losses in turbulence.



SUMMARY OF TOUCHDOWN SCATTER OBTAINED DURING THE HOTOL AUTO-LAND SIMULATION STUDY

Figure 20

7 CONCLUSIONS

The HOTOL project has been engineered to a standard sufficient to be presented as a contender for a future European Advanced Space Transport for the 21st Century.

It is recognised that a great deal of effort must be expended on Enabling Technology in the fields of:

- Advanced Materials and Structures
- Hypersonic Aerodynamics (C.F.D. and W.T.)
- Command and Control (Autonomous Operation)
- Lightweight Power Generation and Actuation

before a Development Programme could be undertaken with confidence. Efforts are being made to initiate a co-operative European programme to address these topics.

Addressing the challenge of aircraft component design and manufacture from metal matrix composites

by Mr D Charles,
Development Engineer, British Aerospace (Commercial Aircraft) Ltd.

SYNOPSIS Metal Matrix Composites (M.M.C.) offer considerable potential for providing light weight components exhibiting high strength, high stiffness, good wear resistance and improved elevated temperature properties compared to the matrix alloy. Consequently they are applicable to a wide range of aerospace products. The potential offered by this class of materials has been recognised by British Aerospace plc and has resulted in considerable effort being expended to address the challenges posed by the design and manufacture of aerospace components from these material. These efforts have culminated in the successful design, manufacture and test of representative aircraft components from metal matrix composites.

1. INTRODUCTION

Metal matrix composites (MMC's) have considerable potential for providing light weight components exhibiting high strength, high stiffness, good wear resistance and improved elevated temperature properties in comparison to the matrix alloy. Consequently they are under consideration for the manufacture of a wide range of aerospace components. However, their utilisation has until recently been restricted due to the cost of material and the limited understanding of the design and manufacturing techniques required for the exploitation of this class of materials.

However, during the past few years intense development activities, both in the U.S.A., Japan and Europe, indicate that major price reductions are envisaged. It has been clearly shown that price is related to usage and therefore as the applications steadily increase the price is expected to fall sharply. Present fibre prices, for example, are considerably lower in real terms than in the early 1970's and since 1980 the cost of silicon carbide fibre has halved.

The U.S.A. Aerospace industry is continuing the high level of research activities with MMC's which commenced in the late 1970's. Recently material suppliers have delivered the sub-assemblies for a major demonstrator programme being carried out by Lockheed(1). Additionally it has also been revealed that Lockheed are now utilising a particulate reinforced aluminium M.M.C. material from DWA Composites Inc. on one of their current aircraft(2).

This material has proved to be superior even to the graphite/epoxy design initially proposed. However, the munitions list restrictions on information still makes it difficult to obtain much information on these programmes and applications.

MMC activities in Europe have increased significantly during the past few years. In fact, Aerospatiale are reported to be the largest purchasers of MMC's outside of the U.S.A. according to one American supplier. Virtually all of the engine manufacturers have active programmes and similarly to the U.S.A. are mainly working with titanium base MMC's. Perhaps the most accurate measurement of the application potential for MMC is through the investment by potential suppliers such as Alcan and B.P. which has led to the establishment of European sources of both continuous and discontinuous reinforced aluminium. The Japanese MMC programmes have increased significantly during the past few years and were recently reviewed through a D.T.I. sponsored mission.(3). They have a capability to supply a wide range of various reinforcements particularly with continuous fibre tows and discontinuous whiskers.

During 1985 the report of the Collyear Committee was published by the Department of Trade and Industry. The report emphasised that MMC's will have impact on; all transport industries including aerospace, industrial machining manufacturers, diesel engine manufacturers, component industries and material suppliers. It is emphasised that the aerospace industry is keen to exploit the material for structural components and needs to establish a manufacturing process technology.

The report also drew attention to U.S.A. restrictions on information and the Japanese interests and concludes that 'it is vital that the U.K. develop a capability in this area'.

The challenge emphasised by the Collyear Committee and the current worldwide activities in MMC's indicate their potential and likely application by competitors to the U.K. aerospace industry in all aspects of aerospace manufacture. The increasing availability of materials and forecasted realistic costs indicate considerable opportunity to achieve the potential offered by these exciting materials.

Since the beginning of the decade the Civil Aircraft Division of British Aerospace at Bristol has been involved in the development of MMC's. These projects have included manufacturing development, mechanical property assessment and design/application studies.

2. METAL MATRIX COMPOSITE TYPES

MMC's can be characterised by the method of reinforcement i.e., continuous reinforcement and discontinuous reinforcement. Under these headings the types of MMC's can be further divided as shown in Table 1.

Although not exhaustive, this table covers the main MMC reinforcements of current interest to the aerospace industry. The types of reinforcement employed play a dominant role in determining the component fabrication route, mechanical properties and finished part costs, further details of which are presented in reference 4.

3. MMC DEVELOPMENT AT BRITISH AEROSPACE

The Commercial Aircraft Division of British Aerospace plc, at Bristol has been involved with the development and evaluation of MMC's for several years. Since 1984 the project has been partially grant supported by the Department of Trade and Industry. The overall objective of the project is to develop low cost manufacturing techniques and demonstrate the potential of MMC's by applying these techniques to the design, manufacture and test of representative structures.

Although some work has been carried out on titanium matrix composites, virtually all of the development activities have been with aluminium matrix base MMC's. The first two phases of this project have now been completed and a B.Ae developed manufacturing technique scaled-up to enable representative structures to be successfully produced.

Table 1. MMC types

	Type	Materials
Continuous Reinforcement	Monofilament	Boron
		Silicon Carbide
	Multifilament (Tow or Yarn)	Carbon
		Silicon Carbide Alumina
Discontinuous Reinforcement	Particulate	Silicon Carbide
		Boron Carbide
	Whisker	Silicon Carbide
		Silicon Nitride Carbon
	Short Fibre	Alumina

The basic manufacturing technique for producing MMC parts by low pressure diffusion bonding methods was originally developed by British Aerospace in 1981 and a patent granted several years ago. The method developed allows the diffusion bonding of aluminium at low pressures (less than 7 MPa, 1,000 psi). The technique has been applied to the bonding of monotapes (single plies) of fibre reinforced aluminium. The procedure involves a lay-up and bonding process analogous to non-metallic composite part manufacture.

With partial grant aid from the Department of Trade and Industry B.Ae has developed the basic consolidation technique to enable a range of structural shapes such as 'Z', 'I', hat and channel sections, Fig.1. Metallographic examination of consolidated components has revealed little or no evidence of the original interfaces between monolayers Fig.2.

The objective of the first DTI supported programme was to design, manufacture and test idealised structures. To achieve this large compression panels representing both fuselage and wing sections were manufactured.

These panels consisted of particulate MMC skins and unidirectional continuous fibre reinforced 'Z' section struts. These panels were subsequently compression tested and either met or exceeded the predicted design failure loads, Fig.3.

Following the success of the initial programme, design studies have been carried out to identify potential structural applications for MMC's.

These design studies indicated that two components from the BAe 146 centre fuselage, Fig.4, could offer significant weight savings if redesigned and manufactured from metal matrix composites. The design, manufacture and test of these two components, Figs.5 & 6 was set as the objective of the next phase of the M.M.C. development programme.

To achieve this objective within the tight two year timescale, the programme was divided into key topic areas:-

- mechanical property assessment
- process development
- non-destructive testing
- representative structures

Summaries of the work carried out in these key topic areas are presented below.

3.1 Mechanical property assessment

Preliminary design studies using manufacturers data had indicated that significant weight savings over the current designs could be achieved for components manufactured from either continuous fibre reinforced aluminium or particulate reinforced aluminium.

In order to confirm the material suppliers property claims material was ordered for basic mechanical property assessment. Details of the tensile property assessment are presented below.

(a) Continuous fibre reinforced aluminium

The material selected for the representative structure designs was an AVCO SCS-2 silicon carbide fibre reinforced 6061 aluminium. This material was purchased from AVCO Speciality Materials as sheets containing a single layer of fibres (monotapes) which were subsequently consolidated into multilayers by low pressure bonding. The consolidated material contained a nominal fibre loading of 45% by volume. A comparison of the results obtained from this evaluation with manufacturers data is presented in Table 2.

(b) Particulate reinforced aluminium

The material selected for the representative structure designs was a 2124 matrix aluminium reinforced with 25% silicon carbide particulate by volume. This material was selected on the basis that the proposed particle loading would offer considerably improved tensile and compressive properties in addition to increased stiffness, over conventional aluminium and still offer a fracture toughness in the region of 20 MPa \sqrt{m} .

Material in the form of extruded plate and rolled sheet was purchased from DWA Composites Inc for evaluation. A comparison of the results obtained from the evaluation with manufacturers data is presented in Table 3.

Toughness testing indicated the initial extruded plate material to have a plane strain fracture toughness of 17 MPa \sqrt{m} . From these results it can be observed that there are some differences between the B.Ae data and the manufacturers data. Discussions with the material supplier have indicated that the material chemistry has been slightly modified to improve the materials workability and toughness. This modification was carried out after production of the initial extruded plate material. Consequently, the sheet material and component extrusions were expected to exhibit a small drop in elastic modulus and strength but with the correct degree of processing have improved ductility and toughness. Further testing has been planned to confirm this.

3.2 Process development

Due to the complexity of the final component designs considerable process development was required to establish the fabrication expertise for component manufacture in either continuous fibre reinforced aluminium or particulate reinforced aluminium.

Table 2. Comparison of data for tensile testing of SCS-2/6061 Al

Material	Lay-Up	Ftu (MPa)	E (GPa)	($\times 10^{-6}$)
B.Ae Bonded	100% 0°	1717	219	8530
AVCO Bonded		1462	204	8900
B.Ae Bonded	100% 90°	82.8	139	611
AVCO Bonded		86.2	118	800
B.Ae Bonded	[+45/-45/+45/-45]	236	82.7	20,000
AVCO Bonded		310	94.5	10,600
B.Ae Bonded	[0/90/+45/-45]	693	114	6,100
AVCO Bonded		572	127	10,000
B.Ae Bonded	[+45/-45/0/0]	942	182	8,160
AVCO Bonded		800	146	8,600

Table 3. Comparison of tensile test data for DWA 2124-25v/o SiCp

Material	Ft1 (MPa)	Ft2 (MPa)	Ftu (MPa)	E (GPa)	E1 (%)
Extruded Plate (L)	449	483	605	129	4.0
Strut Extrusion (L)	351	376	525	108	3.5
Rolled Sheet (L)	324	355	535	113	5.3
Rolled Sheet (T)	322	350	492	118	3.3
Suppliers Data	-	414	565	114	5.6

(a) Continuous fibre reinforced aluminium

At the outset of design studies the B.Ae low pressure bonding technology was confined to the production of simple geometries, primarily Z-section and flat plate, with unidirectional reinforcement. The proposed designs required this technology to be expanded into the production of 'I' sections and tubular components. The production of 'I' sections for the floor beam strut was successfully achieved using modification to the existing bonding technique. Unfortunately, within the programme time scale it was only possible to produce short lengths of continuous fibre reinforced aluminium tube.

Process developments were successfully carried out to extend the production technology into cross-ply components and investigate some of the limitations associated with this technology. The development of chemical pretreatments for adhesive bonding and painting was also successfully evaluated. Preliminary studies into the mechanical fastening and welding of these materials has also been initiated.

(b) Particulate reinforced aluminium

The two selected components are currently manufactured as extrusions and then machined to final size. For production of the metal matrix composite representative structures it was proposed to adopt a similar fabrication route as this offered the best material utilisation. At the time the programme commenced there was no U.K. or European source of particulate reinforced aluminium therefore the extrusions for the representative structures were purchased from the U.S.A. for finish machining in the U.K.

Two basic extrusions were purchased consisting of an 'I' section for floor beam strut manufacture and a tubular section for keel longeron tube manufacture. Although some machining difficulties were encountered the 'I' sections were successfully machined to final design by the use of tungsten carbide tipped tools. The tubular component was ordered as an oversize extrusion and therefore required considerable machining. It was found that the most successful method for removing this excess material was to use polycrystalline diamond tooling. With the use of such tooling the first of the tubes was successfully manufactured. Process developments have also been carried out to evaluate the weldability of the material and establish appropriate chemical pretreatment procedures.

3.3 Non-destructive testing

It was recognised that the adoption of advanced materials requires an evaluation of the inspection techniques that will be required for eventual component qualification and acceptance. Throughout the Basic Manufacturing Process Technology programme the area of the application of non destructive testing has been addressed. At present the work has concentrated on developing techniques for evaluating low pressure bonded continuous fibre reinforced aluminium.

The technique that has shown most promise to date has been ultrasonic 'C' Scan. This technique was initially only applicable to flat components but the necessary jiggling was developed during the programme to extend the process to more complex components. This enabled the fibre reinforced struts to be 'C' scanned prior to test. The 'C' scanning was able to successfully detect defects in one of the initial struts manufactured which were confirmed by metallography, Fig.7. This resulted in a modification to the fabrication procedure for subsequent struts which when 'C' scanned were shown to be defect free.

3.4 Representative structures

The design studies indicated that the following representative structures offered considerable weight savings -

- B.Ae 146 floor beam strut manufactured from low pressure bonded silicon carbide fibre reinforced aluminium
- B.Ae 146 floor beam strut manufactured from 2124 aluminium reinforced with 25% by volume of silicon carbide particles
- B.Ae 146 undercarriage bay keel longeron Tube manufactured from low pressure bonded silicon carbide fibre reinforced aluminium
- B.Ae 146 undercarriage bay keel longeron Tube manufactured from 2124 aluminium reinforced with 25% by volume of silicon carbide particles

Within the timescales of the programme it proved possible to successfully manufacture and test both types of floor beam strut, Figs.8 & 9 but only manufacture the particulate reinforced tube, Fig.10 and a short length of continuous fibre reinforced tube.

The results from this assessment are being applied to the design, manufacture and test of a full civil aircraft structural demonstrator in order to identify whether the predicted weight savings can be achieved cost effectively.

4. CONCLUSION - THE WAY FORWARD

Although not detailed in this paper, British Aerospace plc has worked closely with universities, government research institutions and major U.K. Companies to ensure the success of the partially D.T.I. supported Basic Manufacturing Process Technology programme for metal matrix composites.

It is believed that the way forward to unlocking the potential offered by MMC's will be through similar programmes leading to major structural demonstrators and the eventual adoption and full utilisation of cost effective M.M.C. components.

5. REFERENCES

- (1) Aviation Week & Space Technology
28.11.88
- (2) Advanced Materials 9.1.89
- (3) Industry/OSTEM visit to Japan -
October 1986. Harwell Report by
Dr. A. Feest - Harwell,
Mr. M.J. Ball - B.Ae,
Dr. A. Begg - B.P.,
Dr. D. Bigg - Ford
- (4) The Challenge & Potential of Metal
Matrix Composites, M.J. Ball
presented at Aerotech '87

Acknowledgement

In thanking British Aerospace for permission to publish this paper the Author emphasises that, although it is based on his professional work on the Company's behalf, any views expressed are his own and do not necessarily represent those of the Company.

**BRITISH
AEROSPACE**

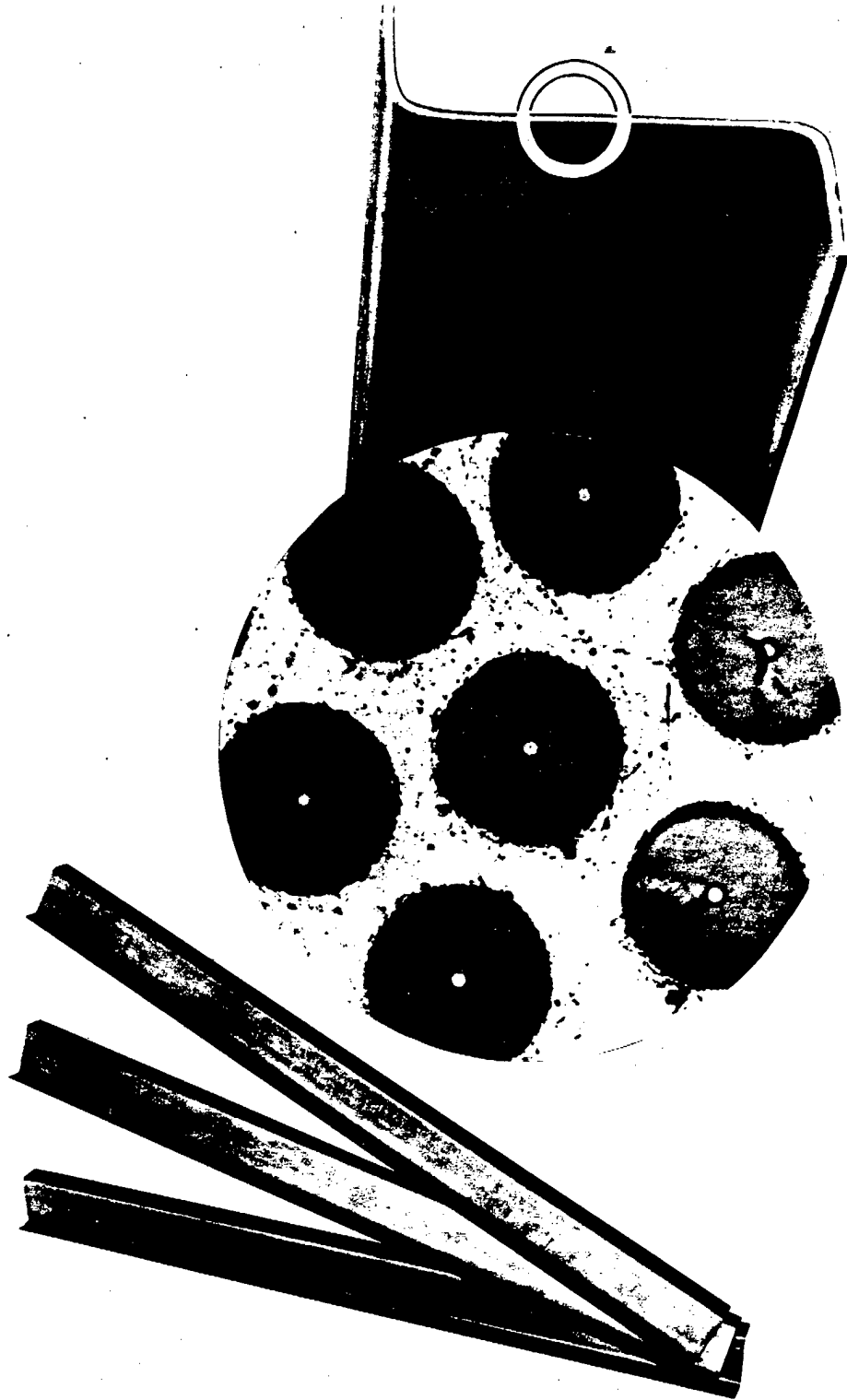

Fig.1 - Low pressure bonded Z-section stringers

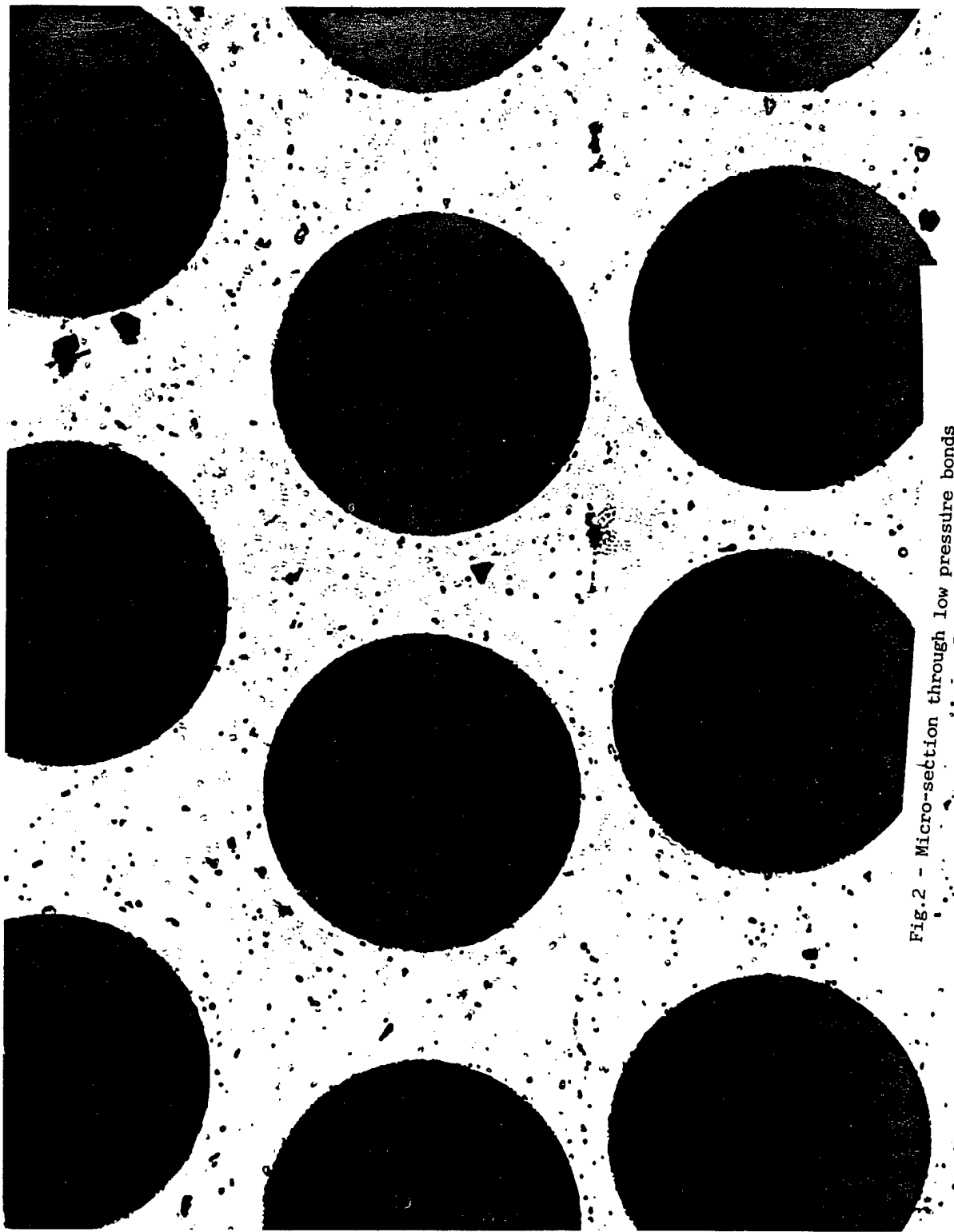
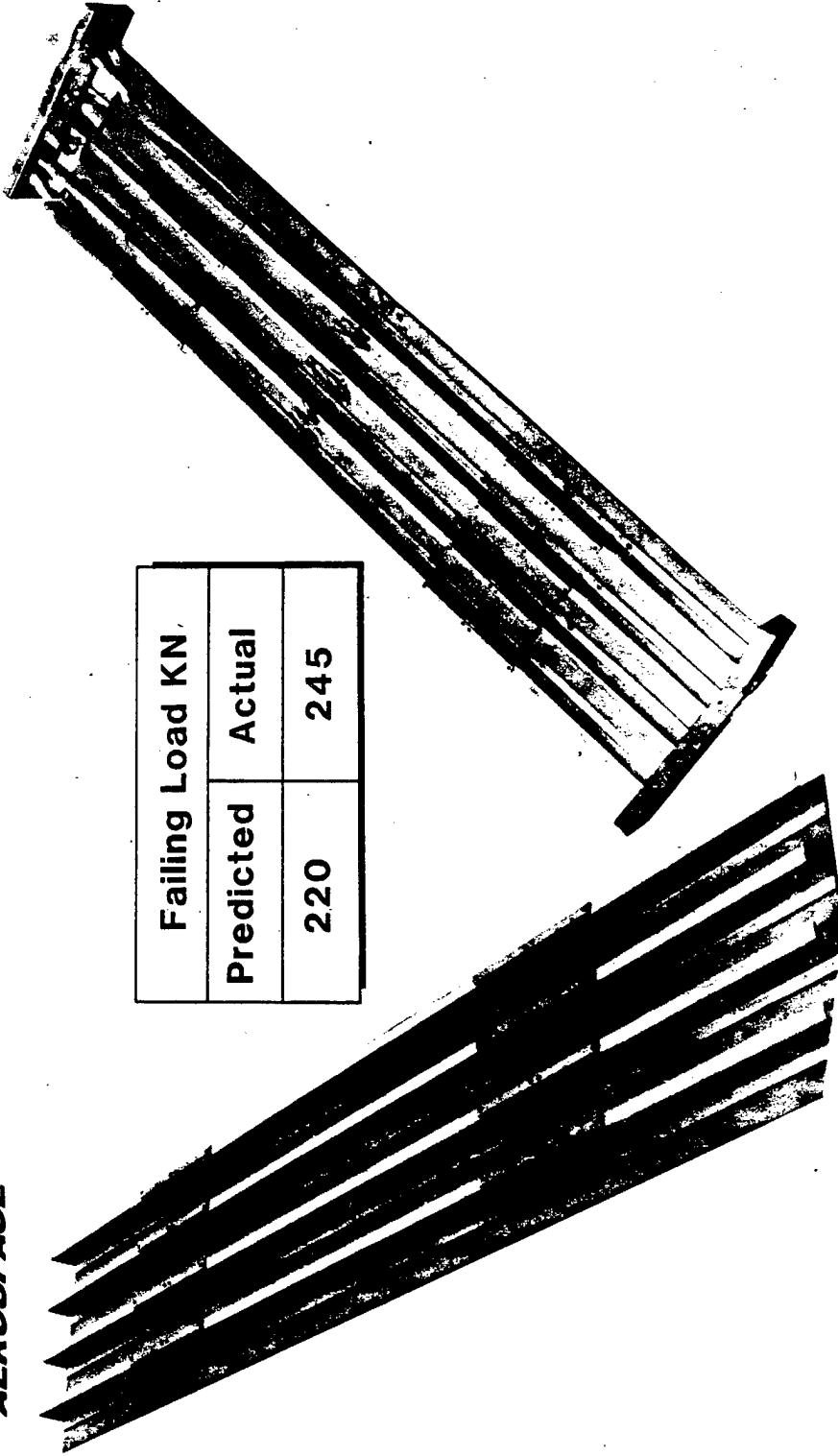

Fig.2 - Micro-section through low pressure bonds

**BRITISH
AEROSPACE**



Failing Load KN	
Predicted	Actual
220	245

Fig.3 - Metal matrix composite skin stringer panel

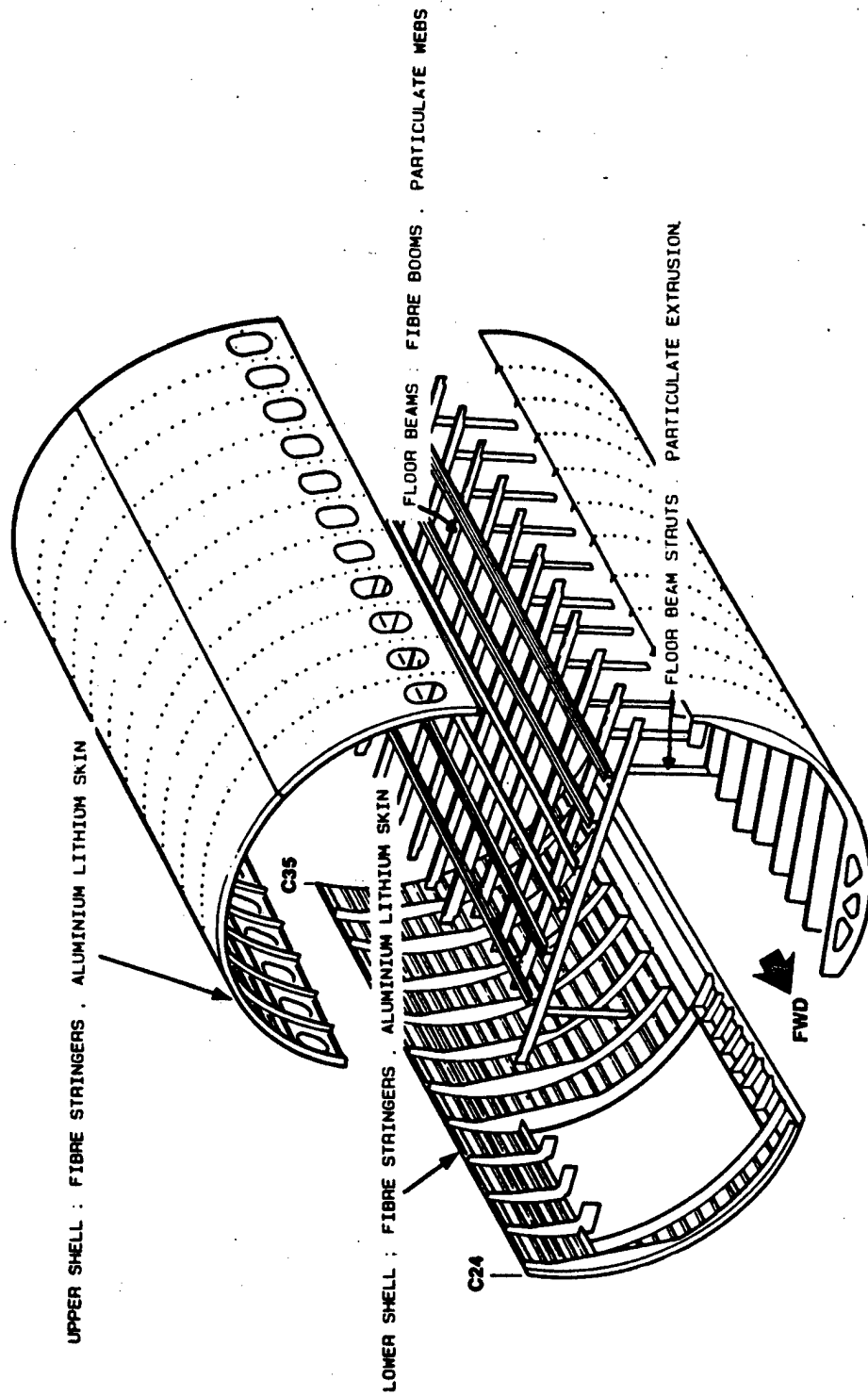

Fig.4 - BAe 146 Centre Fuselage - Potential new materials

Floor Beam Strut

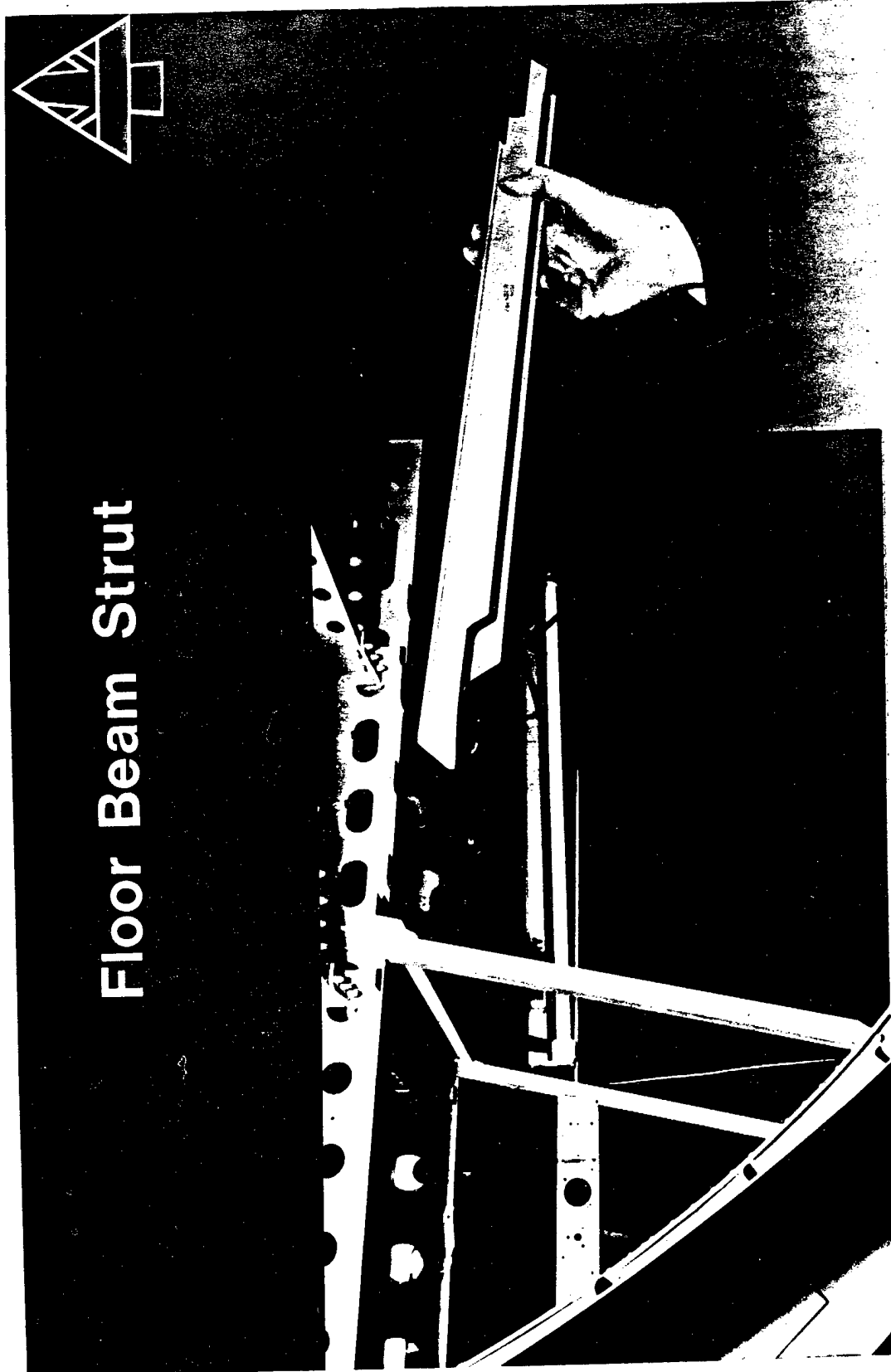
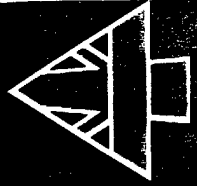

Fig.5 - BAe 146 Floor Beam Strut

ABL MB17 0389

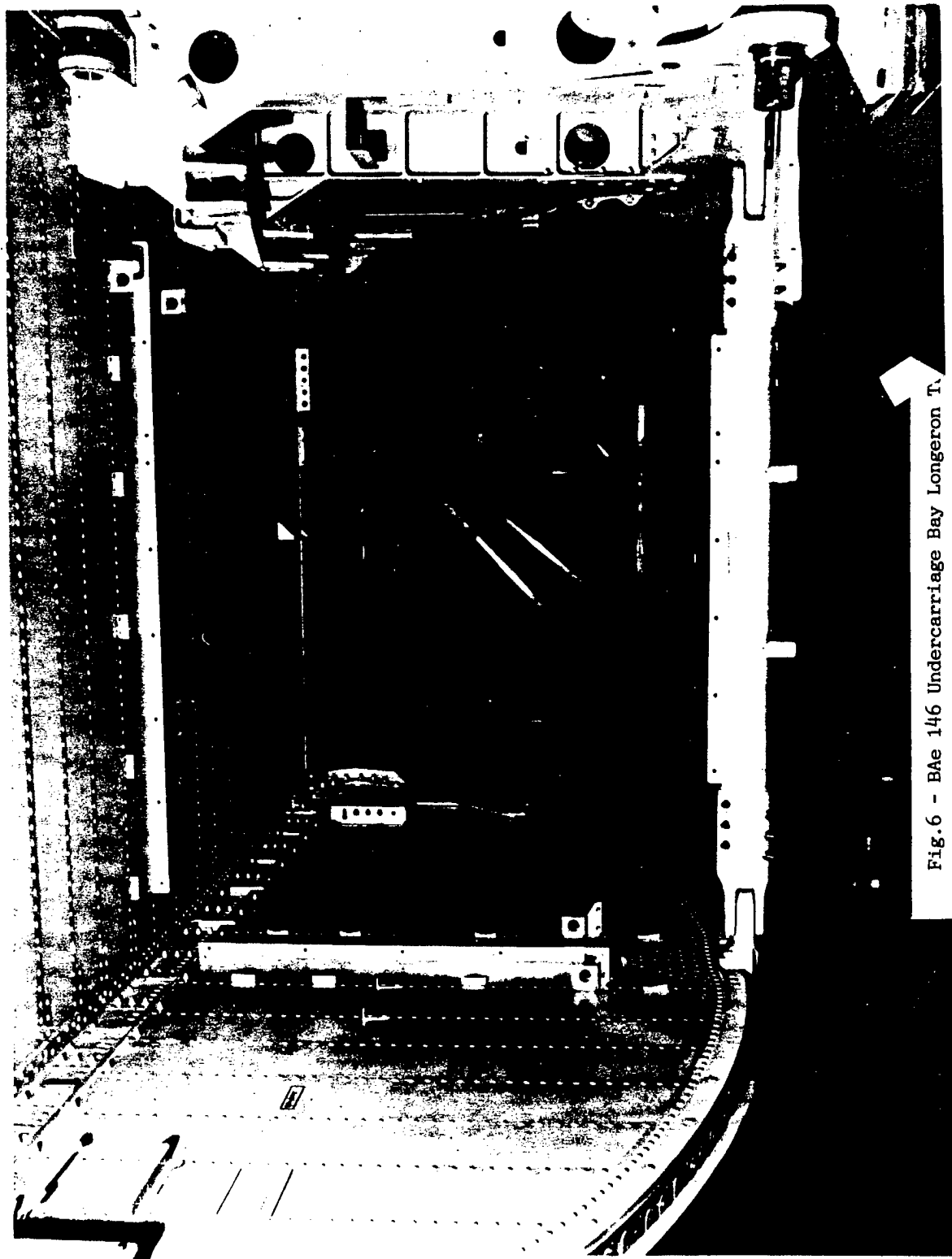

Fig.6 - BAe 146 Undercarriage Bay Longeron T.

Section of C-Scan Detected Region of Poor Bonding

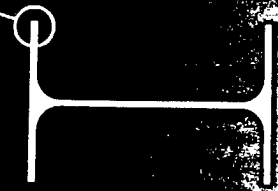
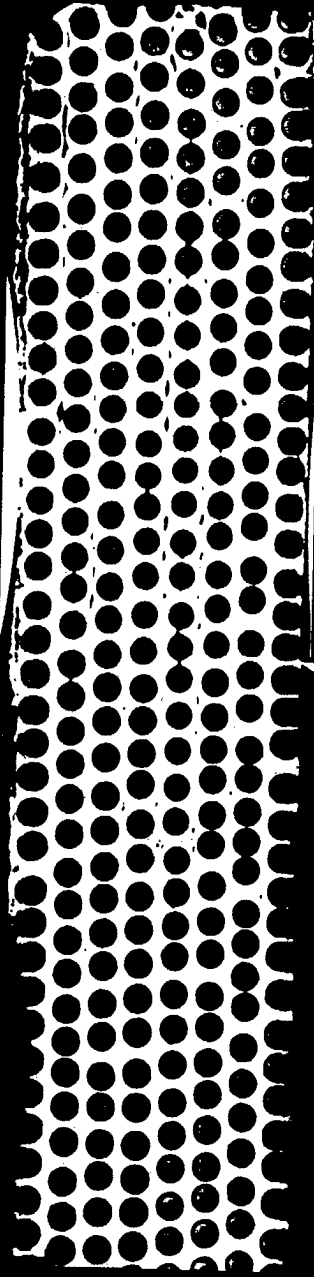
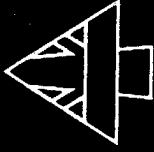

Fig.7 - Section of C-Scan detected region of poor bonding

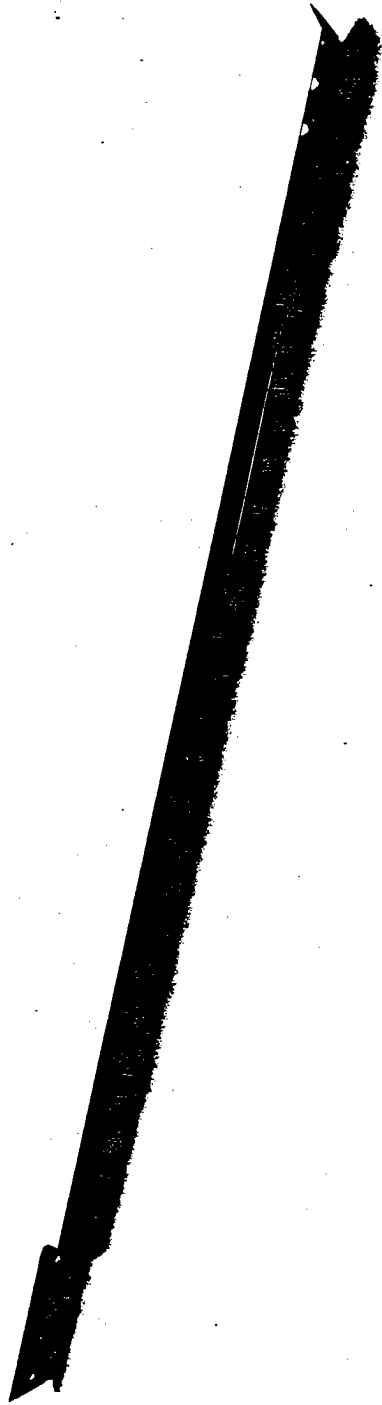

Fig.8 - Fibre reinforced Floor Beam Strut

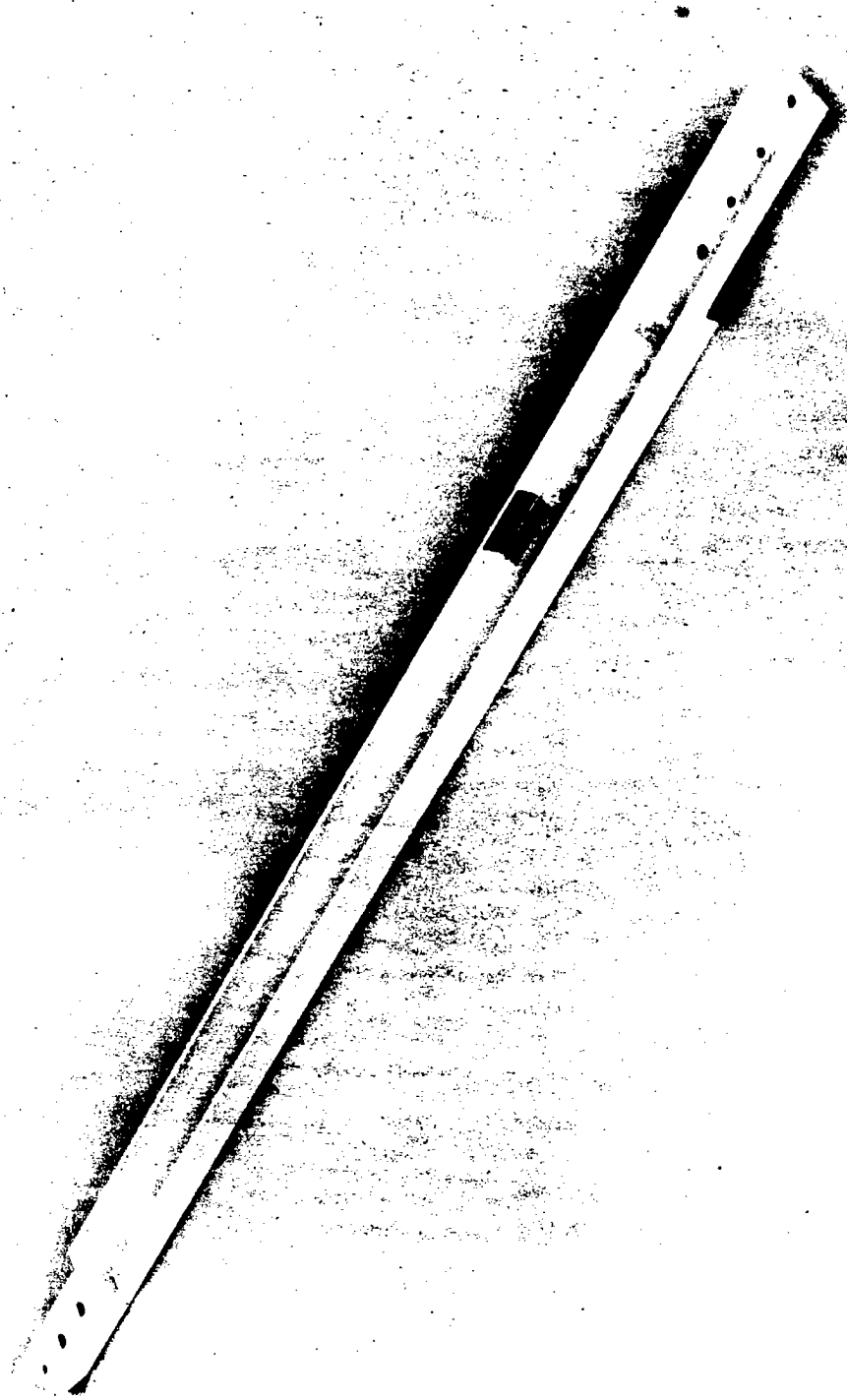

Fig.9 - Particulate reinforced Floor Beam Strut

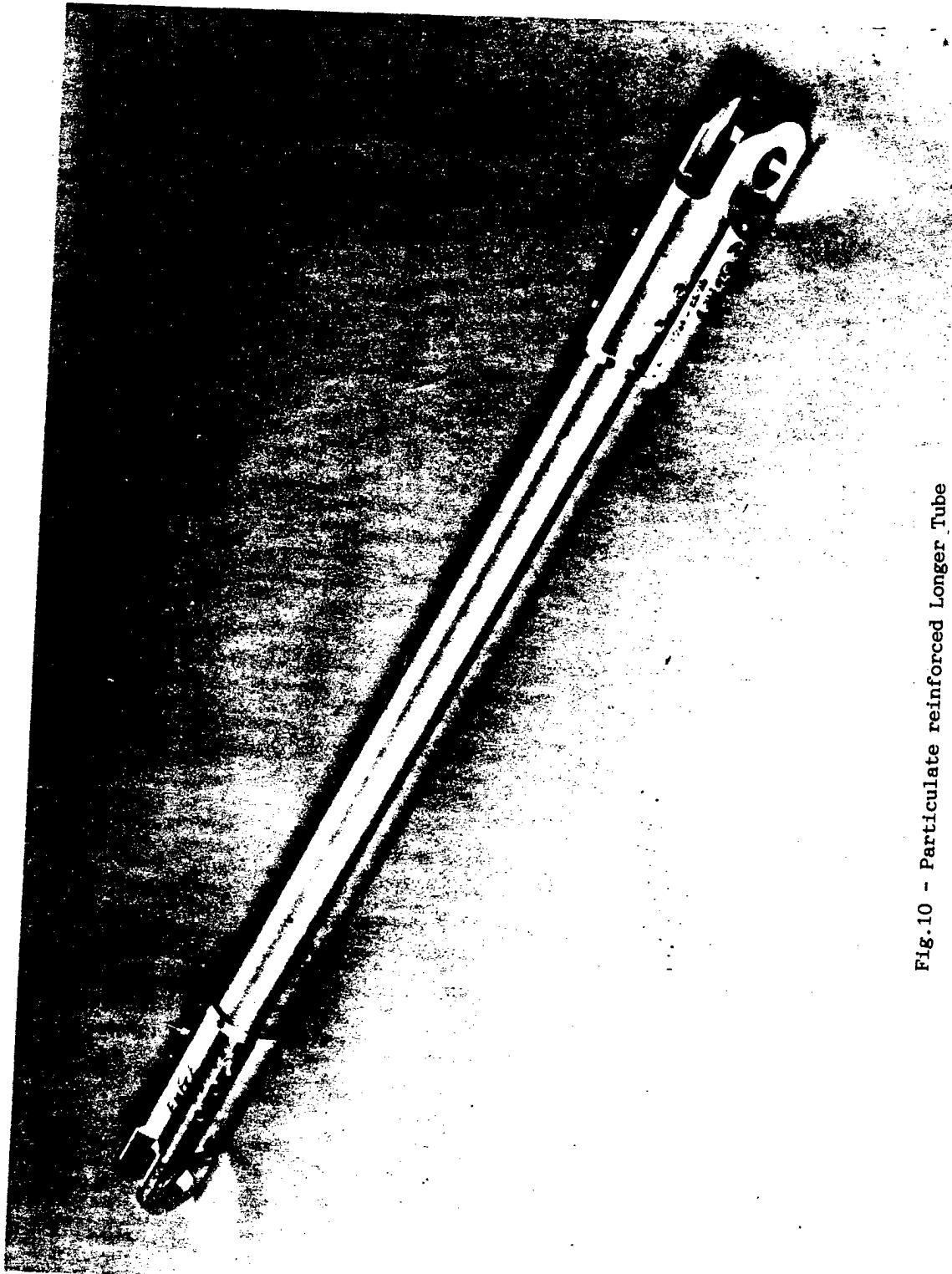

Fig.10 - Particulate reinforced Longer Tube

Superplastic forming of aluminium alloys for structural and non-structural applications for the aerospace industry

by Mr B J Dunwoody,
Technology & Development Manager,
and Mr R J Stracey,
Product Development Manager, Superform Metals Limited

SYNOPSIS Superform Metals Limited has been producing superplastically formed aluminium alloy components for the aerospace industry for fifteen years. Manufacturing methods used and components produced will be described. Techniques for forming standard alloys and fibre reinforced thermoplastics using a sacrificial sheet of superplastic aluminium as a diaphragm will be described. Production of parts for structural applications from 7475 SPF and Alcan LITAL 8090 SPF alloys using Back Pressure Forming will also be described.

1 INTRODUCTION

Although the phenomenon of superplasticity in metals has been known for over sixty years, it is only in the last fifteen years that superplastic alloys have been exploited commercially. This commercial exploitation continues to grow mainly in specialised markets and especially in the aerospace industry. However, some superplastic aluminium alloys have found wider application in other areas such as medical, communications, architectural, transportation and electronics.

Superform Metals in Worcester has been manufacturing aluminium alloy components for all the above markets since 1973. Superform USA was set up in 1986 and produces aluminium alloy SPF components and fibre reinforced thermoplastic components, almost exclusively for the aerospace market in the US. Until recently, applications in the aerospace industry have been limited to semi- or non-structural parts, manufactured mainly in Supral 100/150 alloys.

The intention of this paper is to briefly describe the principles of superplastic forming (SPF) methods by which parts have been manufactured and the alloys used to produce these parts.

Methods will be described whereby higher strength structural alloys such as 2014, 2219 and 7475 may be formed using superplastic alloy sheet as a sacrificial diaphragm.

Many parts have been made by Superform in fibre reinforced thermoplastic using a further development of the diaphragm forming technique. Production methods using two diaphragms will be described.

There is now an increasing demand for superplastically formed, aluminium alloy Class I structural parts for aircraft, which must be of high integrity, with minimum cavitation. This is achieved by forming in a confining hydrostatic pressure environment known as back pressure forming (BPF). The most suitable alloys are 7475 SPF and Alcan LITAL 8090 SPF.

Production of parts from both these alloys will be described.

2 SUPERPLASTIC SHEET FORMING

There are a number of prerequisites for an alloy to display superplasticity at elevated temperatures.

A fine grain size is required (normally less than 20 microns) and this fine grain must remain stable at elevated temperatures during deformation.

Very high tensile ductility can be achieved in elevated temperature tensile tests when deformed at slow strain rates of less than 10^{-2} per second. Elongations greater than 1000 per cent are often achieved.

At elevated temperature, flow stress is much lower than in non-superplastic alloys and is very strain rate sensitive, increasing rapidly with increasing strain rate.

In order to maintain these conditions for superplastic forming of components, deformation takes place in specially designed presses. Figure 1 shows schematically the principles of female forming and male forming. In both cases a single tool is used avoiding the need for expensive matched die sets used in conventional room temperature forming of sheet.

The tool and sheet are maintained at the superplastic forming temperature during the complete forming cycle which may take from a few minutes to two hours depending on the complexity of the component and the alloy used. Components are formed by clamping the sheet in the pressure chamber and applying air pressure to stretch the sheet and force it into contact with the tool. In stretching, the metal thins in some areas more than others and different methods are used to minimise thinning and maintain local strain rates within the range required for superplastic flow.

3 SUPERPLASTIC ALUMINIUM ALLOYS

The range of aluminium alloy sheet available for superplastic forming is limited to a small number of alloys:

Supral 100 and 150 (2004)
5083 SPF
7475 SPF
8090 SPF

Typical room temperature properties are shown in Table 1.

Table 1 Typical room temperature properties of superplastic aluminium alloys

Superplastic Alloy	0.2% P.S. MPa	UTS MPa	El. %
2004 - 0	120	200	7
2004 - T6	300	420	5
5083 SPF - 0	150	300	20
7475 SPF - T5	285	420	15
7475 SPF - T73	480	530	8
8090 SPF - T6	370	450	6

4 MANUFACTURE OF COMPONENTS

Many hundreds of thousands of components have been produced in 2004 alloy as Supral 100 (unclad) and Supral 150 (clad on both sides with 8% nominal thickness of 99.7% purity aluminium).

Parts made in Supral 100 and 150 are suitable for non-structural and semi-structural use after heat treatment.

Many parts have been designed from the outset as superplastic formings, an example is shown in Figure 2. The Supral 100 components which are part of the fuel system in the British Aerospace Jetstream aircraft are formed on cast, one piece, aluminium tools. The port and starboard hand parts are formed together and then trimmed, each hand consisting of four pieces. Joining of the parts is effected by a combination of welding and joggles which enable the components to be assembled in the wing tanks to form part of the fuel pumping system.

Figure 3 shows the assembly method for the superplastically formed parts of the aileron hornbalance for the Fokker F50 commuter aircraft. Eight parts for each of the port and starboard wingtips are assembled using a combination of welding and rivetting.

Other parts have been made as one piece formings to directly replace assemblies of many rubber-pressed, drop-hammered and hand-finished components, improving accuracy and reproducibility and effecting improvements in interchangeability.

Supral parts have been used in many other applications for both civil and military use, such as ejection seats, air conditioning and oxygen supply boxes, air brake weather shields, fairings, nacelles, intakes, galley trolley panels, passenger service units and cockpit panels.

In addition, there are many applications outside the aerospace sector, including radar and communications reflectors, electronics cabinetry, specialist vehicle panels and medical equipment housings.

5083 SPF alloy may be formed using both the male and female forming presses. However only components with modest superplastic strains up to 100 per cent are achievable. Since the forming temperature for this alloy is in excess of 500°C it is necessary for the one piece tools to be made from ferrous materials. Recent developments have shown that it is possible to superplastically form interior fittings for the cabin of civil aircraft as a direct replacement for parts previously made in plastic. An example of such a demonstration part is shown in Figure 4. Outside the aerospace industry, 5083 SPF has found widespread use in architectural applications such as panels for cladding internal and external walls, decorative facades and suspended ceilings.

5 DIAPHRAGM FORMING

The need for medium and high strength structural alloy components for the aerospace industry has led to the development of the diaphragm forming technique (1) for standard alloys such as 2014, 2219, 7075 and 7475. Utilising a sacrificial sheet of superplastic aluminium alloy (usually Supral 100), a sheet of non-superplastic alloy may be pressed into a female tool or over a male tool. The diaphragm is clamped around its periphery in the press, but the component blank is free to move. Any tendency for buckling of the component is inhibited by the superplastic diaphragm. Alloys which are difficult to form at room temperature may be readily formed using this technique with similar one piece tooling to that used for superplastic forming. Only a small amount of strain is introduced during diaphragm forming, hence the finished components are close to uniform thickness. The shapes that can be formed are relatively simple with a low degree of double curvature. They are often 'tunnel' type shapes with little closing off at the ends, such as the example shown in Figure 5. A further example of a diaphragm formed component in 2219 alloy is shown in Figure 6.

The technique can also be used for forming superplastic materials where a shape is more demanding and a degree of thinning is acceptable, provided that the tendency of the blank to buckle can still be inhibited by the diaphragm.

6 DIAPHRAGM FORMING OF THERMOPLASTIC COMPOSITES

A collaborative programme between Superform Metals and ICI has resulted in the development of the diaphragm forming process into techniques for thermo-forming a range of composite materials (2). Work has focussed on forming components from APC (aromatic polymer composite), a material based on continuous carbon fibres in a polyetheretherketone (PEEK) matrix.

In the new technique, the APC is laid up between two sheets of superplastic aluminium. The resulting sandwich is placed into a

pre-heated superplastic forming press and the air is evacuated from between the diaphragms. The APC melts, and the hot sandwich is forced by air pressure either into a female tool or over a male tool to achieve the desired shape. The process is shown schematically in Figure 7. During this process, the diaphragms are stretched whilst the carbon fibres are drawn and draped into the final shape. The diaphragms provide support during forming, preventing buckling of the fibres and allowing them to slide relative to one another in the liquid matrix. A further advantage of diaphragm forming over other methods, e.g. autoclave moulding, is that the diaphragm supports the final shape, allowing the sandwich to be removed hot from the press and quickly cooled. Suitable release agents are used to facilitate removal of the aluminium. Numerous parts have already been made using this method of manufacture and an example is shown in Figure 8.

A further refinement of this process allows for the attachment of secondary features to formed parts. Because the PEEK matrix is molten during diaphragm forming, the process affords the possibility of joining secondary features without the use of adhesives. The individual elements of the final assembly are pre-shaped and consolidated before final joining is achieved using rigid cores to maintain shape. Pressure during the joining phase is maintained throughout by a compliant SUPRAL diaphragm.

7 BACK PRESSURE FORMING

During normal superplastic forming, most alloys develop small internal voids as strain increases. These voids, known as cavitation, may adversely affect the mechanical properties of formed and heat treated parts and its control becomes critical in structural aerospace applications. The acceptance by aircraft designers of the new structural SPF alloys, Alcan LITAL 8090 SPF in particular, depends upon reducing or eliminating cavitation. The tendency for cavities to form can be suppressed by forming in an appropriate confining hydrostatic pressure environment. The pressure is normally applied by means of an inert gas, e.g. argon or nitrogen, to both the front and back of the sheet being formed, with a relatively small pressure differential such that the sheet is forced against the tool surface. Not only does this procedure limit the formation of cavities, but it can also, for certain alloys, including 8090 SPF and 7475 SPF, significantly enhance formability. Figure 9 shows a component formed using back pressure.

8 HEAT TREATMENT OF COMPONENTS

Many superplastically formed components in Supral 100 / 150 have been supplied in the 'as formed' condition with no further heat treatment, for non-structural applications. Where higher strengths are required for semi-structured components, heat treatment of Supral, 7475 SPF and non SPF diaphragm formed alloys may be carried out. It is essential to prevent excessive distortion of components during solution heat treatment and subsequently on quenching. This is achieved by attaching components to purpose made restraining frameworks. Distortion on quenching

is further minimised by using suitable quench additives.

For alloys where superplastic forming takes place at the solution heat treatment temperature, it is possible to avoid distortion due to quenching, by forced air cooling immediately on removal of the formed component from the press.

This method has been used for components formed in 7475 SPF alloy (see Figure 5). Although 7475 SPF is quench rate sensitive, it is possible to achieve adequate (T5) properties, as shown in Table 1, by artificial ageing after cooling.

The advantage of 8090 SPF alloy is that it does not suffer from quench sensitivity to the same degree as 7475 SPF. Structural parts may be formed in 8090 SPF using back pressure forming, forced air cooled from the press and aged to give near maximum properties.

9 SUMMARY

With low cost/short lead time tooling and the ability to produce simple to complex three-dimensional shapes in sheet aluminium alloys, superplastic forming is now a well established, cost-effective process.

The range of alloys now available and forming techniques which have been developed give the design engineer extra degrees of freedom and are of particular interest to the value engineer.

Superform Metals has many years of experience producing a vast range of components from decorative trim to structural parts with engineering properties.

Diaphragm forming of fibre reinforced thermoplastics has real advantages for small batch production of components without the problems of long lay-up/autoclave cycles and difficult material storage.

10 REFERENCES

- (1) BARNES, A. J. and TRACEY R. J.,
UK Patent 8421634, 25 August 1984.
- (2) CATTANACH, J.B. and BARNES, A. J.,
UK Patent 8406869, 16 March 1984.

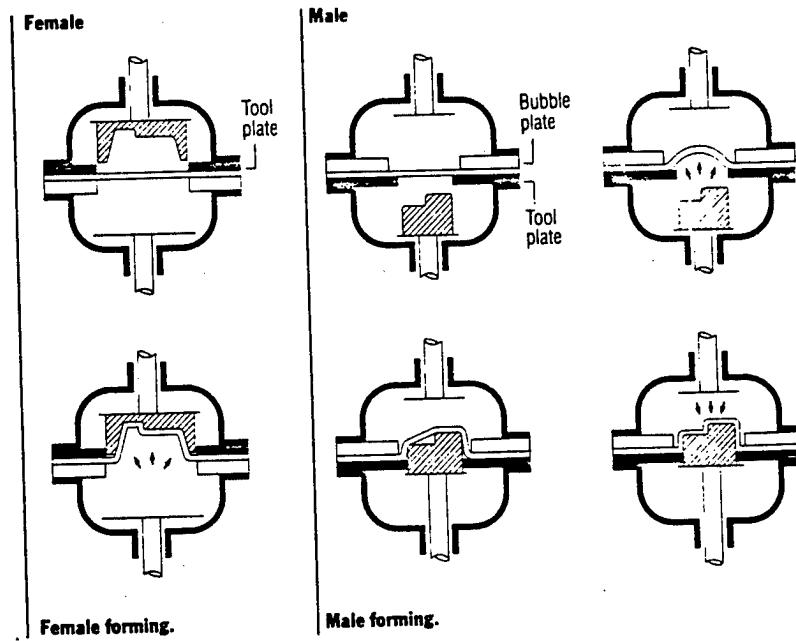

Fig 1 Techniques for forming superplastic aluminium sheet showing female and male processes

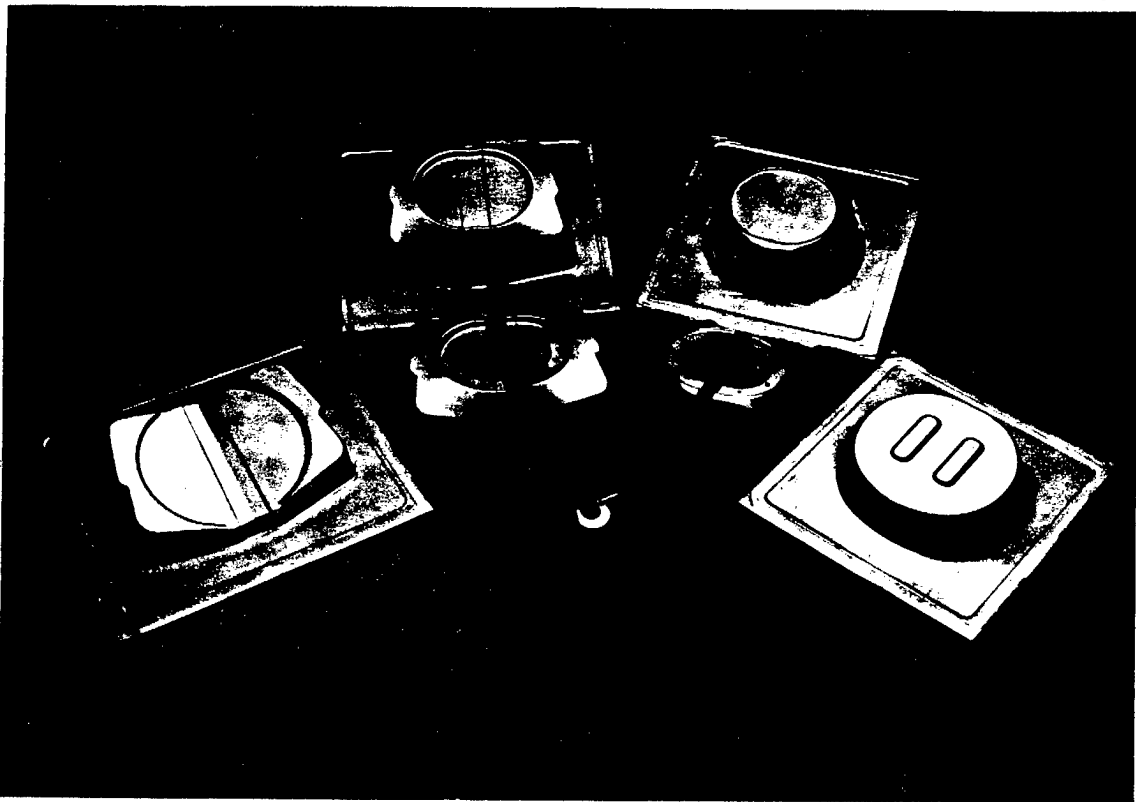

Fig 2 Formings and finished components for negative 'g' trays
for the British Aerospace Jetstream



Fig 3 Aileron hornbalance (wingtip) formed parts and finished
components for the Fokker F50 aircraft (formed in Supral
150 alloy)

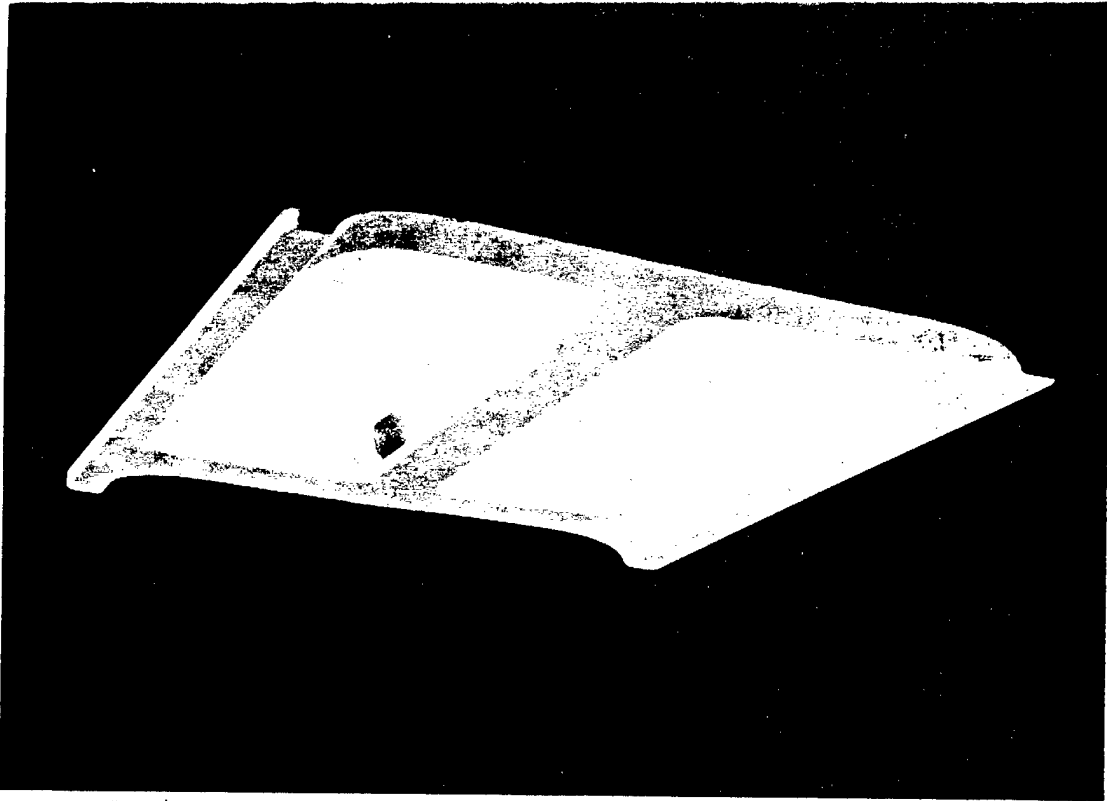

Fig 4 Overhead lighting panel for the cabin of a civil aircraft,
formed in 5083 SPF alloy

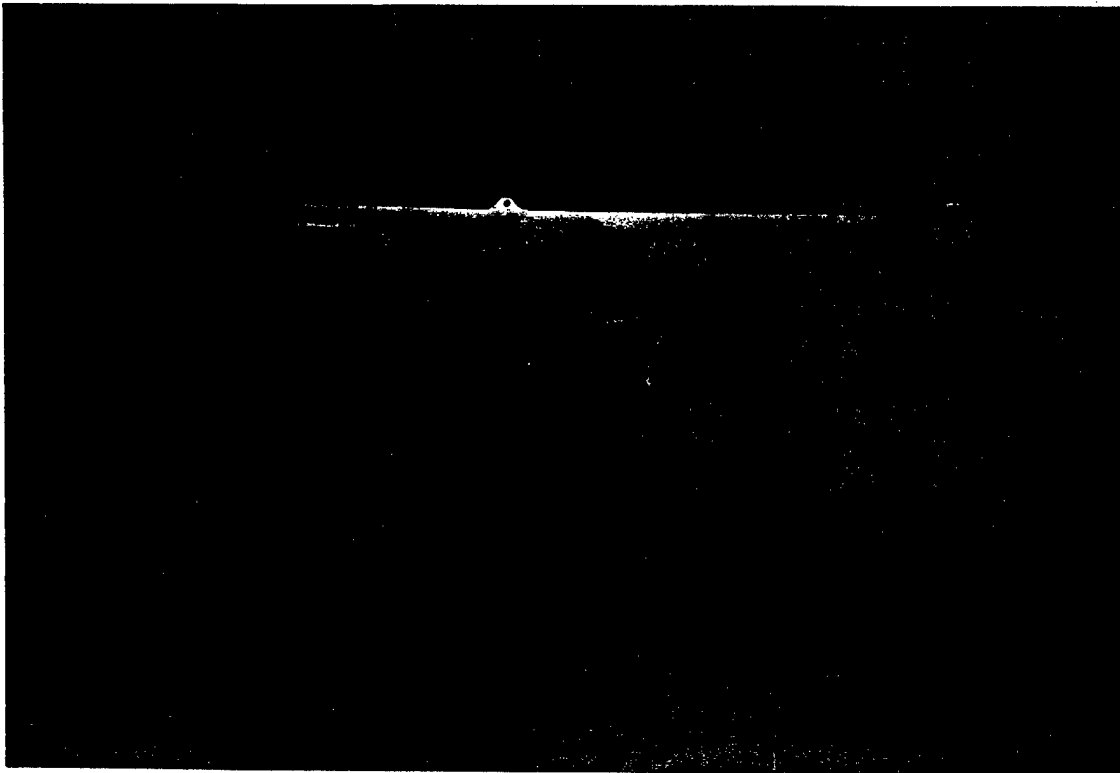

Fig 5 Gun pod fairing for the British Aerospace Harrier GR Mk 5,
diaphragm formed in 7475 SPF alloy



Fig 6 Aircraft engine intake, diaphragm formed in 2219 alloy

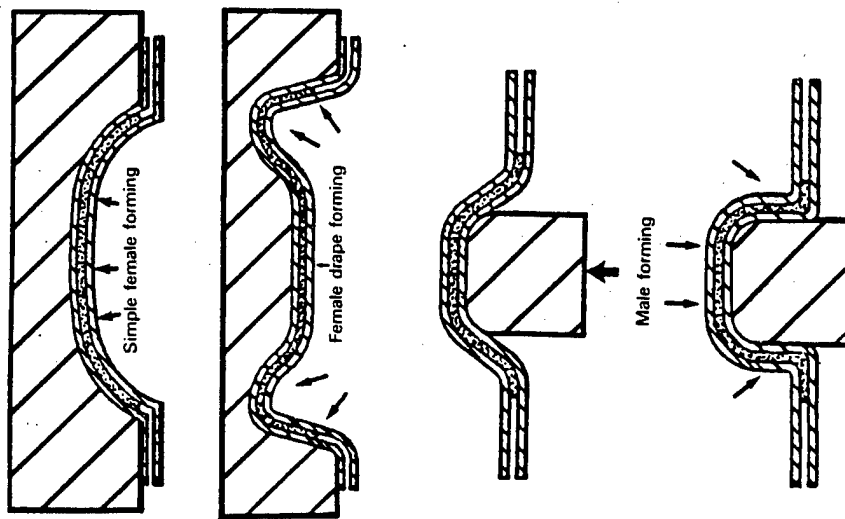

Fig 7 Forming of advanced thermoplastic composites using two Supral diaphragms

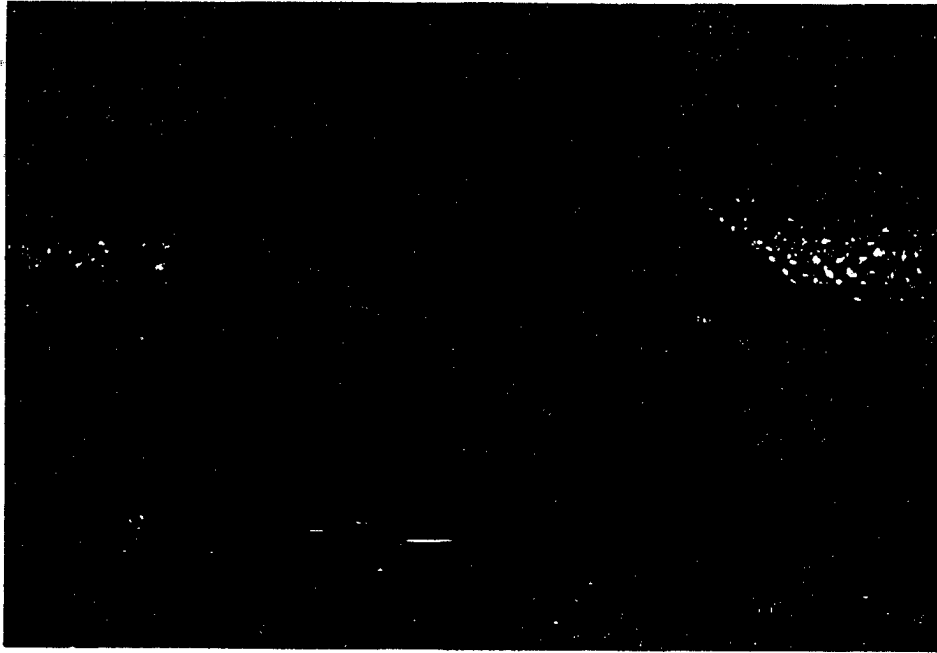

Fig 8 Pressure vessel end cap formed in ICI APC 2 (IM7)

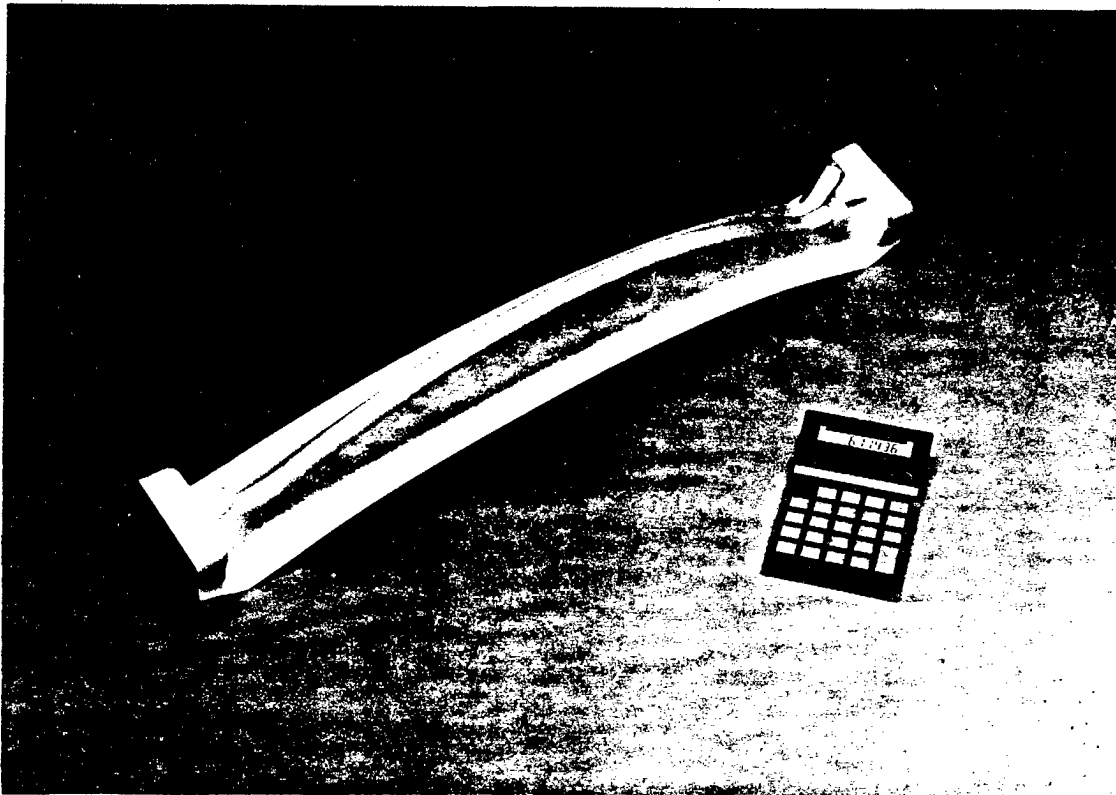

Fig 9 Sub-scale demonstration component superplastically formed under hydrostatic pressure conditions in 8090 SPF alloy (courtesy General Dynamics, Ft Worth)

Development of an SPF/DB Titanium Foreplane

by Mr S H Johnston,
Assistant Manufacturing Development Manager
British Aerospace (Military Aircraft) Ltd.

SYNOPSIS This paper presents an overview of the foreplane manufacturing development programme from initial panel elements through to manufacture of a foreplane representative in size and construction of that proposed for EFA.

1 INTRODUCTION

During the early 1970's British Aerospace at Filton established the basic principles of Superplastic forming / Diffusion bonding (SPF/DB). In the early 1980's BAe Military Aircraft Division set up a Study Group to assess the benefits of the emerging SPF/DB technology and as a result of the recommendations made, it was decided to set up a facility and develop SPF/DB as a production technology. The strategy for SPF/DB development covered the following areas:-

- (a) Basic material properties after SPF/DB.
- (b) Basic manufacturing process development.
- (c) Manufacture and test of structural elements representative of the various types of SPF/DB configurations.
- (d) Design, manufacture and test of a large class 1 demonstrator structure (foreplane).

The overall development plan is shown in Figure 1.

2 BASIC TECHNOLOGY

This covered basic research into the SPF/DB process and the effect of the SPF/DB process on the material properties of Ti.6Al.4V TA59 alloy.

2.1 Basic material properties

The aims of this programme were:-

- (a) To evaluate material properties after the SPF cycle and establish design allowables including the investigation of variation in processing parameters. This was achieved by the manufacture of a large number of test boxes with varying strains upto 200% as shown in Figure 2. These boxes were manufactured under a number of conditions using different forming temperatures, strain rates, pressure time cycles and cooling rates. Figure 3 summarises the effect of strain on mechanical properties.

- (b) To evaluate material properties and bond strengths after the SPF/DB cycle and establish design allowables, including the investigation of variation in processing parameters.

This work involved the definition of a pressure time curve for DB. This is shown in Figure 4. Once a basic PIC had been derived the effect of further variables on bond quality was determined. These covered, various types of staining, surface finish, recleaning of sheets, and bond temperature. From this work the datum DB parameters used for the foreplane manufacture were determined.

- (c) To evaluate basic NDT techniques for DB joints, including the definition of acceptance criteria for types and sizes of defects. To develop the NDT techniques necessary for determining bond quality, a number of DB specimens with known defects down to a size of 1/64" were manufactured. This enabled calibration of NDT equipment and establishment of minimum defect sizes detectable.

The results of this programme therefore provided the initial data base for the foreplane design and in conjunction with the basic manufacturing development programme provided data on the allowable processing window.

2.2 Basic manufacturing technology

This programme addressed the development of the hot open die SPF/DB process used in the manufacture of the foreplane. This covered the following areas:-

- . Diffusion bonding tooling development
- . Superplastic form tool development
- . Tooling materials
- . Development of stop off compound and application by silk screen printing
- . Development of SPF/DB processing techniques including gas management systems
- . Handling of large SPF/DB structures.

3 STRUCTURAL ELEMENTS PROGRAMME

3.1 Basic elements

The basic elements programme was aimed at the manufacture of a number of monolithic structural forms to determine both a Design and Manufacturing understanding of the forming of the SPF/DB structures. These panels were approximately 1M x 0.45M x 0.03M. Following an initial theoretical assessment two types of structural forms were investigated. These were termed:-

- (a) 3 sheet warren girder
- (b) 4 sheet X-core

These structures were used to establish both manufacturing expertise and design information. From a manufacturing aspect fundamental development and information was gained concerning the following:-

- (a) DB pack build up including manufacturing accuracy.
- (b) Silk screen printing of stop offs, process development and manufacturing tolerances.
- (c) Diffusion bonding techniques.
- (d) Superplastic forming techniques, ie. hot open die processing, contamination levels, hot loading/unloading.
- (e) Dimensional accuracy of SPF/DB components.

From a panel design aspect information concerning the parameters related to SPF/DB was obtained. This included the following data:-

- (a) Skin to core thickness ratios.
- (b) DB bond widths.
- (c) Core angles.
- (d) Thinning.
- (e) Sine wave cores, ie. amplitude, radius.
- (f) Straight web cores.
- (g) Cell gas management systems.

Figure 5 shows a section through a 4 sheet sine wave X-core panel.

From the above data the SPF/DB forming rules for producing panels of an acceptable standard were determined. Using this data a number of panels were designed and manufactured for static and fatigue testing. Figure 6 shows a static test panel. For the foreplane this data confirmed the optimum solution was a high angled four sheet straight core, wide skin to core bonded panel. The difference from the original concept to this final design is shown in Figure 7.

3.2 Advanced elements

Having established basic panel geometries a number of panel elements representative of specific features of the foreplane design were designed and manufactured. These advanced panel elements were used to investigate the following:-

- (a) Full foreplane root depth.
- (b) Core cut outs at foreplane root, trailing and leading edges.
- (c) Optimised skin thicknesses.
- (d) Step etched skins and cores.
- (e) Diffusion bonding of doublers at foreplane root.
- (f) Variable thickness flanges.

The objective of all these features was to achieve minimum weight and minimum cost.

3.3 NDT

In addition to the basic NDT work carried out through the basic technology programme, a further programme was carried out on a series of panel elements. The elements were designed with a series of known defects of various shapes and areas. These defects were created by selective no-bonding of diffusion bonded joints using stop offs. The type of defects created were:-

- (a) Core to core no bonds, both DB edge breaking and close to edge.
- (b) Skin to core bonds both DB edge breaking and close to edges.

The test panels were subjected to both C-scan and X-ray NDT. Figure 8 shows the stop off pattern for one of these panels.

4 FOREPLANE DEVELOPMENT

The development of the SPF/DB foreplane was carried out in parallel with the structural element programmes. In terms of manufacturing technology and design data, this was a interactive iterative learning process with information from elements being fed into the foreplane design and manufacturing process. The aims of the full size foreplane development programme were:-

- (a) To scale up the basic manufacturing process developed through the panel element programmes.
- (b) To develop the optimum design through a phased incorporation of design features of increasing complexity.
- (c) To manufacture full size foreplanes for structural test.

4.1 Basic manufacturing process

The basic manufacturing process utilised for the manufacture of the foreplane torsion box was the DB/SPF hot open die process.

4.1.1 Detail manufacture

The constituent sheets of Ti. 6Al. 4V alloy which are used to manufacture the foreplane are first prepared in the flat state. The material is cut to size and all relevant gas management holes, slots and tooling holes are drilled. Good accuracy of the tooling holes is essential to ensure the correct alignment of the multi-sheet stack and subsequent location in the SPF forming tool. Chemi-milling of the core and skin sheets is also carried out at the detail stage. The details are next 'super cleaned' using a HF/HNO₃ solution to prepare the sheet surfaces for diffusion bonding. Once this operation has been carried out the sheets must be handled in a clean room environment to prevent contamination of the super cleaned surfaces.

The next step in the detail manufacture is the application of a stop off compound to local areas of the super cleaned sheets. This compound is based on yttria and is applied by a

silk screen printing process. The stop off selectively prevents diffusion bonding. The stop off pattern is a function of the final formed structural configuration. A set of foreplane details printed with stop off (light areas) is shown in Figure 9.

4.1.2 Diffusion bonding

The next stage of the foreplane manufacture is diffusion bonding of the details. The major details ie. skins (2 off), cores (2 off), and doublers (2 off), see Figure 10, are assembled in the specified stacking sequence, placed in the diffusion bonding tool see Figure 11, and loaded into the hot platen press for diffusion bonding. This process is carried out at 925 C for 90 minutes by applying an argon gas pressure of 300 p.s.i. On completion of this process the diffusion bonded flat pack is removed from the DB tool and inspected using ultrasonics.

4.1.3. Superplastic forming

The flat bonded pack is superplastically formed using the hot open die process, ie. the cold flat pack is coated with release agent and loaded into the hot die at 900 C, the interspace (stop off coated areas) between the diffusion bonded cores and skins is pressurised using high purity argon gas causing the skins to blow out to fill the tool cavity taking up the CPL shape of the foreplane. Simultaneously the core sheets are strained to adopt the X-core configuration. This pressurisation is carried out under controlled conditions of strain rate at 1.5×10^{-4} sec⁻¹ to ensure the material does not overthin and tear. The foreplane is stripped from the hot die and cooled to room temperature. The superplastic forming tools are manufactured from special heat resistant 22Cr 4Ni 9Mo austenitic steel. Figure 12 shows the SPF dies which weigh approximately 4 tonnes.

Subsequent manufacturing operations involve the removal of alpha-case contamination from the surface of the skins by chemi-milling and profiling of the foreplane.

4.1.4 Quality control

Quality control is carried out at all stages of the foreplane manufacture. This involves the following stages:-

- (a) Inspection and checking of details.
- (b) Chart recorder print outs of the in press DB process. This includes time, temperature and pressures.
- (c) Extraction of metallographic test pieces to check DB quality.
- (d) NDT C-scan testing of the DB flat pack.
- (e) Chart recorder print out of the in press SPF process. This includes time, temperature and pressures.
- (f) Extraction of metallographic specimens to check the depth of alpha-case.
- (g) Hydrogen test pieces to monitor hydrogen pick up during the chemi-milling process.
- (h) X-ray of the formed structure, to check alignment of the core structure.
- (i) Dye penetrant crack detection of the formed component.

- (j) Dimensional inspection of the formed component.

5 FOREPLANE DESIGN

5.1 SPF/DB torsion box

The foreplane design has evolved as a result of manufacturing development trials on full size foreplanes and structural elements. This work addressed the SPF/DB process limitations and design features for various SPF/DB structures, such as thinning, quilting (mark off of skins) and overall formability.

Early trade studies showed that a four sheet SPF/DB design offered more scope for weight saving than a three sheet design. However at that time the design was being driven by what could be produced within the boundaries of existing manufacturing knowledge. As a result of a finite element analysis and increased manufacturing know-how a optimum weight configuration for the foreplane X-core geometry was derived.

The main features of the advanced foreplane demonstrator SPF/DB design were:-

- (a) Four sheet X-core configuration with 60 web angles and 80mm skin to core bond widths.
- (b) Multi step etched skins varying from 3.65mm at the root to 0.5mm at the tip.
- (c) Multi step etched cores varying from 3.00mm at the root to 0.5mm at the tip.
- (d) Diffusion bonded doublers at the root.
- (e) Local core cut outs at the root and leading edge for weight reduction.
- (f) Tapered landings (tool grip areas).

These features were proven on the demonstrator foreplane in order to enable a minimum weight EFA design. Figure 13 shows a demonstrator SPF/DB foreplane with cut out to expose structure.

The mass of the SPF/DB foreplane torsion box was marginally heavier than the CFC torsion box, however when the attachment of a spigot was taken into account the SPF/DB foreplane with bolted spigot showed an overall weight reduction compared with CFC, and a SPF/DB foreplane with a diffusion bonded spigot showed a significant weight saving compared with CFC. A design to cost exercise also shows the SPF/DB foreplane was the most cost effective option.

5.2 Diffusion bonded spigot

The next phase of the foreplane programme is to develop the capability for diffusion bonding of the spigot to the torsion box. This involves the development of the basic manufacturing process and establishment of a design data base. Work has commenced on the manufacturing technique development using panel elements representative of the foreplane root. It is intended to develop the technology for the first EFA production foreplane.

6. CONCLUSIONS

In principle the concept of SPF/DB is very simple and basic structural forms can be manufactured with relative ease. However a foreplane is a very complex piece of structure

which is difficult to manufacture which ever technology is utilised. This has resulted in a considerable development programme which has been described in this paper and the success of which has culminated in the selection of SPF/DB for the manufacture of the EFA foreplane.

Looking to the future the next phase of development is the incorporation of a diffusion bonded spigot which will give further benefits in terms of cost and weight.

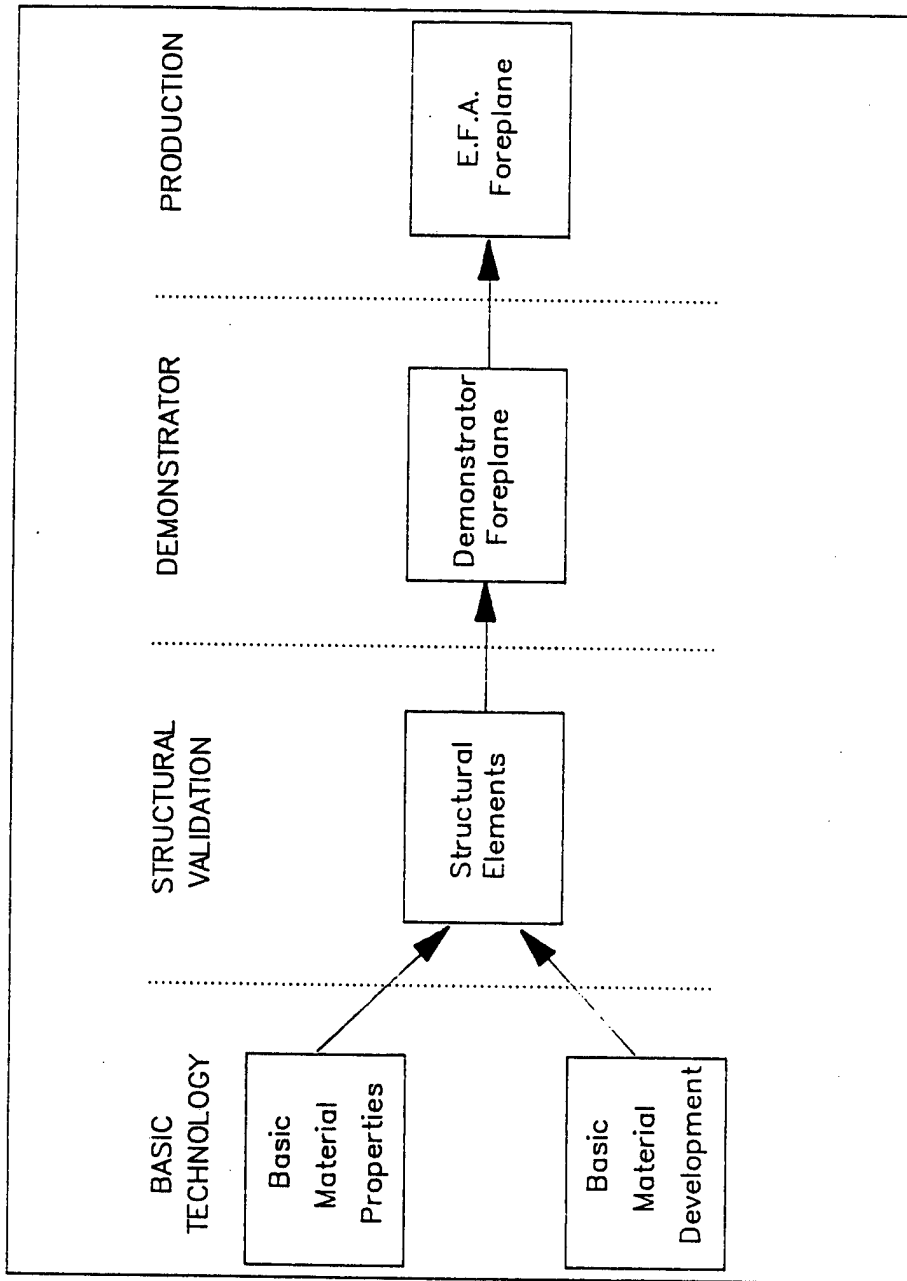

Fig 1 Overall demonstrator programme.

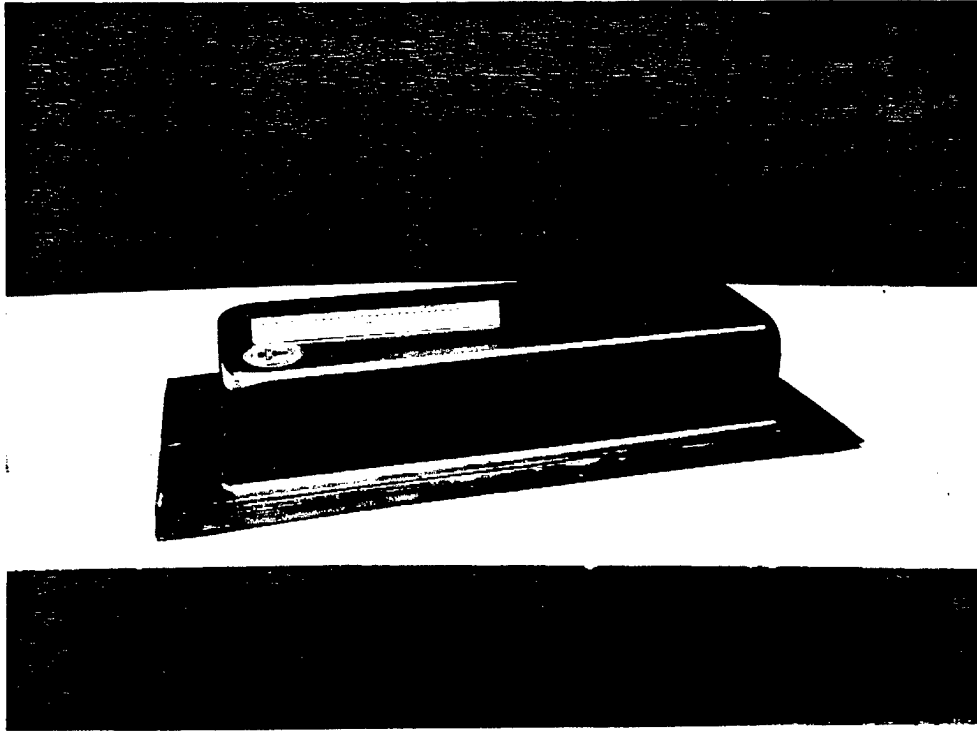

Fig 2 SPF properties box.

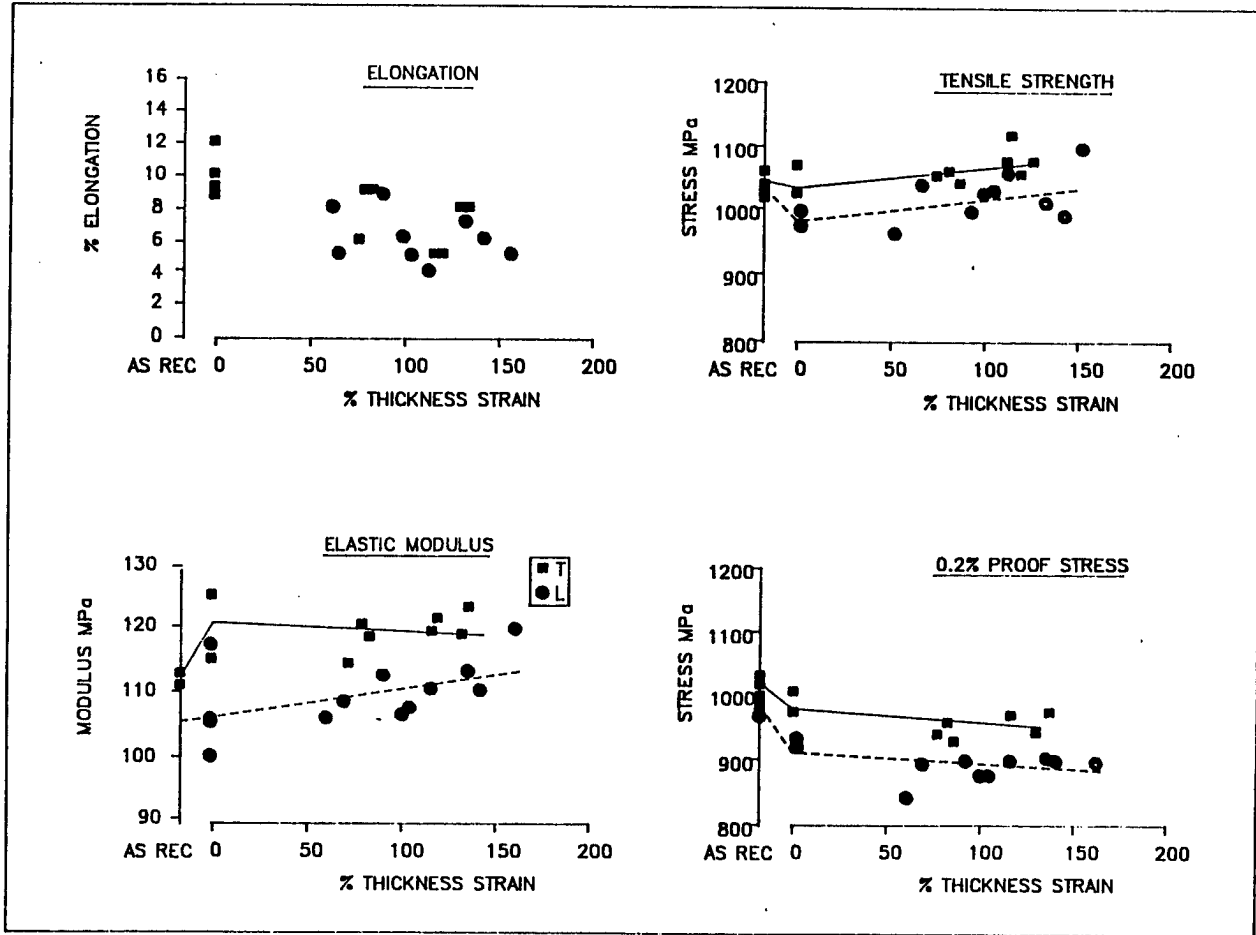

Fig 3 Effect of SPF strain on tensile properties.

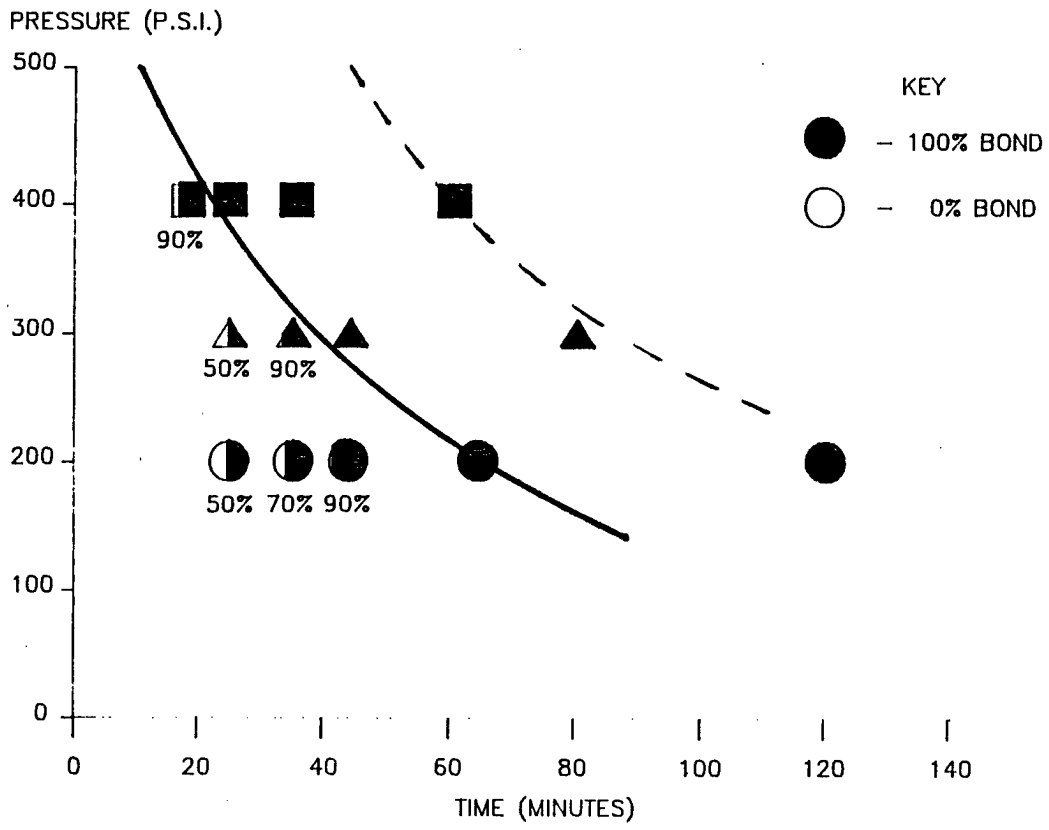

Fig 4 DB pressure time curve.

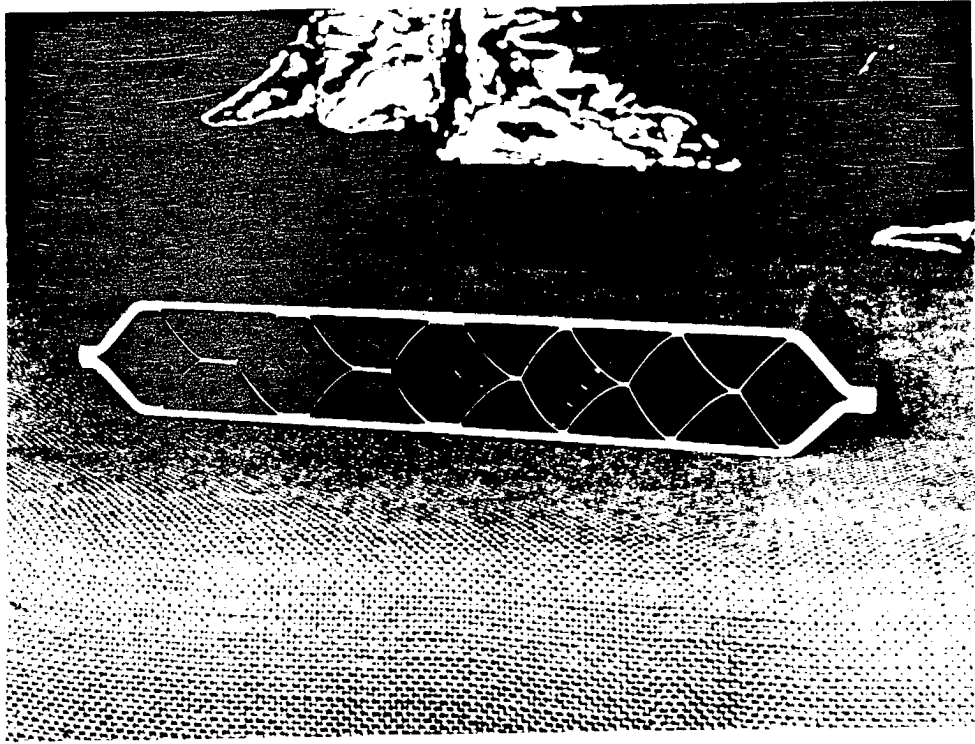

Fig 5 4 sheet sine wave X-core.

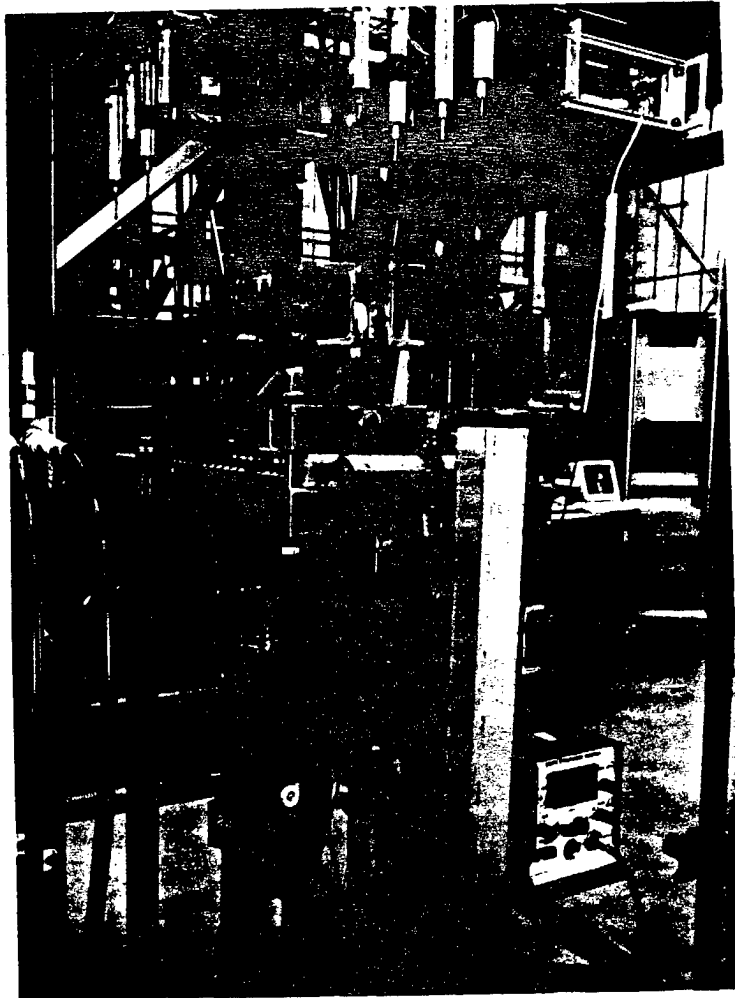

Fig 6 Static test panel.

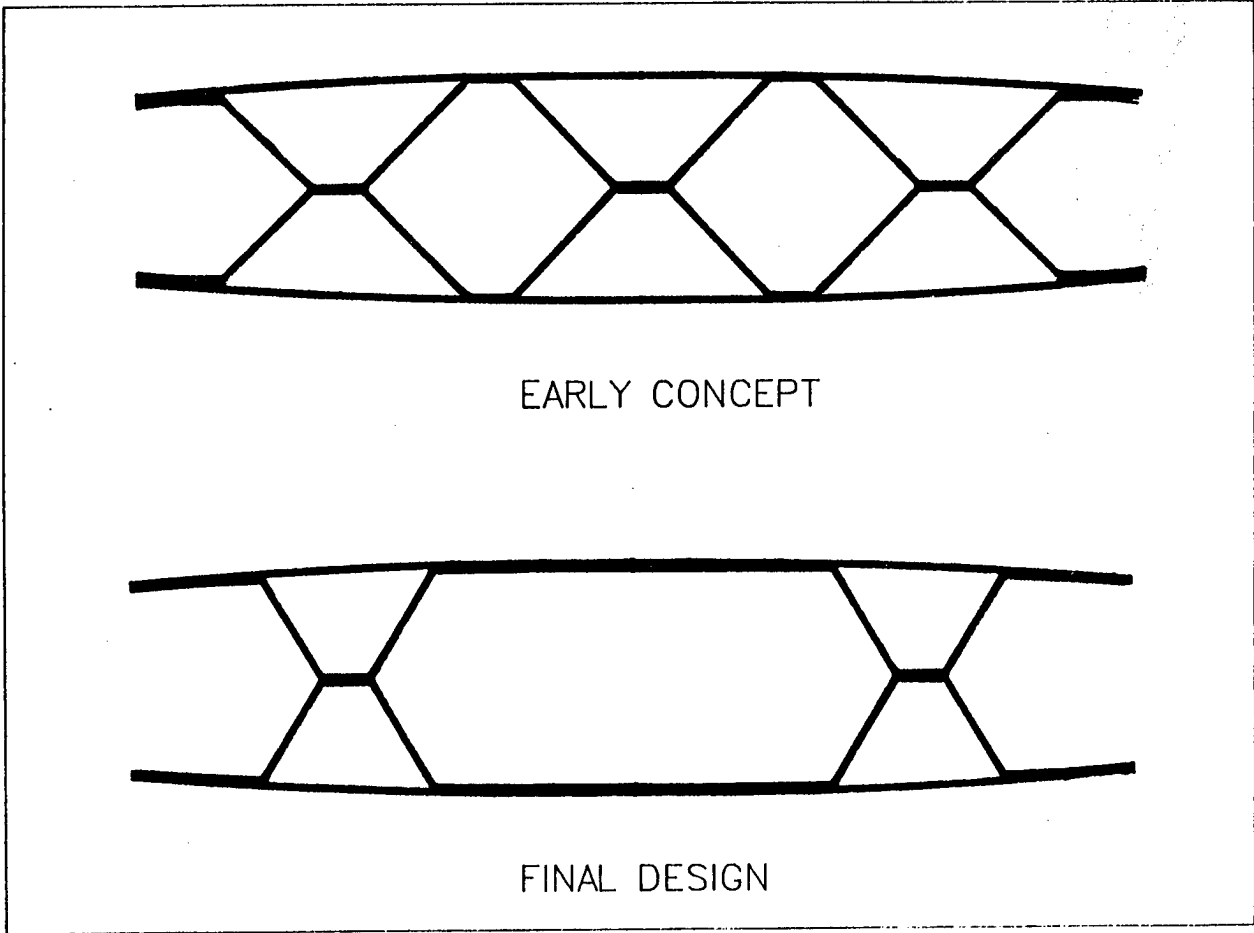

Fig 7 Comparison of foreplane core structures.

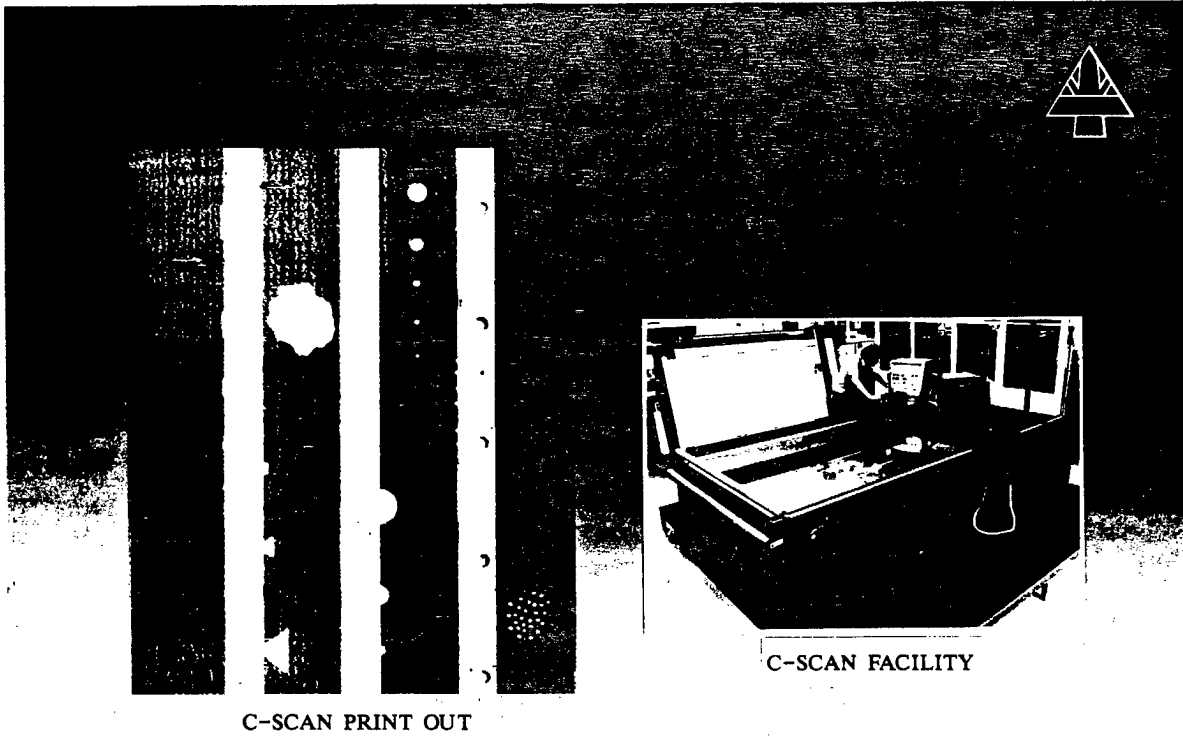

Fig 8 NDT test panel stop off pattern.

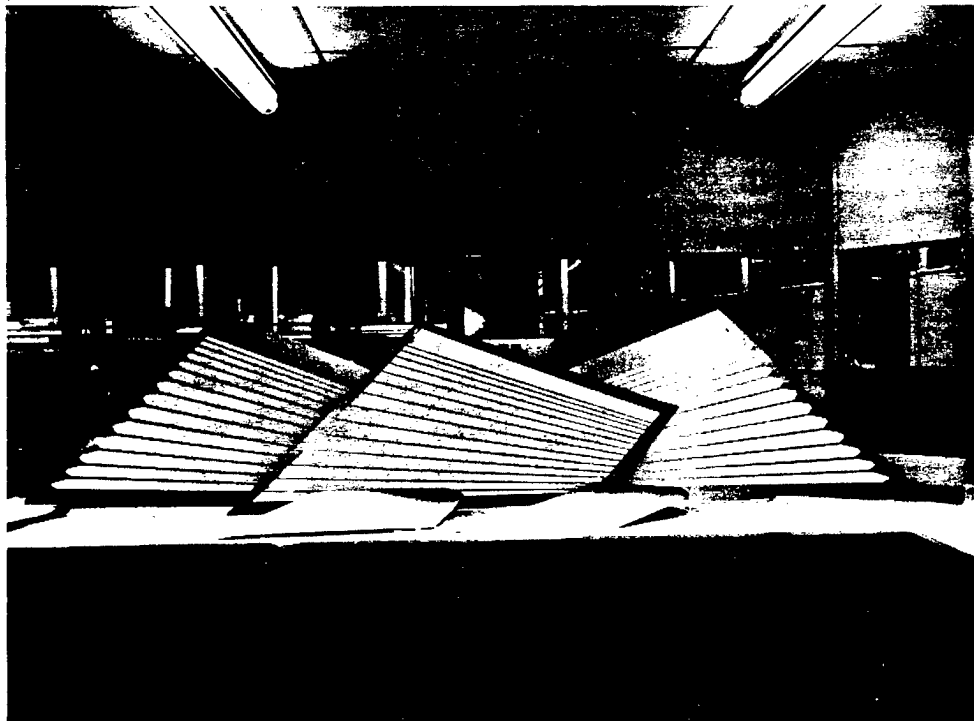

Fig 9 Foreplane details printed with stop off.

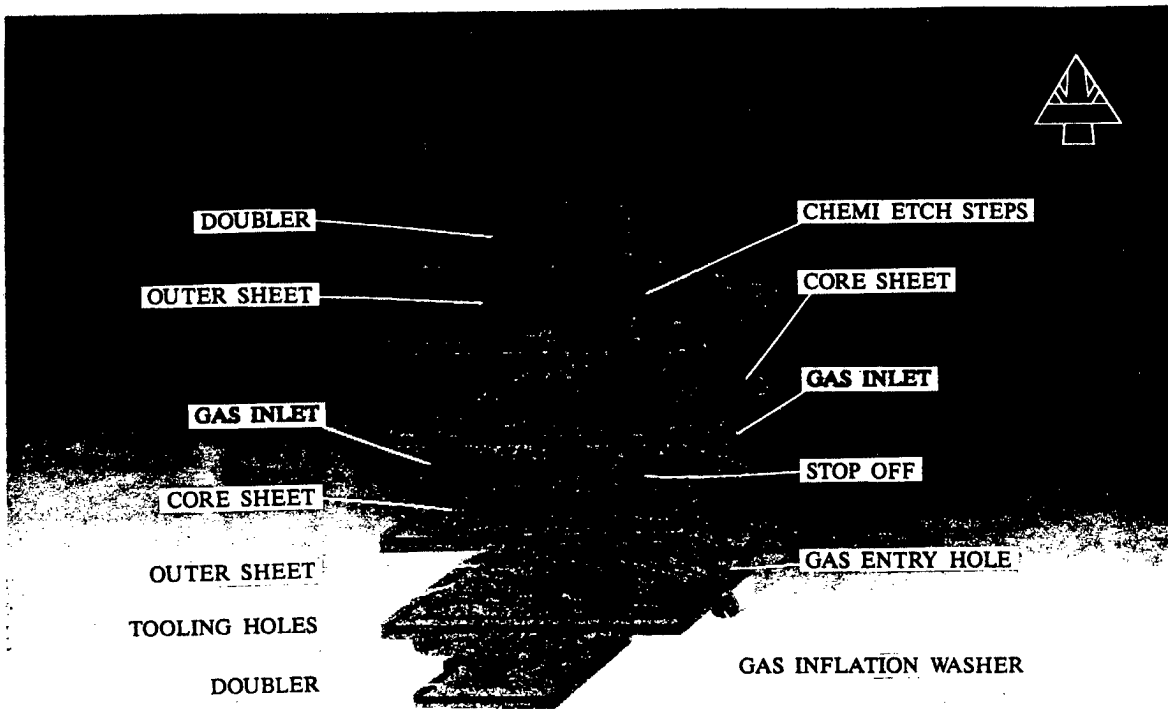

Fig 10 Foreplane flat pack assembly.

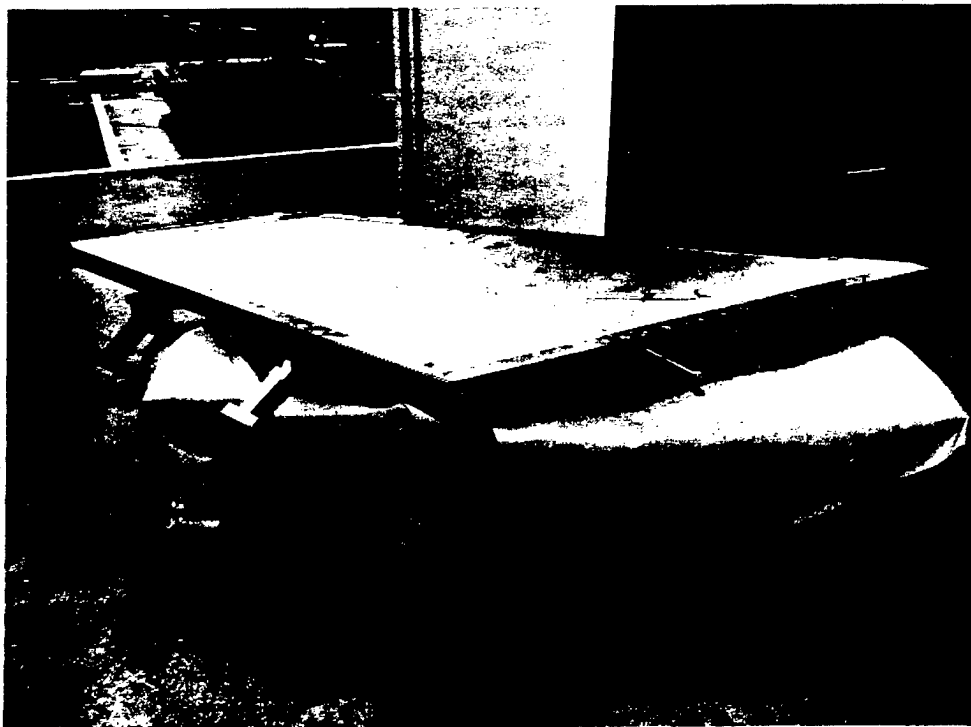

Fig 11 Diffusion bonding tool.

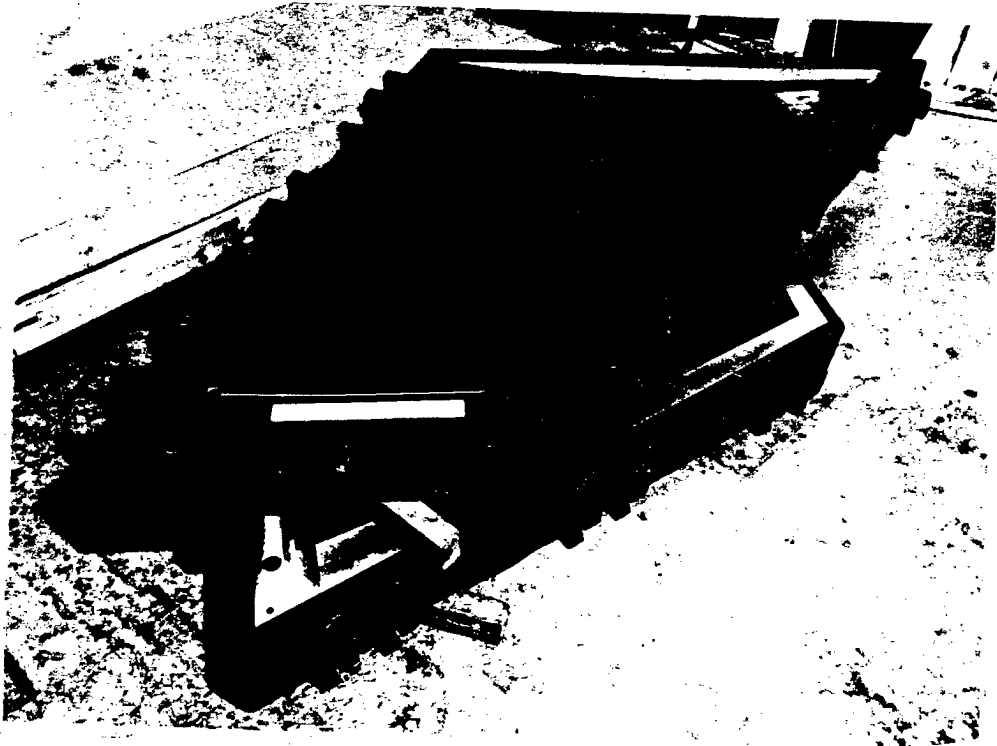

Fig 12 Superplastic form tool.

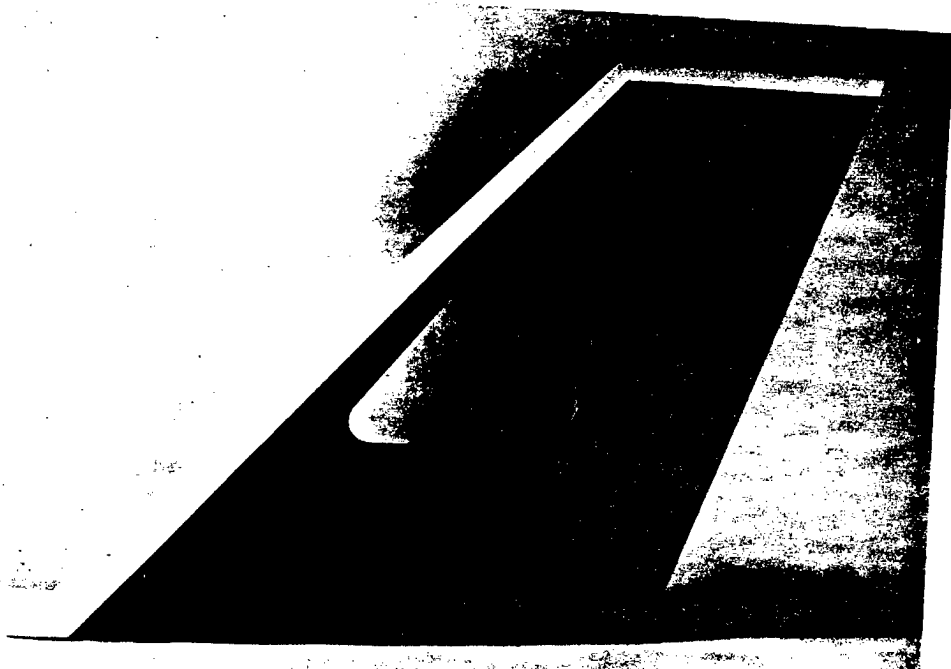

Fig 13 Demonstrator SPF/DB foreplane.

22161

9

NTIS

ATTN: PROCESS 103
5285 PORT ROYAL RD
SPRINGFIELD, VA

22161

This is a U.S. Government publication. Its contents in no way represent the policies, views, or attitudes of the U.S. Government. Users of this publication may cite FBIS or JPRS provided they do so in a manner clearly identifying them as the secondary source.

Foreign Broadcast Information Service (FBIS) and Joint Publications Research Service (JPRS) publications contain political, military, economic, environmental, and sociological news, commentary, and other information, as well as scientific and technical data and reports. All information has been obtained from foreign radio and television broadcasts, news agency transmissions, newspapers, books, and periodicals. Items generally are processed from the first or best available sources. It should not be inferred that they have been disseminated only in the medium, in the language, or to the area indicated. Items from foreign language sources are translated; those from English-language sources are transcribed. Except for excluding certain diacritics, FBIS renders personal and place-names in accordance with the romanization systems approved for U.S. Government publications by the U.S. Board of Geographic Names.

Headlines, editorial reports, and material enclosed in brackets [] are supplied by FBIS/JPRS. Processing indicators such as [Text] or [Excerpts] in the first line of each item indicate how the information was processed from the original. Unfamiliar names rendered phonetically are enclosed in parentheses. Words or names preceded by a question mark and enclosed in parentheses were not clear from the original source but have been supplied as appropriate to the context. Other unattributed parenthetical notes within the body of an item originate with the source. Times within items are as given by the source. Passages in boldface or italics are as published.

SUBSCRIPTION/PROCUREMENT INFORMATION

The FBIS DAILY REPORT contains current news and information and is published Monday through Friday in eight volumes: China, East Europe, Soviet Union, East Asia, Near East & South Asia, Sub-Saharan Africa, Latin America, and West Europe. Supplements to the DAILY REPORTs may also be available periodically and will be distributed to regular DAILY REPORT subscribers. JPRS publications, which include approximately 50 regional, worldwide, and topical reports, generally contain less time-sensitive information and are published periodically.

Current DAILY REPORTs and JPRS publications are listed in *Government Reports Announcements* issued semimonthly by the National Technical Information Service (NTIS), 5285 Port Royal Road, Springfield, Virginia 22161 and the *Monthly Catalog of U.S. Government Publications* issued by the Superintendent of Documents, U.S. Government Printing Office, Washington, D.C. 20402.

The public may subscribe to either hardcover or microfiche versions of the DAILY REPORTs and JPRS publications through NTIS at the above address or by calling (703) 487-4630. Subscription rates will be

provided by NTIS upon request. Subscriptions are available outside the United States from NTIS or appointed foreign dealers. New subscribers should expect a 30-day delay in receipt of the first issue.

U.S. Government offices may obtain subscriptions to the DAILY REPORTs or JPRS publications (hardcover or microfiche) at no charge through their sponsoring organizations. For additional information or assistance, call FBIS, (202) 338-6735, or write to P.O. Box 2604, Washington, D.C. 20013. Department of Defense consumers are required to submit requests through appropriate command validation channels to DIA, RTS-2C, Washington, D.C. 20301. (Telephone: (202) 373-3771, Autovon: 243-3771.)

Back issues or single copies of the DAILY REPORTs and JPRS publications are not available. Both the DAILY REPORTs and the JPRS publications are on file for public reference at the Library of Congress and at many Federal Depository Libraries. Reference copies may also be seen at many public and university libraries throughout the United States.