

JPRS-EST-90-024
21 DECEMBER 1990

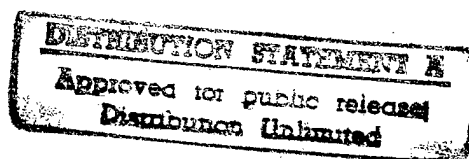

**FOREIGN
BROADCAST
INFORMATION
SERVICE**

JPRS Report



Science & Technology

***Europe
Economic Competitiveness***

DTIC QUALITY INSPECTED 3

REPRODUCED BY
U.S. DEPARTMENT OF COMMERCE
NATIONAL TECHNICAL INFORMATION SERVICE
SPRINGFIELD, VA. 22161

19980123 082

Science & Technology

Europe

Economic Competitiveness

JPRS-EST-90-024

CONTENTS

21 December 1990

WEST EUROPE

SCIENCE & TECHNOLOGY POLICY

EUREKA Chairman Interviewed on Program Status [J.H. Andriessen Interview; Brussels EUREKA NEWS, 19 Sep 90]	1
1990 EUREKA Projects Reviewed [Brussels EUREKA NEWS, 19 Sep 90]	2
EC Competitive Civil Aviation Strategy Discussed [Stephane Sberro; Ohain AVIANEWS INTERNATIONAL, Oct 90]	8
Esprit II Program Interim Report Released [Bonn TECHNOLOGIE-NACHRICHTEN MANAGEMENT-INFORMATIONEN, 26 Sep 90]	10
France: 1991 R&D Budget Published [Paris AFP SCIENCES, 20 Sep 90]	10
France: LETI Transfers BICMOS Technology to SGS-Thomson [G. Girault; Paris ELECTRONIQUE ACTUALITES, 5 Oct]	12
French Atomic Energy Agency To License Electron Accelerator [R. Font; Paris ELECTRONIQUE ACTUALITES, 12 Oct]	13
Unification Creates Many Problems for German Patent Offices [Egon Schmidt; Duesseldorf VDI NACHRICHTEN, 12 Oct 90]	13
Italy: European Research Agency Established [Milan ITALIA OGGI, 15-16 Sep 90]	15
Italy: Milan Research Consortium's Laboratories Described [Milan FATTI E NOTIZIE, 3 Sep 90]	15
Italy: Activities of City Research Consortia Described [Beppe Croce; Milan LITO, Oct 90]	16
Netherlands: Economics Ministry Announces Technology Policy [Amsterdam COMPUTABLE, 14 Sep 90]	22
Dutch 1991 Research Budget Discussed [Rijswijk POLYTECHNISCH WEEKBLAD, 20 Sep 90]	23

CORPORATE ALLIANCES

JESSI Approves Joint European Wafer-Scale Memory Project [Berlin MIKROPROZESSORTECHNIK, Oct 90]	24
Alliance Between Fiat, France's CGE Detailed [Rome AIR PRESS, 10 Oct 90]	24

CORPORATE STRATEGIES

Leading German Machine Tool Manufacturer To Offer CIM Components [Coburg MASCHINE & WERKZEUG, No 21, Oct 90]	25
Philips Announces Reorganization Measures	26
Further Job Cuts [Rotterdam NRC HANDELSBLAD, 25 Oct 90]	26
'Operation Centurion' Launched [Dick Wittenberg; Rotterdam NRC HANDELSBLAD, 30 Oct 90]	27
Principles of 'Operation Centurion' [Rotterdam NRC HANDELSBLAD, 30 Oct 90]	27

EAST-WEST RELATIONS

British-Hungarian Joint Venture's Expansion Plans Described [Zsuzsa Szekeres; Budapest NEPSZABADSAG, 15 Oct 90]	29
Former GDR To Produce Siemens Computers [Berlin MIKROPROZESSORTECHNIK, Oct 90]	30

SCIENCE & TECHNOLOGY POLICY

EUREKA Chairman Interviewed on Program Status

91AN0004 Brussels EUREKA NEWS in English
19 Sep 90 pp 4-5

[Interview with J.H. Andriessen, Dutch minister of economic affairs: "Minister Andriessen (NL), New Chairman of EUREKA: 'It's Time To Look At Where We Are'"]

[Text] This year the EUREKA [European Research Coordinating Agency] Chairmanship falls to the Netherlands. At the Rome Ministerial Conference (1 June 1990), J.H. Andriessen, Dutch minister of economic affairs, presented the Dutch work plan for its chairmanship year. This work plan is based on the Medium-Term Plan adopted at the Ministerial Conference in Vienna. Its main focus includes an assessment of EUREKA. In the following interview, Minister Andriessen gives further explanations.

EUREKA NEWS: Minister Andriessen, you were appointed Minister of Economic Affairs in September 1989, and began working with EUREKA immediately. What is your opinion of EUREKA?

Andriessen: In my view EUREKA is extremely important as far as developing an infrastructure is concerned. By this, I do not mean a physical infrastructure, but the development of a network linking companies and institutions, a technological infrastructure in which the exchange of technological know-how can develop at European level. EUREKA is contributing to the formation of the internal market. And European unification is of great importance for Europe's competitive position.

EUREKA NEWS: The Rome Ministerial Conference was the first EUREKA conference which you attended. Looking back on this conference, what are your feelings?

Andriessen: Well, one is always a bit afraid of any new experience, especially when you are Chairman into the bargain. But it is good for all countries to come together and to give EUREKA an impetus. I outlined the areas in which we were going to work during our chairmanship year, and the plan was enthusiastically received.

EUREKA NEWS: The Netherlands have an extensive work plan. The agenda includes an assessment of EUREKA. What is the objective of this?

Andriessen: EUREKA will soon have been in existence for five years. In my view, after this period of time it makes sense to look where we are with respect to the goals set in Hanover in the Declaration of Principles. For example, to what extent has EUREKA's principal goal—the strengthening of Europe's competitive position—been accomplished. In this respect, we are not so much evaluating as establishing where we are at.

EUREKA NEWS: Who will be carrying out this assessment?

Andriessen: It will be carried out by a small international team of managers from industry and science. As the Netherlands are now chairing EUREKA, the Chairman of the assessment panel is also a Dutchman, Prof. Dr. Wisse Dekker. The team started work on June 26 and will report to me at the beginning of 1991.

EUREKA NEWS: What do you think that this report will show?

Andriessen: By way of preparation for this assessment, we have asked a number of participants from the business and scientific world what they think of EUREKA. What we heard was that they considered EUREKA important in terms of the network which is developing, and of the unification of the European market, but there were also criticisms. So we will be working on improving EUREKA further. The assessment panel will probably arrive at a series of recommendations on how EUREKA can be further strengthened.

EUREKA NEWS: Other items of the work plan are the HDTV (high-definition television), JESSI (Joint European Submicron Silicon Initiative), COSINE (Corporation for OSI Networking in Europe) and PROMETHEUS (Program for European Traffic With Highest Efficiency and Unprecedented Safety) projects. Why is particular attention being paid to these projects?

Andriessen: We will be looking at these projects because we believe that they are of strategic importance to Europe. Each one of them is important for European industry and, when any one of them reaches the production stage, will involve a whole series of business sectors. Moreover, HDTV is just beautiful. Once you have seen HDTV pictures you are spellbound. They make present-day television look very makeshift. But I would emphasize that a lot must be done by the authorities in the area of supportive measures before we can all enjoy these razor-sharp pictures. Which is why we want to bring these projects to the attention of all EUREKA bodies: the Ministerial Conference, the High-Level Group and the National Project Coordinators (NPC). I want to foster discussions on the progress of these projects and on other activities which may be required to stimulate progress.

EUREKA NEWS: But will you also be looking at other projects?

Andriessen: The intention is that the NPC meetings will go through the whole project portfolio. This will give us an insight into exactly what is happening in the projects, so that we can see where there is room for improvement, particularly, with regard to procedures. Naturally, there are, and always will be, projects that fail, and which do not provide any new products or services. This is a fact of life in high-value technology and one you have to accept. But looking closely at all projects and studying progress may well provide some new ways of supervising

them, and preventing some of them from falling by the wayside. We can see if something is perhaps lacking in particular technological areas, or if something additional can be done. But of course our potential contribution is small; enterprises must come up with the projects themselves.

EUREKA NEWS: Eastern Europe is currently the centre of attention. Will Eastern European countries also be involved in EUREKA, and will they be able to join EUREKA next year?

Andriessen: During our Chairmanship, we shall be attempting to involve Eastern European countries more closely with EUREKA. Membership of these countries is not on the short-term agenda, but we shall be preparing for it. This means establishing criteria for full membership. Under certain conditions, this it is already possible, and will remain so, for individual companies and institutions to participate in projects. The necessary agreements were made back in Madrid in 1987.

We are naturally very interested to know how industry views cooperation with Eastern Europe. We want to find out their experience with Eastern European companies and the need for and possibilities of cooperation, to enable us to see the role which EUREKA can play in all this. Which is why we will be holding a seminar this year to stimulate the exchange of information between countries, enterprises and research institutes. This seminar will be open to participants from Eastern Europe. In this way we also hope to provide them with an insight into what EUREKA can offer.

EUREKA NEWS: Next year special attention will be given to environmental technology. Why this area of technology?

Andriessen: Yes, the environment now merits our particular concern. Environmental problems involve all European countries and must be tackled jointly. We have outlined a couple of areas in which new project proposals are desirable. One is called "Prepare" (Preventive Environmental Protection Approaches in Europe), the other "Ecodesign." "Prepare" is a proposal for demonstration projects in the environment-auditing area, whilst "Ecodesign" is aimed at achieving a better exchange of information on research into environmentally-friendly products. In this area too, we are attempting to get a number of demonstration projects moving. The idea behind these two initiatives is the need for every enterprise to become "waste-conscious." Indeed, the mastery of waste is an important aspect of modern-day production.

EUREKA NEWS: Next year EUREKA will be five years old. How will this be celebrated?

Andriessen: However we celebrate it, it will be celebrated properly. There are all sorts of ideas, but everything is still under discussion.

EUREKA NEWS: A final question. How do you see the future of EUREKA?

Andriessen: I am positive towards EUREKA's future. In Rome, I also noted great enthusiasm from different countries. The number of projects and the number of enterprises and institutes can still grow considerably. Of course, good technological infrastructure costs money, but it is extremely important for Europe's position on world markets. What we really need on top of this is a know-how based infrastructure and a similar initiative in the teaching area. In the Netherlands we are busy setting up a centre of excellence, a sort of graduate school. I could imagine that, at a certain point in time, we will be looking at setting up something similar at European level.

1990 EUREKA Projects Reviewed

91AN0005 Brussels EUREKA NEWS in English 19 Sep 90 pp 8-13

[Article: "General Overview of the New Projects Announced at the 1990 Rome Conference"]

[Text] On the following pages, there is a brief description of projects announced this year in the various EUREKA [European Research Coordinating Agency] technology sectors. Given the number and variety of projects, this overview cannot be exhaustive and can only constitute a "summary introduction," presenting the main directions of research and development topics on which work is going ahead.

For readers who would like to know more, we have provided a complete list of identification numbers of new projects in the box at the end of each sector. Using this key, the reader can obtain further information from the EUREKA database, which can be consulted on-line.

Medical Technologies and Biotechnology

This sector ranks third by number of projects after robotics and the environment. The new projects announced in Rome represent an increase of some 15

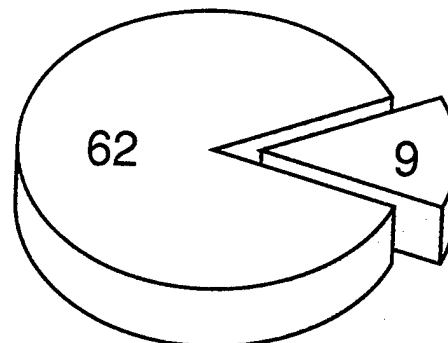

Total number of ongoing projects: 62, of which announced in Rome: 9

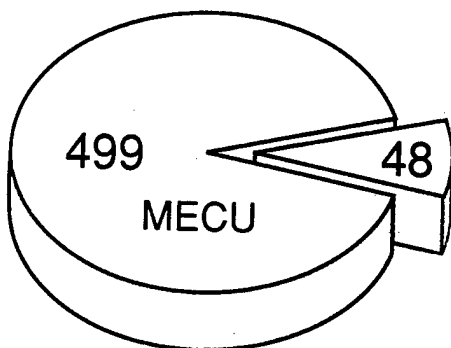

Total cost of ongoing projects: 499 million European Currency Units [ECU], of which announced in Rome: ECU48 million

percent. We can make a basic distinction here between projects involving human health and those in the agro-food sector.

Medical and Pharmaceutical Projects

The largest project in terms of cost—ECU21.4 million—is called “IMRI” (EU 431). It involves magnetic resonance medical imaging in medical diagnostics, a technology for which demand is continuously rising in modern medicine. This Nordic partnership (Norway, Finland and Sweden) aims both to improve the quality and reduce the price of this currently very expensive apparatus.

Another project is looking into the development of another type of imaging based on digital radiology.

Finally, a third project is aiming to develop new methods of diagnosing cervical cancer, the second most frequently observed form of cancer in women in industrialised countries.

In the pharmaceutical area, we should mention three projects:

- The first aims to develop neurotransmitters for use in the pathology of the brain and the central nervous system.
- A second project is directed towards producing a calcium antagonist for the treatment of coronary and cardio-vascular diseases.
- And a third deals with a variety of molecules which may be able to eliminate “free radicals” in tissue pathology.

Projects in the Agro-Food Area

Three new projects have been announced in this area, relating to:

- Industrial-scale micro-propagation of artichoke plants which are resistant to the traditional diseases which affect this crop;

- The creation of a pilot milk acidification unit, which will permit the development of a new series of original byproducts;
- The production of high value polysaccharides from marine algae biomass.

Communications

In this sector, four new projects, with a forecast overall investment of ECU67 million, were launched this year.

The most important in financial terms—with an announced cost of ECU41 million—is the TFTS (Terrestrial Flight Telephone Service, EU 443). This Anglo-French initiative aims to offer air travellers a long-awaited technology: the extension of mobile telephony to regular commercial airline flights. It is interesting to note that among the project partners are the national air transport and telecommunications companies from two countries which are playing a key role in the project.

Two other projects also combine both aviation and telephony:

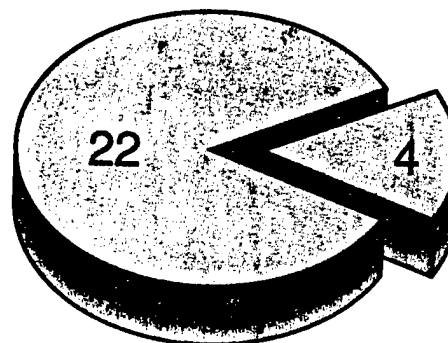

Total number of ongoing projects: 22, of which announced in Rome: 4

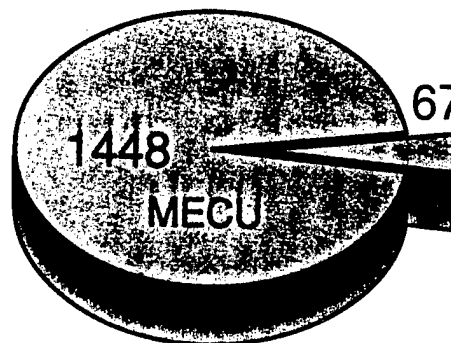

Total cost of ongoing projects: ECU1,448 million, of which announced in Rome: ECU67 million

- The first is the creation of a research "club" to resolve problems of electromagnetic compatibility encountered by the aviation industry;
- The second aims to develop new technologies to optimise the quality of sound transmission by telephone.

Finally, the last project, also of considerable financial significance (ECU20 million), is targeted at producing a new technology for magnetic recording on hard disks.

Energy

In this sector, two new projects with a forecasted overall investment of ECU27 million have been launched this year.

Most of this amount—ECU25 million—represents the cost of the "Jumbo Coking Reactor" project (EU 500). This cooperation brings together Austrian, Finnish, Italian, Spanish, and British partners, headed by the German steel manufacturer Ruhrkohle AG. It has been formed with the intention of developing a new coke combustion system for steel production, offering major energy savings in this energy intensive sector, at the same

time as reducing the substantial environmental damage caused by present-day coking plants.

The second project (EU 502) involves the development of small off-shore oil extraction units. These will make possible simple, low-cost exploitation of small underwater reserves which have so far been untapped because of their low extraction return.

Environment

Two fifths of the new projects announced in Rome relate to the environment. This year's harvest, which bears witness to the record growth of interest in this sector in the industrial and research worlds, doubles the total number of EUREKA projects in this area. This increase is to a large extent due to the success of the three large "umbrella projects"—Euromar (EU 37), Euroenviron (EU330), and Eurocare (EU140). These three projects aim to develop products and methods of securing a good knowledge of environment problems and of curing and preventing the effects of pollution. Euromar is concentrating on helping the seas around Europe, Euroenviron the land itself, and Eurocare the cultural heritage which this continent houses. A new group of projects has also been launched under the new common label of Envinet.

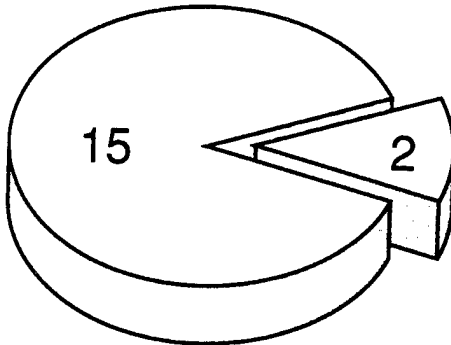

Total number of ongoing projects: 15, of which announced in Rome: 2

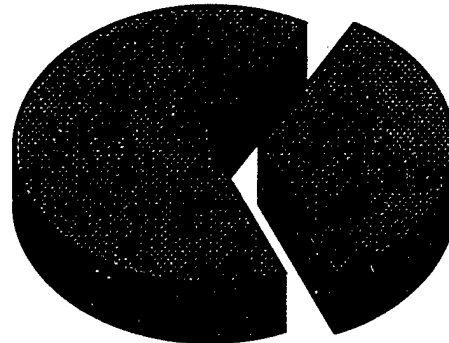

Total number of ongoing projects: 69, of which announced in Rome: 38

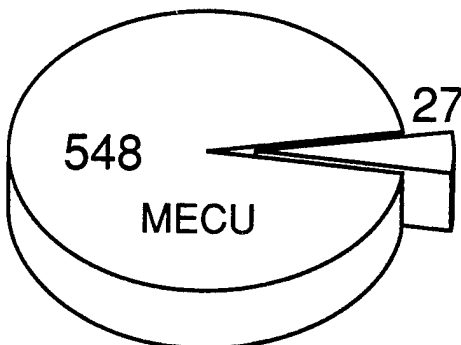

Total cost of ongoing projects: ECU548 million, of which announced in Rome: ECU27 million

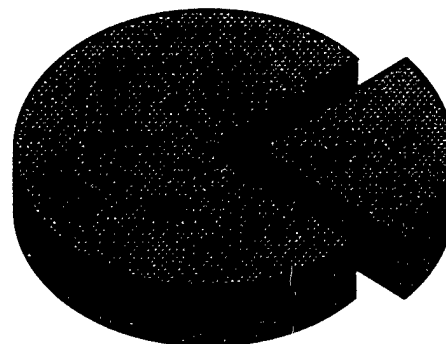

Total cost of ongoing projects: ECU877 million, of which announced in Rome: ECU254 million

Projects Under the Euromar Banner

This "family" of seven projects has grown by a further eleven at a total cost of almost ECU157 million.

Two projects stand out by the size of forecasted investment—ECU54 million and ECU49 million respectively:

- Firstly, Euromar-Seawatch (EU 453), an initiative formed by Norwegian, German and Italian participants to develop a vast experimental interactive surveillance network using sea beacons positioned in the various seas surrounding Europe;
- Followed by Euromar-Seastars (EU 494), a project uniting Dutch, German, and Italian partners, aimed at designing a complete control system, this time from the air, using remote sensing from surveillance aircraft.

The other Euromar projects involve:

- The creation of various forms of detection apparatus, sensing devices, measuring systems, etc.
- And the development of operating models for monitoring and protecting the marine environment.

The "Euroenviron" Project Family Takes Off

Set up in 1989 to create projects in land environment technologies (just one project saw the light of day last year), the Euroenviron umbrella project is now entering into its active phase with an initial group of seven new projects for a forecasted investment of almost ECU41 million.

The new technological applications include:

- waste water treatment;
- decontamination of soils and ground water;
- non-polluting incineration and environmentally responsible disposal of solid ferrous and non-ferrous waste;
- the recovery of waste plastics from scrapped cars;
- the drastic reduction of solvent emissions from dry cleaning processes;
- monitoring and emergency management technologies to counteract the emission of dangerous substances into the atmosphere.

A New Series of Eurocare Projects

Ten new projects have been added to the existing six projects under the Eurocare umbrella project, which aims to protect our cultural and architectural heritage against pollution. Of these new projects, representing an overall cost of almost ECU6 million.

- Four concentrate on processes for the protection and restoration of paintings.
- Three are working towards the development of new forms of protection for artifacts made of granite, marble and wood.

- One project deals with the development of a new type of optical disk offering greater permanence and longevity which will meet the enormous needs for very long-term archiving (in particular for the preservation of cultural production).
- Another Norwegian-Swedish project aims to develop a totally new system of (transparent) "protective envelopes" for protecting particularly threatened historic buildings. As with many other Eurocare projects, this project has immense possibilities of being transferred to the building industry as, for example, a sort of insulating "greenhouse" around a village.
- An additional one aims to create a database with an integrated expert system which will constitute a sort of encyclopaedia of available protection technologies.

Creation of a New "Envinet" Project Group

On the initiative of various Italian firms and bodies, together with participants from a number of other countries, a new family of projects under the common Envinet label saw the light of day this year.

The first seven projects, costing a total ECU43 million, aim to develop fairly wide applications:

- Devices for remote measuring and for obtaining information on the hydrological environment;
- Systems for managing and controlling damage to forests and for detecting acid rain;
- Finally, various automated management, control, modelling and cartography tools specially adapted to environmental problems.

Information Technologies

Information technologies (IT) are no doubt one of the keys to the whole industrial and scientific development of Europe in the coming years and occupy pride of place in the family of EUREKA projects. In particular we note that, with almost ECU1.8 billion of forecasted investments, this area is well ahead of other sectors. A sizeable

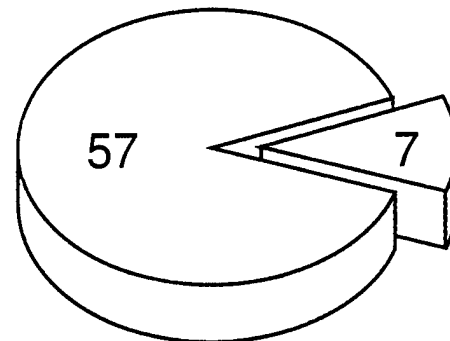

Total number of ongoing projects: 57, of which announced in Rome: 7

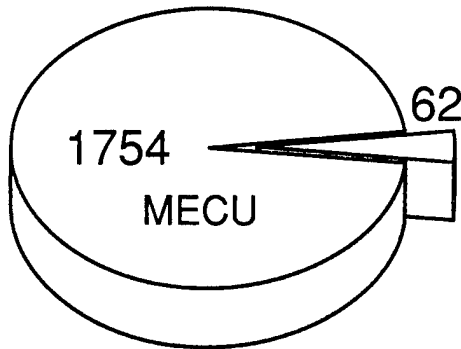

Total cost of ongoing projects: ECU1,754 million, of which announced in Rome: ECU62 million

portion of this amount—ECU550 million—represents commitments already undertaken in the launching stage of the JESSI project (EU 127), which constitutes a decisive step by European industry towards mastery of next generation semiconductors.

This year, seven new projects have been announced for an overall amount of ECU62 million. These include an initial category of projects relating primarily to the development of novel IT-based applications. Others are related more to improving the tools used in this area.

IT Application Projects

Heading this group in terms of financial size (ECU36 million), is the Genelex project (EU 524), launched jointly by French, Italian, and Spanish partners. Its objective is to develop machine-readable mono-lingual dictionaries to meet the needs of all informatics applications in the language-processing industry.

Two other projects to mention are working on:

- The development of an automated informatics tool for producing geographic maps, based in particular on data from remote-sensing imaging and using neuro-network architecture;
- The preparation of a CIM software system, specially adapted to a whole series of building-construction activities.

New Developments in Technological Tools

In this project category, we would highlight:

- The development of an entirely new approach in the area of multilayer semiconductor substrates (3-D) for hybrid integrated circuits;
- The development of a new concept of control screens for industrial automation systems;

- A project based on scanning acoustic microscopy technology, aimed at providing new and improved image analysis instrumentation, in particular for scientists specialising in surface and interface phenomena;
- Finally, the development of optical circuits and fibres for sensor systems.

New Materials

In this sector, five new products have been launched this year with an overall forecast investment of ECU36 million.

The most important in financial terms—with an announced cost of ECU20 million—is the Adept project (EU 442), which aims to revolutionise the traditional electrolysis process used in the production of aluminium. This collaboration between Italian, German, and Swedish partners aims to replace traditional carbon anodes with a new variety of ceramics which do not deteriorate during the electrolysis process. This would avoid environmentally unfriendly residues, and also opens the way to a remarkable saving of energy.

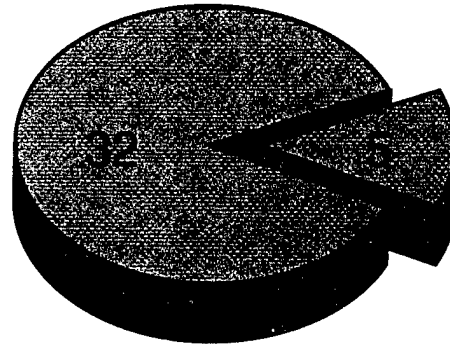

Total number of ongoing projects: 32, of which announced in Rome: 5

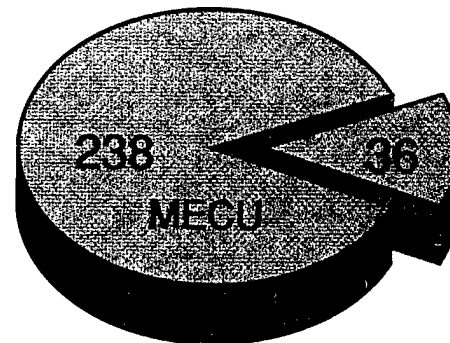

Total cost of ongoing projects: ECU238 million, of which announced in Rome: ECU36 million

The four projects are:

- A process for moulding reinforced AMCs (Aluminium Matrix Composites), used in the manufacturing of light weight, high-resistance components for the aviation and automobile industries as well as for sports articles;
- Development of a powder metallurgy process for steel with a high nitrogen concentration;
- The production of a waste water piping system from new forms of plastics;
- Improving the resistance of road infrastructures—in particular in developing countries—using a physico-chemical technique to consolidate locally sourced road construction materials.

Robotics and Production Automation

This sector already contained the largest number of EUREKA projects, a position maintained this year with the addition of 22 new projects—an increase of one third on the previous number. Forecast investment for these new projects is also considerable—a total of ECU264 million.

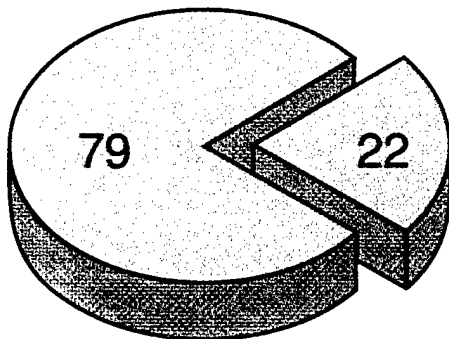

Total number of ongoing projects: 79, of which announced in Rome: 22

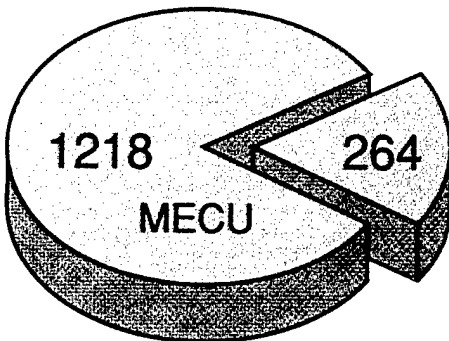

Total cost of ongoing projects: ECU1,218 million, of which announced in Rome: ECU264 million

Once again this year, EUREKA's activity in this area is due, for a large part, to the dynamism generated under "FAMOS." This umbrella project (EU 72) has succeeded in fostering a vast movement of industrial cooperation on the strategic topic of flexible automation of assembly and manufacturing process. Moreover, another group of projects, developed by a number of manufacturers which regularly supply the European market, is growing in strength under the banner of the Europari umbrella project (EU 261).

Maintaining the FAMOS Dynamism

The 26 projects already placed in orbit by the FAMOS programme have been joined by another 11 under this extremely active umbrella.

Overall investment announced this years in this group amounts to ECU100 million, including two projects of almost ECU25 million each:

- FAMOS-Euromach (EU 460), an Italo-Swiss project for creating a fully automated fibre and reinforced plastic production plant;
- FAMOS-Fysif (EU 531), a flexible integrated furniture manufacturing system applying CIM and "Just-in-time" technology, with partners from Italy, Norway, Finland, Austria, and Spain.

The other new FAMOS projects relate to process automation in very diversified activities: precision mechanics, boilermaking, production of miniature electromagnetic relays, the textiles sector, construction materials, and control and guidance devices.

Also worth noting is a project for automated storage handling, and another for creating an automated module for industrial fabrication of small and medium series, with interfacing between production and assembly.

Takeoff of Europari Projects

This year witnesses the takeoff of four initial projects under the Europari project umbrella. The goal: to develop the automation and robotisation of design and production processes in the aircraft industry.

These four projects, representing a total forecasted investment of ECU50 million, come from a core of five aircraft manufacturers with a major position of the European market: Air Italia (Italy), Fokker (Netherlands), Casa (Spain), Aerospatiale (France), and British Aerospace (UK).

Each project has its own very specific target: production of metallic aircraft parts (Europari-Spider), composite fibre materials (Europari-Ecras), electrical systems (Europari-Space), and finally special advanced CIM tools for aircraft construction (Europari-Eifas).

Other Projects in the Robotics/Production Automation Area

To conclude this sector, we should mention the important twin projects HPTV-SET and HPTV-DECK (EU 521 & 529). These projects aim to automate the manufacturing chain for video tape recorders. With an investment of ECU40 million each, the projects are coordinated by Philips Videowerk (Austria) with the participation of German and Dutch partners.

Five other projects, totalling ECU34 million, are directed at various developments:

- An automated ultra-sound system for inspecting pipeline networks from the inside;
- An advanced process for testing the effects of mechanical vibration;
- A new flexible electricity installation system;
- An entirely robotised cell for industrial machining;
- A automated bricklaying process for use on building sites.

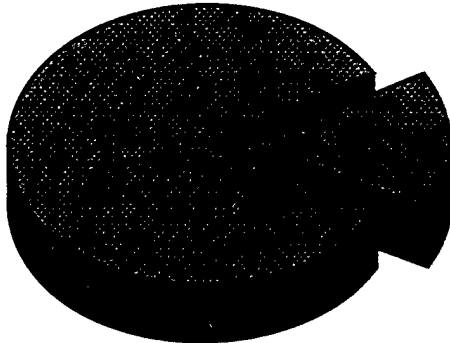

Total number of ongoing projects: 21, of which announced in Rome: 4

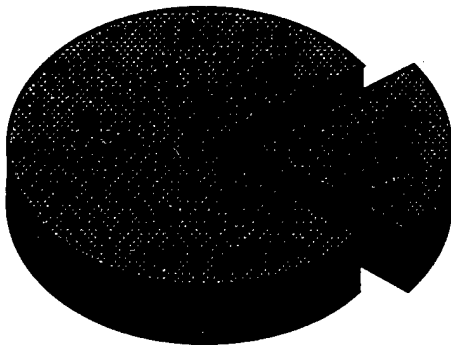

Total cost of ongoing projects: ECU750 million, of which announced in Rome: ECU191 million

Transport

The high level of investments—ECU191 million—announced this year in this sector is due mainly to a single project of exceptional size, which also holds the cost record for the 1990 harvest of projects. This is the “Elena” project (EU480), headed by the Italian Iveco-Fiat group in cooperation with three other partners, AVL (Austria), ZR (FRG), and Dereco (Zwitzerland).

The stakes are large: Elena aims to launch a new generation of complete engine sets with fully integrated electronic systems for the industrial vehicle sector. The ultimate goal is to offer the market engines with a very high degree of efficiency—due in particular to gearbox design—and with the lowest possible level of toxic exhausts.

The three other projects announced in the transport area are for:

- The development of a data logistical information and scheduling system to manage river transportation of bulk materials on the Rhine between the Ruhr and Rotterdam.
- The development of a complete (anti-)fire safety system, directed at the very specific requirements of fire prevention in road and rail tunnels.
- Work on a new type of expansion joint for high-speed continuous rails, offering passengers increased safety and comfort.

EC Competitive Civil Aviation Strategy Discussed

91AN0037 Ohain AVIANEWS INTERNATIONAL in English Oct 90 pp 44-45

[Article by Stephane Sberro: “The Aeronautics Industry: Towards a European Strategy”]

[Text] Industrial experts in the European Commission have just developed a strategy for the development of the aeronautics industry in the Community. Other than a rather positive assessment of the situation in the sector, Vice-President Bangemann’s department has put forward several proposals with a view to improving the competitiveness of European firms, which remains inferior to that of the United States. Industry ministers discussed this report at great length on September 21 last.

The Commission noted first of all that the European aeronautics industry plays an important role in building civil aircraft, controlling slightly less than 20 percent of the world market for commercial jet airliners. This sector employs some 500,000 people today and generated a trade surplus of nearly 6 billion European Currency Units [ECU] in 1987. The market is characterised by a limited number of manufacturers and a large number of clients, resulting in intense competition on selling prices and therefore the need for the industry to be competitive in terms of production costs. Furthermore, a fall in military spending due to the opening of East European borders will highlight the importance of civil construction even more. European industry suffers

a double handicap in relation to its American rivals in this context: Families of aircraft are developed less, which in other words clearly means that development costs are divided over a more limited range of aircraft and production of smaller series results in economies in the sector [as published]. The competitiveness of European firms, which is very often limited to their national territories, remains inferior to that of American firms. In its assessment of this situation, the Commission uses the notion of Direct Operation Costs (DOC). Although there is no single criterion to establish an aircraft's competitiveness, the general consensus is that the deciding factor is the DOC, which for an aircraft like the A320, for example, can be broken down as follows: approximately 40 percent for the purchase price of the aircraft; 20 percent for consumption; 20 percent for crew costs; 10 percent for maintenance; approximately 10 percent for miscellaneous costs. The cost of the aircraft is far from being the principal element of the DOC (40 percent) and half of this is linked to direct costs related to the production process (amortization of nonrecurrent costs and labour costs). Productivity is therefore a crucial element in the development of the aerospace industry.

Although wage costs are lower in Europe (and this is an important advantage), it is far from being sufficient to compensate for the important disadvantages on the level of production. Weaker European production and the short series which are manufactured (only Airbus can now manage to produce 500 examples) reduce the effect of the "apprenticeship curve." Apprenticeship here means the possibility of reducing the fixed development costs of a programme by using the design and various elements of an existing programme. This is where the interest of developing a family of aircraft and derived versions of an existing programme lies. An example of this is the Airbus family in Europe.

The advantage of wage costs has up until now not been enough to compensate for the European industries' lack of productivity in relation to its American rivals. The Commission has even drawn up a table describing the comparative situation between different EEC producer countries and the United States regarding the added value per worker in the aerospace industries (in thousands of ECUs):

Added Value per Worker in the Aerospace Industry

	1983	1984	1985	1986	1987
FRG	30	34	33	35	-
France	36	45	46	44	-
Italy	27	29	31	34	33
UK	24	24	25	29	-
U.S.	46	55	59	47	40

A Strategic Reflection and Some Solutions

The European Commission has no intention of taking the place of industrialists in aeronautics nor does it intend implementing an industrial policy for the sector, but it is suggesting a strategic reflection to the Twelve and to its sector with a view to ensuring competitiveness in the sector. Further to this, the completion of the Single Market could provide an institutional support framework which could be more suited to the needs of the industry.

The Single Market should not affect the structure of demand for commercial wide-bodied aircraft. On the other hand, other sectors of the civil aviation industry—regional transport aircraft, executive aircraft, light aircraft, civil helicopters—where the major outlets are predominantly national, will have to adapt to stronger competition. Moreover, these are the areas in which the European industry is in the best position. It occupies roughly two-thirds of the world market in helicopters.

The Commission, in its strategic approach, has identified seven areas in which the changes involved in the 1992 process will particularly affect the aeronautical industry. In corporate law, the status of the European public limited company will allow the setting up of an industrial and economic management structure geared

to the market. In the field of taxation, the elimination of the double taxation decided by the Twelve in June 1990 will result in the abolition of obstacles to cross-border cooperation between companies. The control of concentrations should take the strong world competition to which the European aeronautics industry is faced into account. The grouping of companies in the sector at a European level will improve their competitiveness in relation to the industry in the United States. To illustrate this, the Commission points out that the average turnover for the three largest European companies (British Aerospace, Aerospatiale, and MBB) was ECU4.5 billion in 1988, against 11.5 billion for their three major American competitors (Boeing, Lockheed, and McDonnell Douglas). The technical barriers resulting from differing standards and regulations between Community countries are also a handicap which the American industry is not faced with. This is why a policy on standards and certification is necessary.

Bringing insurance-credit systems into line Community-wide will also improve competitiveness. For the moment, the execution of a single contract for export involving several Community countries often requires separate approaches to be made to each of the national organisations responsible for export credits. Consequently, companies usually only approach their usual

lending institutions to the detriment of their competitiveness. Mr. Bangemann will also submit some ideas on Research and Development. In fact, contrary to what is happening at the level of production, European enterprises cooperate very little at the research stage. The Commission recalls that in March 1989 the Twelve adopted the BRITE-EURAM [Basic Research in Industrial Technologies for Europe - European Research on Advanced Materials] research programme, which runs until 1992 and which plans a two-year exploratory phase to benefit research in aeronautics, which should result in stimulating cooperation in this field. Finally, on the question of national subsidies, the Commission notes in its report that the international context requires that the European industry develops its competitiveness from its own resources. Maintaining a system of free competition which respects the regulations laid down by GATT [General Agreement on Tariffs and Trade] is one of the Community's basic founding principles. The Commission hastens to add, however, that competition in the past has been marked by major subsidies worldwide. The ultimate goal remains the improvement of competitiveness of the aeronautics industry, the report concluded, and this implies a progressive reduction in state subsidies. The extent and scheduling of this will also depend on the efforts made by the European industry's competitors.

Esprit II Program Interim Report Released

91MI0019 Bonn *TECHNOLOGIE-NACHRICHTEN
MANAGEMENT-INFORMATIONEN in German*
26 Sep 90 pp 15-16

[Text] The second "major" invitation to tender issued under ESPRIT [European Strategic Program for Research and Development in Information Technologies] II covers the following areas:

- Information processing systems (IPS);
- Office and business systems (OBS);
- Computer-integrated manufacturing (CIM).

The deadline for receipt of tenders was 10 January 1990. A total of 449 applications was submitted, and they were reviewed by 216 experts in Brussels early in 1990. Selection of the projects to be subsidized has been concluded. A total of 104 projects for an overall sum of 570 million European Currency Units [ECU] has been approved, including 73 projects with German participation.

Moreover, 43 "exploratory actions" are being subsidized in preparation for future research and development projects. It is gratifying to note a clear increase in participation by small and medium-sized companies, from both the FRG and other countries. The invitation to tender and actions listed were accompanied by a large number of measures such as informative events, seminars, and workshops on ESPRIT that Directorate General XIII arranged last year. Suffice it to mention here

just the two heavily attended "Proposers' Days" in Brussels or the major ESPRIT Conference in late November 1989.

Directorate General XIII's running of the ESPRIT program has on the whole proved smooth and effective, thanks, no doubt, to the experience gained with ESPRIT I. The more streamlined procedures and the improved management of ESPRIT have meanwhile been welcomed by all the partners.

The participants too are experiencing fewer problems in preparing, applying for, and carrying out ESPRIT projects. Many employees with the industrial companies, research institutes, and universities participating in ESPRIT II have experience from ESPRIT Phase I and realize and appreciate the many positive aspects of international cooperation.

A more open-minded attitude toward the EC is discernible on the whole in the FRG, combined with a greater readiness on the part of the computer engineering companies to cooperate in EC programs. This is also reflected in the gratifying increase in the percentage participation of German companies and research institutes in Phase II of ESPRIT, as compared with Phase I.

The German contact for those interested in the ESPRIT program is Dr. H. Schuh, German Aerospace Association, Department MDF-TK, Tel. 02203/601-3403, Fax 02203/601-3017.

France: 1991 R&D Budget Published

91WS0028A Paris *AFP SCIENCES in French*
20 Sep 90 pp 1-7

[Article: "Civilian Research Budget: Nearly 49 Billion Francs in 1991"]

[Text] Paris—The French civilian research and development budget (CRDB) will climb to 48.6 billion French francs [Fr] next year, with emphasis laid on industrial research, employment, training, and bolstering the effectiveness of basic research stated Mr. Hubert Curien, research and technology minister, on 19 September.

In commenting on his budget plan to the press, the minister stressed that, with a 7.3 percent increase over 1990, or a rise of Fr3.3 billion (BF), "we are moving toward the legendary 3 percent" of gross national product (GNP). "According to initial estimates," he added, "we could reach 2.45 percent in 1991, compared to 2.38 percent in 1990. France has pulled ahead of Great Britain and ranks fourth in the world, behind the United States, the FRG, and Japan." The budget estimates break down into a 6.1 percent increase for the portion directly distributed by the Ministry of Research (26.1 BF compared to 24.6) and an 8.7 percent rise for that allocated to other ministries.

On the question of industrial research, Mr. Curien said that "despite an approximately 10-percent increase in

the efforts of companies each year, their research expenditures are still inadequate. We must therefore encourage them along that line. In 1991, over Fr5.3 billion will be spent through different aid procedures, or over 10 percent [of the budget].” Money allocated to the National Agency for the Upgrading of Research (ANVAR), which jumped nearly 14 percent, will reach Fr963 million (MF). It will be used to develop programs for upgrades and innovations in small and medium businesses and industries.

The technological development programs are also examples of efforts to promote industrial research. Appropriations for civil aeronautics programs have leveled out at 2,915 MF. “This is explained,” Mr. Curien stressed, “by the fact that some programs are complete and others have reached maturity, while three new ones are underway. Efforts will be continued on the Airbus 330-340 and the CFM 56 engine, and there are plans to launch the powerful-thrust engine at SNECMA (National Aircraft Engine Research and Manufacturing Company) in collaboration with General Electric, the new Dassault business plane, the Falcon 2000, and the Arriel 2 helicopter engine.”

Space appropriations are up nearly 13 percent (8,119 MF compared to 7,186 MF), and will spur the “potential rise” of the European Ariane-5, Hermes, and Columbus programs. They also incorporate France’s participation in two new European Space Agency (ESA) programs: ERS 2 (earth observation satellite using radar techniques) and DRTM (ground/orbital-infrastructure telecommunications).

Finally, the budget allocation of the Atomic Energy Commission (CEA) is rising 1.2 percent (6.3 BF against 6.2 BF). This is a new trend which, combined with a realistic assessment of outside resources, should enable the CEA to complete structural reforms undertaken.

The policy to rally scientific employment which was initiated in 1988 will be continued with the creation of 650 researcher and engineer, technician, and administrative staff (ETA) jobs. Of the 319 researcher jobs, 304 will involve EPSTs [expansion not given] and will help meet the 4-percent recruiting target set by the Plan law, if possible departures are counted.

To ease the movement of researchers into higher education, the statutory terms established this year, and which have given good results, will be renewed in 1991: This will create 100 positions in the higher education budget for hiring of EPST researchers.

Priority, however, will be given to creating ETA jobs. “All the laboratories told us they needed support personnel. So for the first time, we are making a greater effort to bring in ETAs than researchers,” said Mr. Curien.

Education through research, he continued, will also be given special attention. Expenditures will total nearly 1.2 BF. Seven hundred MF from this package will be set

aside for research grants, to add 450 new ones to the current 2,800. Their value will be increased to Fr7,400 a month (compared to 7,000), with a possible additional 2,000 for teaching services. “Doing a little teaching is an extra asset, whatever your career,” commented the minister.

Furthermore, about 270 MF will be available to train young engineers or advanced technicians through research (CIFRE, FIRTECH, and CORTECHS) [expansion not given]. A total of 4,000 aid grants will be distributed in 1991, compared to 3,450 in 1990.

Appropriations to basic research organizations are up over 8 percent (19.8 BF compared to 18.3)

The CNRS (National Center for Scientific Research), up 7.2 percent, will encourage the establishment of new interdisciplinary programs to better structure its efforts in the coming years. These include IMABIO, on bio-engineering of macro-molecules, COGNISCIENCES, on cognitive sciences, and ULTIMATECH, on stretching techniques to their limits. Resources for PIREN, an environmental research program, will also be substantially boosted. Program support will also enjoy a marked increase (up 6 percent), to shore up funds available to laboratories and researchers for carrying out their projects.

INSERM (National Health and Medical Research Institute) appropriations will also rise significantly (up 16.2 percent), in part as a result of the transfer of certain monies allocated to AIDS research. INSERM will also focus its efforts on human genome and public health research.

INRA (National Agronomic Research Institute), up 9.5 percent, will continue work begun in 1990 with the start of two programs: AGROBIO, for support of research in agro-food industries, and AGROTECH, on the economic and social aspects of agriculture and animal husbandry.

ORSTOM (Bureau of Overseas Scientific and Technical Research), up 9.8 percent, will refocus its efforts mainly on the study of how ecosystems function and environmental preservation, and on agriculture in fragile tropical environments.

INRETS [expansion not given], up 9.8 percent, will concentrate its resources on getting the Driving Simulator project underway, in conjunction with auto manufacturers.

INFREMER [expansion not given], up 51 percent, continues its plans to renew its fleet, in particular by the construction of a ship with Mediterranean facade.

AFME (French Energy Management Agency), up 5 percent, will concern itself in particular with enlarging upon its work in the Clean and Economical Vehicle Program.

Finally, the Paris Pasteur Institute (up 8.5 percent) will open the new retrovirus building devoted essentially to the battle against AIDS.

In the ministries, primary stress will be laid on university research, appropriations for which will grow nearly 10 percent (about 2 BF compared to 1.8). "It is a matter," Mr. Curien explained, "of doing our part to support the government's plan to renovate higher education: Money for laboratory operating expenses will rise 6.4 percent and a special effort will be made to construct university buildings for research."

Environmental research appropriations will climb by more than 20 percent in order to bring them closer to the level in other countries, and agricultural allocations will rise by nearly 7 percent, with priority given to training through research and to agro-food industries.

Finally, appropriations for the Transportation Research and Innovation Fund (FARIT) are up nearly 30 percent, to finance a research and development program for innovation and technology in land transportation just launched by Mssr Fauroux and Delebarre and the principal industrial parties.

"It is sometimes said," Mr. Curien concluded, "that research investment is primarily directed toward big programs. Nothing is further from the truth: in three years, the CRDB has increased by Fr9.4 billion, or nearly 25 percent. Organizations and ministries received an additional 47 billion, or 22 percent, the big programs 2.9 billion, or 20 percent, and industrial research 1.8 billion, or 50 percent more. Half of all new appropriations have therefore been allocated to organizations and ministries."

CRDB for 1991		
	Amount in Millions of French Francs	91/90 Change
Big Programs (CEA, CNES, Civil Aeronautics)	17,396	+6.4%
Industrial Research (Support Appropriations)	5,326	+9.6%
Organizations and Ministries	25,950	+7.4%
Ordinary Expenditures	17,688	+8.1%
Program Support	4,583	+5.8%
Other Programmed Allocations	3,679	+6.3%
CRDB (in Ordinary Expenditures + PA)	48,672	+7.3%

France: LETI Transfers BICMOS Technology to SGS-Thomson

91WS0042A Paris ELECTRONIQUE ACTUALITES in French 5 Oct 90 pp 1-16

[Text] While presenting TEC '90 to the press, Mr. Jacques Lacour, Leti [Laboratory for Electronics and

Data Processing Technology] director, announced that a BICMOS 1.2- μ m line-width technology had been transferred to SGS-Thomson. The transfer is virtually complete and the production line of the Grenoble SGS-Thomson plant that was outfitted will be able to produce in volume starting in early 1991. SGS-Thomson and Leti are now putting the finishing touches on yields. The analogue BICMOS 1.2- μ m technology, christened HF3CMOS, was tested and validated: An RGB (red, green, blue) decoder was made on a 35-mm² silicon surface. The circuit filters and dematrixes the luminance and chrominance digital signals and converts to analogue components (red, green, blue) for improved- and high-definition television. It has an analogue (8-bit analogue/digital convertors) and a digital portion.

Other Circuits in the Works

Other circuits will follow the above coder: one incorporating data segmentation and digital and graphic processing; a Nicam audio decoder for northern Europe; a multi-standard television circuit including chrominance, bending, and intermediate-frequency generation circuits controlled by a microprocessor; and a D2MAC communications set with digital sound processor and associated video and control circuits.

LETI's Programs

The circuits are initially being made with BICMOS 2- μ m line-width technology at SGS-Thomson. This BICMOS 1.2- μ m technology will be supplanted by another now under study: a BICMOS 0.8- μ m line-width technique, which should be ready for volume production by 1996.

And according to specialists, it is at mid-decade that the BICMOS market should take off: It is expected to reach 2 billion dollars by 1993. SGS-Thomson, which invested in BICMOS in 1993 (sic), targeting the dedicated-circuit, telecommunications, and HDTV-circuit market, posted sales of 12 million dollars in that division in 1989.

Leti, which is heavily involved in Jessi, wants to complete installation of the 41 building inherited by the Jessi [Joint European Submicron Silicon Initiative] program. The equipment installed will make it possible to treat silicon wafers 150 mm in diameter and to use a CMOS 0.5- μ m (and smaller) line-width technology. But management must do its part to complete the installation program: 37 million French francs were allocated in 1990, more than another 200 million are needed over 1991 and 1992.

Mr. Lacour told us that Leti, associated with the Norbert Segard Center (Cnet-Grenoble) in the Gressi consortium, plans to work even more closely with its prestigious partner within Jessi, in order to form an unbeatable pair "at the top level of European industry."

Leti's director said it was involved in research at three different levels: very short-term research in collaboration with a manufacturer (BICMOS transfer to SGS-Thomson); medium-term research on imperative manufacturing needs (work on the 0.5- μ m CMOS within Jessi); and, finally, longer-term research. Even in the latter case, decisions are made after consultation with a committee of experts from outside Leti. That, for example, was how work on neuro-mimickry circuits was defined. Research has so far reached the simulation and evaluation stage, and the connection problems that go with it. To circumvent those problems, Leti is working on solutions involving optronics and "third-dimension interconnections."

In optronics, Leti made a name for itself by developing a flat-screen process that was not picked up by any European manufacturer. The Japanese company Stanley is currently bringing out the first products, which will equip micro-computers.

Boxed Material: The Process

The 1.2- μ m BICMOS process used by SGS-Thomson is characterized by: buried n+ and p layers, n-type epitaxy, p and n boxes, a weakly doped drain structure created with an oxide spacer, a polysilicide layer, and two metal layers. The CMOS part is powered with 5V and the bipolar part with 12V. The cut-off frequency of the bipolar transistors is 7 GHz for the NPN and 2.5 GHz for the PNP.

French Atomic Energy Agency To License Electron Accelerator

91WS0042B Paris *ELECTRONIQUE ACTUALITES*
in French 12 Oct 90 p 3

[Article by R. Font: "CEA: An Electron Accelerator for Industrial Use"]

[Text] The CEA [Atomic Energy Agency] is negotiating with several manufacturers, all of them European, on the sale of a license to manufacture an electron accelerator, the only one of its kind and essentially intended for industrial use, notably in the field of electronics.

In a 3 October press conference about the accelerator, christened Rhodotron, Mr. Philippe Garderet, head of DEIN (Electronics and Nuclear Instrumentation Department, a Leti division) did not want to disclose the names of the interested manufacturers (some of whom are French). He said that the industrial partnership agreement was expected to be signed in the coming months. We did learn, however, that the MeV Industrie Company was among the manufacturers in contention.

The Rhodotron was developed at Saclay in the research instrumentation division (part of DEIN). At the present time, only a prototype with 70 kW of power exists. The machine, which cost 3.5 million French francs [Fr], emitted its first beam last March, and nominal power tests are underway. Initial results are "very promising."

The CEA is looking at power levels on the order of 250 kW for future industrial versions, at costs that should approach Fr6.5 million. If a technology transfer agreement is ultimately reached in the coming months, studies and testing for such a machine could begin as early as 1991, says the CEA.

Initially designed primarily for food ionization, the CEA explains that the accelerator could be applied in many, varied ways, for example in high-powered X-ray imagery and industrial irradiation (polymerization, cross-linking of plastics).

Speaking at the press conference, Mr. Theo Sadat, general manager of MeV Industrie, asserted that ionization in general represented a "very big" potential market, and that polymers in particular offered "several market niches" for a machine like the Rhodotron. He said there might also be several applications for the machine in the semiconductor industry. "I am certain that within a very short time many people will buy a machine like it," he added.

The Rhodotron's originality compared to competing systems such as electrostatic accelerators lies in its compactness and, especially, its low cost: It is cheap to build, operate, and maintain. In particular, it is possible to use simple and inexpensive HF generators, the CEA stresses. The prototype incorporates a Thomson-CSF generator. "The Rhodotron is a brilliant idea," said Mr. Sadat.

The Rhodotron's beam energy is especially good at 1 to 20 MeV and its beam power especially high at 10 to 200 kW.

Another valuable feature of the machine is that it can be easily incorporated into a production line.

Continuing its work to develop the system, the CEA is now tinkering with an automatic starting device to be incorporated into industrialized versions of the machine, which the DEIN hopes will be ready soon.

Unification Creates Many Problems for German Patent Offices

91WS0061A Duesseldorf *VDI NACHRICHTEN*
in German 12 Oct 90 p 14

[Article by Egon Schmidt: "Make One From Two: Ex-GDR Patent Authority Absorbed Into German Patent Office"; first paragraph is VDI NACHRICHTEN introduction]

[Text] Munich, 19 Oct (VDI-N)—On 3 October 1990 the former GDR patent office was in fact absorbed into the German Patent Office (DPA) in Munich; however, certain transitional regulations will be valid for a while. An "extension law," yet to be written, will settle important questions of validity and exploitation of existing patents.

Since the first Wednesday in October, all applications received by the DPA and all patents that the DPA issues on them are "valid in the entire territory of unified

Germany," DPA president Dr Erich Haeusser explained the current situation at a press conference in Munich. Furthermore, so-called "priority" may be claimed for applications submitted to the East German patent office before that date but on which patents were not yet issued. In contrast, "applications submitted to the East patent office and patents issued on them" before that Wednesday "are valid for the time being only for the former territory of the GDR."

Transitional Regulations in the Offing

Analogously, "applications submitted to the West patent office and patents issued on them" before that Wednesday "will for the time being only be valid for the former FRG territory." Meanwhile, according to Haeusser, "the possibility of extending the patent protection granted" will not be resolved until next year with a law which would also contain appropriate transitional regulations."

With this future extension of existing rights "to the other respective patent territory," there will be numerous conflicts concerning which intensive discussions still have to be held "with those parts of the economy affected." However, there is already a regulation in the unification treaty pursuant to which protection is assured in certain cases of conflict.

It was learned at Munich's DPA that anyone who operated on the premise that no patent existed in one of the two sections of Germany had this protection—i.e., anyone who, "confident of this lack of a patent, undertook negotiations for use or obtained a patent himself." However, all of this only applies for applications submitted before 1 July 1990, i.e., before the beginning of the monetary union.

Also, regarding conflicts Haeusser stated that many regulations would apply which had already proven their worth in general patent law and among which other aspects, in addition to priority, were often considered. These might, for example, also include coexistence solutions and other constructions.

It is also significant that for all applications received before 3 October in the East or West German patent office the patent law or the examination regulations of the respective former office apply.

In connection with the takeover of the East German patent office, Haeusser pointed out the fact that patents in the West confer "exclusivity rights," on the basis of which the holder of the patent can specify what becomes of the invention. On the other hand, the GDR had economic patents which could be used at will in exchange for compensation and which permitted the inventor to receive only a small honorarium. For this reason, according to Haeusser, "No decisions which are so far-reaching could be based on East German patents, as would be the case here in the West."

In addition to the economic patents, there have been exclusivity patents for a long time in the GDR; however, they are virtually nonexistent among the applications from GDR inventors. In contrast, "foreigners" sought this economically attractive patent for approximately two-thirds of their applications. Since the middle of this year, virtually all the patents granted have been exclusivity patents, with the possibility still existing until the beginning of 1991 of having old economic patents converted into this deluxe form of patent upon formal petition.

Haeusser thinks that it is likely that many applicants waited for the day of German unification before they submitted their applications targeting the entire territory. Consequently, he expects 8,000 additional applications for each of the next two years—or a total of 50,000. The approximately 450 employees from the former East German office who are to be added to the staff of the Berlin office of the DPA will contribute to their processing. However, the examiners still have the tremendous backlog of 30,000 to 40,000 examination petitions to process, which is likely to become acute primarily as a result of the merging of the two offices.

This temporary additional load will increase the average processing time of the DPA with its current 720 examiners from 22 months to between 25 and 26 months, fears Haeusser.

Last but not least, Haeusser also expects the takeover of the East German office to bring a clear improvement in research and examination, because East German patent documentation, which is "in excellent condition," includes important Eastern patent documents, which are not accessible here classified by technical specialty; specifically those from the USSR. "In the future, we will include all of these in the evaluation of the prior art—which is often very high in the USSR," announced Haeusser. At the same time, the former East German examiners brought along relevant language expertise.

Many Inventions Could Not Be Put to Practical Use

Regarding the usefulness of former East German patents, DPA's president, who absolutely wants to "avoid the mistaken impression of a takeover by force," stated: "Here I have a rather positive impression, because in many areas, promising valuable technology was developed"; and it may be "only" a question of "making up for serious deficits in the supply of materials."

It may well be true that the GDR had "exemplary controls on the recognition of technically creative individuals," as Haeusser expressly emphasized; however, the socio-economic system was structured in such a way that "many inventions could not be put to practical use."

Haeusser, who sees "a great need for catching up in schooling" especially in the (patent) attorneys of East Germany, and to a lesser extent in the patent engineers, also reported "close contacts" with virtually all countries of the former East Bloc, with the exception of China

which has long been oriented toward the DPA in matters of patent law. And he was able to report that all those countries were already planning new regulations for patent law "appropriate for market-based economic conditions...."

Italy: European Research Agency Established

90MI0357 Milan *ITALIA OGGI* in Italian 15-16 Sep 90 p 34

[Text] APRE (Agency for the Advancement of European Research), a nonprofit organization designed to strengthen Italian participation in European R&D and technological innovation programs, was established yesterday in the presence of Minister Ruberti. It was sponsored jointly by the Ministry of Universities and Scientific and Technological Research and the Commission of the European Communities, and established by four organizations whose primary common role is to promote applied research in Italy: Confindustria [General Confederation of Italian Industry], ENEA [Italian Committee for R&D of Nuclear and Alternative Energies], FAST [Federation of Scientific and Technical Associations (Milan)], and Mondimpresa (Agency of the Chambers of Commerce to Internationalize Companies). The president of ENEA, Fabio Cistella, will be the chairman of the agency for an initial period. Other organizations have already demonstrated their intention of becoming members. These include: IMI [Italian Institute for Financing Personal Real Property], AIRI (Italian Industrial Research Association, Confapi [National Confederation of Small Manufacturers], IST (National Institute for Cancer Research) and the National Society of University Rectors and many others.

APRE has therefore been established as a private organization whose goal is to be of public utility. It intends to interact closely with the Italian public research sector, primarily under an agreement with the Ministry which is currently being defined and through a regular working relationship with the CNR [National Research Council] and other public research organizations and universities. According to a press release: "The common denominator is the awareness that the growth and internationalization of Italy's research system, together with the considerable strengthening of its participation in scientific and technological cooperation at the European level, is the prerequisite to consolidating Italy's position among the most advanced countries."

It has been estimated that Italy receives only 10 percent of the resources that the EC allocates to the R&D sector, which is approximately half of what France and the FRG receive. This is decidedly little compared to Italy's European ambitions. "Furthermore, the importance of this initiative takes on an even greater value since it coincides with the beginning of Italy's six-month term as president of the EC. APRE is already operational with its small group of experts working at the Ministry. It therefore represents an instrument that is designed to provide information on funding and scientific and technological

cooperation at the European level more effectively by providing information, documentation, and assistance to all those organizations with an interest in participating in European research programs.

Italy: Milan Research Consortium's Laboratories Described

90MI0375 Milan *FATTI E NOTIZIE* in Italian 3 Sep 90 p 7

[Excerpt] Milano Ricerche was established in June 1986 and includes the following organizations: CNR [National Research Council], IRI [Institute for the Reconstruction of Industry], the Milan Polytechnic, the Bocconi, Cattolica, and Statale universities, the Milan Chamber of Commerce, Lombardia Fincapital, Italtel, and numerous other public and private sector companies, including the Pirelli group's Progetto Bicocca company.

The president of Milano Ricerche is Professor Giampiero Cantoni, and its director general is Professor Archetti, who summarized the principal goals: "An 'Innovation Center' was created to establish a permanent link between academic and industrial research. Particular attention is given to small and medium-sized companies for which research activity would not be economically feasible."

One of the planned initiatives is considered to be of particular and immediate interest: the establishment of a center for the quality certification of products and manufacturing systems for which industrial sectors have a growing need, particularly in their trade with other EC countries as the open market of 1993 approaches.

Two Milano Ricerche laboratories have already been established at the Technological Center of Milan and a third, the Laboratory of Cellular Spectroscopy, which will develop innovative diagnostic equipment for organic tissues, will become operational at the end of the year.

The first to be established, the Sensor Laboratory, was inaugurated in April last year, and its specific field of activity is the development of devices to monitor toxic gases.

The official inauguration of the Special Materials and Monocrystals Laboratory took place on 4 June and was attended by the rectors of the Statale University, Paolo Mantegazza, and the Polytechnic, Emilio Massa. This laboratory is involved in the preparation of a whole series of new materials with applications in the most advanced sectors of electronic and optical telecommunications as well as in high energy physics experiments.

These are "strategic" materials which can control technological innovation in industry worldwide. One example is the current excitement in the field of international silicon production. Over the last seven years we have witnessed the exit of the Americans from the

market and a duopolistic concentration by the German MECM [expansion not given] and the Japanese Shinetsu companies. In the future, polycrystalline silicon will occupy an increasingly larger place in electronics, a material which to date has aroused interest only for its photovoltaic applications and in microelectronics.

The scientific director of the Special Materials and Monocrystals Laboratory is Professor Sergio Pizzini of the Department of Chemistry-Physics and Electrochemistry at the Statale University of Milan.

"We will not limit ourselves to the identification and characterization of materials," Pizzini stated "an important part of the work will be oriented to developing manufacturing technologies on a scale that can be easily transferred to the manufacturing phase."

Pizzini continued: "In the field of monocrystals, which must possess a very high degree of purity and order (crystal lattice perfection), attention will be dedicated primarily to barium fluoride (the research has been commissioned by the National Institute of Nuclear Physics) and to potassium niobate." For those interested in knowing more, barium fluoride has very promising characteristics in the detection of gamma rays and a good resistance to radiation damage. Therefore, its applications are primarily in high energy physics. Potassium niobate, instead has displayed very promising characteristics as a detector of radiation and thus has applications in photonics. However, as opposed to lithium niobate, it is not available in the market. "This is a case of 'feasibility' studies," commented Pizzini, "based on theoretical knowledge and experiments carried out on a small scale in university laboratories, that could be defined the 'design' of new materials aimed at resolving advanced technical problems."

The laboratory's latest study involves a series of experiments on synthetic silicon, a material with an extremely high degree of purity. A thorough knowledge of the properties of silicon will lead to a better understanding of the behavior of silicon glass injected with germanium oxide for the manufacture of devices that direct light, such as optical fibers.

In the near future, the activities carried out by Milano Ricerche at the Technological Center will take advantage of an even closer collaboration with universities. Two new degree courses and research facilities connected with the University of Milan are planned at Bicocca for 1992. They are Materials Sciences, and Environmental and Earth Sciences. The program for the transfer of scientific initiatives from the University of Milan to the Technological Center will therefore establish important synergies and resolve the serious problems of space in the university structure. [passage omitted]

Italy: Activities of City Research Consortia Described

91MI0016 Milan LITO in Italian Oct 90 pp 9-16

[Article by Beppe Croce entitled: "The City Research Consortia"]

[Text] There are currently nine entities scattered across the nation from Venice to Catania, some of them already three or four years old. Universities, research organizations, large companies, industrial associations, and local boards are listed in their charters.

These diverse players are called upon to cooperate in three major areas:

- advanced research;
- the transfer of innovation;
- training for excellence.

The effectiveness of the formula promoted by IRI [Institute for the Reconstruction of Industry] should thus be evaluated on this basis.

A Flexible Formula

In most respects the City Research Consortia are similar to the proposals for an Italian network of scientific parks. But there is a substantial difference when compared with the approaches taken for similar experiments, both foreign and domestic, such as Tecnopolis in Bari, or Bicocca in Milan.

Scientific parks are traditionally established as physical places. In France, for example, scientific parks are primarily characterized as major urban projects (from Sophie Antipolis to Montpellier). In other words, they are territorial areas extensively fitted out with buildings and communication infrastructures, offering various economic opportunities (the first among these is rent). Then, whomever enters the area determines how to use the space, and for what purpose.

IRI's proposal, on the other hand, groups various parties together, first of all around the concept of an association—the consortium. In the consortium, public and private research can collaborate on specific projects without bureaucratic red tape. In this way, the project's backers intended to achieve the dual goal of minimizing investments (since they certainly do not have the enormous resources available to public administrations beyond the Alps), and minimizing the risk of creating empty boxes.

Only in a few cases, as we will see later, is the creation of real scientific parks the goal of the consortia. Apart from being economical, this formula is also very flexible. A minimal number of articles of its corporation were established for all the consortia (a set fee of 50 million lire per partner), the remainder have so far been delegated to the dynamism of the local parties.

A grassroots approach has therefore developed, so the various local experiences differ from the time they are founded. Among other things, the consortia have been established at different times, and in different combinations.

Diverse Models. The first consortium was founded in Genoa four years ago, based on the strong demands for revitalizing Genoa's public industry. This is the largest consortium, and it was explicitly based on the idea of a scientific park in the Ponente area. The latest consortium was established in Venice less than a year ago, with a strong orientation toward the problems of reclaiming the city. The consortium was founded, and is growing, on the basis of strong programs in various fields (sea activities, new materials in the lagoon, and so forth).

Milan is at the extreme opposite of the Venetian case: This consortium was intentionally developed without any advance programming. This is quite a pragmatic approach—allowing anyone with proposals to step forward—and this is in keeping with the milanese context: widespread affluence, extreme business diversification, and little need for intervention.

A unique case is the Agrital consortium, the only specialized consortium, and the only one not based in an urban setting. In fact, it was independently established as part of an IRI/CNR [National Research Council] project, and in November 1989, it became part of the City Research Consortia, with the involvement of the University of Tuscia (Viterbo). Agrital's goal is to develop agricultural technologies (as well as training and disseminating results in this area) and it makes use of the laboratories and facilities of the agricultural company IRI-SOGEA (formerly Maccarese).

Let us now take a look at the first concrete experiences, keeping in mind the diverse periods in which the various consortia were founded.

The Research Frontier

Important initiatives in the field of advanced research are advancing primarily in the centers in Genoa (CAD [computer-aided design], VLSI [very large-scale integration], and expert and sensory systems), Milan (advanced materials, sensors, and optical electronics), Pisa (aerospace), and to a lesser degree, Padua (remote control, real-time systems). The first products of any importance only started reaching a certain degree of development in the spring and summer of 1989, with the exception of CAD in Genoa, indicating that there have been some difficulties in the consortia's first years of existence.

Milan's High Technology Laboratories. Milan has developed a line of high technology laboratories in the Bicocca area over the last year: sensors, monocrystals, and advanced materials; a microspectroscopy laboratory is slated to open soon.

In general, the laboratories came into existence on the basis of specific research commissions from companies,

some of which were outside the consortium. In this way, the first project for the sensor laboratory came about in collaboration with a medium-sized advanced ceramics company in Brianza.

The monocrystals laboratory (there are three in the world: one in the United States, one in China, and one in France) was established as part of a contract with the National Institute of Nuclear Physics to develop barium fluoride monocrystal radiation detectors. The consortium's role was primarily to offer the appropriate operating structure for relationships between the companies and Milan's universities—especially the Polytechnic—which had been operating spontaneously for years. A typical example is the Autofaber consortium with IBM (International Business Machines) for industrial automation programs, which was created on the basis of a relationship that has already existed for years between IBM and the Department of Mechanical Engineering.

Pisa: The Space Center. Pisa is another university center destined to carry out a high technology role. The most substantial results achieved have been in the field of aerospace research, with the construction of the Space Center in June 1989 in collaboration with Aeritalia and BPD (which joined the Pisa Research Consortium specifically for this project).

The Department of Space Engineering at the University of Pisa already boasted excellent skills in the field of vacuum simulation (propulsion, aerothermodynamics, materials testing). Nevertheless, Italy has always lacked adequate structures to carry out experimental research. The opportunity for this came about with the European Space Agency (ESA), which proposed that the Italians acquire three pieces of equipment for its research programs, with characteristics unique in Europe (something similar exists only in Stuttgart).

Computer Disappointment. The role of Pisa Research in the field of computers—the principal objective in establishing the consortium—has been disappointing. Indeed, Pisa has been the stronghold of Italian computer culture for decades (the first Italian computer was created in Pisa, and it is here that the earliest proficiency in Unix and advanced languages such as Ada and Pascal was developed).

However, academic research has never received strong backing from industry capable of making sufficient investments in the think tanks of the Normale, the university, and the Scuola di S. Anna triangle.

Initial involvement in the consortium by companies such as Systems & Management, Intecs, and Data Management, together with the IRI-Finsiel companies, raised hopes that an advanced software hub might finally be established in Italy. But it did not happen, and Systems & Management and Intecs got out, accusing the consortium of being an Italsiel holding. They, in turn, were accused of not being willing to invest.

The new management of Pisa Research, under Pippo Torriani, already a leader in Pisa's research at Tecsiel, intends to create the basis to relaunch the project.

The CAD Center in Genoa. If the marriage between the university and industry in high technology is working in Pisa and Padua thanks to the fundamental role (and funds) of major European research companies, the driving force in Genoa so far has been IRI itself, and now the local chamber of commerce. Research in Genoa is oriented more toward consolidated applied research, and its strong point is in the CAD field. With four new laboratories on the drawing board, it will soon be strong in intelligent sensors. It is clear that in these two choices, the weight of companies such as Elsig, Ansaldo, and Marconi has come to bear. Genoa Research has consolidated various other fields related to computer graphics: territorial graphics (mapping), designing VLSI circuits, and multimedia author systems.

Two Major Science Park Projects: The Ponente Area of Genoa. The activity of Genoa's consortium is the only one strictly connected to an overall project for a scientific park. The consortium was created out of this project, which was requested by IRI, Ilva, and Italtimpi and approved by the Region of Liguria, and which involves reclaiming a hilly area of 500 hectares located on the Ponente coast (the Erzilli plain, the hills of Coronata, up to Polcevere on the sea), currently occupied by some fifty unused patrician villas. A model already applied successfully by various cities such as Glasgow, Metz, and Pittsburgh for revitalizing industry has been borrowed. This physical space will also be recovered for urban purposes and the establishment of new businesses and companies encouraged.

Already located in the attractive headquarters at Badia S. Andrea, the consortium, with its funds from the IRI grant for the reindustrialization of Genoa, has seen the founding of three small companies between 1988 and 1989, Ito (automation of steelworking processes), Biosensori, and Monitech (process instruments).

The Catania Center. Even the extreme south of the consortia network, Catania Research, has priority goals that involve designing an authentic scientific park.

An executive project of 125 billion lire has already been created for two centers (S. Sofia and Pantano d'Arce). The only thing missing is the funding, which should be forthcoming out of an agreement on programming between the Ministry for the South, and the Ministry for Scientific Research.

Three hundred people working in various university laboratories managed by the consortium itself should find jobs in the center. IRI itself is interested in this project, as are Agriculture Industrial Development and, in particular, SGS-Thomson, which has been collaborating with the University of Catania for some time now in research on power devices.

Research To Save a City. The experience of Venice is a unique one, with activities all oriented toward reclaiming the urban scene. The consortium is less than a year old, but it can already boast of numerous projects with extremely specific goals in which the main economic forces in the territory have joined together.

The projects already launched, around ten of them, fall within four fundamental categories:

- environmental and territory (for example, treating canal sludge, with Montefluos and Venice Services);
- restoration (new products with Siremont and Renh, and IBM and EDS for information systems);
- sea technology, the construction of a center is provided for, with Tecnomare;
- materials, and polymers in particular given the role of Montedipe of Marghera (for example, a project for the analysis and substitution of materials used for structures in the lagoon is currently being started).

Local Dissemination of Innovation

Experiences in the area of disseminating and transferring technology to small and medium-sized companies are still quite limited. Some university centers are bringing an endowment of good technical instrumentation. But frequently even elementary cognitive analyses are lacking. Economic and industrial skills are called for—rare in the academic world—and the real issues is designing authentic service centers.

Nevertheless, approaches of a certain interest are being implemented in three areas: Rome, Padua, and Pisa.

Rome: A Network of Small Service Centers. Rome Research has chosen a model for the small companies that is very different from the science park. Instead of a centralized location for high technology laboratories, they came up with a system of small service centers spread out across the region, connected by a network. The first concrete initiative, with Selenia's assistance, was the opening of four CAD-CAM [computer-aided design/computer-aided manufacturing] demonstration centers in the fields of electronics and mechanics. Another demonstration center for laser processing was opened in Pomezia, in collaboration with the Experimental Metallurgy Center.

Padua: The First Inspection and Testing Labs. Padua Research started off first of all with a survey (machine tools, components, clothing, shoes, furniture, refrigeration) and then drew up a strategic service project for each. Testing and inspection laboratories for three sectors have already been opened by taking advantage of the technological facilities of the universities:

- optical items (in collaboration with manufacturers from Belluno);
- commercial refrigeration, with a project that involves the entire "cold" chain, including transportation and warehousing;

- shoes, in collaboration with ENEA [Italian Committee for Research and Development of Nuclear and Alternative Energies], primarily for CAD-CAM instrumentation.

In addition to the local chamber of commerce, three leading companies of the consortium have been the prime movers in the dynamism of the initiatives in Padua regarding small and medium-sized companies, since they feel the need to see an improved quality in their subcontractors.

Pisa's Project for an Innovation Association. A crucial limiting factor in a good many of the technology transfer initiatives is the scanty involvement of their targets, the small and medium-sized companies, in the structures offering services.

Pisa Research is not in itself appropriate for similar involvement, given its consortium structure, and it is experimenting with formulas for an innovation association. Numerous entrepreneurs and local boards can take equal part in this at a low costs in order to create circuits of knowledge to start off with.

Service projects have already been started in three traditional sectors: tanneries, shoe factories, and furniture factories.

In the case of Pisa, the Innovation Center, that is, the structure encharged with distributing authentic services, was primarily established to coordinate independent service centers that already existed in the area (for example, Lucense of Lucca for CAD-CAM, or the Valdera Service Center).

Excellence in Training: A Proposal

For some time now in Italy, there has been talk of intermediate, pregraduate degrees, especially in engineering. This would make it possible to create pools of qualified personnel that are far more extensive than those currently available with the existing pool of scientific graduates. And even at IRI, some companies have already decided to get around the bureaucratic red tape required for reforms, by experimenting with two-year mini-degrees at the universities. This is Aeritalia's situation with the Turin Polytechnic, and also that of SGS in Pavia.

Similar projects are being outlined by Naples Research, once again with Aeritalia and Italtel, and by Catania Research. The project in Catania is supported by SGS-Thomson, Selenia, and Comphebus (an energy-saving company partially owned by ENEL [National Electric Power Company]). This projects has set up a 2,000-hour two-year course in engineering for high school graduates.

The Space Center in Pisa, on the other hand, will become the site for a degree program in space engineering beginning this fall.

As for the others, the most widely-used formula in all the consortia is to enlist young students writing their theses

or the new graduates to work on their various projects or laboratories, using the traditional scholarship system.

Of course, the opportunities are proportional to the enormous number of initiatives jointly carried out between universities and industry.

The COMETT [Community Program for Education and Teaching in the Field of Technology] EC projects are a new way of searching out resources for advanced training. This network of consortia is becoming a significant point of reference in Italy. Padua and Venice Research are already promoting a COMETT Veneto association because it is simpler to receive funding for training projects on a regional scale (the first projects will involve the multimedia field).

Possible National Role. In fact, the IRI City Research Consortia could play a very important strategic role here in Italy in promoting training for excellence oriented toward industrial policy.

This role would permit the thorny issue of university reform to be avoided and the tenacious opposition of those who, not without reason in my opinion, fear subordination of university structures to the interests of the company (often rather shortsighted in this country).

The network of consortia could become the privileged place for this type of training, where academic and industrial interests could come together without damaging the independence of true university research.

Obviously a project of this type requires a structure with adequate resources and a national-scale project so that it is not limited to a few scholarships.

And here we touch on the two sore points in the experiment with the consortia: the coordination of experience and the availability of funding.

The Limits of Laissez-Faire: The Government and Investments

In summary:

- Some doubts have arisen on advanced research in consortia such as Genoa, Milan, and in part, Pisa. Certainly the consortia's grassroots approach has produced more dynamism than produced so far by the traditional model of the scientific park, which often runs the risk of being a box that is every bit as empty as it is expensive.
- Regarding the transfer of innovation, the first attempts are under way now, so we cannot talk about results, unless they are Padua's partial results.
- Regarding training for excellence, we have the first embryos of a new university degree course (the mini-degrees) and opportunities for research courses offered so far to approximately 50 Italian graduates and students nearing graduation.

The consortia's experiences are anything but homogeneous with widely disparate approaches and results. This is not just because of the different periods in which they were founded.

From certain points of view, this lack of homogeneity is a sign of the formula's vitality, demonstrating its ability to cope with very different local realities: from situations of industrial revitalization such as Genoa's, to those of rethinking the urban model such as Venice's, to the strong business dynamism that is found in Milan, to the rich industrial background of a province such as Padua. So far, the national network and IRI have encouraged these local initiatives with a laissez faire attitude. On the other hand, IRI has acted more as a stimulator of initiatives and even its financial investments have largely depended on local consortia.

But the danger now that local machines have started up is the creation of disconnected (or overlapping) projects or initiatives in fields where the human resources and skills are scarce and have national value.

The potential of the city research model could be much greater both in the field of training and advanced research:

- if the network of consortia could work in a coordinated fashion while remaining a network and not a hierarchical structure: circulating their resources, creating common service networks (such as the CAD-CAM network project among Genoa, Pisa, and Milan) and becoming a critical mass when facing opportunities offered by European programs, and
- especially if government organizations and large public and private industry were really willing to make a minimum investment.

Many look to the French Anvar model, with its network of innovation agencies spread out across the country. The French government spends several billion francs each year on this network.

Without a doubt, the IRI model could bring about efficient results in a much softer way, even from the economic point of view, and with greater flexibility. But they certainly need more than the 40 million lire currently required from each partner, and which formally represents the consortia's only financial support.

The Consortia's Principal Lines of Research

	Principle Lines of Research	Principal Projects and Initiatives
Genoa	CAD	CAD Center
	VLSI	Semicustom Circuit Design Center
	expert and multimedia systems	ICAT [ILVA Computer Aided Training] prototype (client: Ilva)
	numeric simulation	
	intelligent sensors	sensor lab with four R&D groups
	advanced transport systems	Altrobus prototype
Milan	gas sensors	innovative gas sensors (client: XX)
	monocrystals and special materials	BaF ₂ monocrystals (client: INFN)
	microspectroscopy	lab with Bio-Rad
	automation	Autofaber (with IBM): SE for supplies
	electronic CAD	ASIC circuits (Italtel and SGS-Thomson)
	environmental technologies	
Rome	CAD-CAM	advanced languages for CAD networks (SPRINT Project)
	lasers	Demonstration Center (CSM and Selenia)
	electrooptics	development of sensors (Selenia and ENEA)
Pisa	aerospace	vacuum simulation (client: ESA)
	space robotics	control systems (client: ESA)
	advanced robotics	
	computer science	natural language analysis (client: XX U.S.)
	electronics	atomic-powered microscopy (BRITE)
Catania	microelectronics	
	new materials	
	fine chemistry	
Padua	computer science	remote control systems, Galileo Project (EEC)

The Consortia's Principal Lines of Research (Continued)

	Principle Lines of Research	Principal Projects and Initiatives
		control of purification network, province of Trento
	CAD-CAM	
Venice	environmental and earth technologies	treatment of Venice's canal sludge (with Montefluos, Venice Services, the city administration)
		standard CAD cartography (Siemens Data, Tecnomare, IBM, ENEL, and several others)
	restoration/conservation	new products for restoration (with Siremont, Renh, Cocea, EDS, IBM)
		general museum (Venice archives with EDS)
	materials	analysis/substitution of materials in the lagoon (Tecnocomp., Montedipe, Venice city administration)
		simulation of transportation/mobility in Venice (Fiat Engineering, AIVE, and CTV)
AGRITAL	agricultural technology	feed from vegetable residues
		fodder conservation (ECLAIR)
		use of probiotics for breeding
		new plants for oil for industrial use
		coastal forest areas

Principal Initiatives of the Consortia

	High Technology Labs and Centers	Services to Small, Medium-Sized Companies/Region	Education
Genoa	CAD center	CAD center	COMETT multimedia project
	mapping center	materials/components testing	CAD center
	multimedia system center		
	VLSI center (semicustom)		
	sensorial systems laboratory		
Milan	sensor laboratory	innovation center	two COMETT projects
	monocrystal laboratory		Italtel scholarships
	Autofaber consortium		SGS scholarships for PF Microelectronics
	CAD, VLSI, and ASIC centers		
	microspectroscopy laboratory		
Rome	electrooptics center	network of CAD-CAM centers	MUSIS project
		electronics sector	CAD-CAM-CAE [computer-aided engineering] courses
		mechanics sector	
		laser processing center	
		innovation center	
Pisa	space center	association of small and medium-sized companies	course in space engineering
	software laboratory	courses on managing innovation	Piaggio robotics scholarships
			computer science and telecommunications courses (formerly CNUCE [National University Center for Calculation])
			courses on managing innovation

Principal Initiatives of the Consortia (Continued)

	High Technology Labs and Centers	Services to Small, Medium-Sized Companies/Region	Education
Catania	scientific park (materials laboratory, biotechnology, computer science, fodder)	B-D [as published] for R&D and Graduates	mini-degree in Engineering
		testing materials/products	
Padua	CAD center	B-D [as published] Innovation small and medium-sized companies in the Veneto Region	multimedia training
		laboratory for testing and inspection (refrigeration, clothing, optical items)	CAD-CAM courses
		B-D [as published] metal and mechanical companies	
Naples			patents training
Venice	sea technology center	experimentation center	restoration scholarships
		citizen services	COMETT Veneto Association
AGRITAL	experimental agricultural company formerly Maccarese	reuse of state land, Province of Grosseto (3,000 hectares)	six full-time graduates
		technical assistance, training to developing countries	PVS [as published] training

Netherlands: Economics Ministry Announces Technology Policy

91AN0013 Amsterdam COMPUTABLE in Dutch
14 Sep 90 p 3

[Article by COMPUTABLE correspondent: "Strength/Weakness Analysis of the Dutch Economy: Economic Affairs Turns Its Attention to Data Communications Projects"]

[Text] The Hague—In the coming five years the Ministry of Foreign Affairs intends to pay special attention to application-oriented data communications projects and to the integration of electronic and media services.

Furthermore, the Ministry will turn its attention towards coordinating Dutch efforts in the essential field of data communications. This coordination will involve research, standardization, and a public awareness campaign.

This can be read in Minister of Economic Affairs J. Andriessen's report entitled "An Open-Frontier Economy," a strength/weakness analysis of the Dutch economy which was published last Wednesday.

Within the Company-Oriented Technology Stimulation Program (PBTS), research will be encouraged into the application of microelectronics in products and processes. This should prepare Dutch industry for the implementation of submicron technology being developed within the Joint European Submicron Silicon Initiative (JESSI).

During the period 1990-1995, an extra 960 million guilders will be made available for technology policy. The largest share (250 million guilders) will go to the

Technological Development Credits (TOK). This scheme will be altered in order to help medium-sized and large companies finance high-risk projects. The budget will be structurally increased by 40 million guilders each year. Unexpectedly, the subsidy scheme for wages of research and development staff is being retained. In principle, it will continue until April 1994. In addition, the Innovation-Oriented Research Program (IOP) will be continued.

Further, following a British example, the Ministry of Economic Affairs is to start an experimental project entitled "Experts in the Small or Medium-Sized Enterprise (SME)." This will involve the temporary placement of personnel with higher education in SMEs. In this way, the knowledge transfers between universities and institutes of higher learning on the one hand and SMEs on the other will become easier. New initiatives from education and industry to strengthen technological training in secondary vocational schools will be encouraged.

The successful NaBoNT program for continuing education of teachers in vocational training institutes will be extended to include teachers responsible for technology in the first grades of higher education. The system of Technical and Scientific Attaches will be extended within Europe.

The Netherlands does not present an industrial image to foreign investors, which has an impact on the educational system and the labor market. Technology is simply less popular than in neighboring countries. The climate in Holland for advanced technology activities is therefore rated less favorably.

In his report, Minister Andriessen points out the necessity for continual innovation. Technology is becoming

more important for industry. Everything is going faster and becoming more complicated. There is a trend towards shorter life cycles for systems and processes. The life cycle of a product in the electronics industry (hard- and software) has become extremely short. When 30 years ago a company could build up a lead of four to five years with a new product within the electrical technology industry, it now sometimes takes only a few months before a clone or rival product comes on the market.

A second important trend is the increasing interweaving of technological areas and scientific disciplines. Product or process improvements increasingly require the implementation of various technologies. Scientific breakthroughs are more likely to be the result of inter- and multidisciplinary work. In the coming years, really interesting developments are most likely to occur in fields where different technologies come together. These are known as the so-called "cross road technologies." Examples are mechatronics (a combination of mechanics and electronics) and telematics (telecommunications and information science).

The increasing importance of technology means that technological management will have to be integrated in business management. Over the past 10 years, Minister Andriessen has noted, information technology, in particular, has made an appearance in business life. Today one in three of all companies with more than 10 employees uses information technology in one way or another. For companies with more than 500 employees that becomes two in three.

Even so, Dutch industry still falls behind the competition on some points. This is the case, for instance, with "internal and external integration." Dutch products generally contain fewer microelectronic components than products of foreign origin. In the area of advanced electronics such as semicustom ICs, the Netherlands is even more behind, and this despite the presence of an electronics concern such as Philips within its borders.

It is, however, pointed out that the flexibility in large sections of Dutch industry has increased and that the extent of automation has expanded greatly. In this connection, Dutch industry has not really fallen behind its foreign competitors. Depending on the market in which they operate, SMEs can still strengthen their position by a broad-scale use of automation systems. This requires a well-functioning information infrastructure. The connection of automation systems both within and between companies, however, still constitutes a bottleneck. Government policy will also be to look into this.

Dutch 1991 Research Budget Discussed

*91AN0015 Rijswijk POLYTECHNISCH WEEKBLAD
in Dutch 20 Sep 90 p 7*

[Article: "Technological Research in the Netherlands Must Be Strengthened"]

[Text] Compared with other countries, the Netherlands provides relatively little money for beta [exact science]

research and a large amount for alpha [humanities] and gamma [social science] research. So writes Minister of Science and Education J.M.M. Ritzen in the 1991 Science Budget, which has been presented to Parliament together with the overall budget.

Total 1991 expenditure for scientific research will be 11,845 million guilders. This is an increase of about 3 percent over 1990. From this total, the government's share will be 4,279 million guilders, about the same as for 1990. The increase in expenditure is thus mainly coming from industry, which in 1991 will bear 55 percent of all research expenditure, compared to 40 percent for the government. The remaining 5 percent will come from abroad and from various noncommercial organizations. As a percentage of the gross domestic product, research expenditure shows a slight decrease from 2.28 in 1990 to 21.23 in 1991.

Change of Accent

According to a recently published study, the emphasis within the Dutch pattern of expenditure is shifting from natural sciences toward social sciences and humanities. In comparison with average expenditure in the United Kingdom, France, West Germany, the United States, and Japan, the Netherlands gives far less money to beta sciences (72.5 percent of the total as opposed to the average 85.1 percent). Instead, more money goes to gamma sciences (18.9 as compared to 9.8 percent) and alpha sciences (8.6 as compared to 5.1 percent). The most important reason for this is the fact that in the Netherlands, direct university funding is dependant on student numbers within the various university departments. During the past 15 years, subjects such as law, business administration, economics, history, and modern languages have become more popular and received large amounts of money. Minister Ritzen wants to change this trend, both by increasing the number of students in beta sciences and by making funding less dependant on student numbers. Thus, beta research would be strengthened, "particularly if it is directed towards social developments and the environment." Indirect university funding, too, should be increased in order to make research financing more independent.

Investigations

Because science and technology are becoming increasingly important, the Minister of Science and Education finds that science policy must change direction in the coming years. Exactly how that must be achieved will be clear after a number of "investigations into scientific trends" are set up. A yet to be set up consultation committee will put together an agenda for national seminars on these investigations. The 1993 science budget will for the first time announce new options based on these investigations.

Top Quality

Top quality and internationalization are other keywords in the 1991 science budget. Top quality research on an international level will be secured, among other means, by the creation of research institutes. The Rinnooy Kan Commission will produce a recommendation later this month in which the setting up of these research institutes "will be energetically embarked upon."

Subsequent internationalization of research must take place through, among other means, an increase in the Dutch participation in EC programs such as the European Strategic Program for Research and Development in Information Technologies (ESPRIT), Research and Development in Advanced Communications in Europe (RACE), and Developing European Learning Through Technological Advance (DELTA).

Ethical Aspects

Social and ethical aspects of scientific and technological research will receive more attention in the coming years. The Netherlands Organization for Technological Aspects Research (NOTA) is currently making a survey of those committees which are involved with these problems. On the basis of this survey, the minister will draft a report on the ethical questions regarding scientific research and submit it to the Second Chamber this autumn. This report will be used to prepare a framework for new research developments. The central point will be how far man can attempt to change the natural order and in how far genetic manipulation should be allowed.

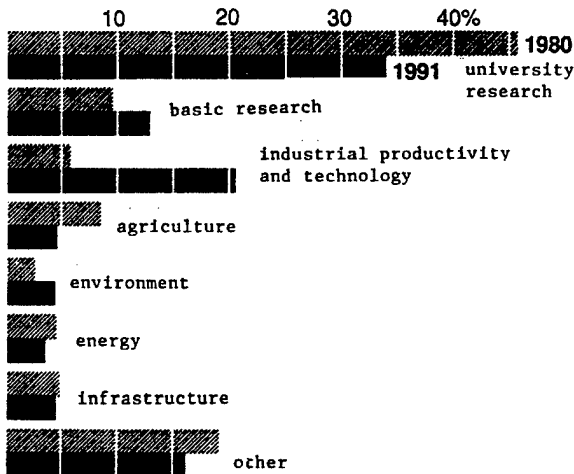

Distribution of Dutch expenditure for research and development in respectively 1980 and 1991.

CORPORATE ALLIANCES

JESSI Approves Joint European Wafer-Scale Memory Project

91P60030P Berlin MIKROPROZESSORTECHNIK in German Oct 90 p 36

[Text] The joint project for developing solid-state intermediate memory devices for high-performance computers, involving Anamartic Ltd., Bull S. A. and Siemens, has now received the support of the JESSI [Joint European Submicron Silicon Initiative] project. This type of memory is based upon an architecture encompassing an entire silicon wafer and termed wafer-scale architecture.

Quite often, conventional hard and floppy disks are not fast enough for minicomputers and workstations. Wafer-scale technology offers a solution, since solid-state intermediate memories utilizing an entire silicon wafer can be realized on the basis of this technology. The same process is used for microstructure manufacture as for 4- and 16-Mbit dynamic memories. Specially developed hard- and software make it possible to create a network of memory cells, extending over an entire silicon wafer, in which defective zones are automatically detected and bypassed. Compared to intermediate memories consisting of individual components, the improved reliability [of the new memories] makes it possible to realize cost savings of 35 percent.

Alliance Between Fiat, France's CGE Detailed

91MI0031X Rome AIR PRESS in Italian 10 Oct 90 p 2363-2364

[Text] Fiat and CGE, one of France's major private industrial groups, have announced a strategic alliance at the international level that will involve an exchange of shareholdings, a streamlining of industrial activities through a series of mergers, and the establishment of a joint European holding company to develop projects in areas of common interest. As part of the agreement, Fiat will buy about 6 percent of CGE's stock, corresponding to 6.4 million shares. The operation will include existing portfolio shares and convertible bonds to be issued by Alcatel NV. In this way Fiat will become one of CGE's major shareholders. CGE will acquire about 3 percent of Fiat's stock, that is 45 million ordinary shares for a total of about 450 billion lire. The operation will include portfolio shares and a convertible stock loan in portfolio shares. In this way CGE will become one of Fiat's major shareholders. Representatives of both groups will be on both companies' boards of directors and a strategic committee will also be established to increase long-term cooperation.

In the telecommunications sector, it has been decided to concentrate the activities of Alcatel Face and Telettra (which is 90 percent owned by the Fiat group). Fiat will acquire a 25 percent share in the new group in addition to the abovementioned 6 percent share in CGE. Telettra

has been valued at approximately 2.5 trillion lire. With this operation, Alcatel, which is already a world leader in the development and manufacture of telecommunications systems will also become a world leader in cable and radio-link transmissions. In turn, Telettra will play a special role in the Alcatel group thanks to its R&D resources in the field of transmissions.

As far as industrial activities in the components sector are concerned, CGE will give Fiat 50.1 percent of the CEAc (European Accumulator Company which includes the Chloride Motive Power and ATSA-Tudor companies) group's capital and will retain its 48 percent share. CEAc operates in the sector of accumulators and lead batteries primarily for the automotive industry. Fiat, which was already involved in this activity with Magneti Marelli, will thus acquire a leading role among European manufacturers. Furthermore, agreements are currently underway to give 50.1 percent of Fiat Ferroviaria to the GEC-Alsthom joint venture (a world leader in the railway industry, and 50 percent owned by CGE). Fiat will keep its 49.9 percent share in Ferroviaria which therefore becomes part of a primary international concern. The Fiat and CGE joint communique mentions the establishment of a jointly-owned European holding company to promote interests and initiatives in common high-technology areas as another important aspect of the agreement between the two companies. In particular, the priority areas which have been identified comprise: composite materials, artificial intelligence, and new telecommunications services applied to the transport industry. By the end of the year, all these operations will become a series of agreements to be submitted to the competent authorities.

CORPORATE STRATEGIES

Leading German Machine Tool Manufacturer To Offer CIM Components

91WS0052A Coburg MASCHINE & WERKZEUG
in German No 21, Oct 90 pp 28-30

[Unattributed article: "Shop-Oriented CIM Component Supplier: 'No Longer Just Machine Tools'"; first paragraph is MASCHINE & WERKZEUG introduction]

[Text] At this year's CEBIT [annual trade fair in Hannover] in , Gebr. Hoffmann Werkzeugmaschinen AG & Co. KG [Hoffmann Brothers Machine Tools], which no longer considers itself merely a machine tool supplier but rather a "partner of industry in all production issues including the organizational environment," was represented for the first time by a booth. At CEBIT an important part of the company's new design was introduced: The section for CIM [Computer-Integrated Manufacturing Components].

This year for the first time, the well-known machine tool supplier Gebr. Hoffmann was represented by its own booth at Hannover's CEBIT trade show. According to the word at the show: "That fact alone makes it clear that

we are not simply one of the largest machine tool marketing firms in the Federal Republic of Germany, but that we also consider ourselves a supplier of shop-oriented CIM components." Furthermore, at Hannover they wanted to provide some insight into the new company design developed in light of the dramatic changes in East and West Europe.

Founded in 1948, and therefore currently in its 42d year of existence, Gebr. Hoffmann Werkzeugmaschinen AG & Co. KG is, by its own account, among the leading sellers of machine tools in the Federal Republic of Germany.

New Company Design Introduced

Annual sales are approximately 150 million German marks [DM] and 200 employees. Since 1965 the company has belonged to Kloeckner & Co. of Duisburg, the "large European sales and service company which has the necessary financial background for our specialized business." A significant share of the machines sold by Gebr. Hoffmann come from the GDR. This year sales of GDR machines will amount to approximately DM40 million; in 1991, the figure will be almost DM50. Purchase agreements covering that amount were concluded at this year's Spring Trade Show in Leipzig just before CEBIT. The company's new design is based on the following premises:

- As the European internal market develops, even small and medium-sized companies will be forced to increase the level of automation of production for the high salaried Federal Republic of Germany to be able to compete internationally.
- The investment lag in the GDR will lead, after establishment of economic and monetary union, to a surge in demand for numerically controlled machine tools and CA [computer assisted equipment] technologies.
- The GDR machine tool companies represented by Gebr. Hoffmann and their products will continue to exist under the conditions of a market economy. After economic and monetary union or merger of the two parts of Germany these companies will be increasingly accepted as German machine manufacturers, i.e., they will lose their former "COMECON [Council for Mutual Economic Assistance] image."
- The solution of the customer-oriented problems of the future—such as shorter door-to-door times, higher flexibility of production, increasing quality requirements, and greater variety — lies for the metal processing industry in the gradual introduction of CIM components.

The word at CEBIT was that this scenario has led at Gebr. Hoffmann to a group of concrete measures: Thus, at the beginning of the year a specialized section was set up for production automation and customer-specific global solutions. This is an engineering department that

analyzes individual customer specifications and bids and delivers for automation projects incorporating the CNC [computer numeric controlled] series production machines already marketed.

"To constantly meet increasing technical demands," four additional specialized sections have been formed:

- the section for the metal removing technologies of drilling and milling,
- the section for the metal removing technologies of lathing, grinding, and gear tooth forming,
- the section for erosion technologies,
- the section for CIM components.

In the area of goods and services, Gebr. Hoffmann no longer considers itself a mere machine tool supplier, but rather a "partner of industry" in all issues of metal removing production techniques including electron discharge machining and the organizational environment at the shop and production preparation levels.

This new perception of its identity is now to be made more apparent to customers through a "modern corporate design." This is further evident in the slogan accompanying the new company logo: It no longer reads "Machine Tools" but rather "Technologies." This year's CEBIT in Hannover gave the company the opportunity to introduce one of the important parts of the new company design: The section for CIM components.

"CIM Components Demonstrated"

"We are," it was explained at CEBIT, "dedicated followers of the philosophy of 'CIM from the bottom up', i.e., starting at the shop level." This naturally falls within the customer base found primarily in small and medium-sized industry. For these companies PPS [Primary Power Supply] systems with their economies of material and time are still too "sluggish" to meet the needs for customer-oriented fine tuning of production. Therefore, in this area, the prevailing idea at present is to first introduce two automation links which are currently affordable and readily understandable, namely the CAD/CAM [computer aided design/computer aided manufacturing] connection and the shop communication system.

The products "Pacemaker" and "Manager" offer ideal systems for gradual introduction of CIM structures which can later be integrated into higher networks and systems—PPS, for example. However, even without the PPS link, the "Pacemaker" and "Manager" systems lead to a significant improvement of the production cycle through faster communication and elimination of data media such as paper tapes and lists. The ratio of door-to-door time to production time, which normally runs four to one, is significantly improved through the transparency of the production process.

Additionally, better quality is obtained through incorporation of CAQ [computer aided quality control] stations into the shop network. In view of the EC guidelines for product liability on the one hand and the requirement of

the automobile industry for documented quality certificates on vendor parts on the other, even the medium-sized company cannot do without CAQ. Consequently, the new CAQ component from Gebr. Hoffmann was the center of attention at the CEBIT show.

Philips Announces Reorganization Measures

Further Job Cuts

91WS0064A Rotterdam NRC HANDELSBLAD
in Dutch 25 Oct 90 pp 1, 13

[Text] Eindhoven, 25 Oct—Another 35,000 to 45,000 jobs must be eliminated at Philips worldwide by 1992. This is to take place by improving efficiency in every part of the company. This decision comes on the heels of the reorganization measures in the Components and Information Systems divisions that will cost 10,000 jobs.

Philips president J.D. Timmer made this announcement this morning while presenting the results of the third quarter.

Another unknown number of jobs will be eliminated at Philips through a shutdown of activities.

Top management at Philips intends to decide before the end of this year which of the inadequately profitable parts of the company will be sold or shut down.

As a result of this "penetrating" process of "portfolio choices," the company will probably have to increase once again the 2.7 billion guilders that the concern plans to set aside for restructuring measures. This would mean an automatic increase in the estimated 1990 loss of two billion guilders. Timmer said that he could easily pass on assumption of the losses to 1991, but that he has no need to do so.

Of the 2.7 billion guilders that Philips had earmarked for restructuring measures, 2.25 billion was spent in the second quarter on reorganizing the Components and Information Systems divisions. Because of this, the concern had to accept a loss of 2.15 billion during the third quarter. If the restructuring measures are left out of the equation, the operating result for the third quarter was 522 million guilders, 70 million less than in the previous year.

Drs. H.H.A. Appelo, the financial expert on the Philips Group Board, said that there is "a certain stabilization of the operating result." "The results are low, much too low. But there was no further worsening during the last quarter," Appelo declared.

Philips sales declined by 1 percent over the first 9 months of 1990 to 39.47 billion guilders. This was primarily the result of exchange rate fluctuations and cutbacks in European defense activities. If these are left out of the equation, sales increased by 7 percent.

The only improvement in the operating result over the first nine months was seen in the Consumer Products

sector (audio, video, small household appliances, music): from 818 to 1122 million guilders.

In the Lighting (lamps), Professional Products and Systems (computers, telephone switchboards, medical systems, industrial systems) and Components (chips, cathode-ray tubes) sectors, the operating result declined.

In the Lighting sector, traditionally Philips' cash cow, the result dropped by nearly half, to 399 million guilders. The Professional Products and Systems sector suffered a shortfall of 48 million guilders, primarily due to sharp losses in the Information Systems division, losses that could not be adequately offset by better results in the medical systems and industrial systems divisions.

Given the major losses this year and the concern's poor financial position, the top management at Philips has decided not to pay a dividend for 1990. This signifies a break with a long tradition. Over the past 10 years, that dividend was always two guilders, which at present would correspond to nearly 10 percent of the value of Philips stock.

Timmer said that he regards 1991 as "a transitional year." He declared that "the first improvements must be discernible in 1992." However, he refused to make any predictions about profits.

In the past, Philips has carried out drastic reorganizations on a highly regular basis, the last time being three years ago under the leadership of Timmer's predecessor, C.J. van der Klugt. At the time, van der Klugt as well spoke of "a transitional year," after which a rich harvest would follow in 1990.

The fundamental difference compared to earlier intervention, Timmer said, is that these measures will be borne to a much greater extent by Philips' top stratum. "This is not something that I have imposed by memo. All top managers are aware that this plan must succeed."

Timmer said that all the top managers at Philips "have subjected themselves to a process of critical self-examination. The central questions here: Do we not have much too much dead weight, are we not going off on tangents much too much, are we not simply making things unnecessarily complicated. All established notions are up for discussion," Timmer said. "That demands great courage to effect change."

'Operation Centurion' Launched

*91WS0064B Rotterdam NRC HANDELSBLAD
in Dutch 30 Oct 90 p 1*

[Article by Dick Wittenberg: "Blueprint for New Philips Style"]

[Text] Eindhoven, 30 Oct—Personal contracts for executives, a reduction in the asphyxiating bureaucracy, and introduction of a new realism. These are some of the main elements of Operation Centurion, the campaign

that president J.D. Timmer has launched to introduce a new style of working at Philips.

The text of the blueprint for the operation, a sort of new Philips catechism, printed in its entirety in today's NRC HANDELSBLAD, provides detailed insight into the new management style that Timmer envisages.

Operation Centurion is the foundation for the reorganization measures announced last week that will cost 35,000 to 45,000 of the company's 286,000 jobs by 1992. Operation Centurion is also the basis for the next phase of reorganization, whereby parts of the company that chronically operate at a loss will be shut down.

Centurion is in fact a large-scale communication and training program intended to impress the company's new principles upon all executives and to ensure that all employees are pursuing the same goals. Members of the Group Board will be present in person at the consciousness-raising sessions for the top 2,000 employees in the company. The intention is that the 2,000 top managers translate the central messages and guidelines to their own organizations and convey them to their subordinates.

Most of the principles and guidelines contained in the Centurion blueprint are simple, very obvious, and not new, not even for Philips. What is new is the consistency with which a broad package of fundamental assumptions is being introduced across the board within the company. Also new is the large number of management strata involved in this process of change.

Principles of 'Operation Centurion'

*91WS0064C Rotterdam NRC HANDELSBLAD
in Dutch 30 Oct 90 p 14*

[Text] Eindhoven, 30 Oct—A system of rewards and punishment for managers who do or do not keep agreements, strong decentralization, more selective handling of available resources. These are some of the basic assumptions for a new Philips culture, as it is termed in the blueprint for Operation Centurion, the large-scale campaign to get Philips back on sound footing.

Centurion is in fact a large-scale communication and training program comprising five parts: Communication, Training, Budgeting, Support, and Evaluation. The program began on 9 August with a meeting for the top management, and will continue until the middle of next year.

Because the mobilization campaign is the focal point of the reorganization operation at Philips, the following is the word-for-word text of the new Philips catechism.

Centurion

The only goal of Operation Centurion is quite simply to increase profitability. This means holding our performance in the following areas up to the light on a worldwide scale:

1. Activities Portfolio

- Make activities that chronically operate at a loss or at a mediocre performance level profitable again. If this is not possible, get out of that activity.
- Increase support for smaller but carefully selected, promising product lines.
- Greater selectivity in new acquisitions.
- Reduce vertical integration (i.e., do less yourself, delegate more, Ed.)
- Strive for cooperative arrangements.

2. Assets Management

- Improve employee productivity.
- Increase the capital turnover rate.
- Reduce the amount of capital tied up in fixed assets, accounts receivable, inventories.

3. Product Creation Process

- Identify and specify our core technologies.
- Careful and concentrated allocation of resources for research and development and a balanced selection of goals for the short and long term.
- Greater process efficiency and effectiveness; i.e., how can we create a competitive advantage, what are the most striking characteristics of the product, how can we speed up the process, what will it cost?
- Provide for coupling (cross-links between business unit (a company element responsible for a certain activity, Ed.) and product division).

4. Quality

- Quality must become a mindset and an integral part of the value system within the company.
- Quality is not achieved in isolation, nor through ad hoc efforts by individuals.
- Quality is a campaign that must penetrate to every corner of the company to excel in everything that we do.
- Quality is the most important factor defining profitability.
- Customer satisfaction, product design satisfaction, functionality, and reliability through delivery discipline and after-sale service are the most important measures of quality.

5. Organization and Management

- Organizational Principles

The basic assumption is decentralization. Each management stratum must add value, it must offer a clear perspective, and it must make a clearly distinguishable contribution.

The business unit is the basic building block. Within the policy guidelines, the business units have responsibility for managing their operations, based on the agreed specific goals.

Management at the level of the product division adds value to the business units by combining the industrial perspective with specific skills and shared concern resources, for the sake of a large group of users: consumers, office personnel, technicians, medical staff, etc.

The Group Board adds value by providing the perspective of a worldwide electronics company with a clear vision of the future. It does this by developing certain broad skills and resources and by strengthening the chances for success for its product divisions and its business units.

On each level, value is added in principle in three ways:

Operational Management.

Business units must find methods for improving their operational performance, whereby they are guided by experience in the industry and successful operational approaches.

Future-Oriented Management.

Resources are allocated to parts of the company in accordance with their potential for growth and profits, whereby—if necessary—consideration is given to establishing new company units, engaging in takeovers, entering into joint ventures, and shutting down company units.

Interlinkage Management.

Identify and guide the most important links crossing through product divisions and business units by determining strategic directions for the company and by stimulating the development of vital skills.

Bureaucracy

It follows that staff divisions at headquarters and in product divisions and national organizations should be as small as possible. Marketing and sales divisions in the national organizations are among the company's most important assets. Although they are a component of the organization formed by the product division and the corresponding business units, they must be afforded the room to operate as independently as possible, protected against bureaucratic meddling from headquarters.

- Managers are judged on the basis of the degree to which they succeed in living up to agreements.

The company urgently needs a stricter application of accounting principles. The budget will form the basis for

a personal contract for managers, a contract that also contains a system of rewards and punishment. Thus, in the future settling accounts on the basis of performance will be the most normal thing in the world for managers. This will mean keeping your word by living up to promises.

- The Spirit of the Organization

The worldwide electronics market seems like a battlefield of competing forces. The intensity of the competition is enormous. Being successful thus requires great motivation, a clear vision of the future, and, most of all, the will to win. The company's current problems are no excuse for defeatism. Nor should they be viewed as a threat. We must regard them as a challenge and mobilize and apply our extensive resources accordingly. This demands great involvement via communication. Our troops must be told what they are fighting for and what is at stake.

Above all, we must all fight bureaucracy. Philips' bureaucracy has penetrated so far into all elements of the company that we have unconsciously adapted our attitude to it. Bureaucracy is a waste of time and money, it stifles initiative, and it blocks anyone who dares stick his neck out.

We must learn to be more outwardly focused. More aware of the world around us. More aware of the behavior and strategies of our competitors. We must be proud of our technical achievements and at the same time assume a new feeling of realism. We cannot do everything. Nor do we have the greatest financial reserves in our branch of industry.

And last, but certainly not least: We must reduce our tolerance as far as mistakes are concerned and be less inclined to put the blame on someone else, or even to attribute it to an "act of God." The most important thing is that we tackle the current problems quickly and with resolve. It is important to see a light at the end of the tunnel, but premature, reassuring statements must be avoided.

If we develop more care for the Philips concern, that will stimulate creativity and action.

EAST-WEST RELATIONS

British-Hungarian Joint Venture's Expansion Plans Described

*91WS0055C Budapest NEPSZABADSAG in Hungarian
15 Oct 90 p 5*

[Article by Zsuzsa Szekeres: "Germany, USA, Hungary"]

[Text] The SZKI [Computer Technology Research Institute and Innovation Center] Recognita Company was formed in November of last year. The share of the SZKI in the British-Hungarian joint venture is 59 percent, that

of Walters Europe is 31 percent, and workers' shares makeup the remaining 10 percent. The initial personnel numbered 28 persons. The November-December turnover of the firm last year came to 36 million forints; the after taxes profit, after paying dividends, was 5.6 million forints. For the first two months the joint stock company paid a time proportional 35 percent dividend.

They plan receipts of 150 million forints for this year and as of the end of August they had overfulfilled the time proportional portion of this. The vast majority of the receipts came from export of the optical character recognition program Recognita sold on the market of developed industrial countries.

Eight Thousand Plus'es Sold

During the life of the product they sold more than 8,000 copies of Recognita Plus. They sold nearly 5,000 copies in the past 11 months, 1,500 of which were the new 1.1 version. Distributors in nearly 30 countries are marketing it. Europe represents the chief market; it is especially popular in the Scandinavian countries, in Germany, Switzerland, and Austria and most recently in Great Britain, the Benelux states, and Spain. As business director Benedek Tallai said, Recognita Plus is the biggest seller of all European OCR [Optical Character Reader] programs.

Following German unification the market share of the former GDR also must be brought up to the West German level; therefore, on 27 June, three days before the foreign exchange union, an enterprise called Recognita Buroautomatisierung GmbH Leipzig was registered in conjunction with two private East German persons and a firm in which Siemens had an interest (VEB Nachrichtenelektronik). The share of the SZKI Recognita Company in this is 60 percent. They recognized a real demand as the first deal of the new enterprise is expected to realize a gross profit of 120,000 marks by the end of the year.

Overseas Plans

"The market of the United States of America is a great challenge for us," said Benedek Tallai, turning to plans and tasks for the future. The general meeting decided to found an enterprise in the United States, with 100 percent ownership and significant base capital, probably on 1 January 1991. It will handle both local sales and local research and development. They hope to conquer 10-15 percent of the American OCR market within two years.

The newest 1.1 version of Recognita Plus appeared in August; it better recognizes separated and run together letters and so can be used even with weak quality printing. This version can compete with the best OCR programs in speed, flexibility and the number of systems supported and in the precision of recognition for English letters. The program supports 27 text editors and is also capable of reading horizontal format documents (tables,

etc.). It is a weakness of the Recognita Company, however, that it does not offer a solution for Macintosh. There are good OCR programs for these computers, primarily in the USA.

Speaking of their marketing policy, the business director said that they regularly participate in the American Comdex and the Hannover CeBit; every two years they participate in the Systems exhibit in Munich and their vendors are obliged to participate in national exhibits, for which they are offered aid if needed.

Only 150 At Home

Recognita has not sold nearly as well in Hungary as it has in Western European countries. The total sales are around 150. The customers include the Paks Nuclear Power Plant Enterprise, the Postal Experimental Institute and the State Accounting Office. For a mass conquest of the market there is need for scanners offered at a competitive price. For this reason the Recognita Company has signed distributor's contracts with Microtech, Sharp and Hewlett-Packard and has an agreement with Pentax and Fujitsu.

Cheap DTP [Design to Price] software was lacking also, so the company is offering a Hungarian version of the Finesse electronic publications editor of the Swiss Logitech firm, at a price of 40,000 forints. (They also undertake to edit publications as a service.) If needed they offer a complete solution, with computer and laser

printer. Their efforts show that the firm considers the Hungarian market especially important, not least of all because a direct exchange of experiences with users contributes to the continual development of the product.

Former GDR To Produce Siemens Computers

*91P60029P Berlin MIKROPROZESSORTECHNIK
in German Oct 90 p 3*

[Text] In a basic agreement, the data systems engineering and information technology sector of Siemens AG, Berlin and Munich, and the newly established Computer Elektronik Dresden (CED) agreed to collaborate in hardware development and manufacture. By 1992, an annual production volume of around 400 million deutsche marks shall have been achieved.

Thus, CED GmbH, formerly ROBOTRON Elektronik Dresden (RED) will execute contracts for hardware development. The production of Siemens computers of the MS-DOS, SINIX and BS200 product lines began in October [of this year], once a guarantee of a high quality standard was obtained. PCD-2 personal computers, SINIX MX300 multiuser computer systems and the 7.500-H60 central processing unit (CPU) will be manufactured under license. Work will begin with the retrofitting of outmoded 7.560/BS2000 CPUs.

Initial deliveries are slated for late 1990. Product sales will be carried out through existing Siemens sales outlets or new distributing enterprises, for the GDR, the USSR and other East European countries.

22161Z

SPRINGFIELD, VA
5285 PORT ROYAL RD
ATTN: PROCESS 103
NTIS

6
22161

This is a U.S. Government publication. Its contents in no way represent the policies, views, or attitudes of the U.S. Government. Users of this publication may cite FBIS or JPRS provided they do so in a manner clearly identifying them as the secondary source.

Foreign Broadcast Information Service (FBIS) and Joint Publications Research Service (JPRS) publications contain political, military, economic, environmental, and sociological news, commentary, and other information, as well as scientific and technical data and reports. All information has been obtained from foreign radio and television broadcasts, news agency transmissions, newspapers, books, and periodicals. Items generally are processed from the first or best available sources. It should not be inferred that they have been disseminated only in the medium, in the language, or to the area indicated. Items from foreign language sources are translated; those from English-language sources are transcribed. Except for excluding certain diacritics, FBIS renders personal and place-names in accordance with the romanization systems approved for U.S. Government publications by the U.S. Board of Geographic Names.

Headlines, editorial reports, and material enclosed in brackets [] are supplied by FBIS/JPRS. Processing indicators such as [Text] or [Excerpts] in the first line of each item indicate how the information was processed from the original. Unfamiliar names rendered phonetically are enclosed in parentheses. Words or names preceded by a question mark and enclosed in parentheses were not clear from the original source but have been supplied as appropriate to the context. Other unattributed parenthetical notes within the body of an item originate with the source. Times within items are as given by the source. Passages in boldface or italics are as published.

SUBSCRIPTION/PROCUREMENT INFORMATION

The FBIS DAILY REPORT contains current news and information and is published Monday through Friday in eight volumes: China, East Europe, Soviet Union, East Asia, Near East & South Asia, Sub-Saharan Africa, Latin America, and West Europe. Supplements to the DAILY REPORTs may also be available periodically and will be distributed to regular DAILY REPORT subscribers. JPRS publications, which include approximately 50 regional, worldwide, and topical reports, generally contain less time-sensitive information and are published periodically.

Current DAILY REPORTs and JPRS publications are listed in *Government Reports Announcements* issued semimonthly by the National Technical Information Service (NTIS), 5285 Port Royal Road, Springfield, Virginia 22161 and the *Monthly Catalog of U.S. Government Publications* issued by the Superintendent of Documents, U.S. Government Printing Office, Washington, D.C. 20402.

The public may subscribe to either hardcover or microfiche versions of the DAILY REPORTs and JPRS publications through NTIS at the above address or by calling (703) 487-4630. Subscription rates will be

provided by NTIS upon request. Subscriptions are available outside the United States from NTIS or appointed foreign dealers. New subscribers should expect a 30-day delay in receipt of the first issue.

U.S. Government offices may obtain subscriptions to the DAILY REPORTs or JPRS publications (hardcover or microfiche) at no charge through their sponsoring organizations. For additional information or assistance, call FBIS, (202) 338-6735, or write to P.O. Box 2604, Washington, D.C. 20013. Department of Defense consumers are required to submit requests through appropriate command validation channels to DIA, RTS-2C, Washington, D.C. 20301. (Telephone: (202) 373-3771, Autovon: 243-3771.)

Back issues or single copies of the DAILY REPORTs and JPRS publications are not available. Both the DAILY REPORTs and the JPRS publications are on file for public reference at the Library of Congress and at many Federal Depository Libraries. Reference copies may also be seen at many public and university libraries throughout the United States.