

ARMY RESEARCH LABORATORY



Inspecting for Corrosion of Shipboard Conduits and Shield- to-Ground Adapters with Low- Bandwidth Pulsed-Current Injection

by John E. B. Tuttle

ARL-MR-354

December 1997

The findings in this report are not to be construed as an official Department of the Army position unless so designated by other authorized documents.

Citation of manufacturer's or trade names does not constitute an official endorsement or approval of the use thereof.

Destroy this report when it is no longer needed. Do not return it to the originator.

Army Research Laboratory

Adelphi, MD 20783-1197

ARL-MR-354

December 1997

Inspecting for Corrosion of Shipboard Conduits and Shield- to-Ground Adapters with Low- Bandwidth Pulsed-Current Injection

John E. B. Tuttle

Sensors and Electron Devices Directorate

sponsored by

Naval Sea Systems Command

2531 Jefferson Davis Highway

Arlington, VA 22242-5160

Abstract

We inspected metal conduit with a low-bandwidth, pulsed-current injection. This technique, called the L/R method, has been used successfully to identify corroded cable shields on aircraft, armored vehicles, and fixed and mobile communications systems. We successfully applied this technique to the inspection of shipboard electromagnetic protective conduit. The application of this technique is described in detail and the experimental results are presented.

Contents

1. Introduction	1
2. Background	1
3. Summary	2
4. Concept Description—Conduit Screening by the L/R Method	4
4.1 <i>Measuring Resistance</i>	4
4.2 <i>Measuring Risetime</i>	6
4.3 <i>Detecting Flaws</i>	6
5. Procedure and Results	6
6. Application of Screening Criteria and Results	10
7. Detecting Flaws—Data and Discussion of Results	10
8. Conclusions and Recommendations	11
Distribution	13
Report Documentation Page	15

Figures

1. Measurement of cable shield resistance, disconnection not required	5
2. Waveform of injected current with loop and with loop and 0.025- Ω resistor	5
3. Measurement of total cable shield path resistance in a system, disconnection not required ...	5
4. Method 1 (L/R method) measurement of exterior conduit current	7
5. Method 2 measurement of exterior and interior currents	7
6. Response of INMARSAT antenna conduit to L/R method: waveform of current for outer shield and inner conductor	8
7. Response of forward SSR-1 antenna shield-to-ground adapter to L/R method: waveform of current for outer shield and inner conductor	8
8. Response of starboard URT-23 antenna shield-to-ground adapter to L/R method: waveform current for outer shield and inner conductor	9
9. Response of port URT-23 control conduit to L/R method: waveform current for outer shield and inner conductor	9
10. Response of cutout switch conduit to L/R method: waveform current for outer shield and inner conductor	9
11. Sensor output versus sensor position near a flaw: block diagram and sensor output	11
12. INMARSAT antenna and flawed conduit	12
13. Flaw-detection sensor outputs from flawed area of INMARSAT antenna conduit (see fig. 12): ahead of flaw, at flaw, and past flaw.	12

Table

1. Composite results of inspection tests aboard USNS Mohawk	2
---	---

1. Introduction

The Navy's surface fleet has a problem with salt corrosion of stuffing tubes and shield-to-ground adapters through which cables and wiring are routed above and below ship decks. These tubes and adapters are metallic conduits that shield wires and cables from varying sources of electromagnetic interference on board ships. The sources of such interference include radar and radio transmitters, which may interfere with computers and other electronic equipment. Salt corrosion degrades the shielding provided by the stuffing tubes and shield-to-ground adapters; thus, continuous inspection and repair are necessary. These conduits are covered by a protective coating, which makes visual inspection impossible. The Naval Sea Systems Command (NAVSEA) has issued a call for technologies that can facilitate frequent inspection and readily identify degraded shields.

2. Background

The U.S. Army Research Laboratory (ARL) competed in a proof-of-concept test held on board the United States Navy Ship (USNS) *Mohawk* between 27 and 30 March 1995. The purpose of the test was to evaluate various approaches to the inspection of shipboard conduits and shield-to-ground adapters. Five competing approaches for inspecting shipboard conduits were tested and evaluated for NAVSEA by the Naval Surface Weapons Command (NSWC) at Dahlgren, Virginia. The five competing approaches and their advocating organizations are listed below.

1. Wideband pulsed-current injection—NSWC.
2. Injected damped sine (2 MHz)—Ogden Government Services.
3. Shield cable tester (SCT)—TRW.
4. Repetitive, low-bandwidth pulsed-current injection (L/R test set)—ARL.
5. Portable x-ray inspection—S.W. Engineering Associates/Sandia.

Each competitor was given a list of selected conduits and shield-to-ground adapters to test so that data obtained by each method could be compared for common test points. The standard of comparison was to be the ratio of outer-shield current to inner-conductor current. These criteria could be easily applied for approaches 1 through 4. Approach 5 (x-ray) located flaws directly; thus data obtained by this method could not readily be compared to data obtained by approaches 1 through 4. However, the L/R tester, enhanced by a unique surface current sensor, was able to detect and locate the flaws detected by the portable x-ray machine, as well as perform the conduit shield-to-ground adaptor inspections.

3. Summary

The ARL team used the L/R test set to test 22 conduits and/or shield-to-ground adapters with two test methods to distinguish between good and corroded conduits. Method 1, referred to as the L/R method, requires access to only the exterior portion of the conduit; L/R measures total shield path resistance and the risetime of the current pulse induced on the conduit. From these two measurements, the grossly flawed shields can be quickly identified. Method 2 requires access to both exterior and interior portions of the conduit; with this method, a ratio (expressed in decibels) of outer-shield to inner-conductor current is measured. The results obtained by a combination of the two methods were 4 good conduits and/or shield-to-ground adapters and 18 corroded conduits and/or adapters.

Because neither method alone is sufficient to properly identify all defective conduits or shield-to-ground adapters, both methods should be used. Thus, a tabulation of results should include total shield path resistance and the ratio of outer-shield to inner-conductor currents. The risetime measurement, obtained from the L/R method, is helpful but is not mandatory. Detailed results are in table 1.

In addition to identifying good and corroded adapters, the L/R test set, enhanced by the addition of a flaw-detection sensor, located flaws in three conduits. These flaws were confirmed by the portable x-ray machine.

Table 1. Composite results of inspection tests aboard USNS Mohawk.

Designation	Test point	Current R (Ω)	Risetime t_r (μ s)	I_{EXT}/I_{INT} (dB)	Result
INMARSAT antenna (conduit)	No number assigned	0.028	75	21.0	Rejected
Television antenna shield ground adapter	15	0.114	50	38.4	Accepted
SSR-1 antenna shield ground adapter					
Starboard	26	0.021	50	26.0	Accepted
Port	27	0.034	50	14.0	Rejected
Forward	25	0.016	50	34.0	Accepted
URT-23 antenna shield ground adapter					
Starboard	21	0.038	50	14.4	Rejected
Port	19	0.052	80	6.0	Rejected
URT-23 control (conduit)					
Port	18	0.192	20	41.8	Rejected
Starboard	20	0.80	40	4.0	Rejected
Forward telephone URC-80 transceiver shield ground adapter	1	0.048	50	26.0	Accepted

Table 1. Composite results of inspection tests aboard USNS Mohawk (cont'd).

Designation	Test point	Current R (Ω)	Risetime t_r (μ s)	I_{EXT}/I_{INT} (dB)	Result
X-band radar antenna	35	1.2	80	No measurable current found	Rejected
Cutout switch (conduit)	37	1.0	80	No measurable current found	Rejected
S-band radar antenna	33	0.25	100	1.6	Rejected
Cutout switch (conduit)	36	0.137	160	1.06	Rejected
Aft telephone power outlet	38	0.63	40	No measurable current found	Rejected
NAVTEX antenna	—	Open	—	No measurable current found	Rejected
Watch receiver antenna	—	Open	—	No measurable current found	Rejected
ALDEN FAX OA-100 four-whip antenna 10-1	—	Open	—	No measurable current found	Rejected
Global positioning system	—	Open	—	No measurable current found	Rejected
Ray Nav. 6000 LORANC antenna 4-3	—	Open	—	No measurable current found	Rejected
Cellular telephone antenna 10-4	—	1.25	10	No measurable current found	Rejected
Naval Mark 22CA antenna 10-2	15A	0.62	20	No measurable current found	Rejected

4. Concept Description—Conduit Screening by the L/R Method

A brief description of the L/R technique follows. For clarity, we divide the discussion into two subtopics, according to the functions performed:

1. Conduit/shield-to-ground adapter screening by the L/R method.
2. Location of faults by L/R exciter and flaw-detection sensor method.

Although the L/R test set successfully obtained outer-shield to inner-conductor current ratios with method 2 (see sect. 5, fig. 5), we do not discuss that function here.

For method 1, two basic L/R measurements are taken in order to distinguish good from corroded conduits. The two measurements are shield path resistance (ohms) and risetime (microseconds) of the pulsed-current injections.

4.1 Measuring Resistance

The L/R tester can measure total path resistance and individual resistances within the path and (when necessary) locate an open junction. Resistances in the range of 0.003 to 2.0 Ω can be measured without the conduit being disconnected. The tester excites the shield of a cable from a repetitively pulsed (25-Hz), long-duration (200- μ s), magnetic field to measure the resulting induced current. An inductive coupler and coupler driver is the source of the magnetic excitation. An inductively coupled current probe measures the current. The present L/R tester requires a user-furnished portable oscilloscope, from which the desired measurement from a continuously displayed waveform can be extracted. The waveform displayed will usually show the voltage proportional to the induced cable current.

Where individual resistances within the cable shield path must be measured, two waveforms must be observed: total path current and voltage across two points (i.e., connector junctions) suspected of having a high resistance. The desired resistance measurements are obtained from scope deflection (V_p) in volts, transfer impedance (Z_t) of the current probe, and the known constant of the inductive-coupler/coupler-driver combination. For the L/R tester described here, the constant is $E_i = 0.2$ V, which is an equivalent voltage source inserted into the circuit under test by the action of the magnetic excitation.

Measurement of the resistance of a conduit or shield-to-ground adapter circuit by the L/R method can best be understood by reference to figures 1, 2, and 3. Figure 1 shows a bench experiment in which the L/R test set is connected to a closed loop made of coaxial cable. Figure 2 shows the waveform of the injected current under two test conditions: the loop alone and the loop with a 0.025- Ω resistor inserted. Figure 2 shows that inserting the 0.025- Ω resistor into the loop reduces the amplitude of the loop current by a ratio of 6 to 1.

Figure 1. Measurement of cable shield resistance, disconnection not required (a bench test to demonstrate sensitivity of L/R test set).

(John E. B. Tuttle, "Inspection of cable shield in situ without disconnection," Proceedings of the 15th International Aerospace and Ground Conference on Lightning and Static Electricity, Atlantic City, NJ, 6-8 October 1992.)

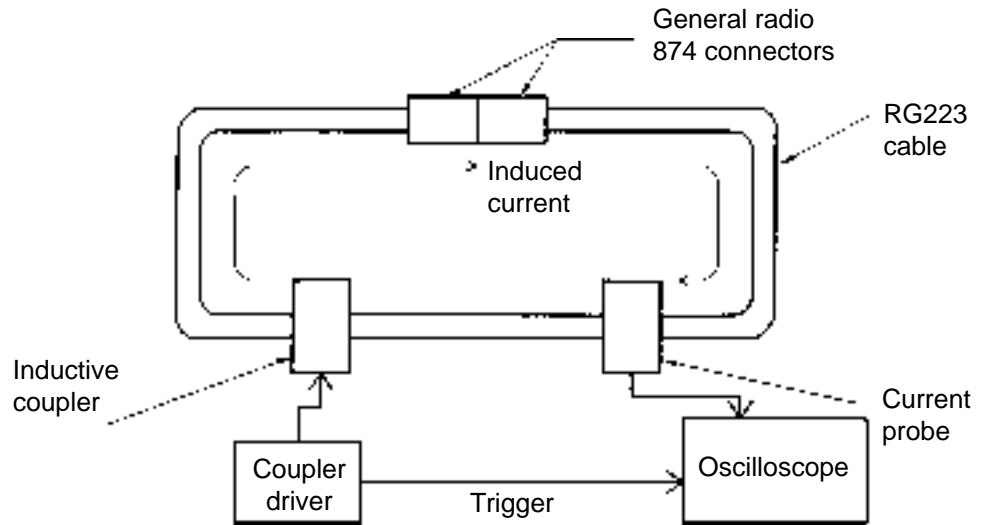

Figure 2. Waveform of injected current (a) with loop and (b) with loop and 0.025-Ω resistor.

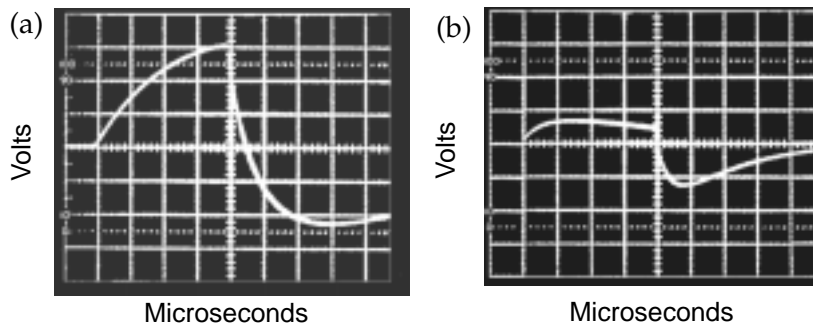
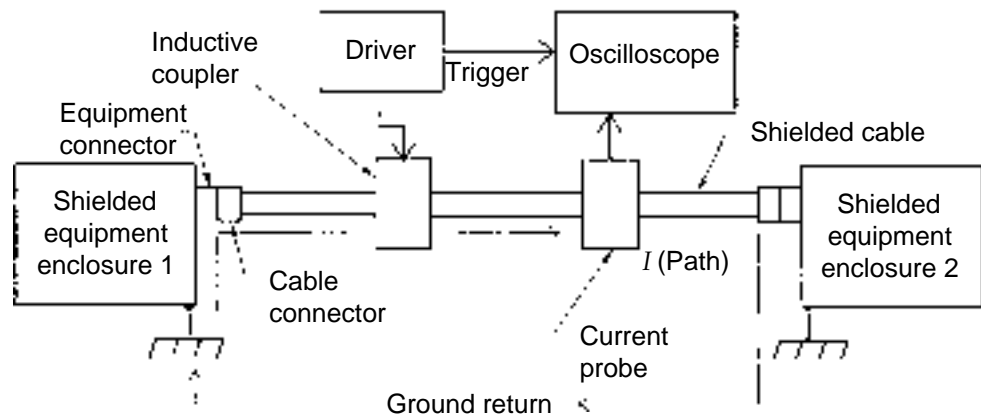

Figure 3. Measurement of total cable shield path resistance in a system, disconnection not required.

(John E. B. Tuttle, "Inspection of cable shield in situ without disconnection," Proceedings of the 15th International Aerospace and Ground Conference on Lightning and Static Electricity, Atlantic City, NJ, 6-8 October 1992.)



The methods for computing total shield path resistance and for measuring individual junction resistances are presented in figure 3. Resistance is calculated from the peak amplitude of the displayed waveform (V_{peak} in volts), the transfer impedance of the current probe (Z_t in ohms), and the known constant voltage (E_i) inserted into the path by the injection probe and solid-state driver.*

*The method and apparatus are protected by U.S. Patent No. 5,391,991, Cable Shield Resistance Test Set.

4.2 Measuring Risetime

In situ inspection of shipboard conduits by the L/R method is based primarily on measurement of resistance and secondarily on measurement of injected pulse risetime. Measurement of resistance alone is usually not sufficient. While high values of shield path resistance ($R_{SH} > 0.2 \Omega$) clearly indicate a degraded shield, low values ($R_{SH} \leq 0.05 \Omega$) may mask gross defects. Low values of shield path resistance have been measured where shield-to-ground adapters have been “floating” or ungrounded. This type of fault can be easily recognized by measurement of the risetime of the injected current pulse. Risetimes longer than $50 \mu\text{s}$ indicate that the response is governed not by the conduit but by the cables supposedly shielded by the conduit. At the other extreme, risetimes less than $20 \mu\text{s}$ indicate a highly resistive conduit, which would be obvious from measurement of shield resistance. The measurement of risetime provides a qualitative means for interpreting the meaning of measured resistances. Where method 2 can be applied (see sect. 5, fig. 5), risetime measurement becomes less important.

4.3 Detecting Flaws

Detecting flaws is another capability of the L/R test set. Nonresistive flaws (i.e., semicircular slots) on the surface of a cable shield or conduit and, in some cases, flaws below the surface of a shield can be detected. The flaw-detection sensor employs the current-injection probe (coupler) and solid-state driver of the L/R test set to excite the conductor under test, and a special purpose surface-current sensor to detect the local magnetic field near the flaw. The output of the sensor, after amplification, is displayed by the oscilloscope. As the sensor moves along the length of a conduit under excitation, its output changes abruptly as it moves toward and away from the flaw. The surface-current sensor, constructed from physically small high-value inductance coils, responds to current flowing perpendicular to the direction of the injected current while rejecting the effects of the much stronger injected current.*

5. Procedure and Results

We inspected shipboard conduits and shield-to-ground adapters as illustrated in figures 4 and 5. Waveforms of current for both exterior shields and interior conductors were filmed with oscilloscope cameras. Although more than 50 waveforms were filmed, only representative ones are presented here. The inspection results are presented in table 1. Pass/fail decisions are also included in table 1; these decisions are based on the application of two criteria:

- low resistance, $R \leq 0.15 \Omega$, and
- high outer-shield to inner-conductor current ratio, $I_{EXT}/I_{INT} \geq 25 \text{ dB}$.

*A detailed description of the flaw-detection method and sensor is in patent disclosure ARL 94-17, Cable Shield Fault Locator.

Figure 4. Method 1 (L/R method) measurement of exterior conduit current.

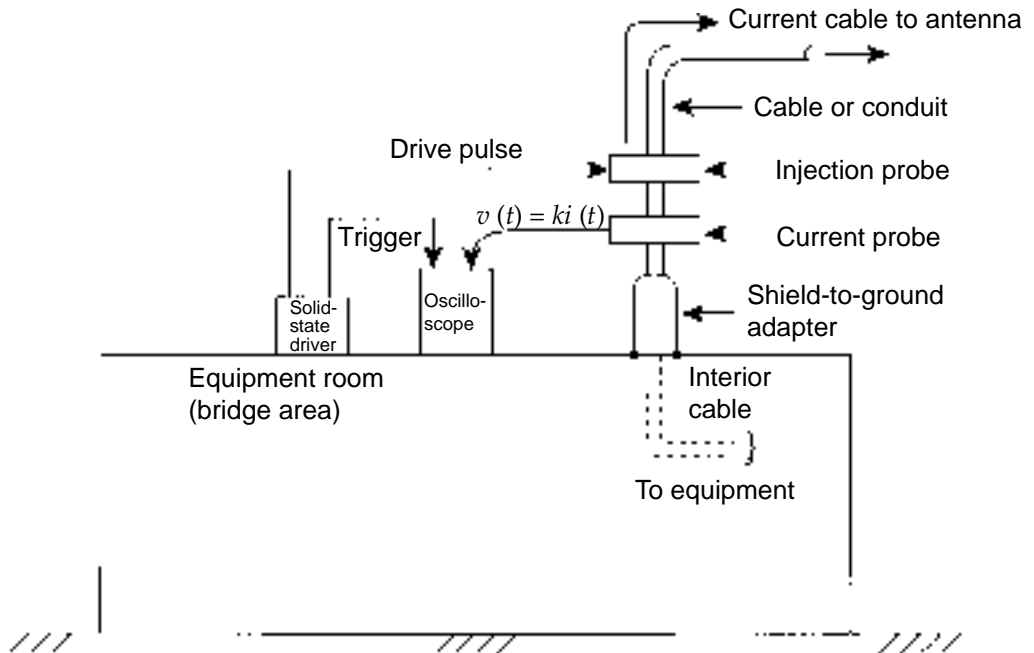
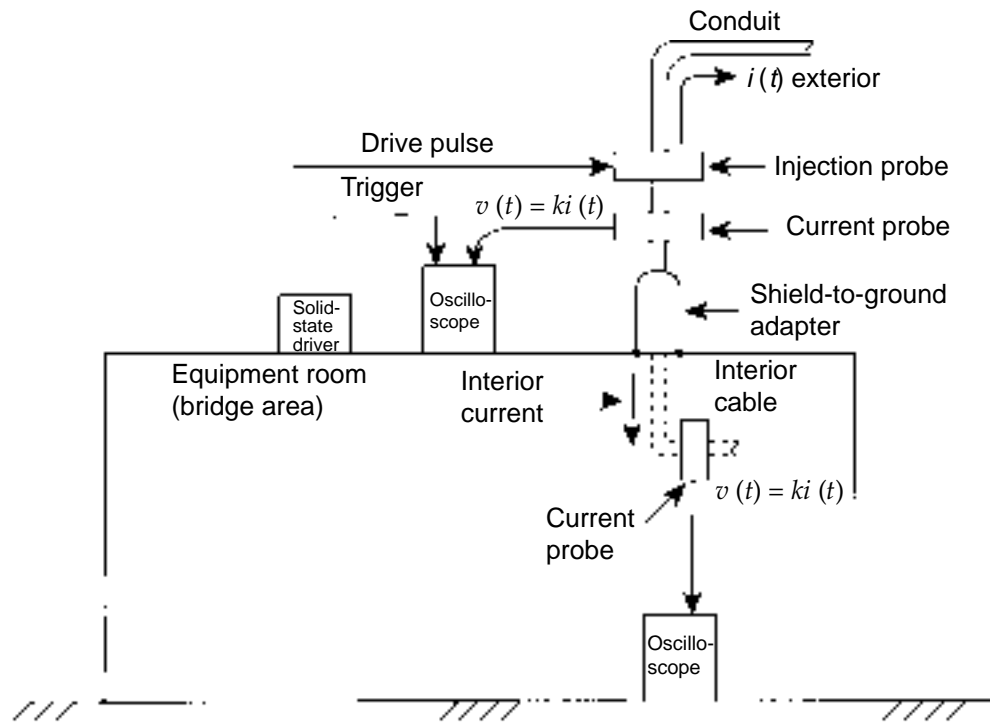

Figure 5. Method 2 measurement of exterior and interior currents.



If one or both of these criteria are not met, the conduit under test is corroded. The rationale for these proposed criteria is discussed in section 6.

Current-time waveforms, representative of those obtained from the test inspections, are presented in figures 6 through 10.

Figure 6 shows the waveforms of current obtained for the outer shield (fig. 6 (a)) and inner conductor (fig. 6 (b)) of the International Maritime

Satellite (INMARSAT) antenna conduit. Based on the criteria we propose and the long risetime ($t_r \approx 75 \mu\text{s}$), we must reject this conduit. This decision is reinforced by visual inspection of the conduit ends (showing pitting and corrosion), x-ray photographs, and detection of a flaw in the conduit by the flaw-detection sensor (see sect. 7).

Figure 7 shows the waveforms of current obtained for the outer shield (fig. 7 (a)) and inner conductor (fig. 7 (b)) of the forward secondary surveillance radar (SSR)-1 antenna shield-to-ground adapter (test point 25). Based on the proposed criteria, this adapter is accepted.

Figure 8 shows the waveforms of current obtained for the outer shield (fig. 8 (a)) and inner conductor (fig. 8 (b)) of the port URT-23 shield-to-ground adapter (test point 21). Based on the proposed criteria, this adapter is rejected.

Figure 9 shows the waveforms of current obtained for the outer shield (fig. 9 (a)) and inner conductor (fig. 9 (b)) of the port URT-23 control conduit (test point 18). Based on the proposed criteria, this conduit is rejected.

Figure 10 shows the waveforms of current obtained for the outer shield (fig. 10 (a)) and inner conductor (fig. 10 (b)) of the cutout switch conduit (test point 36). Based on the proposed criteria and the excessively long risetime ($t_r \approx 100 \mu\text{s}$), this conduit is rejected.

Figure 6. Response of INMARSAT antenna conduit to L/R method: waveform of current for (a) outer shield and (b) inner conductor.

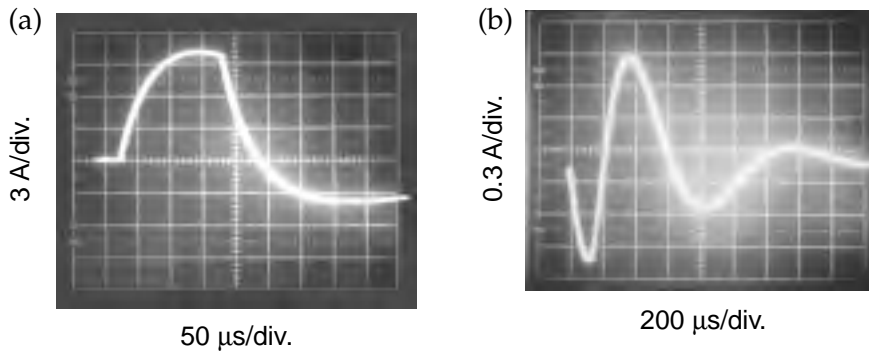

Figure 7. Response of forward SSR-1 antenna shield-to-ground adapter to L/R method: waveform of current for (a) outer shield and (b) inner conductor.

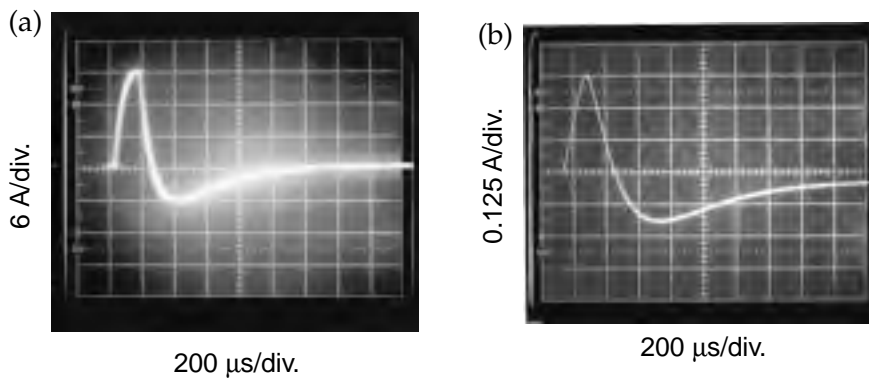

Figure 8. Response of starboard URT-23 antenna shield-to-ground adapter to L/R method: waveform current for (a) outer shield and (b) inner conductor.

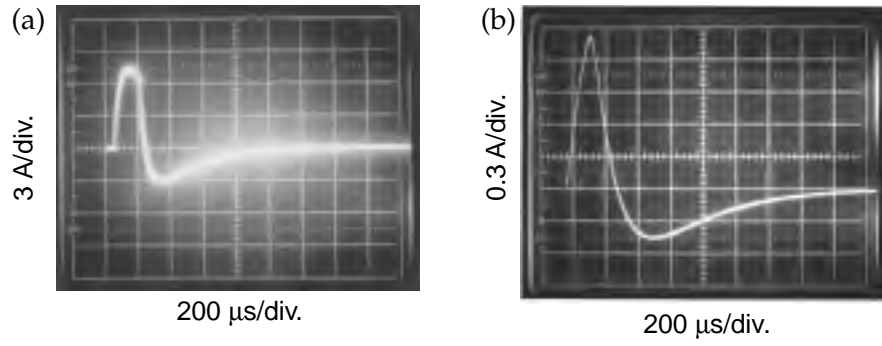

Figure 9. Response of port URT-23 control conduit to L/R method: waveform current for (a) outer shield and (b) inner conductor.

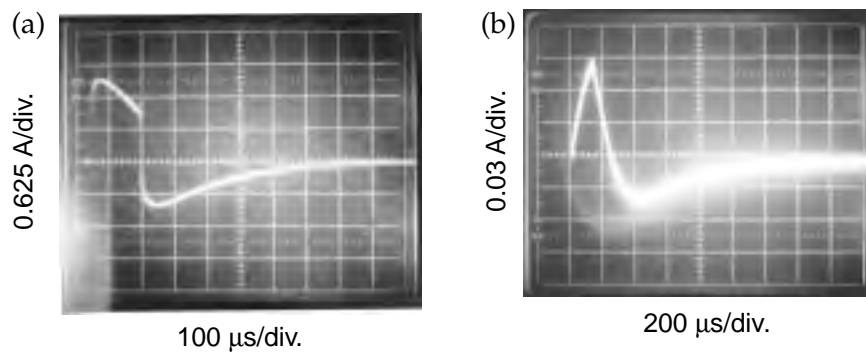
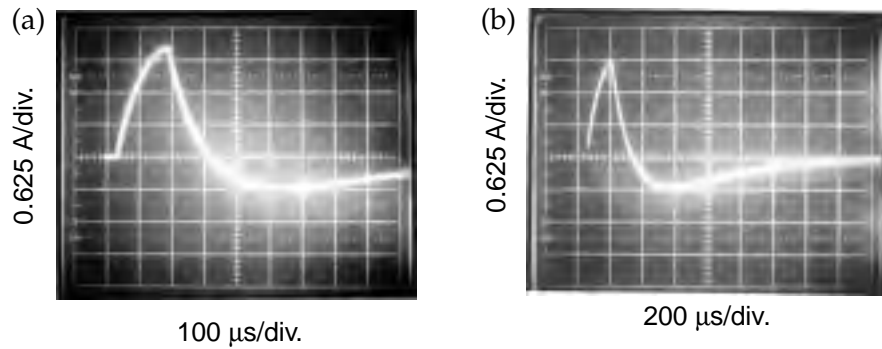

Figure 10. Response of cutout switch conduit to L/R method: waveform current for (a) outer shield and (b) inner conductor.



Note: risetime \approx 160 μ s

6. Application of Screening Criteria and Results

For proper screening of conduits and shield-to-ground adapters so that good units are accepted and corroded units are rejected, we had to take measurements from both the L/R method and method 2. As previously stated, low resistance alone is not sufficient for screening conduits. Low resistance may be attributable to low-resistance paths within the confines of an open or highly resistive shield. Sample waveforms obtained from such shields are shown in figures 6, 8, and 10. These shields appear to have both low resistance and low outer-shield to inner-conductor current ratios. The relatively high measured value of shield current would seem to indicate low resistance. However, a very high outer-shield to inner-conductor current ratio alone is not sufficient for determining whether to accept or reject a conduit; the low inner-conductor current may be due to a high resistance path within the confines of a highly resistive or open shield. This case is illustrated by the waveforms of figure 9. The results of applying the two criteria to the screening of conduits and shield-to-ground adapters are presented in table 1.

7. Detecting Flaws—Data and Discussion of Results

The location of flaws in conduits by the fault-detection sensor is illustrated in figure 11. Current is injected into the conduit under test according to the previously described L/R method, the sensor traverses the length of the conduit, and the amplified sensor output is continuously displayed by the oscilloscope. The amplified sensor output changes slowly over the length of the conduit until the sensor approaches the flawed area; sensor output abruptly increases ahead of the flaw, decreases to near zero directly over it, and abruptly increases as the sensor moves away from the flaw. These variations in sensor output with distance from the flaw are illustrated in figure 11 (b). This pattern was recorded for three conduits, including the INMARSAT antenna conduit; x-ray photographs that were subsequently taken of the detected flaws validated this fault-detection technique. A sketch of the INMARSAT antenna and the flaw in the conduit is shown in figure 12. Figure 12 also shows three sensor positions in relation to the flaw. In figure 13, three film frames of waveforms around the defected flaw are presented for the INMARSAT antenna conduit; these waveforms correspond to the three sensor positions in relation to the flaw given in figure 12. Subsequent x-ray photographs of the detected flaw revealed a broken wire within the conduit that was constructed of spirally wound metal.

The model flaw-detection sensor is constructed on a 1.5 × 1.5 in. circuit card, which does not cover the entire 360° of the conduit cross section. The purpose of the flaw-detection experiments on board the *Mohawk* was not to demonstrate a finished product but to demonstrate the concept. The present model works well for straight and curved runs of spirally

Figure 11. Sensor output versus sensor position near a flaw: (a) block diagram and (b) sensor output.

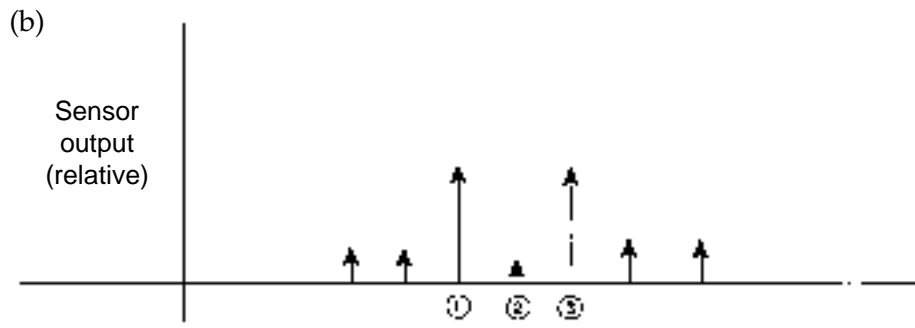
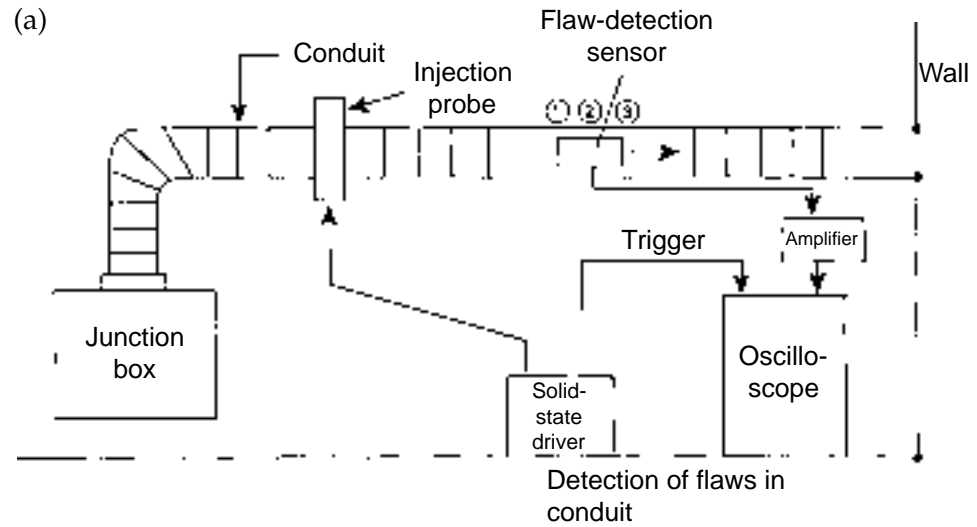

1. Sensor reading of current ahead of flaw.
2. Sensor reading of current at flaw.
3. Sensor reading of current past flaw.

wound conduit but is unsatisfactory for junctions at the surface of boxes and bulkheads; flaws at these places can be located by other L/R techniques. The thickness of the protective coating at the boundary of a conduit and its box prevents the placement of the sensor close enough to the junction for adequate sensor output to be obtained.

8. Conclusions and Recommendations

The low-bandwidth, pulsed-current injection technique (L/R method), augmented by the cable shield flaw-detection sensor, compares favorably with the other four competing techniques evaluated aboard the USNS *Mohawk*. Degraded conduits and shield-to-ground adapters can be readily identified with the L/R technique alone. When the L/R test set is augmented by the cable shield flaw-detection sensor, the location of a cable shield flaw can be readily found; furthermore, defects in interior wire bundles may also be found. The interior wire defects, such as broken wires, are readily located where the conduit is constructed of spirally wound metal.

Figure 12. INMARSAT antenna and flawed conduit.

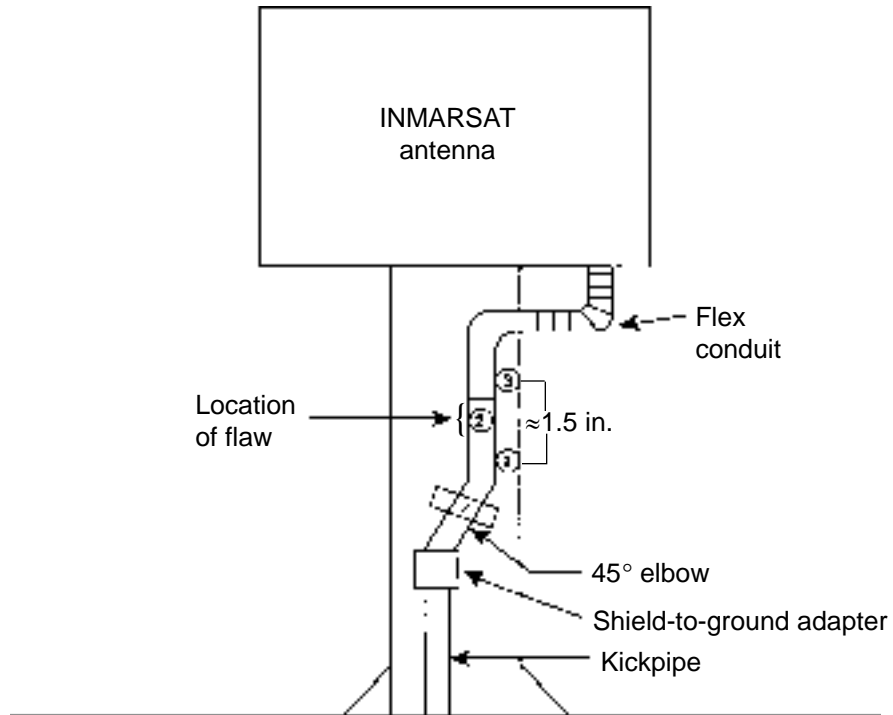

1. Sensor reading of current ahead of flaw—see figure 13(a).
2. Sensor reading of current at flaw—see figure 13(b).
3. Sensor reading of current past flaw—see figure 13(c).

Figure 13. Flaw-detection sensor outputs from flawed area of INMARSAT antenna conduit (see fig. 12): (a) ahead of flaw, (b) at flaw, and (c) past flaw.

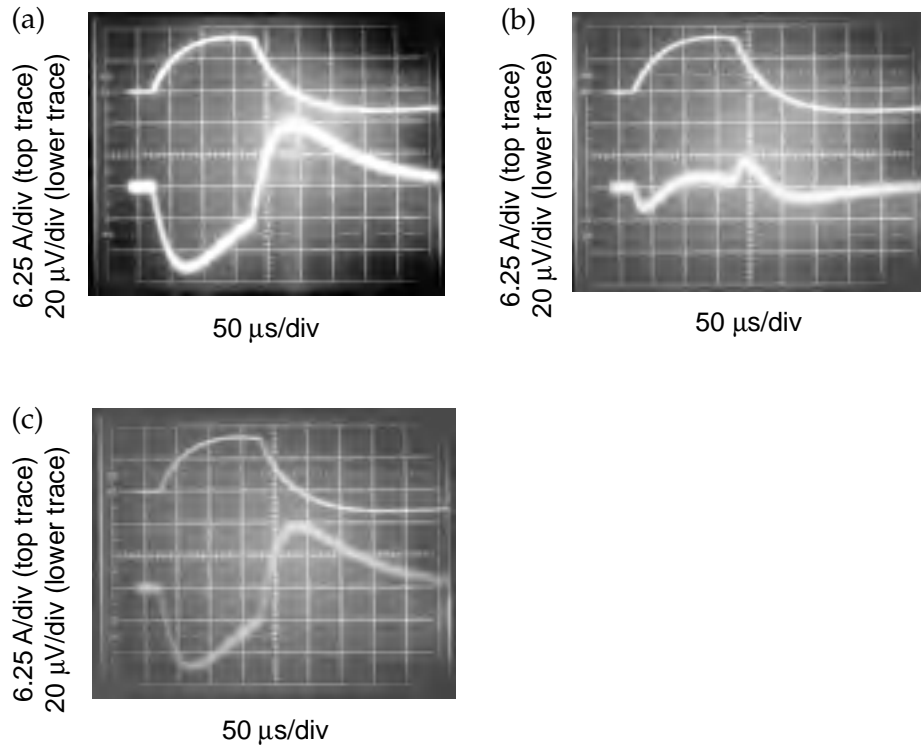

Distribution

Admnstr
Defns Techl Info Ctr
Attn DTIC-OCP
8725 John J Kingman Rd Ste 0944
FT Belvoir VA 22060-6218

Hdqtrs Dept of the Army
Attn DAMO-FDQ D Schmidt
400 Army Pentagon
Washington DC 20310-0460

US Military Academy
Dept of Mathematical Sci
Attn MAJ D Engen
West Point NY 10996

Nav Sea Sys Cmnd
Attn 03K2B J Juras
Attn 03K2I D Cross
2531 Jefferson Davis Hwy
Arlington VA 22242-5160

Nav Surface Weapons Cmnd
Attn Code J54 G Brackett
Attn Code J54 N Stetson
Dahlgren div
Dahlgren VA 22448-5100

Anteon Corp
Attn M Craig
2341 Jefferson Davis Hwy Ste 400
Arlington VA 22202

US Army Rsrch Lab
Attn AMSRL-CI-LL Tech Lib (3 copies)
Attn AMSRL-CS-AL-TA Mail & Records
Mgmt
Attn AMSRL-CS-AL-TP Techl Pub (3 copies)
Attn AMSRL-SE-DS J Tuttle (10 copies)
Adelphi MD 20783-1197

REPORT DOCUMENTATION PAGE			<i>Form Approved</i> OMB No. 0704-0188	
Public reporting burden for this collection of information is estimated to average 1 hour per response, including the time for reviewing instructions, searching existing data sources, gathering and maintaining the data needed, and completing and reviewing the collection of information. Send comments regarding this burden estimate or any other aspect of this collection of information, including suggestions for reducing this burden, to Washington Headquarters Services, Directorate for Information Operations and Reports, 1215 Jefferson Davis Highway, Suite 1204, Arlington, VA 22202-4302, and to the Office of Management and Budget, Paperwork Reduction Project (0704-0188), Washington, DC 20503.				
1. AGENCY USE ONLY (Leave blank)		2. REPORT DATE December 1997	3. REPORT TYPE AND DATES COVERED Final, from March to April 1995	
4. TITLE AND SUBTITLE Inspecting for Corrosion of Shipboard Conduits and Shield-to-Ground Adapters with Low-Bandwidth Pulsed-Current Injection			5. FUNDING NUMBERS DA PR: A140 PE: 62120A	
6. AUTHOR(S) John E. B. Tuttle				
7. PERFORMING ORGANIZATION NAME(S) AND ADDRESS(ES) U.S. Army Research Laboratory Attn: AMSRL-SE-DS (etuttle@msc.arl.mil) 2800 Powder Mill Road Adelphi, MD 20783-1197			8. PERFORMING ORGANIZATION REPORT NUMBER ARL-MR-354	
9. SPONSORING/MONITORING AGENCY NAME(S) AND ADDRESS(ES) Naval Sea Systems Command 2531 Jefferson Davis Highway Arlington, VA 22242-5160			10. SPONSORING/MONITORING AGENCY REPORT NUMBER	
11. SUPPLEMENTARY NOTES AMS code: 622120.H40 ARL PR: 7NEYYY				
12a. DISTRIBUTION/AVAILABILITY STATEMENT Approved for public release; distribution unlimited.			12b. DISTRIBUTION CODE	
13. ABSTRACT (Maximum 200 words) <p>We inspected metal conduit with a low-bandwidth, pulsed-current injection. This technique, called the L/R method, has been used successfully to identify corroded cable shields on aircraft, armored vehicles, and fixed and mobile communications systems. We successfully applied this technique to the inspection of shipboard electromagnetic protective conduit. The application of this technique is described in detail and the experimental results are presented.</p>				
14. SUBJECT TERMS inductive coupled low-resistance testing			15. NUMBER OF PAGES 20	
			16. PRICE CODE	
17. SECURITY CLASSIFICATION OF REPORT Unclassified	18. SECURITY CLASSIFICATION OF THIS PAGE Unclassified	19. SECURITY CLASSIFICATION OF ABSTRACT Unclassified	20. LIMITATION OF ABSTRACT UL	