



**FOREIGN
BROADCAST
INFORMATION
SERVICE**

JPRS Report

Soviet Union

FOREIGN MILITARY REVIEW

No 8, August 1989

9980123 217

REPRODUCED BY
U.S. DEPARTMENT OF COMMERCE
NATIONAL TECHNICAL INFORMATION SERVICE
SPRINGFIELD, VA. 22161

20340

5 5
5 5
2
20340
35
DIA
RTS-2D
WASHINGTON, DC

DTIC QUALITY INSPECTED 3

DISTRIBUTION STATEMENT A

Approved for public release;
Distribution Unlimited

Soviet Union
FOREIGN MILITARY REVIEW
 No 8, August 1989

JPRS-UFM-90-001

CONTENTS

18 January 1990

[The following are translations of selected articles from the Russian-language monthly journal ZARUBEZHNOYE VOYENNOYE OBOZRENIYE published in Moscow by the Ministry of Defense. Refer to the table of contents for a listing of any articles not translated.]

GENERAL PROBLEMS, ARMED FORCES

U.S. Military-Political 'Competitive' Strategy [N. Ruzayev; pp 3-8]	1
Japan's Military-Political Command and Control Entities [A. Rusanov; pp 8-13]	5
U.S., South Korean Armed Forces Exercise Team Spirit-89 [B. Maksimov; pp 14-16]	9

GROUND FORCES

U.S. Army Separate Armored Cavalry Regiment [A. Volodin; pp 17-23]	10
Program for Upgrading the U.S. AH-64A Apache Combat Helicopter [V. Nelin; pp 24-26]	18
Field Artillery Target Acquisition Radars [V. Savrasov; pp 26-30]	20

AIR FORCES

New Things in Combat Training of USAF SAC Air Forces [A. Alekseyev; pp 31-35]	22
Electromagnetic Pulse of a Nuclear Burst and Protecting Electronics Against It [D. Figurovskiy; pp 35-41]	25

NAVAL FORCES

Antisubmarine Mine Weapons [Yu. Pelevin, V. Surnin; pp 45-52]	29
U.S. Navy Future Missile Cruiser Project [B. Poyarkov; pp 52-54]	34
Basic Specifications and Performance Characteristics of Torpedoes of Navies of Capitalist Countries [Yu. Yurin; pp 55-60]	36

MILITARY ECONOMICS, INFRASTRUCTURE

Greece's Military Industry [V. Surkov; pp 61-68]	41
Dutch Civil Defense [V. Yemelyanov; pp 68-73]	45
New Depleted Uranium Production Plant [P. Apagoshin; p 74]	49
Belgian Center for Unexploded Chemical Ordnance Disposal [V. Elin; p 74]	49

REPORTS, EVENTS, FACTS

U.S. 1st Cavalry Division (Armored) [I. Vanin; p 75]	50
NATO Allied Forces Exercise in the Baltic Approaches [V. Zelenov; pp 75-76]	50
Development of the U.S. C-17 Military Transport Aircraft [Yu. Pavlenko; p 77]	51
Subcaliber Canister Projectiles for the Mk 7 Gun Mount [V. Nikolayev; p 77]	51
New Aircraft for the French Navy [A. Gladkov; p 78]	52
Articles Not Translated from ZARUBEZHNOYE VOYENNOYE OBOZRENIYE No 8, August 1989	52
Publication Data	53

FOREIGN MILITARY REVIEW

No 8, August 1989

GENERAL PROBLEMS, ARMED
FORCES

U.S. Military-Political 'Competitive' Strategy

904Q0001A Moscow ZARUBEZHNOYE
VOYENNOYE OBOZRENIYE in Russian
No 8, Aug 89 (signed to press 23 Aug 89) pp 3-8

[Article by Col N. Ruzayev]

[Text] *A new military-political "competitive" strategy¹ was worked out in the United States in the latter half of the 1980's within the scope of a process of developing a conceptual approach to national security questions. The thesis of the inevitability of a protracted U.S. political, military, economic and ideological confrontation with the Soviet Union was made the basis of foreign policy conditions for its realization. Domestic reasons dictating its acceptance were the significant federal budget deficit and in this connection the need for a certain limitation on an increase in expenditures while keeping them at a high level. In addition, the 1980's are characterized by rapid development of applied military technologies and the creation of new models of weapons and combat equipment which substantially influence methods of combat employment of combat arms and branches of the Armed Forces. The Defense Department leadership resorted to management science methods tested and worked out over decades of stiff competitive struggle, with the objective of optimizing the planning of military organizational development.*

BASIC PROVISIONS. The essence of the proclaimed strategy is to give priority in planning the development of future arms to those directions which should ensure not only attainment of U.S. military superiority, but also the Soviet Union's profound economic exhaustion while taking advantage of U.S. S&T successes to the maximum extent.

It is necessary to note that ideas which were made the basis of "competitive" strategy also had been advanced earlier in one form or another. Back in 1972 A. Marshall, an associate of the Rand Corporation and now director of the U.S. Defense Department Office of Net Assessment, suggested using management principles and above all the cost-effectiveness criterion in the process of military planning.² The economic aspect of confrontation with the Soviet Union also is not new. It was essentially present in all stages of the arms race unleashed by the United States following World War II. What is fundamentally new in strategic planning using provisions of "competitive" strategy is its reliance on the latest achievements of science and technology and technological advantages which the United States believes it has achieved in a number of areas. In essence it is a question of developing the arms race at a qualitatively different level.

Consequently the traditional methods of realizing U.S. military-force thinking are being supplemented by new ones. In describing the strategy of "competition," USSR Minister of Defense Army Gen D. T. Yazov emphasized that it means "drawing the USSR and other Warsaw Pact countries into military competition with the West again. Reliance is being placed on the latest technologies, by which it is proposed to depreciate our existing systems of arms and military equipment and force us to switch funds from socioeconomic programs to the development of new weapons. And since the strategy's authors knowingly imply our lag in the sphere of technology, according to their calculations such weapons ultimately will be ineffective and thus a maximum strategic preponderance³ over the USSR will be assured."

"Competitive" strategy was promulgated for the first time in 1986 by Secretary of Defense C. Weinberger and since then has been an inalienable element of U.S. policy.

Development of offensive weapon systems is considered the most advisable within the framework of this strategy inasmuch as, according to the concept of American strategists, in order to create counterweapons the USSR will be forced to draw on considerable physical and human resources for developing strictly defensive weapon systems, thereby weakening its offensive and counteroffensive potential.

Practical realization of "competitive" strategy is based on a comprehensive assessment and forecasting of the Soviet Union's actions in response to new American weapon programs as well as on the planning of Washington's answering steps. As then U.S. Secretary of Defense F. Carlucci declared in January 1989, the methodology of applying "competitive" strategy presumes a thorough check of possible variants of the development of events "three moves ahead" according to the principle: our action—USSR counteraction—U.S. countercounteraction. From the very beginning planning here must be aimed at neutralizing the USSR's possible retaliatory steps.

A theoretical elaboration of the foundations of the new strategy was completed on the whole by mid-1987, after which the Pentagon moved on to the stage of its practical implementation. In this connection a "competitive strategy" policy council headed by the Secretary of Defense, a council executive committee and, as the working body, a "competitive strategy" policy department on the Secretary of Defense staff were created within the Defense Department organization (see diagram). Intelligence support to the "competitive" strategy was assigned to a special intelligence committee. Special working groups are formed (for a period up to 90 days) from specialists of all branches of the Armed Forces to resolve specific problems.

The military situations simulation committee also was formed with the objective of checking working group recommendations. It plays out different variants of

Support entities for realizing "competitive" strategy in the U.S. Defense Department

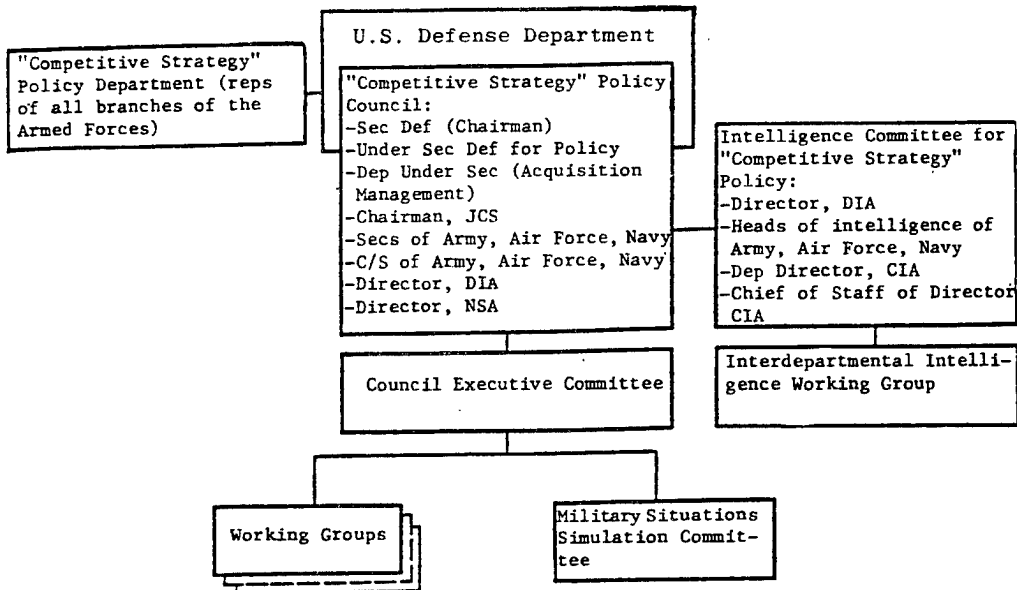

particular situations of a military-political, military, military-technical and military-economic character on models using computers. The council adopted a decree that every proposal for developing a new weapon model must contain a substantiation of its advisability from the standpoint of "competitive" strategy.

CHOICE OF BASIC DIRECTIONS OF ARMS DEVELOPMENT IN ACCORDANCE WITH "COMPETITIVE" STRATEGY In determining the main directions of military-technical policy for the next 20 years, the Pentagon leadership takes into account one of the key demands of "competitive" strategy: maintaining and widening the existing gap between the United States and USSR in the sphere of development of basic technologies. According to American strategists' calculations, this should place the Soviet Union face to face with the need for a cardinal redistribution of resources in directions unfavorable for it and force it to maintain a high level of military expenditures, thereby economically exhausting it and achieving a decisive U.S. military superiority.⁴

Based on this, promising basic directions of research were determined where the United States allegedly has a substantial technological preponderance over the USSR which must be maintained and increased. They include in particular stealth technology, developments in the sphere of superconductivity and new structural materials, creation of fifth-generation computers (supercomputers) and creation of target identification and automated data processing equipment.⁵

It is planned to ensure U.S. technological superiority over the USSR by conducting scientific research with a so-called high technical level of risk above all in those areas where the Americans estimate that they have a

clear superiority. It is believed that a negative research result does not bear the threat of a U.S. lag, while success will permit a qualitative leap which can lead to an irreversible breakaway according to the Pentagon leadership's concept.

In the strategic offensive forces the air component of the triad⁶ will see the most dynamic development inasmuch as, in the opinion of military experts, it is in this sphere that the technological preponderance achieved by the United States can be used most effectively. Cruise missiles with conventional and nuclear warheads and the B-2 bomber made with stealth technology are considered especially promising strategic air weapons from the standpoint of "competitive" strategy as well as based on conditions of operational-strategic employment.

According to the American estimate, the accelerated development of cruise missiles is dictated above all by purely military reasons. Pentagon specialists proceed from the assumption that this is the only effective component of strategic offensive forces which permits conducting a protracted all-out conventional war. Cruise missiles made with stealth technology also can be used in a surprise attack with nonnuclear weapons against strategic targets on USSR territory. In addition, the calculation is that the Soviet Union will have to undertake considerable expenditures in reorganizing its air defense system to be sufficiently effective against cruise missiles. The AGM-129A (ACM) nuclear cruise missile made with stealth technology is to become operational in the early 1990's. High guidance accuracy will permit using it with a conventional warhead to distances of 2,300-2,500 km with appropriate modifications. It is also planned to develop a nonnuclear LRCCM cruise missile based on stealth technology with a guidance accuracy of around 3 m.

The primary cruise missile platforms are to be the B-52 and B-1B bombers up to the year 2000, and from the mid-1990's also the B-2 aircraft made with stealth technology. In the assessment of American specialists, its use will considerably increase strategic aviation's capabilities of penetrating the Soviet Union's air defense.

The chief direction for ICBM development is an increase in accuracy which, with warhead yields remaining the same, substantially increases the probability of destroying hardened and small strategic targets and essentially ensures creation of a first-strike potential in the United States. It is believed that the MX ICBM, Trident II SLBM and possibly the Midgetman ICBM will ensure fullest accomplishment of these missions.

In the strategic defensive forces use of "competitive strategy" principles was displayed most vividly in the SDI program, which is aimed above all at creating and maintaining a U.S. breakaway from the USSR in key technology areas and at using the results for developing new weapon models in the interests of all branches of the Armed Forces. With regard to an ABM system, U.S. military-political leaders give preference for now to a point system of ground-based ballistic missile defense. It is proposed to make a final decision on the advisability of practical realization of a specific SDI program option after studying results of developments and thoroughly analyzing possible asymmetric countermeasures on the Soviet Union's part.

Formation of a unified air defense system for the North American continent which has been given the name "antiaircraft defense initiative" is one direction in the development of strategic defensive forces. From the standpoint of "competitive" strategy it is assigned the mission of creating effective systems for engaging future Soviet air attack weapons, above all cruise missiles, and thus depreciating the funds spent by the Soviet Union on their development and production.

In accordance with the July 1987 decision of the "competitive strategy" policy council, the primary direction for development of **general purpose forces** is considered to be the creation of precision weapon systems of various ranges integrated with advanced reconnaissance, command and control, and weapon control assets. In the opinion of American specialists, the possibility of creating basically corps-level autonomous integrated reconnaissance and strike systems was confirmed. Their strong points, including high potential capabilities for destroying enemy armored equipment, were identified during the tests. Among weak points are low survivability of integrated reconnaissance and strike systems on the modern battlefield, where disabling of any system elements paralyzes the entire system. In this connection the Pentagon plans to shift to a new level of developments with the objective of creating a unified automated system in a theater of operations that consolidates the ground forces' precision weapons, tactical and deck-based aircraft, and EW as well as reconnaissance, communications, intelligence processing and command and

control systems. The automated system must provide the capability of delivering a surprise coordinated strike with nonnuclear weapons against the most important targets to the full depth of operational-strategic alignment of Warsaw Pact forces.

Creation of the new F-117 fighter and ATA (A-12) attack aircraft, which are being developed with broad use of stealth technology, as well as creation of new effective airborne weapon systems will be a very important direction in the development of tactical and deck-based aircraft. According to the American leadership's concept, this will place the Soviet Union face to face with the need to modernize tactical air defense and qualitatively upgrade the aircraft inventory of front aviation.

It is planned to develop the Navy along two main directions. The first is an increase in the role of fleet surface forces by outfitting them with cruise missiles as well as upgrading their air defense system. The second is in ASW weapons with the objective of creating conditions for ensuring continuous tracking of Soviet nuclear-powered missile submarines and their reliable engagement in case war begins.

"COMPETITIVE" STRATEGY: A STRATEGIC PLANNING METHOD. The "competitive strategy" concept saw further development after the INF Treaty. The most reactionary U.S. circles perceived it as a "theoretical platform" for developing all kinds of compensatory measures aimed at emasculating the Treaty's substance and for planning military policy as a whole. The sphere of its application began to be extended from the military-technical sphere to foreign policy, economics and ideology.⁷ As F. Carlucci declared, "competitive" strategy essentially represents a **method of strategic planning** of U.S. national policy with consideration of a long-range confrontation with the Soviet Union.

Despite the fact that "competitive" strategy initially was developed for peacetime conditions, it has been used more and more often since the latter half of 1987 for planning **military operations**. The special working group on "competitive strategy" policy carefully studied possible warmaking options in Europe between NATO and the Warsaw Pact using only conventional weapons. Based on the fundamental principles of "competitive" strategy, it was recommended concentrating main efforts in the initial stage of military operations on accomplishing the following missions: destroying and engaging Warsaw Pact air forces at airfields and knocking out airfield navigation aids; disrupting the organized advance and commitment of second echelons and reserves; disrupting the Warsaw Pact joint armed forces command and control system at an operational-strategic level; and conducting operations on the flanks of the European theater of war and in other theaters with the objective of preventing reinforcement of the Soviet force grouping in Europe, imposing a protracted war on the USSR on several fronts and, taking advantage of the West's coalition superiority in economics and in human

and financial resources, forcing the USSR to accept the American side's surrender conditions.

To accomplish these missions it is recommended that U.S. Air Force and U.S. Army capabilities for destroying aircraft at airfields and airfield navigation aids be increased considerably by developing new effective reconnaissance and strike drones, airborne weapon systems, and long-range precision missiles.

The working group's recommendations were checked out on models of combat operations between NATO Allied Forces and Warsaw Pact Joint Armed Forces with consideration of the delivery of new weapon systems and of a table of organization structure of the mid-1990's.⁸ Simulation results were as follows: in 28 days of combat operations the Orange forces (Warsaw Pact) were able to advance only 30 km into the interior of FRG territory (under conditions of the game the Orange were the "aggressors") and were forced to accept Blue conditions for ceasing military operations because of considerable personnel and equipment losses as well as an absence of reserves.

It is characteristic that in the assessment of American military specialists, the following factors played a deciding role in the Blue victory: wide use of precision weapons; increased expenditure of conventional ammunition (by almost twofold in some phases of the operation) despite this; and use of the latest automated intelligence collection and processing, command and control and weapon control systems.

Application of "competitive" strategy principles to the **foreign policy** sphere presumes the use of diplomatic means for achieving U.S. military superiority. Emphasis here is placed on recommendations contained in National Security Council Directive NSC-68⁹ on advancing those demands in talks with the USSR which would appear fair in the eyes of the world public but in practice would ensure a weakening of the Soviet Union's position. It is characteristic that any display of readiness for compromises by the Soviet side is considered a sign of a weakness in its position, and this automatically should lead to further rigidification of American demands calculated for even more cardinal concessions.

According to statements of representatives from the closest entourage of G. Bush, as military confrontation with the USSR decreases **economic might** will have more and more significance as a deciding instrument of forceful pressure on the Soviet Union, and it is here that the primary provisions of "competitive" strategy can be fully used.

In the **ideological sphere** special emphasis is placed on the deliberate distortion of objectives and missions of Soviet foreign and domestic policy and on the exaggeration of existing difficulties, with maximum advantage taken of opportunities provided by the process of democratization and glasnost.

The place of "competitive" strategy in American military doctrine is determined by its objectives and by the missions to be accomplished. Having been developed for determining the most effective directions of U.S. military-technical policy within the framework of existing military strategy, it now has turned into a policy direction called upon to ensure attainment of objectives of a "national security" strategy which consolidates and coordinates foreign-policy, military, economic and other efforts for affirming the interests of American imperialism.

And so despite positive improvements in Soviet-American relations "competitive" strategy, according to the concept of the U.S. military-political leadership, is called upon to become a new universal means of optimizing varied efforts aimed against the Soviet Union. Having an openly adventurist, militarist character, it is designed for achieving and maintaining lengthy U.S. military and economic superiority through effective use of the latest achievements of science and technology and a shift of the arms race into a qualitatively new sphere. Despite the planned stability of military expenditures and a certain reduction in regular components of the Armed Forces, the present U.S. administration is actively using "competitive" strategy for determining basic directions of military organizational development for the 1990's.

Footnotes

1. The name of this strategy is found in a number of Soviet and foreign publications in the following versions: "strategies of competition," "competitive strategies," "competing strategies" and the "strategic concept of competition."
2. THE NEW REPUBLIC, 28 November 1988.
3. KRASNAYA ZVEZDA, 13 April 1989.
4. AVIATION WEEK AND SPACE TECHNOLOGY, 1 February 1988.
5. Ibid., 3 October 1988.
6. AEROSPACE DAILY, 22 November 1988.
7. Ibid., 3 November 1988.
8. ARMED FORCES JOURNAL, October, 1988.
9. AEROSPACE DAILY, 3 November 1988.

COPYRIGHT: "Zarubezhnoye voyennoye obozreniye", 1989.

Japan's Military-Political Command and Control Entities

904Q0001B Moscow ZARUBEZHNOYE
VOYENNOYE OBOZRENIYE in Russian
No 8, Aug 89 (signed to press 23 Aug 89) pp 8-13

[Article by Lt Col A. Rusanov, candidate of military sciences]

[Text] In recent years Japan has been devoting increased attention to numerous aspects of military policy. This is shown by the course toward building up the country's military potential consistently followed by ruling circles. The most prominent party leaders (Liberal-Democratic Party [LDP]) and leaders of state and other entities are taking part in its development. A leading role in determining primary points of military policy rests with the Cabinet of Ministers. The National Security Council [NSC], the National Security Integration Council and the Japanese Defense Agency [JDA], which are subordinate to the Cabinet of Ministers, are primarily engaged in studying, developing and implementing military policy.

The **National Security Council** was formed in July 1986 based on the National Defense Council, the prime minister's consultative body which existed since 1956. The NSC's makeup and functions have expanded somewhat compared with the National Defense Council. The secretary-general of the Cabinet of Ministers and chairman of the Public Safety Commission were added along with the prime minister (supreme commander of Armed Forces and chairman of the NSC), ministers of foreign affairs and finance, and chiefs of the JDA and Economic Planning Agency. Other ministers, the chairman of the Joint Chiefs of Staff [JCS] and appropriate specialists can be called in as consultants if necessary by the prime minister's decision.

The NSC handles matters of developing recommendations on basic directions of military policy, organizational development and employment of the Armed Forces, development of military production and so on.

Although the NSC officially is considered to be a consultative body for the prime minister, it essentially makes the final decision on the most important national security questions (when its sessions are chaired by the prime minister). The NSC devotes primary attention in its work to problems of organizational development and technical outfitting of the Japanese Self-Defense Forces [SDF].

In connection with the concept of "national security integration" adopted by Japan's military-political leadership in December 1980, a National Security Integration Council was formed as a consultative body under the Cabinet of Ministers. Its makeup includes the prime minister (chairman); ministers of foreign affairs, finance,

international trade and industry, transport, and agriculture and forestry; chiefs of the JDA, Science and Technology Agency, and Economic Planning Agency; secretary general of the Cabinet of Ministers; and secretary general of the LDP and other party leaders. Missions of the National Security Integration Council include preparing recommendations for the government on political, economic, S&T, military and other national security aspects as well as coordinating the work of ministries and departments in this sphere.

An analysis of the National Security Integration Council's work during the period 1980-1988 performed by Japanese experts shows that 17 of its sessions considered 55 questions on the following subjects: status of Japanese power engineering, including the supply of petroleum and use of nuclear and other forms of energy (these problems were discussed 12 times); foreign policy activity, including preparation for foreign visits by Japanese political and military leaders (11 times); development trends of the world economy and economic cooperation with other states (8 times); status and development of science, technology and international cooperation in this sphere (5 times); the food supply, including questions of conducting talks with the USSR on fishing problems (5 times); assurance of navigation safety in the Persian Gulf (4 times); creation of rare metals reserves (3 times); cooperation with foreign countries in the sphere of transportation development (2 times); basic directions of Armed Forces organizational development (once); defense of sea lines of communication in the 1,000 nm zone (once); financing measures in the sphere of national security integration (once); and prospects for the development of information science (once).

Thus the work of the National Security Integration Council is aimed at developing and coordinating national security measures basically by nonmilitary means, and there is a precise delineation of functions between the NSC and National Security Integration Council: the former's competence includes primarily military aspects of national security, and that of the latter includes diplomatic, economic, S&T and other aspects.

One other body handling national security problems was created under the Cabinet of Ministers in September 1987: the **Conference on the Export Control Coordination Committee (COCOM)**, the mission of which includes supervising the export of Japanese products to socialist countries. The makeup of the new body includes the secretary general of the Cabinet of Ministers; the ministers of justice, foreign affairs, finance, and international trade and industry; chief of the JDA; and chairman of the state Public Safety Committee. Three sessions were held during 1987-1988 which examined measures for further rigidifying (in accordance with demands of COCOM) restrictions on export of Japanese products and technology to socialist countries, and above all to the USSR.

Japanese experts believe that the parallel existence of three bodies engaged in different aspects of national security within the framework of the Cabinet of Ministers contributes to a search for the most rational ways and organizational forms for its development and realization.

The most important role in developing and conducting Japanese military policy belongs to the **Japanese Defense Agency**. It is also given responsibility for organizational development of the Armed Forces, their operational readiness, logistic support, organization of command and control of Army and Navy forces, direction of military R&D, and fulfillment of agreements with the United States on the stationing of American troops and installations on the country's territory.

The JDA is headed by a chief with minister of state rank appointed by the prime minister, usually from among the most prominent representatives of the ruling party; he has two deputies (permanent and parliamentary) as well as a group of advisers. All these leadership positions are filled by civilians. In addition, the JDA includes a Secretariat and departments (defense, armament, personnel, instruction and combat training, finance). Immediately subordinate to the JDA chief are the JCS, Armed Forces branch staffs, the Military Construction Agency, Procurements Agency, Technical Research Center, Defense Research Institute and other military establishments. The JDA is manned by highly qualified civilian specialists (over 500), of whom some 70 percent have been working here for from 15 to 30 years.

The Secretariat handles clerical procedures, information problems and legal problems.

The Defense Department, which is the primary JDA agency responsible for long-range planning of SDF organizational development and other matters, considers proposals and makes decisions on upgrading the Armed Forces organizational structure and on the composition and correlation of their branches and combat (naval) arms, and evaluates the status and development prospects of a future enemy's army. As a rule, planning documents developed by the JCS and by Armed Forces branch staffs are briefed to the JDA chief only after their approval by the Defense Department.

The Armaments Department considers proposals for satisfying troop requirements for weapons, military equipment and ammunition and draws up programs for technical outfitting of the SDF.

The Personnel Department is responsible for cadre support of Army and Navy forces, bringing large and small units up to established TO&E standards, and building up a trained military reserve.

The Instruction and Combat Training Department handles questions of planning and organizing personnel instruction in military educational institutions and of combat training and medical support for the Armed Forces.

The Finance Department advances proposals for financing the plans for SDF organizational development and coordinates the draft JDA budget with the Ministry of Finance.

The JCS is subordinate to the JDA chief and is considered a consultative body. It elaborates the general principles and basic directions of Army development; the plans for its organizational development, operational and combat training, and logistic support; and proposals for organizing coordination among Armed Forces branches; and it directs military intelligence. In case of war the JCS will function as the supreme entity of operational leadership.

The chairman of the JCS has the highest military rank in the SDF, that of general. He is appointed from among commanders or chiefs of staff of Armed Forces branches. The JCS additionally includes commanders of the Army, Air Force and Navy. The chairman can be invited to NSC sessions by order of the prime minister.

The Secretariat, which includes five sections, is the JCS working body. The first section assesses troop requirements for personnel and handles mobilization questions. The second is responsible for military intelligence. The third decides questions of employment of the Armed Forces and their branches, organization of command and control and communications, and organization of troop combat and operational training. The fourth draws up proposals for logistic support and the fifth is responsible for the status and development of weapons and military equipment.

The scope of missions assigned to the JCS has grown considerably in recent years and its status as an operational control entity has risen. This is shown in particular by the fact that from 1980 through 1988 the number of officers and generals almost doubled (from 83 to 160) while remaining almost at the previous level in the JDA and other Armed Forces command and control entities.

Staffs of Armed Forces branches are the supreme command and control entities of respective Armed Forces branches. Their commanders have the military rank of general. The structure of staffs has much in common and as a rule includes entities which handle questions of operational planning, intelligence, personnel, combat training and logistic support. Staffs prepare materials for higher echelons' decisions on branch composition and overall structure, outfitting of troops, distribution of personnel and assets in accordance with missions and operational tasking, and development of new kinds and models of weapons and military equipment.

The *Military Construction Agency* prepares documents for decisionmaking on construction, leasing, upkeep and maintenance of installations being used by Japanese and U.S. Armed Forces.

The *Procurements Agency* prepares decisions on placing orders with companies for production of weapons and military equipment and supervises progress of their fulfillment.

The *Technical Research Center* prepares scientific recommendations on directions of military equipment development; draws up operational-tactical requirements for weapons and for their unification and standardization; and evaluates the quality of models. It includes five research institutes and six test ranges.

The *Defense Research Institute* engages in the study of military, political, economic, social and other aspects of state activity, and in particular the development of theoretical foundations of military organizational development and SDF employment and the training of officers and highly placed civilian officials of the JDA as well as of other ministries and departments. The Institute's recommendations are taken into consideration in elaborating Japan's military doctrine.

The Liberal Democratic Party plays an important role in shaping Japanese military policy. Having the majority in the Diet, it has been the ruling party for over 30 years now. The LDP chairman, who simultaneously holds the post of prime minister, exercises overall direction over the LDP's military activity. He involves the secretary general and other prominent party figures in elaborating military policy.

Special entities on the LDP political council which were established in the 1950's—national defense section, security affairs committee, and special commission on military bases—handle problems of military policy and develop specific recommendations in this area. Three subcommissions were formed within the framework of the security affairs committee in the late 1970's and early 1980's in connection with an expanded scope and increased complexity of military organizational development tasks: subcommissions for Armed Forces organizational development, for improving military legislation, and for civil defense.

Over 150 deputies of the Diet from the ruling party, including former JDA chiefs, some retired generals and other persons, take part in the work of LDP entities handling military problems. Contacts between the party leadership and military departments take place through them. These persons comprise the backbone of the party's so-called "defense lobby," which together with members of the influential "Association of LDP Diet Deputies for Strengthening National Defense" numbers up to 200 persons, i.e., around half of the ruling party's entire representation in the Diet. The "defense lobby" actively works to build up Armed Forces combat might and to expand and strengthen Japan's military-political alliance with the United States. Recommendations of these entities are considered by the party's political council, then are approved by its executive council and

sent to the Cabinet of Ministers, which after NSC adjustment puts them out as a bill for discussion of a Diet session.

Routine sessions of the Diet, which approves military expenditures, are convened once a year. Day-to-day activity of both of its houses takes place within the framework of permanent and special commissions. Special security affairs commissions in which the LDP has the majority of votes were formed in the early 1980's to consider military-political questions in both houses of the Diet.

Entities of monopolistic associations connected with military production have a noticeable influence on shaping Japanese military policy. They have an opportunity to defend their interests through participation of representatives of the largest monopolies in the work of various study organizations and consultative entities of government and through financial support to the LDP.

A complicated and ramified system of monopoly entities has been created in Japan to coordinate overall strategy and exert constant influence on the state administrative apparatus. The Japan Federation of Economic Organizations, which includes some 800 corporations and banks, exercises overall direction over their activities. Japanese economists call it the "general staff of financial-monopoly capital," and call the director of the Federation the "prime minister of the business world." Being essentially the principal coordinating center of Japanese monopolies, the Federation handles the most common questions of national economic development including organization of military production.

The Defense Production Committee established in 1952 and uniting some 80 of the largest arms producing companies is a special Federation entity responsible for planning military production and distributing military orders. The chairman of the Defense Production Committee as a rule is a representative of Mitsubishi Jukogyo, the largest and most influential company in Japanese military-industrial circles which accounts for from 20 to 25 percent of JDA orders. Six subcommittees function in the Defense Production Committee apparatus: pricing problems, R&D, arms production, planning, foreign market conditions study, and liaison. The Defense Production Committee directs the activity of its sectorial associations, which unite industrialists of one sector.

Japan presently has over 20 sectorial associations directly or indirectly connected with military production. The following associations are the most active in this sphere: arms manufacturers, aerospace, shipbuilding, electronics industry, and rocket construction. The first association plays the leading role. It was established in 1951 and consolidates some 120 major companies. It has 11 committees: working relations, electronic equipment, artillery and small arms, artillery and small

arms ammunition, powders and explosives, motor transport equipment, ship armament, guided weapons, and submarine weapons (three committees).

In coordinating the activity of monopolies in the military production sphere, the Defense Production Committee and sectorial associations maintain constant contact with the JDA, with the Ministry of International Trade and Industry, and with special LDP entities. Specialized associations are used for arranging working contacts with JDA departments and their subunits such as for Armed Forces supply (established in 1977) and for defense equipment (established in 1980). The former is intended for drawing up recommendations in the sphere of organization of military deliveries and cooperates with the Procurements Agency. The latter prepares recommendations on organization of military R&D and coordinates with the Technical Research Center.

Private military science centers whose activity is financed primarily by major monopolies have been participating more and more actively in developing the principal directions of Japan's military policy since the late 1970's. The most influential of them is the Institute of Peace and Security Problems established in 1978 (along the lines of the London Strategic Studies Institute) and headed by Professor M. Inoki, a very prominent Japanese political scientist. The Institute publishes the "Security in Asia" yearbook in Japanese and English and accounts on scientific research on the topic "Peace and Security," draws up reports on current military problems (in accordance with JDA assignments), and participates in studies conducted jointly with foreign military science centers.

The Japanese Strategic Studies Center established in 1980 also plays an appreciable role in elaborating military problems. Its director is S. Kanemaru, a prominent LDP figure and former JDA chief. The Center puts out an information bulletin and prepares recommendations on questions of Armed Forces organizational development and combat employment.

Joint Japanese-American entities, called upon to ensure coordination of the two countries' military efforts within the framework of the "Treaty on Mutual Cooperation and Security" (1960), hold a special place in the system of Japanese military-political entities.

The most important military-political decisions in the sphere of Japanese-American military cooperation are made at periodic meetings of the Japanese prime minister and U.S. president. Regular meetings of the JDA chief and U.S. Secretary of Defense have been held since 1975 (usually twice a year) for preparing and further concretizing decisions made at the highest level.

The Security Consultative Committee established in 1960 plays the chief role in the system of Japanese-American coordinating entities. Its tasks include considering the most important questions of bilateral military-political cooperation and developing recommendations in this sphere. The committee makeup includes the JDA

chief and minister of foreign affairs from the Japanese side, and the commander in chief of the U.S. Pacific Command and the U.S. Ambassador to Japan from the American side. Committee sessions usually are held annually.

Two subcommittees function within the framework of the Security Consultative Committee for maintaining constant working contacts between representatives of Japan and the United States: a security subcommittee and a military organizational development subcommittee. The former, intended for exchanging opinions and preparing corresponding recommendations, has no permanent makeup. It can include representatives of different interested ministries and departments depending on questions being discussed. Consultative conferences usually are held in the Hawaiian Islands once a year at the deputy minister level.

The military organizational development subcommittee was established in 1976. Its makeup includes the chief of the JDA Defense Department, chief of the JCS Secretariat, and chief of the Ministry of Foreign Affairs North American Department from the Japanese side; and the chief of staff of U.S. Armed Forces in Japan and the U.S. adviser-envoy to Japan from the American side. The subcommittee's task is to conduct studies to develop plans for joint operational employment of Japanese and U.S. armed forces with the appearance of an emergency situation in the Far East. Three special groups have been established within the subcommittee framework for resolving specific questions of military organizational development: operational coordination, intelligence exchange, and logistic support. Nine subcommittee sessions were held in the period from 1976 through 1988.

A security consultative group established in 1973 resolves current questions involving fulfillment of conditions of the Japanese-American "security treaty" and coordination of the parties' activity in this sphere. It includes the chief of the JDA Defense Department, chairman of the JCS, chief of the Military Construction Agency, an adviser to the minister of foreign affairs and chief of the Ministry of Foreign Affairs North American Department from Japan; and the commander in chief and chief of staff of U.S. Armed Forces in Japan and the U.S. adviser-envoy to Japan from the U.S. side. There were 24 sessions of the group held from 1973 through 1988.

Questions concerning the status of American forces in Japan, including their use of installations on the country's territory, are examined by a joint administrative matters committee. It includes the chief of the Military Construction Directorate and chief of the Ministry of Foreign Affairs North American Department from the Japanese side; and the chief of staff of U.S. Armed Forces in Japan and the U.S. adviser in Japan from the American side. Committee sessions usually are held once every two weeks.

A Japanese-American consultative conference on military equipment and technology has been held since 1980 to decide questions involving military-technical cooperation of the two countries. The Japanese side is represented in this entity by the chief of the JDA Armament Department, and the American side is represented by the deputy under secretary of defense for international programs and technology. The conference basically handles questions of organizing an exchange of military-technical information, Japan's procurement of American weapons and military equipment, as well as procurement of licenses for their production. The conference works in Washington and Tokyo in turn. Ten sessions have been held from 1980 through 1987.

A joint Japanese-American Military Technology Commission was established in November 1984 in connection with Japan's fundamental decision made in November 1983 on making available Japanese military technology to the United States as well as with the need for further detailed study of this question. Its task includes holding periodic consultations and preparing appropriate intergovernmental agreements for each specific instance of a military technology transfer.

Japanese experts believe that the country's existing system of military-political entities on the whole permits its ruling circles to effectively direct measures for building up Japan's military might and strengthening and expanding military cooperation with the United States.

COPYRIGHT: "Zarubezhnoye voyennoye obozreniye", 1989.

U.S., South Korean Armed Forces Exercise Team Spirit-89

*904Q0001C Moscow ZARUBEZHNOYE
VOYENNOYE OBOZRENIYE in Russian
No 8, Aug 89 (signed to press 23 Aug 89) pp 14-16*

[Article by Col B. Maksimov]

[Text] The U.S.-South Korean command conducted the largest joint exercise of U.S. and South Korean armed forces, codenamed Team Spirit-89, for the 14th time during February-April 1989 on the territory of South Korea and in contiguous waters of the Sea of Japan and Yellow Sea.

Preparation for the exercise began essentially from the moment the previous exercise of this type ended in the spring of 1988. During numerous conferences, assemblies and drills planning was accomplished and questions were coordinated and updated on logistic support and on organizing movements of aviation, personnel and cargoes from the continental United States and U.S. bases in the Pacific to the Korean Peninsula. In addition, individual elements of Exercise Team Spirit-89 were worked out while conducting other U.S. Armed Forces exercises jointly with armed forces of allies in the region.

One variant of an aggravated international situation on the Korean Peninsula with the subsequent outbreak of an armed conflict between South Korea and North Korea was made the basis of the operational-strategic concept. The exercise scenario envisaged offensive and defensive operations by ground forces and an amphibious landing operation. Despite the fact that operations of ground forces and Marines were planned at a considerable distance from each other and on different axes, their objectives and missions were united by a common concept.

The principal military-political objectives of the exercise were to check and rehearse plans for reinforcing the U.S. force grouping in South Korea by the movement and operational deployment of large and small units from the continental United States, Alaska, Japan, the Philippines and Guam and their conduct of joint combat operations; and to show the force and readiness of the United States to give military assistance to allies in the region in a crisis situation.

A total of 209,000 persons took part in the exercise, including 140,000 South Korean servicemen and 69,000 Americans (39,000 from troop reinforcements and 30,000 from those stationed on the Korean Peninsula).

The air grouping numbered over 800 U.S. and South Korean Air Force aircraft, including B-52 strategic bombers, U-2 and SR-71 strategic reconnaissance aircraft, and E-3 AWACS early warning and control aircraft. Tactical aviation was represented in the exercise by tactical fighters and by attack, reconnaissance and transport aircraft from PACAF's 5th, 7th and 13th air forces as well as by aircraft of the USAF Tactical Air Command (33d Tactical Fighter Wing, Eglin AFB, Florida) and the Oregon, Nevada and California Air National Guard.

Several dozen ships of basic types from the U.S. Navy were in action in the exercise including the carrier "Midway," surface combatants and nuclear submarines outfitted with Tomahawk cruise missiles, as well as Marine and deck-based aircraft.

During the preparatory phase (1 February-13 March) measures were rehearsed for converting the 600,000-strong South Korean Army and 43,000-strong U.S. force grouping on the territory of South Korea from a peacetime to a wartime footing; there was a movement of Army, Air Force and Navy units and subunits to the Korean Peninsula; and a check was made of the teamwork of large and small units staffs while rehearsing the conduct of combat operations.

U.S. troop reinforcements were moved by sea and air. More than 12,000 servicemen were rebased just from the U.S. I Corps (Fort Lewis, Washington). Half of them were regular troops and the other half consisted of Reserve and National Guard personnel assigned to the corps under mobilization deployment plans. In addition, units and subunits from other large units were delivered to the Korean Peninsula, including from the 7th Light Infantry Division (Fort Ord, California), 25th Light

Infantry Division (Fort Shafter, Hawaii), and 147th Field Artillery Brigade of the South Dakota National Guard. There were simultaneous large-scale strategic movements of logistic support assets, military cargoes and equipment. C-5 and C-141 aircraft of the USAF Military Airlift Command and Boeing 747, DC-8, DC-10 and L-1011 aircraft of civilian airlines which are part of the MAC reserve were used for delivering personnel and cargoes.

U.S. Marine forces and assets were delivered to the Korean Peninsula by air and sea. Heavy weapons and military equipment were carried by Military Sealift Command transports and vessels.

In the main exercise phase (14-23 March) ground forces in coordination with strategic and tactical aviation practiced various methods of joint offensive and defensive combat operations and perfected techniques and methods of employing new systems of military equipment and weapons, including mass destruction weapons.

The U.S.-South Korean force grouping was conditionally divided into the Blue and Orange. Operations by ground forces unfolded on mountainous terrain east of Seoul (50 km south of the Demilitarized Zone). According to the exercise plan, operations in this area were conducted in east and west directions.

The Blue forces, which included units and subunits of U.S. and South Korean Marines, conducted a separate amphibious landing operation near the port of Pohang on the east coast of the Korean Peninsula, during which they practiced a Marine landing in unprepared coastal sectors using assault landing craft and assault transport helicopters, and practiced combat operations to hold and expand a captured beachhead in coordination with ships and aircraft of the U.S. Seventh Fleet and the South Korean Navy.

Individual exercises and drills were conducted during this phase to practice methods of negotiating water obstacles, to organize personnel and cargo movements, and to drop or land them on landing zones of limited size.

Five C-141 aircraft made a nonstop airlift of subunits of the U.S. Army 1st Special Forces Group (Fort Lewis, Washington) to the exercise area.

During the exercise much attention was given to practicing tactical air operations in the interests of ground forces. Pilots accomplished missions involving winning air superiority, close air support, interdiction, aerial reconnaissance, and search and rescue of crews.

Each day tactical aviation flew over 700 sorties, of which over 300 were flown by the U.S. Air Force and 400 by the South Korean Air Force. Up to 20 percent of sorties in the first 24 hours of this exercise phase were flown to repel an air attack. Aircraft combat readiness was maintained at a 95 percent level.

Under conditions of a high degree of probability that main airfields were knocked out, tactical aviation flight personnel and ground services rehearsed actions in organizing flights from specially prepared sectors of freeways (there are over ten of them on the territory of South Korea) and temporary airstrips having artificial-surface runways.

As a rule, freeway sectors are up to 45 m wide and up to 2,400 m long and can be used by essentially all types of U.S. and South Korean Air Force tactical aircraft. Marine aviation and U.S. Navy deck-based aviation practiced landing on such "alternate airfields." Temporary airstrips usually are constructed for C-130 aircraft. Such an airfield was built near Yaju (in the Han River valley) out of 28,000 aluminum plates. Its runway was 19 m wide and 1,050 m long.

Command and control over tactical air operations was exercised by forces and assets of the 5th Tactical Air Control Group using OA-10 aircraft. At least one E-3 early warning and control aircraft was in the air space of the southern part of the Korean Peninsula around the clock. EC-130 airborne command posts made up to two flights each day.

Exercise participants were moved to permanent stations in the final phase of the exercise.

Twenty-three servicemen died and 16 were wounded during the exercise.

The scope and character of Exercise Team Spirit-89 indicate that the U.S. and South Korean military leadership continue to be unwilling to notice positive processes occurring throughout the world aimed above all at alleviating its militarization. The lack of desire to follow a course toward normalizing the situation in the Far East and refusal to reduce arms and establish good-neighbor relations among countries of the region can lead to the formation of a source of dangerous regional and world contradictions on the Korean Peninsula.

COPYRIGHT: "Zarubezhnoye voyennoye obozreniye", 1989.

GROUND FORCES

U.S. Army Separate Armored Cavalry Regiment

*904Q0001D Moscow ZARUBEZHNOYE
VOYENNOYE OBOZRENIYE in Russian
No 8, Aug 89 (signed to press 23 Aug 89) pp 17-23*

[Article by Lt Col A. Volodin]

[Text] While recognizing the fact of nuclear arms parity between the United States and Soviet Union, at the same time the U.S. military-political leadership is not giving up attempts to disrupt it in its favor by a qualitative reoutfitting of its nuclear triad. It also devotes great attention to upgrading the general-purpose forces. In the

Fig. 1. Organization of U.S. Army separate armored cavalry regiment

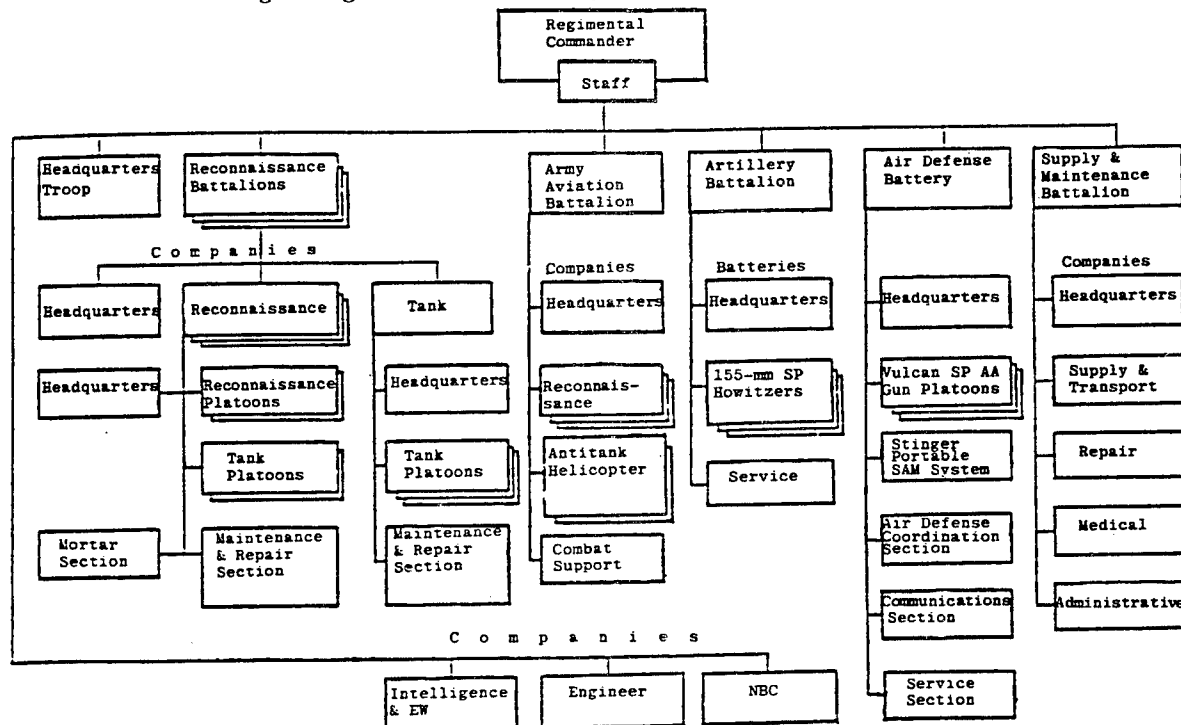

American command's assessment, the general-purpose forces can become a "weapon for breaking through" the existing balance between East and West thanks to modern western technology in creating advanced kinds of weapons and automated reconnaissance and command and control systems.

This striving shows up especially vividly during implementation of the Army-90 long-range program for Army organizational development (1981-1990). Intensive studies and practical measures for developing and making operational qualitatively new systems of weapons and combat equipment, for seeking optimum methods of their combat employment, and for upgrading the organizational structure are being carried out within its framework. Western specialists estimate that the outfitting of large and small Army units with modern weapons and military equipment (M1 and M1A1 Abrams tanks, M2 Bradley infantry fighting vehicles [IFV's], M3 combat reconnaissance vehicles [CRV's], the multiple launch rocket system [MLRS], and AH-64A Apache antitank helicopters), their conversion to the new Division-86 table of organization structure, and troops' mastery of methods of conducting combat operations in accordance with the "Air-Land Operation (Battle)" concept will assure the American command of increased combat capabilities of ground forces by at least 70 percent.

The foreign military press reports that the U.S. Army has seven separate armored cavalry regiments: three in the Regular Army and four in the National Guard. According to the above program, these regiments also are being converted to the new table of organization structure and

are being outfitted with modern weapons and military equipment. As of the beginning of 1988 all Regular Army regiments already had been converted to the new T/O&E. It is planned to complete conversion and reoutfitting of National Guard regiments by the end of 1990.

Organizationally the separate armored cavalry regiment is part of an army corps and is intended for accomplishing the following primary missions: reconnaissance, cover and security for combined arms large units and large strategic formations in the engagement and operation, operations as a combined-arms reserve, security and defense of the army corps rear, and independent combat operations on a secondary axis.

Composition and combat capabilities. Organizationally the separate armored cavalry regiment includes a headquarters and headquarters troop, three reconnaissance battalions, an army aviation battalion, a battalion of 155-mm self-propelled [SP] howitzers, an air defense battery, three separate companies (intelligence and EW, engineer, and NBC), and a supply and maintenance battalion (Fig. 1).

The *headquarters and headquarters troop* are for organization and command and control of operations by organic and attached subunits as well as for air defense of regimental command and control facilities. They have two platoons (communications and Stinger portable SAM system) and ten sections (headquarters, personnel, intelligence, operations, fire support, chemical, logistics, troop headquarters, rations and supply, and repair).

They have a total of 199 persons, 24 Stinger portable SAM systems, four M577A1 command and staff vehicles, one M113A1 APC, 88 radios and over 60 vehicles. Tactical, main and alternate command posts can be deployed on the basis of the headquarters and headquarters troop.

The *reconnaissance battalion* is the regiment's primary combat subunit and is intended for performing reconnaissance missions, providing combat outposts and security at the halt for large and small units of the army corps, and conducting offensive and defensive operations with limited objectives on secondary axes. It consists of a headquarters and headquarters troop, three reconnaissance troops and a tank company.

The headquarters and headquarters troop includes four platoons (communications, support, medical, and maintenance and repair) and nine sections (personnel, intelligence, operations, fire support, ground surveillance radar, armored vehicle launched bridge, logistic support, troop headquarters, and mess). The reconnaissance battalion headquarters and headquarters troop have a total of 207 persons. Forces and assets of these subunits can provide command and control over operations of organic and attached subunits and organize their logistic and medical support when the battalion conducts combat operations both as part of the regiment and independently.

The reconnaissance troop consists of a headquarters (M1 Abrams tank and M577A1 command and staff vehicle), two scout platoons (six M3 CRV's each), two tank platoons (four tanks each) and two sections: a mortar section (two M113A1 APC's with 81-mm mortars), and a maintenance and repair section. The troop has a total of 128 persons, 9 M1 Abrams tanks, 12 M3 CRV's, 2 mortars on M113A1 APC's and 1 M577A1 command and staff vehicle.

When the army corps is conducting offensive operations without a halt the reconnaissance troop can assign up to four scout teams (each one usually includes two tanks and two CRV's) and reconnoiter 2-4 routes in a designated zone or on an axis. When conducting reconnaissance in depth or in anticipation of a meeting engagement, the troop can be reinforced by air defense, engineer and chemical subunits to make up a reconnaissance detachment which reconnoiters along one route. The troop's zone of reconnaissance usually coincides with the brigade's zone of advance (10-15 km).

Observation posts and reconnaissance patrols are assigned from the troop for reconnaissance in the defense. Their number and makeup depend on the nature of enemy operations, the terrain, and alignment of the defending forces' combat formation.

When operating in a security area the reconnaissance troop can defend an assigned position located up to 60 km from the army corps main body.

When performing guard operations the troop usually is attached to a brigade and can assign up to three advance guards, flank guards, or rear guards. They are 3-4 km from the main body, which in the specialists' assessment should ensure their artillery support when engaging enemy subunits and the organized commitment of friendly units and subunits.

The tank company consists of a headquarters (two M1 Abrams tanks), three tank platoons (four tanks each), and a maintenance and repair section. It has a total of 74 persons and 14 M1 Abrams tanks. The company is capable of mobile offensive and defensive combat operations under conditions of limited visibility, heavy fire pressure and the enemy's use of mass destruction weapons. The company usually makes up the battalion commander's reserve when the reconnaissance battalion is accomplishing combat support missions (reconnaissance, security and cover).

The regiment's reconnaissance battalion has a total of 665 persons, 41 M1 Abrams tanks, 38 M3 CRV's, 6 81-mm mortars on M113A1 APC's, 9 M577A1 command and staff vehicles, 11 M113A1 APC's, over 150 radios and some 80 vehicles.

The *army aviation battalion* consists of a headquarters and headquarters company (278 persons, 1 general-purpose helicopter and 3 EW helicopters), three reconnaissance companies (34 persons, 6 reconnaissance helicopters and 4 antitank helicopters each), two antitank helicopter companies (38 persons, 4 reconnaissance helicopters and 7 antitank helicopters each) and a combat support company (50 persons, 15 general-purpose helicopters and 6 reconnaissance helicopters). The battalion has a total of 506 persons as well as 77 helicopters (26 antitank, 32 reconnaissance, 16 general-purpose and 3 EW), over 300 radios and 105 vehicles. To perform missions of aerial reconnaissance, fire support, and engagement of mobile enemy armored targets, the battalion can create 2-3 antitank helicopter attack groups (up to five antitank helicopters and three reconnaissance helicopters in each) and six heavy reconnaissance helicopter attack groups (up to three reconnaissance and two antitank helicopters in each), or nine light groups (two reconnaissance helicopters and one antitank helicopter each). The battalion can support reconnaissance by regimental subunits to a depth of 150 km.

The *artillery battalion* is made up of a headquarters and headquarters battery, three 155-mm SP howitzer batteries (each with eight guns and eight Dragon ATGM launchers), and a service battery. The battalion has a total of 717 persons, 24 155-mm SP howitzers, 24 Dragon ATGM launchers, 13 M577A1 command and staff vehicles, 15 M113A1 APC's, 80 radios and around 100 vehicles. A battalion volley can destroy personnel in the open on an area of up to 5 hectares. The artillery battalion usually is attached to reconnaissance battalions by battery when the regiment performs combat support

missions. The battalion is used centrally when the regiment conducts offensive or defensive operations on secondary axes.

The *air defense battery* includes a headquarters, three Vulcan SP AA gun platoons, a Stinger portable SAM system platoon and three sections (communications, air defense coordination, and service). It has a total of 184 persons, 12 Vulcan¹ SP AA guns, 28 Stinger portable SAM systems, 1 M577A1 command and staff vehicle, 4 M113A1 APC's, around 100 radios and over 50 vehicles. The regiment's air defense battery can simultaneously engage over 30 airborne targets flying at a speed up to 350 m/sec at altitudes of 30 m-3.5 km with a kill probability of 0.3-0.5. The air defense battery is used in a decentralized manner during combat operations: Vulcan SP AA gun platoons reinforced by a Stinger portable SAM system cover the reconnaissance battalion while the other Stinger portable SAM system teams cover the intelligence and EW company and regimental logistic support subunits and entities.

The *supply and maintenance battalion* includes a headquarters and headquarters company, supply company, transport company, repair company, medical company and administrative company. The battalion has a total of 1,015 persons, three M113H1 APC's, over 80 radios and around 250 vehicles. In a combat situation reconnaissance battalion service and maintenance groups are formed from the battalion, and some of the forces and assets remain subordinate to the separate armored cavalry regiment commander.

The *intelligence and EW company* consists of a headquarters, intelligence collection and analysis center and five platoons (three ELINT and ECM platoons, a communications platoon and a service platoon). The ELINT and ECM platoon has a headquarters and three squads: ELINT and DF squad, ECM squad, and Morse intercept squad. The company has 208 persons, 6 M577A1 command and staff vehicles, 3 M113A1 APC's, a Quick Fix-2 helicopter EW system, 2 Malthews helicopter EW systems, 2 AN/MLQ-34 TACJAM ground HF/VHF jammers, an AN/TLQ-17A ground HF/VHF jamming system, and over 50 vehicles.

The *engineer company* consists of a headquarters and five platoons (three engineer platoons, a clearance and obstacles platoon, and support platoon). The engineer company has a total of 188 persons, 6 Dragon ATGM launchers, an M577A1 command and staff vehicle, 12 M113A1 APC's, 3 armored vehicle launched bridges, 3 sets of mineclearing linear charges, 6 sets of SP ferries, 2 mine dispensers, over 30 radios and 30 vehicles.

The *NBC company* includes a headquarters, chemical section and three platoons: radiation and chemical reconnaissance platoon, decontamination platoon and support platoon. It has a total of 80 persons, 9 M113A1 APC's, 3 decontamination equipment sets, 3 radiation

reconnaissance instruments, 17 radios and over 20 vehicles. The company can detail up to nine chemical reconnaissance patrols and perform decontamination of 80 persons or four pieces of military equipment in one hour.

The separate armored cavalry regiment has 5,092 persons, 123 M1 Abrams tanks, 114 M3 CRV's, 80 M113A1 APC's, 24 155-mm SP howitzers, 18 81-mm mortars on M113A1 APC's, 30 Dragon ATGM launchers, 12 Vulcan SP AA guns, 52 Stinger portable SAM systems, 77 helicopters (32 reconnaissance, 26 antitank, 16 multipurpose and 3 EW), over 1,150 radios, some 560 night vision devices and over 900 motor vehicles.

The depth of reconnaissance reaches 70-80 km by the regiment's ground equipment and 150 km by its airborne equipment. American specialists estimate that the regiment is capable of reconnoitering up to 80 targets in a 24-hour period. While performing guard operations the separate armored cavalry regiment can conduct an area defense in the army corps security area on main axes of enemy advance. The possible distance of the regiment's positions from the FEBA is 15-75 km. In the defense the separate armored cavalry regiment can occupy an area 15-20 km wide and 20 km deep, and on the offensive it can operate in a zone 10-15 km wide.

Separate armored cavalry regiment on the offensive. Being the basic means of army corps tactical reconnaissance, the regiment usually performs reconnaissance missions along axes or in a designated zone with the objective of collecting information on the enemy and on the nature of terrain to the full depth of combat missions being accomplished by the army corps. The regiment's reconnaissance zone usually coincides with the army corps zone of advance and is up to 80 km wide. The regiment performs assigned missions in force; by observation; by operations of reconnaissance detachments, teams and patrols (ground and airborne); by a probing reconnaissance patrol; and by communications intercept.

When the army corps engages in offensive operations without a halt and in the absence of immediate contact with the enemy, the regiment is assigned missions of coming into contact with the enemy main body, determining its force composition, establishing the trace of the FEBA and alignment of the combat formation, identifying weak places in the enemy defense, and determining the fire plan. During combat operations by the corps main body for the first defense zone, regimental subunits conduct reconnaissance on the flanks or take advantage of intervals between advancing large and small units to move into the depth of the enemy defense. The basic objective is to identify the composition, lines and axes of operations of counterattacking enemy force groupings. When the army corps main body is exploiting success in the operational depth, separate armored cavalry regiment subunits reconnoiter areas in which, in the corps commander's assessment, enemy actions can delay further advance.

When the army corps is preparing an offensive from a position of immediate contact with the enemy, the separate armored cavalry regiment may receive a mission of conducting reconnaissance in force. This is done only by direction of the army corps commander and is organized and carried out under corps staff supervision. A reconnaissance in force is conducted by regimental subunits (from troop to battalion) simultaneously on several axes of the army corps area of responsibility.

While it is part of corps covering forces and when the corps is exploiting operational success, the separate armored cavalry regiment usually aligns its combat formation in a single echelon with the assignment of a reserve. The alignment of the regimental combat formation must provide cover for the main axes of advance of forward units and subunits, figuring one or two reconnaissance platoons per route.

American military specialists estimate that based on its organization and armament the separate armored cavalry regiment can successfully conduct independent offensive operations on secondary axes, on flanks of the army corps, or on axes where the enemy defense has been weakly prepared. The regimental combat formation depends above all on the nature of the enemy defense and can be aligned in one or two echelons. The artillery battalion and army aviation battalion usually are employed centrally. Missions are assigned to subunits by objectives. The regiment usually is assigned one or more objectives, and battalions also can be given intermediate objectives for convenience of command and control and for ensuring coordinated operations in an engagement (Fig. 2).

The separate armored cavalry regiment in the defense is employed for reconnaissance, for guard operations and for covering the corps main body, and it also can be

Fig. 2. Separate armored cavalry regiment in an army corps offensive (variant)

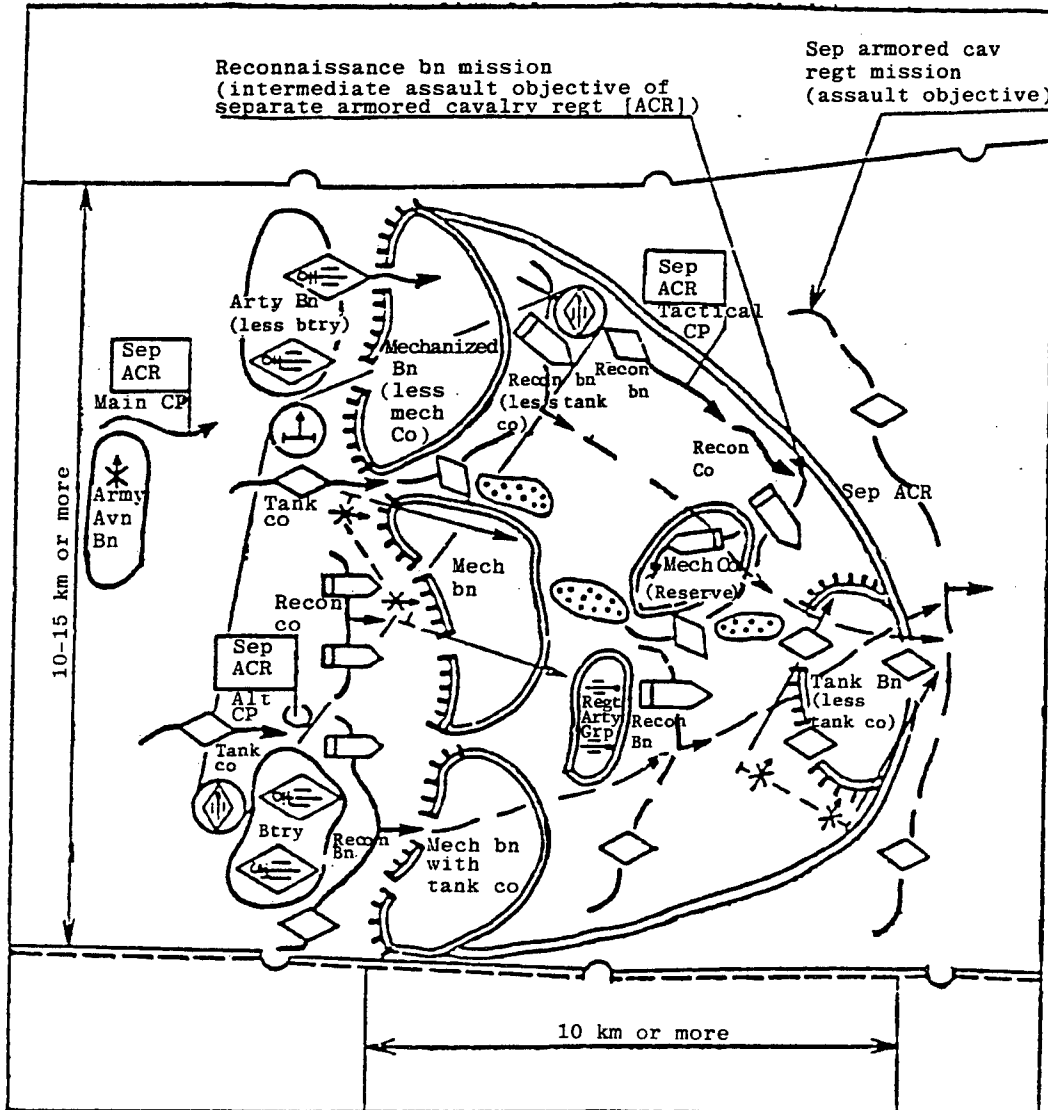

facilities, and provide a flexible intelligence gathering system. Tactical, main and alternate command posts are set up for command and control of organic and attached subunits in combat.

The tactical CP is accommodated in two M577A1 command and staff vehicles and includes officers of the staff intelligence section and operations section, intelligence officer, a tactical air liaison officer, a fire support team officer and the necessary number of communicators and drivers. The main CP displaces or is disposed in combat behind combat formations of the regiment's first echelon battalions.

The main CP consists of two parts: combat operations control center [COCC] and a support group. The COCC includes officers of the intelligence and operations sections, fire support team officer, tactical air control team, army corps staff liaison officer and liaison officer with staffs of allied and adjacent large and small units. The main CP is accommodated in three M577A1 command and staff vehicles, one M113 APC and several special vehicles and is deployed in the corps main defense area.

The alternate CP is accommodated in three command and staff vehicles and two or three special vehicles. It includes officers of the staff operations section, personnel section, supply section and communications platoon.

In addition, a headquarters group is formed headed by the regimental commander; it includes the chief of staff, operations section chief, tactical air liaison officer, chief of the fire support team, and chief of the engineer service. The group is accommodated in one M577A1 command and staff vehicle and in combat it is part of the tactical CP (more often) or the COCC at the main CP depending on the situation. The communications system of the separate armored cavalry regiment includes three main radio nets: regimental commander (headquarters), intelligence, and administrative and logistics.

In the assessment of American military specialists, the separate armored cavalry regiment is the most versatile combat unit capable of accomplishing reconnaissance and guard operations and of conducting independent offensive and defensive operations on secondary axes.

Fig. 4. Separate armored cavalry regiment mobile defense

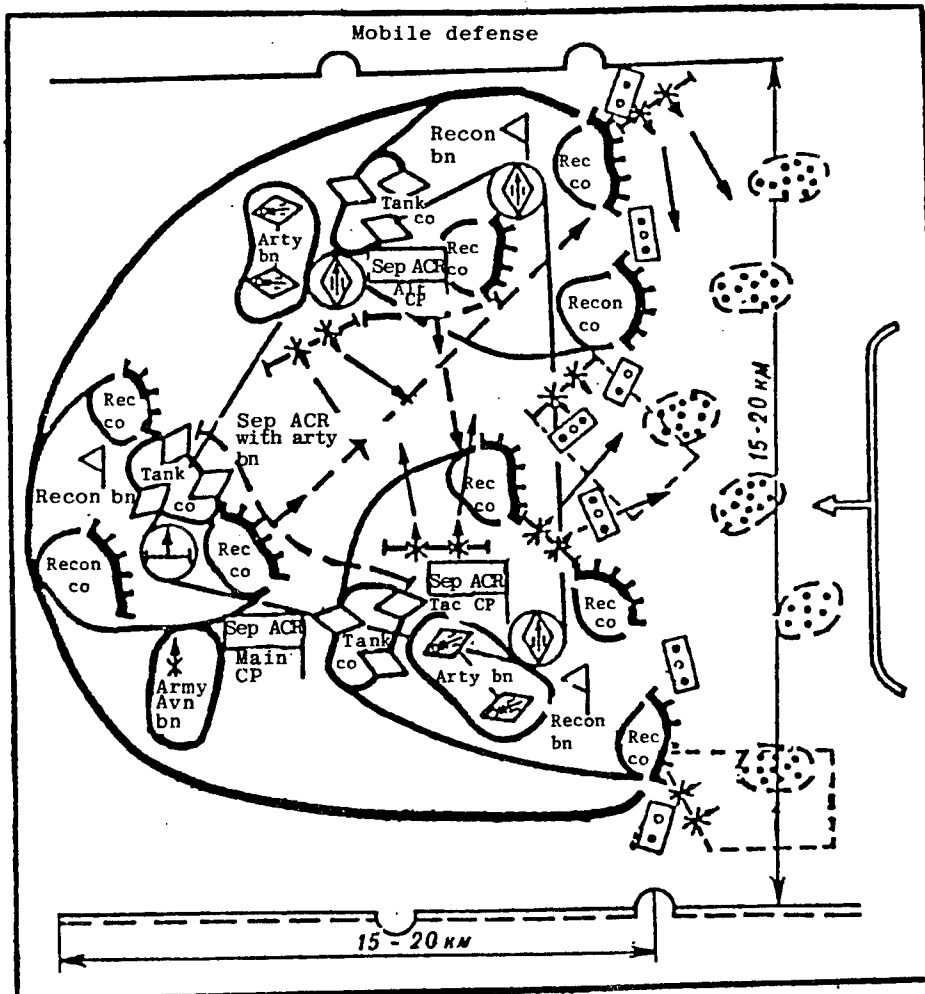
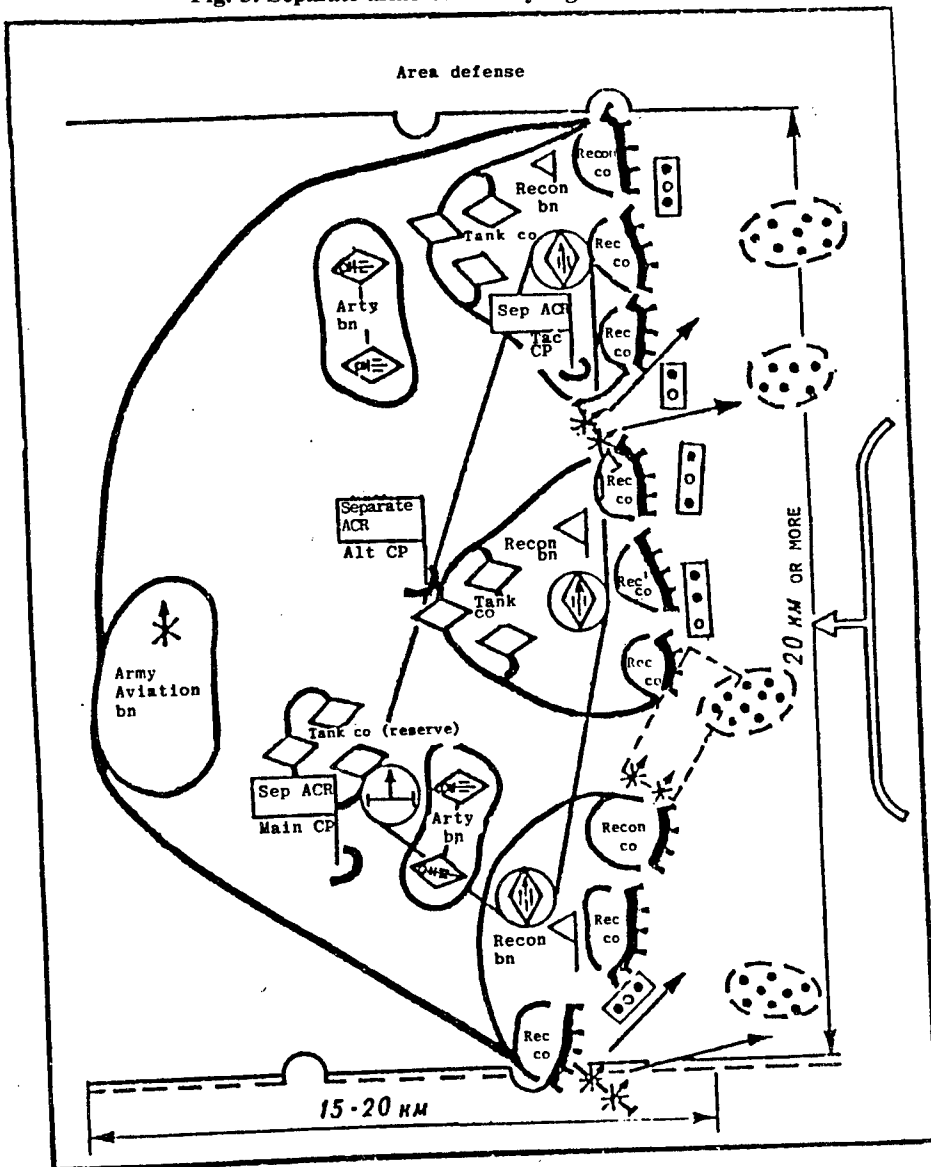

Fig. 5. Separate armored cavalry regiment area defense



Footnotes

1. The ADATS general-purpose air defense antitank missile system has been coming into service with Army large and small units since 1989—Ed.

COPYRIGHT: "Zarubezhnoye voyennoye obozreniye", 1989.

Program for Upgrading the U.S. AH-64A Apache Combat Helicopter

904Q0001E Moscow ZARUBEZHNOYE
VOYENNOYE OBOZRENIYE in Russian No 8,
Aug 89 (signed to press 23 Aug 89) pp 24-26

[Article by Col V. Nelin]

[Text] Attaching great significance to the development of Army Aviation, an arm of the ground forces, the U.S. Department of the Army leadership places great emphasis on building up its combat capabilities by constantly upgrading and improving organic weapons and combat equipment. For example, the AH-64A Apache combat helicopter (Fig. 1 [figure not reproduced]), which according to the foreign press is the most advanced among helicopters of NATO armies, began to come into service with the U.S. Army in 1984. Just a year later, however, the developing firm of McDonnell Douglas received an assignment to draw up a program

for its phased improvement called MSIP (Multi-Staged Improvement Program). Such a program was presented in 1987 and implementation of its first-phase engineering development plan essentially began in August 1988, for which \$25 million were allocated in the FY 1988 budget.

The primary objective of the MSIP is to increase the AH-64A's combat effectiveness and expand the range of its missions while simultaneously increasing reliability and survivability (Fig. 2). The first and one of the most important tasks is considered to be ensuring the possibility of engaging airborne targets. The foreign press reports that McDonnell Douglas has been working for several years now under a separate \$10 million contract with the objective of outfitting the helicopter with Stinger air-to-air guided missiles beginning in 1989. Devices for interfacing the missile guidance system with the helicopter fire control system and wing hardpoints in addition to the four existing ones have been developed

Fig. 2. Basic measures for improving the AH-64A Apache helicopter

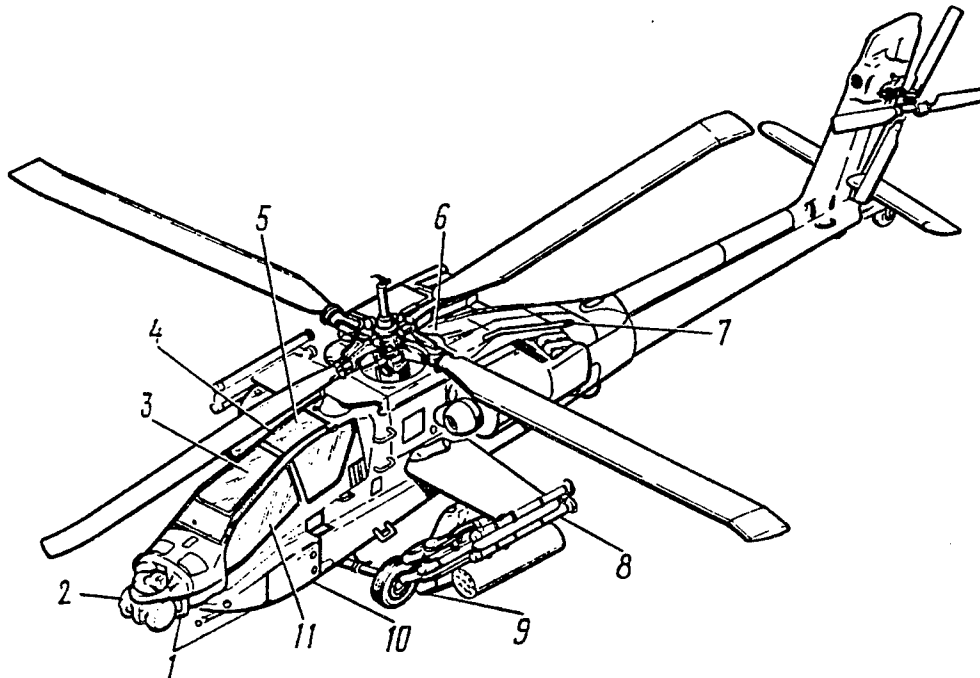

Key:

1. Advanced software equipment
2. Modernized TADS/PNVIS electro-optical sighting-navigation system
3. Advanced flight control system
4. Digital terrain map and upgraded IHADSS integrated helmet display and sighting system
5. Integrated cockpit equipment using multifunction indicators and voice signaling
6. Advanced navigation equipment using NAVSTAR system sensors
7. More powerful engines
8. Air-to-air guided missiles (Stinger)
9. Upgraded Hellfire ATGM
10. Gear for protection against the effect of electromagnetic pulse and for data transmission and recording
11. Digital communications gear and upgraded onboard troubleshooting equipment

for their use. The Stinger guided missiles will be accommodated in two twin launchers at the wingtips.

In addition to implementing the plan for arming the helicopter with Stinger missiles, a study is being made of the possibility of employing air-to-air and other types of missiles from it, particularly the Sidewinder AIM-9. The western press has noted that the first two launches of this guided missile were in November 1987 at the U.S. Army White Sands Missile Range in New Mexico, the first in a hover mode and the second in level flight at a speed of 150 km/hr (Fig. 3 [figure not reproduced]). The missile's separation from the helicopter and the compatibility of its IR homing head with the onboard weapon control system were checked during the tests, which American specialists evaluate as successful. In 1988 it was also planned to examine the possibility of employing the French-produced Magic R.550 and the Hellfire ATGM for combating airborne targets from this helicopter, with UH-1 Iroquois multipurpose helicopters and A-7 Corsair attack aircraft used as such targets. In addition, it is planned to increase the effectiveness of the helicopter's 30-mm gun in firing against airborne targets.

The second important direction in the AH-64A improvement program is an increase in its survivability and capabilities in engaging ground targets. In this connection the question is being considered of outfitting the helicopter with improved Hellfire ATGM's with thermal imaging and combination (passive radar and IR) homing heads providing realization of the "fire and forget" concept; with advanced ATGM's; and with Sidewinder AGM-122A antiradiation guided missiles (a modified Sidewinder guided missile with radar homing head in place of the IR homing head). This missile was launched from an AH-64A helicopter in April 1988.

In addition to these measures, a large amount of work in other directions also is planned. According to a statement by the program director, the primary directions include outfitting crew member work stations with integrated equipment, using standardized advanced software equipment, increasing the pilot's field of view by reconfiguring the cockpit, interfacing onboard equipment with NAVSTAR satellite navigation system sensors, using an advanced flight control system, upgrading equipment for communications at extremely low altitude, installing readouts for employing improved Hellfire ATGM's and air-to-air guided missiles, modernizing electro-optical and other onboard equipment, installing more powerful engines and reducing operating cost.

Some of the technical solutions which can be included in the first phase of the MSIP were worked out by McDonnell Douglas jointly with other companies on an initiative basis, for which over \$50 million were spent in the period 1985-1987. In particular, the base configuration of the crew cockpit was specified. It will have advanced glazing, two multifunction indicators with contiguous screens, and an alphanumeric control keyboard; instrument scale cursors will be controlled from the helicopter cyclic stick and data will be input using cassettes. It is

believed that this will ensure commonality of operator and pilot work stations and the possibility of any crew member controlling the helicopter and weapons if necessary.

The base structure of electronic equipment is being developed with consideration of long-term prospects for operating the helicopter, which will permit introducing new technical solutions as they are worked out (right up to the year 2000) and thereby constantly augmenting its capabilities. It is planned to use a Delco Magic-5 as the main computer and its programs will be compiled in ADA language. Its working memory capacity (192K words) and speed are triple that of the existing computer. In addition, a processor distribution system joined by the MIL-STD-1553B data bus will be used.

In October 1987 the Department of the Army transferred two AH-64A helicopters to McDonnell Douglas for tests of new onboard systems and equipment as well as for working out the employment of air-to-air missiles from the helicopter.

In connection with the large volume of work under the MSIP, the above firm now is determining subcontractors for its realization. According to announcements by the journal DEFENSE, the following 12 firms are the main ones selected by the middle of this year: Delco Electronics (developing the central computer in accordance with MIL-STD-1750A and the weapon control system processor), General Electric (advanced electronic flight control system), Canadian Marconi (voice signaling, voice control and data transmission gear), Lear Siegler (gear for data transmission between onboard systems and for recording flight data necessary for evaluating mission performance and helicopter maintenance), Leach Corporation (power sources control system), Martin Marietta (increasing the capabilities of the TADS/PNVIS electro-optical sighting-navigation system and advanced surveillance gear), Parker Bertie Aerospace (members with mechanical components of the electronic remote flight control system, including main and tail rotor servos), Simmonds Precision (stabilizer actuator with direct drive from electronic remote flight control system), Singer (Doppler sensors for the improved navigation system), Sperry Aerospace Group (crew cockpit indication and display equipment), Honeywell (inertial navigation gear and IHADSS improved integrated helmet display and sighting system), and Harris Corporation (image generator for digital terrain map color display).

It is planned to begin flight tests of the helicopter, designated the AH-64B, at the end of this year. It is presumed that a significant portion of improvements planned to be introduced in this helicopter will be used in modernizing the AH-64A Apache. At the present time 675 such helicopters already have been purchased, of which over 450 have been delivered to the Army. Appropriations are being requested in FY 1990 for acquiring another 72. By 1994 the U.S. Department of the Army is counting on receiving some 860 Apache helicopters of

the first modification, after which (with consideration of the overall Army requirement of 1,000-1,200 helicopters) deliveries of the AH-64B modification will begin.

COPYRIGHT: "Zarubezhnoye voyennoye obozreniye", 1989.

Field Artillery Target Acquisition Radars

904Q0001F Moscow ZARUBEZHNOYE
VOYENNOYE OBOZRENIYE in Russian
No 8, Aug 89 (signed to press 23 Aug 89) pp 26-30

[Article by Col V. Savrasov]

[Text] NATO armies devote much attention to upgrading existing reconnaissance equipment and creating new equipment, among which radars hold an important place. They are used for detecting moving airborne and ground targets; for fixing and determining coordinates of the locations of firing field artillery pieces, mortars and multiple launch rocket systems [MLRS]; and for accomplishing other missions. Radars for fixing locations of firing artillery pieces and mortars began to be employed in the U.S. and British armies back at the end of World War II. Basically these were modified AAA fire control radars.

In the early 1950's foreign specialists began developing the first specialized field artillery target acquisition radars. For example, the United States created the AN/MPQ-10 radar for detecting firing mortars. U.S. ground forces were supplied with 485 such radars up to 1954. The AN/MPQ-10 (Fig. 1 [figure not reproduced]) operates in the 2,740-2,980 MHz band. Its operating principle is based on tracking of a flying artillery or mortar projectile in the initial portion of its flight trajectory. It is possible to locate a firing position on a minimum of two rounds. Later this radar was replaced by the AN/MPQ-4 and its modernized version, the AN/MPQ-4A (Fig. 2 [figure not reproduced]), which were developed by General Electric. In addition to the U.S. Army, they are in the inventory of armies of the FRG, Denmark and Sweden; in Japan the radar is produced under license and is designated the "92."

The AN/MPQ-4A operates in the 2 cm waveband and supports detection of an 81-mm firing mortar at a distance up to 10 km with an accuracy of 40 m. It takes 4-5 minutes from the moment a mortar round is detected until friendly artillery opens fire. The radar includes an antenna system, transceiver, computing device, control unit with indicators, and power supply unit.

The principle of determining coordinates of firing mortars using this radar consists of detecting the flying mortar round and measuring its coordinates at two points. This is done by successively lining up indicator screen hairlines with target returns and inputting them to an analog computer. Based on these data and time between the appearance of the two returns, determined using an electronic counter, the computing unit outputs

firing position and ammunition burst location coordinates in digital form to the instrument scales.

The radar gear is mounted on two single-axle trailers. The radar proper is accommodated on one and a diesel generator and boxes of spare parts are mounted on the other. It takes 15 minutes to deploy the radar.

During troop operation the first field artillery target acquisition radars demonstrated higher effectiveness in detecting positions of firing pieces in comparison with flash-ranging and sound-ranging equipment, but substantial drawbacks were uncovered: low mobility, poor operator protection, insufficient detection range and accuracy in fixing firing positions, a long time for issuing data, and insufficient antijam capability.

The British firm of Thorn EMI developed the FA No 8 Green Archer field artillery target acquisition radar in the early 1950's. It is similar in operating principle to the U.S. AN/MPQ-4A. The radar is mounted on a U.S. M113 tracked APC (Fig. 3 [figure not reproduced]) to improve mobility and operator protection against small arms fire and artillery and mortar round fragments. According to foreign press reports, this radar is in the inventory of the armies of a number of West European countries including the FRG.

This same firm created a new field artillery target acquisition radar, the FA No 15 Cymbeline with a range of 20 km, in the 1960's. Its weight is several times less than that of the FA No 8 Green Archer radar thanks to the use of miniature parts. The radar is equipped with a remote control panel which can be removed to a distance up to 15 m, providing lesser likelihood of operators being hit. The Cymbeline radar also is adapted for registration of friendly artillery pieces and for battlefield surveillance.

The radar antenna system is made in the form of a parabolic reflector illuminated by a mechanical Foster scanner. Such a design permits shaping the beam as a double sheaf one above the other, which ensures detection of all flying mortar rounds intersecting this beam. It is 25° wide in the horizontal plane and there is a 2° between-sheaf angle in the vertical plane. The radar's surveillance zone can be expanded to 180° by mechanically rotating the antenna. The time for processing incoming data and determining mortar locations does not exceed 15 seconds.

The FA No 15 Cymbeline radar has become widespread (over 300 have been produced) and presently is in the inventory of armies of Great Britain, Norway and Sweden as well as a number of other countries of Western Europe, Asia and Africa. The British Army uses two versions: transportable and mobile, mounted on the Trojan tracked APC (Fig. 4 [figure not reproduced]).

The foreign press reports that this radar has been modernized in recent years. In particular, receiver sensitivity has been increased by using field-effect transistors in the

amplification stages and antijam capability has been improved by installing a moving target indication system.

The U.S. AN/TPQ-36 and -37 radars, which can be used either individually or together, appeared as a result of further development of field artillery target acquisition radar equipment. When used together they form the Firefinder field artillery target acquisition system, permitting determination of position coordinates of firing tube and rocket artillery.

The AN/TPQ-36 radar (Fig. 5 [figure not reproduced]) was created by the American firm of Hughes Aircraft in the late 1970's. It was under development for eight years. The radar is intended for detecting mortar positions at distances to 16 km. It is being delivered to the ground forces to replace the AN/MPQ-4, -4A and -10 radars. In addition to the United States, this radar has been purchased by Australia, Jordan, the Netherlands, Pakistan, Saudi Arabia and Thailand.

The fundamental distinction of the AN/TPQ-36 from previous radars with a similar purpose is the use of an antenna system in the form of a phased array which provides for electronic scanning by the sounding beam (frequency scanning in elevation and phased scanning in azimuth). The phased array forms a single-sheaf radar barrier by rapid displacement of the needle-shaped sounding beam in a 90° sector in the horizontal plane. When a flying target (mortar or artillery round) is detected, it is momentarily tracked in the vertical plane. The maximum beam elevation angle is 45°. The radar's azimuth search sector is 360° by mechanically rotating the phased array in the horizontal plane. Equipping the radar with a computer permitted fully automating the process of determining the coordinates of firing weapons. There is a capability of simultaneously fixing some 40 firing positions. The time for position fixing does not exceed the time of a mortar round's flight to the target.

The pulse-Doppler method of radio detection and ranging used in the radar ensures effective suppression of signals reflected from the Earth and clouds and suppression of passive jamming. Troubleshooting time has been reduced to 15 minutes thanks to a built-in functional monitor system.

The radar gear is accommodated in a container (with signal processing and radar operation control units) carried by a two-and-one-half ton truck, and on a trailer (antenna system with transceiver). It is powered from a diesel generator on the vehicle.

This radar's high mobility permits its use not far from the front line, but no closer than 2 km. Radar setup time is not over 15 minutes and it takes 5 minutes to shift from a deployed to a traveling configuration. Three AN/TPQ-36 radars are attached to each U.S. division field artillery non-visual target acquisition battery. The radar combat team numbers eight persons.

The AN/TPQ-37 radar (Fig. 6 [figure not reproduced]) was developed for detecting and determining the coordinates of positions of firing field artillery pieces and MLRS at distances to 40 km. It is similar to the previous radar in design and operating principle, but in contrast to the AN/TPQ-36 it uses a phased method of controlling the sounding beam in both planes. Target detection range was increased basically by using a more powerful transmitter.

Radar equipment is housed in a container carried by a half-ton vehicle. The antenna system is installed on a trailer and towed by a five-ton truck, the body of which mounts a 60 kw diesel generator. The radar combat team is 8-12 persons.

In combat use the radar is deployed behind AN/TPQ-36 radar positions at a distance of up to 10 km from the front line.

A total of over 150 AN/TPQ-36 and some 70 AN/TPQ-37 radars have been delivered to the U.S. Army. These radars also are being produced under license in the FRG.

The J/MPQ-P7 field artillery target acquisition radar (Fig. 7 [figure not reproduced]) developed by Toshiba in the mid-1980's is becoming operational with the Japanese Army. It utilizes many technical solutions of the U.S. AN/TPQ-36 and -37 radars, including electronic scanning by a sounding beam using a planar phased array.

Along with obvious advantages, the AN/TPQ-36, AN/TPQ-37 and J/MPQ-P7 radars also have a number of deficiencies; in particular, they are cumbersome and insufficiently protected against the effect of EW assets. According to foreign press reports, some of these deficiencies are to be eliminated in the improved Firefinder-2 system being created by the American firm of Hughes Aircraft. It will use modernized AN/TPQ-36 and -37 radars.

West European countries also intend to develop new equipment for detecting field artillery firing positions. For example, in 1986 Great Britain, the FRG and France decided to jointly develop the COBRA (Counter Battery Radar). To ensure necessary mobility it is proposed to house the radar gear in a three-axle or four-axle vehicle (Fig. 8 [figure not reproduced]). The radar will have a planar phased array. It is planned to include modern means of protection against active and passive jamming in the radar along with a high capacity data processing system. The radar will be equipped with an automatic topographic survey system and gear for interfacing with the BATES, (UK), ADLER (FRG) and Atila (France) automated fire control systems.

Radar development has been assigned to an association of firms: West German Siemens, UK Thorn EMI, French Thomson-KSF and American General Electric. The latter is considered the leader in the field of gallium arsenide technology, which presently is widely used in

creating phased arrays. Tentative program cost is £500 million. According to foreign press announcements, the radar will be attached to division and corps field artillery non-visual target acquisition subunits. Under combat conditions it is proposed to situate the radar up to 15 km from the front line and use it basically for fixing the firing positions of long-range artillery and MLRS.

In 1988 the Swedish firm of Ericsson began developing the Artur field artillery target acquisition radar. The Norwegian firm of Nordic Electronics Systems intends to participate in this project as a subcontractor. The Artur antenna system is to be made in the form of a phased array as in the COBRA radar. Radar equipment will be accommodated on a Bv-208 tracked prime mover and a single-axle trailer. Tests of the Artur are planned for the early 1990's, after which it is to become operational with armies of Sweden and Norway.

In addition to using specialized field artillery target acquisition radars, NATO armies also conduct radar reconnaissance of field artillery and mortar positions using long-range and medium-range ground surveillance radars. The latter include in particular the U.S. AN/TPS-33, the Franco-West German Ratac and the West German Ratac-S.

COPYRIGHT: "Zarubezhnoye voyennoye obozreniye", 1989.

AIR FORCES

New Things in Combat Training of USAF SAC Air Forces

904Q0001G Moscow ZARUBEZHNOYE
VOYENNOYE OBOZRENIYE in Russian
No 8, Aug 89 (signed to press 23 Aug 89) pp 31-35

[Article by Col A. Alekseyev]

[Text] New political thinking initiated by the Soviet leadership in the nuclear space age convinces us of the absence of an alternative to joint coordinated decisions and actions for strengthening mutual and general security, and of the need to reject military power moves and the militarization of international relations. With the existing strategic arms parity between the USSR and United States and the balance of Warsaw Pact and NATO general-purpose forces, real prospects for strengthening peace lie in shifting from confrontation to comprehensive cooperation based on principles of peaceful coexistence. A substantial contribution to such a normalizing process can be made by adoption of a defensive military doctrine and strategy by all great powers, reduction of armed forces and weapon stockpiles to the level of reasonable sufficiency for defense, reduction in dangerous military activity, and settlement of problems that arise exclusively by means of talks.

But new approaches to relaxing the military confrontation that is fraught with danger are having a difficult

time making their way. The Soviet Union and other Warsaw Pact member states officially promulgated their defensive military doctrine, they are reducing armed forces on a unilateral basis, they made changes to military organizational development plans, they are revising the structure of large and small units, and they have reoriented the system of training for command cadres and troops. At the very same time American strategists and their allies, including those in NATO, continue to seek signs of a so-called "Soviet military threat" and they tentatively depict asymmetry in some kinds of arms as a USSR superiority, silently ignoring the product list of attack weapons in which they have indisputable advantage. The United States and NATO are elaborating new concepts, building up the offensive potential of armed forces, nurturing plans for modernizing tactical nuclear weapons, and broadening the scale of operational and combat training.

There are more than enough examples of this. One is USAF SAC exercises, which have drawn attention by their novelty, odious names, objectives, scope, and nature of missions rehearsed. It is a matter of a new type of exercise in which aircraft of the USAF SAC Air Forces with conventional weapons are involved: 8th Air Force in Mighty Warrior-88 and 15th Air Force in Giant Warrior-89.

A proposal to train not only individual strategic bomber aviation units and subunits for use in a conventional war, but also all aviation of SAC air forces was advanced by SAC representatives in late 1987 and was sanctioned by the American leadership.

The 8th and 15th air forces are the two main groupings of USAF SAC forces and assets; they have concentrated strategic land-based missile forces (ICBM's) and strategic aviation—bomber, reconnaissance, tanker—in their makeup. The large and small units and subunits of 8th Air Force are stationed in central and eastern states of the continental United States as well as at forward airfields in the European and Atlantic Ocean zones. The headquarters of this Air Force is stationed at Barksdale AFB, Louisiana. Components of 15th Air Force (headquarters at March AFB, California) also are dispersed in the central and western United States and extensively use a system of forward aircraft basing in the Western Pacific.

According to foreign press announcements, the strategic aviation effective combat strength and active reserve, distributed between the 8th and 15th air forces, numbers 419 heavy and medium B-1B, B-52G and H as well as FB-111A bombers; 68 TR-1, SR-71, RC-135, and U-2 reconnaissance aircraft; and 525 KC-10 and KC-135 tanker aircraft (in addition the U.S. Air National Guard and the Air Force Reserve have another 128 KC-135 aircraft). Organizationally the aircraft fleet of strategic aviation is consolidated in heavy bomber, medium bomber, reconnaissance and air refueling wings which are part of air divisions or are directly subordinate to the air force commanders. A type version of the heavy

bomber wing includes one or two squadrons of heavy bombers (14 B-52 or 16 B-1B each) and one or two air refueling squadrons.

These data provide a sufficiently complete idea of the SAC air grouping's attack potential both with nuclear and conventional weapons. The question of combat employment of heavy bombers with conventional weapons is not new. Their dual purpose took shape from World War II times. In the assessment of American specialists based on the experience of local wars in Korea (1950-1953) and Southeast Asia (1965-1973), the intercontinental flight range, considerable combat payload, and capability of quickly redeploying to any area of the world and operating day or night in adverse weather conditions predetermine the exceptional role of strategic bombers in non-nuclear wars. Their recognition as a highly effective means of supporting general-purpose forces in continental theaters is reflected in the "strategic zone of responsibility" concept being elaborated by the USAF SAC command, and the same role in ocean and sea theaters is reflected in the theory and practice of preparing air-sea operations.

The new concept envisages concentrated efforts of a grouping of strategic bombers made operationally subordinate to the CIC of U.S. theater forces in accomplishing the priority mission of interdiction. The CIC determines limits of bomber "zones of responsibility" beyond the range of tactical aircraft. Enemy second echelons and reserve forces, transportation hubs, supply depots, airfields and so on can be designated strike objectives in the zone. American military theorists believe that bomber aviation thus will be able to realize its advantages in range and powerful combat complement and create favorable conditions for tactical aviation to accomplish missions of close air support to ground forces, of winning air superiority, and of interdiction.

The U.S. command's fundamental views on air-sea operations are set forth in Air Force Manual AFM 1-1, "Basic U.S. Air Force Aerospace Doctrine" (1984). According to this document, USAF SAC heavy bombers are called upon to support the American Navy by delivering Harpoon antiship missile strikes against enemy ships and vessels, by minelaying off enemy bases and ports, by conducting reconnaissance of ocean areas, and by providing over-the-horizon target designation.

The objective of exercises Mighty Warrior-88 and Giant Warrior-89 was a comprehensive check of combat readiness of 8th and 15th air forces' strategic aviation to accomplish missions in a conventional war in its own zones of operation as well as a practical rehearsal of provisions of the "strategic zone of responsibility" and "air-sea operation" concepts as part of air force groupings.

The 8th Air Force Exercise Mighty Warrior-88 was held in July 1988. It lasted around two weeks and took in the continental United States, Western Europe and the

Atlantic Ocean zone. The situation of an outbreak of a local armed conflict in Southwest Asia and its escalation to the scale of conventional war in Europe and in the Atlantic was played out under the scenario. The U.S. press directly pointed out the fact that the practical background of this exercise largely copied the game situation of NATO's Wintex/Simex-87 Allied Forces strategic command and staff exercise (held once every two years).

Seven B-52 heavy bombers and seven FB-111A medium bombers from each of nine heavy and medium bomber wings of 8th Air Force and 4-8 tanker aircraft from each bomber and air refueling unit of 8th Air Force were included in the exercise. A total of 63 bombers, 54 tanker aircraft and over 4,000 servicemen participated. This operational measure primarily consisted of a rehearsal of the following missions:

- Organizing a shift of command and control entities and large and small units from a peacetime to a wartime footing;
- Building up the makeup of combat-ready strategic aviation forces and assets;
- Reinforcing forward groupings of bomber and tanker aircraft (simulated by the use of Fairford Air Base in Great Britain) and reconnaissance aircraft;
- Dispersing aircraft to alternate airfields, including SAC, Tactical Air Command, Navy, Army Aviation, Air National Guard and civilian airfields;
- Perfecting tactics of penetrating enemy air defense and delivering missile and bomb attacks against ground and naval targets;
- Organizing combat command and control of air force aircraft, coordination of the SAC and 8th Air Force commands with commanders in chief of U.S. Armed Forces in the zones, coordination of strategic aviation with USAF tactical aviation and naval forces, as well as combat and logistic support.

USAF SAC CIC Gen J. Chain exercised overall direction of the exercise, and 8th Air Force CIC Lt Gen E. Shuler exercised immediate direction.

Foreign commentary on this exercise noted that it was the largest SAC operational and combat training activity using conventionally armed strategic bombers since the time of the American aggression in Vietnam. The intensity of air operations consisted of 6-10 sorties by an air wing per day. In the majority of cases B-52's were employed in groups of seven supported by seven tanker aircraft. Target approaches were from different directions at low altitude under conditions of total radio silence, primarily at night. During two days of the active exercise phase, bomber crews of the 42d Heavy Bomber Wing (Loring AFB, Maine) denoted combat operations involving the sides' use of chemical weapons. Practice bombing was performed at ranges of the United States, Great Britain, the FRG and the Netherlands. A B-52

launched a Harpoon antiship missile in the North Atlantic. Support and maintenance subunits of SAC units drilled intensively in preparing unimproved airfields and strips to receive strategic bombers, actually performing the work of grading terrain, constructing tent facilities and depot spaces, organizing communications, providing water and power, and so on.

Special attention during the exercise was given to strategic air crews' mastery of the European theater of war. The USAF journal AIR FORCE TIMES asserted that strategic aviation can count on using up to 45 airfields there as well as the airfield network of non-European states for landings after execution of combat missions. This journal cites as an example a variant of an American bomber sortie from a UK air base, delivery of strikes against enemy targets, a landing at an airfield in Turkey, refueling, suspension of another ordnance payload, delivery of subsequent strikes, landing in another country, and so on.

The scope and intensity of Exercise Mighty Warrior-88 are characterized by the following data published in the U.S. military press: bombers from nine air wings which took part flew 509 sorties and conducted practice bombing against 16 targets on territories of the United States and West European countries. In wartime they could take up around 25,000 M117 aerial bombs. It is apropos to recall that during World War II American aviation dropped 2,057,000 tons of bombs on fascist Germany and its ally Japan. USAF SAC tanker aviation flew 343 sorties and made 1,083 air refuelings in the process of supporting the forces brought in for this exercise.

A similar exercise, Giant Warrior-89, by aircraft of USAF SAC 15th Air Force was held during March-April 1989 on U.S. territory including Alaska and in zones of the Pacific and Indian oceans. It had the very same direction and duration and the very same scope of missions with specifics of the above theaters taken into account. The forces and assets used consisted of 60 B-1B and B-52 bombers, a considerable grouping of tanker aviation, and over 1,500 personnel. Immediate direction of the exercise was the responsibility of 15th Air Force CIC Lt Gen R. Burpee.

Several points are noted in connection with this exercise. First of all, the bulk of strategic aircraft deployed at forward airfields—Elmendorf and Eielson in Alaska and Andersen on Guam, and flew operational training missions from them. American observers noted that it was the first time since the end of the war in Vietnam that such an impressive grouping of heavy bombers had been created in the Western Pacific. Such measures hardly can be categorized as "forward defense," since bomber aviation is recognized as an offensive component in all world countries. Secondly, the date of Giant Warrior-89 coincided with Exercise Team Spirit-89, the largest joint U.S.-South Korean exercise in the Far East, and with Brim Frost-89, a U.S. Armed Forces exercise in Alaska, and was organized in close coordination with the U.S.

Air Force and the U.S. Unified Central Command, i.e., with the notorious Rapid Deployment Force. Thus the 15th Air Force exercise became evidence of large-scale U.S. military preparations in the Asiatic-Pacific region. Thirdly, during the exercise both USAF SAC air forces formed an enormous arc around the Soviet Union and other states of the socialist community and thereby simulated a threat from the western, eastern and southern directions.

An expansion of the scale of USAF SAC strategic aviation exercises and the U.S. command's intention to conduct them henceforth on a regular basis in no way jibe with statements made by this country's leadership about the defensive nature of national military doctrine.

The question arises in connection with the above: How serious is the threat from armadas of heavy bombers in a conventional war? The viewpoint is widespread among military specialists of the United States and the West that strategic bombers are exclusively nuclear weapon platforms and the experience of their combat employment with conventional weapons in past wars is refuted. Supporters of such views give the priority in a conventional war to tactical aviation, the Navy, and the Army.

Here is the official opinion of USAF SAC CIC Gen G. Chain: "Heavy bombers with the capability of concentrating firepower accurately on selected targets can play an important and actually a potentially deciding role in a conventional armed conflict in a theater." The general further elaborates his thought by emphasizing that technical progress in aviation and its armament (an increase in range, speed and combat payload; outfitting with EW assets; and an increase in the accuracy and power of weapons, and guided weapons above all) leads to an increase in combat effectiveness and an obliteration of traditional distinctions between strategic (heavy, long-range) and tactical (such as fighter) aircraft.

In other statements and assessments by U.S. air experts one can find explanations which essentially reduce to the fact that the key role of heavy bombers in a conventional war will consist of support to general-purpose forces—ground forces, tactical aviation and the fleet. They have all necessary qualities for this. For example, B-52G and H bombers are capable of covering a distance of from 12,000 to 16,000 km without aerial refueling (at low altitudes the tactical radius is around 2,000 km) and can be moved to essentially any part of the world within 24 hours. In conducting combat operations with conventional weapons, the onboard weapons can include high-explosive bombs, various types of aircraft cluster munitions, AGM-84 Harpoon antiship missiles, and naval mines depending on assigned missions. Bombers can carry 18-51 Mk 84 (2,000 pound), M117 (750 pound) and Mk 82 (500 pound) aerial bombs, or 30-51 GBU-87, GBU-89 (with antitank mines) and GBU-52 cluster bombs, or 12 Harpoon antiship missiles, or 18-51 Mk 60 Captor, Mk 52 and Mk 36 naval mines on internal and external mountings.

Heavy bomber combat capabilities can be increased considerably in the future by receiving long-range cruise missiles with conventional warheads, precision munitions based on Skeet impact shot, combination effect clusters, Have Nap missiles, Tacit Rainbow antiradiation missiles and so on. In the assessment of the U.S. command, the accuracy of air navigation and of delivery of weapons to targets will double with deployment of the NAVSTAR navigational system compared with that achieved at the present time. Protection of bombers against air defense forces and assets is to be increased by including HARM antiradiation missiles and AMRAAM air-to-air missiles in the onboard weapon mix.

Thus the improvement in weapons of conventionally armed USAF SAC heavy bombers, development of new concepts and tactics of operations, an expansion in the scope of exercises to the air force level, and plans for forming a T/O&E grouping of strategic bomber aviation with a so-called "non-nuclear status" (consisting of 68 B-52G aircraft not refitted for cruise missiles) by the late 1980's attest to the planned, purposeful preparation of this kind of aviation for participation not only in a nuclear war, but in a conventional war as well.

COPYRIGHT: "Zarubezhnoye voyennoye obozreniye", 1989.

Electromagnetic Pulse of a Nuclear Burst and Protecting Electronics Against It

904Q0001H Moscow ZARUBEZHNOYE
VOYENNOYE OBOZRENIYE in Russian
No 8, Aug 89 (signed to press 23 Aug 89) pp 35-41

[Article by Col D. Figurovskiy, candidate of technical sciences]

[Text] Despite the U.S. and NATO military-political leadership's admission of the impossibility of victory in a nuclear war, various aspects of the damage and casualty effect of nuclear weapons continue to be discussed widely in the foreign press. For example, one scenario of the initial period of nuclear war being examined by foreign specialists sets aside a special place for the potential capability of knocking out electronic equipment by the effect of a nuclear burst's electromagnetic pulse [EMP]. It is believed that detonating just one weapon of over 10 megatons at an altitude of around 400 km will disturb the functioning of electronics in a vast area and that their restoration time will exceed permissible time periods for taking retaliatory measures.

According to calculations by U.S. military experts, the optimum point for detonating a nuclear weapon in order to have electronics on almost all U.S. territory affected by EMP would be a point in outer space with epicenter near the country's geographic center in the state of Nebraska (Fig. 1). It is assumed that even if communications and power lines as well as ground and airborne electronic equipment had presently known means of protection against EMP, the latter's effectiveness can be so high as to threaten the capability of strategic forces to

Fig. 1. EMP effect zones from a nuclear burst at an altitude of 300 km with epicenter at the geographic center of the continental United States

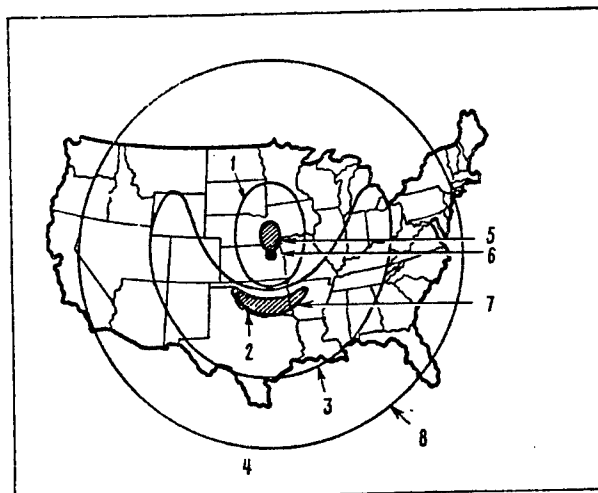

Key:

1. Field intensity equal to 0.5 of maximum value
2. Maximum field intensity
3. Field intensity equal to 0.75 of maximum value
4. Field intensity equal to 0.5 of maximum value
5. Burst epicenter
6. Geographic center of the country
7. Area of maximum field intensity
8. Horizon line from burst height

deliver a retaliatory strike. This circumstance is explained by the fact that with the existing level of knowledge about this damage and casualty factor it is impossible to determine with absolute accuracy the degree and probability characteristics of disturbances it causes.

Theoretical studies and results of physical experiments show that the EMP from a nuclear burst can lead not only to outage of semiconductor electronic devices of military equipment, but also to the destruction of metal conductors of cables at ground facilities. In addition, damage to the gear of satellites in low orbit is possible.

To generate EMP a nuclear weapon can be detonated in outer space, which does not lead to the appearance of a blast wave or to radioactive fallout. Therefore the foreign press expresses speculative opinions about the "non-nuclear character" of such a tactical use of nuclear weapons and that an attack using EMP will not lead to general nuclear war without fail. The danger of these statements is obvious especially since some foreign specialists at the same time also do not exclude the possibility of mass destruction of personnel by EMP. In any case, it is quite obvious that currents and voltages induced in metal components of equipment under the effect of EMP will be fatal for personnel.

In order to understand the full complexity of the problem of EMP threat and measures for protection

against it, it is necessary to briefly describe the history of this physical phenomenon's study and the present status of knowledge in this sphere.

The fact that a nuclear burst will certainly be accompanied by electromagnetic radiation was clear to theoretical physicists even before the first test of a nuclear device in 1945. The presence of EMP was registered experimentally during nuclear explosions in the atmosphere and outer space conducted in the late 1950's and early 1960's, but the pulse's quantitative characteristics were measured to an insufficient extent. First of all this was due to an absence of monitoring and measuring equipment capable of registering extremely powerful electromagnetic radiation existing for an extremely short time (millionths of a second), and secondly because in those years electronic gear exclusively used vacuum electronic devices little subject to the effect of EMP, which reduced interest in its study.

The creation of semiconductor devices and then also integrated circuits (especially digital technology devices based on them) and their wide introduction to military electronics forced foreign specialists to assess the threat of EMP anew. Since 1970 questions of protecting weapons and military equipment against EMP have begun to be considered by the U.S. Defense Department as a high priority. This was a result of theoretical discoveries made in the early 1960's in the sphere of interaction with the atmosphere by factors of a nuclear burst leading to a sharp increase in electromagnetic radiation.

As follows from foreign press materials, the mechanism of EMP generation consists of the following (Fig. 2). Gamma rays and x-rays arise during a nuclear burst and a neutron flux forms. Interacting with molecules of atmospheric gases, gamma radiation dislodges so-called Compton electrons from them. If the explosion takes place at an altitude over 20-40 km (depending on geographic latitude), then these electrons are captured by the Earth's magnetic field and, rotating relative to this field's force lines, create currents which generate EMP. The EMP field accumulates coherently in the direction toward the Earth's surface, i.e., the Earth's magnetic field fulfills a role similar to a phased array. As a result there is a sharp increase in field intensity and consequently in EMP amplitude in areas south and north of the burst's epicenter (see Fig. 1). The length of this process from the moment of the explosion is from 1-3 to 100 nanoseconds.

In the next stage, lasting from approximately 1 microsecond to 1 second, the EMP is created by Compton electrons dislodged from molecules by multiple-reflection gamma radiation and because of the inelastic collision of these electrons with the flux of neutrons given off during the explosion. EMP intensity here is approximately three orders of magnitude lower than in the first stage.

Fig. 2. Physical phenomena of EMP generation

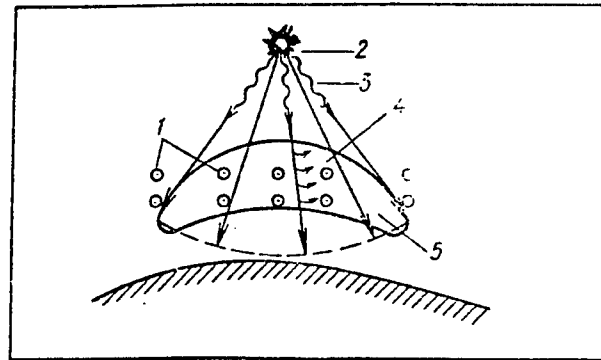

A

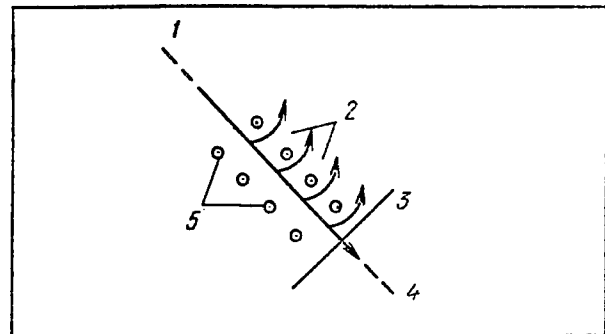

B

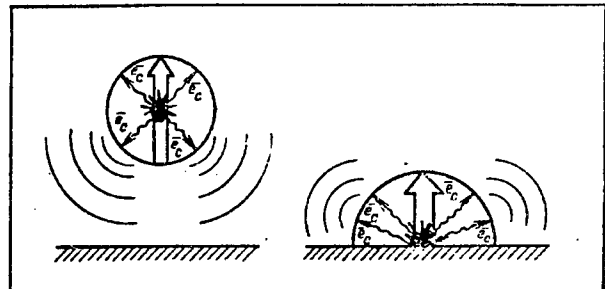

C

- Key:
- A. EMP generation from explosion in outer space
 1. Force lines of Earth's magnetic field
 2. Point of explosion
 3. Gamma radiation of explosion
 4. Compton electrons
 5. Zone of EMP appearance at altitude of 20-40 km
 - B. EMP self-focusing mechanism
 1. To point of burst
 2. Elementary currents adding in phase as wave front moves toward Earth's surface
 3. Gamma flux front
 4. To Earth's surface
 5. Force lines of Earth's magnetic field
 - C. EMP generation in air and surface bursts
 1. Symmetrical vertical fields form from high air burst because of even propagation of electrons in the burst sphere
 2. Great asymmetry of electron propagation is seen in surface burst because of proximity of Earth's surface

In the final stage, occupying a period in time after the explosion of from one second to several minutes, EMP is generated by the magnetohydrodynamic effect arising from perturbations of the Earth's magnetic field by the current-conducting fireball of the burst. EMP intensity in this stage is very low and is several tens of volts per kilometer.

The first stage of EMP generation is believed to represent the greatest danger for electronic equipment. In accordance with the law of electromagnetic induction, because of the extremely rapid growth in pulse amplitude (the peak is reached 3-5 nanoseconds after the burst), induced voltage in this stage can reach tens of kilovolts per meter at the level of the Earth's surface, dropping smoothly away from the burst epicenter.

Although EMP amplitudes are given in Fig. 1 only within limits of the geographic horizon corresponding to a burst altitude of 300 km, pulse effect can propagate far beyond its limits because of the phenomenon of refraction. This phenomenon has an irregular nature, however, and so cannot be considered with sufficient accuracy.

The amplitude of voltage induced in conductors by EMP is proportionate to the length of the conductor in its field and depends on the conductor's orientation relative to the electric-field vector. The foreign press gives the following example in this connection: electric-field intensity of the EMP field in high-voltage power transmission lines can reach 50 kw/m, which will lead to the appearance of currents in them with a force up to 12,000 amperes.

EMP also is generated in other kinds of nuclear explosions—air and surface. It has been theoretically established that in these cases its intensity depends on the degree of asymmetry of the burst's spatial parameters. Therefore an air burst is less effective from the standpoint of EMP generation. The EMP of a surface burst will have high intensity, but it decreases quickly away from the epicenter.

The foreign press emphasizes that an absence of experimental data greatly hampers the calculation of damage and casualty factors of EMP and determination of measures to protect against it. Mathematical modeling of EMP generation processes on computers will facilitate this to a considerable extent. The result of such modeling is shown in Fig. 3 [figure not reproduced] in the form of a three-dimensional depiction of a nuclear burst in outer space. Through such modeling and based on theoretical calculations, foreign specialists have established that the intensity induced by EMP (50 kw/m) can be considered the maximum possible. This circumstance became a criterion in designing means of protection against EMP. Other criteria are the duration of the leading edge of EMP (3-5 nanoseconds) and its total duration (approximately 1 microsecond), as a result of which the time of transition processes in means of protection against EMP

must not exceed several nanoseconds and their disruptive strength must be such as to withstand voltage of tens of kilovolts for several microseconds.

With consideration of these criteria the United States has developed military standard MIL STD-2169, which is a nomogram for calculating the EMP level depending on burst height, yield, and distance of the protected object from the burst epicenter. For the standard's practical use it is necessary to know the stability of various instruments, devices and circuits to the effect of EMP of a certain intensity and the effectiveness of protective means. The problem of collecting experimental data is solved by methods and means of physical modeling inasmuch as it is technically very complicated and costly to collect such data in conducting underground nuclear tests.

The United States holds the leading position among capitalist countries in the development and practical use of nuclear burst EMP simulators. Such simulators are generators with special emitters which create an electromagnetic field with parameters close to those typical of a real EMP. The object being tested and instruments registering field intensity, frequency spectrum and effect duration are placed in the emitter's effect zone.

One such simulator, deployed at Kirkland AFB, New Mexico, is shown in Fig. 4 [figure not reproduced]. It is intended for simulating conditions of EMP effect on an aircraft and its equipment in flight and can be used for testing such large aircraft as a B-52 bomber or Boeing 747 civilian airliner.

A large number of EMP simulators presently have been created and are in operation for testing military aviation, space, ship and ground equipment. It is believed, however, that none of them recreates actual conditions of the effect of a nuclear burst EMP to the full extent due to limitations imposed by characteristics of emitters, generators and power sources on the emission frequency spectrum, its power, and the rate of pulse rise. Meanwhile the foreign press notes that even with these limitations, rather complete and reliable data are being collected on the appearance of malfunctions in semiconductor devices, failures in their functioning and so on, and about the effectiveness of various protective devices. In addition, such tests permitted a quantitative evaluation of the danger of various ways by which EMP affects electronic equipment.

Electromagnetic field theory shows that for ground equipment such ways above all are various antenna arrangements and cable lead-ins of the power supply system; for aviation and space equipment such ways are antennas as well as currents induced in the skin and radiation penetrating cockpit glass and inspection plates made of nonconducting materials. It has been theoretically calculated and experimentally confirmed that currents induced by EMP in above-ground and buried power supply cables stretching for hundreds and thousands of kilometers can reach thousands of amperes, and

voltages arising in opened circuits of such cables can reach millions of volts. EMP-induced currents can have a force of several hundred amperes in antenna lead-ins whose length does not exceed tens of meters. EMP penetrating directly through components of structures made of dielectric materials (unshielded walls, windows, doors and so on) can induce currents with a force of tens of amperes in interior wiring. Currents induced in an aircraft's skin and in an extendable VLF communications antenna can be up to 1,000 amperes, which leads to the appearance of currents with a force of 1-10 amperes in onboard interior circuits.

Inasmuch as weak-current circuits and electronic devices normally operate with voltages of several volts and with currents with a force up to several tens of milliamperes, the foreign press asserts that protecting them against EMP with absolute reliability requires reducing the values of currents and voltages induced in power supply cables by six orders of magnitude.

Ideal protection against EMP would be to completely cover the space or housing containing electronic equipment with a metal shield. Meanwhile it is clear that in a number of cases it is impossible to provide such protection practically, since in order for the equipment to operate it is often necessary to provide for its electrical contact with external devices. Therefore less reliable means of protection are used such as current-conducting grids or film coating for windows, honeycomb metal constructions for air intakes and ventilation openings, and spring-loaded contact gaskets placed around the perimeter of doors and hatches.

Protection against the penetration of EMP into equipment through various cable lead-ins is considered a more complicated technical problem. According to foreign specialists' views, a radical solution to this problem could be a shift from electrical communications circuits to fiber-optic circuits which essentially are not subject to the effects of EMP, but replacement of semiconductor devices by electro-optical devices in the entire spectrum of their functions is possible only in the distant future. Therefore filters (including waveguide filters) as well as spark gaps, metal-oxide varistors and high-speed Zener diodes presently are used most widely as means for protecting cable lead-ins.

All these means have both advantages and disadvantages. For example, capacitance-inductance filters are considered sufficiently effective protection against low-intensity EMP, while waveguide filters protect in the relatively narrow SHF band. Spark gaps have a considerable time lag and basically are suitable for protecting against overloads arising under the effect of voltages and currents induced in the aircraft skin, equipment housing and cable braiding.

Metal-oxide varistors were created relatively recently; they are semiconductor devices which sharply increase their conductivity in the presence of high voltage. It is assumed, however, that in using such devices as a means

of protection against EMP one must take account of their insufficiently high speed and deterioration of characteristics under the repeated effect of loads. These deficiencies are absent in high-speed Zener diodes, whose effect is based on an abrupt avalanche-like change in resistance from a relatively high value essentially to zero (short circuit mode) when the voltage applied to them exceeds a certain threshold value. The speed of such a process in modern Zener diodes is around 10^{-9} seconds, and the theoretical limit can reach even 10^{-12} seconds. In addition, in contrast to varistors, the Zener diode's characteristics do not deteriorate after multiple effects of high voltages and mode switches.

The foreign press notes that the most rational approach to designing means of protecting cable lead-ins against EMP is to create connectors whose construction includes special measures ensuring formation of filter components and installation of built-in Zener diodes. Such a connector was created by the firm of International Telephone and Telegraph Corporation for the Phoenix air-to-air missile (Fig. 5). One can easily see in a cross-section of the connector the attachment of Zener diodes directly to the current-conducting contact, and design components of the connector forming a frequency filter (each contact runs inside a ferrite ring which performs the role of an inductance coil, with "waffle" condensers of the filter capacitors accommodated on both sides). Such a design facilitates obtaining the very low values of capacitance and inductance necessary for ensuring protection against pulses which have slight duration and consequently a powerful high-frequency component.

It is assumed that using connectors of this design will allow solving the problem of limiting the protection device's weight-size characteristics. How important this circumstance is can be judged from the following example cited in the western press. Using conventional radio parts, a circuit of 1,024 capacitors, 512 inductance coils and 512 diodes would be required to create a device for protecting four standard connectors, each of which has 128 contacts (considered typical for modern computer equipment).

An example also is given of the practical use of new connectors in aircraft electronics. An industrial firm proposed to modify an Army helicopter for the Navy. Tests revealed that it was impossible for the helicopter to land on a carrier because onboard equipment was disabled in this situation by powerful emissions of the ship's electronic equipment. The problem was solved to a considerable extent after a number of connectors in the helicopter equipment were replaced by new ones equipped with devices protecting against EMP.

The difficulty of solving the problem of protection against EMP and the high cost of means and methods developed for this purpose forced the U.S. command at first to take the path of selectively using them in especially important weapon systems and military equipment. The first purposeful work in this direction consisted of programs for protecting Minuteman, Poseidon

Fig. 5. Cross-section of connector with built-in devices for protection against EMP

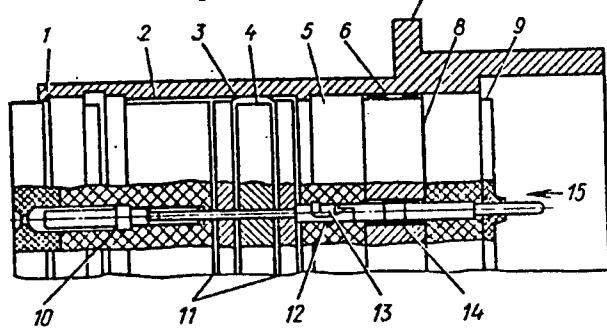

Key:

1. Connector body
2. Rear insulator
3. Grounding springs
4. Ferrite inductor
5. Central insulator
6. Annular spring-loaded contact
7. Socket
8. Grounded plate
9. Inner front jumper (obturator)
10. Contact
11. Capacitor
12. Diode contact
13. Zener diode assembly
14. Spring-loaded annular contact
15. Incoming signal

and Polaris missile systems against EMP. According to U.S. experts, these systems essentially have absolute protection. The problem is solved in nonstrategic weapon systems by providing reliable protection for devices and components most important for their functioning or subject to the effect of EMP.

The very same path also was chosen for protecting command and control and communications systems of great extent, but foreign specialists consider the primary method of solving this problem to be creation of so-called distributed communications networks (such as Gwenn), the first elements of which already have been deployed in the continental United States.

The present status of the EMP problem is evaluated by the western press as follows. Mechanisms for generating EMP and parameters of its damage and casualty effect have been rather well studied theoretically and confirmed experimentally. Equipment protection standards have been developed and effective means of protection are known. It is necessary to conduct tests using a simulator, however, to achieve sufficient confidence in the reliability of protection for systems and equipment against EMP. In particular, aircraft, missiles, satellites, individual pieces of shipboard equipment, and the equipment of communications and command and control systems already are undergoing such tests. It is assumed that capabilities for testing ship equipment will be considerably expanded after construction of the

Empress-2 simulator specially accommodated on an experimental research vessel is completed. The task of full-scale testing of communications and command and control systems hardly will be solved in the foreseeable future, according to assessments by foreign specialists.

According to foreign press announcements, it is possible to create powerful EMP from more than a nuclear burst. At the present time some western countries are working on generating pulses of electromagnetic radiation by magnetohydrodynamic devices as well as by high-voltage discharges. Therefore questions of protecting electronics against the effect of EMP will remain the focus of attention of scientific-technical specialists of NATO countries no matter what the outcome of nuclear disarmament talks.

COPYRIGHT: "Zarubezhnoye voyennoye obozreniye", 1989.

NAVAL FORCES

Antisubmarine Mine Weapons

904Q00011 Moscow ZARUBEZHNOYE VOYENNOYE OBOZRENIYE in Russian No 8, Aug 89 (signed to press 23 Aug 89) pp 45-52

[Article by Capt 1st Rank Yu. Pelevin and Capt 2d Rank V. Surnin]

[Text] As one kind of antisubmarine weapon, the mine always has been rather reliable for creating a stable defense in friendly waters as well as for blockading enemy bases, ports and straits.

Mines saw considerable development as an ASW weapon after World War II. The creation of deep-water mines fitted with submarine detection devices, IFF classifiers, and remote arming systems as well as integration with torpedo ordnance permitted considerably expanding the areas of mine weapon employment, acting selectively only against enemy ships, and laying mines in peacetime to be armed on command.

The foreign press notes that use of mines against submarines makes it possible to accomplish the following missions: preventing submarines from putting to sea by blockading naval bases and basing facilities, destroying submarines during their operational deployment through strait zones and ASW barriers, restricting freedom of maneuver in a combat zone, and reducing the combat effectiveness of submarine crews by the psychological effect of the threat of exploding a mine.

Despite the great diversity of mines, they have basically the same design. A mine consists of a body, explosive charge, fuze, special devices and power sources (Fig. 1).

The mine body is a sealed case made of steel, aluminum, glass reinforced plastic or plastic. Mines with bodies

Fig. 1. Basic design of British Sea Urchin mine

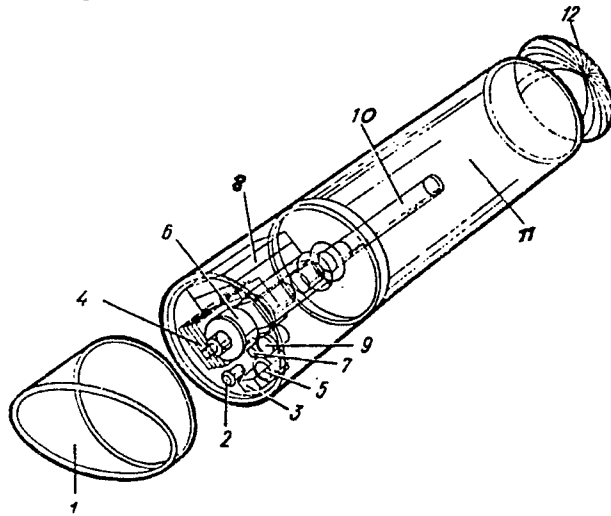

Key:

1. Nose cap
2. Switching unit
3. Magnetometer
4. Electronics unit
5. Hydrodynamic sensor
6. Safety and actuating mechanism
7. Hydrostatic sensor
8. Power source
9. Acoustic sensor
10. Primer
11. Explosive charge
12. Tail cone

made of low-magnetic materials to reduce the probability of detection by magnetic anomaly detectors have become most widespread in recent years.

According to western press data, high-explosives such as TNT, particularly torpex with a TNT equivalent of 1.2-1.6 tons, are being used for mine charges. Development of explosives with a TNT equivalent of 5-10 tons has been announced. In addition, mine designs with shaped-charge effect have been developed which foreign military specialists believe substantially increases their destructive force.

According to the nature of the charge, mines can be nuclear or filled with conventional explosives.

According to principle of operation, mine fuzes are divided into contact (reacting to direct contact with a submarine) and influence (reacting to a submarine's physical fields).

Combination influence fuzes reacting to a submarine's acoustic, magnetic, hydrodynamic and other fields have become most widespread in modern foreign mines. A mine has special devices: safety devices (providing safety in handling the mine), delay devices (shifting the mine from a safe to an armed condition and vice versa at the

expiration of a set time period), counter devices (providing for the mine's detonation after a given number of blank triggerings from a submarine's physical fields), command arming switches, and sterilizers (destroying mines if necessary). Mines are divided into seabed, moored and floating mines depending on the methods by which they maintain the place where they are laid.

Seabed mines are laid on the seabed and are equipped with combination influence fuzes. They are difficult to detect and destroy. The absence of an anchor in these mines and of devices for automatic placement at a given depth considerably simplifies their design and makes them more compact.

Modern seabed mines intended for ASW are laid in areas with sea depths over 50 m, but no deeper than the limit established by the mine body's strength. The basic types of foreign seabed mines used for destroying submarines include the U.S. Mk 52 Mod 2, Mk 55 Mod 2 and Mk 62 through 65 of the Quickstrike family; the UK Sea Urchin and Stonefish; the French MCC 23 (Fig. 2 [figure not reproduced]); and the Italian VS SM600 and MR-80 (Fig. 3 [figure not reproduced]). All these mines have fuzes of different types reacting to such submarine physical fields as magnetic, hydrodynamic and acoustic.

Moored mines, which in contrast to seabed mines can be laid at greater depth, are the most widespread in ASW in the navies of foreign states. They use both contact and influence fuzes.

Antenna mines are a variety of moored mines. Such a mine detonates either when its antenna touches a submarine or when there is direct contact. The upper and lower antennas are about 30 m long. The upper antenna is held in a vertical position by a special float.

Western specialists include the U.S. Mk 60 Captor, Mk 56 and Mk 57; the French H-30; and the West German UMC among the main types of moored mines.

Floating mines differ from moored and seabed mines in that they freely displace under water at a given depth. Use of such mines is extremely limited, since indefiniteness of location makes floating mines dangerous both for enemy submarines and for friendly ships.

Foreign specialists believe that one of the most important directions in the development of mine weapons is the integration of mine and torpedo ordnance as reflected in the appearance of combination mines, which include components (technical devices) previously used only in torpedoes and rocket torpedoes. Mobile mines, of which the Mk 67 SLMM can serve as an example (Fig. 4 [figure not reproduced]), are typical in this respect. The Mk 67 was developed on the basis of obsolete modifications of the Mk 37 antisubmarine electric torpedo, which additionally included certain mine devices and a combination influence fuze.

In the opinion of foreign specialists, the Mk 60 Captor deep-water mine holds a special place among various types of mine weapons. It is a combination torpedo and mine device. It has the greatest killing zone of all mines in the U.S. Navy arsenal and can be used at depths to 800 m. The service life of the Mk 60 Captor is from 2 to 5 years. In contrast to previous antisubmarine mines with contact and influence fuzes triggered when the submarine passes in their immediate proximity, this mine's gear is capable of detecting a submarine at distances to 1,000-1,500 m and classifying her by the IFF principle. After this the torpedo is released, makes an all-around search, and pursues and engages the target.

The principal components of the Mk 60 Captor mine are the container with torpedo and launch system, anchor arrangement with a system for automatic container placement at a given depth, and influence gear of the automatic target detection and classification system.

A combination of hydrostats which are part of this mine and which are adjusted for various hydrostatic pressures ensures placement of the container with torpedo at a given depth, which depends on the depth of the location. With a sea depth to 230 m the container is placed in a near-bottom position (7.5 m from the bottom). In areas with depths of 230-460 m the container depth equals half

the location depth, and from 460 m to the permissible depth of 800 m it will be near maximum depth—305 m.

The target search and classification gear detects a target, determines the direction and distance to it with subsequent classification, and supports launch of the torpedo from the container to the submarine's location. IFF classification occurs in the Mk 60 Captor's gear by the emission of coded acoustic signals in the direction of a detected target and reception of answering signals automatically re-radiated by a friendly submarine equipped with special gear. In case an "enemy" submarine is detected, signals reflected from the submarine hull will return to the mine's logic device with parameters not corresponding to the code. Then the logic device will determine distance to the submarine and will give the command for filling the container with water, opening its cover and launching the torpedo.

According to foreign specialists, the Mk 60 Captor mine is being upgraded in the direction of improving sensitivity of the Mk 46 Mod 4 torpedo guidance system, reducing its noise, improving the mine's mechanics and body to bring the container's maximum submersion to 800 m, increasing the reaction radius, and improving the selectivity and antijam capability of the automatic target detection and classification system gear.

Specifications and performance characteristics of antisubmarine mines are given in the table.

Specifications and Performance Characteristics of Antisubmarine Mines

Type of Mine (Country)	Weight, kg: Overall/Explosives	Maximum Placement Depth, m	Platforms
Seabed			
Mk 52 Mod 2 (USA)	567/270	183	Aircraft, surface combatants, submarines
Mk 55 Mod 7 (USA)	995/576	183	Same as above
Quickstrike family (USA):			
Mk 62	227/87	100	Same as above
Mk 63	454/202	100	Same as above
Mk 64	908/.	100	Same as above
Mk 65	908/.	100	Same as above
Mk 67 SLMM (USA)	1,000/300	100	Submarines
Sea Urchin (UK)	754/250	90	Aircraft, surface combatants, submarines
Stonefish (UK)	990/600	200	Same as above
MCC 23 (France)	845/530	150	Submarines
G-1 (FRG)	771/535	60	Surface combatants
TNA (FRG)	900/500	200	Aircraft, submarines
VS SM600 (Italy)	780/600	150	Aircraft, submarines, surface combatants
MR-80 (Italy)	800/500	300	Submarines, surface combatants
Manta ¹ (Italy)	220/140	100	Surface combatants
MAE-10 (Spain)	830/530	100	Aircraft, submarines, surface combatants
ROCKAN ¹ (Sweden)	180/120	100	Surface combatants

Specifications and Performance Characteristics of Antisubmarine Mines (Continued)

Type of Mine (Country)	Weight, kg: Overall/Explosives	Maximum Placement Depth, m	Platforms
Moored			
Mk 56 (USA)	1,010/500	360	Surface combatants
Mk 57 (USA)	934/154	360	Submarines
Mk 60 Captor (USA)	950/44	Over 800	Aircraft, submarines, surface combatants
UMC (FRG)	900/200	500	Aircraft, submarines
H-30 (France)	820/300	500	Submarines, surface combatants
74 (Sweden)	205/.	110	Surface combatants
77 (Sweden)	470/.	200	Surface combatants

1. General view of mines shown in Figs. 10 and 11 [figures not reproduced].

One trend in the development of antisubmarine mine weapons, according to foreign press announcements, is use of a modular principle of building certain models of mines. The program for creating such mines (the Mk 62, Mk 63, Mk 64 and Mk 65 Quickstrike family) consists of developing a standardized set of components which permit refitting series-produced aerial bombs (such as Mk 82 and Mk 84) as mines with combination influence fuzes of the most modern type. The advantages of this approach are the reduced cost of developing and creating the mine; broad opportunities for modernization; and simplification of preparing, suspending on carriers, and laying using standard airfield equipment.

One direction in the development of mine weapons in foreign navies is creation of a remote arming system. After the minefield is laid its status—dangerous or safe—is set by coded command signals transmitted via sonar emitters from a control center which can be located, for example, aboard a submarine.

This idea is very complicated to realize, since it essentially requires 100-percent reliability in the functioning of all components of the remote mine weapon control system.

Western military specialists note that mine weapons subsequently will be upgraded along the directions of an improvement in mine survivability (normal functioning time after being laid) and resistance to sweeping, an increase in the mine's destructive effect on a target, and an expansion in possible minelaying areas.

The power source is the principal factor determining a mine's reliability. As a rule it is a lithium battery at the present time, but in the future it is expected that new types of sources—radio isotope and thermo-electric with a service life up to ten years—may be used.

The problem of improving mines' resistance to sweeping lies above all in decreasing their revealing signs (reflectivity, magnetic field level and so on).

A mine's destructive effect depends above all on parameters of the explosive charge. Equipping mines with nuclear charges is being considered as one of the ways to increase mines' destructive effect. According to foreign

press data, the United States already has created such models with nuclear charges, but foreign military specialists believe that series production of such mines is inadvisable, since each of them engages only one submarine and consequently has almost no advantage over a mine with a conventional charge.

Western specialists believe an expansion in minelaying areas is possible by creating mines of two types—deep-water and shallow. The problem of creating deep-water mines, usually moored mines, is considered especially complex. Their weak component is the mooring cable. Much emphasis is being placed on improving its characteristics, and in particular increasing its survivability.

Methods of laying and combat employment of mine weapons. Aviation, surface combatants and submarines as well as vessels of civilian departments (ferries, commercial vessels, fishing vessels and other craft) can be used for minelaying.

Foreign specialists believe the use of aviation to be the most effective in creating antisubmarine minefields, since it lays them in compressed time periods regardless of time of day and weather conditions. At the same time, aviation also has a serious drawback—low minelaying accuracy.

Minelaying is accomplished most simply from surface combatants and vessels. Mines are fastened on guide rails one after the other and when being laid are shoved along the rails over the side (Fig. 5 [figure not reproduced]).

Surface combatants have a large mine-carrying capacity and can accomplish minelaying with higher accuracy. Among their deficiencies are low concealment of operation and the need for operational cover and for organization of reliable navigation support.

Moored mines can be placed in the initial position by two methods—by rising toward the surface from the bottom and by being laid from the water's surface. In case moored mines which rise up from the bottom are used (Fig. 6), the drum with the mooring cable is integral with the body. The mine is fastened to the anchor by steel straps which prevent it from separating from the anchor. One end of a strap is permanently fastened to the anchor and the other end is passed through special lugs

(eyebolts) in the mine body and connected to a disconnecter in the anchor. When the mine falls into the water when being laid, it heads for the bottom together with the anchor. After 10-15 minutes the disconnecter dissolves in the sea water, frees the straps and the mine begins to surface. When it is at a preset depth (h) a hydrostatic device situated near the drum stops the mooring cable. A clockwork mechanism can be used in place of a water-soluble disconnecter.

Fig. 6. Method of laying moored mines by rising up from the bottom

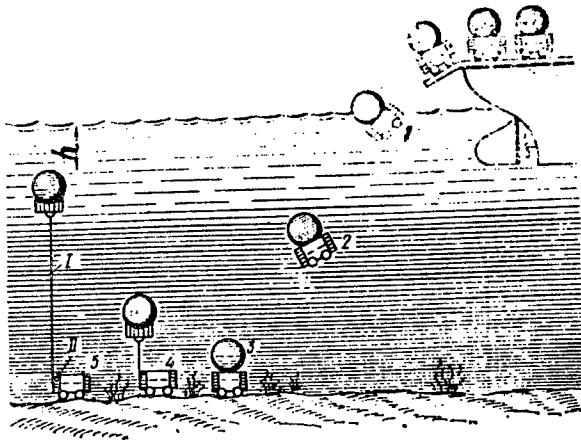

Key:

1. Mine released
2. Mine submerges
3. Mine on bottom
4. Mine cable unwinds, mine rises
5. Mine set at given depth h
- I. Mooring cable
- II. Mine anchor

Moored mines are laid from the water's surface (Fig. 7) in the following manner. A drum with mooring cable wound on it is accommodated on the mine anchor. A special stopping mechanism connected with a weight by means of a lanyard or cord is fastened to the drum. When the mine is released overboard it remains on the water's surface, having reserve buoyancy, but the anchor separates and sinks, unwinding the mooring cable from the cable drum. The weight fastened to the lanyard, the length of which equals the desired mine immersion depth (h), moves ahead of the anchor. The weight touches bottom first and thereby puts a certain slack in the lanyard, at which point the stopping mechanism triggers and the mooring cable stops unwinding. The anchor continues moving to the bottom, drawing along the mine, which submerges to a depth equal to the lanyard's length.

Submarines are used actively for minelaying. Foreign specialists note a number of advantages of this method: the concealment and the possibility of conducting final reconnaissance and laying mines on movement routes of the opposing side's submarines.

Fig. 7. Surface method of minelaying

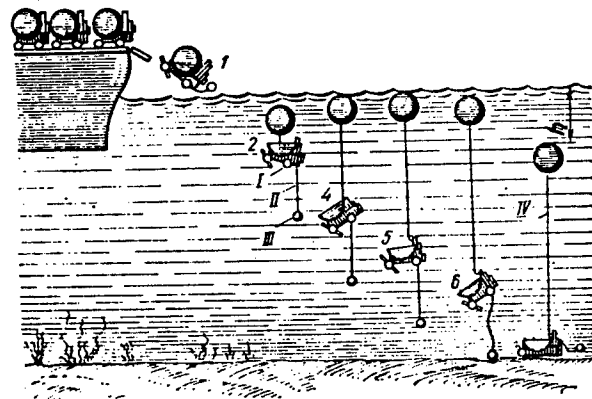

Key:

1. Mine released
2. Mine has separated from anchor, mooring cable freely unwinds from cable drum
4. Mine at surface, mooring cable continues to unwind
5. Mine at surface, mooring cable continues to unwind
6. Weight has reached bottom and mooring cable has stopped unwinding, anchor draws mine downward and places it at given depth (h) equal to lanyard length
- I. Mine anchor
- II. Lanyard
- III. Weight
- IV. Mooring cable

Mines are laid from submarines through the torpedo tubes. In addition, the FRG has created a special MWA-09 mounted device for submarines to transport and lay mines in a submerged condition at a speed up to 12 knots (up to 24 mines with a maximum length of 3.1 m and a diameter of 0.54 m). Two containers of 12 mines each are fastened to the sides in the forward part of the submarine. Moored mines can be laid by the methods described above. Mobile mines are laid from submarines in the following manner. The submarine arrives at the designated place and fires the mines from the torpedo tubes. The mobile mine (such as the U.S. Mk 67 SLMM) turns on its motor after emerging from the torpedo tube and displaces independently along a programmed route to the placement point at a distance of up to 20 km. The mine is armed after arrival at the designated point. Thus such a mine can be laid covertly in guarded water areas of harbors, ports and roadsteads, and in channels.

Aircraft-laid mines (usually seabed mines) are adapted for suspension to an aircraft and are supplied with a parachute. They have a cylindrical shape with a tapered nose, which during flight in the air is usually covered by a fairing which separates from the mine on contacting the water. The tapered end ensures that the mine rotates to a horizontal position after entering the water, which permits lowering the minimum limit of its placement depth. The flight of mines dropped from altitudes of 230-600 m is stabilized using decelerating stabilizers or

Fig. 9. Schemes for employing mines

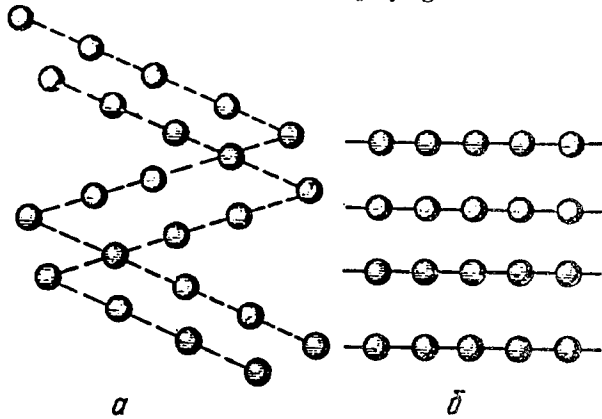

Key:
a. Zigzag
b. Cluster

parachutes. The U.S. Navy has developed the CAML (Cargo Aircraft Minelayer System) program with the objective of expanding the makeup of forces for aircraft-laying of antisubmarine mines. This system provides for use of military transport aircraft for minelaying (Fig. 8 [figure not reproduced]).

According to foreign press data, ASW mines are laid in lines of one, two or three rows both vertically and horizontally (Fig. 9) depending on the tactical situation. In this case mines in adjacent rows are staggered. Two schemes of the mines' combat employment are widespread: in a zigzag (of two or more rows, see Fig. 9a) and in clusters (a small number of mines laid in several rows, see Fig. 9b).

The Mk 60 Captor deep-water mines are laid in a single line at a distance from each other that usually exceeds the reaction radius of the mine's active channel. The second line is at a distance from the first line exceeding the range of the Mk 46 torpedo. After safety devices are triggered the Mk 60 Captor mine is armed and an automatic target detection and classification system begins functioning. On detecting a target and determining that it belongs to the "enemy" submarine category, the logic device issues a command to launch the torpedo, which makes a final search for the submarine along one of the given variants of a programmed search path.

In the assessment of foreign specialists, an improvement in methods of combat employment and an increase in combat capabilities of antisubmarine mines will substantially improve the effectiveness of ASW.

COPYRIGHT: "Zarubezhnoye voyennoye obozreniye", 1989.

U.S. Navy Future Missile Cruiser Project

904Q0001J Moscow ZARUBEZHNOYE VOYENNOYE OBOZRENIYE in Russian No 8, Aug 89 (signed to press 23 Aug 89) pp 52-54

[Article by Capt 2d Rank B. Poyarkov, candidate of military sciences]

[Text] The foreign press notes that trends toward a reduction in radar signature and an increase in firepower of weapon platforms can significantly revolutionize methods of naval warfare in the approaching century.

In late 1986 the U.S. Navy command came out with another concept, "Revolution at Sea," within the framework of the new U.S. "naval strategy."¹ This concept proposes realization of a number of ultramodern ship-building projects, including the "Strike Cruiser-2000" being handled by research group Mike² under the naval staff. Its fundamental ideas are based on new principles and approaches in the sphere of combat employment of missile weapons. The most important of them are worded as follows: "Maximize ordnance on target," "Integrated ship task force," "Relay guidance of missiles" and "Weapon battle space."

The first principle means that everything on a missile ship or group of such platforms, from their design to the makeup of the crew and their living conditions, must be subordinated to the primary mission: launching the optimum or maximum possible number of missiles against enemy targets.

The second principle formulates a trend taking shape at the present time toward integration of onboard weapons, combat assets, and equipment and facilities into a unified system not only on an individual ship, but also in a ship group or force.

"Relay guidance" of weapons—use of various methods of guiding missiles after their launch—also can be achieved in realizing the first principles. In this case certain force platforms (ships, aircraft or helicopters) will detect and issue target designations, others will launch missile weapons, and still others will perform guidance. In addition, other combinations also are possible.

Group Mike specialists assume that shipboard weapons will be employed within limits of the "battle space" with the following parameters: altitude range 24 km, range of fire 550-2,100 km, water depth to 500 m. In their assessment, the principal components of combat assets at the turn of the century will be AN/SPY-1 phased array radars of various modifications of the multifunction Aegis weapon system, cruise and other missiles for various purposes, as well as general-purpose vertical missile launchers. Studies conducted by U.S. specialists simulating combat operations off the shores of the USSR using different options for initiating hostilities and various scenarios developed on the basis of the new U.S. naval strategy showed that the most serious problem

under present conditions is the insufficient number of missiles on hand on ships. In addition to achieving a number of other objectives, the "Strike Cruiser-2000" project also can ensure overcoming this shortcoming.

According to its developers' concept, the most important features of the future ship should be very low radar and thermal signature (through smoothed lines and faired surfaces, the absence of any superstructures, and low profile with simultaneous retention of good seaworthiness); long range combined with considerable power plant economy; and broad versatility of combat employment (including the capability of performing specific missions during a troop landing).

One basic component of the future missile cruiser is a large capacity general-purpose vertical launcher (for 270-274 missiles). It can be configured from standard modules similar to those used in "Ticonderoga"-Class missile cruiser launchers. The upper part of the vertical launcher is protected by an armor plate in which hatches have been made (closed by covers) for loading or unloading launch canisters with missiles, as well as openings for releasing exhaust gases during launch. An important feature of such a launcher is the possibility of launching several missiles simultaneously. The vertical launcher can be loaded with Tomahawk cruise missiles (in the antiship version and for firing against ground targets), Standard long-range and medium-range surface-to-air missiles, future Quadpack short-range surface-to-air missiles being developed by Martin Marietta (up to four missiles in one container cell), as well as new vertical-launch ASROC ASW missiles (ASROC-VLS). Loading variants can change depending on missions assigned the ship.

The bridge on the ship has a secondary purpose, basically for visual observation of the situation when maneuvering in narrows, during underway replenishment, and when anchoring or mooring. It is assumed that there will be four persons on the bridge who support ship maneuvering using remote controls and TV video monitors.

The combat information center is located beneath the bridge. It has large tactical situation display screens; a central console concentrating equipment and controls for the power plant, ship's generator unit, and remote steering; consoles for radio communications transceiver gear; navigation monitors; and radar and sonar indicator devices and display equipment. All information coming to the combat information center is displayed on the screens of different displays, video monitors and other indicator equipment of the automated combat control system's multifunction operator consoles. Navigation calculations can be performed on computers based on NAVSTAR satellite radionavigation system data in real time. A drone outfitted with television infrared gear in combination with a laser rangefinder can become an important shipboard means of receiving over-the-horizon target designation data.

The bridge and combat information center, supplied with means of protection against electromagnetic pulse, are accommodated in armored modules which protect against fragments and explosions of small munitions as well as against damage and casualty factors of mass destruction weapons.

Different options are being considered for the hull of the future cruiser. The possibility of using the hull of "Arleigh Burke"-Class ships is not precluded in case of budgetary restrictions.

Foreign specialists believe that the future ship's main power plant may be a Rankine cycle gas turbine with exhaust-heat boiler. It is proposed to accommodate it immediately beneath the upper deck and remove exhaust gases directly overboard beneath the water, which will rid the ship's design of some of the elements of strong thermal radiation as well as radar signature. For comparison it can be said that other types of modern gas-turbine plants usually are in the lower part of the ship and the system for removing gases from them is very complicated and cumbersome (as a rule, it occupies up to 20 percent of the volume of the entire hull). The temperature of exhausted gases in a Rankine cycle turbine is greatly reduced because of recirculation, which contributes to a decrease in the ship's thermal signature.

According to estimates by Group Mike specialists, the efficiency of the Rankine cycle gas-turbine plant with exhaust-heat boiler is 30 percent higher than for traditional plants. This leads to an increase in range or, with range remaining the same, to a decrease in fuel stores on ships by approximately one-third. Despite all the attractiveness of this type of power plant, however, Group specialists are studying the possibility of also using the superconductivity effect in power plants.

The foreign press notes that the new ship project fully embodies the idea of modular configuration of the design. Points of support (reinforced construction components) will be provided in the hull where modules of standard size and different functional purpose can be accommodated, such as additional fuel storage modules, crew's accommodation modules that are easily replaceable by ship weapon system modules, living space modules for landing subunits, and modules for storing their combat equipment. Such an approach to solving design problems can, according to the developers' concept, lead to the appearance of an entire family of new general-purpose ships based on one hull that are capable of performing different combat missions.

The appearance of the "Strike Cruiser-2000" project attests to the U.S. Navy leadership's intentions of striving in the future as well for qualitative superiority at sea, including for the surface fleet.

Footnotes

1. For more detail about it see ZARUBEZHNOYE VOYENNOYE OBOZRENIYE, No 11, 1986, pp 49-53—Ed.

2. It was named from the first letter of the last name of Admiral Metcalf, director and chief ideologue of the project under development.

Basic Specifications and Performance Characteristics of Torpedoes of Navies of Capitalist Countries

904Q0001K Moscow ZARUBEZHNOYE
VOYENNOYE OBOZRENIYE in Russian
No 8, Aug 89 (signed to press 23 Aug 89) pp 55-60

COPYRIGHT: "Zarubezhnoye voyennoye obozreniye",
1989.

[Reference data by Capt 1st Rank Yu. Yurin]

[Text]

Type Torpedo (Year Operational)	Caliber, mm/Length, m	Weight, kg: Overall/Explosives	Speed, knots/ Range, km	Maximum Running Depth, m	Guidance System	Purpose	Platforms
United States							
Mk 14 Mod 3 (1941)	533/6.25	1450/270	46/5.8; 32/10.2	18	-	Antiship	Submarine
Mk 15 Mod 3 (1943)	533/7.3	1740/360	45/5.5; 33.5/9.1	18	-	Antiship	Surface combatant
Mk 16 (After 1945)	533/6.25	2180/400	45/20	.	-	Antiship	Submarine
Mk 18 (1945)	533/6.25	1500/270	29/3.65	6-18	-	Antiship	Submarine
Mk 27 Mod 4 (.)	482/3.18	470/.	./.	.	Acoustic passive homing system	Antiship	Submarine, surface combatant
Mk 32 Mod 2 (After 1945)	482/2.1	350/50	12-20/8	6	Acoustic active homing system	Antiship	Surface combatant, aircraft
Mk 35 (.)	533/4.11	720/.	./.	.	Acoustic homing system	Antiship	Surface combatant
Mk 37 Mods 0 & 3 (1957, .)	482/3.52	645/150	30/7	370	Acoustic active-passive homing system	Antisubmarine	Submarine
Mk 37 Mods 1 & 2 (1961, .)	482/4.09	766/150	24/20	370	Remotely controlled by wire, acoustic active-passive homing system	Antiship	Submarine
NT37C or Mk 37C (1975)	482/4.09	766/150	33/15	300	Remotely controlled by wire, acoustic active-passive homing system	Dual purpose	Submarine, surface combatant
NT37D Mod 1 (1980)	482/4.5	750/150	./.	.	Remotely controlled by wire, acoustic active-passive homing system	Dual purpose	Submarine, surface combatant
NT37E Mod 3 (1985)	482/3.85	642/150	./.	.	Remotely controlled by wire, acoustic active-passive homing system	Dual purpose	Submarine, surface combatant
NT37D Mods 2 & 3 (1980)	482/3.85	642/150	.	.	Remotely controlled by wire, acoustic active-passive homing system (less remote control for Mod 3)	Dual purpose	Submarine, surface combatant
NT37E Mod 2 (.)	482/4.5	750/150	42/14	.	Acoustic active-passive homing system	Dual purpose	Submarine, surface combatant
Mk 39 (1950)	533/.	./.	50/9-10	.	Remotely controlled by wire	Dual purpose	Submarine, surface combatant

Type Torpedo (Year Operational)	Caliber, mm/Length, m	Weight, kg: Overall/Ex- plosives	Speed, knots/ Range, km	Maximum Running Depth, m	Guidance System	Purpose	Platforms
Mk 43 Mods 1 & 3 (1954-1957)	254/2.36	137/30	20/4.5	300	Acoustic active homing system	Antisubmarine	Surface com- batant, aircraft, helicopter
Mk 44 Mod 1 (1960)	324/2.56	233/34	30/5.5	300	Acoustic passive homing system	Antisubmarine	Surface com- batant, aircraft, helicopter, ASW missile
Mk 45 Astor Mods 0 & 1 (1960-1964)	482/5.76; 6.1	1310/Nu- clear (10-30 KT)	40/11; 16	200	Remotely con- trolled by wire	Antisubmarine	Submarine
Mk 45F Freedom Mods 0 & 1 (1972 & 1975)	482/5.72	1240/295	40/14	15	Remotely con- trolled by wire or remotely con- trolled by wire and homing on wake	Antiship	Submarine, sur- face combatant
Mk 46 Mod 0 (1964)	324/2.67	258/44	45/9	450	Acoustic active- passive homing system	Antisubmarine	Surface com- batant, aircraft, helicopter, ASW missile, mine
Mk 46 Mod 1 (1967)	324/2.59	230/44	45/9-11	450	Acoustic active- passive homing system	Antisubmarine	Surface com- batant, aircraft, helicopter, ASW missile
Mk 46 Mod 2 (1972)	324/2.59	230/44	45/10-11	450	Improved active-passive homing system	Antisubmarine	Surface com- batant, aircraft, helicopter, ASW missile
Mk 46 Mod 4 (1976)	324/2.6	270/44	35-40/7.5	.	Improved active-passive homing system	Antisubmarine	Captor mine
Mk 46 Mod 5 (1979)	324/2.6	233/45	45/Up to 15	600	Improved active-passive homing system	Antisubmarine	Surface com- batant, aircraft, helicopter, ASW missile
Mk 48 Mod 1 (1972)	533/5.8	1600/120	50/46	600	Remotely con- trolled by wire, acoustic active- passive homing system	Dual purpose	Submarine
Mk 48 Mod 3 (1975)	533/6.2	1580/267	50-55/46	600	Remotely con- trolled by wire, acoustic active- passive homing system	Dual purpose	Submarine
Mk 48 Mod 4 (1981)	533/5.8	1600/.	55/38	914	Remotely con- trolled by wire, acoustic active- passive homing system	Dual purpose	Submarine
Mk 48 Mod 5 ADCAP (1988)	533/5.8	1600/.	50-55/46	914	Remotely con- trolled by wire, acoustic active- passive homing system	Dual purpose	Submarine
Mk 50 (.)	324/2.8	400/45	55/.	600	Acoustic active- passive homing system	Antisubmarine	Surface com- batant, aircraft, helicopter, ASW missile
Great Britain							
Mk 4 (.)	533/.	1410/	40/4.5	.	-	.	Submarine

Type Torpedo (Year Operational)	Caliber, mm/Length, m	Weight, kg: Overall/Ex- plosives	Speed, knots/ Range, km	Maximum Running Depth, m	Guidance System	Purpose	Platforms
Mk 8 (1930's)	533/6.7	1535/300	45/4.5	16	-	Antiship	Submarine, sur- face combatant
Mk 20 (1957, modernized in 1971)	533/4.11	821/91	20/11	240	Acoustic passive homing system	Antisubmarine	Submarine
Mk 24 Tigerfish Mod 0 (1973)	533/6.46	1550/.	.14	350	Remotely con- trolled by wire, acoustic active- passive homing system	Antisubmarine	Submarine
Mk 24 Tigerfish Mod 1 (1979)	533/6.46	1550/134	35/13; 24/29	5-450	Remotely con- trolled by wire, acoustic active- passive homing system	Dual purpose	Submarine
Mk 24 Tigerfish Mod 2 (1985)	533/6.46	1550/.	./.	.	Remotely con- trolled by wire, improved acoustic active- passive homing system	Dual purpose	Submarine
Stingray (1983)	324/2.6	1850/300	40-45/7.5	Around 700	Acoustic active- passive homing system	Antisubmarine	Surface com- batant, aircraft, helicopter
Spearfish (1987)	533/6.0	260/45	55 & 70/Up to 40	900	Remotely con- trolled by wire, acoustic active- passive homing system	Dual purpose	Submarine

France

L3 (1963)	550/4.3	900/200	25/5.5	300	Acoustic active homing system	Antisubmarine	Submarine, sur- face combatant
L4 (1964)	533/3.13	540/100	30/5	.	Acoustic active homing system	Antisubmarine	Aircraft, ASW missile
L5 Mod 1 (1973)	533/.	1000/.	35/.	.	Acoustic active- passive homing system	Dual purpose	Surface com- batant
L5 Mod 3 (1973)	533/.	1300/.	35/.	.	Acoustic active- passive homing system	Dual purpose	Submarine
L5 Mod 4 (1974)	533/.	./.	35/.	.	Acoustic active- passive homing system	Antisubmarine	Submarine
L5 Mod 4P (1977)	533/4.4	920/150	35/7	.	Acoustic active- passive homing system	Dual purpose	Submarine
E14 Mod 1 (1962)	550/4.29	900/200	25/5.5	6-18/.	Acoustic active homing system	Antiship	Submarine
E-15 (1960's)	550/6.0	1350/300	25/12	6-18	Acoustic active homing system	Antiship	Submarine
Z16 (1960's)	550/7.2	1700/300	30/10	6-18	Controller	Antiship	Submarine
F17 Mod 2, or export version F17P (1977)	533/6.0	1300/250	40/18	600	Remotely con- trolled by wire, acoustic active- passive homing system	Dual purpose	Submarine
Murene (1992)	324/2.9	280-295/50	38 & 50/Up to 10	1000	Acoustic active- passive homing system	Antisubmarine	Surface com- batant, aircraft, helicopter, ASW missile

Type Torpedo (Year Operational)	Caliber, mm/Length, m	Weight, kg: Overall/Ex- plosives	Speed, knots/ Range, km	Maximum Running Depth, m	Guidance System	Purpose	Platforms
------------------------------------	-----------------------------	--	----------------------------	--------------------------------	--------------------	---------	-----------

FRG

G7A (Up to 1945)	533/7.0	1510/300	44/6.6	16	-	Antiship	Submarine, surface combatant
G7E (Up to 1945)	533/7.2	1600/300	30/5	16	-	Antiship	Submarine
Seal DM2A1 (1975)	533/6.08 (6.55)	1370/260	35/13; 23/28	4-18	Remotely controlled by wire, acoustic active-passive homing system	Antiship	Submarine, missile craft, motor torpedo boat
SST 4 (1975)	533/5.93	1370/260	./.	100	Remotely controlled by wire, acoustic active-passive homing system	Dual purpose	Submarine, missile craft, motor torpedo boat
Seeheld DM2A3 (1976)	533/6.7	.260	./.	300	Remotely controlled by wire, acoustic active-passive homing system	Dual purpose	Submarine, surface combatant
Seeschlange (1975)	533/4.15 (4.62)	.90	30/10	300	Remotely controlled by wire, acoustic active-passive homing system	Antisubmarine	Submarine

Italy

G 62ef Kangaroo (1960's)	533/6.2	1130/.	27/7	.	Remotely controlled by wire	Antisubmarine	Submarine
A 184 Mod 1 (1975)	533/6.0	1265/200	36/10; 24/25	.	Remotely controlled by wire, acoustic active-passive homing system	Dual purpose	Submarine, surface combatant
A 244 (1976)	324/2.7	220/40	Up to 33/6	Around 450	Acoustic active-passive homing system	Antisubmarine	Surface combatant, aircraft, helicopter
A 244/S (1984)	324/2.75	235/34	30/6	.	Same as above	Antisubmarine	Surface combatant, aircraft, helicopter, ASW missile
A 290 (1993)	324/.	./.	Up to 50/.
U-6 (1955)	515/.	1000/.	./.	.	Acoustic homing system	Antisubmarine	.

Sweden

Type 41 (1970's)	440/2.44	250/.	./.	.	Acoustic active homing system	Dual purpose	Submarine, surface combatant
Type 42, or TP 42 (1975)	400/2.44	250/.	./.	.	Remotely controlled by wire, acoustic active-passive homing system	Dual purpose	Submarine, surface combatant, helicopter
Type 42 Mod TP 421 & 422 (1975)	400/2.44	250/.	./.	.	Acoustic passive homing system	Dual purpose	Submarine, surface combatant, helicopter
Type 42 Mod TP 427 (1976)	400/2.44	298/50	25/10; .20	.	Remotely controlled by wire, acoustic passive homing system	Dual purpose	Submarine, surface combatant, helicopter

Type Torpedo (Year Operational)	Caliber, mm/Length, m	Weight, kg: Overall/Explosives	Speed, knots/Range, km	Maximum Running Depth, m	Guidance System	Purpose	Platforms
Type 43 Mod TP 431 (1986)	400/2.64	310/50	.Up to 30	200	Acoustic passive homing system	.	Submarine, surface combatant, helicopter
Type 43 Mod TP 43XO (1986)	400/2.64	310/50	.Up to 30	.	Remotely controlled by wire, acoustic passive homing system	Dual purpose	Submarine, surface combatant, helicopter
Type 43 Mod TP 437	400/2.64	310/50	.Up to 30	.	Acoustic passive homing system	.	.
Type 61 or TP 61 (.)	533/7.03	1765/250	./.	./.	Remotely controlled by wire	Antiship	Surface combatant, aircraft, helicopter
Type 61 Mod TP 613 (1972)	533/7.03	1765/367	34/18	2-12	Remotely controlled by wire	Antiship	Submarine, surface combatant
Type 61 Mod TP 617 (.)	533/6.9	1860/250	60/30	.	Remotely controlled by wire, homing	Antiship	Submarine, surface combatant

Japan

Type 54 Mod 1 (1954)	533/7.5	1570/.	./22	.	-	Antiship	Submarine, surface combatant, motor patrol boat
Type 54 Mod 2 (1954)	533/7.5	./.	./Up to 30	.	Acoustic passive homing system	Antiship	Submarine, surface combatant, motor patrol boat
Type 54 Mod 3 (1954)	533/7.5	./.	./Up to 30	.	Acoustic passive homing system	Dual purpose	Submarine, surface combatant, motor patrol boat
Type 54 Mod 3A (1956)	533/7.5	1600/.	./Up to 30	.	Acoustic passive homing system	Dual purpose	Submarine, surface combatant, motor patrol boat
Type 72 G-5 & -5B (1972)	533/6.25	1685/Up to 300	60/15; 45/25	1-200	.	Dual purpose	Submarine, surface combatant, motor patrol boat
Type 73 G-9 & -9B (1973)	324/.	./.	Around 40/Up to 6	.	Acoustic active homing system	Antisubmarine	Submarine, surface combatant, aircraft, helicopter, ASW missile
Type 80 G-11, or G-RX1 (1980)	483/3.5	Around 650/.	30/.	.	Remotely controlled by wire, acoustic active-passive homing system	Dual purpose	Submarine
Type 88 G-RX2 (1988)	533/7.5	1600/.	50/.	.	Remotely controlled by wire, acoustic active-passive homing system	Dual purpose	Submarine
G-RX4 (1990's)	324/.	./.	./.	./.	.	Antisubmarine	Surface combatant, aircraft, helicopter

MILITARY ECONOMICS, INFRASTRUCTURE

Greece's Military Industry

904Q0001L Moscow ZARUBEZHNOYE
VOYENNOYE OBOZRENIYE in Russian
No 8, Aug 89 (signed to press 23 Aug 89) pp 61-68

[Article by Maj V. Surkov]

[Text] The strengthened influence of military-industrial complexes on the domestic and foreign policy of imperialist states in recent years as well as the course they are following toward escalating the arms race inevitably also affect less developed capitalist countries previously not involved in this process.

Being a member of the NATO bloc, Greece is forced to give in to the general demands of this organization's leadership for increasing military expenditures and strengthening militaristic preparations despite financial difficulties. Although the government does have certain differences with the U.S. and NATO leadership, Greece's ruling circles on the whole follow a course toward continuing military cooperation within the bloc's framework and building up the might of their Armed Forces.

This course is reflected in a constant growth of financial assets being directed toward military purposes. The Greek Ministry of Defense budget presently is being drawn up based on a long-range program of "developing and improving the Armed Forces" adopted by the Defense Council in October 1988. It is figured for 1989-1993 and its realization will cost taxpayers up to 350 billion drachmas (\$2.4 billion). Greece holds one of the first places among NATO countries in the share of overall military expenditures in the gross national product and the state budget. Major arms purchases also are made from external loans and credits. The United States and the FRG, which are interested in strengthening the bloc's southern flank, give Greece the largest amounts of military assistance. Some of these funds are intended for developing Greece's military industry. Meanwhile some reduction in the volume of U.S. military assistance has been seen in recent years.

As of FY 1989 the Greek military budget called for 382 billion drachmas (\$2.6 billion), 10 percent more than in FY 1988. There are 23.8 billion drachmas (\$160 million) allocated just for financing the program for NATO infrastructure development, which exceeds last year's level by 49.7 percent. The official military budget is 11.6 percent of the state budget, but actual expenditures will exceed this sum because of receipts through NATO channels, additional appropriations, and external loans and credits.

In recent years the Greek Department of Defense has been reducing research financing in the military sphere. Redistribution of funds within the framework of the

Directorate of the Defense Industry and reduced appropriations for independent R&D attest to insufficient effectiveness of such research with respect to creating Greece's own new models of weapons and military equipment and developing modern science-intensive technologies. Therefore the Greek government basically is orienting itself toward purchases of foreign models of arms, tying them in closely with Greece's proportionate participation in assembling and producing some components and then in licensed production. Great significance is attached at the same time to participation in the European Eureka research program by scientific research centers of the Ministry of National Education and of the Ministry of Industry's Directorate of Research and Technology as well as by Ministry of Defense research centers.

Greece participates actively in work of the NATO Eurogroup and the Independent European Programming Group, which are called upon to ensure uniformity and phased integration of West European states in the military-political sphere and the organization of joint arms production and arms standardization.

In order to develop national military industry the government proposed that at least 10 percent of orders for production of weapons and military equipment within NATO must be placed in such "small" countries as Greece. The leadership of the Independent European Programming Group is studying this question at the present time.

The western press notes that in the course of Armed Forces organizational development the Greek command is making considerable efforts to outfit the Army, Air Force and Navy with modern kinds of weapons and military equipment and to upgrade command and control assets. All these measures are being taken under pressure of the NATO leadership. At the same time, complicated relations with Turkey exert considerable influence on the Greek government's decision to accelerate the strengthening of national Armed Forces. Also of no small importance is the fact that development of military industry will permit Greece to increase the Armed Forces' self-support in weapons and military equipment and increase its own export capabilities through deliveries of weapons and military equipment to other countries, thereby providing an additional source of currency income. Under pressure of these circumstances, the Ministry of Defense considerably increased the volume of budgetary funds being allocated to develop national military industry.

The foundations of national military industry began to be laid in the mid-1970's with the technical and financial assistance of the United States, FRG, France and Austria. In 1977 this sector was reorganized and transferred to the immediate direction of the Ministry of Defense, within which a special agency, the Directorate of the Defense Industry, was established. In recent years Greece has taken vigorous steps on the path toward penetrating the world weapons market.

In order to develop national military industry the Greek military-political leadership is concentrating its efforts in the following directions: financing enterprises of the

national military industry; introducing new technological lines which would provide an opportunity to master foremost technology in producing weapons and military equipment under license; obtaining greater return from research work; rigidly controlling the increase in the number of new weapon models developed by domestic designers and the increase in the technical level of their execution; and activating cooperation within NATO with states having a developed military industry with the objective of gaining access to foremost technologies.

Six large firms presently comprise the basis of Greece's military industry—Hellenic Aerospace Industries (HAI), Hellenic Arms Industry (EBO—the abbreviation accepted in foreign publications is from the first letters of the Greek name), Hellenic Vehicle Industry (ELBO, previously known by the name Stayr Hellas), Hellenic Shipyards, Eleusis Shipyards, and Pirkal (or Greek Powder). They put out some 80 percent of the military products manufactured in the country. In addition, over 100 medium and small firms employing 50-200 persons and consolidated in SEKPY, an association of Greek military product manufacturers, participate in military production. From 20 to 80 percent of products produced by this association's firms consist of articles with a military purpose, basically spare parts and individual assemblies and machine units of combat equipment. Enterprises of Greece's military industry devote serious attention to preparing and training professional cadres, including abroad.

AIRCRAFT PRODUCTION. A plant of Hellenic Aerospace Industries (HAI Association) located in the city of Tanagra (50 km north of the capital of Athens) is the foundation of the production base of this sphere of industry. It was built in 1979 with the technical and financial assistance of the United States and France and employs 3,100 persons in production. The enterprise provides minor repairs, maintenance and modernization of all kinds of combat, transport and training aircraft and helicopters of the Hellenic Air Force as well as servicing for aircraft of other countries. In 1986 the firm signed a \$14 million contract for servicing American aircraft based in Europe.

The HAI Association has three divisions.

The Aircraft Division performs preventive inspection, repair and servicing on 24 types of aircraft and helicopters being produced by American, French and Italian firms and in the inventory of air forces of European states and countries of the Near East, Africa and North America; it also repairs and adjusts electrical, hydraulic and pneumatic systems. It has two hangars (one with an area of 9,000 m² and 22 m high, and the other of 19,500 m² and 9 m high). Two widebody and four military transport aircraft can be accommodated simultaneously in the first hangar, and 50 fighters and 12 helicopters in the second. The division also has 33 shops with an overall area of 21,000 m² in which routine servicing and maintenance can be performed on over 20 types of aircraft.

The Engine Division repairs and maintains aircraft engines being produced by American, French and Canadian firms.

The Electronics Division is responsible for repair and adjustment of navigation, optical, radio and radar equipment. Lately it also has begun to specialize in the production of communications equipment.

The Tanagra plant provides routine maintenance and major overhaul (Fig. 1 [figure not reproduced]) as well as modernization of all types of combat and transport aircraft and helicopters of the Hellenic Air Force and produces parts and some assemblies and machine units for aircraft, helicopters, engines, and air-to-air and ship-to-ship missiles.

The HAI Association produces the Pegasus reconnaissance drone developed by the KETA Military Aviation Research Center for the Hellenic Air Force. The drone weighs 130 kg, and has a fuselage length of 2.07 m and a wingspan of 5 m. It climbs to an altitude of more than 2 km and glides at a speed of 75 km/hr. A terrain image is transmitted to the ground using a television camera. In the near future HAI in cooperation with the Italian firm of Agusta intends to begin producing an antisubmarine version of the A.109 helicopter (the fuselages of these helicopters already were assembled here previously on an order from Italy).

In April 1986 the Greek government signed a 15-year agreement with the French companies of Dassault-Breguet, SNECMA and Thomson-CSF for licensed production of assemblies and machine units for the Mirage-2000 tactical fighter. A contract with SNECMA, which produces engines for these aircraft, provides for assembling 50 M53 engines at the Tanagra plant. Forty of these are intended for the Hellenic Air Force and ten for the French Air Force. Signing of the contract became possible after conclusion of an agreement on France's delivery of 40 Mirage-2000 aircraft to the Hellenic Air Force. Production of parts and assemblies of the wing, fuselage as well as navigation equipment is planned in Greece. The contract was worth one billion French francs.

An agreement has been signed with the American General Dynamics Corporation for licensed production of a number of assemblies and machine units of engines for F-16 Fighting Falcon tactical fighters being purchased by the Hellenic Air Force. In October 1986 HAI concluded a contract with the U.S. firm of Northrop on licensed production of the BAM-74C remotely controlled reconnaissance drone (Greece designation Telamon), which can be launched from land, from a ship and from an aircraft.

Hellenic Aerospace Industries repairs and maintains engines of Mirage F1 tactical fighters and T-2E combat trainer aircraft and performs periodic technical servicing on Sidewinder and Hawk missiles in the inventory of the Hellenic Air Force and air forces of other NATO countries under contracts with the firms of Dassault-Breguet

and SNECMA. Under existing agreements HAI services C-130 Hercules transport aircraft belonging to Nigeria, Jordan and Canada as well as engines of aircraft of the U.S. and UK air forces.

Like HAI, the **Athens State Aircraft Plant**, at which up to 400 persons work, repairs combat aircraft of the Hellenic Air Force. On the whole, up to one-third of the Greek aircraft industry production capacities is used for routine servicing and maintenance of aircraft of NATO countries and Near Eastern states.

ARMORED EQUIPMENT PRODUCTION. The basic capacities of this sector of the industry are located in the cities of Salonika, Athens and Velestion.

The Greco-Austrian joint enterprise of **Hellenic Vehicle Industry (ELBO)**, the former Stayr Hellas, is one of the largest firms of the armored industry. The state has a 60 percent share of the firm's capital. Its plant is located near the city of Salonika in the northern part of the country. It was built in 1972 and specialized in producing prime movers, tractors and so on. In 1979 the enterprise shifted to state control and presently is producing military vehicles and vehicle engines. It employs some 1,000 persons. Up to 90 small firms fill orders of this head plant. Its products go basically for export, the bulk of which consists of military trucks, APC's, engines and special equipment also are supplied to the foreign market. The firm is faced with the task of fully meeting the needs of the Greek Armed Forces for military vehicles. It produces the 680 MH and 680 MH-3 military trucks and produces Leonidas APC's under license from the Austrian firm of Stayr-Daimler-Puch (Fig. 2 [figure not reproduced]).

In 1986 Hellenic Vehicle Industry began producing the Daimler-Benz 240 GD jeep-like light army vehicles with high off-road capability for the Greek Army under West German license. By the end of that same year 500 vehicles already had been delivered and it is planned to produce a total of 5,000.

The **Salonika Vehicle Plant**, which employs some 2,500 persons, produces Leonidas APC's under Austrian license and also repairs APC's in the Greek Army inventory. Production of SK-105 Kurassier light tanks under Austrian license is being mastered.

The **Velestion State Tank Plant** repairs and modernizes U.S. M48 tanks and M113 tracked APC's, French AMX-30 tanks and West German Leopard-1 tanks.

ARTILLERY AND SMALL ARMS PRODUCTION is organized by the firm of **Hellenic Arms Industry (EBO Association)**, which includes a number of industrial enterprises located in the cities of Egion, Kimi, Mandra, Ioannina and Lavrion. Beginning in 1979 the firm turned from being a licensed producer of a single kind of weapon (West German G3 7.62-mm rifles developed by the firm of Heckler & Koch) into a multiprofile enterprise actively engaged in research and planning activities in the military equipment area. Ten percent of the firm's

permanent employees are involved in this. Up to 2,000 persons work at EBO enterprises and the annual turnover is \$67 million. The Association belongs to the state. The ministries of Defense, Finance, and National Economy have 70 percent of the stock while 30 percent belongs to the Hellenic Industrial Development Bank.

In the opinion of western military analysts, the key direction in development of this sector of industry was the development of the Artemis-30 antiaircraft artillery gun in cooperation with the FRG and Sweden; deliveries to the Greek Armed Forces began in 1987. In addition, the firm developed and began producing new types of powders and explosives used in the production of two new kinds of 155-mm caliber ammunition, Hermes and Hera, which led to a substantial increase in range. Over half the ammunition of this type is exported. On the whole the Association is oriented toward developing new kinds of conventional arms and expanding export capacities. One of its plants is located in the city of Egion. Funds which came through FRG military assistance channels were used in constructing it. At the present time it is producing medium-caliber gun barrels, rifles, light and heavy machineguns, assault rifles, pistols, 81-mm mortars (Fig. 3 [figure not reproduced]) (in which ammunition of U.S., French and British production can be used), and 20-mm and 30-mm antiaircraft guns. This plant continues to modernize the Artemis-30 antiaircraft artillery gun. The gun is being assembled at the Kimi Plant, which also produces assemblies and parts of fire control systems and electrical equipment of artillery systems.

In 1982 Hellenic Arms Industry bought up the stock of the General Engineering Plant in Mandra and the Epiro Metalworks in Ionnina, which presently manufacture parts for fuselages, suspended fuel tanks, pylons, cargo suspension systems as well as certain components of ammunition and produce carriages for the Artemis-30 antiaircraft artillery gun. In addition, the Association is building a fifth plant in the city of Kimi. The plants' design bureaus are developing a 120-mm mortar, and preparation of M114 howitzers for production is concluding (they will be delivered to the Greek Army). Heads of the firm are considering the possibility of establishing joint ventures with the involvement of capital and technology of European firms for producing electronic equipment as well as elastic materials, nitrocellulose and TNT for export. Products of the EBO Association are supplied basically to developing countries and NATO member states. Hellenic Arms Industry presently is the "most dynamically developing firm in the country," in the opinion of foreign analysts.

In addition, the Mandra Plant is producing 30-mm guns under license from the West German firm of Mauser and the Ionnina Plant is producing shell cases of various caliber which are filled at the plant in Lavrion. The plant in the city of Corinth produces small arms and 90-mm recoilless guns.

AMMUNITION AND EXPLOSIVES PRODUCTION meets the needs of the Greek Armed Forces for field and antiaircraft artillery ammunition as well as small arms ammunition. A considerable portion of the products is exported. Some 5,000 persons are employed in this sector of the industry. Plants are located primarily in the southern part of the country in the Athens area.

Three state plants in the cities of Athens, Lavrion and Eleusis are the foundation of the production base. They produce projectiles in calibers from 20 to 203.2 mm, ammunition for mortars and rocket launchers, small arms cartridges, fuzes, TNT, dynamite, hexogen, smokeless powders, hand grenades, and antitank and antipersonnel mines.

The firm of **Pirkal (Greek Powder)**, founded in 1974 to satisfy the requirements of industry and the Army for powder, dynamite, ammunition and small arms, is the largest in this sector. Since 1982, when the firm shifted to state control, the volume of products has increased considerably, which permitted beginning export deliveries to the United States and other NATO countries. In 1986 the export volume of the firm's products exceeded the volume of deliveries to the domestic market (\$82 million as opposed to \$67 million) for the first time. Countries of the Far and Near East and Africa are the main sales markets. Military deliveries to the United States considerably increased in 1987-1988.

The firm exclusively produces those kinds of products needed for the country's Armed Forces. This is dictated in particular by the fact that 95 percent of military budget funds allocated for development of the ammunition production industry are placed at the disposal of Pirkal. Other firms involved in this sector of military industry supply the Armed Forces only with practice grenades and antiaircraft rounds. At the present time Pirkal is not specializing in the production of explosives and powders, which are produced exclusively by the EBO Association.

Pirkal's head plant, located in an Athens suburb, specializes in manufacturing metal parts for ammunition. Two plants in the city of Eleusis produce powders and explosives and also fill ammunition and perform final assembly of it. Some 4,000 persons are employed in the firm's plants.

Pirkal performs joint research with firms of Italy, Switzerland, France, the FRG, Belgium, Norway and the United States. It produces shell cases of various calibers, ammunition for howitzer artillery, projectiles for a 105-mm tank gun and the Vulcan rocket launcher, and fuzes.

In 1981 plants were built within the EBO Association in the city of Lavrion (60 km from Athens) for the production of powders and ammunition on order of the Greek government; they presently represent the largest complex of this profile in Europe. They produce various types of powders and explosives. There is a plant for filling large and medium caliber ammunition and also aerial bombs.

An enterprise for producing TNT was placed in operation in late 1987. In the assessment of western specialists, on completion of its construction Greek industry, including the military industry, fully satisfies its requirements for chemical components needed for producing powders and explosives.

ELECTRONICS PRODUCTION. Greece has no industrial base for creating complex electronic systems and their components. A plant of the firm **Alpha SAI** in Athens, a plant of the firm **Hellenic Electronic Industry**, and enterprises in the cities of Athens (for repairing tank and APC instruments and equipment) and Piraeus (for repairing electronic and navigation equipment) specialize in manufacturing military products in this sector.

The private firm of **Hellenic High Technology (HHT)** produces SEM 172 portable HF radio transmitters and SEM 180/190 radios installed in military vehicles under license from the West German firm of Standard Elektrik Lorenz. The firm supplied the Hellenic Navy with five Kanaris tactical data processing and fire control systems for Type 209 submarines. A new modification of this system is being developed for employing the Harpoon antiship missile.

Hellenic Aerospace Industry developed the Pythagorus automated fire control system. For the last three years the firm of Alpha SAI has been producing electronic fuzes used in mortar ammunition and in 76 to 203.2 mm artillery rounds. The firm of **Ekonomidis & Sons** signed a contract with a U.S. company for producing high technology subsystems for surface-to-air missile systems.

SHIPBUILDING. This sector of the industry has not been developed in Greece. There are no specialized military shipyards in the country.

According to western press data, greatest activity in the shipbuilding sphere was observed in 1979, when the government placed orders with the country's shipyards for building patrol boats for the Navy, Coast Guard and Customs Service. Six "A. Laskos"-Class ("La Combatante III"-Class, Fig. 4. [figure not reproduced]) missile craft equipped with ship-to-ship guided missiles, torpedoes and antiaircraft guns were built under French license and ten patrol boats were built under West German license for the Hellenic Navy at shipyards of the Hellenic Shipyards Company during 1980-1982. Some 160 ships of the U.S. Sixth Fleet have undergone repair here over the last 15-20 years. The Hellenic Shipyards Company shipyard in Skaramanga was nationalized in 1985 and Hellenic Navy orders presently are placed with it. Preparations are being made here for building the first guided missile frigate for the Hellenic Navy (design cost \$160-180 million). It is planned to build a total of eight frigates in two phases. The company also is holding talks with a number of Near Eastern countries about possibilities of receiving orders from them for the construction, modernization and repair of various types of ships.

Hellenic Shipyards has three floating drydocks of 30,000, 25,500 and 22,000 tons and two drydocks of

500,000 and 250,000 tons. The first drydock is considered the largest in the Eastern Mediterranean.

The Hellenic Navy placed an order with shipyards of the **Eleusis Shipyards Company** for building four landing ships with a displacement of 4,400 tons and a length of 114 m capable of carrying tanks and heavy armored vehicles. The work of building the first ship began in December 1986 and she was launched in 1988. The other landing ships will leave the ways at five-month intervals. The Eleusis shipyard also produces patrol boats. Further modernization of the yard is planned, which will provide an opportunity for building ships of a larger type.

At the present time up to 5,000 persons are employed in the country's shipbuilding industry. The Greek government subsequently intends to make fuller use of the capacities of shipyards, taking into account the experience gained in the shipbuilding sphere.

On the whole, western military experts believe that Greece's military industry is in the process of development and modernization. The country's military-political leadership is pursuing the goal of raising the level of Armed Forces' outfitting by upgrading the national military industry, mastering foremost production technologies, elevating them to the level of NATO demands, and creating arms models that are competitive on the international market.

The government encourages the signing of contracts with firms of the FRG, United States, France and Italy for joint production of weapons and military equipment, which in its opinion should ensure Greek specialists of access to foremost U.S. and West European technology. Steps also are being taken to increase export capacities of the military industry. In view of the low level of the national scientific and experimental base for manufacturing weapons and military equipment, however, primary emphasis is placed on licensed production as well as on cooperation with foreign firms in the development and production of new kinds of arms.

COPYRIGHT: "Zarubezhnoye voyennoye obozreniye", 1989.

Dutch Civil Defense

904Q0001M Moscow ZARUBEZHNOYE
VOYENNOYE OBOZRENIYE in Russian
No 8, Aug 89 (signed to press 23 Aug 89) pp 68-73

[Article by Col (Res) V. Yemelyanov]

[Text] The military-political leadership of the Netherlands, as of other North Atlantic Alliance member countries, views measures for upgrading civil defense [CD] as a necessary part of military preparations. CD organizational development is being accomplished in the country with efforts in this sphere coordinated by the CD Committee, which is part of the NATO Main Committee for Emergency Civil Defense Planning, and in close coordination with neighboring bloc countries, especially in the

area of upgrading such CD components as the population warning system as well as the radiation reconnaissance and dosimetric monitoring service.

NATO regards Dutch CD as among the most developed. It began to be established in 1952 after adoption of a law on civil defense, which specified the initial organizational structure and missions of the CD system. Subsequently this law was supplemented by new provisions in accordance with government decrees. In 1984 the "Dutch Ministry of Home Affairs Note on Civil Defense" was published, setting forth basic directions and plans for upgrading CD for the period 1985-1989 and making additions and certain amendments concerning its organizational structure and the numerical strength of formations.

The Dutch press points out that one of the basic tasks of national CD is to establish and train forces needed above all for mopping up in the aftermath of the use of nuclear weapons and other mass destruction weapons and for performing other functions aimed at ensuring protection and survival of the civilian population. Dutch CD forces and assets are used in peacetime for the work of preventing or mopping up in the aftermath of floods (coastal areas are subject to flooding), other natural disasters and production accidents.

Overall direction of national CD is exercised by the Ministry of Home Affairs through the Main CD Directorate set up under it (Fig. 1). The country's territory is divided into 12 CD districts (according to the number of provinces). This kind of activity in a district is directed by the provincial commissar, while the district CD chief and his staff are the immediate organizers of work. In peacetime the staffs are manned only by command personnel and a small number of technical personnel. As a rule they are expanded to wartime tables of organization for the period of appropriate exercises.

CD districts consist of 45 areas categorized in groups A and B. In wartime it is planned to have 51 areas. Group A CD areas include territories on which large cities, rail centers, and important military and industrial installations are located. Group B CD areas are formed basically in the country's agricultural regions. An area's directing entity is a council which includes commune burgomasters and the area CD chief with his staff (Fig. 2 [figure not reproduced]). Just like the CD district staff, the area staff is manned in peacetime only by command personnel and technical personnel, and is expanded to wartime tables of organization only for the period of exercises or under emergency conditions.

Group A CD areas are divided into sectors. It is planned to have 60 of them in wartime. Corresponding CD formations are assigned to each sector for the period of an emergency. The senior chief of one such formation is at the same time the CD sector chief.

Commune CD is directed by the burgomaster through the commune CD chief and chiefs of respective services (firefighting, medical, police, public utilities and social

Fig. 1. Organizational structure of the Dutch CD system

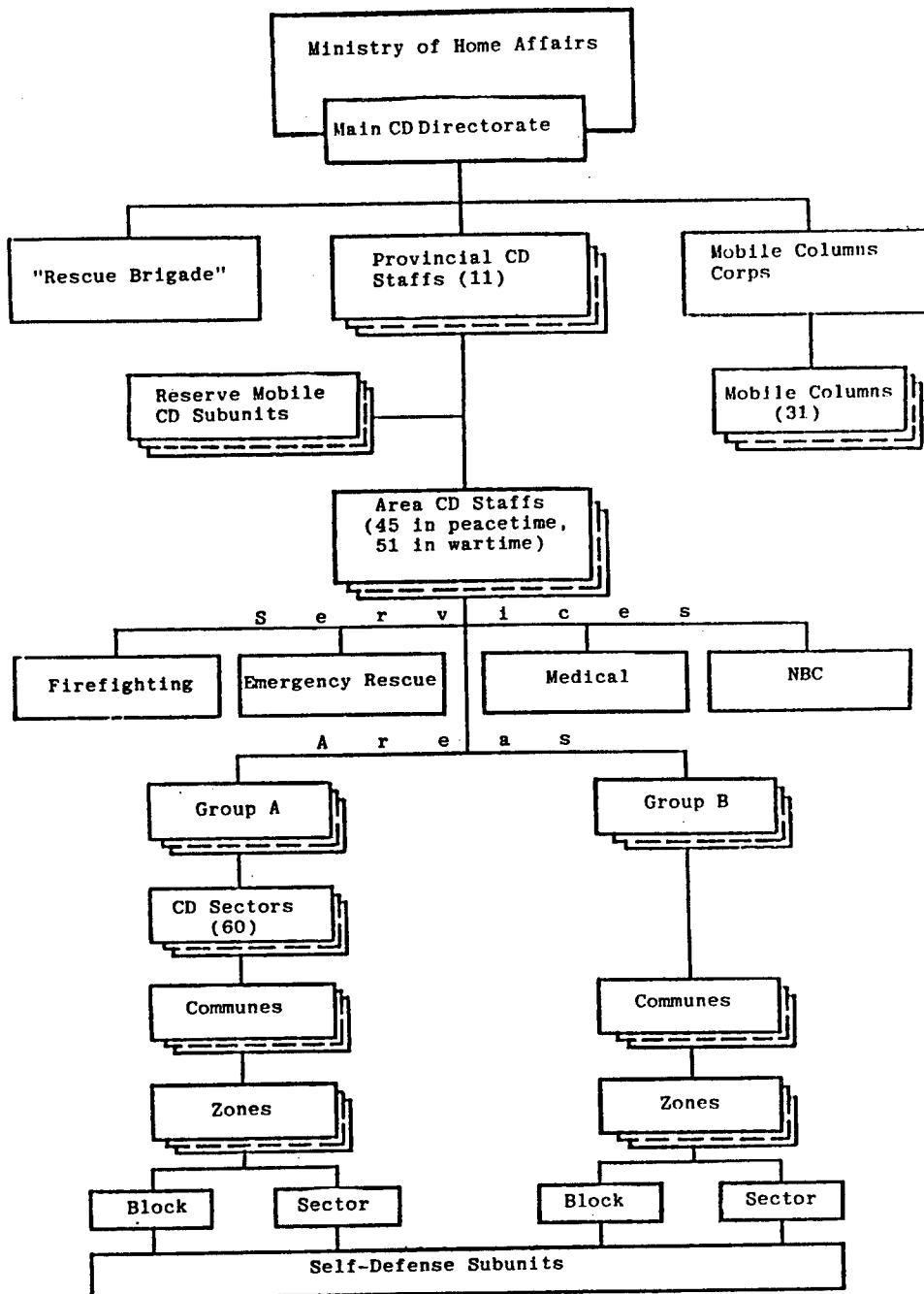

security). Communes are divided into zones and the zones into blocks (in cities) or sections (in a rural area). There are self-defense subunits in zones, blocks and sections.

An installation self-defense chief is appointed and volunteer formations of various CD services are established at enterprises and establishments with 30 or more

employees. The foreign press reports that in an emergency it is planned to bring the strength of self-defense formations in industrial, commercial and other enterprises and establishments to approximately 110,000 persons.

As emphasized in the Ministry of Home Affairs Note on Civil Defense, CD must be prepared to perform its

functions not only in a period of an emergency, but also in peacetime (during natural disasters and industrial accidents), and it must have the forces and assets necessary for this. In recent years, however, principal efforts have been concentrated on the preparing measures to be accomplished within the framework of the overall NATO civil defense program for a wartime period. In this regard a so-called "rescue brigade" was detached from the Army and placed at the disposal of CD entities in addition to their own forces for performing rescue and emergency repair operations in case of natural disasters and major production accidents in peacetime.

The brigade includes two mechanized battalions each numbering 650 persons, three companies—medical (130 persons), engineer (146 persons) and transportation (125 persons and 60 trucks)—as well as a military police platoon (30 persons) and medical squad (11 persons). Brigade alert subunits are in constant 15-minute readiness for action. Aircraft and helicopters are provided from Army aviation for airlifting the brigade.

It is proposed to deploy a mobile columns corps as part of CD forces for the period of an emergency. The Ministry of Defense is responsible for its formation. Up until 1984 it was planned to have 23 mobile columns (including rescue, medical and firefighting columns) in the corps. In accordance with the Note on Civil Defense, it is planned to increase their number to 31 by creating new rescue and medical columns. Seven of them (rescue and medical) are to be transferred to chiefs of CD districts of certain provinces (one column each for North Holland, Overijssel, Utrecht, North Brabant, and Limburg; and two columns for South Holland).

The strength of the firefighting column (there are 12 of them) reaches 790 persons. Its T/O&E also includes 150 pieces of transportation and special equipment. The rescue column has 1,060 persons and consists of 48 rescue groups, 12 combat engineer groups, an engineer detachment and a water purification platoon. Some 190 pieces of various transportation and special equipment as well as three water purification sets (each with a capacity of from 100 to 150 m³ of potable water per day) are attached to it. The medical column (890 persons) has over 190 pieces of transportation equipment, including ambulances as well as stores of necessary gear, drugs and bandages sufficient to assist 75,000 persons.

In peacetime all mobile columns are maintained at reduced strength levels. Only the staffs are manned, and there is a minimum number of specialists engaged in servicing and maintaining vehicles and special equipment. The rest of the personnel (primarily first priority Armed Forces reservists who have undergone civil defense training and have been assigned to corresponding columns) are periodically brought in for assemblies and for rehearsing various missions during exercises. The western press announces that a total of up to 30,000 persons are registered with mobile columns.

In addition to those formations directly subordinate to central CD entities, CD district chiefs have reserve mobile CD subunits (also manned by Armed Forces reservists) intended for assisting areas that have suffered most. Their overall strength exceeds 4,000 persons.

Subunits of basic services—firefighting, emergency rescue, medical, and NBC—have been established in each civil defense area. In peacetime they are used for mopping up in the aftermath of natural disasters and production accidents. Emergency assistance detachments have been formed in the largest cities for rapidly penetrating areas of physical destruction, performing rescue operations there, and preventing the development of centers of fire or development of individual fires into continuous fires. Their makeup is determined by the municipalities.

It is planned to assign 85 firefighting companies, 60 rescue platoons, 60 support groups, 69 reconnaissance platoons, 60 medical platoons and 375 ambulances to CD areas and CD sectors in addition to local forces for the period of an emergency, and to deploy 60 casualty collecting stations.

Self-defense is organized in residential areas by forming subunits of volunteers by block, by groups of houses and by individual houses. In wartime it is planned to have at least four self-defense groups (15 persons in each) in each block.

The population warning system through Dutch civil defense channels includes a main warning center, warning centers and points of CD districts and areas, and also special warning posts equipped with means for getting the warning signal to the population. The main warning center is located together with the country's central air defense command post, from which it receives the initial warning signal about the threat of air attack and transmits it to appropriate district centers. Then the warning signal goes to CD area warning points, from which the sirens at warning posts are turned on. Judging from foreign press publications, the country has a total of over 300 sirens. Their operation is checked on the first Monday of each month from 1200 to 1215 hours by turning them on to partial volume.

Civil telephone channels placed at the disposal of CD entities in wartime and for an exercise period comprise the basis of the Dutch CD communications system. Radio-relay communications equipment has been installed at command posts of CD district staffs and of some of the most important CD area staffs; this equipment can be included in the country's overall radio-relay communications system if necessary. In an emergency it is planned to place up to 300 fixed, some 1,100 mobile (vehicular) and over 1,500 portable radios at the disposal of CD areas. A system of closed-circuit automatic telephone communications for government entities and civil defense is in the final stage of construction. This system's

telephone stations are accommodated in protected facilities, and telephone communication channels with command and control entities at various levels are connected to them.

The probability of the country's territory being contaminated by radioactive fallout in case of nuclear war and the possibility of such contamination in peacetime from accidents at enterprises with fissionable materials required creation of a radiation, chemical and bacteriological reconnaissance and dosimetric monitoring service in the Dutch CD system. It is based on companies and separate platoons attending 300 radio-equipped fixed posts and 600 mobile posts. The companies have subunits for radiological and gas decontamination which can be reinforced if necessary by a radiation reconnaissance and radiological decontamination company at the disposal of each CD district staff. Each such company (there are 12) has 24 mobile radiological decontamination units. Moreover, the chief of the Main CD Directorate can order additional forces from adjacent CD districts to be sent to parts of the country that have suffered most.

Population protection within the framework of this country's civil defense is accomplished chiefly by creating a network of protective facilities on its territory (Fig. 3. [figure not reproduced]). It is planned above all to use basement spaces suitable for additional outfitting in existing buildings and buildings under construction for building public and private shelters and refuges. In addition, it is planned to use tunnels and subway stations in the cities of Amsterdam and Rotterdam as shelters, as well as to use dual-purpose facilities (underground garages, Fig. 4 [figure not reproduced]), indoor ranges, gymnasiums, coffeehouses and so on).

The Dutch government considers evacuation as a method of population protection to be an extreme measure and so it is not a determining factor in elaborating population protection measures. As in a number of other Central European NATO member states with small territories, high population density and high concentration of industrial enterprises, the country's military-political leadership adheres to the "stay put" concept, i.e., it recommends that the population remain in place and occupy spaces suitable for antiradiation protection in case of an emergency.

The decision to evacuate a particular area of the country will be made directly by the government in each individual case. At the same time, probable areas to be evacuated already have been determined in advance, chiefly places located near installations where nuclear and chemical components are used. Movement routes also have been worked out, transport equipment has been calculated, and the work of outfitting areas for receiving evacuees has been planned. A special commission under the Ministry of Home Affairs exercises overall direction over measures of preparing and conducting an evacuation. A commissar for evacuation is

responsible for these matters in the provinces, and the director of the evacuation commission is responsible for it in communes.

Organization of medical support to the country's populace in an emergency period is the responsibility of the Ministry of Health. The country's existing hospital network permits accommodating up to 65,000 patients. Two hundred fifty public and private buildings have been registered in which medical facilities can be temporarily accommodated if necessary. Additionally it is planned to establish a reserve of medical facilities for 50,000 beds.

Over 250 medical detachments have been formed from volunteers under the aegis of the Dutch Red Cross Society (some 12,000 members). Periodic drills are held with the personnel on assisting victims of natural disasters. The Red Cross has a network of medical equipment and medical supply depots. The Society's main depot in the Hague stores everything necessary for deploying hospitals for 2,000 beds. In addition, more than 120 small depots are evenly distributed throughout the country's territory.

The foreign press notes that civil defense entities, services and formations are manned on a mixed basis, i.e., using reservists (service in civil defense equates to service in the Armed Forces) and volunteers (in the ages from 18 to 60).

The heads of the country's CD and officers of the mobile columns corps undergo training at the higher civil defense school in Barneveld, and NCO's and privates train in the mobile columns corps training center (near the city of Bussum). Specialists of firefighting, rescue and medical subunits of the mobile columns corps as well as instructors and leaders of self-defense subunits train in three civil defense training centers (Wieringerwerf, Doorn and Steenwijkerwold). Personnel of self-defense groups and posts train at permanent local courses (for some 30 hours) and annual two-week assemblies at civil defense training centers.

The country's CD staff command post is set up in a semiburied reinforced concrete structure built during World War II (near the city of Utrecht, 30 km southeast of Amsterdam). Command posts for CD district staffs also are in reinforced concrete structures left after World War II. There are protected command and control facilities in all CD areas, built according to a standard design. They are buried reinforced concrete structures which can hold up to 50 persons on the CD area staff. The command and control facilities are equipped with air filtration and ventilation systems and emergency power sources and are supplied with reserves of water, food and medicines.

The Dutch CD leadership attaches great significance to organizing scheduled daily operational training of CD forces and assets which is coordinated with appropriate NATO entities. The country's CD subunits take an active part in almost all exercises conducted within the

bloc framework. They include above all the Wintex integrated exercises of NATO Allied Forces and the annual Intex NATO CD Exercise. As a rule, CD forces and assets of various levels take part in them. In addition, each year up to 20 staff exercises and drills involving the personnel of CD staffs, services and formations and at least four exercises of mobile columns corps subunit personnel take place in the country. Exercises of the country's CD forces and assets are held on the first Monday of every month, and the firefighting service and the Red Cross Society also take part in them.

The population is prepared in civil defense by CD and Red Cross Society entities through wide propaganda of questions of protection and self-defense against mass destruction weapons, first aid and so on. Popular pamphlets on various aspects of civil defense including recommendations on additional equipping of one's housing for use as shelters and refuges in a period of threat (or in advance) and on setting up necessary stores of water, food and medicines at home are published in a mass printing. The journal NOODZAAK is the official printed organ of Dutch CD and is published eight times a year. In addition, CD personnel receive an information bulletin covering CD problems.

As noted in the "Dutch Ministry of Home Affairs Note on Civil Defense," CD expenditures are allocated from budgets of the Ministry of Home Affairs (around 52 percent), the Ministry of Defense (approximately 20 percent) and other ministries (over 28 percent), chiefly the Ministry of Transport and Public Works (10 percent), Ministry of Health and Social Security (9 percent), and Ministry of Economic Affairs (4 percent).

Appropriations for CD have grown by approximately a third in recent years. For example, while 110 million guildens were allocated for these purposes in 1981, CD expenditures reached 145 million guildens during 1988-1989.

COPYRIGHT: "Zarubezhnoye voyennoye obozreniye", 1989.

New Depleted Uranium Production Plant

904Q0001N Moscow ZARUBEZHNOYE
VOYENNOYE OBOZRENIYE in Russian
No 8, Aug 89 (signed to press 23 Aug 89) p 74

[Article by Col P. Apagoshin]

[Text] Great Britain's Ministry of Defence decided to build a depleted uranium production plant at the Aldermaston Nuclear Research Center. Depleted uranium now is produced in Great Britain only at one plant belonging to the above center in the city of Cardiff (Wales, Glamorganshire County).

What is the need for such material? The western press attests that this product is needed to fulfill the program

for deploying the Trident sea-based nuclear missile system and creating new antitank (armor-piercing) ammunition.

Under the first program it is planned to commission four new-generation SSBN's (two already are being built) in the country by the mid-1990's to replace submarines armed with Polaris-A3TK missiles. The SSBN's will be armed with 16 U.S. Trident II SLBM's. Their MIRV re-entry vehicle is being developed in Great Britain and will contain eight individually targeted warheads. Depleted uranium is used in the re-entry vehicles of these missiles as a protective envelope (reflector) around the nuclear warhead of plutonium and enriched uranium.

Under the second program the state company known as Royal Ordnance Factories presently is developing new ammunition where depleted uranium is used in manufacturing the cores of armor-piercing discarding sabot projectiles for 120-mm guns to be installed in Challenger II tanks (the U.S. Army has been using this material in producing tank ammunition since the 1970's). In addition, last year the United States officially declared that depleted uranium is a component of new armor for M1A1 Abrams tanks.

In accordance with the project, the new plant's area will be 8,750 m². A rolling mill, super-powerful press and heat-treating shop will be situated on this territory in support of technological processes.

COPYRIGHT: "Zarubezhnoye voyennoye obozreniye", 1989.

Belgian Center for Unexploded Chemical Ordnance Disposal

904Q0001O Moscow ZARUBEZHNOYE
VOYENNOYE OBOZRENIYE in Russian
No 8, Aug 89 (signed to press 23 Aug 89) p 74

[Article by Col V. Elin]

[Text] The Belgian Ministry of Defense plans to build a special center in the northern part of the country (populated point of Poelkappele) for disposing of unexploded chemical ordnance which remained after World War I and which still is regularly found despite the seven decades that have passed. Usually it is discovered on the surface of the soil as a result of soil erosion or when construction work is being done at battle sites.

Such ordnance makes up approximately a tenth of the 200-300 tons of unexploded ordnance left after both world wars and discovered annually.

This center (preliminary cost \$4 million) is to become operational in 1991. In the assessment of Belgian specialists, its production capacities will permit disposing of some 20 tons of such objects per year. But its primary task will be to dispose of the approximately 200-ton "reserve" of chemical ordnance (filled primarily with

mustard gas) which has accumulated in Poelkappele over the last eight years. It formed as a result of the stockpiling there of old chemical ordnance that had been discovered and due to the absence of a reliable method of destruction after Belgium stopped burying old ordnance in the North Sea in accordance with a convention signed in Oslo.

A special robot will be used to extract fuzes (usually contact fuzes) and remove toxic agents from the ordnance. The robot's use will reduce the level of risk for attendant personnel. The foreign press has announced that several dozen persons who dispose of such ordnance have died since 1945. The last tragedy which took the lives of four soldiers occurred in 1986 when an old bomb was being unloaded from a truck.

Toxic agents that are removed are to be destroyed by burning either in Belgium or in one of the neighboring countries where there is appropriate equipment.

COPYRIGHT: "Zarubezhnoye voyennoye obozreniye", 1989.

REPORTS, EVENTS, FACTS

U.S. 1st Cavalry Division (Armored)

904Q0001P Moscow ZARUBEZHNOYE
VOYENNOYE OBOZRENIYE in Russian
No 8, Aug 89 (signed to press 23 Aug 89) p 75

[Article by Col I. Vanin]

[Text] The 1st Cavalry Division (Armored) stationed at Fort Hood, Texas (the emblem is shown in the figure [figure not reproduced]) is one of the large units of the U.S. Armed Forces intended for reinforcing the U.S. force grouping in the European zone. With consideration for the significance of this large unit, the American command maintains it as one of the "dual based" divisions, for which heavy weapons and military equipment have been stockpiled on the territories of a number of European states (with the objective of reducing time periods for movements from the continental United States to Europe).

The division presently includes only two brigades and is to be brought up to wartime T/O&E strength under mobilization deployment plans with the 155th Separate Armored Brigade of the Army National Guard. After being moved and deployed in the European theater of war, the division will include a headquarters and headquarters company, three brigade headquarters, six tank battalions, four mechanized battalions, an artillery division (MLRS battery and three battalions of 155-mm self-propelled howitzers), an army aviation brigade, air defense battalion, signal battalion, engineer battalion, intelligence and EW battalion, division support command, military police company and NBC company. It will have a total of 16,600 persons, 348 M1 Abrams tanks, 216 M2 Bradley infantry fighting vehicles, 118

M3 combat reconnaissance vehicles, 160 M577A1 command and staff vehicles, 336 M113A1 APC's, 72 155-mm self-propelled howitzers, 9 MLRS launchers, 48 M901 TOW self-propelled antitank missile systems, 240 Dragon antitank missile systems, 66 106.7-mm self-propelled [SP] mortars, 18 Improved Chaparral surface-to-air missile systems, 36 Vulcan SP AA guns, 36 Stinger portable SAM systems (fire teams), 127 helicopters including 44 AH-64A Apache fire support helicopters, as well as some 3,900 vehicles and over 5,300 radios.

Western military specialists assume that this division's movement to Europe will increase the combat capabilities of NATO Allied Forces in the initial stage of strategic deployment of the bloc's Armed Forces. The division has high firepower, striking power, tactical mobility and capability to conduct lengthy combat operations

COPYRIGHT: "Zarubezhnoye voyennoye obozreniye", 1989.

NATO Allied Forces Exercise in the Baltic Approaches

904Q0001Q Moscow ZARUBEZHNOYE
VOYENNOYE OBOZRENIYE in Russian
No 8, Aug 89 (signed to press 23 Aug 89) pp 75-76

[Article by Col V. Zelenov]

[Text] A NATO Allied Forces exercise in the Baltic Approaches codenamed Bold Grouse-88 was conducted from 22 August through 23 September 1988 (within the scope of the annual series of Autumn Forge fall maneuvers of the bloc Armed Forces). The objective of the exercise was to check plans for reinforcing the NATO force grouping on the Danish Islands and their combat employment (during an antilanding defense).

Army, air force and navy units and subunits of Great Britain, the FRG, Denmark and other member countries were involved in the exercise.

Operating on the Blue side were the UK 1st Mechanized Brigade reinforced by tank and helicopter subunits, and the 1st Sjaelland Mechanized Brigade, Home Guard formations and the 3d Reconnaissance Battalion of the Danish Army Eastern Command. The Orange was represented by the Danish 2d Sjaelland Mechanized Brigade as well as by the 272d Airborne Battalion and Bundeswehr Navy amphibious group. NATO Allied Forces groupings in the Baltic Approaches were built up according to plan chiefly by the movement of British troops.

Problems of conducting highly mobile offensive and defensive operations were rehearsed during the exercise, with special significance attached to a practical check of provisions of the "active (mobile) defense" concept.

According to the initial situation the British brigade main body was deployed southwest of Copenhagen,

forces of the 1st Sjaelland Mechanized Brigade in the central part of Sjaelland Island, and the Danish 3d Reconnaissance Battalion in its southern part. The Orange landed assault forces as follows: two amphibious forces on Falster Island and north of Copenhagen and two airborne forces in the central part of Sjaelland Island. The second amphibious force was to have linked up with the airborne forces and created a threat to the Danish capital. That same day the British brigade delivered an attack against the second amphibious force, the Danish brigade delivered an attack against the airborne forces, and the reconnaissance battalion was shifted to Falster Island and began conducting delaying actions against the first amphibious assault force.

The Orange amphibious forces on Sjaelland Island succeeded in widening the bridgehead by pressing back the British, but the Blue managed to avert an unfavorable development of the situation by a rapid regrouping and forward movement of the Danish brigade (which had completed "destruction" of airborne forces) against the flank of the amphibious forces. Orange attempts to prevent this using airmobile subunits inserted in the Blue rear by helicopters proved unsuccessful.

Having received reinforcements, the Orange achieved considerable success on Falster Island. Driving back the reconnaissance battalion's forces, they made an assault crossing of the strait and forced Blue screening subunits to withdraw to Sjaelland Island. At the same time a third airborne force was landed in the latter's rear with the mission of disorganizing or delaying the forward movement of the Blue from the north.

Then the Orange attempted to land one more amphibious assault force south of Copenhagen, but this failed. The Orange employed chemical weapons in the situation at hand to disrupt the regrouping of Blue forces. Despite this, British troops were able to take up a defense in the southern part of Sjaelland Island and prevent the enemy from advancing into the island's interior, while the 1st Sjaelland Brigade concentrated to the north, establishing a grouping second echelon. After this the Blue counter-attacked and disrupted Orange attempts to consolidate on the captured line. Rehearsal of operational training missions ended with this.

Western experts note that methods of conducting a mobile defense used in the exercise also can be used under other conditions and can be combined with a static defense supplemented by maneuver. In addition, they estimate that this exercise also had political significance. As stated at a press conference at the end of the exercise, it showed that the country's Armed Forces were "in no condition to defend their territory without support of NATO allies." Such a statement fully suits Denmark's senior partners in the North Atlantic Alliance, and above all the United States and Great Britain, which are interested in tying this country closer to the bloc.

COPYRIGHT: "Zarubezhnoye voyennoye obozreniye", 1989.

Development of the U.S. C-17 Military Transport Aircraft

904Q0001R Moscow ZARUBEZHNOYE VOYENNOYE OBOZRENIYE in Russian No 8, Aug 89 (signed to press 23 Aug 89) p 77

[Article by Col Yu. Pavlenko]

[Text] Judging from foreign press announcements, the firm of McDonnell Douglas, which is developing the new C-17 military transport aircraft, has encountered difficulties involving onboard computer system software and being significantly over the aircraft's given weight.

Despite active searches for ways to overcome the problems that have arisen, fulfillment of the program for creating the aircraft is lagging behind previously planned time periods by 12-16 weeks, based on a statement by a U.S. Defense Department representative. According to forecasts of Air Force specialists, it will be possible to begin flight tests only in early 1991 and not in August 1990 as had been planned. But the time period for beginning aircraft deliveries to the Air Force, planned for the third quarter of 1991, remained unchanged. It is planned to purchase a total of 210 aircraft of this type for MAC up to the year 2000.

A representative of the manufacturing firm expressed confidence that software problems will be resolved in the final account. At the same time, the excess weight problem forced designers to accept certain changes in the aircraft's specifications and performance characteristics. For example, maximum take-off weight rose from the 112.5 tons previously envisaged to 122 tons, while maximum range dropped from 9,100 to 8,700 km. Range with maximum load remained unchanged at 4,260 km.

COPYRIGHT: "Zarubezhnoye voyennoye obozreniye", 1989.

Subcaliber Canister Projectiles for the Mk 7 Gun Mount

904Q0001S Moscow ZARUBEZHNOYE VOYENNOYE OBOZRENIYE in Russian No 8, Aug 89 (signed to press 23 Aug 89) p 77

[Article by Capt 1st Rank V. Nikolayev]

[Text] A program is being implemented for modernizing the Mk 7 406-mm turret triple-gun mount of "Iowa"-Class battleships. A subcaliber discarding sabot canister projectile with almost doubled range compared with the standard HE-fragmentation projectile (38 km) is being developed under the program. Its body (diameter 330 mm) contains around 550 Mk 46 HE-fragmentation submunitions, which presently are being used in U.S. Army 155-mm canister projectiles and are intended for

engaging personnel and light armored equipment. The new projectile is to be equipped with the M724 electronic time fuze with manual initiation-time setting. A SADARM canister projectile with precision submunitions for engaging tanks and other armored targets also is being developed.

To improve the above projectiles' accuracy, the possibility is being studied of creating a new fuze capable of accurately determining projectile muzzle velocity by measuring its rotation frequency at the gun's muzzle face. It is believed that this will permit correcting the set time for burster charge detonation with consideration of fluctuations from mean muzzle velocity, which are one of the essential reasons affecting cumulative error when firing canister rounds.

COPYRIGHT: "Zarubezhnoye voyennoye obozreniye", 1989.

New Aircraft for the French Navy

904Q0001T Moscow ZARUBEZHNOYE
VOYENNOYE OBOZRENIYE in Russian
No 8, Aug 89 (signed to press 23 Aug 89) p 78

[Article by Capt 3d Rank A. Gladkov]

[Text] The French government decided to create a variant of the Rafale aircraft as a new combat aircraft for the country's Navy. This was stated by Prime Minister M. Rocard during a visit to the French Mont-de-Marsan Air Force Base in November 1988.

The question of producing a new combat aircraft for the Navy (ACM—Avion de Combat Marine—Program) remained opened for a long time. The fact is that replacement of obsolete Crusader aircraft aboard the carriers "Clemenceau" and "Foch" was planned up to 1993, while the first Rafale fighters were to become operational only in 1996. The American F/A-18 Hornet fighter was considered as an intermediate option. The fact that the number of Rafale aircraft needed for the Navy (30 at first and 86 over the next 15-18 years) would have cost almost 1.5 times higher than the very same number of American aircraft was in the Hornet's favor. The Navy command was inclined to decide to purchase the F/A-18 Hornet. The carrier "Clemenceau" was fitted with elevators designed for this aircraft and it was also planned to conduct a series of test flights from the carrier, but these plans caused violent protest on the part of interested French industrial circles, particularly the firm of Dassault-Breguet.

In April 1988 the French Ministry of Defense signed two agreements opening the way for realization of the ACM program: with the firm of Dassault-Breguet and with SNECMA, which will create the M88 engine for the aircraft (its first tests are expected in 1989).

The clients are placing very high demands on the future aircraft. It must be multipurpose, i.e., capable of accomplishing missions typical of deck-based aircraft—

intercepting and attacking both naval and ground targets, for which it must have high speed, maneuverability and sufficiently large load-carrying capacity. It is proposed to arm the aircraft with two built-in DEFA-554 30-mm guns, laser-guided aerial bombs, and the Matra air-to-air missile on 12 external hardpoints, six of which are under the fuselage. Special attention is being given to creating modern radar equipment. For example, the radar must support surveillance of the situation in the air and on the sea surface, tracking up to eight targets simultaneously. It is proposed to use monolithic integrated circuits operating in the millimeter and microwave bands to create it. It is planned to present the first two prototypes of the Rafale-B aircraft for flight tests by the end of 1991.

COPYRIGHT: "Zarubezhnoye voyennoye obozreniye", 1989.

Articles Not Translated from ZARUBEZHNOYE VOYENNOYE OBOZRENIYE No 8, August 1989

904Q0001U Moscow ZARUBEZHNOYE
VOYENNOYE OBOZRENIYE in Russian
No 8, Aug 89 (signed to press 23 Aug 89) pp 1-2

[Text]

- New Appointments in the Greek Armed Forces
(I. Monastirev)p 16
- Identification Symbols, Painting and Marking of
French Air Force Aircraft and Helicopters
(S. Sakharov)pp 41-44
- Swedish Portable Mine Detector
(N. Zhukov)pp 76-77
- New Japanese Defense Agency Chief
(Unattributed)p 78
- Foreign Military Chronicle
(Unattributed)pp 79-80
- Meeting with Red Banner Odessa Military District Per-
sonnel (Unattributed)p 80
- Color inserts: Crossing a Water Obstacle Using a
Floating Bridge of the Ribbon Bridge Train/U.S. C-141B
Starlifter Strategic Military Transport Aircraft/French
Mirage-2000 Fighter-Interceptor/U.S. V-22 Osprey Air-
craft (Unattributed)pp 48-49

COPYRIGHT: "Zarubezhnoye voyennoye obozreniye", 1989.

Publication Data

904Q0001V Moscow ZARUBEZHNOYE
VOYENNOYE OBOZRENIYE in Russian
No 8, Aug 89 (signed to press 23 Aug 89)

[Text] English title: FOREIGN MILITARY REVIEW

Russian title: ZARUBEZHNOYE VOYENNOYE
OBOZRENIYE

Editor: V. I. Kozhemyakin

Publishing house: Izdatelstvo "Krasnaya zvezda"

Place of publication: Moscow

Date of publication: August 1989

Signed to press: 23 August 1989

COPYRIGHT: "Zarubezhnoye voyennoye obozreniye",
1989.

10

This is a U.S. Government publication. Its contents in no way represent the policies, views, or attitudes of the U.S. Government. Users of this publication may cite FBIS or JPRS provided they do so in a manner clearly identifying them as the secondary source.

Foreign Broadcast Information Service (FBIS) and Joint Publications Research Service (JPRS) publications contain political, economic, military, and sociological news, commentary, and other information, as well as scientific and technical data and reports. All information has been obtained from foreign radio and television broadcasts, news agency transmissions, newspapers, books, and periodicals. Items generally are processed from the first or best available source; it should not be inferred that they have been disseminated only in the medium, in the language, or to the area indicated. Items from foreign language sources are translated; those from English-language sources are transcribed, with personal and place names rendered in accordance with FBIS transliteration style.

Headlines, editorial reports, and material enclosed in brackets [] are supplied by FBIS/JPRS. Processing indicators such as [Text] or [Excerpts] in the first line of each item indicate how the information was processed from the original. Unfamiliar names rendered phonetically are enclosed in parentheses. Words or names preceded by a question mark and enclosed in parentheses were not clear from the original source but have been supplied as appropriate to the context. Other unattributed parenthetical notes within the body of an item originate with the source. Times within items are as given by the source. Passages in boldface or italics are as published.

SUBSCRIPTION/PROCUREMENT INFORMATION

The FBIS DAILY REPORT contains current news and information and is published Monday through Friday in eight volumes: China, East Europe, Soviet Union, East Asia, Near East & South Asia, Sub-Saharan Africa, Latin America, and West Europe. Supplements to the DAILY REPORTS may also be available periodically and will be distributed to regular DAILY REPORT subscribers. JPRS publications, which include approximately 50 regional, worldwide, and topical reports, generally contain less time-sensitive information and are published periodically.

Current DAILY REPORTS and JPRS publications are listed in *Government Reports Announcements* issued semimonthly by the National Technical Information Service (NTIS), 5285 Port Royal Road, Springfield, Virginia 22161 and the *Monthly Catalog of U.S. Government Publications* issued by the Superintendent of Documents, U.S. Government Printing Office, Washington, D.C. 20402.

The public may subscribe to either hardcover or microfiche versions of the DAILY REPORTS and JPRS publications through NTIS at the above address or by calling (703) 487-4630. Subscription rates will be

provided by NTIS upon request. Subscriptions are available outside the United States from NTIS or appointed foreign dealers. New subscribers should expect a 30-day delay in receipt of the first issue.

U.S. Government offices may obtain subscriptions to the DAILY REPORTS or JPRS publications (hardcover or microfiche) at no charge through their sponsoring organizations. For additional information or assistance, call FBIS, (202) 338-6735, or write to P.O. Box 2604, Washington, D.C. 20013. Department of Defense consumers are required to submit requests through appropriate command validation channels to DIA, RTS-2C, Washington, D.C. 20301. (Telephone: (202) 373-3771, Autovon: 243-3771.)

Back issues or single copies of the DAILY REPORTS and JPRS publications are not available. Both the DAILY REPORTS and the JPRS publications are on file for public reference at the Library of Congress and at many Federal Depository Libraries. Reference copies may also be seen at many public and university libraries throughout the United States.