

JPRS-EST-90-001  
3 JANUARY 1990

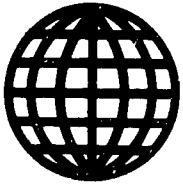

**FOREIGN  
BROADCAST  
INFORMATION  
SERVICE**

# ***JPRS Report***

**DISTRIBUTION STATEMENT A**  
Approved for public release  
Dissemination Unlimited

# **Science & Technology**

***Europe***

**DIC QUALITY INSPECTED 3**

REPRODUCED BY  
U.S. DEPARTMENT OF COMMERCE  
NATIONAL TECHNICAL INFORMATION SERVICE  
SPRINGFIELD, VA. 22161

**19980123 085**

# Science & Technology Europe

JPRS-EST-90-001

CONTENTS

3 JANUARY 1990

## WEST EUROPE

### AEROSPACE, CIVIL AVIATION

- ESA President on European Participation in Columbus Project  
[Egon Schmidt; Stuttgart VDI NACHRICHTEN, 27 Oct 89] ..... 1
- Columbus Project Management Software Developed  
[Thomas Wiegold; Stuttgart VDI NACHRICHTEN, 20 Oct 89] ..... 2
- Eutelsat II on Target for April Launch  
[Paris LA LETTRE HEBDOMADAIRE DU GIFAS, 19 Oct 89] ..... 3
- France: CNES Reorganization Described [Paris AFP SCIENCES, 21 September 89] ..... 3
- Vulcain Engine Combustion Chamber Tested  
[Gunter Paul; Frankfurt/Main FRANKFURTER ALLGEMEINE ZEITUNG, 21 Sep 89] ..... 6

### COMPUTERS

- New Olivetti Computer To Be Marketed in West [Rome LA REPUBBLICA, 20 Oct 89] ..... 7

### MICROELECTRONICS

- FRG Reporting on JESSI Projects, Funding ..... 7
- Goals Outlined [Wolfgang Mock; Stuttgart VDI NACHRICHTEN, 27 Oct 89] ..... 7
- Interview With Chairman Krijgsman  
[Wolfgang Mock, Rudolf Schulze; Stuttgart VDI NACHRICHTEN, 27 Oct 89] ..... 9
- User Concerns Discussed [Rainer Hofmann; Stuttgart VDI NACHRICHTEN, 27 Oct 89] .... 10
- Laender Compete for Funds  
[Wolfgang Mock; Stuttgart VDI NACHRICHTEN, 27 Oct 89] ..... 11
- FRG: Siemens-AEG Joint Venture for High-Power Components  
[Paris AFP SCIENCES, 26 Oct 89] ..... 12
- France: Thomson To Build Flat Panel Display Factory [Paris AFP SCIENCES, 26 Oct 89] ..... 12

## EAST EUROPE

### COMPUTERS

- GDR's Strategy for Interconnecting UNIX-Compatible Computers  
[Detlef Gierth, Uwe Inhoff; East Berlin MIKROPROZESSORTECHNIK Aug 89] ..... 14
- Hungarian Central Physics Institute's Computer Net Described  
[Timea Tiborc; Budapest COMPUTERWORLD/SZAMITASTECHNIKA, 16 Sep 89] ..... 18

### FACTORY AUTOMATION, ROBOTICS

- Hungarian Joint Venture To Use CAD/CAM in Plastics Industry  
[Budapest COMPUTERWORLD/SZAMITASTECHNIKA, 16 Sep 89] ..... 20
- Computer-Controlled Insertion Device for Circuit Boards Described  
L. Hempel; East Berlin NACHRICHTENTECHNIK-ELEKTRONIK, No 9, 1989 ..... 20
- Microelectronics Component Symposium Exhibits New Products  
[East Berlin MIKROPROZESSORTECHNIK, No 10, Oct 89] ..... 21
- GDR's PCM 30-400/800 Radio Relay System Described  
[Egbert Rempt; East Berlin NACHRICHTENTECHNIK-ELEKTRONIK, Oct 89] ..... 23

### TELECOMMUNICATIONS R&D

- Analog Transmission Systems of Czechoslovak Telecommunications Network Described  
[Miroslav Komarek; Prague TELEKOMUNIKACE, Sep 89] ..... 29

## AEROSPACE, CIVIL AVIATION

### ESA President on European Participation in Columbus Project

90CW0049B Stuttgart VDI NACHRICHTEN in German 27 Oct 89 p 30

[Article by Egon Schmidt: "The Self-Confidence of the Old Continent Is Growing—Project Columbus: If Necessary Will Europe Go It Alone? ESA President Reimar Luest Calls Upon the United States To Fulfill Its Space Station Contracts"]

[Text] While the Europeans with their space efforts were only front-seat passengers of the all-powerful NASA organization for decades, the situation has since completely changed: Since the Ariane rockets are flying into the heavens quite reliably, there is no longer the sentiment to take everything that Big Brother dishes out. Instead, in view of the current debate in the United States regarding the curtailment of funds for the international Columbus Space Station, there is a call for the Americans to fulfill their contractual obligations or Europe would go it alone.

The new self-confidence among European spaceflight managers became more discernible as Prof Reimar Luest, the director general of the European Space Agency, spoke to journalists in Munich on the project of the European Space Lab Columbus, for the installation, manning, and operation of which it was planned to utilize American space shuttles. He said: "The United States is currently—once more—having budget problems with respect to Project Columbus, although it is incontestable that they have undertaken clear contractual obligations." And these obligations should now be "meticulously adhered to," as is expected by the Europeans who, according to Luest, are also clearly saying now: "If push comes to shove, we will manage it ourselves."

When pressed by VDI NACHRICHTEN, Luest elaborated, at the end of his Munich press conference, that the Europeans could, meanwhile, "acquire and operate manned space stations" even without the United States and that the independence of the Old Continent in fact already went so far that it is "no longer dependent upon the United States even in the field of microelectronics." Overall, Luest continued, "the atmosphere in dealing with the Americans has clearly changed," since "our Ariane rockets are flying with reliability"; and the self-confidence of the Europeans, who have long been operating in mixed ESA engineering teams in a manner which transcends borders and nationality problems, is increasing more and more.

With respect to the actual status of ESA activities, Luest said, among other things, that "we have just received the bids of industry for the Columbus Project; the Hermes space glider as a potential transport facility for crew members is "still in an early stage of discussion." At the launch complex in Kourou, South America, the work on a new launch complex for Ariane V rockets, as well as for the Hermes space glider is said to be in full swing and it will be

possible to crown this DM 1 billion project as early as 1991-1992 with the construction of launch facilities.

Also, according to Luest, the work on the Ariane V rocket itself is said to be making "satisfactory progress," with the development of this Ariane project alone currently employing some 3,000 engineers and technicians.

The Munich press conference was a welcome occasion for the scientist Luest and former chief of the Max Planck Society to underscore the high level of German science: Whereas the German share in scientific or research experiments "was zero in the beginning," German scientific institutions are "now partially almost 50-percent participants in individual satellite experiments." This "by far" exceeds the German share in the financing of ESA, with its 25-percent share, and this fact was primarily an indicator of good quality since scientific experiments are always "only accepted in the programs on the basis of their scientific quality and not in accordance with the customary country ratio."

As far as the bulk of ESA funds is concerned, the "backflow of funds to German industry has been at a level of around DM 2 million greater, cumulatively," than the amount of funds which Bonn has transferred to Paris in the same time frame. What is interesting in this connection is that the ESA countries are contractually guaranteed a fund backflow of at least 95 percent of their payments and that Professor Luest feels "at least a little" restricted by this guarantee, as he says. Fears that this 95-percent limit could perhaps affect the quality of the offerings or the developments and, thus, the finished systems are decisively rejected by him: After all, the orders of the ESA are channeled to individual general contractors "who, for their part, again contract with subcontractors" and who then, "although they must bear the country quotas in mind, make priority decisions from the standpoint of quality."

That the uncertain relationship with the U.S. partner appears to be occupying ESA officials more than they would like to admit was clearly indicated by statements such as the one by a Bonn ministerial official that the current NASA budget quarrels regarding Project Columbus have "now caused a question mark to appear in the relationship with our American partners." And Luest stated again that "cooperation with the United States was actually a very significant factor with regard to Columbus"; one had built firmly upon American contractual fidelity—and "now it seems, after only a year, there are already serious problems with contract fulfillment." This could have consequences which "could be very far-reaching, primarily as a result of their psychological importance."

Yet everything is far from lost: examples of good cooperation across the Atlantic can be found today as before—even if they are "only" a type of reversed assistance. While the Americans have currently lost a weather satellite, Europe is "lending" them one of its own for around 9 months.

### Columbus Project Management Software Developed

90CW0049A Stuttgart VDI NACHRICHTEN in  
German 20 Oct 89 p 31

[Article by Thomas Wiegold: "With Artemis Into Space—Software Holds Large Project in Its Grip—Management System Coordinates Activities of 140 Firms"]

[Text] Space Station Columbus, a major project of the European Space Agency [ESA] costing more than DM 5 billion, is to receive electronic management support. It is worth DM 12 million to the Europeans to keep the giant project with its flood of data on development, planning, deadlines, and costs under control with the specially developed Columbus Project Management System [CPMS].

In a former tobacco company building in an industrial region of the city of Bremen, graduate marine scientist and project control specialist Claus Krummrey directs a 20-member design team which is supposed to fashion the CPMS into a user-friendly tool for approximately 140 firms from 13 European countries which are tied to the Columbus Project with approximately 400 individual contracts. Krummrey's employer, the MBB affiliate Erno Spaceflight Equipment Co., is not only the principal contractor for the space station on behalf of the European Space Agency, but also plays a role as leading company in the industrial consortium vis-a-vis the numerous co-contractors and subcontractors. It is thus responsible for directing and monitoring the content, the deadlines, and the costs for the space project. Adhering to these criteria is the supreme goal of this ambitious project.

Since spaceflight is not only expensive, but the overall project is mammoth in size and the individual components are almost not visible at a glance, the European Space Agency paid attention to effective control from the beginning. The European space planners prescribed the software for the project management system contractually. From a small part delivered by a subcontractor through the "autonomous free-flight platform," one of the principal components of the Columbus Project, CPMS is to maintain control over deadlines and planning, provide an overview of costs, and tie the changes which are almost bound to occur in a project of this magnitude into the overall planning.

For this purpose, the European Space Agency prescribed the Artemis data bank system as a basis, as well as a project management application developed in the United States—a system which is already being applied in the economy. Naturally, it had to be modified for use in Europe and the plans of the Europeans. "The ESA has requirements which differ, for example, from those of the U.S. Department of Defense," says Krummrey. According to the wishes of the civilian space agency, the standards were newly formulated. Basically new applications were developed for use on personal computers available at subcontractor locations which are also expected to perform individual fabrication steps for the Columbus Project.

Krummrey says that "because of the large number of contracts, we had to standardize the system." The CPMS, in the configuration in which it is to be used on up to 10 to 11 mainframes and a multiplicity of personal computers, is made up of 3 components: the "Project Control Subsystem," which encompasses the actual planning, deadlines, and costs, the "Financial Control" component, and, finally, the "Change Control" component which handles changes during the life of the project, determines the effect of these changes on the work, and delivers the data necessary for changes in contracts.

Just like Columbus is to become a child of Europe, the "Financial Control" component of the project management software system is adapted to the requirements of the Old Continent. Here, it is not enough to only control costs. Every country which, like the Federal Republic of Germany with its lion's share of 38 percent, makes a contribution to the space station must also be appropriately considered during the distribution of subcontracts proportionate to its participation. This "geographic control," as well as the acquisition of the necessary funds in the proper currencies and at the right time, is a European specialty which the programs in the United States do not need to this extent.

"Change Control" will also be adequately utilized: in the approximately 10 years before the end of the project, members of the project management team anticipate some 4,000 change orders. During this time span, the technical data and requirements can, after all, change—and thus cause changes in entire components of planning, even if all previously stipulated deadlines and costs are adhered to. Krummrey clarifies the problem by saying "if the necessity arises, we must process every changed screw thread fastener. This is why spaceflight is also so expensive."

The reporting structure which is utilized in the CPMS adheres closely to conventional methods. Each month, at a predetermined date, the participating enterprises report the cost situation and deadline situation for their portion of the contract in a standardized manner to the English-language matrix of the system. These reports are passed on and compiled through five to six levels from the smallest subcontractor upward to the MBB/Erno Enterprise, the developmental status and fabrication status of entire modules and aggregates is fed into the system and passed on by modem from level to level. Ten to fifteen days after the reporting period at the lowest level, the data, which represent a compilation of all work steps in the project, drop out, after having been pretested and commented on, at the location of the principal contractor in Bremen.

### Principal Advantage Is Better Quality of Data

Claus Krummrey, in discussing the principal advantage of the electronically supported project management system, says that "with existing methods the time lag would be about the same. But the quality of the data would be lower." Instead of receiving endless stacks of

paper and tables, which contain every detail, the specialists at the top of the contractor pyramid receive summarized information which keeps them up-to-date regarding essential developments. Armed with this information, they can "recognize deviations from the norm, but do not get lost in the mass of detail," is the explanation of the difference provided by the project manager.

The project management system does not render superfluous a single one of the experts who must draw their conclusions from the delivered data. Krummrey warns: "I see such a tool providing neither a significant time advantage nor leading to the reduction of manpower." Yet he says that the quality of the data and its presentation increases the reliability with which specialists can react when something goes wrong—even though the data flow at first takes as long as it did previously, when tables were checked and deadline plans largely had to be compared manually.

But the very "throughplay" of changes in deadline planning makes the CPMS into a lightning-fast affair. Various target dates, for example, the planned delivery of a component, can be tied in with other target dates. If one phase of the work takes longer—"and it always takes longer, it never takes less time," says a CPMS project employee—the delayed start is automatically factored into the other step which also indicates the other delays connected with it.

#### Planning Reaches Far Into the Future

Krummrey explains: "Our goal with CPMS is not only to capture the current status, but to look far into the future. The so-called work packet managers, who are responsible for individual sectors of the project, are supposed to be able to use the tool for planning into the future—to see whether a specific problem in individual sectors might make new planning necessary, whether contracts need to be altered with the aid of "Change Control," whether new funds must be acquired, whether materials or manpower must be distributed in a different manner.

Lastly, Krummrey admits that the question as to whether computerized project management can satisfactorily fulfill all desired tasks cannot be answered with finality until conclusion of the project. Yet the CPMS is also a touchstone for the large standardized project management systems which transcend borders and are used by a multiplicity of enterprises. "There is no large-scale project yet which has advanced this far with a standard system," says Krummrey. Meanwhile, the ESA is said to be planning CPMS for all its major projects or is planning to apply a similar version of the Artemis system.

He who makes decisions, says: the costs of CPMS are borne by the European Space Agency. Even without the developmental work which is currently still ongoing at MBB/Erno, the software alone costs DM 500,000 per mainframe computer and an additional DM 1 million for the PC development. By the time the system, with all its individual components, is ready for use with each of the participating enterprises, the cost will include an

additional 15 man-years of developmental work. Krummrey estimates that a total of DM 12 million of the total cost of the Columbus Project will be required for CPMS.

It is expected that the enterprises will make their own computer hardware available for this project. Krummrey says: "If you open a garage, you cannot let the customers pay for the tools."

#### Eutelsat II on Target for April Launch

90AN0058 Paris LA LETTRE HEBDOMADAIRE DU GIFAS in English No 1496-1, 19 Oct 89 p 2

[Article: "Aerospatiale Presents First 'Eutelsat II' Satellite"]

[Text] The first Eutelsat II satellite is at the final stages at the Aerospatiale Cannes premises. It is a second-generation satellite built on behalf of Organisation Europeenne de Telecommunication par Satellite. Starting in 1990, the Eutelsat II will supply telecommunications functions including data transmission, business connections, telephone service, TV, and radio broadcasting for 26 countries, from Iceland to Turkey. The Eutelsat II, designed and built by Aerospatiale, is a satellite of the "Spacebus 100 type", 3-axis stabilized and having a weight of 985 kgs on geostationary orbit. Payload consists of 16 relays of the 50 Watt ku band type. Launching is scheduled for April 1990 by means of the Ariane flight V-38. Eutelsat has so far ordered five satellites worth 340 million European monetary units, and taken three options. Delivery of the first satellite ordered in May 1986, exactly on schedule, is a tribute to the European team that builds it, under prime contractorship of Aerospatiale. Other members of the team include Aeritalia (Italy), Alcatel Espace (France), Marconi Space System (UK), CASA (Spain), Ericsson Radio Systems (Sweden), ETCA (Belgium), MBB (Germany), and Crouzet (France).

#### France: CNES Reorganization Described

90CW0045c Paris AFP SCIENCES in French 21 September 1989 p 11

[Article entitled: "The CNES Reorganizes: More Efficient and More European"]

[Text] It was a National Space Studies Center (CNES) revamped to make it more efficient, more focused on technologies of the future, and more European that Mssrs Jacques-Louis Lions and Jean-Marie Luton, its president and general director, presented on 14 September.

With a government subsidy of 7,187 billion French francs, compared to 6,453 last year, to cover its program authorizations and ordinary expenses, the CNES "is a happy organization." It has a staff of 2,357 and, its officials said, is aware of the importance of its work, its European character, and the need to constantly assimilate findings

from all scientific disciplines in order to continue preparing its current programs and sketch out those of tomorrow.

"The changes in the CNES are taking place in an atmosphere of continuity. The organization has three priorities: to pursue technological ambitions, act as a linchpin in environmental studies, and continue its work to put man and robots in space together," observes Mr Lions.

The nomination of General-Cosmonaut Jean-Loup Chretien as presidential advisor for manned flights confirms the organization's commitment in that area. "We are pursuing negotiations for the third flight of a French cosmonaut aboard Soviet stations in 1992. It will last 14 days, 12 of which will be spent aboard one of them," says Mr Lions.

"The new [organizational] structure will be efficient through the end of the century," stresses Mr Luton. He will be assisted by Mr Jean-Jacques Sussel, assistant general director in charge of research and applications (who will retain his title as director of the Toulouse Space Center) and Mr Daniel Sacotte, assistant general director in charge of strategy, planning and international (particularly European) and industrial affairs. Mr Alain Simon will be responsible for the central technical office, while Mr Issac Revah will take charge of the "Environment" program under Mr Luton.

Mr Revah's job will be to internationally coordinate the environmental work to be done, for every country is now convinced that the Earth's environment must be studied globally.

#### **Hermes Performance Satisfactory**

Mr Roger Vignelles, assistant general director for space transport systems since April, said he is confident of the

success of work done in the Ariane-5 and Hermes programs.

"We are moving along at economic speed on Ariane-5. The first flight will take place in 1995, the first operational flight the following year," said Mr Vignelles. "A Vulcan engine will be totally assembled in November for tests in mid-1990 on the PF-50 test bench being built at SEP (European Propulsion Company) in Vernon (Eure). In Kourou, construction of the ELA-3 launch pad and ground infrastructures are continuing."

"As far as Hermes is concerned, all the experts will undoubtedly be convinced by the end of the year that it can be done without exceeding costs and time limits and without compromising the safety of its 3-man crew for flights to American (Freedom) or Soviet (Mir) stations or autonomous missions. There is still much to be done, but results [of work] on thermal-shield tiles, insulation, aerodynamics, etc. are already satisfactory," Mr Vignelles continued.

The CNES will continue to cooperate scientifically within the framework of the European Space Agency (ESA) or bilaterally with the United States and the USSR in fields as diverse as in the past (biology and space medicine, observation of the Earth, oceanography, astronomy, etc.). It will continue research or follow-up of programs such as Telecom-1 and -2, TDF-1, Olympus (telecommunications or live television), Argos, Locstar, Cospas-Sarsat (tracking and recovery), or Earth observation (such as Spot).

The CNES has financial interests in 8 industrial firms which had sales of 4,042 million French francs in 1988, 3,672 million generated by Arianespace alone, pointed out Mr Luton.

CNES Organizational Chart As Of September 1989

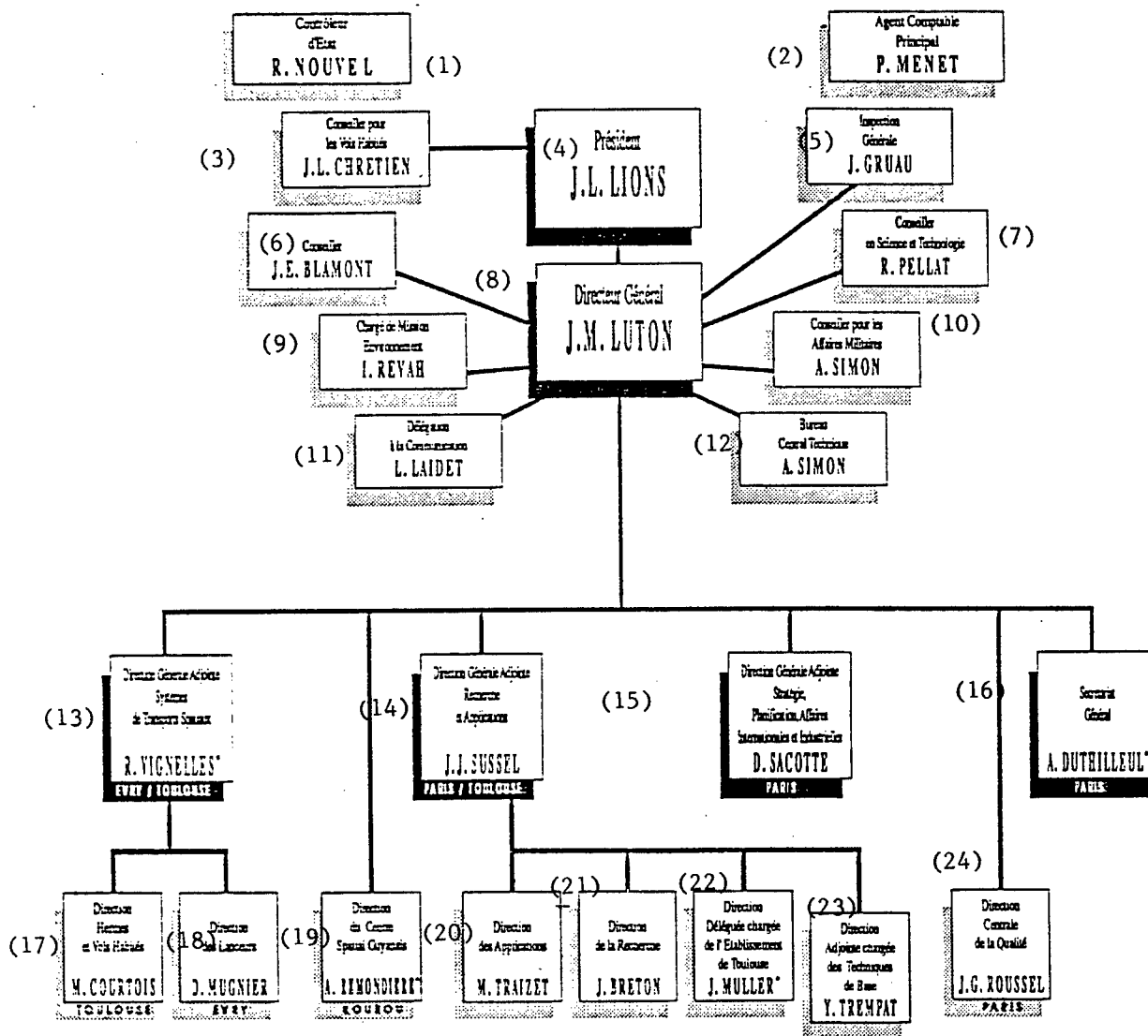

\* CHEFS D'ETABLISSEMENT

Key:

- 1. State Controller
- 2. Principal Accountant
- 3. Manned Flight Advisor
- 4. President
- 5. General Inspection
- 6. Advisor
- 7. Science and Technology Advisor
- 8. General Director
- 9. Environmental Program
- 10. Advisor for Military Affairs
- 11. Communications Delegation
- 12. Central Technical Office

\*Organizational Heads

- 13. Assistant General Director, Space Transport Systems
- 14. Assistant General Director, Research and Applications
- 15. Assistant General Director, Strategy, Planning, and International and Industrial Affairs
- 16. General Secretary
- 17. Director, Hermes and Manned Flights
- 18. Director of Launchers
- 19. Director of Guyana Space Center
- 20. Director of Applications
- 21. Director of Research
- 22. Director, Delegate in Charge of Toulouse Center
- 23. Assistant Director in Charge of Basic Techniques
- 24. Director of Central Quality Control

### Vulcain Engine Combustion Chamber Tested

90CW0007A Frankfurt/Main FRANKFURTER  
ALLGEMEINE ZEITUNG in German 21 Sep 89 p 11

[Article by Gunter Paul: "Largest Rocket Engine Ever Built in Western Europe, Thrust of One Hundred Tons, Into Space in 1995"]

[Text] Lampoldshausen, 20 September. All at once, a violent rumbling builds up in the hall, as loud as the noise from a street construction site. The ground also begins to vibrate slightly. A long red flame, shooting from the test stand, appears on the large screen. This is the ignition of the Ariane engine, or more precisely, the combustion chamber of the main engine. It was designed to carry the Ariane 5 into space for the first time in 1995.

Tests are being run for the future on the grounds of the German Aerospace Establishment (DLR), near the small city of Lampoldshausen in Baden-Wurtemberg. The combustion-chamber test lasts seventeen seconds. The combustion chamber is the heart of the Vulcain engine, the largest rocket engine ever built in Western Europe. Minutes before, the loudspeakers announced that no one was to leave the bunkers on the grounds. Remaining in the open was now prohibited. These instructions have to do with general safety but also with the loud noise generated during the trial. At the test stand, this noise increases up to one hundred-fifty decibels. The pain threshold is one hundred-twenty decibels.

The European Space Agency (ESA) has been exactly on schedule with the development of Ariane 5 thus far. Scarcely noticed by the public, the project already employs three thousand people—in industry and for the authorities—on the continent. The ESA has already spent two billion marks for the rocket. Of this amount, four hundred million marks have gone to the Federal Republic. Among other projects, the money was used to build the test stand operated by Messerschmitt-Boelkow-Blohm (MBB). This test stand is the only one in Europe that can test engines having thrusts up to one hundred-fifty tons and combustion-chamber pressures up to 150 atmospheres.

The test stand started operation this past December. Since that time, the combustion chamber of the Vulcain engine has undergone about twenty tests. Some of these trials have also used the nozzle through which the hot reaction gases exit the rocket engine. When burning liquid hydrogen and liquid oxygen, the inside of the combustion chamber reaches a temperature of about 3500 degrees. The flame deflector directs the gases shooting out horizontally from the combustion chamber on the test stand upward. The seventeen seconds of the trial heat it to 1000 degrees. In spite of constant water cooling during the test, it is still not advisable to touch the deflector even three-quarters of an hour later. By that time, it has only cooled down to ninety-five degrees.

If one day the powerful Ariane 5 is able to lift off from Kourou (French Guiana) into space, this will be primarily thanks to the Ariane's high-performance drive system. The central Vulcain engine and two additional solid-fuel engines propel the main stage of the rocket. The Vulcain engine alone has a thrust of 100 tons and is ten times as powerful as the HM 7 engine. MBB constructed this combustion chamber for the smaller Ariane rockets. One hundred tons of thrust mean that the device can balance a load of one hundred tons. To do this requires large amounts of fuel. The trial in Lampoldshausen uses one thousand liters of liquid hydrogen each second, the demand for liquid oxygen was less. The hydrogen industry is profiting from this development. Nowhere else in Europe (except for the French city of Vernon) is so much liquid hydrogen needed as in Lampoldshausen. As a result of the great demand, the price of liquid hydrogen has dropped in the past fifteen years from fifteen to three marks per liter.

Plans call for about two hundred test stand trials within the Vulcain engine (previously known as the HM 60) until 1993. The first complete test is to take place this July on a new, large test stand of the DLR in Lampoldshausen. At that time, the combustion chamber and the nozzle will be united with the fuel pumps. The fuel pumps carry the fuel into the combustion chamber. The mixture of hydrogen and oxygen burns in the combustion chamber making hot gases. The nozzle ejects these reaction gases outward at high speed.

The ESA has planned two test flights of the Ariane 5 for 1995. In 1998, the rocket is to carry the reusable, manned space shuttle Hermes into space for the first time. Whether this goal will be achieved on schedule is open to question, however. The technicians are still occupied with the design plans for Hermes.

The fate of Columbus, the European contribution to the American space station Freedom, is also unclear. Because the Congress of the United States has reduced the new budget for space travel, NASA has considered reducing the size of the space station. This would mean that the Europeans' free-flying laboratory planned for Freedom would no longer be able to dock. Also, the lower amount of available electricity would ruin several experiments. For the Europeans, who have made firm contracts with the Americans, this would be unacceptable. For them, the Ariane 5, Hermes and Columbus represent a unit. The General Director of the ESA, Reimar Lust, explained this predicament once again to NASA this past week. He also noted that the Europeans would build their own space station independently of the Americans if necessary.

As Lust said now in Lampoldshausen, he got the impression during the discussions that the Americans had finally understood the European point of view. The Administrator of NASA had assured him that the space station would not be downsized to an extent that would affect contractual cooperation with the Europeans. However, it is conceivable that the construction phase for

Columbus could be drawn out by the Europeans. Some member countries of ESA want to lighten the burden of their annual space-travel budget this way. Because of this, the Ariane 5 may be the only large-scale project of manned space flight in Europe that swiftly proceeds toward its completion.

## COMPUTERS

### **New Olivetti Computer To Be Marketed in West**

*90ES0189B Rome LA REPUBBLICA in Italian  
20 Oct 89 p 47*

[Article by Franco Papitto: "And Now Olivetti Is Launching the Computer "Platform""]

[Text] Vittorio Cassoni, managing director of the Olivetti group talks about a "turning point in the information science industry." He is referring to a new system developed by the Ivrea company and presented yesterday in Brussels to European dealers, before being unloaded in the United States. It is called Cp486, no longer a personal computer but a Computing Platform. And the latter "is the basis for the development of the most varied applications solutions intended for the final user," as Cassoni explains in the somewhat esoteric language of information scientists. Cassoni says, "The Cp486 can in fact be used, according to its configuration, as a very powerful personal computer, as a network server, as a departmental computer, and as a technical workstation."

People did not fail to ask—in Italian, and in a hall where English served as unchallenged master—about the possible sale of the Cp486 in Eastern European countries. Cassoni replied that the priority market was Western Europe, destined in the coming years to have high rates of expansion in order to catch up on its delay vis a vis the United States. The Cp486 is looking toward another market, the American market, where Olivetti is already firmly established. Cassoni said that while attention will one day be turned to Eastern Europe, "It will be done with full respect for the rules, and with all needed approvals, as has always been done in the past."

The Computing Platform is intended to be a meeting ground between the past and the future. It is a "universal hardware and software platform arising from the convergence of innovative technology and industrial standards, and it constitutes the basis for development of the most varied applications capable of taking advantage of growing hardware power and a very wide supply of software." For Vittorio Cassoni, the Cp486 "brings together Olivetti experience in the sector of personal computers and minicomputers, offering definitive leading technology. This experience in planning and sales makes Olivetti one of the few world suppliers able to present to the market the new concept of the "Computing Platform."

The Cp486 is a product of broad international cooperation. The managing director of the Olivetti group said, "Our strategic relations with Intel, Microsoft, and Sco, together with the ability of our project group based in California and our participation in the Eisa consortium, has allowed us to make this product available ahead of the most qualified competitors." The new computer was planned in the Olivetti laboratories of Cupertino, in California, and is produced in the Scarmagno plants in Ivrea. It is one of the first systems to make use of the internal architecture defined by the world consortium, Eisa, which comprises nine of the largest constructors of information systems. Olivetti is the only European company which has been present in the consortium ever since its founding. Thanks to the integrated circuits specially planned by Intel, Eisa architecture incorporated in the new computer considerably increases the global performance of the system, doubling the speed of the preceding ISA standard which, with more than 20 million machines installed, is the most widely used standard at the world level.

Luigi Mercurio, in charge of Olivetti Systems and Networks, the group's plant which operates in the information distribution sector and which designed the new Cp486, emphasized the importance of the new system within the context of Olivetti products. Mercurio said, "The Cp486 is added to our line of solutions destined for the most dynamic market, that of high performance systems for departmental information distribution. The Cp486 will be progressively integrated into the Olivetti Open System Architecture (OSA), ensuring our users of the adoption of new technologies and protecting their software investments." The new system will provide total compatibility with MS-DOS, and MS-OS/2, and Unix System V software. In particular, the entire library of software applications already developed for the series 386 personal computers can be immediately used on the Cp486.

## MICROELECTRONICS

### **FRG Reporting on JESSI Projects, Funding**

#### **Goals Outlined**

*90CW0040A Stuttgart VDI NACHRICHTEN in  
German 27 Oct 89 p 4*

[Article by Wolfgang Mock: "Crash Course for European Chip Industry"; first two paragraphs are VDI NACHRICHTEN introduction]

[Text]

### **JESSI: A Trump Card in the Microelectronics Poker Game—A Choice Between Going It Alone and Transatlantic Cooperation.**

In a joint effort of industry and politics, the five leading European economies intend to develop the technology

for the 64-mbit chip. With a total outlay of almost DM8 billion, they intend to reach that goal by 1996.

According to FRG Federal Ministry for Research wording of the strategic objective of the program, "JESSI should guarantee European independence in the economically significant key technology of microelectronics, keep valuable systems knowledge in Europe, and thus strengthen the innovative capacity of Europe's industrial economic power."

At first, JESSI (Joint European Submicron Silicon) was supported primarily by the two large European firms, both of which already have 4-mbit technology: Philips from the Netherlands and Siemens AG from the FRG. In the years following 1980, both had obviously already been thinking about the post 4-mbit chip period and thus conceived the basic idea for JESSI. Then, after a few quarrels, in the summer of 1988, the French-Italian company SGS-Thomson was accepted as a third partner on JESSI's steering committee.

Already in the early phase, JESSI was not thought of as merely a program for development of a new chip, but rather as the attempt to fortify the entire microelectronics landscape of Europe—from the technology of chip production to users and manufacturers of devices and hardware all the way to pure research. The American WALL STREET JOURNAL spoke of a "Crash Course for the European Semiconductor Industry."

#### Users Involved in the Project From the Very Beginning

After the European firms and governments involved reached a preliminary agreement, the JESSI planning team began work in Itzehoe at the beginning of 1988 under the leadership of the head of Berlin's Fraunhofer Institute for Microstructure Technology, Anton Heuberger. In February of this year, the first results of the definition phase were presented; then in June, the JESSI project was officially declared a European research project within the framework of the Eureka program (EU 127).

Based on the original ideas, the overall project breaks down into four main areas of emphasis:

- Chip production technology: This involves development of the principles for and testing of flexible, competitive production technology to be available in the mid-1990's for advanced systems applications.
- Application: This targets the designing of flexible, competitive processes and tools usable throughout Europe for development of highly complex integrated circuits and their integration into systems as well as their testing in advanced joint pilot projects from important applicational areas.
- Devices and hardware: This work area is to assure the development of production devices and microelectronics hardware in selected areas of emphasis in the European supplier industry.
- Basic research: In the intermediate term, applications research should assure industrial development of

integrated circuits and their applications with structure sizes down to 0.3 microns. Simultaneously with the reduction in structure width, the wafer will be enlarged from 200 mm<sup>2</sup> to 500 mm<sup>2</sup>.

To date, 29 firms and research facilities are participating in the planning—including from the FRG: Hoechst, BMW, Bosch, AEG, and Nixdorf. The governments of Italy, France, the United Kingdom, the Netherlands, and the FRG promised their support for the Eureka project; and the Brussels EC Commission has joined in as a sixth partner.

When—as planned—the first 64-mbit chips with structure widths of 0.3 microns go into pilot production at the end of 1996, the project will have, according to current estimates, consumed DM7.8 billion and 20,000 man years.

The financing aspect remains unclear. The current calculation assumes that industry will bear 50 percent of the costs, the EC Commission 25 percent, and the participating governments another 25 percent. To date, the only information concerning the amount of their participation has been given by Federal Research Minister Heinz Riesenhuber, who will contribute DM1 billion, and the French government, which is adding a similar amount with Fr 2.9 billion.

The target of the entire JESSI project is Japan—Japan as model and competitor. Each of the three leading Japanese microelectronics firms, NEC, Hitachi, and Toshiba, achieved greater sales with chips alone in 1987 than Siemens, Philips, and SGS combined. In production devices for highly integrated chips, Japan has pushed the U.S. share of the world market from 81 percent in 1978 to less than 40 percent this year, according to the calculations of the American periodical BUSINESS WEEK, and the European share from a previous 9 percent to less than 4 percent.

Under these circumstances, it will not be easy for the Europeans to close the technology gap with Japan. Therefore, negotiations began at the first of this year with IBM-Deutschland concerning cooperation which, according to a representative of the Federal Ministry of Research at the time, "could hardly fail." In fact, for the area of chip device manufacturer, such cooperation makes sense because in the USA, IBM is the driving force behind the Sematech initiative in which the American semiconductor manufacturers are cooperating with production device manufacturers.

#### Investment Costs Double With Each Generation

Conveniently, IBM-Deutschland also informed its European competitors in mid-year in the presence of Chancellor Kohl that IBM now has the current state of the art, 4-mbit technology.

If IBM wants to be accepted as a full JESSI partner, then the extent of Sematech access granted to European firms in exchange also remains to be negotiated, in particular,

the American subsidiary of Philips, Signetics, which has thus far been denied access. To date, the American Senate, which annually supports Sematech with \$200 million in subsidies, has blocked this.

The necessity for European and transatlantic cooperation lies not only in Japan's considerable technological lead but also in escalating investment costs. From one technological generation to the next, on average these double for preseries production alone. With the 1-mbit chip they amounted to DM730 million, with the 4-mbit chip they already reached almost DM1.4 billion, and, according to the BMFT [Federal Ministry for Research and Technology] in its JESSI analysis, "It is not foreseeable that this cost trend will change in the future."

A factory for series production would probably cost at least that much again, in the opinion of experts. Such expenditures cannot be recovered by European chip manufacturers in their domestic markets alone and only with difficulty even on the European market. The same holds for manufacturers of production devices.

However, if JESSI is able to achieve its ambitious goals in the short time frames, the European semiconductor industry could secure a market share of 25 percent worldwide according to Heuberger's estimates.

#### Interview With Chairman Krijgsman

90CW0040B Stuttgart VDI NACHRICHTEN in German 27 Oct 89 p 6

[Interview with JESSI Chairman Cees Krijgsman by Wolfgang Mock and Rudolf Schulze; date and place not given: "What We Need Is a Strong Europe": Large Confederation for Microstructure Technology"; first paragraph is VDI NACHRICHTEN introduction]

[Text] JESSI will improve Europe's education and research infrastructure and provide companies with new technological know-how, according to Cees Krijgsman, who has been chief representative of the first European microelectronics project JESSI for about 3 months. His vision: Approximately 10 years from now Europe should be producing semiconductors equal in value to the total purchased by European industry throughout the world.

VDI-NACHRICHTEN: As newly appointed JESSI chairman you have just completed a long journey throughout Europe. What pledges of funding do you have from governments and the EC Commission?

*Krijgsman:* It is not my job to make agreements with the governments concerning such figures. However, the JESSI planning group is assuming there will be overall financing of DM7.8 billion. Fifty percent of the money is to come from industry, 25 percent from the governments of the five participating countries, and 25 percent from EC funds. We are in the process of specifically defining the individual JESSI projects because most of the governments cannot make financing pledges until specific

projects are ready for decisions. However, at the conference of the Eureka Council of Ministers at the end of June 1989, the governments did declare their willingness to provide financial support.

VDI-NACHRICHTEN: Why is continued development of microelectronics only possible with government assistance? Other branches of industry are managing on their own, aren't they?

*Krijgsman:* In Japan and in the USA the semiconductor sector has always been very heavily supported.

In the USA the Department of Defense has subsidized the entire electronics sector. Virtually 80 percent of microelectronics development there in the 1970's enjoyed government support. That had a tremendous effect on the development of the electronics industry.

In Japan there was the VLSI project in the 1970's. Semiconductor manufacturers and users organized themselves within this framework, but within the same firm for the most part. The results were valuable credits and technical integration.

Given this situation, it becomes difficult for manufacturers who work in a country where they do not have this support. However, when you consider that the remainder of high tech industry is 80 percent dependent on microelectronics, then the pivotal economic significance of the microelectronics industry becomes obvious.

VDI-NACHRICHTEN: When the American semiconductor manufacturers realized that not only were they having to constantly surrender market shares in the international market to the Japanese in some products, but also that even the technological know-how for the production of future products was lacking, they founded Sematech. Is JESSI a competitor for Sematech?

*Krijgsman:* They are not really comparable. Sematech has its own plant in Texas and is supported by shareholders and the Department of Defense.

With JESSI, projects are organized: There is no central laboratory. The work is carried out on the premises of the participating companies and organizations.

In December a Sematech/JESSI work group is meeting for detailed discussions of preliminary proposals for possible cooperation. The determining factor for any cooperation is that it must be based on reciprocity.

VDI-NACHRICHTEN: What chances do small and medium-sized firms have of being able to reap the benefits of the JESSI project?

*Krijgsman:* As a matter of fact, one of the central objectives of JESSI is to introduce small and medium-sized industry to the future challenges of microelectronics. Furthermore, JESSI is creating an infrastructure and training capabilities which can benefit all of industry.

Of course, small and medium-sized firms are not always able to develop the necessary technology because mass production is essential for testing device reliability and assessing economic conditions, but with JESSI, small and medium-sized firms can undertake significant tasks right in the user arena.

Discoveries in the CAD area are, for example, quite significant for all firms.

**VDI-NACHRICHTEN:** The Japanese Ministry of Trade and Industry MITI is a symbol of industrial policy coordinated and organized among the participants. Is JESSI the predecessor of a European MITI?

*Krijgsman:* This comparison is inappropriate because the European mentality itself prevents this. Industry in Europe is too regionally organized. JESSI is a stimulus for European industry, but it does not have the goal of inundating the world with chips.

**VDI-NACHRICHTEN:** What share of the world market will European chip manufacturers be able to attain in 10 years?

*Krijgsman:* I believe that the world needs a strong Europe. And such a strong Europe should have a share of international chip production equal to its demand for chips. This stands today at 34 percent. However, currently, we Europeans have only produced 13 percent of the semiconductors manufactured worldwide.

**VDI-NACHRICHTEN:** And what happens if we Europeans cannot balance the discrepancy between the value of chip production and that of demand?

*Krijgsman:* The imbalance can have long-term consequences for the standard of living of the industrial nations of Europe.

If we continue as we are, it could be possible—in the extreme—that one day we would have to close our technical universities. We must give the talented persons present in Europe an incentive to continue to study physics and engineering and offer them opportunities for work and development.

**VDI-NACHRICHTEN:** In Europe the criticism continues to be heard that JESSI is too late despite all its efforts.

*Krijgsman:* Europe is admittedly quite behind; that's why we have JESSI. We are not, however, lacking in talent. The conviction that we cannot get by without mastering mass production of these chips is gaining increasingly acceptance.

**VDI-NACHRICHTEN:** Is it possible for you to imagine that Europe will fall into protectionism and protect its chip industry through duties as the Americans attempted to do?

*Krijgsman:* : No. We must remain competitive in the marketplace. Japanese wages are actually not so low;

however, we must find new ways to be able to hold our own in competition.

It would help a great deal if our governments would just lend a hand to our developing firms through large orders as the Japanese government has always done.

#### User Concerns Discussed

*90CW0040C Stuttgart VDI NACHRICHTEN in German 27 Oct 89 p 6*

[Article by Rainer Hofmann: "Conflicting Interests of Manufacturers and Small Users"; first two paragraphs are VDI NACHRICHTEN introduction]

[Text]

#### JESSI: Firms Assert Their Influence—Groups of User Firms Are Needed as Middlemen.

Whereas the large chip purchasers work directly with the large semiconductor manufacturers to implement their plans and desires, small and medium-sized customers are left with nothing but the hope of standardization of technology, components, and software. The only chance of success for their desires resides in presenting them through user groups.

Many have high hopes for European technological self sufficiency through the European semiconductor project JESSI. However, the users of tomorrow's microelectronics must also be heard from for development of new products. But, this would require more extensive cooperation of the industry involved and especially of the JESSI partners, according to a recent statement of Karl Friedrich Triebold, CEO of Krupp Atlas Elektronik of Bremen. User specific interests will have to be integrated into JESSI at the appropriate time so that a smooth introduction of developmental results into the user arena may be assured.

The question of who will be able to benefit from the JESSI project as users is not simple to answer. In this, the project area Applications is the most significant based on figures alone: Fully 7,300 of the total 21,400 man years planned are earmarked for the development of applications. The area of Technology ranks second with 6,200 man years.

A glance at the representatives on the management board in the Applications area reveals who consider themselves most likely to benefit: AEG, Alcatel, Bosch, Nixdorf, Olivetti, and Siemens. Dipl.-Eng. Horst Gschwendtner, head of the Integrated Circuit Design Center at Robert Bosch GmbH in Reutlingen, himself a former member of the Applications management board, points to the large systems companies as the primary users.

However, because this does not fully coincide with the ideas of the BMFT, which, in February of this year, made participation in JESSI by small and medium-sized firms a program requirement, Gschwendtner is specifically asking the user groups in the FRG to provide a platform through which their influence can be channeled. The principal groups considered are reportedly

VDA [Association of the Automobile Industry], VDMA [Union of German Mechanical Engineering Works], and ZVEI [Central Association of the Electronics Industry].

Prof. Winfried Rehr, head of the Institute for Applied Microelectronics in Braunschweig, refers in this connection to the already existing position paper developed in cooperation with the BDI [Federal Association of German Industry]. He reports one of the points made very dramatically there, i.e., that the expectations of small and middle-sized firms do not coincide exactly with those of semiconductor manufacturers.

What the small and medium-sized firms hope for from the future is better support of ASIC [application specific integrated circuit] technology. To produce these IC's even in small lots at economic prices should be one of the most important objectives of chip producers and, consequently, of the European JESSI project as well, Rehr emphasized on 18 October in Offenbach at a conference of the VDE/VDI-Microelectronics Association.

"Small and medium-sized firms often think only in 2 or 5 year increments, whereas JESSI actually represents a pre-competitive discussion of products which cannot be produced until 10 or 15 years from now," Behr points out.

Among the desires addressed to semiconductor manufacturers to date in the Applications project area, the most important is the establishment of a modular system of technology on various levels as Horst Gschwendtner reported. The participating chip producers should thus agree to manufacture compatible components, to standardize interfaces, and to develop software which is as manufacturer-independent as possible.

There is apparently no such thing as a typical user. Gschwendtner rejects further influencing control from politicians, stating, "JESSI is an action of industry and its structure should be determined through the incorporation of the user groups and not through controlling interventions of the state." In addition, he confirms that the "big companies," Bosch, for example, would not really need a project like JESSI for system development because "they deal directly with the semiconductor manufacturers."

### Laender Compete for Funds

90CW0040D Stuttgart VDI NACHRICHTEN in German 27 Oct 89 p 8

[Article by Wolfgang Mock: "Land Politicians Compete for the Favor of Researchers"; first two paragraphs are VDI NACHRICHTEN introduction]

[Text]

### JESSI: A Technology Driver for the Laender—New Research Institutes Accelerate the Structural Change in the North.

Schleswig-Holstein and Lower Saxony have emerged victorious from the hard struggle for location of JESSI activities. Nevertheless, other laender are also using their

own funds to try to prepare their research facilities for participation in the microelectronics project.

The sigh of relief in Kiel was great: On Thursday of last week the final hurdle for the planned ultracleanroom laboratory in Itzehoe was overcome. The senate of the Fraunhofer Gesellschaft (FhG), under whose direction the institute will fall, approved construction. "For us," according to Klaus P. Friebe, the ministerial secretary responsible for JESSI in the Kiel Ministry of Trade and Commerce, "this is not merely an additional stone in the mosaic of the structural change of our land, it is a diamond." It is above all the first Fraunhofer Institute in the northernmost German federal land. Minister-President Bjoern Engholm had just spoken of a "great leap forward" for his land "the significance of which cannot yet be fully appreciated."

With federal participation of DM200 million, a new Institute for Silicon Technology (ISiT) will be built in the vicinity of Itzehoe; here again the land will contribute matching funds. Twenty percent of the personnel will come from industry; one third of the institute's capacity will be dedicated to application-ready development and will be financed by industry by means of research and development contracts. Within the framework of JESSI activities, research performed here will be primarily in the area of the basic principles of silicon technology.

Schleswig-Holstein has provided 75 hectares: The Fraunhofer Gesellschaft will use one third for its institute with the remainder earmarked for industrial sites. According to Friebe, construction will begin next year, planning activities have been taken care of, and the industrial buildings are already in place. Siemens, Philips, and Telefunken are the first industrial partners. The institute will begin operation at the end of 1993 with 400 persons ultimately employed there, including 160 scientists.

### New Demands on Education

To be able to meet this demand regionally, Schleswig-Holstein is currently negotiating with technical universities and occupational training centers concerning the new certification requirements which will emerge for graduates of the land's educational institutions over the long term with a project such as the ISiT and the anticipated resultant location of new industries. Development of a technical school is also planned, but the question of its location has not yet been settled.

Since the 1988 change in government, Schleswig-Holstein has backed the location of technology-oriented companies and research facilities even more strongly than before. With the Fraunhofer Society's selection of Itzehoe, Minister of Trade and Commerce Franz Froschmaier considers his policy "fully confirmed."

The federal government was equally generous toward Lower Saxony as in the far north. The fact that Landtag [state parliament] elections are being held there in early 1990 might have been a contributing factor. With DM300 million, half of it from Bonn, a "Society for

Silicon Applications and CAD/CAT of Lower Saxony (Sican GmbH) is being established in Hannover, which, as a JESSI project leader, will work primarily in the areas of chip production and computer aided testing. The site of the institute with almost 100 scientific employees will be the city's planned science park on the former Varta grounds. Negotiations are still in progress concerning the amount of industry's financial participation; however, according to a spokesperson from the Ministry of Trade and Commerce, "It will not be small."

An additional DM45 million is going to the Institute for Applied Microelectronics in Braunschweig and another DM30 million to the Laboratory for Information Technology at the University of Hannover. In both cases the federal government is contributing half of the funds.

Other laender are also hoping for funds from Bonn. Among other things they are attempting by their own measures to prepare their universities and research facilities for participation in JESSI projects. Thus, in North Rhine-Westphalia an attempt is being made to create a broader base for the CAD Lab, a research facility supported by the Gesamthochschule [polytechnic university] of Paderborn and Nixdorf, which concerns itself primarily with the development of CAD software, through integration of other universities such as Dortmund and Duisburg and additional industrial partners. Especially the firms participating in the JESSI user group such as BMW, Bosch, AEG, Krupp-Atlas, and SEL should be interested in this. The CAD Lab hopes, according to a spokesperson, for support from Bonn "about equal to that for Hannover."

#### The Laender Are Assuming a Competitive Stance

With almost DM500,000, the North Rhine-Westphalia Ministry of Science has supported chairs at the universities of Paderborn, Dortmund, and Aachen to provide the foundations for JESSI participation here. Also, in Aachen, an institute where research activities for JESSI are to be coordinated is being planned at a cost of DM54.2 million. However, other plans are faltering since Minister of Science Anke Brunn prepared for JESSI in her own way: The expert formerly responsible for microelectronics has been taken out of action and transferred to the press department.

And the southern German laender are not idle either. JESSI's steering and coordination committee has been headquartered in Munich since mid-year, and the FhG Work Group for Integrated Circuits in Erlangen has established collaboration with the Stuttgart Center for Semiconductor Fabrication Devices based on their common interest in the JESSI area Devices and Hardware.

This center—a joint initiative of the FhG Institute for Production Technology and Automation, the Stuttgart Institute for Microelectronics, and the Institute for Technical Optics is generously supported by the land government with DM20 million for JESSI projects over the next 3 years. If the industry indicates a need for it, the Research

Center for Information Sciences in Karlsruhe will also obtain increased financial support from the land.

#### FRG: Siemens-AEG Joint Venture for High-Power Components

36980009b Paris AFP SCIENCES in French  
26 Oct 89p 21

[Article: "FRG: Siemens-AEG Joint Venture for High-Power Components"]

[Text] The West German companies Siemens and AEG (subsidiary of Daimler Benz), will make a joint venture for the production of high-power components for the electronics industry on 1 January 1990. In a press release published on 24 October, Siemens and AEG indicated that the company, named EUPEC (European Power-Semiconductor Company), will be given a capital of DM50 million shares being held equally by each of the two parent companies.

Each parent company will provide the joint venture with its expertise in the high-power component area. The press release also stated that EUPEC, which will be located at Warstein-Belecke (Westphalia), will employ 700 people initially and direct worldwide development of production and marketing for electronic high-power components. EUPEC is expected to become a leader in the market.

In December 1988, the largest West German electronics companies had announced their intention to form a joint venture. In 1989, AEG will have achieved a business volume of approximately DM85 million in the field of high-power components out of a total business volume of DM13.4 billion. Siemens has announced sales of approximately DM70 million out of an overall business volume of DM59 billion.

#### France: Thomson To Build Flat Panel Display Factory

36980009a Paris AFP SCIENCES in French  
26 Oct 89p 23

[Article: "Thomson Builds a Flat Panel Liquid Crystal Display Factory"]

[Text] On 24 October, Michel Hannoun, mayor of Voreppe (Isere department), signed an agreement with Thomson for the construction of a flat panel liquid crystal display factory in the "Centr Alp" [as published] industrial zone of Voreppe. This investment of approximately Fr100 million will create about 100 jobs within the next 2 years.

Erich Spitz, president of Thomson LCD, stated that the factory, together with a research center, has a floor space of 4,400 square meters, 1,000 square meters of which is clean room facilities. It is to begin production in mid-1990. The factory will serve primarily to produce small series of aeronautical and military displays and as a pilot line for consumer products.

When Thomson has mastered the production of large flat panel liquid crystal displays, it envisions building on the same site a series production plant for flat panel displays aimed at the consumer electronics market. Currently, 80

million televisions are sold each year worldwide. Only 1.2 million of these are pocket televisions, which are the only ones that use flat panel liquid crystal display technology.

## COMPUTERS

**GDR's Strategy for Interconnecting  
UNIX-Compatible Computers**

23020092 East Berlin MIKROPROZESSORTECHNIK  
in German, Aug 89 pp 227-228

[Article by Detlef Gierrth and Uwe Inhoff: "Interconnecting UNIX-Based Computers"]

**[Text] Introduction**

With the introduction of MUTOS, WEGA and VMX, a largely unified operating system environment has been established for all 16- and 32-bit computers manufactured in the GDR, as well as for ESER computers, in which standardized UNIX interfaces are implemented. The performance capabilities of this operating system are described in [1] and [2].

The rapid proliferation of this system brings with it the requirement that the various computers which run these operating systems be able to communicate with each other for the following reasons:

- 1—It must be possible to access common files and data resources.
- 2—Other systems must also be able to access expensive peripherals (e.g. fast printers, plotters, etc.).
- 3—The transfer of data by means of transportable media (diskettes, for example) is a time-consuming process, and not all computers support the same media.

Compatibility among operating systems makes it easy to exchange data between different computers. The UUCP software package [3, 4] allows the user simple on-line

connectivity, and at the same time provides an extremely high degree of data security.

The documentation which goes with the different UUCP components for the operating system in question contains a complete set of operating instructions, and also describes in great detail how the software works and how to implement it. The special considerations to be kept in mind in interconnecting different types of computers are described below. This article is intended to help users who have already familiarized themselves with the UUCP software package using the corresponding documentation to establish heterogeneous computer networks.

**The UUCP Software Package**

The UUCP permits different computers running a UNIX-compatible operating system to form a network. Within this network it is possible to transfer all files safely and in the same manner, regardless of the type of computer used; remote commands can also be processed.

At present, the following computers can be interconnected using UUCP:

Computer Type	Operating System
K 1840	MUTOS 1800
K 1630	MUTOS 1630
P 8000	WEGA
A7100/7150	MUTOS 1700
EC 1834	MUTOS 1834

No special hardware is required for connection to the network. Computers are interconnected via terminal interfaces which are also used for operation of the local terminals. These terminal links produce the transmission paths which can be used for interconnection. These are listed in Table 1.

**Table 1.**  
**Possible UUCP Connection Paths**

Interface	Transmission distance in (baud)	Transmission rate
IFFS	max. 9600	up to 500 m
V.24 direct	max. 9600	up to 15 m
V.24 with local data transmission equipment (DNUE K 8172)	1200	up to 30 km
(four-wire)	9600	up to 10 km
V.24 with modem	max. 2400	unlimited

All computers in the network may establish a connection to one or more partner computers at any time. The exchange of data can therefore take place directly between two linked computers, or indirectly via network nodes.

**Connecting Computers of Different Types**

The UUCP versions implemented on the different computers are compatible in terms of transmission protocols

and user interface. For the UUCP user, the software operates the same way regardless of the partner computer type.

Differences between the various computers exist in terms of the design of the physical line connections and in the coding of the initial character used in the system log-on procedure. These differences must be taken into consideration when configuring a network, but have no effect during subsequent use.

**Physical Connection IFSS Connection**

Data can be transmitted over distances of up to 500 m using the current-driven serial IFSS interface. It requires the following lines:

- transmit data - (TD-)
- transmit data + (TD+)
- receive data - (RD-)
- receive data + (RD+)

The lines between two computers are to be connected as follows:

TD- to RD+ TD+  
to RD-RD-  
to TD+ RD+  
to TD-

Table 2 shows the pin assignments for active transmitters and passive receivers.

**V.24 Direct Connection**

The voltage-driven serial V.24 interface allows transmission over distances of up to approximately 15 m. The

following V.24 interface lines are required for connecting computers via a direct connector cable:

	CCITT Designation
System ground (SG)	102
Receive data (R x D)	103
Transmit data (T x D)	104

The *receive data* line of one computer is to be connected to the *transmit data* line of the other computer. The shield is to be connected to system ground at one end.

**Connection to Data Transmission Equipment**

In order to bridge great distances, data transmission equipment must be inserted into the transmission path. Table 1 shows the possible transmission distances and speeds with this equipment.

Care must be taken in selecting the transmission equipment to ensure asynchronous duplex data transmission. Accordingly, only the control and signaling lines of the V.24 interface required for the asynchronous duplex mode are used.

**Table 2.  
Pin Assignments for IFSS Connection**

	A7100/7150 and K 1840	K 1630	EC 1834	P 8000
Connector	Cannon 25-pin	EFS 5-pin	Cannon 15-pin	Cannon 25-pin
Pin assignment	RD+-14 RD-13 TD+-19 TD-10 Shield -1	RD+-A3 RD-B4 TD+-B2 TD-A1 Shield -A5	RD+-12 RD-15 TD+- 9 TD-10 Shield -1	RD+-13 RD-14 TD+-10 TD-19 Shield -7 Jumper 7-9 inside connector
Remarks		Do not use channel 1A (transmission timing fixed at standard setting in clock dis- tribution field)		As of version number V.43xx (production startup 3/89): RD+-14 RD-13 TD+-19 TD-7 Shield -7 Jumpers: 12-10 9-7

**Table 3.**  
**Pin Assignments for Direct V.24 Connection**

	A7100/7150 and K 1840	K 1630	EC 1834	P 8000
Connector	Cannon 25-pin	EFS 26-pin	Cannon 15-pin	Cannon 25-pin
Pin	R x D-3	R x D-B04	R x D-3	R x D-2
Assignment	T x D-2	T x D-A03	T x D-2	T x D-3
	SG -7	SG -A01	SG -7	SG -7
Remarks	If there is a direct V.24 connection via an AMF channel which is pro- vided for modem operation with K 1840, the null modem function must be set in the connector	Use channel 2A; supply clock pulse T2 instead of T2H (jumper X1701-X1705)		As of ver- sion no. V.43xx: R X D-3 T x D-2 SG-7

All of the computers in Table 4 can be interconnected using data transmission equipment, however the extent of interface control varies from computer to computer. Complete modem control with monitoring of the signaling lines of the data transmission equipment exists only for the K 1840. The A 7100/7150 and EC 1834 computers have an automatic ready function for the data transmission equipment (within the "open" function). However, the signaling lines are not read. On the K 1630, the control lines are not used; the readiness of the data transmission equipment must be set via hardware by means of a jumper in the connector (see Table 4).

These differences in the operation of the interface lines have no effect on utilization of the connection, however. Even if the signaling lines of the data transmission equipment are not read, the data security protocol in the UUCP ensures reliable transmission of the data.

#### Logical Network Configuration

A description of the current configuration of the network is stored in each computer in some of the files used by UUCP (L.sys, USERFILE, SQFILE). These files are in text format and must be set up during the installation of UUCP. Detailed descriptions of these files are contained in the UUCP documentation for the individual operating systems.

When connecting different types of computers, the different coding of the initial character for system log-on and the possibly different transmission rate are to be taken into account. The format for the above-mentioned configuration files is the same for all UUCP systems. The only

difference is the way in which the initial character is represented for logging on to the partner computer.

Table 5 lists examples of the entries in an L.sys file which demonstrate this type of representation. The names of the individual computers were used here as the names of the partner systems. The entries for the A 7100/7150, K 1630 and EC 1834 are identical and are therefore listed only once.

The characters D and Z were used here to represent the codes 004 and 032 (octal).

In the WEGA operating system, each user entry in the password file must contain a password (also the entry for UUCP). In the MUTOS systems, the specification of a password is optional.

#### Connecting MUTOS/WEGA to Other UNIX-Compatible Systems

It is possible to connect MUTOS and WEGA to other computers with UNIX-compatible operating systems (e.g. personal computers running XENIX, SINIX ...) using the UUCP software package if the UUCP components are available there. It must be kept in mind, however, that in most of the computers where UUCP is implemented, establishment of the connection via a terminal line is possible only in one direction, i.e., one partner assumes the role of MASTER, while the other passive partner acts as the SLAVE. If the establishment

of the connection from both sides is permitted, two lines must be used for the connection. With MUTOS and

WEGA, it is possible to establish an equal-access connection from both sides via one line.

**Table 4.**  
**Pin Assignments for Connecting Data Transmission Equipment**

	A7100/7150	K 1630	K 1840	EC 1834	P 8000
Connector	Cannon	EFS	Cannon	Cannon	Cannon
	25-pin	26-pin	25-pin	5-pin	25-pin
		for 2 channels			
Pin	T x D(103)-2	T x D-A03	T x D -2	T x D -2	T x D -2
Assignment	R x D(104)-3	R x D-B04	R x D-3	R x D-3	R x D-3
	RTS(105) -4	RTS -A05	RTS -4	RTS -4	RTS -4
	CTS(106) -5	CTS -B06	CTS -5	CTS -5	CTS -5
	DSR(107) -6	DSR -A07	DSR -6	DSR -6	DSR -6
	DTR(108) -20	DTR -B08	DTR -20	DTR -13	DTR -20
	DCD(109) -8	DCD -A09	DCD -8	DCD -8	DCD -8
	DSRS(111) -23	DSRS-B10	DSRS -23	DSRS-12	
	SG(102) -7	SG -A01	SG -7	SG -7	SG -7
	PG(101) -1	PG -B01		PG -1	
		for channel A			
Remarks	CCITT designation in parentheses;	Use channel 2A; supply T2 clock pulse instead of T2H (jumper X1701-X1705); DSRS on via AIS; RTS, DTR on via jumper in plug;	Only the first two channels of each AMF for modem operation (e.g. ttyh0 and ttyh1 on 1st AMF); "open" means RTS, DTR, DSRS on; DCD monitored	"Open" means RTS, DTR, DSRS on	As of Version V.43xx: only tty0 and tty4; circuit modifications required for all other devices; "open" means RTS, DTR on
	DSRS on ASP is on; "open" means DTR and RTS on	on via jumper in plug: A05-B08-B10			

**Table 5.**  
**Examples of Entries in the L.sys File**

Local computer	
P 8000	P8000 Any tty 7 9600 tty7""NL login:-NL-login:uucp Password: Paul
	K1840 Any tty6 9600 tty6""D login:-D-login:uucp
	K1630 Any tty5 2400 tty5""Z login:-Z-login:uucp
K 1840	P8000 Any ttyh2 9600 ttyh2""CR login:-CR-login:uucp Password: Paul
	K1840 Any ttyh0 9600 ttyh0""EOT login:-EOT-login:uucp
	K1630 Any ttyh3 2400 ttyh3""CTRLZ login:-CTRLZ-login:uucp
K 1630	P8000 Any tty 1 2400 tty1""x login:-x-login:uucp Password: Paul
	K1840 Any tty2 2400 tty6""D login:-D-login:uucp
	K1630 Any tty3 2400 tty3""BREAK login:-BREAK-login:uucp

When connecting computers to another computer using MUTOS or WEGA, this computer must be permanently assigned the role of MASTER or SLAVE. If the partner computer is active (MASTER), a login procedure must be

prevented there for the connecting channel. If the SLAVE role is assigned, a login procedure for the connection channel must be active. Furthermore, *never* is entered in the *time* column in the L.sys file; this is the time allowed for

establishment of a connection. No changes are required on the part of MUTOS or WEGA computers.

With the method described above, the user tasks on the MASTER computer are executed immediately, while the tasks initiated on the SLAVE system are first stored in the spool directory. These tasks are executed only after the next connection is established by the MASTER. Establishment of this connection can also be initiated cyclically by means of a Daemon process.

#### Concluding Remarks

Using the UUCP software package, it is possible to interconnect different types of computers having a UNIX-compatible operating system with little effort and without modifying the existing hardware and software.

The user interface to UUCP is simple, since functions such as the selection of the transmission paths and parameters, buffering of the data to be transmitted or control of authorized access to the data are carried out internally by UUCP. The data security protocol used by UUCP supports the transfer of all data regardless of the type of computer used, and can therefore be used for broad range of applications.

The data transmission rate is limited due to the interface used for the interconnection. The net data rates are between 200 and 500 characters per second. UUCP is not suitable for applications in which large amounts of data must be transmitted within a very short time. In those cases, a faster transmission medium (LAN) and a network component integrated into the operating system core must be used. At present, work is progressing at the VEB Robotron-Project in Dresden on support for the ROLANET2 in the MUTOS 1800 operating system.

#### References

1. Classen, L.: "The UNIX Operating System Concept." MIKROPROZESSORTECHNIK, Berlin, Vol 2 (1988) No 8, p 227.
2. Classen, L. and U. Oefler: "UNIX and C." Berlin: VEB Verlag Technik, 1987.
3. Damme, L. and Inhoff, U.: "Support for Teleprocessing in the MUTOS 1630 Operating System Using the UUCP Software Package." NEUE TECHNIK IM BUERO, Berlin, Vol 31 (1987) No 1, p 20.
4. Hamann, Dr K. et al: "Network Software for the RVS K 1840." NEUE TECHNIK IM BUERO, Berlin, Vol 32 (1988) No 3, p 95.

#### Hungarian Central Physics Institute's Computer Net Described

25020001b Budapest COMPUTERWORLD/  
SZAMITASTECHNIKA in Hungarian 16 Sep 89 p 9

[Article by Timea Tiborc: "The 'Spider's Web' on the Mountain Top"]

[Text] The Central Physics Research Institute (KFKI) is actually five separate institutes located on several hectares on Szabadsag Mountain. It has a modern computer base, and has had for decades already. Harmonizing needs and reality has always caused much mental labor for the Measurement and Computer Technology Research Institute of the KFKI, but it has also stimulated development.

Ten or twelve years ago many people wanted to work on their existing mainframe system, so the Cedrus terminal network was born. The heart of this system was an ESZ [Uniform Computer Technology] 1040 computer, to which a TPA-70 front-end computer and nearly 20 terminals were connected. This system operated until the end of 1988 and we can regard it as the socialist countries' first truly interactive terminal network based on an ESZ computer. But a person wanting to work on it had to walk over to the building of the computer center, where the majority of the terminals were. This inconvenience was eliminated by the Lochness system (LOCAL Highspeed Network SyStem)—and the applications based on it—which was developed to control laboratory measurements and data collection.

#### Lochness—Domestic Pioneer of Network Technology

Despite its transmission speed of 1 Mbit/s it showed many similarities to the Ethernet networks so well known today. It tied together the computers in various buildings via the channel adapter of the mainframe computer. (It was given extended use in 1984-85 at the Kurchatov Institute in Moscow, where the KFKI experts tied together 15 minicomputers and a 50 microprocessor system. Here at home, in the Szabadsag Mountain institute, they also tested it with 6-8 computers, but there was no money for more than this in 1986.) This represented the dawn of local network technology for them. They still use it today for data collection in the Particle and Nuclear Physics Research Institute.

With the proliferation of computers they built an Ethernet based network, along side the Lochness, into which they are now integrating the already existing Novell local networks (these are based in part on Ethernet and in part on ARCnet) and the machines with the UNIX operating system using the TCP/IP protocol. (TCP/IP stands for Transmission Control Protocol-Internet Protocol and it is a very widespread, five layer network protocol. The US Defense Department was the first to develop it and any UNIX machine can use it. Experience with it was used by the OSI when developing the seven layer network architecture.) But the largest unit is the TPA net, which is used by the TPA computers and the ever proliferating PC's.

At the KFKI they developed a data exchange station based on a TPA-11 to connect the computer center, equipped with IBM compatible mainframes (BASF 7/61 and ESZ-1045), into the network. Various computer bases developed in the institutes with 16 bit PDP compatible minicomputers or 32 bit VAX compatible supermini and

supermicro computers and together with nearly 80 PC's these 25-30 computers are also connected to the network.

#### The X.25 Connection

Since the end of January it has been possible for them to connect into the X.25 based national network of the Post Office, the Information Infrastructure Network (IIF). This was not a simple task because here they had to integrate not a single PC but rather an entire network. The Post Office has promised that by the end of 1989 it will be possible to access international databases as well via the IIF. For the time being these can be accessed only in the KFKI library, but sooner or later everyone will be able to query such information in his own room. The KFKI will also make its own databases available to the IIF, but first a very strong data protection will have to be developed. In the research institute environment many users have full network access, which cannot be permitted to outsiders.

Unfortunately it is not possible for the KFKI to acquire a really big mainframe—because of lack of money and COCOM prescriptions—so the importance of the computer center is less than desired; its memory capacity is only a twentieth part of the total capacity of the entire system while in Western Europe this ratio is one to four.

#### If the Network Gets Tangled

Even today the network is rather complex. It consists of 37 Ethernet segments and the total length of cable is nearly 8 kilometers. The buildings are connected together by thick main cables with thin cable Ethernets within the buildings. Almost 50 different type and capacity computers work together at one time and they estimate that in the future 300-400 terminals will be able to communicate via Ethernet without a problem.

It is not easy to monitor a network of this size. Although there appears to be no obstacle to physical expansion the connection of each new workstation begins to slow data traffic in an "incomprehensible manner." Figuratively speaking the network gets tangled. What can be done? We have to look into the tangle to find the points or network layers which hinder operation.

A special system has been developed for this which also monitors it from data protection and program protection viewpoints. The network analyzer is an IBM PC compatible computer while the TPAnet and Ethernet monitors run on a two-terminal TPA-500 computer. It is possible to study the TPAnet based networks working on Ethernet at three levels; of course this does not rule out monitoring other protocols as well.

The TPAnet monitor shows the status of the network logically, "from the top of the mountain." On the monitor one can see the stations connected into the TPAnet and one can query the parameters and status states important from the viewpoint of the net. In the next step

the Ethernet monitor takes the system apart. The Ethernet hardware devices appear also—the concentrators, the repeater stations and the group connectors, which are also microcomputers themselves and which make possible the spider's web structure of the Ethernet and the connection of new branches. One can also see here the ARCnet and TCP/IP islands which are connected. Finally the PC analyzer examines the physical layer. It notes, for example, the transmission errors which unnecessarily reduce the transmission speed.

One can also intervene in the life of the network. Knowing the more important parameters of every station the operator can turn personally to the owner of the station or can shut it out via the monitor. He can increase the receiving storage of a station and switch connectors in or out without bothering the user.

"We built control into our system in advance. You not only have to put a network into operation, you have to see that it keeps on working as well. To use a simile, the Mercedes is a good car only if its owner takes care of it, pays attention and remedies even minor disorders," said Ferenc Telbisz, chief of the network department.

And he mentioned as a direct advantage that software can be installed in any computer easily and quickly. The expensive peripherals which cannot be there beside every computer can be utilized well. The PC's have a gigantic amount of data traffic in the institute; this would be difficult on disk, not even to speak of their compatibility problems. There is no incompatibility in the network, and this has completely transformed the distribution of peripherals, software, background memories and resources.

The significance of electronic mail today is greater than when it was first used. It offers much more than the "I am here, are you here too?" messages and it eliminates the disadvantages of other communications channels. A letter is slow; the telephone is fast but it is difficult to transmit equations or foreign expressions by voice; and for the time being telefax cannot be integrated directly into computer programs.

The KFKI resources are as follows:

Computer center—a BASF 7/61 and an ESZ-1045, a total of 8 megabytes of memory with 4.4 gigabytes of background.

Institutes and laboratories—twentyfive to thirty 16 and 32 bit TPA's, a total of 150-170 megabytes of memory with more than 10 gigabytes of background.

Desktop computers—about 80 PC XT's and AT's, a total of nearly 95 megabytes of memory with nearly 2.4 gigabytes of background.

## FACTORY AUTOMATION, ROBOTICS

### Hungarian Joint Venture To Use CAD/CAM in Plastics Industry

25020001a Budapest *COMPUTERWORLD/SZAMITASTECHNIKA* in Hungarian 16 Sep 89 p 1

[Article: "CAD/CAM in the Plastics Industry; Tool Design with HP Computers"]

[Text] In the middle of September no fewer than eight firms will sign a document founding a new mixed enterprise which will manufacture plastics industry tools with a CAD/CAM technology close to the COCOM limit. The eight founders are Pannonplast, the Hungarian Credit Bank, the Industrial Development Bank, Noviki, the West German Wilden firm (as technical development partner), the Swiss MEF and GERH and ventures involved in machine tool trade. If the founders approve it the name of the new firm will be DEXTER. So far they have referred to it as "a machine tool manufacturing company in Hungary." The base capital of the new enterprise is 350 million forints (Pannonplast provided 40 percent of this and the foreigners provided 30 percent) and it received 370 million forints in World Bank loans, in order to provide tool manufacture for the Hungarian plastics industry, now being reconstructed, that is to produce tools in sufficient quantity with appropriate quality within competitive time limits. According to plans production will begin in April 1991.

Throughout the world those manufacturing machine tools to process plastics solve their tasks with computerized design and manufacturing systems. World Bank credit is a condition for obtaining such a CAD/CAM system. Unfortunately, as we learned from Antal Monostori, the project leader, they were unable to get the optimal, three-dimensional software because of COCOM restrictions. They accepted the best of what could be obtained, the Leonardo software offered by the West German Borgware firm. This was developed for HP9310 computers. The software is suitable for only two-dimensional designing, so, for the time being, the West German partner will design products requiring three-dimensional surface design (for example, small housekeeping machines). The investors trust that during the 18 months of development, due to relaxation, the three-dimensional modules of the software will be removed from the list of embargoed products so that they can be purchased as well. They are also talking with SZTAKI [the Computer Technology and Automation Research Institute] regarding rewriting their FFS surface modelling software for HP computers, in-so-far as it proves suitable.

The CAD/CAM system—if it is realized—will be one of the most modern designing and manufacturing systems in our country. It will be based on five HP9310 workstations connected into a local network, each with 4 megabytes operational memory and 81 megabytes of

background memory. The plan is to have the central designing section in Budapest, then the plans will be taken on magnetic disk to the manufacturing shops in various parts of the country.

### Computer-Controlled Insertion Device for Circuit Boards Described

90CW0016a East Berlin *NACHRICHTENTECHNIK-ELEKTRONIK* in German Sep 1989 pp 350-351

[Article by L. Hempel: "Computer-Controlled Insertion Device for Circuit Boards"]

[Text] Report from the state-owned Nachrichtenelektronik company in Leipzig

#### 1. Producing circuit boards with limited piece numbers

Modern electronic factories must be able to convert circuit board insertion devices quickly, so that they can be adapted to the increased demands of our clients in accordance with the world market. This requires a special programming station, which determines the technological insertion of circuit board sectors. The data is acquired at the technologist's station with the aid of menu-driven software. The variable fields created in this way are deposited on a magnetic band as data carriers. A programming time of 35 minutes per 100 bipolar components is required. Modification service is possible with appropriate software, and texts and symbols can be added and deleted rapidly.

#### 2. The main symbol option on the inserted circuit board

First, the magnetic tape storage is bonded into the insertion device. The insertion device operates according to a newly developed display principle, whereby the monitor's color picture is reflected on a special glass plate. The symbols appearing on the circuit board have defined contours, so that the electronic components can be mounted in the right position and with the right bonding. All insertion errors are eliminated with this positioning technique. According to experimental values, the failure ratio is 0.1 percent. Through two-handed operation, the control field of the circuit board has good optic visibility. The next symbol is generated by using the foot switch. The insertion device can be used either as a mounting device in suitable storage bins or more rationally by combining it with the computer-controlled paternoster storage area. The precise removal of the pertinent components is linked to the characteristic of the symbol option.

#### 3. Which electronic devices are used with insertion technology?

Industry standard devices are used for the control computer with a control keyboard and color monitor. The insertion device is CAD/CAM expandable, should the program written during the computer-controlled construction of the circuit board also be used as the operating program for the insertion device.

Basic diagram for Installing the Insertion Device for Circuit Boards

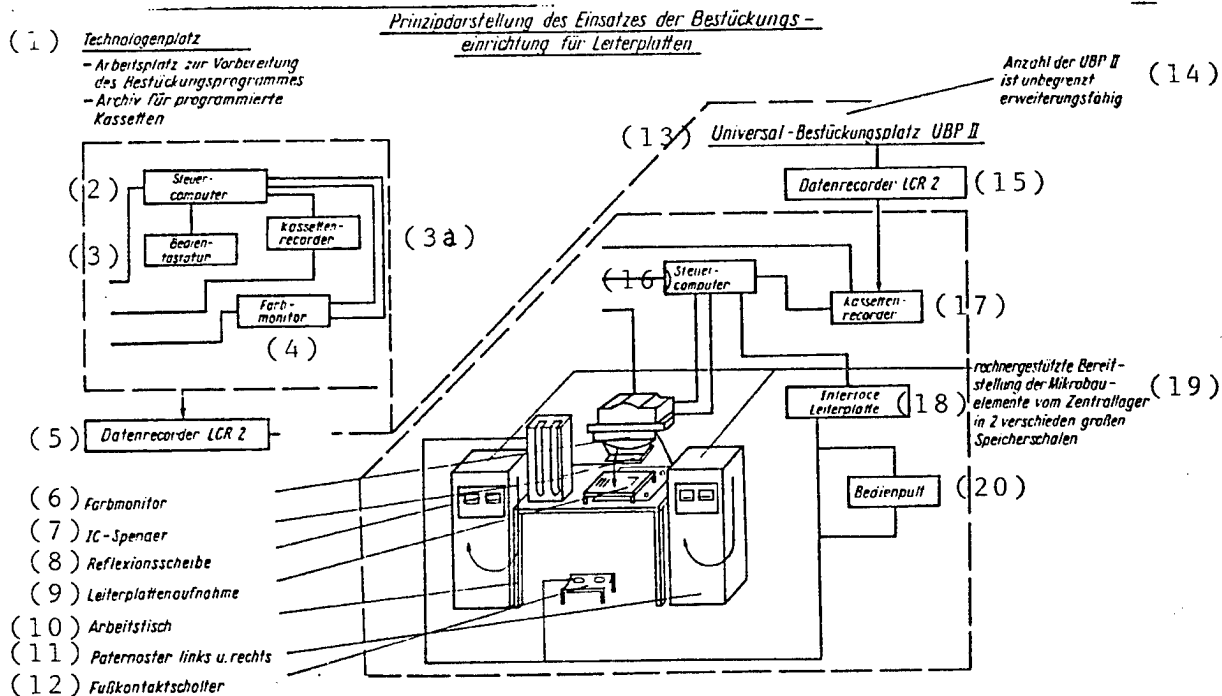

Key:—1. Technologist's station—2. Control computer—3. Control keyboard—3a. Cassette recorder—4. Color monitor—5. Data recorder LCR 2—6. Color monitor—7. IC dispenser—8. Reflection plate—9. Circuit board receiver—10. Work table—11. Left and right paternoster—12. Foot switch—13. Universal insertion station UBP II—14. Expansion capability of the number of UBPs is unlimited—15. Data recorder LCR 2—16. Control computer—17. Cassette recorder—18. Interface circuit board—19. Computer-controlled preparation of the micro-components from the central storage in two different sized shells—20. Patch panel.

4. Main technical data

- Total weight (insertion device with work table, monitor, and receiver stands): approximately 250 kg;
- Operating voltage and connection output: 220 V/50 Hz, 0.7 kVA;
- Required floor space: length approximately 2200 mm, width approximately 1600 mm, height 2300 mm;
- Paternoster component storage with 48 storage shells: 2, each with a volume of 920 cm<sup>3</sup>, or, with 24 storage shells, each with a volume of 1840 cm<sup>3</sup>;
- IC-storage with 32 magazines: external storage capacity for 200 variants;
- Size of the inserted circuit boards: maximum 175 x 255 mm; and
- Positioning accuracy of the light symbol transmission: + or - 0.3 mm.

5. Applications

The insertion device allows continual, user-friendly, two-handed insertion. Displaying various components of

one type simultaneously and inserting them in one step saves considerable insertion time compared to other insertion stations with only one light point display. The insertion time for one bipolar component is 3 seconds, or a savings of 5 minutes per 100 components.

It is estimated that the insertion device for average circuit board piece numbers in the multilayer system is amortized in 2 to 3 years.

Microelectronics Component Symposium Exhibits New Products

90CW0042A East Berlin  
MIKROPROZESSORTECHNIK in German  
No 10, Oct 89 pp 2-3

[Text]

13th Microelectronics Component Symposium

In keeping with tradition, the 13th component symposium focusing on microelectronics was held in May in Frankfurt/Oder. The sports and exhibition center at Westkreuz was again used. The organizers were the Microelectronics Combine and the Chamber of Technology of Frankfurt/Oder. The symposium was held

under the patronage of Minister for Electrical Engineering and Electronics Felix Meier. After the plenary speeches by the minister for electrical engineering and electronics and by the Microelectronics, Carl Zeiss Jena, Robotron, Automation System Construction, and Communications Electronics Combines, the 2,400 participants were offered a program of 56 technical presentations about new components and their application.

Exchanging experiences is assuming an ever-greater importance at the component symposium. The exhibit area, measuring 1,200 m<sup>2</sup>, with 850 components on display and 195 exhibits by user industries, academies, and colleges, as well as the podium discussions and the poster debates, provided adequate opportunity to do so.

Of particular interest were the integrated circuits from the U 80600 and U 84C00 microprocessor systems (first exhibited at the Leipzig Spring Fair), the U61000 1-Mbit DRAM [dynamic random-access memory] and the U 5300 and U 1600 application-specific circuit systems. The U 6264 8-kbyte SRAM [static random-access memory], the U 2764 8-kbyte EPROM [electrically programmable read-only memory], and the fast U74HCT CMOS [complementary metal-oxide semiconductor] logic family were presented, and experiences in using surface-mountable components were conveyed.

We provided you with detailed information on the U 80600 16-bit microprocessor system in MIKROPROZESSORTECHNIK No 5, 1989; in this issue, we will present the U 61000 1-Mbit DRAM and the U 84C00 8-bit CMOS processor in greater detail.

The announcement of an accelerator card based on the U 80601 should be of interest to users of the EC 1834. The BK 600—also call a turbo card—makes it possible to accelerate the computing speed of the EC 1834 by three to four times. Where a coprocessor is used, a factor of five to eight is even possible. The card represents a complete subsystem that in the EC 1834 can be inserted in place of the RAM expansion. It handles processing of all operating system, driver, and user programs, whereby the original processor system continues to be used as a slave system. This ensures access to all system resources. The RAM area of the EC 1834 can thus be used as a disk cache for hard and floppy disks. The component basis for the turbo card, which is the result of joint work by the Microelectronics and Robotron Combines, are the U 80601, U 80613, DS 224, U 80606, U 41256-15, U 214 D, and U 6514 D circuits and the DL and DS logic array.

Of the exhibits on display at the fair, we have selected a few that we would like to present here in brief.

The Wilhelm Pieck University in Rostock, Department of Technical Electronics, displayed the SBC-WPU-80601 16-bit single-board computer. The SBC in DKL technology, measuring 233 mm x 330 mm, was presented with the following circuits: 80286 CPU [central processing unit], 82284 clock, two 82288 bus controllers, 82289 bus arbiter, 80287 math processor, two 8259A interrupt controllers, V.24/IFSS interface with

USART 8251A, 8253 timer, four 6264...62256 static RAMs, and four 2764...27256 EPROMs. The SBC-WPU-80601 constitutes the central unit in a modular system with MMS-16 global and local bus and SBX bus with SCSI [small computer system interface] adapter. Moreover, system-specific additions were introduced: Graphics module with 82720 and MMS-16 bus, Winchester controller with 82062 and SBX bus. In function, the console coupling of the SBC with the SCSI interface was presented. The software consists of the 957B monitor with expansions, SCP [system control program] and DCP [data control program] in the CPU's real address mode. With examples, the functional principle of protected mode was shown. The graphics module permits a display of 800 x 800 pixels, and a demo on the color monitor illustrated a new level of quality in terms of resolution and representation.

The Center for Scientific Equipment Building of the Academy of Sciences offered a 4-Mbyte RAM floppy card and the VIS 3 video drive. The 4-Mbyte RAM floppy is well-suited for expanding the memory of the EC 1834 as well as that of compatible computers after EMS 3.2 (see also MIKROPROZESSORTECHNIK No 3, 1989, p 89). It can serve as fast data memory for recording measurements or as cache memory for hard disk access. The parity check is ensured with the obligatory memory units of 9 bits per byte. Support through an external voltage feed and autorefresh are possible. The card has U 61000 CC12 1-Mbit DRAMs (access time 120 ns); the variation with 1 Mbyte was on display. The VIS 3 is used to drive color monitors that can be used as full graphic displays for image processing and for computer graphics. In particular, it is suitable for applications where an existing 8-bit microprocessor system is to be supplemented by a graphics-capable, color image-output system. The VIS 3 was already introduced in great detail in MIKROPROZESSORTECHNIK No 3 and 11, 1988.

In order to relieve the design centers, and because the design of application-specific integrated circuits (ASICs) in the design centers is not effective for each user, there is an increase in demand for design with the PC. The parts design work station at the Technical University of Karl-Marx-Stadt for the EC 1834 demonstrated the PC-GAD design system (Technical University of Karl-Marx-Stadt) and MELGET (Metallurgy Electronics, Leipzig) for designing the U 5200 and U 5300 gate array systems. The PC-GAD, which is compatible in network-description and command language to the ARCHIMEDES system for the K 1840, allows the design and simulation of circuit elements with up to 300 macros. Further information about this can be found in our ASIC series in MIKROPROZESSORTECHNIK No 3, 6, and 9, 1989.

In the 3 years of its existence up to the beginning of this year, the Integrated Circuit Center at VEB Textima Electronics, Karl-Marx-Stadt, has performed design work on 30 U 5200/5300 gate array circuits and on five U 1500/1600 standard cell circuits. At the symposium,

the Integrated Circuit Center provided information on logic cell arrays (LCAs), with which the development time of printed circuit boards can be sharply reduced. Where quantities are small, they can also fully replace ASICs. LCAs—similar to EPROMs—are programmed on the PC and used like ASICs. In this way, LCAs are highly flexible. They are easy to change and to test; reprogramming is possible in a few minutes. LCAs consist of a number of configurable logic blocks (flip flops and complex combinatorial logic functions). There are input/output blocks for communicating with the environment. All the blocks can be connected to each other, with no limitations. A software package contains components such as graphics editor, interactive computation of signal running times, macro cell libraries, automatic positioning and routing, as well as dynamic simulation support.

Component symposia have been held in Frankfurt/Oder since 1966. To this day, they are application-oriented events that are unique in the GDR in terms of size and significance. With the wide range of information options, including the sale of informational material and of components, the symposium fully lived up to its reputation as the most important source of information for all users of integrated circuits in the GDR.

#### GDR's PCM 30-400/800 Radio Relay System Described

90CW0035A East Berlin NACHRICHTENTECHNIK-ELEKTRONIK in German No 10, Oct 89 pp 375-377

[Article by Egbert Rempt, Dresden Chamber of Technology: "The PCM 30-400/800 Radio Relay System and Its Potential Applications"]

[Text] For many years now, the VEB combine Robotron has been producing radio relay systems that have proven their worth both at home and abroad.

As part of the new generation of digital radio relay equipment, Robotron produces the PCM 120-2000 and PCM 10-300/400/800 units. PCM 120-2000 lines transmit a digital signal of 8.488 Mbit/s, which can contain, for example, a trunk group with 120 PCM channels in the 2-GHz radio frequency range. The PCM-10 unit noted above is designed for 704 kbit/s and transmits a trunk group of 10 channels at 64 kbit/s in the 300 MHz, 400 MHz, or 800 MHz radio frequency ranges.

It has a system-specific multiplexer with voice and/or data channel connections.

In order to complete this line of low-channel digital radio relay systems, Robotron is in the process of developing a device to transmit a digital signal at 2.048 Mbit/s, which can function in the 400 MHz or 800 MHz radio frequency ranges, called the PCM 30-400/800. The transmission capacity corresponds to a trunk group of 30 channels at 64 kbit/s, which can contain digitalized voice signals or data.

This PCM-30 radio relay system is intended for use in rural and suburban areas of public telephone networks, as well as in special networks. Furthermore, it is suitable for rapidly realizing an overlay data network with an existing analog telephone network without digitalizing the main lines.

#### 1. Design and Functions

A PCM-30 radio relay station consists of several sub-racks measuring 120 mm in width and 200 mm in depth, in a narrow-frame construction. The corresponding frames, with nominal heights of 480 mm or 2 m, make it possible to position these sub-racks either beside or on top of each other. The 480-mm frames are directly mountable on a wall, on a table, or in a swing frame for varying the place of operation. Figure 1 [not reproduced] shows a view of a terminal, Figure 2 the sub-rack arrangement of a terminal and relay station in 480-mm frames.

Besides the sub-rack groups noted, a PCM-30 radio relay station also includes one antenna for terminals and two antennas for relay stations, as well as a 48-V battery for the continuous standby power supply, if necessary. In the 400-MHz range, logarithmic-periodical antennas with 7 dB gain are used, while at 800 MHz, reflector antennas with 16.5 dB gain are used. Higher gain can be achieved with group arrangements of these antennas.

Table 1 contains the main characteristic values of the PCM 30-400/800.

**Table 1.**  
**Main characteristic values of PCM 30-400/800**

Frequency ranges	390 to 470 MHz or 790 to 960 MHz
Channel screen	125 kHz or 250 kHz
Duplex interval	greater than or equal to 24 MHz
Normal radio field length	50 km
Transmission capacity	2.048 Mbit/s
Relay-internal bit rate	2.176 Mbit/s
Type of modulation	differential 4 PSK
Transmitter output level	
Normal	1 W (+ 30 dBm)
Option	5 W (+ 37 dBm)
Receiver noise level	2.5 dB
Interim frequency	70 MHz
Bit error rate/radio field	
- in 0.5 percent of the time (month)	greater than or equal to $10^{-6}$
- in 0.2 percent of the time (month)	greater than or equal to $10^{-3*}$

In order to digitally transmit the service and auxiliary signals, a radio relay-internal impulse frame with a length of 544 bit is formed. Within this, four 8-bit groups with internal information are added to the useful bit current. This results by necessity in an increase in the bit

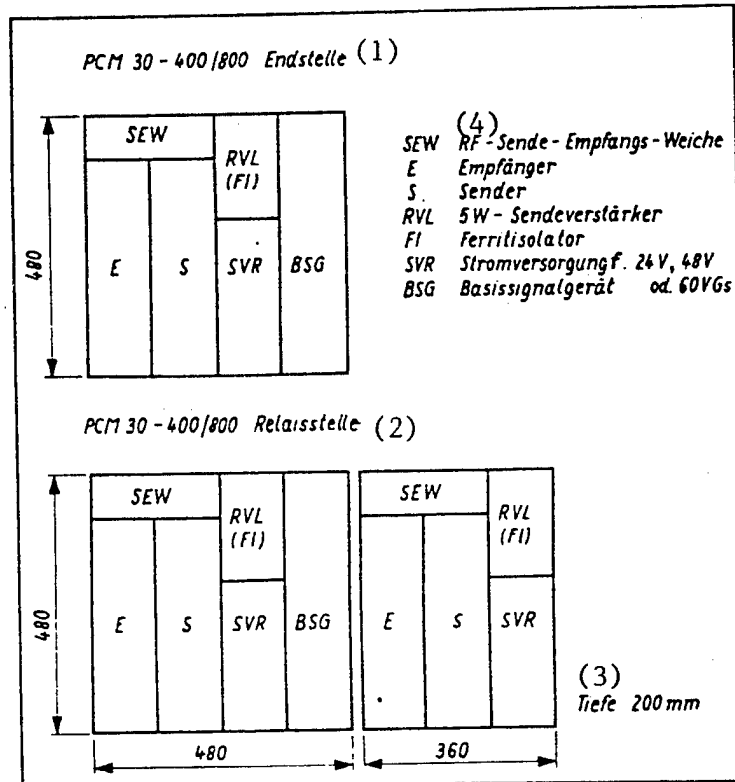

Figure 2. PCM 30-400/800 radio relay system. Arrangement of the sub-racks for a terminal station and for a relay station in 480-mm frames.

Key:—1. Terminal station—2. Relay station—3. Depth—4. SEW RF transmitter-receiver filter; E Receiver; S Transmitter; RVL 5 W transmitter amplifier; FI Ferrite insulator; SVR Power supply, 24 V, 48 V; BSG Basic signalling unit

rates used in the radio relay path by around six percent, to 2.176 Mbit/s. This additional transmission capacity is used for

- a service channel transmission with PCM quality and digital out-of-band ringing.
- the transmission of remote monitoring signals less than or equal to 300 bd
- the availability to the user of two data channels with less than or equal to 300 bd
- error rate monitoring during operation
- identification signal for radio frequency channels during common-channel operation
- possible diversity operation with error rate-controlled switching between operating and substitute channel

The PCM 30-400/800 radio relay system operates with differential four-stage phase-shift keying of the radio-frequency carrier (4 DPSK) and coherent demodulation. On the transmitting end, the 2.048-Mbit/s useful signal to be transmitted (adjacent to the input in HDB3 code) passes through a scrambler and a difference coder after insertion of the auxiliary signals (Figure 3). The signal

that has been thus processed is fed to the 4-PSK modulator at  $2 \times 1.088$  Mbd, which operates at an intermediate frequency (IF) of 70 MHz. After conversion of the modulated IF signal into the 400-MHz or 800-MHz range, amplification to 1 W or 5 W, and passage of the transmitter-receiver filter, it is radiated out via the antenna. The latter also receives at the same time in the opposite direction. Signal processing on the receiving end corresponds to that on the transmitting end, in reverse order.

At relay stations, the digital signal to be transmitted is switched through on the basic signal level at 2.176 Mbit/s in NRZ code between the receiver and following transmitter. The service channel, remote monitoring channel, and externally usable digital auxiliary channels are accessible at these stations.

There are special circuits with a high degree of integration for processing the basic signal on the transmitting and receiving ends.

For code conversion between HDB3 and NRZ and bit rate conversion between 2.048 and 2.176 Mbit/s, the

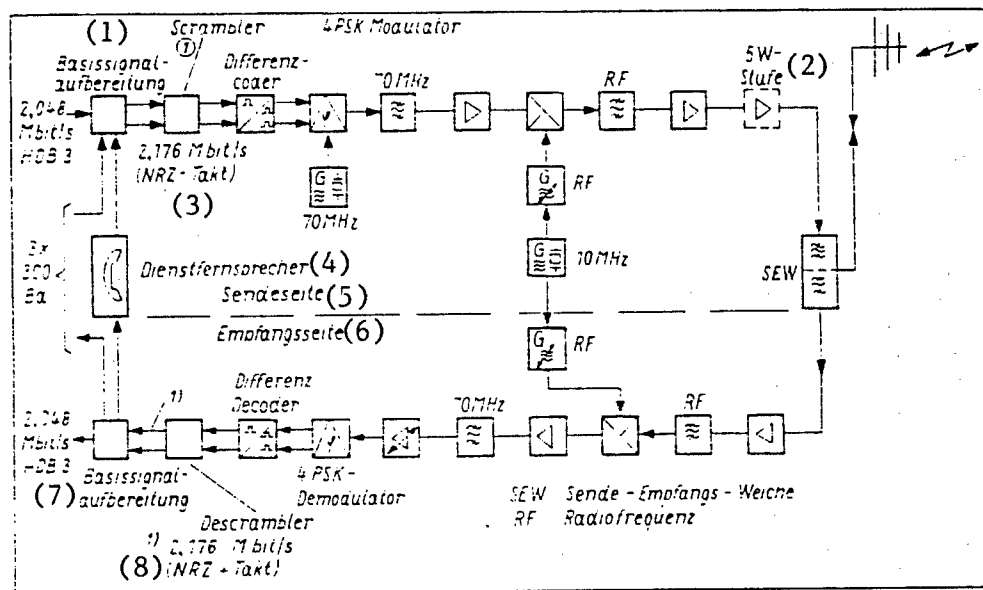

Figure 3. PCM 30-400/800 radio relay system, complete circuit diagram for a terminal station

Key:

- |                            |   |
|----------------------------|---|
| 1. Basic signal processing | 5. Transmitting end   |
| 2. 5 W stage               | 6. Receiving end  |
| 3. NRZ - clock             | 7. Basic signal processing  |
| 4. Service telephone       | 8. NRZ + clock SEW Transmitter-receiver filter RF Radio frequency |

PCM-30 receiver circuit U 1503 (CMOS) by VEB Combine Communication Electronics (KNE) is used. The voltage-controlled oscillators needed for bit rate conversion with PLL, as well as the amplifier at the HDB3 output, are realized with thick-film hybrid circuits in multilayer-multichip technology.

Conversion of the analog service channel voice signals into PCM signals and vice versa is performed with the U 1011 single-channel codec in conjunction with monolithic U 1001 LF filters. For the extensive digital functions of auxiliary signal insertion and removal, a special CMOS gate-array circuit based on the U 5200 system was developed. Other HIS are foreseen for scrambling and difference coding, for clock recovery after 4-PSK demodulation, and for difference decoding and descrambling. The IF components are also built with unit-specific thick-film hybrid circuits. Thin-film circuits, among other things, are used on the radio-frequency level.

Potential Applications

Potential applications for the PCM 30-400/800 digital radio relay system are found primarily in rural telephone systems and in special networks. However, it also has potential in establishing transmission paths in pure data networks and for mixed data and telephone transmission. The PCM 30-400/800 system is suitable for connecting network spurs in sparsely populated areas to an existing rural telephone network. The example depicted in Figure 4 shows how an OZ 100 D digital exchange (by

VEB KNE) is connected to a higher exchange with PCM-30 radio relay both directly and also by way of a branch station of a higher-channel PCM line. The figure also depicts the connection of distant exclusive telephone subscribers to an automatic circuit exchange via PCM-30 radio relay, whereby corresponding primary and branch multiplexers are necessary.

With the OZ 100 D and other digital exchanges, connections for digital trunk groups of 30 connecting channels can be linked via the 2.048-Mbit/s interface according to CCITT-Rec. G. 703 directly to a PCM-30 radio relay terminal (Figure 5). For an electromechanical exchange, a primary multiplexer with signal mark converters would be inserted in this case.

One case that can be expected in linking network spurs to a higher-channel line is the branching off of a 30-channel trunk group in PCM-120 radio relay station using secondary multiplexers and its further transmission with PCM-30 radio relay (Figure 6).

In the event of branching off from a Robotron PCM 120-2000 radio relay line, the connection of the service channel and remote monitoring of the branch line to that of the main line is guaranteed. Figure 7 shows an example of how distant subscribers can be fed to a telephone and a data switching exchange by way of PCM 30-400/800. For connecting data terminals and serving subscriber connections to the data switching exchange, Robotron will make special equipment available which

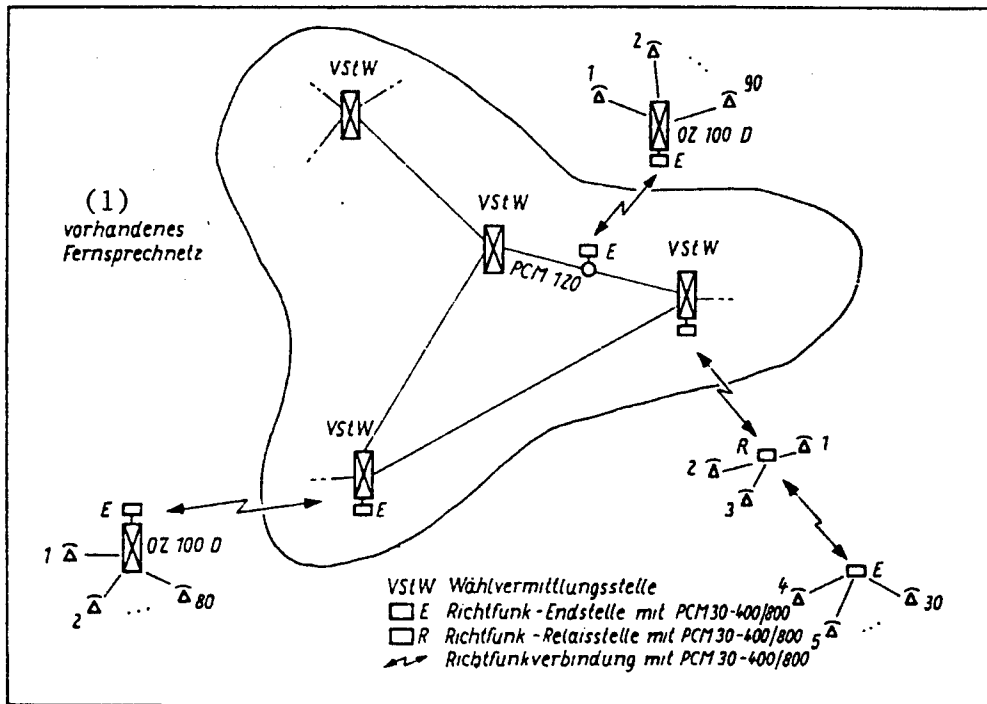

Figure 4. Connecting network spurs to an existing rural telephone network with PCM 30-400/800 (example)

Key:

- 1. Existing telephone network
- VStW Automatic circuit exchange
- E Radio terminal station with PCM 30-400/800

- R Radio relay station with PCM 30-400/800
- Arrow Radio relay connection with PCM 30-400/800

permits direct digital entry by data signals from 50 bd to 48 kbit/s into the 64-kbit/s channels of the multiplexer. In this way, all the types of interfaces recommended by CCITT in this regard (V.24, X.24) can be realized.

Generally, cellular mobile telephone networks consist of several base stations that must be connected to a transfer

station by way of 2.048-Mbit/s radio relay paths. Radio relay links with PCM 30-400/800 as the base station feeder are possible for such networks (Figure 8). With cellular mobile telephone networks that function at 16 kbit/s for voice transmission, such feeder links would be especially effective because of the resulting capacity of 120 voice channels.

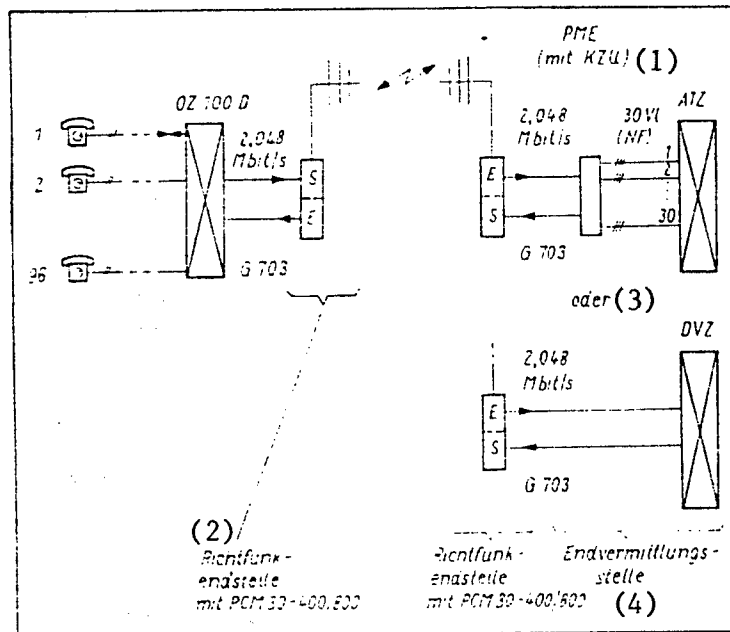

Figure 5. PCM 30-400/800 as transmission path between two telephone exchanges (example)

Key:

1. 1. PME (with KZU)
2. Radio relay terminal station with PCM 30-400/800
3. Or
4. Terminal exchange station

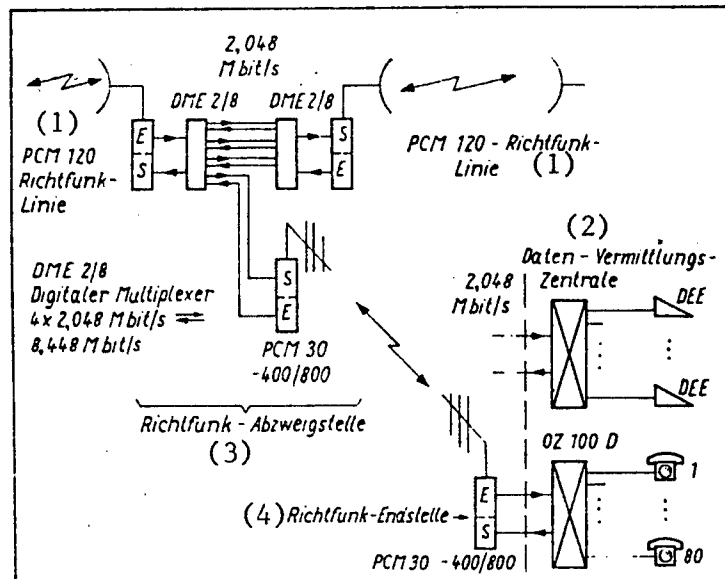

Figure 6. PCM 30-400/800 as transmission path for network spurs in telephone and data networks (example)

Key:

1. PCM 120 radio relay line
2. Data exchange station
3. Radio relay branching station
4. Radio relay terminal station



## TELECOMMUNICATIONS R&D

### Analog Transmission Systems of Czechoslovak Telecommunications Network Described

90CW0018A Prague TELEKOMUNIKACE  
(supplement) in Czech No 9, Sep 89 pp 1-8

[Article by Eng Miroslav Komarek, Research Institute of Communications, Prague: "The Analog Transmission Systems in the Czechoslovak Telecommunications Network. Part 1"]

[Text] In the color supplement, we shall publish a serialized overview of the analog transmission systems used in the Czechoslovak telecommunications network. The goal is to make it easier for readers to become oriented with regard to the current status and outlook of transmission systems, to list their basic operating technical characteristics, and to provide an overview of the parameters thus created, that is to say, of the channels and group tracts. We would like to provide the reader in this way with overview information based on regulations, programs, and standards in the knowledge that analog transmission systems will, for many years to come, continue to be the backbone of the Czechoslovak network and that such care must be devoted to their operation and maintenance as to make them conform with international recommendations or standards.

### Current Status and Outlook of Transmission Systems in the Telecommunications Network of the Czechoslovak Socialist Republic

The anticipated expansion of the telephone network by the year 2000 must be accompanied by appropriate growth in the capacities of communications and transmission systems. If there are currently 25 telephone subscriber stations per 100 inhabitants, in the year 2000 it is anticipated there will be 35 subscriber stations per 100 inhabitants. This number represents a cumulative total of about 5.5-6 million subscriber stations, of which 2.5-2.9 million will be residential (approximately 50 percent of the expected volume of residential telephone development will be achieved this way). There will be about 3 million principal and secondary stations in the socialist sector. It is expected that the annual number of long-distance calls per main subscriber station will rise from the current 180 to 300-350 which, even if the number of long-distance circuits is increased over the next few years to 120,000, will increase the average load on long-distance circuits from 0.25 erlang to 0.3-0.35 erlang.

Within the current long-distance telephone network, circuits realized in their transmission component through analog transmission systems dominate. To a considerable extent, Nf circuits are operated in junction networks. They are inexpensive and reliable. At higher network levels (transit or intertransit), they occur on "in-house" and "foreign" cross-bar junctions in transit traffic rarely or they are supplanted by vf transmission

systems as a result of capital construction by both long-distance cables administrations involved.

The telephone transmission system is divided into systems with frequency-divided channels (FDM systems—Frequency Division Multiplex) and into systems having time-divided channels (TDM systems—Time Division Multiplex). In FDM systems, each channel occupies a certain position in the line band; in TDM systems, the line band is systematically allocated to individual channels.

If we disregard several tens of digital systems of the first degree, having PCM modulation for cable operations, which are represented by TESLA equipment (KPK32, MPK32, and MPK32k systems) and Polish TCK30 systems (in conjunction with the introduction of the E10 system in local central operation) and several KPR32 and MPK32k systems using the 11AP32 link for radio-relay operation, then we see that currently only FDM systems are in operation. Despite the fact that the world trend in telecommunications networks is characterized by an energetic changeover to digital transmission and the processing of signals, analog transmission systems will retain their dominant position at least through the year 2000 in the Czechoslovak long-distance telephone network. We cannot overlook the fact that in the 1970's and 1980's considerable funds were expended to develop analog systems, particularly those of the Hungarian "BK" series and the German "V" series, that transit central offices were primarily equipped with ARM systems and with many PK202 and MK611 central systems.

The expansion of telematic services (telematic = telecommunications + informatics), the sharp expansion of the production of optic cables for light-conducting transmission systems, the development of electronic digital facilities having time-communications fields and digital muldexes of the first through fourth series with PCM modulation, all facilitate an acceleration in the process of digitizing communications networks in the telecommunications of advanced countries. Because, in such a network, transmission and communications functions are integrated on the basis of individual digital signals with a transmission speed of 64 kbits/s, we speak of an IDN (Integrated Digital Network). Because such a network makes it possible to utilize the same digital transmission paths to realize various telecommunications services, a truly unique digital network with integrated services—an ISDN (Integrated Services Digital Network), comes into being.

The Czechoslovak Communications Administration and Czechoslovak industry, in cooperation with the communications administrations and industries of the other CEMA countries, are creating the prerequisites for the gradual rebuilding of the analog telecommunications network into an integrated digital network. The concept for rebuilding the network was approved as early as 1987 and was issued as a binding industrywide technical regulation, "TA102—Planning and Design Preparation for the Expansion of the Telecommunications Network

in the Czechoslovak Socialist Republic. Part IV. Main Principles for Rebuilding the Czechoslovak Analog Telecommunications Network Into an Integrated Digital Network."

It is anticipated, after 1990, the comprehensive digitalization of selected UTO's [central telephone circuit] by the full application of PCM systems to metallic and optical cables, together with the expansion of electronic centrals having time-communications fields, will be initiated. The suitable concentration of digitized UTO's in selected TTO's [telephone and telecommunications circuits] will make it possible, in the ensuing stage, to undertake the comprehensive digitalization of these TTO's. Because the necessary capacity of transmission paths in transit and intertransit traffic can only be assured by digital systems of the second or higher level, which, in view of the significantly broader transmission band can only be applied to XV-type cables, to coaxial cables and optical cables, and in view of the fact that existing coaxial and high-frequency symmetrical cables are utilized by FDM systems, the digital systems will use either newly laid optical cables, radio-relay systems, or existing XV-type cables and coaxial cables during the reconstruction phase. Consequently, a relatively long period of coexistence between analog and digital networks is unavoidable. The integration of the scientific-research base, of the developmental and production base contributes to accelerating the entire process of digitizing the communications network in Czechoslovakia and in the remaining CEMA countries. A program for the development of production of unified systems of digital information transmission (JSPDPI) and a program for optical systems (JSOPPI) was agreed upon, within the framework of which solutions are being sought both with respect to terminal equipment, and also line tracts and measuring equipment for digital systems of the first through fourth series with PCM modulation. Cooperation in the development and production of electronic digital centrals is solved through a program covering the unified system of communications technology devices (JSPST).

An IDN or ISDN network, this is the future of Czechoslovak communications. The present telecommunications system belongs to analog systems.

The principle of analog transmission systems (the term "carrier systems" is also used or systems with amplitude modulation) is the amplitude modulation of the carrier signal through signals in the band of the telephone channel (or signals in the PG band, the SG band, etc.). Since, following amplitude modulation, individual telephone channels or groups of channels occupy varying frequency positions, they are also called multiple telephone systems with frequency division.

Of the possible methods for transmitting carrier frequencies and auxiliary bands, 12-channel and multiple-channel systems having a frequency separation of 4 kHz make exclusive use of the transmission of a single side band.

Depending on the number of lines and the position of the frequency bands which handle traffic in both directions, we differentiate between two-wire same-band operations, two-wire different-band operations, four-wire different-band operations, and four-wire same-band operations. In the DTS system, the most widespread operation is the four-wire same-band operation, which is utilized for vf symmetric cables and rr routes.

Depending on the capacity of the system, carrier equipment contains installations which provide channel, primary, secondary, tertiary, and quarternary modulation, as well as systems modulation.

In order for carrier equipment produced by various manufacturers to be compatible, in conjunction with the requirements of the CCITT, the frequency bands of basic groups and the frequencies which control the group signals are precisely defined (Fig. 1). However, Recommendation G.241 of the CCITT lists a sizable number of group control signals. Their frequencies (including permissible deviations) and the nominal absolute levels of output at the location of the relative null level are given in Table 1.

**Table 1.**  
**Frequencies and the Level of Basic Group Control Signals**

Basic Group	Frequencies of Basic Group Control Signals (Hz)	Absolute Level of Output at Location of Relative Null Level (dBmO)
Primary	84,080+/-1	-20
	84,140+/-3	-25
	104,080+/-1	-20
Secondary	411,860+/-2	-25
	411,920+/-1	-20
	547,920+/-1	-20
Tertiary	1,552,000+/-2	-20
Quaternary	11,098,000+/-10	-20
15 SG—set No 1	1,552,000+/-2	-20

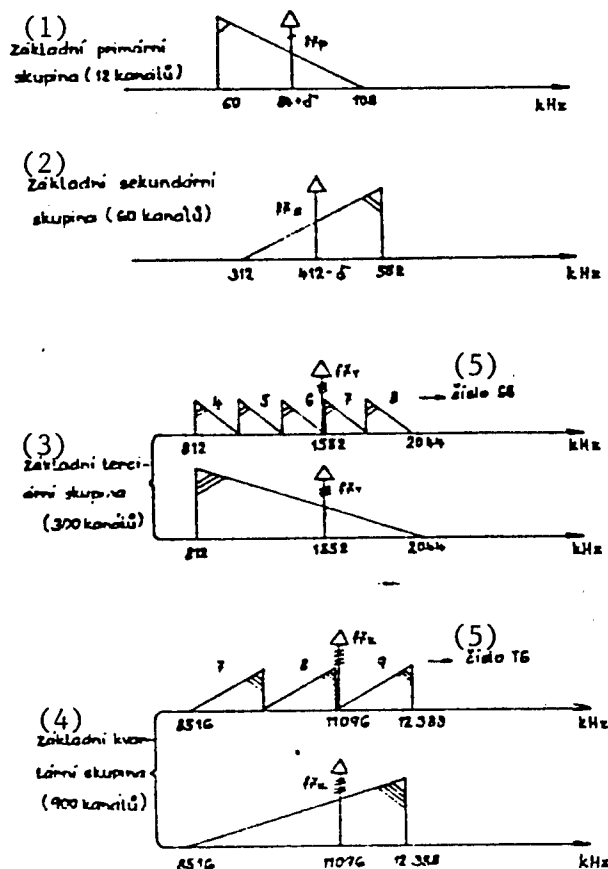

Figure 1. Frequency bands of basic primary, secondary, tertiary, and quaternary groups and appropriate group frequency control signals.

Key:—1. Basic primary group (12 channels)—2. Basic secondary group (60 channels)—3. Basic tertiary group (300 channels)—4. Basic quaternary group (900 channels)—5. Number.

signal of 411.86 kHz and 411.92 kHz are to be transmitted simultaneously. Following agreement between participating communications directorates, it is possible, for purposes of international communications, to transmit only one control signal for a group, for example,  $fr_{PG} = 84.08$  kHz and  $fr_{SG} = 411.92$  kHz. The above couple of control signals are currently used in the Czechoslovak telephone system. If, however, the PG or SG signal is used as a broad-band channel for the transmission of data (or in realization of other telematic services), the control signals  $fr_{PG} = 104.08$  kHz and  $fr_{SG} = 547.92$  kHz must also be transmitted and located near the upper margin of the band of the appropriate groups (to meet the requirement for the quality of damping characteristics required by a broad-band channel).

In order for the group tracts (PG, SG, etc.) to be able to be transited (switched through) at the appropriate interfaces (an interface is considered to be the appropriate vf distribution frame of a group) in creating national or international tracts composed of many sectors, the Recommendation G.233 of the CCITT establishes the following parameters (and the Czechoslovak standard CSN 36 6710\* standardizes them): the frequency band, the relative level of output at the input and output terminals, and the level of impedance. These values are listed in Table 2.

For example, the primary group control signal of 84.08 kHz and 84.14 kHz and the secondary group control

Table 2. Parameters at the Interface of Group Tracts

Basic Group	Number of Channels	Frequency Band (kHz)	Relative Level of Output (dBr)		Impedance ( $\Omega$ )
			Input	Output	
Primary	12	60-108	-36	-23 or -30	150 symmetrical
Secondary	60	312-552	-36	-23 or -30	75 asymmetrical
Tertiary	300	812-2044	-36	-23	75 asymmetrical
Quaternary	900	8516-12388	-33	-25	75 asymmetrical
15 SG—set No 1	900	312-4028	-33	-25 or -33*	75 asymmetrical
15 SG—set No 3	900	8620-12336	-33	-25 or -33*	75 asymmetrical

Note:

1) Values marked with an asterisk (\*) apply only in the international network of the CEMA countries.

2) The values shown in bold print are priority values.

In order to be able to mutually interlink various line tracts or in order to be able to attach line tracts to various terminal or radio-relay equipment, the appropriate interfaces (line distribution frames or their equivalent devices) with similar

parameters to those governing group tracts are established by Recommendations G.213 and G.423 of the CCITT and standardized by Czechoslovak standard CSN 36 6710\*. These values are listed in Table 3.

Table 3. Parameters of Line Tract Interfaces

Type of Systems	Number of Channels	Frequency Band (kHz)	Relative Level of Output		Impedance ( $\Omega$ )
			Input Port (T)	Output Port (T)	
1 SG (5 PG)	60	12-252	-36 (-14*, +2*)	-23 (-14*, +2*)	150 symmetrical
2 SG	120	12-552	-36 (-14*, +2*)	-23 (-14*, +2*)	150 symmetrical
1.3 MHz	300	60-1300	-36	-23	75 asymmetrical
300 + 300	300	312-1548	-33	-33	75 asymmetrical
4 MHz	900	312-4028 or 316-4188	-33 (-36)	-33 (-23)	75 asymmetrical
4 MHz	960	60-4028	-33 (-36, -20*)	-33 (-23, -48*)	75 asymmetrical
8 MHz	1800	312-8120	-33	-33	75 asymmetrical
8 MHz	1920	312-8524	-33	-33	75 asymmetrical
12 MHz	2700	312-12336 or 312-12388 or 316-12388	-33	-33	75 asymmetrical
60 MHz	10800	4332-59684 or 4404-59580	-33	-33	75 asymmetrical

Note:

1) Values marked with an asterisk (\*) apply only in the international network of the CEMA countries.

2) The values shown in bold print are priority values.

Values for line control signals, including signals controlling frequency stability and the absolute level of

output at the location of the relative null level are listed in Table 4.

Table 4. Frequencies and Levels of Line Control Signals

Carrier System	CCITT Recommendation	Frequency Band (kHz)	Line Control Frequencies (kHz)	Frequency Stability	$L_m$ Level (dBmO)
"12 + 12"	G.325	6-108	54; 60	+/-1	-15
5 primary groups	G.322	12-252	60	+/-1	-15
			256		
			1364		
1.3 MHz	G.341	60-1300	60	+/-1.10 <sup>-5</sup>	-10
			308		
			4092, 4287		
4 MHz	G.343	60-4028	60	+/-1.10 <sup>-5</sup>	-10
			308		
			4287		
8 MHz	—	312-8120	308	+/-1.10 <sup>-5</sup>	-10
			12435		
12 MHz	G.332	312-12336	4287	+/-1.10 <sup>-5</sup>	-10
			308		

The block diagram to define input and output points of line tracts is listed in Fig. 2.

The Czechoslovak Unified Telecommunications System (JTS) operates a broad assortment of carrier systems. If we disregard isolated items of equipment, the following systems are in operation in the low-frequency symmetric DM-type cable system: the KNK6 (KNK6SM, KNK6S, and KNK6T), KNK12, BK12-3, BK12-4, and the BK300/N. Of all the listed systems, it is only possible to

consider the BK300/N as having any future prospects; the KNK12 system will be retained for a long time to come; the remaining systems (particularly the obsolete KNK6 system) are being replaced by both of the involved communications directorates in capital construction with digital transmission systems in conjunction with the concept calling for the systematic rebuilding of the analog network into an integrated digital network. High-frequency symmetric XV cables are used in the operation of BK60-3 systems particularly

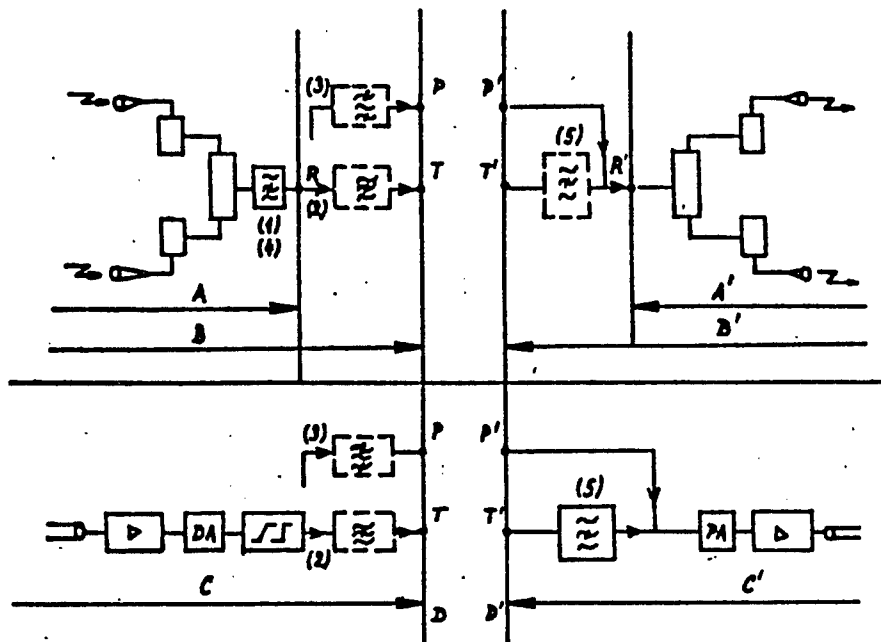

Figure 2. Definition of input and output points of a line tract (T', T).

Key:—A, A—Radio-relay system—B, B—Line tract of radio-relay system—C, C—Line tract of cable system—D, D—Limits of vf line equipment—P, P'—Output, input of radio-relay system—R, R'—Positions for off-taking and introducing line control frequencies—T, T—Input, output ports of line tract (locations for attaching terminal equipment or connecting to another line tract)—PA, DA—Premodulation and demodulation phase—(1), (4)—Line control frequency band filter or filter for control or monitoring signals—(2), (5)—Suppression filter for unwanted signals from the line tract—(3)—Control signal band filter or transit filter for standardized channel group.

(in the "national circuit") and the ULT120 system (in the communications tract linking the socialist countries). Coaxial cables are used particularly for the BK300/960, the BK2700, the VLT1800/1920 systems, and the obsolete K300 system.

All of the above carrier systems result in the following capacities at the disposal of the Czechoslovak Unified Telecommunications System: 12 channels (system "n + n"), 60 channels, 120 channels, 300 channels (system "n + n"), 300 channels (system 1.3 MHz), 900/960 channels (system 4 MHz), 1800/1920 channels (system 8 MHz), and 2700 channels (system 12 MHz).

In the Czechoslovak Unified Telecommunications System, the following are recommended out of the possible frequency plans:

- for "12 + 12" systems using symmetrical pairs—schematic 2 (Fig. 3);
- for systems with 5 PG using symmetrical pairs—schematic 2 or possibly 2 bis (for use in international communications following agreement between participating administrations)—Fig. 4;
- for 1.3-MHz systems using coaxial pairs of 1.2/4.4—plan "a" (Fig. 5);
- for 4-MHz systems using coaxial pairs of 1.2/4.4—plan "1" (Fig. 6);

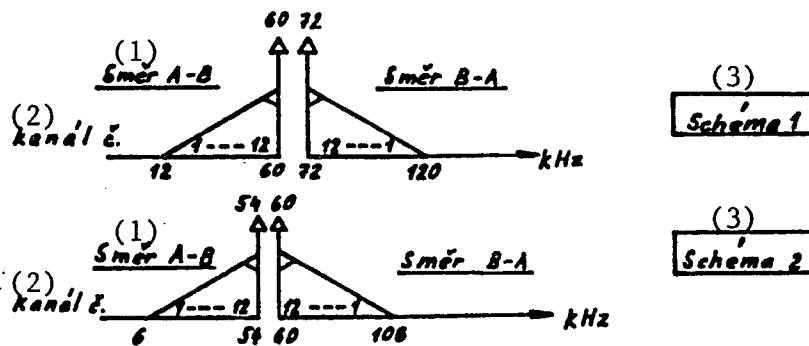

Figure 3. Arrangement of line frequencies for "12 + 12" systems using nf noncoiled pairs of DM cables. Key:—1. Direction—2. Channel—3. Schematic.

- for 8-MHz systems using coaxial pairs of 2.8/9.5, the frequency plan is derived from plan "2" of the 12-MHz system (Fig. 7);
- for the 12-MHz system using coaxial pairs of 2.6/9.5—plan "2" (Fig. 8).

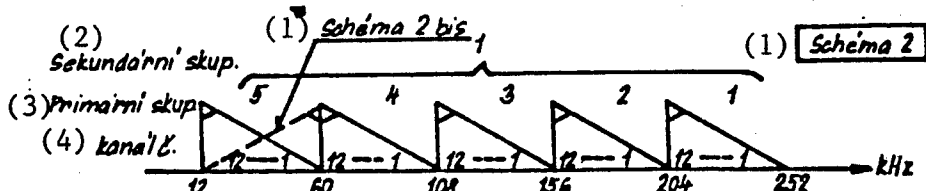

Figure 4. Arrangement of line frequencies for 60-channel carrier frequency telephone systems.  
Key:—1. Schematic—2. Secondary group—3. Primary group—4. Channel number.

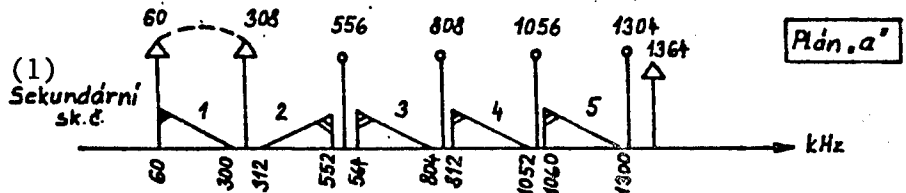

Figure 5. Arrangement of line frequencies involved in the 1.3-MHz system for small coaxial cables—variations involving five secondary groups.  
Key:—1. Secondary group number.

The predominant portion of the operational load in the

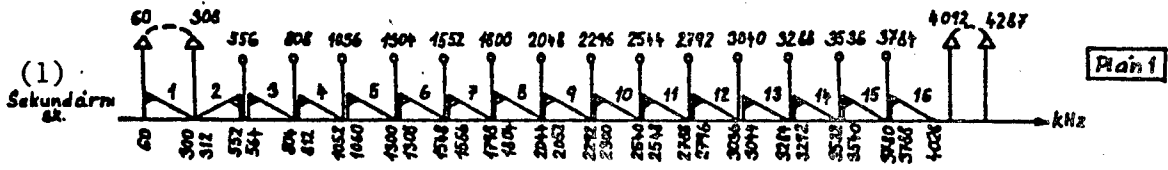

Figure 6. Arrangement of line frequencies involved in the 4-MHz system for small coaxial cables—variation involving 16 secondary groups.  
Key:—1. Secondary group.

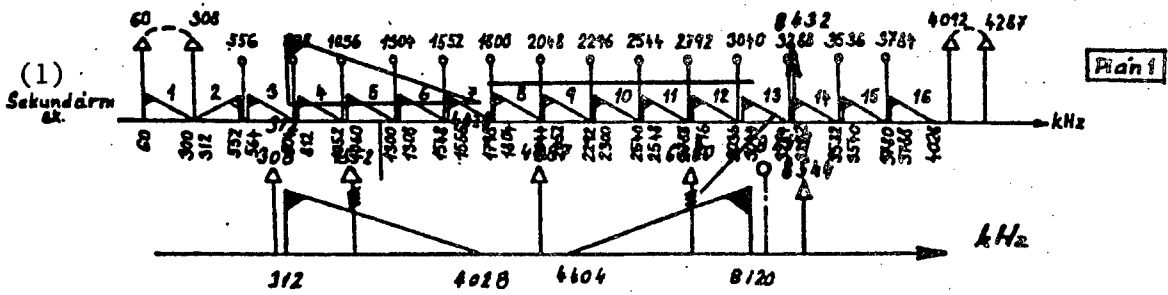

Figure 7. Arrangement of line frequencies for the 8-MHz system.

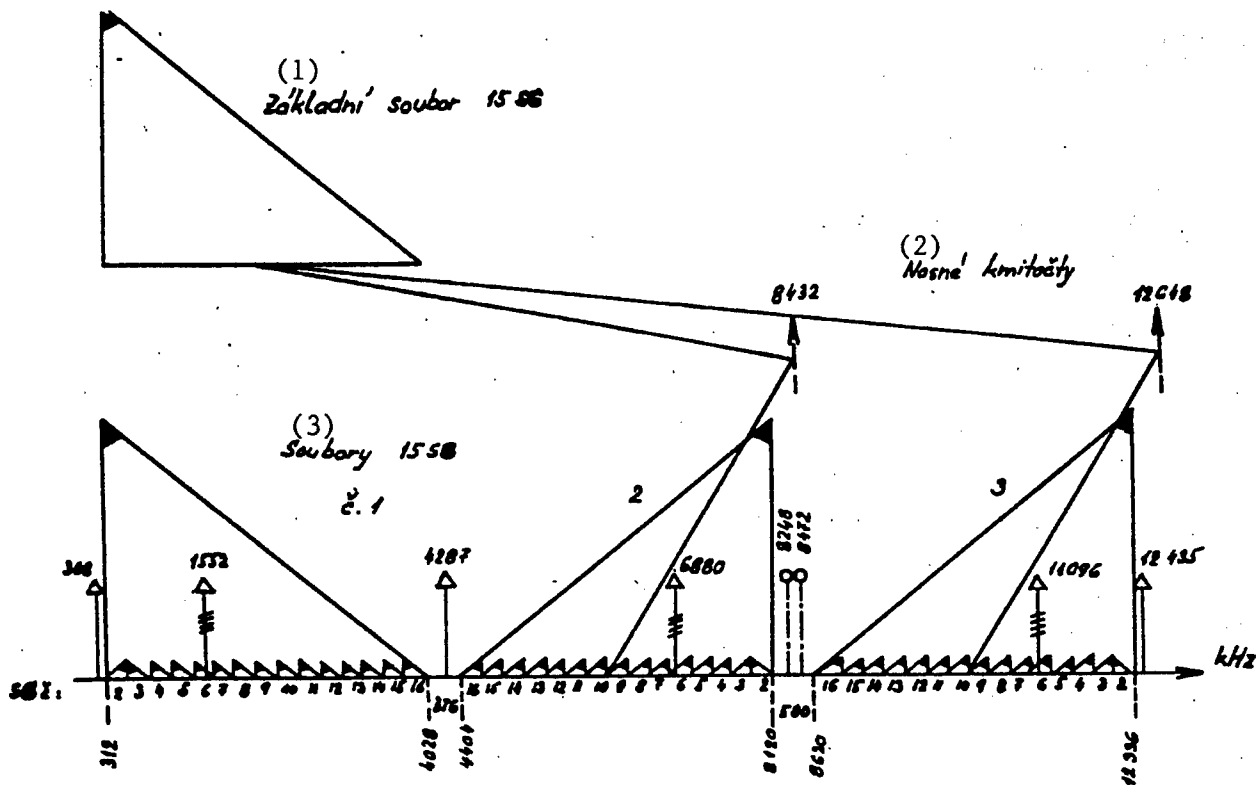

Figure 8. Arrangement of line frequencies for the 12-MHz system.

Key:—1. Basic set—2. Carrier frequencies—3. Sets.

current analog telecommunications network is handled along transmission pathways which are equipped (depending on the level of the network) with KNK12, BK300/N, BK60-3, BK300/960, BK2700, and VLT1800/1920 carrier systems. This is also why these systems are the subject of appropriate attention, both by controlling units involved in the technical operation of the Communications Administration in Prague and the Telecommunications Administration in Bratislava, as well as by managing and executive components involved in operation and maintenance at individual enterprises—regional administrations responsible for long-distance cables. Reliable operation and maintenance is also aided by sets of accompanying technical documentation, supplied by manufacturers, as well as by industrywide technical regulations governing the operation and maintenance of individual systems. To facilitate an overview regarding the individual systems, their operational technical characteristics are reviewed below.

#### Operational Technical Characteristics of Carrier Systems

##### The KNK12 Carrier System

The KNK12 carrier system (produced by Tesla-Strasnice) is intended for the transmission of 12 telephone frequency channels in single-cable multiband operation using uncoiled (decoiled) pairs of symmetric

DM cables having an average diameter of 0.9 and 1.4 mm of copper wire or 1.8 mm of aluminum wire. It is thus possible to create 12 telephone frequency circuits in 1 pair (12 telephone frequency channels at a bandwidth of 60-108 kHz in one direction, 12 telephone frequency channels in the 6-54-kHz band in the opposite direction).

The distance between two terminal stations when using a DM 0.9-mm-diameter copper cable is 82 km; when an attended relay station is used, the distance is 164 km.

The KNK12 system is composed of a terminal station and a line tract device.

##### Terminal Station

The terminal station consists of a modulation and group frame (ST6C) and a frame for forks and companders (SV6C). The SV6C frame has the character of an auxiliary frame for the KNK12 system (depending on requirements, it can but need not be set up). The ST6C frame makes possible the creation of a maximum of six 12-channel groups, that is to say, 72 four-wire circuits, complete with signal channel. It contains a frame power source, a source of carrier frequencies, a power source for amplifying relay stations, an nf and vf attachment field, and a measuring field. Its frequency plan is contained in Fig. 10—schematic 2. The basic primary group

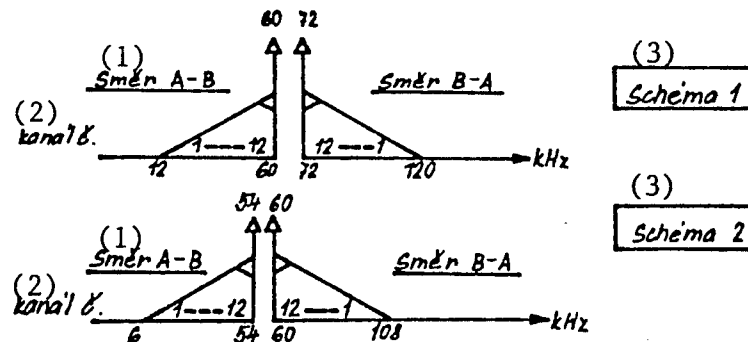

Figure 10. Arrangement of line frequencies for the "12 + 12" system using uncoiled pairs of DM cables.

Key:—1. Direction—2. Channel number—3. Schematic.

A is obtained by modulating the primary carrier frequency of 114 kHz with the basic B group.

The modulating equipment of the ST6C frame contains the channel and group units.

Because the KNK12 facilitates two-wire different-frequency operation, we differentiate between type "A" and "B" stations in the manner shown in Table 5.

Table 5.  
Line Bands and Control Signals for Type A and Type B Stations of the KNK12 System

Station	Direction of Operation	Line Band (kHz)	Frequencies of Line Control Signals
A	Transmission	6-54	54
	Reception	60-108	60
B	Transmission	60-108	60
	Reception	6-54	54

#### Overview of Basic Electrical Parameters of Terminal Station

Voice Channel	
Frequency band	(300-3400) Hz
Nominal input level	-13 dBr
Nominal output level	+4 dBr
Extent of output level regulation (continuous)	7 dB
Priority setting level	+/-0.2 dB
Input and output impedance	600 Ω
Signal Channels	
Nominal frequency	3825 Hz
Nominal level	-20 dBmO +/-0.4 dB
Range of continuous regulation	1.7 dB
Vf Side of Channel Modulation	
Frequency band	(60-108) kHz
Nominal output level (may be changed by resoldering)	-36.5; -39; -35.6 dB/150 Ω; -39 dB/135 Ω
Nominal input level (may be changed by resoldering)	-30.4; -5.2; -22.6 dB/150 Ω; -5.2 dB/135 Ω
Group Unit	
At the interface with channel modulation, nominal input level (point TB-V)	-36.5; -39; -35.6 dB/150 Ω
Nominal output level (TB-P)	-30.4; -5.2; -22.6 dB/150 Ω 12.6+/-0.44 dB/150 Ω
Input level at frequency of 108 kHz	-45 dB/150 Ω

## Automatic Regulation of Levels

### Primary Group

The frequencies and levels of control signals for the primary group are 84.08 kHz (-20 dBmO)—automatic regulation, 84.14 kHz (-25.2 dBmO)—without automatic regulation.

Note on automatic regulation:

1. If the input deviation level does not exceed the nominal value of 3.5 dB, then the output deviation level will not exceed the nominal value of 0.44 dB.
2. A defect is signaled if the deviation of the input level ranges between 3.5 dB and 7 dB of the nominal values.
3. If the input level deviation exceeds 7 dB, the transmitters of all 12 channels of the appropriate PG are blocked in the busy position.

### Line Tract

The frequency and level of the line tract control signal is 60 kHz (-15 dBmO).

Note on automatic regulation:

If the deviation of the noise level exceeds the nominal value of 3.5 dB, a defect is signaled.

### Line Tract Installation

The installation for the line tract consists of a frame of attended STZ-C amplifiers and of untended PZS-6C relay amplifying stations.

A rack of STZ-C attended amplifiers is designed in the following cases:

- where the number of untended PZS-6C stations between terminal stations is greater than eight (each attended station can provide a remote power source for a maximum of four untended amplifying stations);
- where a change is being made from one type of cable to another;
- where there is a requirement to provide a PG junction on the route;
- where unsuitable damping distortion exists.

In the STZ-C, there is always an inversion of the band of every PG, from 6-54 kHz to 60-108 kHz and vice versa, and the signal in both directions of transmission is always strengthened.

An untended PZS-6C relay station increases the signal in both directions of transmission. It is possible to install three sets of SZC-2 amplifier units into the housing of this PZS with each set strengthening the signals of two PG's in both directions for a maximum gain of 30.5 dB at a frequency of 108 kHz.

The maximum length of the amplifying sector also depends on the maximum gain achieved by the amplifiers and the

attenuation of the cable used. This maximum distance is 9.15 km for cable of the DM type having an 0.9-mm copper core.

### Service Communication, Telemechanics, and Remote Power Feed for the PZS

Service communications between any basic stations along the line tract of a KNK12 system is accomplished by an SLS loud service set which is connected to the common circuit of any DM quad cable, utilized in the operation of the KNK12 system.

Long-distance monitoring of the KNK12 system is restricted only to the localization of a defective amplifier, provided long-distance power feeds have not been disrupted (DN). By changing the polarity within the DN installation at the OZS, localizing oscillators are simultaneously activated, oscillators which are mounted in the SZC-2 units of individual PZS facilities patched into the appropriate DN loop. The oscillator-transmitted frequencies are evaluated in the terminal stations of the system.

The PZS facilities are fed power remotely from the ST6C frame or from the STZ-C frame along a combined circuit of the vf quad cable. In other words, the ST6C frame can be used to feed power in three different directions (each time using one quad cable), to a maximum of four organic PZS facilities. The STZ-C frame, to which it is possible to attach a maximum of 12 quad cables, can be used to provide remote power feeds in 12 different directions (using 1 quad cable each time), to a maximum of 4 organic PZS facilities. Long-distance power feeding is accomplished with direct current at 23 mA +/-3 percent, derived from a constant power source.

### The BK300/N Carrier System

The BK300/N carrier system (produced by the Telefongyar Enterprise of the Hungarian People's Republic) is intended for the transmission of 300 telephone channels in single-cable four-wire different-frequency operation over uncoiled (decoiled) pairs of symmetric nf DM cables with 0.9-mm-diameter copper wire cores and a capacity of 38.5 nF/km.

In other words, it is possible to utilize two pairs of various DM quad cables to create 300 telephone circuits (300 telephone channels in a frequency band ranging from 247 to 1602 kHz in one direction, 300 telephone channels in frequency bands ranging from 1811 to 3204 kHz in the opposite direction).

The bridgeable distance between two terminal stations is 70 km; if attended relay stations are used, the distance increases by 70 km with each attended station used.

The BK300/N system consists of a multiplex installation of combined KEK-300/N frames for a terminal or a relay amplifier station, it has NBK300/N untended relay amplifiers and auxiliary equipment (portable power sources, portable telephone service sets, crosstalk baffles, etc.).

Because the BK300/N system supports operations on a number of bands, we differentiate between "A"-type and "B"-type stations, as listed in Table 6.

**Table 6.**  
**Line Bands and Control Signals of A- and B-Type Stations of the BK300/N System**

Type of Station	Direction of Operations	Line Band (kHz)	Frequencies of Line Control Signals (kHz)
A	Transmitting	312.3-1547.7	267 and 1602
	Receiving	1923.3-3158.7	1869 and 3204
B	Transmitting	1923.3-3158.7	1869 and 3204
	Receiving	312.3-1547.7	267 and 1602

The arrangement of line frequencies for the BK300/N system is depicted in Fig. 12.

The lowest band is made up of a basic band of five secondary modulators within the range of 312.3 to 1547 kHz, augmented by line control signals at frequencies of 267 and 1602 kHz.

The upper band, within the range of 1923.3-3158.7 kHz, arises as a result of the modulation of the carrier frequency signal at 3471 kHz through the basic lower band and is augmented by line control signals at frequencies of 1869 and 3204 kHz.

It is possible to transmit a starting signal for identification oscillators at frequencies of 1575 kHz from an "A"-type station into the lower band. The frequencies of identifying oscillators lie in the frequency band 1811-1849 kHz at intervals of 1 kHz from each other. The oscillators are installed in the PZS facilities.

A 300-kHz frequency comparison signal can be introduced, from an external source, into the line frequency band both in an "A"-type station and also in a "B"-type station.

Terminal or attended stations are composed of multiplex facilities and combined KEK300/N amplifier frames. Examples of KEK300/N frame configurations at terminal stations, relay stations, and relay stations equipped with junction facilities are depicted in Fig. 13.

It is possible to locate the following in one KEK300/N frame:

- in a terminal station—units for one LT, including primary and secondary modulators, or units for two LT's without modulators;
- in a relay station—units for one relay LT.

Frequency band	Lower band	267-1602 kHz
	Upper band	1811-3204 kHz
Nominal level of transmission	Lower band	-15 dBr
	Upper band	-5 dBr
	Premodulation phase	6.5 dB
Reception	Lower band (at frequency 1602 kHz)	-42 dBr
	Upper band (at frequency 3204 kHz)	-46.5 dBr
Input and output impedances		124 Ω, symmetrical

The overview of the functional significance of the units within the BK300/N system is depicted in Fig. 13. The E2 frame design has 20 unit positions vertically (numbering is accomplished from the top downward) and some units have firmly defined positions. In the case of other units, variable positioning is permitted.

Units having a firm position:

- VTB—position 0
- BTB—position 9
- TTE—300/N—positions 8 and 10
- HB-4—position 11
- TE—positions 17-19.

#### Overview of Basic Electrical Parameters of the BK300/N System

The multiplex facility is not a direct component of the BK300/N system. Consequently, even the overview of the electrical parameters of the system begins with defined values at the muldex interface (that is to say, at the entrance to the line amplifier unit and at the point where group modulation begins). The basic parameters of the nf channels of the connected muldexes are standardized as a result of appropriate recommendations of the CCITT or the Organization of Cooperation of Socialist Countries in the Field of Electricity and Postal Communications.

#### Muldex Interface (Points T and T'—Input and Output of the LT)

Frequency band	312-1548 kHz
Nominal input and output levels	-33 dBr
Input and output impedance	75 Ω, asymmetrical

#### Cable Tract Interface (Input and Output of the VVB Unit on the Line Side)

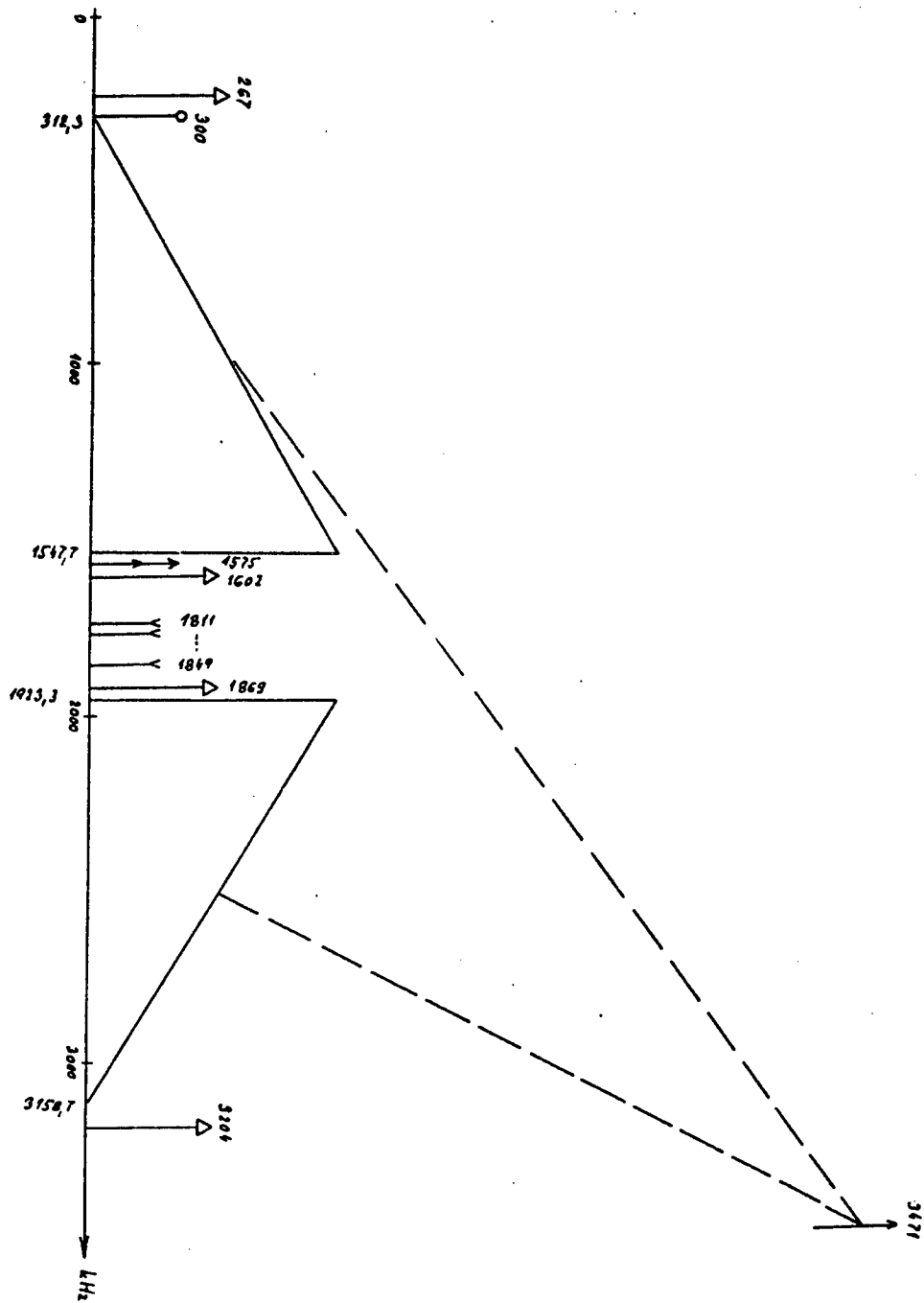

Figure 12. Arrangement of line frequencies for the BK300/N system.

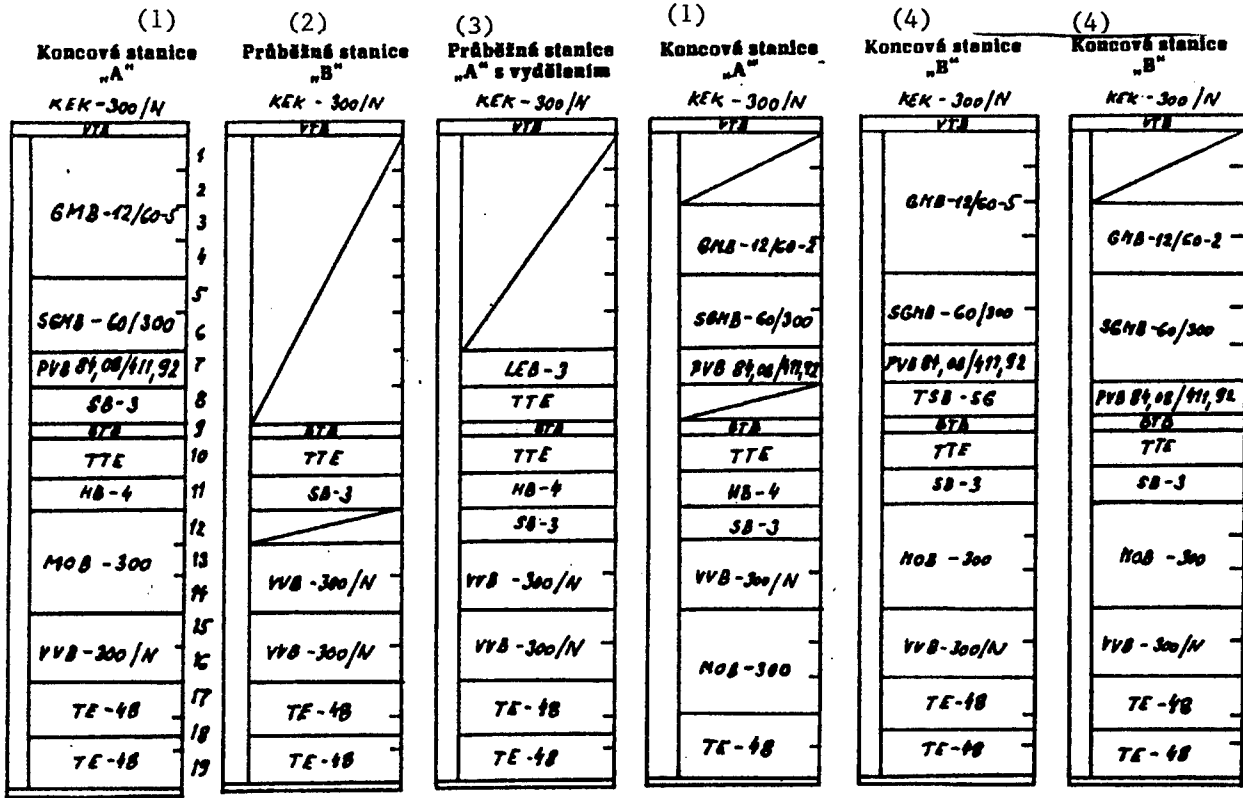

Figure 13. Examples of frame configuration.

Key:—1. "A"-type terminal station—2. "B"-type relay station—3. "A"-type relay station with separation facility—4. "B"-type terminal station;—KEK300/N—Combined amplifier frame—VVB-300/N—Unit for line amplifiers and group modulation—SGMB-60/300—Unit of secondary modulators—GMB-12/60-5—Unit of primary modulators for 5SG—GMB-12/60-2—Unit of primary modulators for 2SG—MOB-300—Basic generator unit—TSB-SG—SG transit filter unit—PVB-84.08/411.92—PS and SG control frequency receiver unit—BTB—Distribution and fuse unit—VTB—Line transformer unit—SB-3—Service communications unit—TTE—Remote power source unit—HB-4—Unit used to localize defects in the line tract—LEB-3—Separation unit—TE-48—Network power source unit.

**Line Amplifier—Level Regulation**

Gain in lower band (at frequency of 1602 kHz)		26.8 dB
Gain in upper band (at frequency of 3204 kHz)		41.5 dB
Frequencies and levels of control signals for the line tract	In the lower band	267 and 1602 kHz (-10 dBmO)
	In the upper band	1869 and 3204 kHz (-10 dBmO)
Range of regulation in lower band	Flat regulation	min +/-3 dB
	Oblique regulation	min +/-3.5 dB
Range of regulation in upper band	Flat regulation	min +/-5 dB
	Oblique regulation	min +/-3 dB
Defect signals	If the deviation of the control signal level for the line band exceeds 1.5 dB of the nominal level at the line amplifier output port, a defect signal is generated.	

**Regulation Correction of the Line Tract**

The following correction devices are installed in attended amplifier stations:

- a corrector to set the nominal values of cable attenuation for nominal cable lengths of 1800+/-30 m within the range of the transmitted line band 267-3204 kHz; it is possible to correct a maximum of 6 percent of the deviation of attenuation from nominal values;
- a permanent corrector for systems deviations of attenuation between two attended stations;
- a cable supplement to equalize a shortened amplifying sector by extending it to nominal lengths;
- a corrector to handle the attenuation distortion present in station cables;
- an automatic level regulator for two control signals in the upper band (1869 and 3204 kHz) and for two control signals in the lower band (267 and 1602 kHz).

10

22161

31

NTIS  
ATTN: PROCESS 103  
5285 PORT ROYAL RD  
SPRINGFIELD, VA

22161

This is a U.S. Government publication. Its contents in no way represent the policies, views, or attitudes of the U.S. Government. Users of this publication may cite FBIS or JPRS provided they do so in a manner clearly identifying them as the secondary source.

Foreign Broadcast Information Service (FBIS) and Joint Publications Research Service (JPRS) publications contain political, economic, military, and sociological news, commentary, and other information, as well as scientific and technical data and reports. All information has been obtained from foreign radio and television broadcasts, news agency transmissions, newspapers, books, and periodicals. Items generally are processed from the first or best available source; it should not be inferred that they have been disseminated only in the medium, in the language, or to the area indicated. Items from foreign language sources are translated; those from English-language sources are transcribed, with personal and place names rendered in accordance with FBIS transliteration style.

Headlines, editorial reports, and material enclosed in brackets [ ] are supplied by FBIS/JPRS. Processing indicators such as [Text] or [Excerpts] in the first line of each item indicate how the information was processed from the original. Unfamiliar names rendered phonetically are enclosed in parentheses. Words or names preceded by a question mark and enclosed in parentheses were not clear from the original source but have been supplied as appropriate to the context. Other unattributed parenthetical notes within the body of an item originate with the source. Times within items are as given by the source. Passages in boldface or italics are as published.

### SUBSCRIPTION/PROCUREMENT INFORMATION

The FBIS DAILY REPORT contains current news and information and is published Monday through Friday in eight volumes: China, East Europe, Soviet Union, East Asia, Near East & South Asia, Sub-Saharan Africa, Latin America, and West Europe. Supplements to the DAILY REPORTs may also be available periodically and will be distributed to regular DAILY REPORT subscribers. JPRS publications, which include approximately 50 regional, worldwide, and topical reports, generally contain less time-sensitive information and are published periodically.

Current DAILY REPORTs and JPRS publications are listed in *Government Reports Announcements* issued semimonthly by the National Technical Information Service (NTIS), 5285 Port Royal Road, Springfield, Virginia 22161 and the *Monthly Catalog of U.S. Government Publications* issued by the Superintendent of Documents, U.S. Government Printing Office, Washington, D.C. 20402.

The public may subscribe to either hardcover or microfiche versions of the DAILY REPORTs and JPRS publications through NTIS at the above address or by calling (703) 487-4630. Subscription rates will be

provided by NTIS upon request. Subscriptions are available outside the United States from NTIS or appointed foreign dealers. New subscribers should expect a 30-day delay in receipt of the first issue.

U.S. Government offices may obtain subscriptions to the DAILY REPORTs or JPRS publications (hardcover or microfiche) at no charge through their sponsoring organizations. For additional information or assistance, call FBIS, (202) 338-6735, or write to P.O. Box 2604, Washington, D.C. 20013. Department of Defense consumers are required to submit requests through appropriate command validation channels to DIA, RTS-2C, Washington, D.C. 20301. (Telephone: (202) 373-3771, Autovon: 243-3771.)

Back issues or single copies of the DAILY REPORTs and JPRS publications are not available. Both the DAILY REPORTs and the JPRS publications are on file for public reference at the Library of Congress and at many Federal Depository Libraries. Reference copies may also be seen at many public and university libraries throughout the United States.