

JPRS-EST-90-025
27 DECEMBER 1990



**FOREIGN
BROADCAST
INFORMATION
SERVICE**

JPRS Report

DECLASSIFICATION STATEMENT &
Approved for public release
Distribution Unlimited

Science & Technology

Europe

DTIC QUALITY INSPECTED 3

REPRODUCED BY
U.S. DEPARTMENT OF COMMERCE
NATIONAL TECHNICAL INFORMATION SERVICE
SPRINGFIELD, VA. 22161

19980123 084

Science & Technology Europe

JPRS-EST-90-025

CONTENTS

27 December 1990

WEST EUROPE

AEROSPACE, CIVIL AVIATION

CNES 1990 Program, Budget Outlined [Toulouse LA LETTRE DU CNES, Aug 90]	1
ESA To Participate in International Microgravity Experiment [Bonn TECHNOLOGIE-NACHRICHTEN MANAGEMENT-INFORMATIONEN, 26 Sep 90]	4
Costs Mount in European HERMES Space Program [Bonn TECHNOLOGIE-NACHRICHTEN MANAGEMENT-INFORMATIONEN, 26 Sep 90]	4
UK, Soviets Cooperate in Satellite Launch Project [Brussels EAST WEST, 24 Sep 90]	5
German Aerospace Research Institute Opens Spaceflight Centers [Bonn WISSENSCHAFT WIRTSCHAFT POLITIK, 3 Oct 90]	5
Germany: Laser Procedure Measures Hermes Re-Entry Temperatures [Frankfurt/Main FRANKFURTER ZEITUNG/BLICK DURCH DIE WIRTSCHAFT, 12 Sep 90]	6

COMPUTERS

Siemens Chief Discusses Computer Market Trends [Hermann Franz Interview; Hamburg DER SPIEGEL, 4 Sept 90]	6
Germany: New Optical Disk Computer System Described [Volker Heiner; Frankfurt/Main FRANKFURTER ZEITUNG/BLICK DURCH DIE WIRTSCHAFT, 20 Sep 90]	9
Suprenum's Financial Future Doubtful [M. Groteluschen; Duesseldorf VDI NACHRICHTEN, 3 Aug 90]	11
Germany: Potential Applications of ILPRIOS Program Reviewed [M. Herrig; East Berlin FEINGERAETETECHNIK, Jun 90]	12

ENERGY

French Firm Develops Diesel Alternative [Newbury FRANCE ALERT, 3 Oct 90]	14
--	----

FACTORY AUTOMATION, ROBOTICS

Germany: Control System for Flexibly Automated Assembly Cell Described [G. Neubert, et al.; East Berlin FERTIGUNGSTECHNIK UND BETRIEB, Aug 90]	14
Germany: Assembly Automation Using RoVis 8 Image Processing System [W. Deutsch, L. Pfeil; East Berlin FERTIGUNGSTECHNIK UND BETRIEB, Jul 90]	19

LASERS, SENSORS, OPTICS

Bremen Firm Develops Portable Laser for Ship Construction [Bernd Ladiges, Wolfgang Karsten; Duesseldorf HANDELSBLATT, 13 Sep 90]	21
Dutch Center Develops Free-Electron Laser [Rijswijk POLYTECHNISCH WEEKBLAD, 30 Aug 90]	22

MICROELECTRONICS

EC Launches Open Microprocessor Initiative [Paris ELECTRONIQUE HEBDO, 20 Sep 90]	22
JESSI Wafer-Scale Integration Project Approved [Paris ELECTRONIQUE HEBDO, 6 Sep 90]	23
Nokia Develops Flat Screen Concept [Paris ELECTRONIQUE HEBDO, 27 Sep 90]	23
Belgian IMEC Laboratory's Achievements Reviewed	25
0.25-Micron Optical Lithography [Dirk Denoyelle; Kalmthout INDUSTRIE, Oct 90]	25
0.7 Micron Chip Technology [Dirk Denoyelle; Kalmthout INDUSTRIE, Oct 90]	25

Superconducting Chips [Dirk Denoyelle; Kalmthout INDUSTRIE, Oct 90]	25
Philips France Develops 'Learning' Neural Chip [Rijswijk POLYTECHNISCH TIJDSCHRIFT, Aug 90]	25
French Labs Cooperate in Submicron Research [Paris ELECTRONIQUE HEBDO, 13 Sep 90]	26
Germany: Operation, Applications of Domestic ASIC's Described	26
U5301 FC-302 [Hartmut Korsitzky, et al.; East Berlin RADIO FERNSEHEN ELEKTRONIK, Aug 90]	26
U5301 FC-301 [Frank Seiler, Achim Seider; East Berlin RADIO FERNSEHEN ELEKTRONIK, Aug 90] ...	33
Germany: Circuit Pattern Drafting Machine Described [H. H. Finck; East Berlin FEINGERAETETECHNIK, Jun 90]	37
UK: Organic Semiconductors Developed [Rijswijk POLYTECHNISCH TIJDSCHRIFT, Oct 90]	41
UK: Sinclair Designs Fast Parallel Chip [Brussels INDUSTRIE, Sep 90]	41

SCIENCE & TECHNOLOGY POLICY

EUREKA Assessment Panel Established [Amsterdam COMPUTABLE, 6 Jul 90]	41
Evaluation of EUREKA Planned [Amsterdam COMPUTABLE, 8 Jun 90]	42
Improved Links Between FRG, GDR Researchers Planned [Hans-Martin Adler; East Berlin DFN MITTEILUNGEN, Jun 90]	43
Danish Research Center Reorganizes, Focuses on Environment [Jens J. Kjergaard; Copenhagen BERLINGSKE TIDENDE, 23 Jul 90]	45
Changes Planned for German Research Institutes, Academy of Sciences [Landsberg PRODUKTION, 6 Sep 90]	47
Dutch Government Increases Technology Funding [Amsterdam COMPUTABLE, 22 Jun 90]	48

SUPERCONDUCTIVITY

Netherlands: Superconducting Josephson Junction Developed [Rene Raaijmakers; Rijswijk POLYTECHNISCH WEEKBLAD, 30 Aug 90]	49
---	----

TELECOMMUNICATIONS R&D

D2-Mac on Shaky Ground as European HDTV Standard [Frankfurt/Main FRANKFURTER ZEITUNG/BLICK DURCH DIE WIRTSCHAFT, 30 Oct 90]	50
---	----

EAST EUROPE

TELECOMMUNICATIONS R&D

CSSR: Trial Operation of APRES 01, APRES 02 Telecommunications Gear [Eng Milan Kovacic, et al.; Prague TELEKOMUNIKACE, Jul 90]	52
New-Generation Digital Signal Transmission Device Described [Bogdan Czajka, Mateusz Czygrinow; Warsaw WIADOMOSCI TELEKOMUNIKACYJNE, Jul 90]	56

AEROSPACE, CIVIL AVIATION

CNES 1990 Program, Budget Outlined

91AN0043 Toulouse LA LETTRE DU CNES in French Aug 90 pp 2-6

[Text] The 1990 budget of the National Center for Space Studies (CNES), which is significantly higher than the 1989 budget, is the direct result of:

- The decisions by the EC ministers in The Hague in November 1987 on the continuation of the Ariane-5, Hermes, and Columbus programs; the start-up of the data relay satellite program; and the retrofit of the Guiana Space Center in connection with the development of Ariane-5;
- The French Government's July 1989 decision to develop the SPOT-4 satellite in conjunction with the Helios program;
- The need to sustain an adequate and regular growth of scientific research programs, both at the European level and in cooperation with the major space technology powers;
- The decisions on manned flights made by the French and Soviet heads of state in late 1988;
- The continuation of key activities in connection with research and technology plans and the preparation of future programs in order to safeguard France's leading position both in proposing and conducting space programs.

The table below shows the breakdown of the 1990 CNES budget, all taxes included (ATI), shown by source of funding.

Funding Source	Initial 1989 Budget (ATI, in million francs)	Initial 1990 Budget (ATI, in million francs)
Government subsidy	6,453.011	7,186.929
—Program authorizations (MPTE — Chapter 83.59)	5,747.000	6,449.000
—Ordinary expenditures (MRT — Chapter 36.80)	706.011	737.929
Own funds	1,630.200	2,218.428
Total	8,083.211	9,405.357

*MPTE—Ministry of Postal Services, Telecommunications, and Space

*MRT—Ministry of Research and Technology

Note: The 1990 budget shows an increase of 16.4 percent compared to 1989.

After deduction of value-added taxes (VAT) levied on operating subsidies received from the government, the actual funds available to the CNES to cover the operations mentioned in the 1990 budget amount to 9,080.628

million French francs (Fr), as compared to Fr7,794.488 million in the initial 1988 budget, i.e., an increase of 16.5 percent.

The CNES budget (subsidies + own funds) breaks down into five major categories:

—multilateral cooperation (European programs),—bilateral cooperation,—national program,—technical and operational support of programs,—general operations.

The graphs below show the changes in these five categories between 1989 and 1990 (in millions of current francs).

European Multilateral Cooperation

The funding allocated to this category covers the French contributions to the various European Space Agency (ESA) programs: Fr3,641 million in the 1990 budget.

The scientific programs (7.5 percent) involve:

- Operational satellites, including the International Ultraviolet Explorer (IUE), the European X-Ray Observatory Satellite (Exosat), and Hipparcos (astrometrical satellite launched in August 1989);
- Projects currently under development, including the Hubble Space Telescope (placed in orbit in the spring of 1990); Ulysses (the former International Solar Polar Mission), whose launch is planned for the end of 1990; the Infrared Space Observatory (ISO); SOHO (solar observatory); and Cluster (study of the magnetosphere);
- Future projects, including the XMM project (X-ray spectroscopy), a mission to retrieve samples from a comet nucleus and to conduct submillimetric astronomy experiments, and the Cassini Saturn observation project.

In the field of telecommunications satellites (3.05 percent), the following projects are included:

- The point-to-point European Communications Satellites (ECS) operated by Eutelsat;
- The interorbital telecommunications satellites IOC/Eureca and DRPP/PSDE/DRTM (data relay satellite system);
- The Advanced Systems and Technologies Projects (ASTP) preparing future ESA telecommunications programs.

Earth observation programs (2.95 percent) include the Lasso-P2 project (clock synchronization by laser); the ERS-1 [Earth-Remote Sensing] satellite (ocean observation), whose launch is planned for the end of 1990 at the earliest; the Earth Observation Preparatory Program (EOPP) to study technologies of the future; and the Polar Orbital Mission (programmed as part of Columbus).

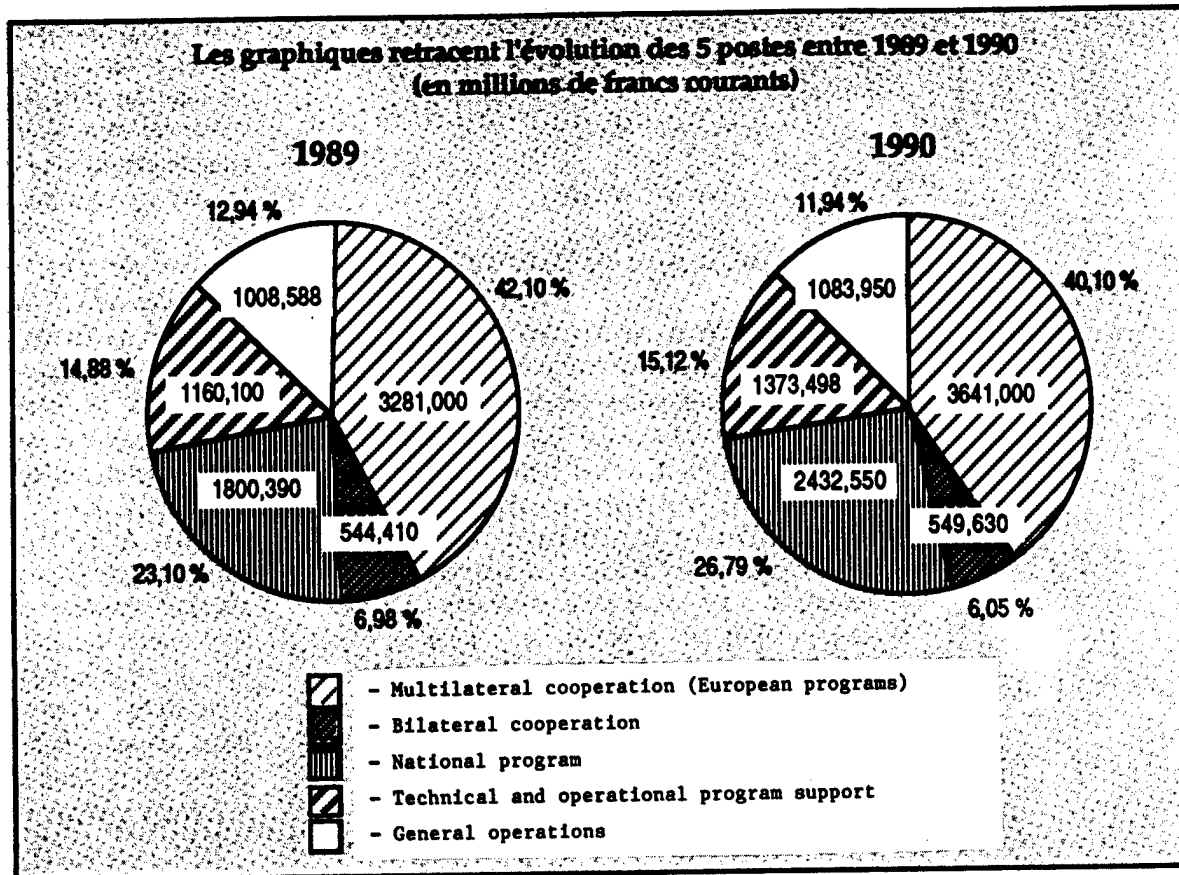

Spacecraft programs (6.71 percent) include Spacelab in liaison with studies on the European Retrievable Carrier (Eureca) platform, microgravity research, and the development of the Columbus space station.

In the area of launching equipment (75.55 percent), most of the funding goes to the Ariane program. The Ariane-5 launcher, which will be operational in 1995, will make it possible to put 6,800-kg payloads in geostationary orbit or to launch the Hermes spaceplane. The program includes Ariane upgrading activities. The Hermes spaceplane is essential to achieve European independence in manned space flights. Hermes will be used to service the Columbus space laboratory and the international Freedom space station (which includes the European APM module) as well as to conduct unmanned flights dedicated to scientific endeavors.

France, as an ESA member-state, contributes to the funding of the Guiana Space Center.

General expenses constitute 4.24 percent of the budget for European multilateral cooperation.

Bilateral Cooperation

Cooperation with the United States (53.28 percent) includes:

- Scientific experiments, primarily with the Topex-Poseidon project (space oceanography), but also with the Windii-UARS (high-altitude wind and temperature measurement), LASE (study of the lower atmosphere), Ulysses (overflight of solar poles), and Galileo (exploration of Jupiter) projects.
- Earth observation, to exploit earth resources (experiments conducted using data from the U.S. satellites Landsat, NOAA, Seasat, etc.) and to collect meteorological data or carry out tracking operations (Argos system and the Sarsat program's Sargos equipment). The Soviet Union is a partner in the program for its Cospas system, which is compatible with the French-American-Canadian Sarsat program, aimed at the quick location of aircraft and vessels, equipped with a low-cost space transmitter, which are in distress. The CNES, which is participating in the operational deployment of the system, is developing new instruments to ensure the system's continuation into the mid-1990s.

- Manned space flights involving experiments in the field of physical sciences with Mephisto or in the field of life sciences with Rhesus (animal experiments) and As-de-Coeur (cardiovascular adaptation experiment).

Cooperation with the Soviet Union (17.32 percent) includes numerous scientific experiments with the Sigma and Phebus telescopes (launched in 1989), Gamma-1 (launched last July); participation in the Phobos experiment conducted in 1989, involving a flyby of Mars and of its Phobos satellite; the Interball experiments to study the interactions of solar winds, magnetosphere, and ionosphere; the Scarab project (study of the Earth's radioactivity); the Alissa project (use of a lidar from space); and the French experiments for the major Soviet mission to the planet Mars planned for 1994. Following the 26 November to 21 December 1988 manned space flight, in which the French astronaut Jean-Loup Chretien participated, an agreement in principle was reached with the Soviets on a long-term program (the French Antares payload experiment program and experiments on board the Soviet MIR space station).

Cooperation with the European Space Agency (15.34 percent) focuses on scientific development experiments. These include the ISO Spectro interferometer, the Camisole two-way infrared camera, the FIRST instrument for submillimetric astronomy, and the ATSR-M radiometer on board the ERS-1 satellite. The SOHO satellite will study the Sun (launch in 1995) and the Cluster satellites will study the Earth's magnetosphere. The CNES is also cooperating with the ESA in the Silex telecommunications program for establishing experimental links between two satellites. Manned space missions are being prepared for Spacelab-D2 (German flight in 1992) and the Eureca platform (initial flight scheduled for 1991).

Cooperation with the FRG (7.46 percent) is continuing in the scientific field with the University of Tuebingen (development of a spectrophotometer). However, collaboration with Germany is mainly in telecommunications with the German TVSAT and the French TDF programs for direct television satellites; the two French TDF-1 and TDF-2 satellites were launched in October 1988 and in July 1990 and the German TVSAT-2 satellite in August 1989.

The CNES is also cooperating with other countries (6.6 percent), such as Sweden with Viking and Tele-X, and it is conducting bilateral projects with a view to export (training, promotion of SPOT and Ariane, engineering, etc.). The CNES is conducting awareness activities toward major international bodies to foster the space-role image of France.

National Program

In addition to balloon experiments and projects involving space transportation systems, the national program covers two major areas:—the SPOT satellite system,—the research and technology program.

In 1990, the scientific experiments (0.37 percent) involve balloon experiments (submillimetric Pronaos telescope) and geodetic experiments.

In the field of telecommunications, an agreement has been concluded between the CNES and France Telecom for the establishment of a Telecom-2 satellite program management team in order to ensure the continuity of the national telecommunication system beyond Telecom-1.

The Earth observation experiments (82.96 percent) planned for 1990 entail the use of data from the SPOT and ERS-1 remote sensing satellites.

SPOT-2 was launched in January 1990 and SPOT-1 continues to operate properly. SPOT-3 will be ready for launch in 1992 and the government's decision to develop SPOT-4 ensures that the system will operate until the end of the century. In addition, the revenues from the sale of images cover an increasingly greater portion of the operating costs. Lastly, the CNES is responsible for the overall architecture and for the space component of the Helios military satellite system.

The balloons (1.04 percent) are an original complement needed in the aeronomic and meteorological observation programs for altitudes between 15,000 and 45,000 meters. More than 50 flights are being carried out in France and abroad with ever more important loads for increasingly longer periods.

In the space transportation systems field (3.08 percent), the CNES is participating on the national level, in parallel with its European activities, in the development of the Ariane and Hermes programs.

The research and technology program (11.88 percent) in 1990 emphasizes the improvement of competitiveness in mobile communications, Earth observation, and scientific instrumentation; the pursuit of efforts in priority fields such as new uses of orbital infrastructure; and the procurement of basic technology for future launch equipment.

Funding is also allocated to programs to improve the quality and reliability of space vehicles for future programs (0.62 percent).

Technical and Operational Support of Programs

This budget category amounts to Fr2,457.448 million in 1990 compared to Fr2,168.688 million in 1989. It is used to fund the implementation of "heavy equipment," such as control station networks, computer networks, and metropolitan test centers (Fr238.300 million) and the Guiana Space Center (Fr647.500 million). Funding for scientific laboratories (Fr47.900 million), infrastructure and equipment projects (Fr339.220 million), and miscellaneous projects (Fr100.578 million) (participation in Ariane's capital) are also included in this budget.

General Operations

The general operations of CNES services (personnel and operating costs, public relations, travel costs) represents Fr 1,083.850 million. The CNES is expected to have a staff of 2,402 at the end of 1990 broken down as follows:

Paris Headquarters	208
Evry Space Center	224
Guiana Space Center	322
Toulouse Space Center	1,648

ESA To Participate in International Microgravity Experiment

91MI0021 Bonn *TECHNOLOGIE-NACHRICHTEN*
MANAGEMENT-INFORMATIONEN in German
26 Sep 90 pp 17-18

[Text] The European Space Agency [ESA], together with the recently founded Canadian Space Agency (CSA), the French National Center for Space Studies (CNES), the German Aerospace Research Institute (DLR), and the Japanese Space Agency (NASDA) will be working with NASA on the International Microgravity Research Laboratory's IML-1 mission, in which more than 200 scientists from 13 countries will be taking part.

The aim of the new mission is to carry out scientific and technological experiments under microgravity conditions in space. Science worldwide will profit from this research: The biological and materials science experiments will improve our knowledge about man and his environment and about physical processes that cannot be simulated on earth.

The IML-1 team consists of seven members: captain Ronald Groke, pilot Stephen Oswald, the three mission specialists Bill Ready, Sunny Larker, and Norman Thagard, and payload experts Ulf Merbold and Roberta Bondar, plus deputy payload experts Roger Crouch and Kenneth Money.

ESA is providing two facilities: the biorack and the equipment for critical point experiments (CPF). This item looks like a metal cabinet and is used to study fluids during their transition from the fluid to the gas phase.

The CPF is equipped with a camera system, laser instruments, a keyboard, and a video screen that are used to conduct the experiments, which take place inside a volume-, temperature- and pressure-controlled container.

Each chemical substance has three different phases: the fluid, the solid, and the gas phase. The critical point, at which it is impossible to distinguish between the fluid and gas phases, is reached under certain volume, pressure, and temperature conditions.

Wilson established the laws of renormalization theory, which describe what happens at the critical point. Verification of this theory requires experiments for which the microgravity in space provides ideal conditions.

On earth, the hydrostatic pressure caused by gravity sets limits on the experiment. "The critical point is only achieved in a very thin layer," explains Dr. Merbold. "There is nothing we can do about that, but the problem does not exist in space, because there is no gravity." Ingenious laser systems and optics in the CPF facilitate investigations of thickness variations and nonhomogeneity.

Dr. Merbold demonstrates the process of transition from fluid to gas phase and vice versa. He does this by altering the temperature of a small vessel containing the right quantity of sulfur fluoride (SF₆). At room temperature, about 20°C, the chemical is clearly liquid, but as soon as he warms it in his hand to 28.78°C, the pressure rises a little, as the gas expands and reaches a pressure of 38.6 bar. This is the critical point, and it can no longer be said whether the chemical is fluid or gaseous. As soon as it cools down, the retort clouds over and droplets are formed. Because of earth gravity at 1 G, separation takes place immediately. In space, the droplets would remain in suspension. Research work on fluid physics should extend our knowledge of the basic processes.

The biorack is a multipurpose device for investigating the effects of gravity, microgravity, and cosmic radiation on biological specimens such as living cells, tissues, bacteria, plants, and insects.

The biorack in the IML-1 mission has three incubators, a glove box, and a refrigerating and freezing unit, which enable the scientists to breed and experiment with hundreds of biological specimens and to preserve them for further studies on earth.

A selection of 17 experiments has been made for research in fields such as cell multiplication and differentiation, genetics, the development processes involved in fertilization and the first cell divisions, and the search for gravity-sensitive mechanisms and sensors in plants and cells.

Almost half the ESA biorack resources will be reserved for complementary American experiments, which will focus primarily on genetics and radiation biology.

Costs Mount in European HERMES Space Program

91MI0020 Bonn *TECHNOLOGIE-NACHRICHTEN*
MANAGEMENT-INFORMATIONEN in German
26 Sep 90 pp 16-17

[Text] It is already expected that the initial 8.5 billion Deutsche mark [DM] budget (FRG share DM2.3 billion) for the HERMES European space project will hardly be

sufficient. The ESA [European Space Agency] will therefore have to develop technical concepts that will keep the cost factor calculable.

For this reason, the complicated, heavy life-saving capsule originally planned has been canceled after long studies. Instead, the three HERMES astronauts would be catapulted out of the cockpit in special ejector seats in an emergency. This solution is just as safe, but much cheaper. But Europe wants to go its own way as far as designing the heat shield for HERMES is concerned.

The Americans' negative experience with the cemented heat tiles that keep falling off the Space Shuttle has led to the development of a new process for measuring temperature distribution in space. When the spacecraft re-enters the earth's atmosphere, the outer skin is directly exposed to temperatures up to 10,000°Celsius. The LIPF (laser-induced predissociation fluorescence) measurement process developed by Prof. Peter Andresen will be used to determine the thermal stresses to which the spacecraft will be subjected. Using LIPF, this scientist with the Max Planck Institute of Flow Research in Goettingen has succeeded in making the temperature distribution in the flows surrounding spacecraft visible, photographing, and measuring it in preliminary tests. In 1989 his development of LIPF earned Andresen the DM120,000 Philip Morris Research Prize "Challenge to the Future," which has been awarded for outstanding innovative achievements in science and research for the past seven years.

Andresen says of the project: "The idea is to clad the areas on the shuttle exposed to the highest temperatures with a special re-entry surface." Then heat treatment and pressure distribution are realistically simulated in the wind tunnel. Andresen continues: "With our measurement system, we can determine the highly accelerated gas flows, which reach a speed of 8,000 meters per second, their density, temperature distribution, and chemical composition. We can only take the necessary action when we know exactly what happens during the shuttle's re-entry phase," says the Philip Morris prize winner by way of illustration of the practical results that LIPF will bring. A special wind tunnel will be built in Goettingen by the end of 1991. Project costs: about DM21 million.

However, the initial findings have already convinced ESA: Unlike the American shuttle, the HERMES heat shield will not be made of special materials cut into tiles, but of about 850 carbon plates. MAN [Augsburg-Nuernberg Machine Works] is developing ceramic shingles that are not applied with adhesive but fixed with ceramic screws. ESA is hoping for another cost saving here.

UK, Soviets Cooperate in Satellite Launch Project *91AN0061 Brussels EAST WEST in English 24 Sep 90 pp 13-14*

[Excerpt] British Aerospace PLC has signed a six-month protocol with the Soviet Ministry of Aviation Industry to study a new low-cost way of launching satellites. The agreement is to investigate the feasibility of using an unmanned reusable earth-to-orbit satellite launch vehicle, which could itself be launched from a Soviet Antonov AN-225 super transport aircraft, the world's largest aircraft. The vehicle would be based on the British project to build a Hotol (horizontal take-off and landing) space ship which stopped when the British Government withdrew funding in 1987.

The Soviets have already used the Antonov to launch their equivalent of the space shuttle but with the Hotol technology it is thought that satellite launches could be only a quarter of the cost of the United States' space shuttle (\$15 million instead of \$60 million).

By using an air-breathing engine for the initial stages of the flight, the Hotol vehicle will not have to take off from a runway and so design and performance can be greatly improved and the vehicle can have high performance rocket propulsion. The use of the Antonov will also greatly reduce the development costs of the project.

The new project will use, if it is practical, an "interim Hotol" which will launch satellites at an altitude of 9,000 meters from the back of the Antonov. The estimated cost of the Hotol, which could take 10 years to bring into production, is \$4.32 billion. [passage omitted]

German Aerospace Research Institute Opens Spaceflight Centers

91MI0024 Bonn WISSENSCHAFT WIRTSCHAFT POLITIK in German 3 Oct 90 p 7

[Text] At the end of September the German Aerospace Research Institute (DLR) inaugurated three new spaceflight centers in Oberpfaffenhofen: the Operational Manned Spaceflight Center, the Subscriber Data Center, and the Automation Technologies Center. The federal government and the Free State of Bavaria will each pay half the overall cost of 84.4 million Deutsche marks for these three major projects.

The Operational Manned Spaceflight Center forms part of the DLR mission control center, which has had responsibility for conducting many unmanned (e.g., ROSAT) and manned Spacelab missions (e.g., D-1). While unmanned satellites and probes will still be covered from the existing control rooms, the new operational center is reserved for future manned missions. The first to be operated from it will be the D-2 Spacelab mission in 1992. The Subscriber Data Center is part of the DLR's German Remote Sensing Data Center, and will operate as a satellite image-based "eco-databank." It is designed to make the data coming in daily from

various satellites accessible in processed form to political, industrial, and scientific subscribers. Meaningful images will be produced from the "raw data" using processing and interpretation procedures and incorporating additional material, for example data obtained during flights by DLR's own research aircraft. The Automation Technologies Center is housed in the DLR Institute of Flight System Dynamics. Its main responsibilities are robotics and "interdisciplinary design and total evaluation of active dynamic systems." The long-term aim of using robots in space is to relieve astronauts of tasks outside the spacecraft.

Germany: Laser Procedure Measures Hermes Re-Entry Temperatures

90WS0106A Frankfurt/Main FRANKFURTER ZEITUNG/BLICK DURCH DIE WIRTSCHAFT in German 12 Sep 90 p 8

[Unattributed article: "Procedure Simulates Thermal Stresses During Return to Earth: Laser Measurement Technique Supports Heat Shield Design for Hermes Space Shuttle"]

[Text] Frankfurt, 11 Sep—The Hermes space shuttle is supposed to transport personnel and materials into earth orbit beginning in 1998. Of primary concern at present are project costs. It is already clear that it will be virtually impossible to stay within the planned budget of 8.5 billion German marks [DM]—German share: DM2.3 billion. Therefore, the European Space Agency (ESA) must develop technical concepts which can keep costs reasonable.

Thus, after long research, the complex and heavy rescue capsule originally planned was scrapped. Instead, in the event of an accident, the three Hermes astronauts would be catapulted from the cockpit with special ejection seats. According to ESA assurances, this is an equally safe, but much less costly alternative. However, Europe intends to go its own way in the design of the heat shield for Hermes.

A space temperature distribution measurement method recently developed by German scientist Peter Andresen should prevent bad experiences such as those the Americans have had with the glued-on thermal tiles constantly falling off the space shuttle. Because temperatures up to 10,000 degrees Celsius are generated at the external surface upon re-entry of the shuttle into the earth's atmosphere. The reason for this is the enormous re-entry speed of 7.8 kilometers per second. That amounts to 28,000 kilometers per hour.

Andresen's measurement method, dubbed "Lipf" (laser induced predissociation fluorescence), is being used in the research into these thermal stresses on the shuttle. Using "Lipf" in preliminary wind-tunnel tests, the Goettinger Max-Planck Institute for Aerodynamic Research scientist has succeeded in making the temperature distribution in the flow around aircraft visible and in photographing and measuring it. Andresen received the

Philip Morris "Future Challenge" Research Prize of DM120,000 for developing Lipf.

Andresen speaks about the project; "The idea is to sheath the shuttle with special re-entry surfaces at those points with the highest temperatures." Then, thermal stresses and pressure distribution are realistically simulated in the wind tunnel. "With our measurement system, we can measure the highly accelerated gas flows, which reach a speed of 8,000 meters per second, their density, temperature distribution, and chemical composition. Only when we know exactly what happens during shuttle re-entry can we plan appropriately," explains the scientist with reference to the practical consequences of the use of Lipf. A special wind tunnel will be built in Goettingen by the end of 1991 at a cost of approximately DM21 million.

But already based on the first test results, ESA is certain that, in contrast to the [U.S.] space shuttle, the Hermes heat shield will not be made of special customized tile material, but of approximately 850 carbon plates. MAN AG of Munich developed the ceramic shingles, which will be attached with ceramic screws rather than glued. Here again, ESA is anticipating savings.

COMPUTERS

Siemens Chief Discusses Computer Market Trends

90WS0108 Hamburg DER SPIEGEL in German 17 Sep 1990 pp 173, 176, 178-179

[Interview with Siemens CEO Hermann Franz in Munich by DER SPIEGEL editors Rudolf Wallraf and Klaus-Peter Kerbusk; date not given: "Frictions Unavoidable"]

[Text]

DER SPIEGEL: Mr. Franz, has Siemens come to regret the acquisition of the Nixdorf computer group?

Franz: Before we can even talk about having regrets we are going to take advantage of an opportunity. The new company, Siemens Nixdorf Informationssysteme AG, will not start operations until 1 Oct 1990. This is an opportunity we are not going to miss.

SPIEGEL: Are you sure that you will be able to bring Nixdorf back on course?

Franz: We did not approach this acquisition naively; we know what we are facing. There may still be a few unexpected problems; but essentially, we know what we are getting into. When all take-over formalities have been taken care of by 1 Oct, we will charge ahead.

DER SPIEGEL: How bad was it really in Paderborn?

Franz: By now, everybody knows that Nixdorf fell on bad times because of corporate mistakes and a difficult market situation. That is why I do not want to tell any

horror stories here. For us, the important thing is what we can make out of this commitment. In the past, Siemens has taken over lots of other companies which were in trouble. We have some experience in judging what is feasible.

DER SPEIGEL: Hardly any European computer company is making money.

Franz: You are wrong. After all, in 1989/90 Siemens made a profit of 250 million German marks [DM] after taxes in this product line. We will not carelessly put this at stake.

DER SPEIGEL: When will Siemens Nixdorf Informationssysteme reach the break-even point?

Franz: For our operations, we expect to make a profit during our next business year, i.e., 1990/91.

DER SPEIGEL: Do you want to talk up the Nixdorf stock price? From losses in the range of DM1 billion in 1989 heading straight into the black—that is very optimistic indeed.

Franz: But it is possible. First, we can realize a lot of savings. Just by combining our development activities and coordinating our product lines we can restructure a good part of our operations.

DER SPEIGEL: Is that a euphemism for mass lay-offs?

Franz: Naturally, there will be friction when two companies of this type merge. However, in the Nixdorf case, the necessary decisions had been taken before the merger. A reduction of the Nixdorf workforce by 3,500 which had been decided a long time ago was essential for the company's survival with or without the Siemens takeover. This streamlining process has been completed. We do not expect any dramatic changes in the future.

DER SPEIGEL: But you do not exclude further lay-offs?

Franz: I emphasize the word dramatic. I can't tell you anything definite yet, because we have not finished our homework. We do not know yet for sure which Nixdorf products will be produced in which Siemens factories and which Siemens products will be transferred to Nixdorf.

DER SPEIGEL: The latter is probably less likely.

Franz: We will not steamroller Nixdorf. When we allocate the products, we will consider all sites.

DER SPEIGEL: We heard of plans to shut down the production of Nixdorf PCs in Berlin and the facility for computer printers in Cologne.

Franz: There will be no shut-down, rather a transfer. It would make no sense to produce PCs at two facilities. Siemens has a fully automated factory in Augsburg with sufficient free capacity. This measure affects only about 100 of approximately 800 employees in Berlin.

DER SPEIGEL: In many factories, Nixdorf manufacturing expenses are too high. Which of these plants are in danger?

Franz: Certainly, Siemens has more efficient operations. We will contribute the experience we have in the production of larger quantities and automated mass production. The Nixdorf employees are aware of this, and that is why they received us with open arms.

DER SPEIGEL: The team will remain insecure until the question of workplaces is settled.

Franz: The insecurity among the employees disappeared when it became clear that their competitor who previously was considered an archenemy will take over Nixdorf. They know that they have a financially strong partner on board who will contribute not only funds, but also technology and a solid market position.

DER SPEIGEL: When will the Nixdorf brand disappear completely?

Franz: We started the company Siemens Nixdorf Informationssysteme. It would be foolish to abandon the Nixdorf name. Both are proud names, Siemens and Nixdorf, and both will appear on the products.

DER SPEIGEL: What made Nixdorf so attractive for Siemens?

Franz: The fact that we have practically no overlapping product lines or regional markets. In our opinion, Nixdorf contributes those market segments to our program, which we wanted to enter anyhow. Siemens had started to enter the computer field with open systems...

DER SPEIGEL: ...which can use programs of different manufacturers.

Franz: This would have meant a head-on collision with Nixdorf over the next few years. Who do you think would have lost?

DER SPEIGEL: You tell us.

Franz: If we both had gone for all-out competition, Siemens probably would have had the better chances in the long run. Therefore, this solution is best for all parties.

DER SPEIGEL: With the Nixdorf acquisition, you probably also wanted to prevent a foreign competitor, possibly IBM, from taking over your most important German competitor?

Franz: I don't think IBM could have taken over Nixdorf because of antitrust laws. Naturally, every move also involves defensive or cover actions. But the real reason was the synergy I talked about and, in particular, the 100,000 additional customers.

DER SPIEGEL: However, these customers are in a state of uncertainty because they wonder whether they invested in the wrong systems.

Franz: This is the most important question which we asked ourselves right from the start. It is quite clear: if we want to keep the customer base we cannot change our product line radically. We must have a transition period during which we continue to offer products which were exclusively Nixdorf products, and products, which were exclusively Siemens products. These computer lines will not be combined until the next generation.

DER SPEIGEL: When will that be?

Franz: We expect this to happen by 1992 with the open systems of the middle-range computer categories. As to PCs, we will be offering joint models very shortly, because their product cycle has ended and also because the PCs are less software dependent.

DER SPEIGEL: PCs are the computer area with the biggest growth potential, and that is precisely where Siemens and Nixdorf are rather weak. Were both companies sleeping?

Franz: We were not sleeping. As a matter of strategy, both companies had decided not to enter the consumer market. We will continue to leave this market segment to the mass producers in the U.S. and the Far East.

DER SPEIGEL: Why?

Franz: We are not Apple, just to name one PC producer, and we do not want to become a company like Apple. We manufacture professional computers and offer systems and problem solutions.

DER SPEIGEL: How do you rate Siemens-Nixdorf's chances against international giant IBM?

Franz: We have no delusions of grandeur. With sales of DM110 billion, IBM's computer sales are eight times those of Siemens and Nixdorf combined. We want to become a leading company in Europe, and possibly displace IBM from its number one position in Germany.

DER SPEIGEL: Just recently, the British computer company ICL was sold to Fujitsu. Now you have the Japanese right at your doorsteps.

Franz: This was to be expected. However, it would be wrong to buy up just anything that is on the market. ICL was offered to us, and we entered negotiations. However, the systems did not match, there were no synergies, and in addition, we did not like ICL's strong ties to British authorities.

DER SPEIGEL: Rumor has it that the computer divisions of Philips and Olivetti are also up for sale. This might be something of interest for Siemens?

Franz: With the purchase of Nixdorf, we have established a strong enough position in Europe for the time being. The integration of two large companies with more than 50,000 employees is not easy. Once this has been accomplished, we can consider further steps: but who knows what the situation will be like at that time.

DER SPEIGEL: European computer competitors are throwing in the towel because they cannot keep up with technology. How well is Siemens equipped?

Franz: We think we are just as good as the Americans or the Japanese when it comes to computers. The growth rates at Siemens in the past few years proved that. We always grew quite a bit more than the market in general. This is the best indication that we can keep up technologically.

DER SPEIGEL: As far as the basic technology of chip development is concerned, Siemens is lagging behind the leading Japanese companies.

Franz: I do not know what makes you think that. Siemens was the first European company to mass produce the 1 MB [megabyte] chip, even though somewhat later than the Japanese. With the 4 MB chip we pulled even. Incidentally, we are the only European company to produce this chip for industrial applications. We introduced the prototype for the 16 MB chip. Here, too, our technology is at the same level as that of our competitors.

DER SPEIGEL: Perhaps only on paper, because 90 percent of the memory chips used in Europe come from Japan or the United States.

Franz: Undoubtedly, mass production is concentrated in Japan and the Far East in general. This is the result of a development which started many years ago. We now have to live with its consequences. The Japanese have almost the whole entertainment electronics area...

DER SPEIGEL: ...TV, video recorders or hi-fi equipment...

Franz: ... to themselves. These devices use large amounts of so-called standard chips. This is a fact which cannot be undone.

DER SPEIGEL: Why doesn't Siemens yield chip manufacturing to the others altogether?

Franz: Our management board asked this question six years ago and took a basic decision. The answer was: We must participate if we do not want to lose our own industrial base.

DER SPEIGEL: What do you mean by that?

Franz: We develop customized chips for our products. These so-called logic chips are used in computers, but also in telecommunications, automotive electronics, medical technology and in automation technology. These are all growth areas which we defined as key targets for our corporate strategy. If we reveal the necessary systems knowledge to others who would have to incorporate it into the chips, we could easily find ourselves in a tight corner.

DER SPEIGEL: How?

Franz: In the first place, Siemens or other European electronics manufacturers would reveal their know-how.

And secondly, they would be open to any form of blackmail from the suppliers in the Far East.

DER SPEIGEL: We know of chip users who are complaining that the Japanese take care of themselves first if there is a bottleneck. Would the lights go out in Europe, if the Japanese stopped their shipments?

Franz: I would not say that the lights in Europe would go out without Japanese chips. Certainly, there would be some disruption. This is exactly why we Europeans must not abandon the area of customized chips without a fight. However, to be able to produce these chips, you have to know how to build the standard chips on which they are based.

DER SPEIGEL: How much does Siemens spend on chip development per year?

Franz: We spend approximately DM7 billion for R&D. Approximately 30 percent of this amount goes to chip technology in its broadest sense.

DER SPEIGEL: How much government subsidies do you get?

Franz: Government grants account for only three percent of those DM7 billion.

DER SPEIGEL: Your company has a cash reserve of DM20 billion. With such a cushion, aren't you embarrassed to ask for tax money?

Franz: Not at all. Nobody gives up government subsidies voluntarily, subsidies which benefit not only the company, but the economy as a whole. It is not only a question of Siemens but a question of the independence of German, even European industry. It is not necessary to beg for something like that.

DER SPEIGEL: This sounds as if you were very much concerned about the country as a whole.

Franz: This is absolutely true. I will give you an example: We are building customized chips for use in automotive electronics. The automotive industry is one of the key sectors of our economy; it is in keen competition with the Japanese. Do you think our colleagues at Mercedes, BMW, and others would be happy if their developmental work depended on the Japanese?

DER SPEIGEL: That is why Siemens needs government subsidies?

Franz: The federal government in Bonn is not the only government to give subsidies. The other European governments are much more generous. The Japanese receive even larger amounts, and the Americans get financing for their developments via defense contracts. Therefore, it is also a question of balancing out uneven competitive conditions.

DER SPEIGEL: In the Jessi project, European electrical/electronics companies are jointly developing new

high-speed chips. Does this project fall through now that Philips, the Dutch company, has withdrawn?

Franz: Philips spent a lot of money on semiconductor technology and completed the megaproject together with us. In my opinion, the Jessi project is not in jeopardy; it will be continued by the other partners.

DER SPEIGEL: You are negotiating with the Italian-French group SGS-Thomson about a cooperative venture? When will this come about?

Franz: We have come to a basic agreement that we want to work together. Currently, we are discussing in which areas we want to cooperate. I cannot say whether we will be able to start by the end of this year.

DER SPEIGEL: You are developing the 64 MB chip together with IBM, you are producing it together with SGS-Thomson. Where will it end, if everybody joins forces with everybody else?

Franz: It does not always have to be a merger at the corporate level. Technological cooperation would be enough. As far as I am concerned, this network could be worldwide.

DER SPEIGEL: Could you imagine a Japanese participation one day as well?

Franz: Why not? In fact, they are participating already. On some level, be it as a supplier or buyer, a patent or other licensee, all large European companies work together with the Americans or Japanese. However, to be able to participate in a worldwide network of technological development one has to have something to offer. Only then can one be a member of the family. If a company has nothing to offer, it is left standing outside the door, in the true sense of the word.

DER SPEIGEL: A worldwide electronics family where nobody hurts the other one. Is that your ideal view of competition?

Franz: Competition will certainly not be eliminated. On the contrary, competition is getting increasingly tougher. At best, you can hang a chip around your neck; it serves no purpose at all by itself. Chips are the raw material from which products and systems are made. That is what counts.

DER SPEIGEL: Mr. Franz, we thank you for this interview.

Germany: New Optical Disk Computer System Described

*90WS0106C Frankfurt/Main FRANKFURTER
ZEITUNG/BLICK DURCH DIE WIRTSCHAFT
in German 20 Sep 90 p 10*

[Article by Volker Heiner: "Faster, More User-Friendly Access to Large Quantities of Computer Data: Optical

Disk Makes Microfilm Superfluous/How Triumph International Archives Its Customer Orders]

[Text] Frankfurt, 9 Sep—To enable accessing of large quantities of electronically archived data in split seconds, the Munich management consulting firm TIA has developed a new information and archiving system called "Mirsys-Cor." In this system the data are stored directly on optical disks; microfilming is no longer used. The Computer-Output-Retrieval-System (COR) has been in use since the beginning of this year in the customer order department of the firm Triumph International where it complements the computer-aided microfilm processing of paper records.

Each year approximately 2.2 million documents are handled by the customer order department; about half are computer data and half paper records—and all of them must be processed and archived for legal or company-internal reasons. The rapid availability of information for all customer inquiries is of primary importance in retrieval both of "EDP-documents" and paper documents.

Therefore Triumph is using a multistage mainframe information system from the time of receipt of the order to delivery and invoicing, whose "lowest" level is computer-aided access to optical disk and microfilmed paper documents.

Because optical memories with high storage capacity are now available, Triumph decided to put the COR process to practical use. Since the beginning of this year, computer-generated records such as packing slips, invoices, accounting records, and customer information have been stored on WORM [Write Over Read Many] disks rather than on film. A "media gap" between analog and digital storage environments is thus avoided because these data are archived in the medium in which they were produced—i.e., the computer system.

This quantity of data produced daily on the central computer (e.g., 5,000 customer invoices/packing slips per day) is diverted to the Mirsys-Cor system for archiving. There, the printer control codes are neutralized in a filter program so that the system will be operationally compatible even with future generations of PC's and printers. Through additional data compression, up to one million invoices and packing slips can be archived on a single 800-megabit WORM OD. Storage is byte-coded, i.e., the data are stored as characters.

Triumph order department manager Harald Kopp describes the capabilities of the newly developed Mirsys-Cor system as follows: "We used to have to film each individual document. Today, after reading the magnetic tape into our digital OD system, we can directly access the desired data. This improves our organizational cycles, saves time and, consequently, considerable cost."

Two types of data are handled separately by Mirsys-Cor: Informational data are, for example, transferred via printer-ready tape or even directly via "file" transfer

into the information and "retrieval" system, filtered, compressed, and written to the optical disk in byte-coded form. In the archiving of informational data, the indices for subsequent searching are automatically stripped off and stored in the system. In contrast, form data are only stored one time per form in the system and retained as "soft forms."

Searching is carried out on screen in the Mirsys program; display of the archived data likewise is on the standard screen of the system, i.e., no high-resolution video terminal is required. Any paper copies needed are produced by laser printer by overlaying the form (soft form) with the informational data.

Comparison of the running costs of this WORM application with equivalent microfilming reveals that the method introduced here is significantly more cost-effective. Additional areas of application are currently being transferred to the COR process, such as MDE (mobile data acquisition).

The Mirsys-Cor process has proved its worth for years for retrieval of "conventional records." This includes management of records which must be processed by the company, such as customer orders, incoming and outgoing correspondence, as well as internal records not generated on the in-house computer system.

The records are first stored on rolls of film. Searching, i.e., the search for one stored record, is performed by each worker at his own workstation. When he enters the known indices such as customer number, record type, and date on his video terminal, the program displays the location(s) of the record being searched. The worker then decides whether he wants to view the record stored on film at a decentralized read-copy station or, if need be, print it, or whether to send the data record thus located by the integrated mail boxing process to the central read-copy equipment for printing. Both the decentralized and the central read-copy equipment are connected on-line to the host computer. In addition to high availability and rapid access to archived records, the savings in personnel have been noteworthy.

At Triumph International the combination of the two information and retrieval processes for computer data on WORM disks and for written records on microfilm has resulted in cost savings. Most importantly, the integration of the COR process provides significant advantages in terms of speed and availability of information in the processing of customer orders.

The optical disk based information and retrieval system developed by the TIA management consultants is generally appropriate for all firms that produce large quantities of data to archive and must access this data quickly and reliably. These include, for example, industrial and commercial firms, banks, insurance companies, government agencies, transport services, or freight companies.

Suprenum's Financial Future Doubtful

90WS0090B Duesseldorf VDI NACHRICHTEN
in German 3 Aug 90 p 9

[Article by M. Groteluschen, "Ambitious Parallel Processor Project Threatened by Lack of Money."]

[Text] In the middle of last month, Suprenum set a speed record during a trial run. However, it also became clear that the project is suffering from money troubles.

Suprenum, the first German-developed supercomputer, is the talk of the town. Will there be no final stage to the maximum performance computer that is to execute an immense 5 billion computations per second (5 GFlops)? Is it even possible that the ambitious parallel processor project will fail shortly before entering the market? Newspapers reported recently of technical, financial, and organizational difficulties.

Half a decade ago, Suprenum began to build a German supercomputer in four to five years. The German manufacturer and project coordinator is Suprenum GmbH of Bonn. As early as the Hannover Fair in April of last year, the company displayed a prototype with a total of 32 processors. These were combined into clusters of 16 processors each. This system has a specified peak performance of 640 MFlops (million floating points operations per second). The largest system with 256 processors and a peak performance of 5 GFlops was to be ready by the end of the year.

There was another success story in autumn. The "supercomputer for numerical applications," so the long description, found its first buyer. The large-scale research facility GMD (Society for Mathematics and Data Processing, St. Augustin near Bonn) paid 21.5 million German marks [DM]. However, the GMD owns 20 percent of the association of manufacturing companies, and it appears that research money was only being redistributed internally to the project.

Two smaller units went to universities in Erlangen and Liverpool. However, these additional sales were overshadowed by decisions of the Federal Ministry of Research (BMFT). At the end of the year, Riesenhuber declared the joint project as ended. He refused to provide additional financial aid to the 14 institutes, technical colleges, and private companies involved. Indeed, the immense government support was the main point of attack by project opponents again and again. Headlines such as "200 million squandered for Suprenum" appeared in the press.

Professor Ulrich Trottenberg is managing director of Suprenum and one of the spiritual fathers of parallel computer. He will have none of this. "Suprenum was initially a broad research object. It was to introduce future-oriented parallel processing into the work of research facilities. That has succeeded completely." Of the total of DM160 million invested by the BMFT, more than one-half has flowed into universities and research

facilities. His association, Suprenum GmbH, receives only about six percent of the BMFT money for its task (participation in planning and management).

Trottenberg believes Suprenum has proven that parallel supercomputers can be built, operated efficiently, and easily programmed. Numerical parallelism has also pervaded the research world in the meantime.

In simpler terms, the idea is to decompose a mathematical problem into partial tasks. Then, the commands are executed not only sequentially but also in parallel with one another to save time. Vector computers already use this in a rudimentary fashion. The special feature of Suprenum consists of each processor having its own memory and central processing units. These units communicate with one another via a new type of connecting structure.

However, computer scientists report that precisely the problem of internal data distribution is not trivial. This is the problem of transmitting information between all or some selected processor units. They ask, how much communication is possible without impairing the computational performance of the system? Or, what use are the 256 processors for a real application program if the performance does not increase in proportion to the number of processors?

The Suprenum GmbH in Bonn points to the machine installed at the GMD in this regard. During the last test run on 19 July, this machine achieved 890 million flops with its 64 processors. "Thus, this is the fastest computer ever developed in Germany," claims spokesman Kurt Brand. In the final phase, a corresponding model would exceed 3 billion GFlops.

The men from Bonn are continuing hardware tests. They are also betting that the current need for applications programs will be met by the software houses. However, this will still take years. In addition, they carry on their marketing and financial procurement projects. "We are still taking part in requests for proposals from research institutes and industry firms," according to Brand. "And we hope the grant proposals submitted to the Ministry of Research will no longer be kept in cold storage." In addition, the Suprenum II project might be continued within the framework of the Genesis program.

Cymbal crashes are nothing new in the arena of "Formula 1 computers," which a few manufacturers control. Without warning, the American Control Data Corporation ended all supercomputer activities on 17 April 1989 and stopped work on the Eta 10 series begun in 1983. At that time, CDC had been in the market for more than twenty years. If the same fate befell Suprenum, the predominance of the Americans (Cray) and the gaining Japanese (Fujitsu, NEC, Hitachi) would take years to overcome.

Germany: Potential Applications of ILPRIOS Program Reviewed

90WS0083A East Berlin FEINGERAETETECHNIK
in German Jun 90 pp 271-273

[Article by Dr.-Eng. M. Herrig, Technical University Ilmenau, Instrument Engineering Section: "Potential Applications of ILPRIOS Program System"]

[Text] ILPRIOS (Ilmenau prism and optical system analysis program) is a 3-D optics analysis program which aids investigation of the effects of defects in optical systems.

Written in FORTRAN 77 as an interactive program, ILPRIOS runs on IBM-compatible PC's under the MS-DOS operating system.

For the intended use, it was necessary to supplement the face-based description which predominates in automatic correction programs with a component description of plane optic parts, with reflecting prisms receiving special consideration.

1. Prism Description

Prisms are represented as bodies with plane boundaries, i.e., as polyhedrons, and must thus be incorporated, analyzed, and modified as a whole in the system. The data chosen for describing prisms are the normal vectors of the prism faces and their distance from a coordinate system for prism description for a unit prism with free, unsupported heights; additionally, the three prism face numbers for all regular corners are reported.

The faces can be refractive, reflective, or opaque. They do not have to be described in the order of the passage of the ray and also need only be described once in the event of multiple contacts.

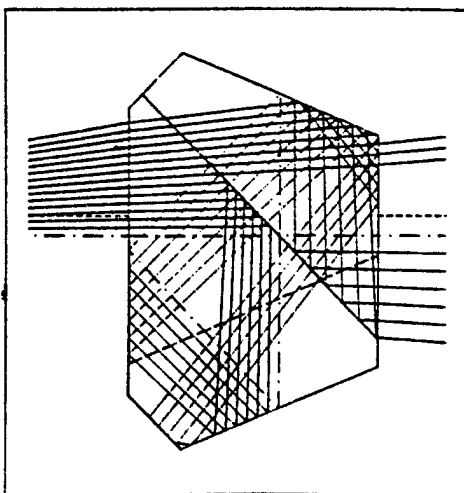

Figure 1 Course of ray in a Schmidt-Pechan Prism with lack of total reflection conditions.

For such a physical description, it was necessary to develop a ray tracing algorithm which provides unambiguous, physically meaningful results even when a ray falls on ridges (pentagonal prisms) or corners (triangular prisms).

With this algorithm, it is possible, for example, to investigate secondary reflections which occur in the image plane through lack of total reflection conditions or through exceeding the aperture provided (Figure 1).

The incorporation of prisms into the system description is supported in such a way that modification of the paraxial distance of intersection is taken into account and a dimensional recommendation for the free altitude can be called up but that exact prism size which causes no additional shading of the beam of rays is determined. Since most reflecting prisms deflect the optical axis, all components located downstream from the prism after it is installed are referenced by the new optical axis. To clearly define the orientation of the resultant coordinate system, in which, for example the image orientation is described, the altitude reference direction, whose position must also be represented graphically, is used. Reflecting prisms and mirror systems have labelled axes of projection which have minimum (innocence, invariance) or maximum (sensitivity) effect on image position or orientation.^{1,2} Such axes can be determined for prisms and groups of prisms, graphically represented, and considered in the description of component position errors.

2. Manipulation of Component Position

One type of modification of position in optical instruments occurs as a functional movement which results in a modification of the course of the ray desired by the developer; another type occurs as a position error which is caused by actual assembly processes during production and whose effect must be limited through defining tolerances or adjustments. Such modifications of position must be described in ILPRIOS through manipulations which are understood to be shifts and rotations around a predefined center of rotation and an arbitrary axis of rotation and whose effects are referenced by groups of surfaces and prisms. The user defines the scope of the groups which may also contain object and image spaces. Thus it is possible to describe movements within the sequence of reference systems generated during system input (Figures 2, 3, and 4).

Furthermore, all components located downstream from a prism can be altered in position by moving the reference coordinate system including the optical axis downstream from a prism. This description is accomplished in the same way as that for the manipulation of groups.

3. Graphic Representation

The examples shown and the possible applications presented clearly reveal that efficient, low-error work can be performed with such a program only with graphics support.

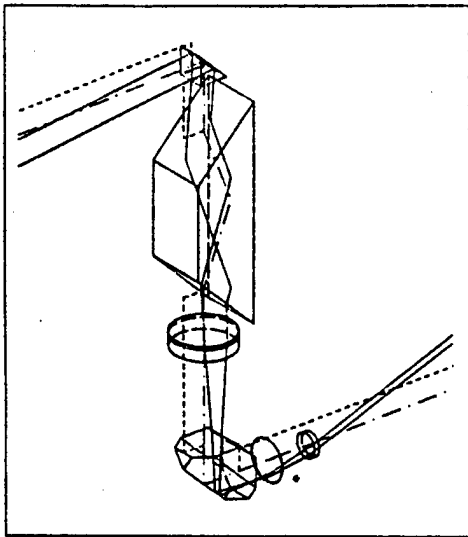

Figure 2. Panoramic telescope in the original position

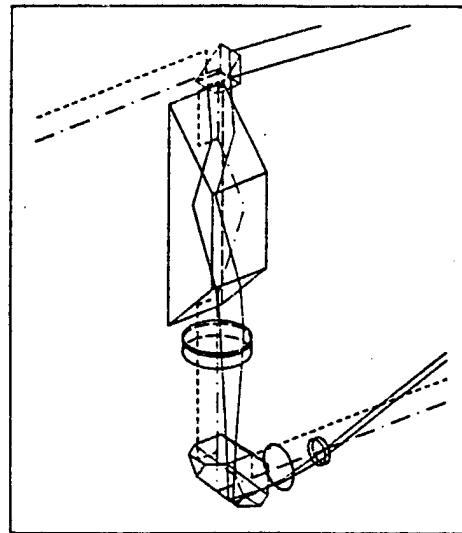

Figure 4. Position of the prisms with a 180 degree deflection

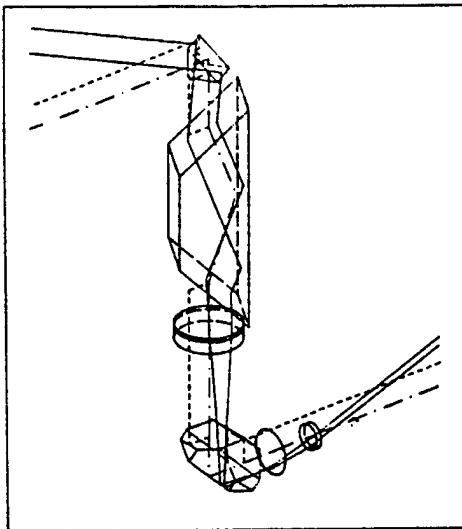

Figure 3. Semicubic prism rotated through twice a [given] angle, such as an image of a Dove prism

For graphic representation of the type, position, size, and sequence of the components and manipulations thereof, the program offers the capability of passing arbitrary sectional planes through the system and observing the parallel projection of the portion located behind the sectional planes. During this process, concealed lines are blanked out only within assemblies in the interest of shorter response times. The optical axis and the altitude reference sequence are included in such a representation as orientation aids; it is also possible to pebcil in rays and labelled axes of projections.

4. Image Aberration Analysis

Information about image quality is of fundamental importance in the analysis of optical systems. Preconditions for its assessment are the definition of the beam of rays which forms the object point under consideration in the image space and the selection of suitable reference values for calculating aberrations.

The beam of rays can be defined with the help of the effective aperture which is calculated with a paraxial approximation for decentered and manipulated components or iteratively for individual rays. The definition of the collection plane is used for a paraxial analysis of the straight-line, non-manipulated, and non-decentered system; in addition, calculation of reference points and lines is possible with a generalized astigmatic ray tracing algorithm.³ Both lateral aberrations and wave aberrations, but not chromatic aberrations, can normally be determined using two beams of rays per object point; the orientation of these beams depends on the calculated reference lines.

The image aberrations are represented in the conventional manner with correction representations. However, to permit analysis of the modifications in image aberrations using component manipulation in a user friendly manner with the help of variation tables, calculation of orthogonal developments of aberrations, of Nijboer-Zernike coefficients in particular, is also possible.

5. Descriptions of Variations

The mode of description of variations selected permits declaring blocks of arbitrary system description values as variation parameters, varying them within a single automatic program cycle, and also investigating their effect

on evaluation parameters also selected. This design makes it possible to calculate variation tables, but it also can be used to generate evaluation parameter diagrams which represent the modification of one evaluation parameter as a function of another while varying arbitrary system values. If, for example, the Y- and the X-components of the image-side direction of a dense ray are selected as the evaluation parameters and the rotational position of the Dove prism and the object point direction in the panoramic telescope from Figure 2 are alternately varied and if there is a defective axis of rotation not following the direction of the optical axis, a tilt direction plot is generated which represents the variation in the image position and orientation with such a rotation.

Furthermore, fault diagrams can be generated and linearity tests performed.

For establishing tolerances for prism angle defects, it must be possible to detect them unambiguously and independently of position errors. To support creation of such variation blocks, which contain the component manufacturing defects of prisms independently of their component installation errors, ILPRIOS offers the capability of describing such geometrically defined values of prisms as well as the method for retaining the degree of freedom of position and of representing them as combinations of the required tilting and shifting of the prism faces.

6. Adjustment Means

For accurately positioned installation of the assemblies it is necessary to determine and to compensate for the causes of malfunctions through additional optical adjustment arrangements.

Therefore, in addition to the function-based imaging of the object in the image space, such arrangements within the system can also be described and the reference image drift outside the reference marks resulting from assembly position and production errors can be analyzed in paraxial approximation. To encompass the most frequent adjustment arrangements, such as aiming, alignment, and centering, an adjustment mark and an adjustment telescope must be attached to individual groups or surfaces and positioned in such a way that the desired type of defect can be observed and detected with the defocusable adjustment telescope.

The reference image drift outside the reference marks caused by manipulation or variation of the adjusting arrangements can also be represented graphically like the variations in position and orientation of the image points in the image field of the optical system and commented on with additional arbitrarily selectable data parameters.

7. Conclusions

The program system presented should provide a tool for designers and developers of optical instruments which will permit not only views into the physical structure of optical systems but also insights into their behavior upon actual technical implementation.

Bibliography

1. Bochnia, A., "A Contribution to the Adjustment of Optical Instruments," Dissertation A, Technical University of Ilmenau, 1985.
2. Heidrich, T., "A Contribution to the Solution of Tolerance and Adjustment Problems in the Design of Optical Instruments," Dissertation A, Technical University of Ilmenau, 1987.
3. Schuetze, D., "Generalized Raytracing and Application," [FEINGERAETETECHNIK], Vol 32 No 11, 1985, pp 1385-1396.

ENERGY

French Firm Develops Diesel Alternative

91AN0054 Newbury FRANCE ALERT in English
3 Oct 90 p 32

[Summary of article published in Chislehurst AGRICULTURAL SUPPLY INDUSTRY in English 21 Sep 90 p 4: "France: Development of New Diesel Fuel Based on Rape Oil"]

[Text] A chemical derivative of oilseed rape oil has been developed by the French Oilseed Producers Federation (FOP) as an alternative to diesel fuel. Since France has very little indigenous oil resources, the development of the new product, Diester, is being watched with interest. Diester can be produced from any oilseed plant, such as soya, sunflower, or palm, in what is said to be a cheap and simple process. Tests on different types of vehicles with standard engines have been carried out using trial quantities of Diester produced at the Robbe crushing plant at Compiègne, France. No problems have yet been found with either the fuel or the engine. The future of Diester is, however, largely dependent on whether the product is exempted from France's internal tax on petroleum products.

FACTORY AUTOMATION, ROBOTICS

Germany: Control System for Flexibly Automated Assembly Cell Described

90WS0089A East Berlin FERTIGUNGSTECHNIK
UND BETRIEB in German Aug 90 pp 483-486

[Article by Dipl.-Eng. G. Neubert; Dr.-Eng. U. Walter; Eng. K. Kunze, GERFEMA, Chemnitz (formerly FZW): "Control of Automated Assembly Cell for Lathe Chucks"]

[Text]

0. Introduction

The goals, operation, and technical equipment of the automated assembly cell for lathe chucks were described in bibliography item [1] in terms of the mechanical assemblies used. This article supplements that by presenting the control engineering design of the assembly cell.

1. Control Engineering Concept

The control of the assembly cell is effected by an IR [industrial robot] controller of the type IRS 650 and a master process controller PC 602. The two controllers are linked to each other and with the functional groups via relay assemblies for voltage division.

The IRS 650 controller is used to operate the industrial robot IR 60E. It controls:

- the motion cycle of the robot,
- all hand and hand exchanging functions, and
- it implements the sensor functions of the robot.

The 12 robot programs to be used for the 12 types of chucks each include from 14 to 15.5 Kbytes and are recorded in an external memory. Before beginning an automated process, the program corresponding to the type of chuck must be read in to the user memory of the IRS 650, which has a maximum capacity of 16 Kbytes.

The PC 602 process controller is used to operate peripheral assemblies and to monitor the assembly cycle. It assumes the status of a control computer. It implements the following individual functions:

- enabling the functions of the peripheral assemblies,
- enabling stepwise execution of the program of the IRS 650,
- outputting signals to the bin controller to invoke feeding and removal of items for the assembly cell,
- monitoring assembly cell functions,
- stops the robot—STOP state—or the assembly cell—NOT-AUS [emergency stop] state—in the event of errors,
- displaying the relevant operating status and errors.

The PC program to be run, which was designed for all types of chucks, occupies approximately 15 Kbytes of user memory. It is stored in EPROM and contains the function complexes of setup operation, automatic operation, and monitoring.

A moment of force sensor, approach initiators, switches, a microscanner, and a light barrier are used to control and monitor the assembly cell.

The starting point for design of the assembly cell and the control program includes the following considerations:

- protection of workers,
- protection against damage to the assembly cell,

- control of all assembly procedures to avoid manual disassembly and damage to the product or to the peripheral equipment,
- extensive avoidance of interruptions in the automated process,
- precise "STOP" of the robot in the event of errors in the operating positions of the robot and the peripherals which do not prevent manual elimination of the cause of the error,
- minimization of situations which could lead to the "NOT-AUS" of the assembly cell,
- rapid determination of the cause of an error.

2. Program Structure of the IRS 650 Robot Controller

The program of the IRS 650 consists of an NC program and a PC background program.

Whereas the NC program is responsible for the functions:

- control of the robot motion cycle and thus of technical progress in the assembly process,
- control of the hand, the hand exchange unit, and the moment of force sensor,
- signal exchange between the IRS 650 and the PC 602, and
- monitoring the signal transmitter of the sensor and the appropriate response of the program depending on the signal status,

the PC background program is used only to link software input with software output.

All other functions are implemented via the process controller.

Each chuck type has its own program package consisting of a main program and approximately 20 subprograms in a five-level nest. The reenterability of many subprograms for several chuck types made it possible to avoid exceeding the maximum total number of 99 subprograms and at the same time minimized expenditures for programming.

3. Program Structure of the PC 602 Process Controller

The PC 602 program has the following features:

- division into the subprograms of setup operation, automatic operation, and monitoring,
- division of the "automatic operation" subprogram into main cycles and subcycles (Figure 2),
- rapid processing of specified input signals through the use of the interrupt capability,
- short actual cycle time by skipping nonessential equations in the respective calculation cycle.

Setup operation includes all subfunctions of the peripheral assemblies. These are, for example, the functions "turntable on," "vibrator operating," "screwer operating." Each subfunction of the assembly cell can be executed independently of other subfunctions.

Setup operation can be used:

- to evaluate subassemblies (e.g., for adjustment of the oscillation amplitude of the vibrators and longitudinal conveyers for supplying components),
- to adjust signal elements (switches, light barriers),
- to set up the starting state for automatic operation, and
- to eliminate errors that have led to the STOP state of the robot.

The PC 602 program is designed so that it is possible to control the assembly process for all 12 types of chucks

without changing programs. A four-place code (Table 1) which defines the program branches required for the individual chuck types is used for this. Before automatic operation begins, it is necessary for the operator to set the assembly cell to a specific initial state so it can be started and to avoid interruptions of the assembly process. This initial state includes the basic settings of the peripheral assemblies, the presence of the tools, the stock of components in the bin, the presence of palettes corresponding to the chuck type, and the pressure and levels of the media involved in the assembly process in question.

Table 1. Palette Coding

Initiators on WUE 1	B2	B3	B4	B5
Initiators on WUE 2	B7	B8	B9	B10
Relay cont. IRS 650	K2	K3	K4	K5
Chuck type				
DH—A160/3	0	0	1	1
DH—A200/3	0	0	1	0
DH—A250/3	0	0	0	1
DH—B160/3	1	0	1	1
DH—B200/3	1	0	1	0
DH—B250/3	1	0	0	1
DH—A160/4	0	1	1	1
DH—A200/4	0	1	1	0
DH—A250/4	0	1	0	1
DH—B160/4	1	1	1	1
DH—B200/4	1	1	1	0
DH—B250/4	1	1	0	1
K2 - L:	Type A (cover variants)			
K2 - H:	Type B (flange variants)			
K3 - H:	Four-jaw chuck			
K4 - H:	Size 200			
K5 - H:	Size 250			
K4 - H; K5 - H:	Size 160			
0...	Coding shut			
1...	Hole in Coding shut			
WUE	Horizontal transfer unit			

For automatic operation, parallel operation of the robot and peripheral assemblies was programmed wherever possible in the assembly process. It was thus possible to largely avoid having the robot wait for completion of technical activities of the peripherals.

This type of operation requires extensive signal exchange between the robot controller and the peripheral controller to coordinate program states. This signal exchange is linked to hand statuses and to the movements of the peripherals. Each hand movement is announced to the PC by the IRS. The PC verifies the

hand position according to the message and acknowledges the corresponding hand position. The robot continues its cycle of movement only after acknowledgment. Likewise, the position reached by the peripheral assembly is acknowledged and the cycle of movement of the robot is enabled.

Division of the automatic operation subprogram into a main cycle representing the robot movement cycle and into subcycles for control of the functions of the peripherals leads to an advantageous program structure. The advantages include the easy understandability of the



Figure 2. Excerpt from a cycle flow chart of the process controller E20 input 20 (NOT-AUS function); K7 input (acknowledgment signal of the IRS 650)

Key: 1. Excerpt from the main cycle flow chart—2. Lubricate gear ring—3. Join gear—4. Gear check screw—5. Join cover—6. Z... = states—7. Z1, Z2 = Timing circuits—8. Subcycle flow chart "Lubricate gear ring"—9. Position grease gun—10. Lubricate gear ring—11. Lubrication acknowledgment—12. Put grease gun aside—13. B... = approach switches—14. Counting circuits

program, the low effort required for necessary modifications, and the minimized memory requirement. Figure 2 presents an excerpt in the form of cycle flow charts.

The main cycle includes 27 states (Z), four of which, i.e., Z36 through Z41, are shown with transition conditions. One subcycle is associated with each of these states and must be fully executed before the next state of the main cycle is invoked, and it in turn invokes the next subcycle. The subcycles provide the link to the starting logic since their statuses trigger control of the valves and motors, set acknowledgment signals, and actuate timing circuits and counting circuits.

Thus, the subcycle "lubricate gear ring" is associated with the state Z36. As soon as Z36 = High, this subcycle continues the assembly process and initiates the required

functions, e.g., activation of the motor of the lubricating mechanism. While states Z71 through Z74 are being executed, Z36 remains High. As soon as Z74 = High and the initiator B28 = Low (grease gun is put aside), Z36 changes from High to Low and Z37 from Low to High, and the subcycle "lubricate gear ring" returns to the rest state Z70 = High.

This initiates execution of the next subcycle.

4. Monitoring Functions

The following functions and assemblies of the assembly cell are monitored:

- basic equipment settings: inserter, press, turning station, insertion mechanism, lift cylinder, and longitudinal feed slider at the beginning of the automatic process and before each additional assembly cycle
- presence of all tools necessary for the assembly cycle, such as hands, test apparatus, screwing tools, and grease gun
- presence of the palettes corresponding to the chuck type
- supply level of the component bins, and the vibration hopper, longitudinal conveyer, sprocket bin
- execution of all hand and hand exchange functions of the robot
- execution of the functions of the peripheral equipment
- operability of the approach switches
- pressure and supply level of the media involved in the assembly process.

In addition to the signal elements with monitoring functions, protective mechanisms have also been provided to prevent damage to the robot and to protect the operator during required manual interventions in the cell. To assure requisite product quality, the following features and functions are monitored by sensors during the assembly process and on the product:

- position and rotatability of the gear ring in its housing
- join ability of the flange screws in the housing
- position of the cover in the housing
- joinability of the driving wheel with the gear ring in the housing (meshing of gears)
- screw depth and starting torque of the screws for holding the pinion gear in place, and the cover and flange screws.

The monitoring of the assembly cell, the assembly process, and the quality of the connections obtained is performed automatically. In the event of error, the assembly cell goes into the operating state "STOP" for the robot or "NOT-AUS." The operating state robot "STOP" is triggered by errors which cannot result in damage to the assembly cell. The control situation for the functional elements of the peripherals is retained. After error elimination, the assembly process can be continued from the point at which it was interrupted. For this, approximately 50 possible errors are displayed by the PC control. At a point in the assembly process

which is decisive for the quality of the products (verification of the seating and the smooth operation of the gear ring in the housing), the assembly cycle is automatically changed upon error identification, with the defective assembly eliminated by the industrial robot and operation continuing with a new assembly.

The operational state assembly cell "NOT-AUS" is triggered by actuation of the damage protection mechanism in the assembly head of the robot, by unauthorized opening of the cell's safety door, by control-internal "NOT-AUS," and by actuation of a "NOT-AUS" button. PC and IRS programs are automatically reset to the starting status when "NOT-AUS" occurs.

5. Operator Control and Display Functions

Operator actions must be performed by the operator of the assembly cell:

- during operation in the operational state "Setup operation,"
- during creation of the starting state of the assembly cell for automatic operation, and
- in the event of error, during error elimination.

To work in the operational state "setup operation," the controller must be switched to "setup." Selection of the subfunctions of the peripheral assemblies is effected through activation of the operator control elements installed on the control panel of the control cabinet (Figure 5) and on the press frame outside the working area of the robot.

Errors which have resulted in robot "STOP" or assembly cell "NOT-AUS" are signaled with error lights and translated by an error number on the service unit of the PC (Figure 5). Error text and error numbers are summarized in an error list.

In the event that the assembly cell must be entered for error elimination in the STOP state during automatic operation, a control function is implemented by means of which the safety mechanisms on the cell door can be by-passed by a key switch. The robot can then execute movements only at minimum speed. If fewer than a specified minimum supply of components are present in the component bin, this fact is signaled. The robot does not go into the STOP state. Thus, the operator can fill the component bin without interrupting the assembly process. The robot only goes into the STOP state shortly before the component bin is completely empty.

6. Summary

Using the example of a flexibly automated assembly cell for assembling lathe chucks, the article describes control engineering solutions typical for the control of such

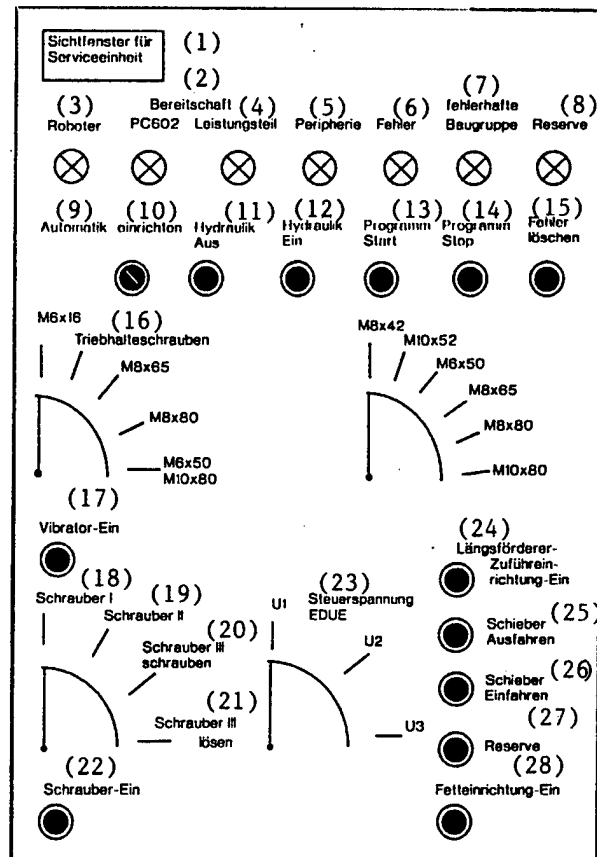

Figure 5. Operator controls

Key: 1. Service unit display window—2. Robot—3. Ready—4. Power component—5. Peripheral—6. Error—7. Defective Assembly—8. Spare—9. Automatic—10. Setup—11. Hydraulics on—12. Hydraulics off—13. Start program—14. Stop program—15. Clear error—16. fastener screwdriver—17. Vibrator on—18. Screwdriver I—19. Screwdriver II—20. Apply torsion to screwdriver III—21. Release screwdriver III—22. Screwdriver on—23. Control voltage, EDUE = Direct energy conversion unit, U = conversion—24. long feed feeding device—25. extend sliders—26. Insert sliders—27. Spare—28. Lubrication mechanism on

assembly cells. Emphasis is placed on extensive monitoring both of the assembly process and of robot and peripheral functions. Additional significant features are extensive protection against damage and the error identification system.

Bibliography

1. Neubert, G.; Walter, U.; Kunze, W.; "Flexibly Automated Assembly Cell for Lathe Chucks," FERTIGUNGSTECHNIK UND BETRIEB, Berlin, Vol 39 No 7, 1989, pp. 405-408.

Germany: Assembly Automation Using RoVis 8 Image Processing System

90WS0084A East Berlin FERTIGUNGSTECHNIK UND BETRIEB in German Jul 90 pp 405-407

[Article by Dipl.-Eng. W. Deutsch and Dipl.-Eng. L. Pfeil, Robotics Engineering of the ZIM/AdW, Automation Institute: "Assembly Automation With Image Processing System"]

[Text]

0. Introduction

Image processing systems are gaining increasing importance for production automation and especially for the use of flexible industrial robots (IR) in assembly. They are increasingly assuming tasks of recognition and classification of parts as well as detecting their position in the image field.^{2,3} This use in the automation process has been stimulated by suitable cost-effective image sensors such as video cameras and one- or two-dimensional CCD cameras and by inexpensive memory technology and microprocessors.

The modular binary image processing system RoVis 8 for the practical use of image processing sensors for guidance of industrial robot movements was developed at the Robotics Engineering School of the VEB Combine ZIM/AdW in the GDR. The article shows the use of this image processing system as a visual sensor for control of an IR using the example of the automatic assembly of automobile wheels.

Task Definition

The task consists of carrying out the assembly of automobile wheels using an industrial robot under laboratory conditions. For the automatic placement of a wheel on a wheel hub, exact knowledge of the position and orientation of both objects is essential. This problem can be solved for the wheel through careful prepositioning; the corresponding data for the hub must be determined using appropriate sensors.

The objective of the investigations was to develop a solution for wheel assembly based on the IR principle. Additionally, judgments were to be made concerning image field design, the time requirement for image processing, and the accuracy of the position detection.

2. RoVis 8 Image Processing System

2.1 Hardware Structure

Figure 1 presents the hardware and software structure of the RoVis 8 image processing system. To meet the demand for a low-cost system with minimal hardware requirements, the image processing system was designed so that any microprocessor capable of running under CP/M 80 with a K1520 bus and any CCD camera with CCIR standard video signal output can be used.

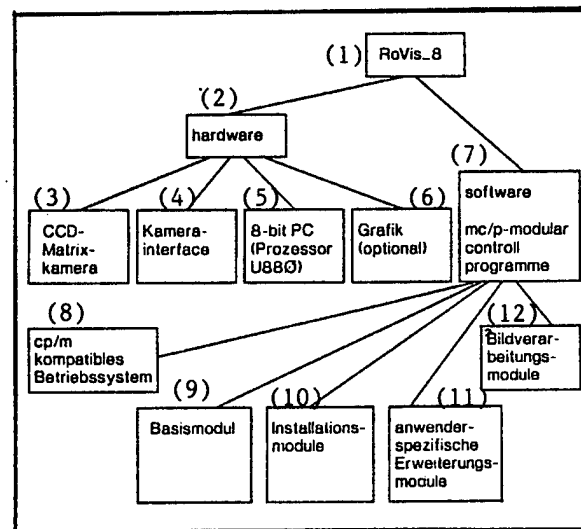

Figure 1. RoVis 8 Image Processing System

Key:—1. RoVis 8—2. Hardware—3. CCD matrix camera—4. Camera interface—5. 8-bit PC (U880 processor)—6. Graphics (optional)—7. Software MC/P-modular control program—8. CP/M-compatible operating system—9. Basic module—10. Installation module—11. User-specific expansion module—12. Image processing module

The camera interface (preprocessing card) for the CCD matrix camera handles the binary coding of the image, run-length coding, and the geometric image correction necessary because of the pixel geometry in the video in real-time.

This interface was developed at the AdW. Graphics are needed primarily for training and demonstration purposes.

2.2 Software System

The software system of the RoVis 8, MC/P (modular control program), consists, as Figure 1 shows, of mutually independent loadable modules. Their modularity permits simple configurability for adaptation to varied tasks without exceeding the storage limits of the respective computer. This avoids the disadvantage typical of large software systems of the difficulty in adapting the individual components and simplifies incorporation of user-specific expansion modules.

Components of the MC/P are the basic module CP (command processor), the module required for installation of the program system (installation module), and the task-based image processing module (processing module). Creation of task-based program systems is supported by extensive menu help, a system editor, and a user source program interpreter.

The task-based program system created for wheel assembly works with a new customized module created for it. In the first step, an object preselection from the

objects detected in the camera's image field is performed with the help of a scalar characteristic magnitude.

In the second step, the position of the wheel bolts is determined through the comparison of structural characteristics (geometric relationships). From the coordinates determined for the four wheel bolts, the position and orientation of the wheel hub are calculated.

Image Field Design

To produce binary images which are relatively simple to process, relevant characteristics of the object must be highlighted by appropriate contrastive illumination of the remainder of the object structure. For this, a task-specific design of the image field and appropriate illumination in the form of transmitted light, reflected light, or structured light are usually required.

The investigations were performed with the modes of reflected light illumination presented in Figure 3 because transmitted light could not be used for technical reasons.

Bright field illumination and ring field illumination as well as illumination parallel to the optical axis yielded inadequate contrast for binary processing.

The laboratory experiments performed according to selected criteria for these modes of illumination using the reflected light method revealed that reliable detection of the position of the black wheel bolts on the black hub was impossible. Therefore, tests were performed with optical filters and coloration of relevant parts of the object.

It was found that no significant improvement could be obtained by using filters, but that a color contrast of the wheel bolts in conjunction with dark field illumination yielded good results. From a technical standpoint, many ways of increasing such contrast are conceivable, such as modification of the assembly technology (preventing the painting of the bolts) or design modifications (holes appear black against a bright surface).

It was possible to minimize reflection phenomena on the bright metal brake disc and the similarly bright brake caliper through the choice of the illumination mode. Thus, on the CCD image sensor, the wheel hub was dark, except for the parts of the surfaces illuminated by unevenness or reflections, and the white painted ends of the wheel bolts, on which the light was diffused, were clearly marked.

4. Structure and Testing of the Solution Based on the IR Principle

4.1 Structure of the System Based on the IR Principle

The solution based on the IR principle produced for testing the basic operations of the assembly of automobile wheels with a user-specific image processing system consists of:

- ZIM 15 with IRS 701

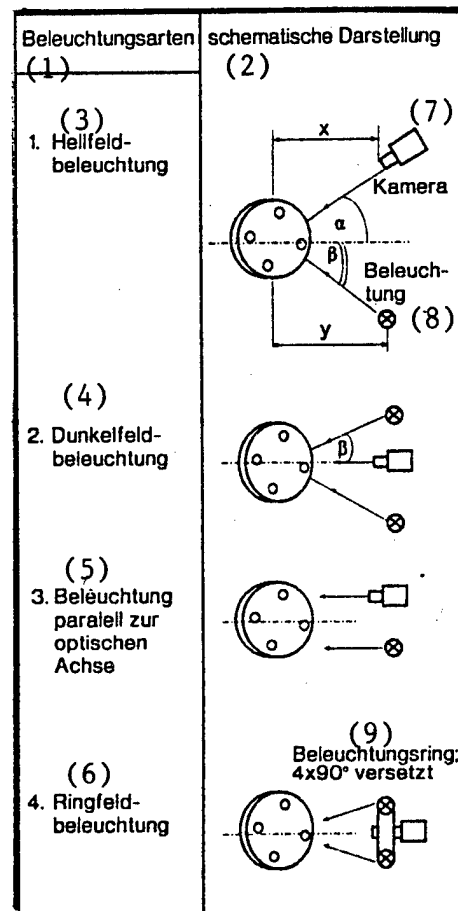

Figure 3. Illumination modes for the reflected light procedure

Key:—1. Illumination modes—2. Schematic representation—3. Bright field illumination—4. Dark field illumination—5. Illumination parallel to the optical axis—6. Ring field illumination—7. Camera—8. Illumination—9. Illumination ring: staggered at intervals of 90° [4 x 90 degrees for a full circle]

- RoVis 8 image processing system, see section 2.
- gripper
- mechanical devices for holding the auto axle and specified preparation of the wheel rim.

Coupling and Testing of the Image Processing System With IR

The CCD matrix camera and the illumination equipment were positioned at the foot of the robot. This results in a fixed relationship between the coordinate system of the image processing system and the IR, and the CCD matrix camera is located in the area safe from collision outside the field of motion of the effector. For the coupling between the image processing system and the IR, a serial interface (IfSS current loop) was used. The program used in the IRS [robot control] to tie in the

image processing system and the MC/P module "ROBOT" make it possible to use the image recognition system simultaneously as a terminal for the IRS.

The assembly process was initiated through the gripping of the prepositioned automobile wheel rim by the IR. Then, the IR with the CCD matrix camera arranged at the robot foot was positioned so that the wheel hub was within the image field. The CCD matrix camera was activated by the program running in the image processing system and the image processing routine was initiated. The wheel hub position parameters detected were transmitted to the IRS as focal coordinates and the orientation angle of the wheel bolts. After the positioning of the wheel rim using the position parameters received by the IRS, the properly positioned placement of the automobile wheel rim occurred. The pressure applied was measured by a force sensor located on the IR wrist.

The accuracy of measurement obtained with the image processing system was +/-0.5mm for position detection and +/-0.3 degrees for the orientation angle. The time required for determination of the position parameters beginning with the instruction from the IRS and ending with the termination of the data transmission to the IRS was 0.4 to 1 second depending on the available image quality. Both the accuracy obtained and the processing time meet the requirements of this assembly process.

5. Summary

The article points out the possibilities for use of binary image processing systems in the automation of assembly tasks. It was demonstrated that along with technology suitable for automation, binary image processing represents an economical alternative to gray-scale processing with its large component of special hardware. To this end, the RoVis 8 binary image processing system was developed for cost-effective, multipurpose use for process automation in the Robot Engineering School ZIM/AdW.

A principle solution for sensor guided wheel assembly was created by coupling a ZIM15 IR with an image processing system.

Bibliography

1. Heuer, G.: "Modular CCD Matrix Camera System MKS 22/1," BILD UND TON, Vol 40 No 2, 1987, pp 52ff.
2. Schoenborn, W. et al.: "Part and Position Recognition With the MAVIS System," BILD UND TON, Vol 38 No 12, 1985, pp 357ff.
3. Wlocka, K.: "Visual Components of '3rd Generation Robots'," Research report, ZKI, Berlin, 1985.

LASERS, SENSORS, OPTICS

Bremen Firm Develops Portable Laser for Ship Construction

90WS0106B Duesseldorf HANDELSBLATT in German
13 Sep 90 p 22

[Article by Bernd Ladiges and Wolfgang Karsten: "CO₂ Lasers in Containers for Flexible Use: Ship Construction/Portable Laser Cutter Research Project"; first paragraph is HANDELSBLATT introduction]

[Text] Hamburg, 12 Sep—Laser cutters offer materials processing capabilities difficult to obtain with conventional processes. Consequently, in many areas of industrial production the technically superior, more rational, and therefore more economical use of laser cutting has been commonplace for some time. Ship construction has until now been an exception.

Previously, it has been necessary to cut the large metal sheets used in ship construction by traditional means, for example, by flame or plasma-arc cutting, since there was no special laser technology for the oversized sheets typical in ship building. To remedy this situation, several northern German firms initiated a joint research project to develop a complete laser cutter system for the special requirements of ship construction.

Under the leadership of Schichau Seebeckwerft AG (SSW) of Bremerhaven, participants in the project supported by the BMFT [Federal Ministry for Research and Technology] include the Bremen Institute for Applied Radiation Technology (BIAS), the Bremen company Optische System Technik, and the Hamburg CO₂ laser construction specialist Rofin-Sinar Laser GmbH. The project is attempting to extend the advantages of laser cutting—limited introduction of heat with resultant dimensional accuracy—in the future to ship construction. The possibility of using lasers to cut large metal sheets of structural steel, aluminum, and chrome-nickel steel, where for technical and economic reasons the previous maximum sheet thickness has been 16 mm, is being investigated.

The definition stage yielded a few difficult problems such as the long beam paths of over 20 m peculiar to ship construction which necessitate spatial readjustment of the beam position. These problems have been overcome by means of new beam position sensors and adaptive mirrors and by the development of an innovative large gantry system with a track width of 8.5 meters, used in conjunction with a modified 6-kW-CO₂ laser.

With its high beam quality and variable reflecting telescope, the laser beam can be transmitted and efficiently controlled over a distance of 30 m—this guarantees uniform cutting quality over the entire work area. To assure trouble-free operation throughout the shipyard, the laser is installed so as not to vibrate inside a

hermetically sealed air-conditioned housing. This compact laser unit can be moved without major assembly and disassembly to other desired locations.

An important phase of the project was successfully completed in February 1990 when Rofin-Sinar delivered the 6-kW laser source described above to BIAS for further development of the complete system. The model RS 600 RF is a high-frequency-excited CO₂ laser, whose output stability and controllability as well as its beam characteristic meet project specifications.

Since the laser source, control box, and operator controls are incorporated into a special closed container (9.12 m x 3 m x 3.35 m), the laser system is mobile and can be used in extremely varied locations. The gas supply is handled via solidly mounted pressure reduction units from steel bottles installed on the container. An air-conditioning system which uses recirculated air without introducing dust-laden shipyard air is also solidly installed.

In the coming months, BIAS will continue the development required for the external beam control and connection to the large gantry system. But it is already fair to assume that laser technology will soon be used in ship construction—not in the least because this CO₂ laser system can also be used flexibly for other laser-based materials processing tasks.

Dutch Center Develops Free-Electron Laser

91AN0035 *Rijswijk POLYTECHNISCH WEEKBLAD*
in Dutch 30 Aug 90 p 3

[Article: "New Research Center Shows Free-Electron Laser"]

[Text] Last week, Minister of Economic Affairs Andriessen inaugurated the Dutch Center for Laser Research (NCLR) at the University of Twente. In this center, the [university's] Quantum Electronics department is cooperating with Ultra-Centrifuge Nederland NV (UCN). At this inauguration, the NCLR was already able to boast of its very first achievement: Some of its staff members had indeed developed the first free-electron laser in the Netherlands.

In a free-electron laser, the laser beam is emitted by free electrons. In traditional lasers, the beams are generated by atom-bound electrons. The free-electron laser fits well into the development of more powerful lasers with more easily definable wavelengths. In Europe, only a few such lasers are operational so far.

Partners

The Quantum Electronics department of the University of Twente and UCN have been cooperating on laser research for about one and one-half years now. Since the development of lasers is becoming increasingly complicated and therefore more expensive, while the research

subsidies by the Dutch Government are constantly shrinking, cooperation with industry is becoming imperative.

At the moment, UCN is still the only partner, but now that cooperation has become formal, the aim is eventually to involve more companies in the university's laser research. According to business manager Eng H.J.G. van Heel, the rights, obligations, and competences of participating companies are determined only after mature consideration. At the opening of the NCLR, Minister Andriessen announced that the center would "most likely" be granted a subsidy from his ministry. According to van Heel, this contribution would amount to 900,000 guilders at the most.

MICROELECTRONICS

EC Launches Open Microprocessor Initiative

91AN0011 *Paris ELECTRONIQUE HEBDO* in French
20 Sep 90 p 21

[Article signed F.G.: "Europe Finally Ready To Adopt Open Microprocessor Architecture; EC Commission Adds Finishing Touch to an ECU 375-Million Project To Provide Europe With an Original Microprocessor Architecture by the End of the 1990s"]

[Excerpts] It was believed to have been definitively buried after the successive defections of Siemens, Philips, and Matra MHS; now it has resurfaced. The Commission of the European Communities in Brussels is currently adding the finishing touches to what has become, over time, the Open Microprocessor Initiative (OMI), in other words, the project to develop a pan-European microprocessor by the end of the decade. This ECU 375-million project is apparently at last open to companies from non-EC countries as well as to non-European companies. Its aim is to give "Europe" the general-purpose microprocessor it will need for the post-RISC [reduced instruction set computer architecture] era, which is expected to start in 1995. This microprocessor should make use of the features of ultra-fast context changing and dynamic instruction prediction in order to allow virtual processing, virtual memory, and virtual communications in general-purpose parallel processing applications using up to thousands of processors. This microprocessor could be a 64-bit device, but the choice has not yet been definitively made. [passage omitted]

Open to Non-Europeans

The OMI project is part of the EC's Third Framework Program for Research, an ECU 5.7-billion project which should run during the 1990-1994 period. This program earmarks ECU 2.221 billion for information and communication technologies alone (ECU 1.352 billion for information technologies).

Companies from non-EC countries will be able to take part, but will not be able to claim subsidies. The aim of opening up the program to non-European companies, is to enlarge the potential user base and also have several European sources, but not only for a microprocessor of European architecture: The main aim is simply to break free in the future from American—and potentially Japanese—domination in this sector.

However, the program is not limited to the development of components and macrocells. In fact, the major part of it quite rightly concerns development: of development tools, systems software, and applications software. This microprocessor should be compatible with Unix, the best-selling operating system.

Several projects are being looked into: for the development of a microprocessor architecture; of a general-purpose MIMD (multiple instruction multiple data) machine; and of processor macrocells. The Inmos Transputer, like the Acorn Arm, could be the starting point for macrocells. It is also impossible not to think of Otto Mueller's Hyperstone, which up till now has only struck lucky on the other side of the Atlantic and which could also be a starting point for microprocessors "made in Europe."

For its part, SGS-Thomson has apparently already decided to develop an OMI-type microprocessor to take over from the second generation of Transputers now being developed under the code name H1, of which more later.

JESSI Wafer-Scale Integration Project Approved

*91AN0007 Paris ELECTRONIQUE HEBDO in French
6 Sep 90 p 18*

[Unattributed article: "Europe Leads the Way in Wafer-Scale Integration"]

[Text] Anamartic [UK], Siemens [Germany], and Bull [France] have entered into an agreement to develop new data storage units based on wafer-scale integration technology developed by Anamartic. Moreover, the project has just received \$11.6 million in JESSI [Joint European Submicron Silicon Initiative] funding over four years. Equal amounts of funding will be contributed by the governments of the companies concerned and by the companies themselves. Siemens will bring to the project its expertise in the field of semiconductor manufacture, in particular that of 4-Megabit and, later on, 16-Megabit dynamic random-access memories (DRAMs). Bull will be responsible for wafer encapsulation and for developing packaging systems optimized for computer systems. Both will be basing their work on the wafer-scale integration technology developed by Anamartic which, up till now, has used 1 Megabit DRAMs manufactured by Fujitsu. The British company has developed a technique for interconnecting chips directly onto the wafer as well as software, which in theory makes it possible, using 1-Megabit chips, to consider integrating 25 Megabytes on a wafer 150 mm in diameter. The first data storage

units based on this type of memory, which were marketed by Anamartic at the end of last year, used eight 150-mm wafers, each integrating 20 Megabytes. The move to 4-Megabit and then 16-Megabit memories should make it possible to increase capacity considerably (initially to 1 gigabyte) while keeping the small size (that of an 8-inch hard disk).

Nokia Develops Flat Screen Concept

*91AN0055 Paris ELECTRONIQUE HEBDO in French
27 Sep 90 p 21*

[Article: "Electron Beam Flat Screen Being Tested at Nokia"; 11-inch screen developed by Nokia laboratories matches cost and resolution of cathode ray tube screens, but is only 6 cm thick.]

[Text] The Japanese are not the only ones working on flat-screen television technology. At Nokia's Esslingen laboratories in Germany, a team of engineers has developed such a concept based on a parallel electron beam matrix and a beam deflection grid that avoids the use of a mask. According to Nokia, this concept should allow the production of flat screens at the same cost as cathode ray tube screens of the same size.

An 11-inch diagonal model was developed with a 6-cm thick tube. The electron source is a so-called inverted triode system with a segmented rear electrode and a 30-filament matrix constituting the cathode. The segmentation of the rear electrode makes it possible to control brightness and purity of the white.

The anode field and luminophors are the same as those used in cathode ray screens and provide comparable brightness characteristics.

Steel Rather Than Glass

A second series of control elements, superimposed on the first, includes the anode, the line selection, and the deflection electrode. The device is completed by an electron acceleration region. The information provided by Nokia does not allow a more detailed analysis of the principle.

The color raster is achieved by a screen printing process. For the tube, with the exception of the screen, the designers selected steel (the same as that used for the masks in conventional TVs) rather than glass, not only for reasons of cost but also on grounds of feasibility. Since the expansion coefficient of glass and that of the electrodes are substantially different, the resulting mechanical stress could be unacceptably high.

The 11-inch screen has a resolution of 276 lines, each consisting of 388 pixels, which makes a total of 107,088 pixels. The distance of 0.57 mm between the pixels, or 0.19 mm between the color points, provides the same resolution as that obtained with a cathode ray tube of comparable size (14 inches).

Principle of the Nokia Flat Screen

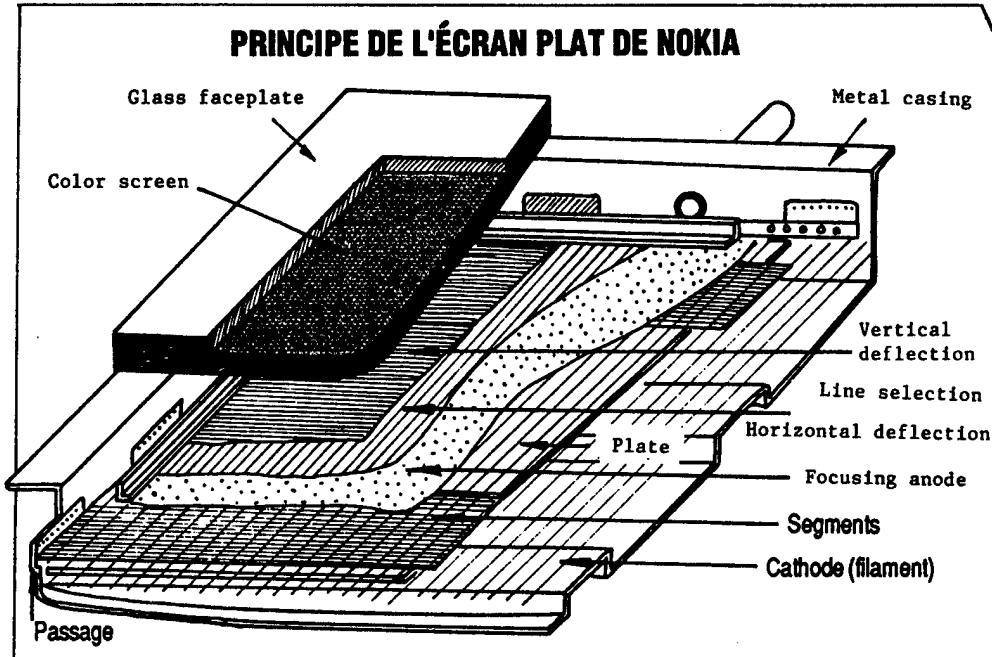

The tube developed by Nokia is made of a matrix of filaments forming the cathode and various signal modulation, beam control, and deflection elements. A color raster is fixed to the glass faceplate by serigraphy.

Belgian IMEC Laboratory's Achievements Reviewed

0.25-Micron Optical Lithography

91AN0034A *Kalmthout INDUSTRIE in Dutch*
Oct 90 p 92]

[Boxed article by Dirk Denoyelle: "World Record: 0.25 Micron Optical Lithography"]

[Text] In January, the "Micropatterns" group of the Interuniversity Microelectronics Center (IMEC) succeeded in etching 0.25-micron-wide lines in a photo resin by implementing an optical process based on exposure through a mask. A 248-nanometer-deep UV-exposure method was used. The photo resin was a Plasmask developed under the DESIRE [Diffusion Enhanced Silylating Resist] project by the Belgian company UCB-Electronics.

The process has been developed within the European ESPRIT Drydel project, which aims at reducing the line widths of relatively cheap optical lithography systems to 0.3 micron; an objective which has now been achieved.

This work is important with a view to the possible development in Europe of 64-Mbit dynamic random-access memories (DRAMs). For Flanders, this result paves the way to the development of 0.5-micron application-specific integrated circuits (ASICs), which could be used by the Belgian Microelectronics Technology (MIETEC) company, for instance. It also constitutes a considerable incentive for companies such as Cobrain (etching equipment) and UCB-Electronics.

Within the framework of this project, IMEC installed a deep-UV stepper, i.e., an exposure apparatus, in May 1990.

This makes IMEC the first European laboratory to own such a machine, enabling it to maintain its worldwide leading position in microlithography.

0.7 Micron Chip Technology

91AN0034B *Kalmthout INDUSTRIE in Dutch*
Oct 90 p 92

[Boxed article by Dirk Denoyelle: "0.7-Micron Chip Technology"]

[Text] In early February, IMEC developed a 0.7-micron CMOS technology for chip manufacture, whose successful operation was proved by a truly operational 16K static random-access memory (SRAM) built in its own laboratory.

This entirely in-house developed technology is characterized by a very high performance (transistor speeds), combined with great simplicity: Only 11 masks are used in the dual layer metal (DLM) process. Comparable American and Japanese processes require as many as 14 to 16 masks. Since the production cost depends on the

processing time, which in turn depends on the number of masks, the new process is obviously less expensive. In addition, this process is perfectly suitable for down-scaling to a 0.5-micron technology.

All this has resulted in an agreement with MIETEC, which is going to use this process to manufacture advanced prototypes beginning in the first quarter of 1991.

Superconducting Chips

91AN0034C *Kalmthout INDUSTRIE in Dutch*
Oct 90 p 94

[Boxed article by Dirk Denoyelle: "Superconductivity Compatible With Chips Manufacture"]

[Text] It has been possible for quite some time now to produce high-temperature superconductors, which become superconductive at the temperature of liquid nitrogen (= 179 Kelvin degrees). However, because of the high temperatures required for producing the correct yttrium-barium-copper oxide, the manufacture of superconductors, on the one hand, and chips, on the other, have been irreconcilable so far. With its own patented apparatus, IMEC has now shown that they can indeed be reconciled. The method consists in depositing a superconducting ceramic material, which has previously been vaporized in the same reactor by means of an intense laser beam, onto a hot substrate. In this reactor, deposition takes place in an ionized gas or oxygen plasma environment at 600 degrees Celsius, a temperature which is compatible with silicon processing, whereas previously 800-degree temperatures were necessary to achieve oxidation. In addition, the method is not limited to the YBaCuO family. According to the researchers, any material can be processed, but the toxic thallium compounds are left out of the picture.

Philips France Develops 'Learning' Neural Chip

91AN0014 *Rijswijk POLYTECHNISC*
TIJDSCHRIFT in Dutch Aug 90 p 5

[Excerpts] In the field of neural networks, which involve fast processors with many interconnections, new applications and methods are continually being found. Examples are: television image compression, speech recognition, or fault diagnosis in complex communications networks. The French Philips research organization, the Philips Electronics Laboratories (LEP), has recently demonstrated an all-digital very-large-scale integration (VLSI) circuit with a learning system integrated onto the chip. They have thus shown that real-time processing of complex signals can be done using a simple network of neural signal processors.

New Chip

The French LEP has recently designed a VLSI chip for neural network technologies called "L-neuro" (learning neurochip). The most important property of L-neuro

chip is its integrated learning capacity. All the necessary learning rules can be programmed into the general learning unit. The potential of the L-neuro were demonstrated recently during a symposium in London. The demonstration involved the use of a neural algorithm to perform a principal component analysis (PCA). This consists in defining the relevant characteristics of an image, through which image compression becomes possible. The PCA algorithm requires the learning of these relevant characteristics, which is done by L-neuro in real time. The L-neuro is based on the complementary metal-oxide semiconductor (CMOS) principle. In addition, the chip contains a random-access memory (RAM) for the storing of 1,024 neural connections. Average response time for updating the 8-bit neuron code is 1 microsecond, irrespective of the size of the network. These results however, have been produced only at the laboratory research level.

French Labs Cooperate in Submicron Research

91AN0009 Paris *ELECTRONIQUE HEBDO* in French 13 Sep 90 p 15

[Text] The Materials Physics Laboratory (LPM) of the National Institute for Applied Sciences (INSA) in Lyon, the National Center for Scientific Research (CNRS), and the Norbert Segard Center of the National Center for Telecommunications Studies (CNET) have just decided to pool their research expertise on materials and components for microelectronics. According to this collaboration agreement, renewable after a four-year period, CNET and LPM are to carry out joint research in the field of microstructures for very-large-scale-integrated circuits. Within this framework, a mixed team of eight researchers from LPM and CNET will be working in CNET premises under the supervision of LPM. It will work on projects decided on by both partners, such as characterizing and analyzing the performances of submicron MOS structures developed at the CNET; and conducting research into and proposing new structures for generations of technologies of 0.5 micron and smaller. The microstructures will be developed at the CNET facility in Grenoble; LPM's contribution will mainly be in physics research and characterization.

Germany: Operation, Applications of Domestic ASIC's Described

U5301 FC-302

90WS0102A East Berlin *RADIO FERNSEHEN ELEKTRONIK* in German Aug 90 pp 482-487

[Article by Dipl.-Eng. Hartmut Korsitzky, Dr.-Eng. Thomas Foerster, and Dipl.-Eng. Jens Norden: "ASIC

U5301 FC-302 for Data Logging"; first paragraph is RADIO FERNSEHEN ELEKTRONIK introduction]

[Text] The gate array circuit U5301 FC-302 was developed at the Institute for Space Research Berlin specifically for an optoelectronic scanner for remote earth reconnaissance for use on satellites and manned space stations. Despite its specific intended use, this is a universally applicable controller for timely serial logging of data in multisensor systems with CCD [charge-coupled devices]-line sensors. Using these ASIC's [Application Specific Integrated Circuit], compact and flexible data logging systems with low power demand can be produced; they are presented in this article.

With the development of the MOS (modular optical scanner) complex, the GDR is continuing a line of research for remote earth reconnaissance begun with the multichannel spectrometers of the MKS series on the Interkosmos 20 satellites (November 1979), Interkosmos 21 (February 1981), and the Salut and Mir orbital stations. As an optoelectronic scanner, the MOS scanner complex will deliver digital images of the earth's surface. The data continue to be used for oceanic research. Additionally, they are expected to contribute to environmental monitoring and to solutions of ecological problems. CCD lines of the type L172C (Television Electronics Works) are used for image recording. The specification requires a flat arrangement with four L172C CCD line sensors and a 3-D arrangement with 13 L172C CCD line sensors¹ (see figure 1), with both provided in hybrid technology. On the basis of this specific problem, significant requirements for the selection electronics of systems with multiple CCD line sensors can be formulated:

- programmable exposure time control
- selection and evaluation capabilities for different types of CCD lines
- programmable control of the readout of the electrical charges from the sensors
- preparation of control pulses for signal detection and signal processing (scanning pulses for blank and signal values, pulses for creation of macrodata, trigger pulses for the A-D converter, strobe pulses for external buffering of digitized data)
- preparation of signals for selection of data storage or correction storage
- a high level of functionality as a prerequisite for creation of a family of instruments
- minimization of weight, volume, and space and power demand of the complex of instruments
- high reliability
- maximum independence of operation after programming.

This large group of requirements suggested an ASIC solution.

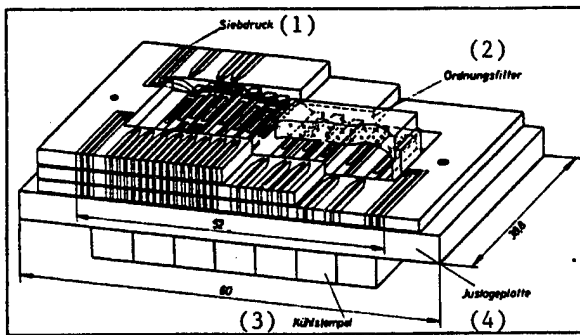

Figure 1. Focal Plane Module With Physical Layout of 13 CCD Line Sensors

Key: 1. Screen printing—2. Order filter—3. Heat sink—4. Adjustment board

Functional Range

Despite the specific intended use of the MOS project, this is a universally applicable controller for timely logging of data in multisensor systems with CCD line sensors (CLIC CCD line controller). All CCD line sensors produced in the GDR can be controlled directly by a driver.

Multiple circuits can be cascaded, with up to seven CCD line sensors driven and controlled by each CLIC.

A total of 18 control variables are available to the user to set functional and operational parameters of the circuit. Each control variable is entered in a specific CLIC register which applies it along with the corresponding register address to the CLIC data bus (write cycle). This permits adjustment of

- sensor control,
- sensor scanning,
- data selection, and
- control of data summary

to current operating conditions via software at any time during operation. With appropriate programming, the CLIC autonomously controls the entire signal gathering process. This includes: pixel signal logging, macropixel generation, triggering an A-D converter, and buffering the converted or corrected digital macropixel signal values in an external latch.

The capability of macropixel generation must be stressed. This enables selection of relevant data from the total data stream. Only these data are transmitted to the control computer.

The main assemblies of the CLIC (Figure 2) are

- programmable timer
- sensor control for as many as seven sensors
- job sequencing
- memory management
- input and output control

- cascade logic.

They are presented below to illustrate the mode of operation of the ASIC's.

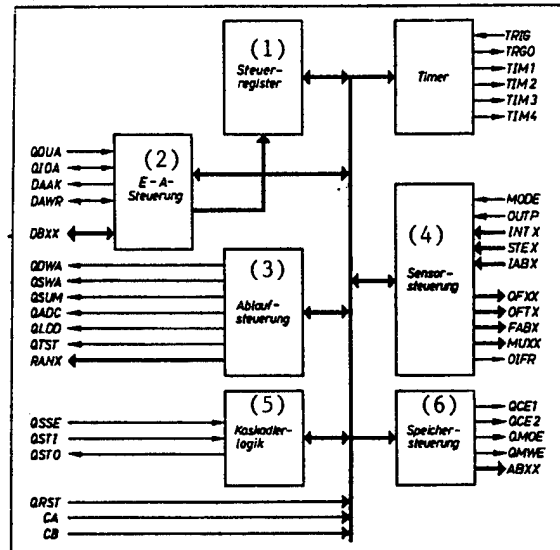

Figure 2. Schematic

Key: 1. Control register—2. I/O control—3. Job sequencing—4. Sensor control—5. Cascade logic—6. Memory management

Timer

Using the timer assembly (Figure 3), line sensor integration time control is possible². This permits electronic control of measurement time based on the sensors.

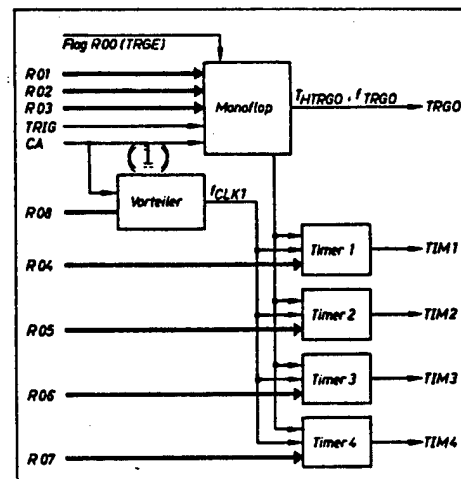

Figure 3. Timer Design

Key: 1. commutator

One programmable monoflop and four identical timer channels with a shared programmable commutator supply the necessary control signals. The timer assembly is timed by the system timing pulse CA [computer assisted equipment]. Thus it operates independently of the other assemblies of the CLIC. The output signals are designed such that they can be supplied directly to the inputs of the sensor control.

The monoflop can be operated both as a non-retriggerable monoflop and as a multivibrator, with the selection made by the external CLIC system timing pulse CA and the external trigger signal TRIG. The maximum counting capacity of the monoflop is $2^{24} - 1$ CA pulses. Timer channels 1 through 4 are selected by an integral internal pulse derived from the CLIC system timing pulse CA. This is prepared by a programmable commutator. The 8-bit-wide control information freely programmable for each of the timer channels determines the output pulse duty factor to the outputs TIM 1 through TIM 4.

TRIG— L-H active trigger input of the monoflop

TRGO— H-active output of the monoflop, primarily for control of the STEx-inputs of the individual sensor controls or the QSTI-input of the cascade logic

In the following, $x = 1$ through 4:

TIMx— Output timer channel x , primarily for control of INTx- and IABx inputs of the individual sensor controls.

Sensor Control

Sensor control consists of seven independent individual sensor controls with three inputs and three outputs each. It is timed by the system timing pulse CB and generates the signal OIFR common to all the individual sensor controls. By connecting the input OUTP the user specifies which driver (inverting or noninverting) he is configuring the CLIC for.

There are two drive modes for sensor control. Using the MODE input, a drive mode is selected in common for all individual sensor controls (Figure 4).

The CLIC reports the number of the respective active individual sensor control (0 through 6) in binary form at the outputs MUX0 through MUX2. The individual sensor controls may be used independently of each other to generate the control pulse sequences for CCD sensors. In minimal configurations, it is also possible to generate control signals for sensors even without programming the CLIC. In the following, $x = 0$ through 6:

OFXx	Output for timing the parallel transfer of sensor
OFTx	Output for timing the serial transfer of sensor x
FABx	Output for additional exposure time control of sensor x

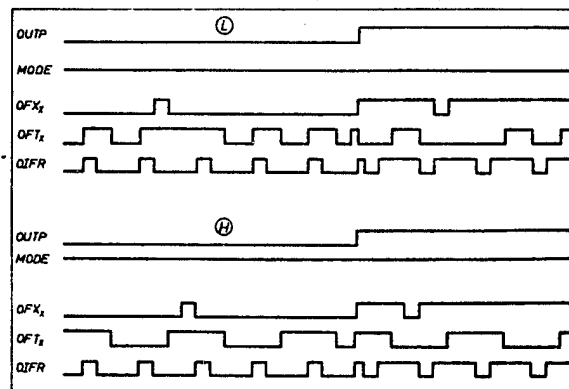

Figure 4. Signal Activity OFXx, OFTx, and OIFR as a Function of MODE and OUTP

OIFR	Output for common reference signal timing of all sensors
MUX0 through MUX2	Outputs for sensor selection
INTx	L-H active input to trigger the parallel transfer pulse OFXx of sensor x
STEx	H-active input to stop the serial transfer pulse OFTx of sensor x
IABx	H-active input to trigger the control signal FABx of sensor x
MODE	Input for selection of the common control mode for all sensors
OUTP	Input for definition of the output signals for all sensor control outputs.

Job Sequencing

The CLIC operates either in the programming mode (QOUA = H) or in the controller mode (QOUA = L). After resetting (QRST = L), the circuit is in the programming mode.

Data logging can be initiated selectively using the signal QSSE or QSTI. The IC then operates as a controller in the controller mode. In a logging cycle, the job sequencing permits the relevant optical data from all released sensors to be read once for each sensor. Then the CLIC quits the controller mode and returns to the programming mode. At this time, it can be reprogrammed or restarted.

The data evaluation concept is based on the principle that the user defines a measurement field whose data are completely mapped on the sensors. The CLIC supports the selection of the desired data in two stages:

1. All sensors cycle through a programmable offset together until they are in the vicinity of the measurement field (coarse electronic adjustment).

2. Later, a sensor-driven approach to the limits of the measurement field takes place (fine electronic adjustment).

Sensor data are not evaluated in either of the two cases. After logging starts, the coarse electronic adjustment is introduced. Then, one after another each sensor undergoes fine electronic adjustment and the logging of the data from this sensor takes place.

All sensor or system parameters for data logging are freely programmable. It is also possible to specify by programming that only selected sensors will be included in the data logging. This permits purposeful selection of specific data. For data logging, signals are generated for scanning and summarizing individual data into macrodata as well as for subsequent data processing. These are summarized here:

QDWA/	L-active pulse for blanked value scanning (pixel-based blanked values with CCD sensors)
QSWA	L-active pulse for individual signal value scanning (pixel-based blanked values with CCD sensors)
QSUM	L-active pulse for summarizing single or multiple individual data into macrodata
QADC	L-active pulse for triggering of analog-digital converter to digitize macrodata
QLDD	L-active pulse for loading digital output data from the A-D converter into the buffer memory.

Memory Management

Parallel to the data logging cycle, sensor-based memory addresses are generated for each macrodatum including the associated memory control signal. A variety of selection modes can be programmed for up to two memory blocks of 64 Kbytes each. Without additional external switching, SRAMs (e.g., 6516, 6564, among others) can be selected and driven directly. The following signals are generated:

QCE1	L-active chip enable signal for the first memory block
QCE2	L-active chip enable signal for the second memory block
QMOE	Common L-active output enable signal for both memory blocks
QMWE	Common L-active write enable signal for both memory blocks
AB00 through AB15	Memory addresses

Input and Output Control

The programming of all the 18 internal registers and the writing and reading of the memory blocks as well as the organization of the data transfers from the data logging system are supported by control signals from the input and output controller. All inputs into the internal registers and all inputs and all outputs into the memory blocks controlled by the CLIC can occur only when the

ASIC is in the programming mode. The following are part of the input and output control:

QQUA	L-active output acknowledge signal for display of the bus query by the CLIC
QIOA	L-active bidirectional input-output acknowledge signal to indicate whether any data are at the bus
DAAK	L-active data acknowledge signal to indicate that digital data of relevant sensors buffered in the data logging system are reported
DAWR	H-active bidirectional data write pulse which controls transfer of the digital data buffered in the data logging system to higher level data logging or data processing
DB00 through DB15	16-bit-wide, bidirectional data port of the CLIC.

Cascade Logic

For control and evaluation of more than seven CCD line sensors, CLIC's are cascaded by linking their QSTO output with the downstream QSTI input. This permits readout of the sensors from CLIC to CLIC within a cascade.

Several CLIC's of a cascade can control common memory blocks. A variety of control outputs with open drain output stages can be linked via shared pull up resistors. If, for one CLIC, no sensors are free for data logging, the control is immediately sent on via the relevant circuit and thus the overall time required for data logging is minimized.

QSTI	H-L-active start input 1 for transition from the programming mode into the controller mode
QSTO	H-active control output to indicate the control mode. Delivers trigger signal for downstream cascaded CLIC control input QSTI
QSSSE	Select input to select the CLIC in the programming mode and start input 2 for transition into the controller mode

Figure 5 shows the proposed layout of the IC with the pin allocation of the QFP-124 housing.

Startup

Test Station Specifications

Twenty prototypes in untested condition were delivered from sample production. The manufacturer performed an LSSD structure test at approximately 1 MHz. Before the design can be released for production, a functional test must be performed under operating conditions. This includes a set of parameter tests as well as logical function tests based on the simulation results of the design. There are also functional tests in the system environment of the final product. The functional test is the responsibility of the ASIC user but without the Archimedes design system supporting simulation data preparation required for it. The requirement for exact reproducibility of the measurements and the variety of measurement sequences presuppose a completely computerized test cycle. The use of PC-supported lab test techniques is a cost effective solution for this problem.

Customized ASIC verification systems with simulator interfaces are more suitable. The adaptation of the components, which are located in 124-pin SMD housings with 0.635mm pin spacing (1/40 inch, fine pitch raster), takes place via a conformable mount on a carrier plate. The carrier plate makes contact via pluggable connectors on the load circuit⁵ with the load circuit recommended by the manufacturer. Figure 6 shows this arrangement.

Parameter Measurement Technology

The PC-AT used as the control computer has an IEC interface. Using the software package LABCON (lab controller), the measurement instruments connected via this interface can be programmed from a menu. The system is open on the top so that additional devices can also be integrated into it without difficulty. Figure 7 shows CLIC power consumption as a function of pulse frequency.

Logical Measurement Technology

Logical function tests are performed with a logical analysis system consisting of a word generator and a logic analyzer. The data of the connection simulation are converted into a hardwarelike data format according to certain criteria with regard to pin number, number of input sequences, pin group format, and simulation depth. The startup data base thus generated delivers bit patterns to control the word generator and, after performance of the logical measurement, contains the reaction pattern of the ASIC. Pin groups up to eight pins each contain either input, output, or bidirectional pins. For bidirectional and tri-state pins, the circuit-internal output enable signal is also included.

Using LABCON simulation data and measurement results can automatically be compared with each other. The results of the comparison can be displayed both as status tables and pattern diagrams on the PC screen. Printer output is also possible (See Figure 8).

All CLIC prototypes tested functioned reliably at system frequencies up to 15 MHz.

Macro Model

Task definition

The task is to create an algorithm for a series of control sequences and to implement it as a software model. This should result in the creation of a behavior standard for the design of the gate array which supports system design in the application of the circuit.

Implementation

The software model CLICmod⁷ was designed as an independently executable program with an integrated interface for user dialogue. The major problems in the implementation of the design were found in

- control of the timing of processes running simultaneously within a circuit and between several cascaded circuits
- management of the simulation results
- design of the user interface

User Interface

The user interface was implemented as a sequence of programming forms (Figure 9) which are presented to the user one after another on the screen. This imitates a part of the register structure of the circuit so that in preparation for the simulation (programming of the circuit) the user enters only the desired values "into the register." A group of circuit inputs (model inputs) are loaded with input sequences to define external conditions. The simulation results can be output as a pattern diagram (Figure 10) using the PATPRI program from the Institute for Space Research (IFK).⁸ PATPRI was also used during the design phase to transform simulation results from the table form generated by the Archimedes design system into pattern diagrams. The results can thus be more readily evaluated by the engineers.

Results

Using the software model, configurations of up to three cascaded circuits can be simulated. The reaction of all circuits to 67 outputs can each be calculated. Such a simulation with 30,000 time steps (= 30,000 system timing pulse periods) requires approximately 10 minutes of CPU time on a VAX-785 (DEC). CLICmod is available for users of the circuit.

Design Outlays

In the design of the CLIC, 100 percent of the flipflops and 69.5 percent of the combinatorial resources of the logic master U5301 were used. All 108 customer pins were used.

Development of the design was performed on a VAX-785 from Digital Equipment. The distribution of computer time among the individual tasks is shown in Table 1.

Table 1: Task-Related Computer Time Outlay

	Inactive terminal time in hours	CPU time in hours
Modelling	479	16.5
Circuit input	239	4.5
Logic simulation	595	77.0
Other support	434	7.0
Total	1747	105.0

In the evaluation of the CLIC design, a strategy for design preparation was developed at the IFK for future design projects. It assumes that the ASIC user must be assisted from the system idea all the way to the startup of

use of the circuit. In implementation of this strategy, two weak points in the designing of the gate array packet U5300 are obvious:

1. The software support of the Archimedes design system does not begin until the logic implementation phase. A behavior or system simulation including the tools for a design process beginning with it are not part within the scope of Archimedes.
2. If in addition to the LSSD structure test the user requires a functional test under real conditions based on his simulation results from the design, extensive software work is required because the preparation of simulation data for an ASIC verification system is not supported by Archimedes.

Because of this, the user is forced to create software accessories in addition to the design.

Application

To elucidate the mode operation of the CLIC, the logging of signals from an arrangement of four CCD line sensors is illustrated (Figure 11). Because of the technology-related tolerances of the line assembly, the sensor chips are actually parallel, but are pushed against each other in the lengthwise direction.

The integration time (exposure time) is controlled by the timer block. Its programming is not dealt with here since it has already been described in detail.⁴

In the example, the measurement field includes 32 individual pixels for each sensor. The individual pixels are to be combined into a total of eight macropixels per sensor. Detection of the macropixel values as well as their A-D conversion and transfer to a data logging system are controlled by the CLIC.

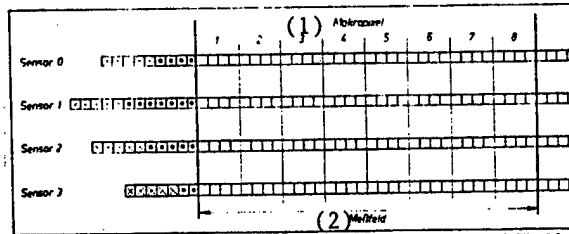

Figure 11. Representation of the Recording Conditions for a 4-Sensor Layout

Key: 1. Macropixel—2. Measurement field

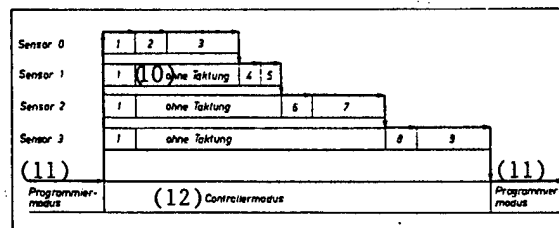

Figure 12. Cycle Pattern for Data Logging Corresponding to the Application

Key: 1. Common timing of all sensors—2. Fine adjustment of sensor 0—3. Data logging sensor 0—4, 5. Skipping of sensor 1—6, 7. Fine adjustment and data logging of sensor 2—8, 9. Fine adjustment and data logging of sensor 3—10. Without timing pulse—11. Programming mode—12. Controller mode

To guarantee detection of the first individual pixel in the measurement field in each case, a special adjustment phase is run jointly for all sensors and also individually for each sensor.

To satisfy the task definition, the parameters are programmed according to Table 2.

Table 2: Programming of the Parameters

Macropixel size = 4	Every 4 individual pixels are combined into a macropixel
Common offset = 5	All sensors are jointly pulsed by 5 pixels, without these individual pixels being evaluated
Offset 0: 4	Fine adjustment of sensor 0 by 4 individual pixels up to the limit of the measurement field
Offset 1: 7	Fine adjustment of sensor 1 by 7 individual pixels up to the limit of the measurement field
Offset 2: 5	Fine adjustment of sensor 2 by 5 individual pixels up to the limit of the measurement field
Offset 3: 2	Fine adjustment of sensor 3 by 2 individual pixels up to the limit of the measurement field
Number of macropixels per sensor: 8	By combination of each 4 sequential individual pixels into a total of 8 macropixels
Sensor release: 0, 2, 3	Evaluation and transfer of the macropixel data values of sensors 0, 2, and 3 to the data logging system

After the registers of the CLIC have been loaded, the transition from the programming mode to the controller mode after expiration of the integration interval can be enabled by triggering on QSTI (Figure 12).

First, all sensors 0 through 3 are prepulsed for a total of five individual pixels within the framework of the coarse adjustment (1). Then, a fine adjustment is performed for sensor 0 by four individual pixels while sensors 1

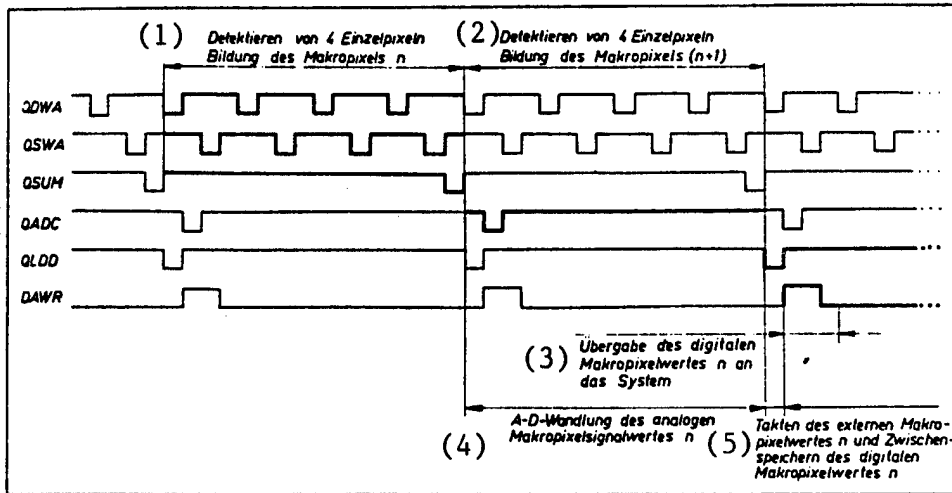

Figure 13. Output Signal Activity of the CLIC for Signal Value Logging Corresponding to the Application

Key: 1. Detection of 4 individual pixels, generation of the macropixel n—2. Detection of 4 individual pixels, generation of the macropixel (n+1)—3. Transfer of the digital macropixel value n to the system—4. A-D conversion of the analog macropixel signal value n—5. Pulsing of the external macropixel value n and buffering of the digital macropixel value n

through 3 are not pulsed (2). Then the measurement field limit for sensor 0 is reached.

In the third section, the signal value logging of the sensor begins. Figure 13 shows the pulse pattern for blanking signal value logging (QDWA) and signal value logging (QSWA), for macropixel generation (QSUM), for triggering the A-D converter (QADC), and for triggering a digital external data buffer (QLDD).

After completion of the data logging for sensor 0, job sequencing moves on to the fine adjustment of sensor 1 (4) and then to data logging of sensor 1 (5). Because according to the task definition, no data from sensor 1 are to be logged, the CLIC runs through sections (4) and (5) in an extremely short time. Sensor 1 is pulsed but with no data logging initiated by the CLIC.

In the connection with (5), the fine adjustment of sensor 2 by five individual pixels (6) begins. The following sections (6), (7), (8), and (9) now run analogously to sections (2) and (3).

Figure 14 shows the signal activity of the CLIC during the transfer of data of the already digitized data to a central data logger corresponding to the application illustrated. The simple programmability of the CLIC assumes special significance for quick adaptation to modified measurement or evaluation conditions.

In a modification of the above example, with the same measurement setup only macropixels 4 through 7 defined in the measurement field of each sensor are to be

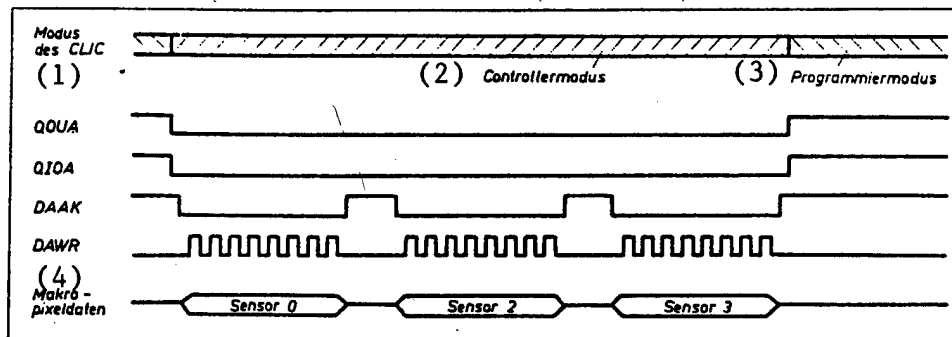

Figure 14. Output Signal Activity of the CLIC for Data Transfer Corresponding to the Application

Key: 1. CLIC mode—2. Controller mode—3. Programming mode—4. Macropixel data

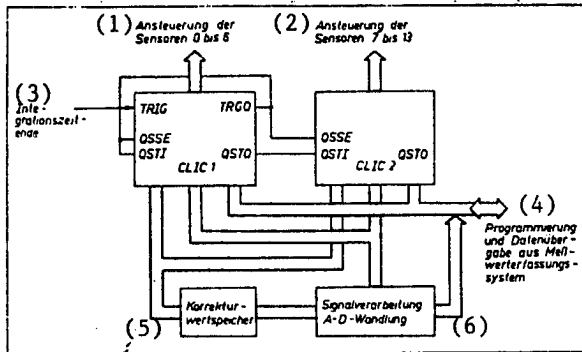

Figure 15. Example of Cascading

Key: 1. Control of sensors 0 through 6—2. Control of sensors 7 through 13—3. End of integration interval—4. Programming and data transfer from data logging system—5. Correction storage—6. Signal processing, A-D conversion

logged. This occurs because the values of the CLIC-internal registers for the common offset and the number of macropixels per sensor are reprogrammed as follows:

Macropixels per sensor = 4 Common offset = 17

All other registers remain unchanged. Thus, adaptation to these new evaluation conditions is complete.

For the evaluation of layouts with more than seven CCD line sensors, it is possible to cascade several CLIC's. Figure 15 shows how two CLIC's are connected to control a focal plane with 13 CCD line sensors (see also Figure 1). By linking identical connectors of the CLIC's it is possible for both circuits to pulse the same signal processing and to access a common memory block. Using the cascade chain, it is possible to always guarantee both with the hardware and with the support of the programming of the internal registers that only one CLIC is using shared buses.

If a specific CLIC must be addressed, this selection takes place via its QSSE connector.

Summary

Using the CLIC ASIC, compact and flexible data logging systems with low power consumption can be produced. After appropriate initialization, the circuit autonomously controls the entire signal acquisition process. All types of CCD line sensors produced in the GDR can be controlled directly with the use of the driver. Without the assistance of Dr. Schmidt (Carl Zeiss Jena), the development time of only 3.5 months would have been impossible. The programs CLICmod, PATPRI, and LABCON as well as the carrier plate for 124-pin QFP housings can be purchased.

Additional information can be obtained from the Academy of Sciences of the GDR Institute for Space Research Office for Patent Law and Licenses (BfSL) Rudower Chaussee 5 Berlin, 1199.

Bibliography

1. Schwarzer, H., Hoffmeister, A., "Spectrometer for Multispectral Image Analysis," WP GO1 J292134/5.
2. Korsitzky, H., Zimmermann, G., "Process for Evaluation of Signals of Optoelectronic Sensors, Particularly of Sensors in Multichannel Image Recording Systems With Different Signal Levels for Each Channel," WP H04N/ 321792.5.
3. Benning, K., Buerger, B., "Application Specific Integrated Circuits," (Continuing series), beginning in RADIO FERNSEHEN ELEKTRONIK, Berlin, Vol 38 No 1, 1989, pp 27-30.
4. Korsitzky, H., Foerste [sic], Th., "CLIC Manual," Berlin, Institute for Space Research, 1989.
5. "Unload card system 160 (Reg. no. 744/87)," Research Center for Machine Tool Engineering Karl Marx Stadt.
6. Norden, J., Neidhardt, M., "Program Description LABCON," Berlin, Institute for Space Research, 1989.
7. Foerste [sic], Th., "Programming Manual CLICmod," Berlin, Institute for Space Research, 1988.
8. Fechner, G., "User Description PATPRI," Berlin, Institute for Space Research, 1988/89.

U5301 FC-301

90WS0102B East Berlin RADIO FERNSEHEN ELEKTRONIK in German Aug 90 pp 491-493

[Article by Dipl.-Eng. Frank Seiler and Dipl.-Eng. Achim Seider: "Gate-Array Circuit U5301 FC-301; first paragraph is RADIO FERNSEHEN ELEKTRONIK introduction]

[Text] The gate-array circuit U5301 FC-301 permits connection of two incremental path or angle calculation systems to a microcomputer. The IC is provided for connection to both 8- and 16-bit processors.

The U5301 FC-301 ASIC was created within the framework of the development of a universal control computer for digital positioning systems with direct current motors. With this assembly, using different software it is possible to produce the following controller structures:

- two independent digital rotational speed regulators with measurement systems on the axles of the motors
- two independent digital position regulators with cascaded rotational speed regulators and measurement systems on the axles of the motors
- a digital position or status regulator on a two-mass system with a load measurement system and cascaded rotational speed regulator and measurement system on the axle of the motor.

Compared to similar solutions in the gate-array system U5200, this ASIC has a higher maximum counting rate and improved coupling to single-chip microcomputers and 16-bit processors.

Function

The IC is intended to permit connection of two incremental path or angle calculation systems to a microcomputer. A directional discriminator generates forward or backward counting signals from the two input pulses which are offset by 90 degrees. This makes it possible to select single, dual, or quadruple pulse evaluation. The generation of the counting signals and their selection for channel A is shown in Table 1. The coding of channel B is analogous to it. The counting signals arrive for each measurement system channel at a 16-bit forward-backward counter to which in each case a 16-bit storage

register is connected downstream, where, without interrupting the counting process, the counter contents can be written with a hardware or software strobe. Both counters can be cascaded by an external signal to a 32-bit counter which can then only be controlled by the inputs of channel A. The circuit is provided for connection to both 8- and 16-bit processors. It can be read and written as static RAM and is programmed via an 8-bit command register. The IC has the following additional functions:

- Zeroing of the counter upon appearance of a zero pulse from the measurement system with hardware and software release
- External strobe with software release
- Monitoring for measurement system errors by checking non-equivalence at the counter inputs
- 8-bit status register to signal active zero pulses, strobe pulses, and measurement system errors
- Interrupt output for signaling zero pulses, external strobes, or measurement system errors.

Table 1: Pulse Edge Selection

F2A	F4A	ZA1	ZA2	Counting pulse
Single evaluation				
L	x	H-L	H	Forward pulse
L	x	L-H	H	Backward pulse
Dual evaluation				
H	L	H-L	H	Forward pulse
H	L	L-H	L	Forward pulse
H	L	H-L	L	Backward pulse
H	L	L-H	H	Backward pulse
Quadruple evaluation				
H	H	H-L	H	Forward pulse
H	H	L	H-L	Forward pulse
H	H	L-H	L	Forward pulse
H	H	H	L-H	Forward pulse
H	H	H	H-L	Backward pulse
H	H	H-L	L	Backward pulse
H	H	L	L-H	Backward pulse
H	H	L-H	H	Backward pulse

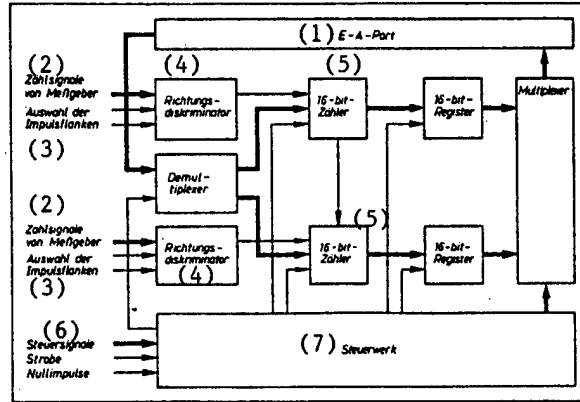

Figure 1. Schematic

Key: 1. I/O Port—2. Counting signal from sensor—3. Pulse edge selection—4. Direction discriminator—5. 16-bit counter—6. Control signals, Strobe, Zero pulse—7. Control unit

Figure 1 presents the block diagram of the ASIC U5301 FC-301. Counter and register addressing follows Table 2.

With the 8-bit-wide command register, the following functions can be invoked:

- Bit 0 = H: Clear counter A upon appearance of a zero pulse on channel A (in the 32-bit mode, counter B is also cleared)
- Bit 1 = H: Clear counter B upon appearance of a zero impulse on channel B (cannot be activated in the 32-bit mode)
- Bit 2 = H: Acceptance of the contents of counter A into memory A if an external strobe pulse is present on channel A. (in the 32-bit mode, counter B is also accepted in memory B)
- Bit 3 = H: Acceptance of the contents of counter B into memory B if an external strobe pulse is present on channel B (cannot be activated in the 32-bit mode)
- Bit 4 = H: Interrupt release with measurement system error on channel A or B
- Bit 5 = H: Interrupt release with zero pulse or external strobe on channel A or B
- Bit 6 = H: Stop counter A (deactivation of counting input)
- Bit 7 = H: Stop counter B (deactivation of counting input)

Table 2: Register and Counter Addressing

/OE	/CE	A2	A1	A0	/WR = H (Read)	/WR = L (Write)
L	L	L	L	L	Reset status byte	Set command byte
L	L	L	L	H	Strobe counter A, read status	Set L byte, counter A via D0 through D7
L	L	L	H	L	Read memory A (16-bit)	Set counter A (16-bit)
L	L	L	H	H	Read memory A, H-section via D0 through D7	Set L byte, counter B via D0 through D7
L	L	H	L	L	Strobe counter A and B, read status byte	Set counter B (16-bit)
L	L	H	L	H	Strobe counter B, read status byte	Set H byte, counter A via D0 through D7
L	L	H	H	L	Read memory B (16-bit)	Set H byte, counter B via D0 through D7
L	L	H	H	H	Read memory B, H-section via D0 through D7	—
L	H	X	X	X	—	—
H	L	L	L	L	—	Set command byte
H	L	L	L	H	—	Set L byte, counter A via D0 through D7
H	L	L	H	L	—	Set counter A (16-bit)
H	L	L	H	H	—	Set L byte, counter B via D0 through D7
H	L	H	L	L	—	Set counter B (16-bit)
H	L	H	L	H	—	Set H byte, counter A via D0 through D7
H	L	H	H	L	—	Set H byte, counter B via D0 through D7

Table 2: Register and Counter Addressing (Continued)

/OE	/CE	A2	A1	A0	/WR = H	/WR = L
H	L	H	H	H	—	—
H	H	X	X	X	—	—

With the signal /RES, 00H is written in the command register. An 8-bit status register informs the computer of the following events:

- Bit 0 = H: Zero pulse on channel A
- Bit 1 = H: Zero pulse on channel B
- Bit 2 = H: Strobe pulse on channel A
- Bit 3 = H: Strobe pulse on channel B
- Bit 4 = H: Measurement system error on channel A (ZA1 = /ZA1 or ZA2 = /ZA2 or NA = /NA)
- Bit 5 = H: Measurement system error on channel B (ZB1 = /ZB1 or ZB2 = /ZB2 or NB = /NB)
- Bit 6 = H: IC operating in 32-bit mode

Table 3: Pin Identification

Input and Output	Identification	Comments
S	GND	Ground
S	VCC	Operating voltage
I (LHT)	CA	Timing pulse input A
I (LHT)	CB	Timing pulse input B, set to L
I (LHT)	MT	Input for mode control signal
I (LHT)	QI	Input of the LSSD shift chain
O	QO	Output of the LSSD shift chain
I (LHT)	S1	Interface control signal 1
I (LHT)	S0/TI	Interface control signal 0/ Test structure input
O	TO	Test structure output
O	CLO	Negator 2 output
I	XTAL2	Negator 2 input
O	ZP	Negator 1 output
I	XTAL1	Negator 1 input
I	/RES	Reset
I	/CE	Activate circuit
I	/OE	Activate data outputs
I	A0	Address
I	A1	Address
I	A2	Address
I	/WR	Write via data inputs
OD	/INT	Interrupt signal output
BD	DO - D15	Bidirectional tri-state data bus for connection to 8- or 16-bit microprocessors
I	/STA	Strobe for counter A

I	/STB	Strobe for counter B
I (HHT)	ONA	Connection for nonequivalence monitoring (NZA1, NZA2, and NNA are not evaluated)
I (HHT)	ONB	Connection for nonequivalence monitoring (NZB1, NZB2, and NNB are not evaluated)
I (HHT)	/KAS	Counter cascading
I (HHT)	F2A	Pulse edge evaluation channel A
I (HHT)	F4A	Pulse edge evaluation channel A
I (HHT)	F2B	Pulse edge evaluation channel B
I (HHT)	F4B	Pulse edge evaluation channel B
I	/NFA	Release of the zero pulse for counter A
I	/NFB	Release of the zero pulse for counter B
I	ZA1	Input pulse for counter A
I	/ZA1	Negated signal to ZA1
I	ZA2	Input pulse for counter A, 90-degree phase shift from ZA1
I	/ZA2	Negated signal to ZA2
I	ZB1	Input pulse for counter B
I	/ZB1	Negated signal to ZB1
I	ZB2	Input pulse for counter B, 90-degree phase shift from ZB1
I	/ZB2	Negated signal to ZB2
I	NA	Input for digital zero pulse signal from measurement system (channel A)
I	/NA	Negated signal to NA
I	NB	Input for digital zero pulse signal from measurement system (channel B)
I	/NB	Negated signal to NB
O	VA	Forward counter pulse (channel A)
O	RA	Backward counter pulse (channel A)
O	VB	Forward counter pulse (channel B)
O	RB	Backward counter pulse (channel B)
O	NIA	Zero pulse output from counter A
O	NIB	Zero pulse output from counter B

Measurement system errors are only signaled when ONA or ONB = L. Bit 0 through Bit 5 stay at H until reset by reading the address A0 = A1 = A2 = L. The interrupt output is also reset at the same time.

Inputs and Outputs

Table 3 shows the allocation of all pins of the U5301 FC-301; Figure 2 contains the connector allocation. The

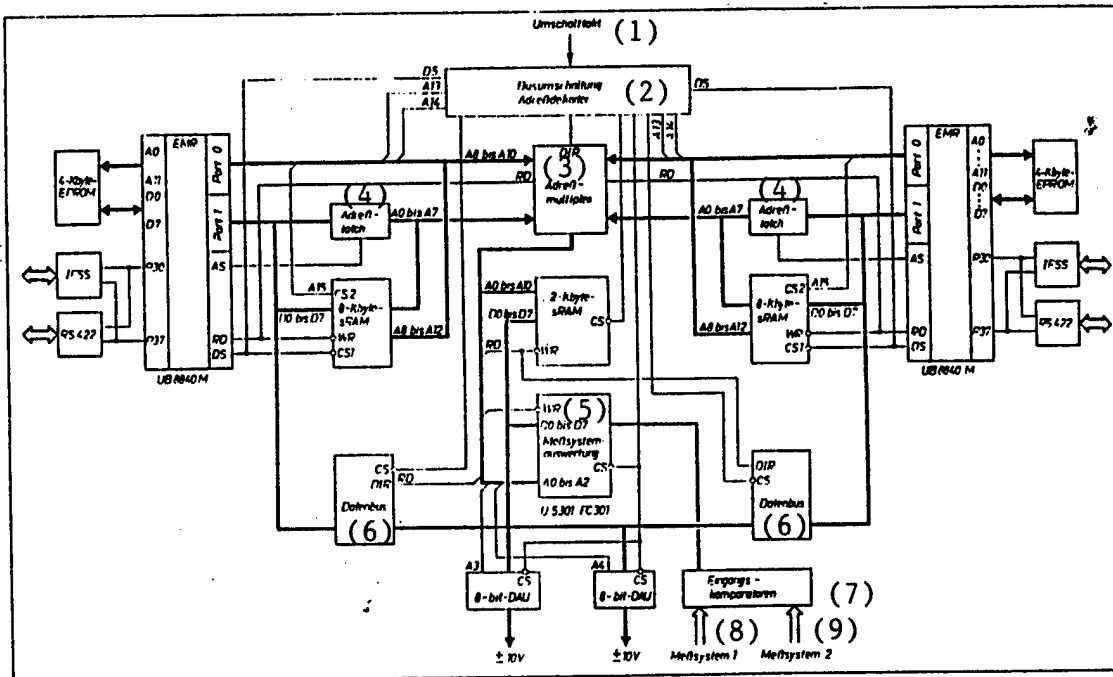

Figure 3. Sample Application

Key: 1. Shift pulse—2. Bus switching address coder—3. Address multiplexer—4. Address latch—5. Measurement system evaluation—6. Data bus—7. Input comparator—8. Measurement system 1—9. Measurement system 2

abbreviations in the Input and Output column represent the following: I = input, O = output, LHT = input stage with L-holding transistor, HHT = input stage with H-holding transistor, BD = bidirectional stage, OD = open-drain output stage, S = power supply.

The time conditions are such that the pulse interval of the counter channels in the quadruple evaluation must be $> 1/f + 30$ ns; the limit frequency f of the system timing pulse is 20 MHz.

Sample Application

The drive computer operates with two single-chip UB 8840 microcomputers which are coupled by a two gate bus. Connected to the bus are a 2-Kbyte RAM for data exchange, two 8-bit D-A converters for outputting the correcting variables to the current regulated power stages, and a biaxial interface to receive the actual values from incremental path or angle sensors with counter pulses 90-degrees out of phase. The coupling to host computers for transfer of the nominal values and status messages is a serial connection via IFSS or RS-422 drivers (Figure 3).

Germany: Circuit Pattern Drafting Machine Described
90WS0082A East Berlin FEINGERAETETECHNIK
in German Jun 90 pp 252-254

[Article by Dr.-Eng. H. H. Finck, VEB Data Processing Center Rostock: "Circuit Pattern Drafting Machine"]

[Text] The drafting process for modern circuit boards is no longer conceivable without extensive computer support. During layout development, digitized circuit board pattern data are generated. Based on these data, as the process continues, control drawings of the circuit patterns and phototemplates for circuit board fabrication must be produced many times as quickly as possible. For this, efficient and cost-effective drafting machines capable of processing the digital pattern data are required. However, the required drafting technology is not yet available to the extent needed.

For this reason, a suitable circuit pattern drafting machine (LBZM) was cooperatively developed in recent years by the Engineering University for Ocean Navigation Warnemuende/Wustrow, the Development and Production Office for Microelectronic Rationalization Means in the VEB Data Processing Center Rostock, the VEB Microelectronics Stahnsdorf, and other companies.¹ The machine enables both the preparation of paper drawings and films of the circuit board patterns. To date, 35 machines of this type have been produced. Following evaluation of production and user experience, the machine was reworked and now bears the name LBZM II. Production of this machine began in the second half of 1989.

1. Structure

The machine consists of a basic equipment rack and a lower equipment cabinet rack (Figure 1). In the lower

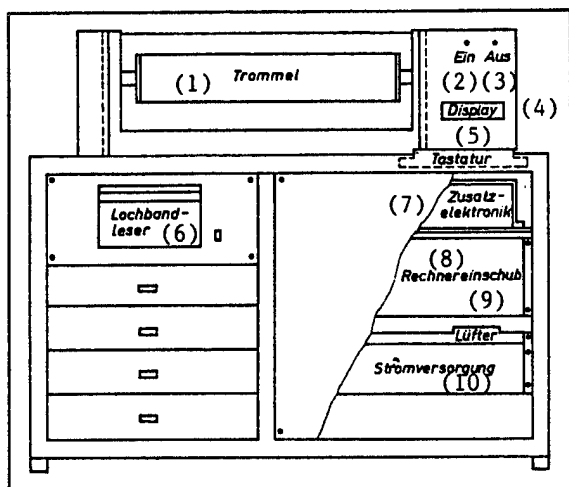

Figure 1. Structure of the Circuit Pattern Drafting Machine
Key: —1. Drum—2. Input—3. Output—4. Display—5. Keyboard—6. Punched tape reader—7. Additional electronics—8. Computer module—9. Fan—10. Power supply

cabinet are located all electronic assemblies (including punched tape reader and keyboard) as well as the power supply. The basic machine is mounted on top of the lower section. It consists of a cast aluminum housing and the following assemblies: drum, roller worm drive, incremental positioner, and drafting head with its guide.

2. Operating Principle

The LBZM is a raster drafting machine with a rotating drum and a stepped controlled drafting mechanism parallel to the axis of the drum. The drafting head directs a modulated beam of light perpendicular to the drum. Instead of exposing a film, it is also possible to produce a paper drawing on special paper by a by means of electric discharge machining (EDM).

The circuit pattern is created continuously column by column from (partially) overlapping micropixels (0.05mm x 0.05mm).

During data acceptance by the machine, the pattern data which are present in vectorial form are stored in the main memory partially presorted. Special pattern structure programs check all stored pattern elements to determine whether they contain pixels which appear in the current column (y-coordinate, drum circumference) of the pattern to be drawn (Figure 3). If such a pattern element is found, the microcomputer uses a plotted vector-raster conversion to calculate the raster points necessary to represent the pattern element in this column.² This pattern layout necessary for the pixel by pixel exposure progresses continuously in the x-direction.

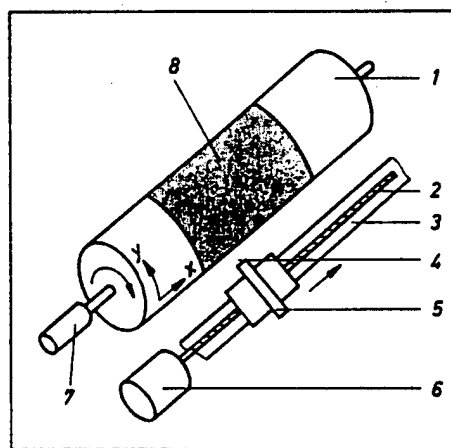

Figure 3. Operating Principle

Key:—1. Drum—2. rolling worm drive—3. optical drive—4. Light beam—5. LED drafting head—6. Stepper motor—7. Incremental shaft encoder—8. Film

The pixels thus calculated are stored in a special column memory which is read out after filling, synchronized with the rotation of the drum by an incremental shaft encoder. The contents of the memory control the external automatic exposure mechanism. After one memory column (0.05 mm) has run, the next one is read out. The continuous rotation of the drum corresponds to the y-movement. The stepped column progression (x-movement) is controlled by the functional group of the stepper motor/rolling worm drive. While the pattern memory is read out, the microcomputer generates the pattern for the next 8 columns in a second column memory. When the contents of the first memory are depleted, the computer switches to the pattern memory which was filled in the meantime. The overall pattern results from the sequence of the column patterns. Because of the stepped layout of the raster pattern, only a relatively small pattern memory of 8 Kbytes is required. Along with the pattern layout algorithms of the vector-raster conversion, the principle of simultaneous filling and reading out of the two switchable pattern memories contributes significantly to the machine's short plotting times.

3. Mechanics

3.1 Basic Machine

The basic equipment rack represents the most mechanically demanding part of the LBZM. It is here that the functional groups crucial to the accuracy of the machine are located. The drum has a diameter of 127.1 mm. Adding twice the thickness of the film (0.1155 mm) yields an effective drum diameter of 127.3 mm. 7,200 pixels in the y-direction generate the pattern. The usable pattern area with a drum length of 500 mm is 360mm x 500 mm. The remaining 40 mm of film is used to mount the film.

The drum is driven by a single-phase AC motor via V-belts. Drum rotation is synchronized by an incremental angle transmitter IGR2000. A PLL pulse quadrupling gives the resolution required for a pixel size of 0.05 mm. The rotational speed of the drum is approximately 670 rpm. This yields a pixel sequence frequency of 90 kHz. The spindle (diameter 25 mm) is driven by an IPS5 incremental positioner with a toothed belt drive. It is located in an optical guide device and effects a software-controlled, stepped travel of the drafting head in steps of 0.05 mm in the x-direction.

3.2 Flash-Unit Attachment

The light emitting diode used for exposing the film is located in a flash-unit attachment (LBE).³ The LBE is a compact assembly (Figure 4) weighing approximately 70 g.

The light emitting diode emits red light of wavelength

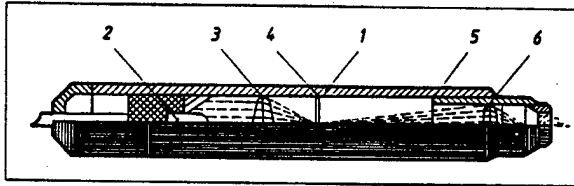

Figure 4. Flash-Unit Attachment

Key: —1. Tube casing—2. Diode cell—3. Converging lens—4. Special diaphragm—5. Annular diaphragm—6. Focusing lens

665 nm. The switching frequency of the light spots depends on the exposure time required. With the LBZM, taking the pixel sequence frequency of 90 kHz into account, exposure times of 11 μ s are possible. With a switch, fine adjustments of exposure times of 0.2 to 8 μ s can be obtained. Thus, the user can adjust the exposure parameter for differing film sensitivities, which can change from lot to lot. Good results were obtained with exposure times of 3.2 μ s.

4. Hardware

The electronics of the LBZM can be subdivided into the complex computer, power supply, LED and stylus control system, and peripherals:

- The computer component, controlled by a U880 processor, consists of four standard and six custom assemblies with K 1520 format with an appropriate bus connection. The punched tape reader, keyboard, and display are connected via the standard assemblies. The custom assemblies implement the switchable pattern memory, the stepper motor drive, the automatic exposure mechanism, and the connection of all machine signals. In addition to the pattern memory, there is a 48 K main memory. The resident software is on a U2732 EPROM.
- A 5 V/10 A switching power pack and an additional 12 V/3 A; -5 V/0.5 A module are used for the power

supply. A 24-V power pack supplies the stepper motor. Switch functions for specific parts of the machine are controlled via a switching module also located in the power supply module.

- Control of the LED and the paper pick-up, stylus are handled respectively by electronics units. A specially developed high voltage generator (500 V) is used for stylus drive system. The current pulses of 90 to 120 mA required for control of the LED are supplied by the LED control.
- Peripherals—A keyboard and a 16-character alphanumeric display are used for man-machine communication. Both have been integrated into the machine. The display is implemented via four 10-element VQC's. Data input via punched tape is possible. Standard serial interfaces (IfSS or V.24) are provided to connect the machine to modern device technology for data transfer.

5. Software

The operational software of the LBZM controls the processing cycle of the entire machine, data transfer and processing, pattern layout, and man-machine communication. The software also includes test routines to check the machine's functions.

After the machine is turned on, a bootstrap handles basic initialization and relocation of software and transfers control to the monitor program.

Because the machine can be operated in various modes, the operational software is generated by overlay procedures depending on the mode specified by the operator. A preferred mode is defined as a default. The circuit pattern drafting machine has the following characteristics:

- -I/O medium: Punched tape or serial data communication (V.24 or IfSS)
- Data format: Following INT-digitizing guideline S-622 (only small amounts) or internal data structure
- Lands: Round, octagonal, square, or round with a centering hole
- Conductor tracks in all angular orientations
- Positive or negative representation
- Processing of large amounts of data
- Operator guidance
- Self testing and fault diagnosis
- Test monitor.

A few special data manipulations are possible based on the INT digitization code:

- Rotating a circuit board
- Mirroring a circuit board
- Mirroring text
- Scale selection 1:1 or 1:2
- Drawing solder masks.

If the thoroughly documented LBZM internal data structure is used directly as the input data format, all data

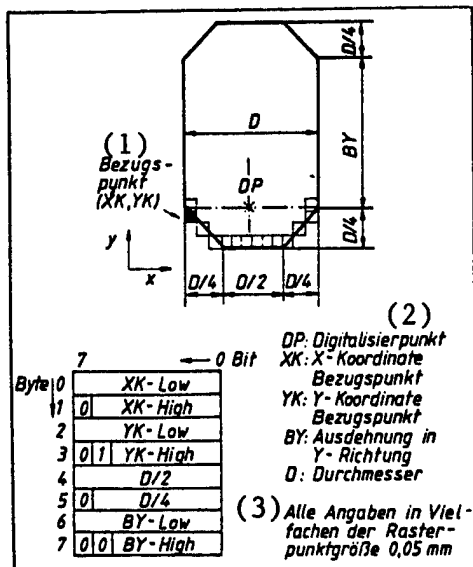

Figure 5. Internal Data Structure of an LBZM Data Block (Perpendicular conductor track)

Key: —1. Reference point—2. DP: Digitizing point, XK: X-coordinate reference point, YK: Y-coordinate reference point, BY: Length in Y-direction, D: Diameter—3. All data in multiples of raster point size 0.05 mm

manipulations must already be performed when the data block is created. This data structure even permits representation of circular elements.⁴ Figure 4 contains an example of the machine-specific data structure. The lowest valued x-raster point serves as the reference point for each pattern element based on the pattern layout continuing in the x-direction. As the pattern layout in Figure 5 shows, the conductor track ties are implemented as octagons. Thus, optimum conductor track ties are obtained.

Each pattern element requires an 8-byte data block. Two consecutive data blocks are required for representation of circular elements.

As a standard, up to 5,000 pattern elements such as rectangles, octagons, lines, circular elements, and symbols can be processed in the data memory (40 K). When this memory capacity is exceeded, the entire pattern can be composed by overlaying partial patterns.

First the partial pattern of the accepted data is drawn. After the drawing is finished, the drafting head is automatically repositioned and additional data accepted.

6. Applicational Considerations

The machine is very fast. Only approximately 5 to 8 min. is required for preparation of a pattern 170 mm x 215 mm.

Test films were evaluated to determine drawing accuracy. In both the x- and y-directions, land deviations of only +/-0.03 mm could be detected for the entire circuit

pattern. Tolerances are thus less than the size of one pixel. The quality of the drawings permits fabrication through hole plated circuit boards. In the future a major area of application of the LBZM will consist of a serial coupling of the circuit pattern drafting machine with high performance computers. Circuit pattern drafting systems available on such computers will support all drafting processes and data manipulations. Currently, coupling with the CADy circuit board design system has been achieved. The conversion of CADy pattern data into LBZM format, essential before execution of a drawing, is performed by a special conversion program which utilizes all the representational potentials of the machine.

Work is also in progress to connect the machine to the BESSY assembly design system.⁵

Table 1. LBZM II Technical Specifications

Pixel size	0.05 mm x 0.05 mm
Working area	360 mm x 500 mm
Plotting time	5 to 7 min for a circuit pattern 215 mm x 170 mm
Drum rotation speed	670 rpm
Pixel sequence frequency	90 KHz
Film	ORWO FP 6
Accuracy	Deviations smaller than a pixel (when climate requirements of film are met)
Processor	U880 D
Power supply	220 V/50 Hz; approx. 400 V A
Weight	Approx. 200 kg
Dimensions	1100 mm x 600 mm x 1200 mm

Bibliography

1. Mennenga, H.; Brott, R.G.; Lantow, H.; Reatzke, J.; "Circuit Pattern Drafting Machine," RADIO FERNSEHEN ELEKTRONIK, [East] Berlin, Vol 6 1985, pp 379-381.
2. Reatzke, J., "On Raster Representation of Technical Drawings, Especially Circuit Patterns, Under Special Consideration of Vector-Raster Conversion," Dissertation A. 1986. Engineering University for Ocean Navigation Warnemuende/Wustrow.
3. Kralitschek, B., "Flashing Mechanism With LED for a Circuit Pattern Drafting Machine," FOTOGRAFIE, Vol 2, 1990, pp 77-78.
4. Circuit Pattern Drafting Machine Documentation, VEB Data Processing Center Rostock, Department EPMR.
5. Mennenga, H., "BESSY Design for a Printed Circuit Broad CAD System," FEINGERAETETECHNIK, [East] Berlin, Vol 37 No 8, 1988, pp 348-350.

UK: Organic Semiconductors Developed

91AN0033 Rijswijk POLYTECHNISCH
TIJDSCHRIFT in Dutch Oct 90 p 6

[Article: "Organic Semiconductors Turn Out To Be Superfast"]

[Text] Strange as it may seem, the Cavendish Laboratory at the University of Cambridge is presently testing semiconductor components by means of a laser system. Nothing special, one would say, were it not for the fact that the semiconductors are manufactured from organic materials.

Although the polymer-based components have a relatively large circumference, they are only a few hundred molecules thick.

Dr. Richard Friend, director of the Femtosecond Laser Group which is responsible for this research, is convinced that the present results should make it possible to manufacture a transistor hardly the size of a molecule by the turn of the century.

It has been discovered that the organic materials studied change color whenever they are excited by a laser beam. A second laser beam then measures the degree of color change in the tested material. Such nonlinear processes could also be used in optical computers, making them a million times faster than present supercomputers.

In the mean time, a transistor consisting entirely of polymer-polyacetylene has already been successfully designed. Recent research has shown that certain other organic materials are also perfectly suitable for such applications.

The new "plastic" chips have properties for which conventional silicon versions are no match, and they are expected to mark a new era of even greater miniaturization. Scientists from the laboratory are already anticipating that the optoelectronic effects which have been generated using this process will have a widespread and strong impact. Possible applications include fiber-optic communications, optical data processing, and interconnections between computers and optical transmission equipment.

Only optical measuring systems making use of laser beams are fast enough to measure and record these changes.

UK: Sinclair Designs Fast Parallel Chip

91AN0058 Brussels INDUSTRIE in Dutch Sep 90 p 28

[Text] The British manufacturer Sinclair will soon introduce a new parallel data processing chip to the market: the Hyper-RISC [reduced instruction set computer]. The new chip has a processing speed of 200 Mips [million instructions per second] and emulates all existing chips, including the latest from Intel and Motorola. Characteristics of the Hyper-RISC are the transputer-like gates,

which allow the parallel operation of any number of chips. This 32-bit processor has an access time of 3 to 4 nanoseconds and is, according to Sinclair, faster than all of its predecessors. In addition, several functions have been integrated on the chip itself: read-only memory (ROM), random-access memory (RAM), video drive, input and output circuits. The chip manages its own memory. It addresses external memories in page mode, which makes it possible to consult various databases via the mere 32 pins. There is no limit to Hyper-RISC's total memory.

The instructions are only 8 bits long and are processed on-line by the chip. This allows high-speed processing. There is also a super fast on-chip ROM for subroutines in which macros can be stored. It is this on-chip ROM that makes the Hyper-RISC competitive with all other chips; another striking characteristic is its self-timing function. While interacting with the outside world, the chip works with clock pulses, but internally it operates at maximum clock speed. Normally, all internal pulses are synchronized with the slowest gate, but this is not the case with the Hyper-RISC.

The chip is based on a low-energy bipolar process from Plessey Semiconductors of Manchester, the collector diffusion isolation (CDI) technology. Hyper-RISC does not implement complementary metal-oxide semiconductors (CMOS), because their power consumption is too high.

SCIENCE & TECHNOLOGY POLICY

EUREKA Assessment Panel Established

90AN0385 Amsterdam COMPUTABLE in Dutch
6 Jul 90 p 15

[Article by COMPUTABLE correspondent: "Dekker Thinks EUREKA Is a Success"]

[Excerpts] The Hague—Despite the criticism and skepticism it faced during the initial period, the EUREKA [European Research Coordinating Agency] project for industrial research is gradually becoming a success. This technology program has firmly established itself as a stronghold of European scientific and technological cooperation.

This is what Prof. W. Dekker, chairman of the board of Philips, declared last Tuesday at the installation of the EUREKA Assessment Panel. This panel has seven members and is headed by Prof. Dekker. It was installed by Minister J. Andriessen (Economic Affairs), who will preside over EUREKA until the end of the year. The decision to set up an assessment was made during the EUREKA Ministerial Conference in Rome. This was done at the proposal of the Dutch delegation.

The panel will assess the progress made by EUREKA from different angles. A report on the issue must follow before the end of this year. The Advisory Board for

Scientific Research Policy (RAWB) had urged Minister Andriessen to conduct a critical evaluation of the EUREKA program. The RAWB is under the impression that the present approach of EUREKA results in excessive disintegration. According to the RAWB, EUREKA threatens to slip away into an imbroglio of projects, all very divergent in size and orientation. [passage omitted]

Talking about the assessment itself, Dekker said that many research and development projects take a long time in producing results. Eventually, the market is the best criterion for a project's success. Thus Dekker recommended resisting the temptation to "remove the plant from the pot too often to see whether the roots are actually growing." It is still premature to assess the results of the individual EUREKA projects.

If necessary, improvements can still be made. "EUREKA is definitely under way; its destination is known but the question is whether the best route has been taken. That is what the panel will have to examine," said Dekker.

Minister Andriessen declared that special attention will be paid to achieve EUREKA's main goal, which is to strengthen the productivity and competitiveness of European industry and of the national economies on the world market.

Evaluation of EUREKA Planned

90AN0379 Amsterdam COMPUTABLE in Dutch
8 Jun 90 p 1

[Article by COMPUTABLE correspondent: "EUREKA Presidency in Dutch Hands: Enough Projects, But Quality Is Questioned"]

[Text] Rome—At the annual EUREKA [European Research Coordinating Agency] conference held in Rome at the end of last week, 21 initiatives for new high-tech projects were approved. The overall cost of these projects is estimated at roughly 3.5 billion Dutch guilders. Dutch companies, institutions, as well as universities are participating in 15 of these new projects. The Netherlands will assume the presidency of EUREKA from 1 June this year until May 1991. At the conference in Rome, Minister of Economic Affairs J. Andriessen took over the chairmanship from the Italian Minister of Scientific Research, A. Ruberti.

Seven of the approved projects involving Dutch participants were already in progress, but were not granted official EUREKA status until now. This brings the number of projects involving Dutch participation to 89, while the total number of EUREKA projects amounts to 400, with an overall project value of about 19 billion guilders (exclusive of JESSI).

The main technological areas covered by EUREKA are robotics and production technology, information technology, and biotechnology.

One major project approved, ECRAS, focuses on the simplification and automation of the production of composite parts. Fokker is involved in this project, which comes under Europari, a general name for projects related to the aviation industry. Part of the EUREKA funds have also been allocated to Europari-EIFAS, a project that seeks to automate components assembly. Fokker is participating in this project, as well.

EUROMAR-ATOMAR is a vast project in which several countries are taking part. Its goal is to implement computers to calculate the amount of damage caused by air pollution on the sea in and around Europe. The Rotterdam-based company Geosens, as well as the Tidal Waters Department of the Ministry of Transportation and Public Works are participating in ATOMAR on behalf of the Netherlands.

In the next few months, the EUREKA program will be submitted to a thorough evaluation. An international committee headed by Philips' former chief executive W. Dekker must assess the more than 300 projects presently under way and file a report on the issue by the end of the current year. This Dekker Committee should find out whether the EUREKA program has contributed sufficiently to strengthening Europe's industrial position.

The day before the EUREKA conference started, the Advisory Board for Scientific Research Policy (RAWB) had called for such an evaluation. The RAWB openly questioned this cooperative program, which has been under way since 1985. It is feared that this initiative is doomed to languish slowly unless prompt action is taken. More specifically, the board has doubts about the quality of several projects. Although the number of projects submitted and approved may be sufficient, their European applicability is often questionable. The RAWB suggests the possibility that EUREKA become more selective, concentrating its efforts on projects with a distinct European flavor.

Minister Andriessen was therefore sent to Rome with the clear message that the program needed to be remodeled. In fact, the Minister of Economic Affairs partly agreed with the RAWB by admitting that "there is no wheat without chaff." In recent years, certain projects slipped through which, with hindsight, did not meet the standards at all. But Andriessen does not believe, as does the RAWB, that the initiative will slowly decay for lack of coordination and sufficient control on how the money is spent.

During the ministerial EUREKA conference, the minister therefore emphasized the importance of continuing this research program. As an example of spheres of interest in which joint efforts can yield results, he referred to strategic projects such as that on high-definition television (HDTV), the Joint European Sub-micron Silicon Initiative (JESSI), the Corporation for OSI Networking in Europe (COSINE), and the Program for a European Traffic with Highest Efficiency and Unprecedented Safety (PROMETHEUS). Especially the

HDTV project and JESSI are relevant to the whole of Europe. Philips' and Thomson's intention to combine their forces in the field of HDTV entirely outside the scope of EUREKA, must, according to Andriessen, by no means be regarded as a threat to EUREKA.

Until recently, the membership of EUREKA was limited to the 12 EC countries as well as to some of the European Free Trade Association (EFTA) countries and Turkey. In addition, some Eastern European countries are involved in specific subfields, for instance in environmental projects.

Improved Links Between FRG, GDR Researchers Planned

90MI0347X East Berlin DFN MITTEILUNGEN
in German No 21, Jun 90 pp 7-8

[Article by Engineer Hans-Martin Adler, GDR Academy of Sciences, Institute of Computer Science and Engineering, Berlin: "DFN Services for GDR Scientists"]

[Excerpt] Cooperation among scientific organizations is currently considerably restricted by the absence of a telecommunications infrastructure in the GDR. Although the individual research centers maintain data bases, for example, covering various specialized areas, only scientists working in the immediate vicinity of the research institute concerned generally have access to the data stored in them. Cooperation between geographically distant institutes working on the same scientific discipline is time consuming and often complicated owing to the lack of telecommunications facilities. The effects on international cooperation are particularly serious.

Unlike their colleagues in Western countries, scientists in the GDR hardly ever have rapid access at present to data bases open to the public. Nor can they join yet in the exchange of ideas that has meanwhile become standard practice in scientific cooperation via electronic communications systems (electronic mail, message handling systems). This entails considerable disadvantages for teaching and research in the GDR. Participation in international experiments—such as in high-energy physics—is hardly possible without data communications operating within the international group. Point-to-point connections exist between individual institutes using lines rented from the German Post Office (DP) in the GDR.

Access to the national data banks is organized via the DP's hand-switched data network (HDN). Access to data banks in the CEMA countries works in the same way via a PAD [packet assembler/disassembler] to an X.25-junction node in Moscow.

Locally, experience has been acquired in the use of local area networks (LAN's) in training and office automation. Research and development work on LAN's for GDR PC technology is under way, especially in the universities.

The setting up of a public packet-switching network was to have overcome this state of affairs from mid-1990. Of the total of 4,000 terminals scheduled, 115 had been planned for Academy of Sciences (40) and university and technical college (75) facilities.

As regards the Academy of Sciences, a central project management has prepared for the establishment of a research network for the Academy that should allow its scientists to take part in long-range joint projects at the national level. The Academy of Sciences' Institute of Computer Science and Engineering (IIR) at Berlin-Adlersdorf is responsible for coordinating this work. A similar network has been prepared for the university and technical college sector under the leadership of the Technical University of Dresden. The objective of the planning work was to create an open communication system along the lines of the OSI [open system interconnection] reference model.

Analyses of the performance required generated the following service requirements for the initial pilot projects:

- **Dialog** to provide access to national and international research data bases;
- **Mail Services** as a support facility for long-range joint projects;
- **File Transfer** to transfer large data bases, especially in the high-energy physics and geocosmonomy fields;
- **Remote Job Entry** for long-distance use of high-performance computer resources.

As early as November last year, GDR scientific institutes established direct contract with the DFN [FRG Research Network] Association. The goal was to use the association's experience to open up opportunities for GDR scientists as well to take part in long-distance joint projects, especially with their FRG colleagues. The initial result of these contacts was a proposal for a pilot project to make the DFN services available to GDR scientists.

Goals of the Project

The scientific potential of the partners in the project is centered in about 50 GDR Academy of Sciences facilities. They have about 25,000 employees at 29 universities and polytechnics with a scientific personnel of about 29,000 and about 100,000 students. Territorial centers in this respect are Berlin and its surrounding area including Buch, Zeuthen, and Potsdam, then Dresden and Rossendorf, Freiberg and Zittau, Leipzig, Halle, Jena, Merseburg, Karl-Marx-Stadt, Rostock, and Magdenburg.

The overall objectives of the project are as follows:

- Establishment of a communications infrastructure for the GDR's scientific institutions;
- Introduction and use of OSI-compatible services;

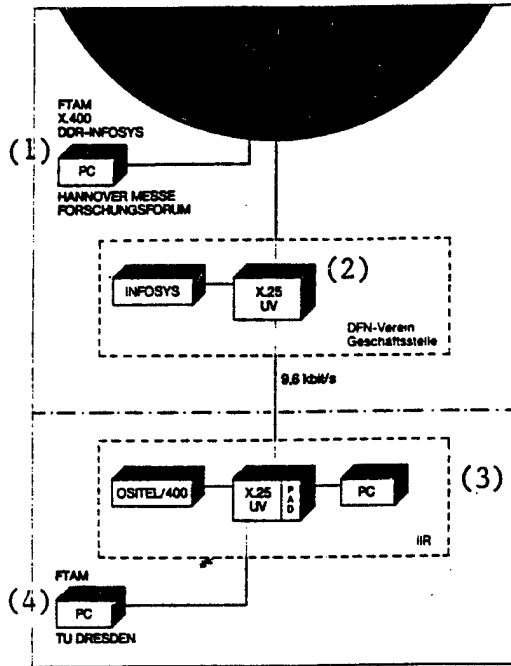

Fig. 1: Link between the Technical University of Dresden and the DFN Association via WIN

Key: 1. FTAM X.400 GDR INFO SYS PC Hanover Fair Research Forum —2. X.25 Switching Relay —3. DFN Association office —4. FTAM PC Technical University of Dresden

- Acquisition of experience in using the DFN services and an X.25 interface [Konnektivitaet];
- Formulation of example solutions for the application of communications services as reference solutions and a trial run in the use of public packet-switching networks.

In the short-term the lines to West Berlin rented by the IIR, the Humboldt University (HUB), and the Institute of High-Energy Physics (IFH) in Seuthen will be used as a basis for access to the DFN services for these establishments and the Technical University of Dresden, which has a link line to the IIR. The starting signal for this stage was given at the Research Forum at the Hanover Industrial Fair early in May 1990 with a demonstration of a GDR E-Mail based on OSITEL/400 at the IIR and on FTAM [file transfer access and management] between the Technical University of Dresden and the DFN Association's stand (Fig. 1)

In the medium-term basis, access by GDR scientific institutes to their cooperation partners in the FRG via WIN [wide integrated network] is the goal of a project proposed jointly by the DFN Association, the GDR Academy of Sciences, and the GDR universities and polytechnics with the support of the FRG Ministry of

Research and Technology (BMFT) and the GDR Ministry of Research and Technology (MFT).

This proposal envisages a linkup among the leading scientific regions in the GDR: Berlin, Dresden, Leipzig, Potsdam, Karl-Marx-Stadt, Jena, Magdenburg, Halle, and Rostock. The BMFT has set aside about 1.2 million Deutsche marks to create the infrastructure, while the MFT is providing 0.5 million marks, primarily for line costs, in 1990. The communications infrastructure will be set up in cooperation with the DP in view of its schedule for the provision of a public data network in the GDR.

In the long-term the pilot will create the conditions in which GDR scientific institutes may be linked up to the WIN. This goal is being pursued in close cooperation with the postal administrations of the two countries. This will create the prerequisites for rendering new communications technologies such as ISDN or high-speed networks accessible to the GDR as well and for its active participation in their configuration via its own research.

Pilot Project

The technical implementation of the pilot project is planned as follows (Figure 2):

- The linkup to the WIN via the DFN Association's office is made with a 64 kbit/s connection. The project proposal takes this into account.
- An X.25 switching relay is used for the transfer to the 9.6 kbit/s line to the IIR, the HUB, and the IFH.
- The switching relay will be designed to allow unilateral network management with access control and volume recording.
- Two communications servers will be connected to the switching relay to provide the DFN services. One server will be reserved primarily for the disciplines involving a large volume of communications file transfer, remote job entry, while the other server is provided as back-up for remote cooperation requirements (E-mail), for access to research data bases (Dialog), and for the support of indigenous development work.
- The other facilities will be linked up via additional X.25 switching relays using leased lines and PAD units.

In an initial stage the technical equipment required for the linkup to the WIN and the provision of DFN services in conformity with the FRG's foreign trade laws will be installed in the DFN Association's office in West Berlin. Once the restrictions involved are lifted, the technical equipment will be taken to the GDR in a second stage, and additional server computers will be put into operation in the various facilities there.

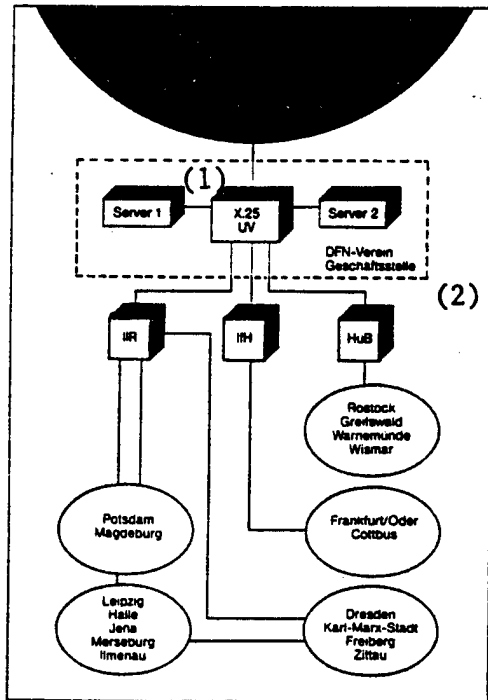

Fig. 2: Pilot Project in Planning

Key: 1. X.25 switching relay —2. DFN Association office

In parallel with the step-by-step creation of the communications infrastructure, scientific and technical tasks that will make for rapid adjustment to the standard reached by the FRG in telecommunications must be performed. They will be based on the DFN Association's development program for the installation and operation of the research network. It includes complying with European activities in general and those within RARE [Associated Networks for European Research] in particular.

[passages omitted]

Danish Research Center Reorganizes, Focuses on Environment

90WS0076A Copenhagen BERLINGSKE TIDENDE
in Danish 23 Jul 90 pp 6-7

[Article by Jens J. Kjergaard: "Riso Trimmed To Meet Demands of the Nineties"]

[Excerpt] Riso Research Center is on a diet. The institution is to be slimmed down and strengthened, so that it can hold up better in the super-tough international competition. In the future its strength will be gathered around eight application fields, which will hopefully live up to the expectations. In addition, strategic alliances that are also beneficial to Danish business will be established. A new division of labor is on its way for research.

But the conversion process is by no means painless. Eighty-five employees have received notice that they are to be laid off. The first employees will leave Riso in the fall, the last ones say goodbye in 1992. The cutbacks are deepest in the administrative functions, particularly in the areas which are not in as much demand as before by the research departments. The marketing office will disappear. The management is convinced that the reductions are a necessary precondition for a positive development at Riso.

Order in the Economy

Now there must be order in the economy so that the overall level of activity can be maintained, wrote director Hans Bjerrum Moller in the July issue of the personnel newsletter. Additional demands for cutbacks may be issued. The management has not received any guarantees.

The leadership of the country's major sector research institution warns that a continued reduction in budget appropriations will constitute such a serious drain on the established stock of knowledge that the quality or relevance of the research cannot be maintained in the long run.

This year, Riso will earn only 140 million kroner from contracts, while 230 million will come directly from the public coffers, meaning 38 percent is activity that pays for itself. The Riso Research Center will therefore continue to have a considerable range, but the scarce funds will cause efforts to be concentrated to fewer projects. The 1990 reorganization will give the center a profile, so it will be clear for what we stand and how we can serve. Research institutions must adapt to a changing community.

Strategic Research

Riso is in the middle of the spectrum between basic research and development work. The emphasis is on what is called strategic research—meaning gathering knowledge and experience, which in the intermediate term makes it possible to solve concrete tasks.

"In some way it worries me that 40 percent of our total activity is financed by contracts," says Jorgen Kjems, research director and head of the new Environmental Department.

"The contracts with the EC help guide our own research. Every time we sign a contract our hands are tied, so it must be understood that we must add to it from our own meager funds.

"We are happy about our tasks for Danish activities, but—with all due respect for Danish commerce—industrial people are particularly interested in problem solving in a very short time, that is to say within a horizon of two to three years. We would very much like to have that kind of projects, but those are not the ones that create renewal in the form of new technologies.

"The renewal may grow from research that to a large extent is open. As open as it is possible when the imagination is to play within eight application areas. For example, ideas may be based on using the DR3 reactor, a useful research tool which may also interest foreign researchers.

"We can only raise our level of knowledge by associating with the best in the world, by taking to conferences with things others can use, and ourselves gathering ideas from other fields. This will not succeed if Danish researchers and business people confine themselves within closed circles."

New Knowledge Center

At Riso there is excitement over the new neighborly relations with Denmark's Environmental Studies.

This creates a center of knowledge which could be of major importance to research and industry, and in the long term will open up even greater prospects if the European Environmental Agency moves here.

The establishment last year of the Center for Advanced Technology was a step on the way toward increased cooperation between industry and research. The intent is for interesting activities combined with researchers at Roskilde University, Denmark's Environmental Studies and Riso to bring ideas to the point where actual production may be initiated.

The authorities behind the new public research programs, both Danish and joint European, stress the participation of industry to an increasing extent, and that is something we can only be satisfied with, the Riso management points out. In particular, the center has major expectations for the cooperation between power plants and industry regarding the development of fuel cells. A project which was begun in 1989 under the EFP, that is to say the Energy Research Programs.

In 1989 Riso entered a strategic alliance with DK-Teknik on combustion research, and the center hopes to establish corresponding agreements with other institutions and activities.

Riso is among those who were part of the MODECS initiative, a forum where institutions and private activities design and test molecules for the medical and environmental fields.

Windmills Have Become High Technology

"Denmark is actually cleaner now than when I was a boy—in a land area with dung hills, open sewers and swarms of flies. The creeks may have been in better condition, but the villages were not," says research director Jorgen Kjems.

"Riso will concentrate to an even greater degree than before on development of environmental technology, because the environmental crisis can only be solved with technology," the director adds.

He is looking forward to future close cooperation with Denmark's Environmental Studies (DMu), which is just about to move to the research center, but he stresses that Riso wants a different profile than DMu.

"Our main task is not to identify the problems. We have a tradition of large experimental projects and want to create the background for the engineering solutions which can reconcile us with nature. It is very satisfying to be a part of developing new technology which does not come about solely for profit."

Offer to the East

Riso's researchers have a lot to offer in the cooperation with the new Eastern Europe, not least in the field of atmospheric chemistry. The Baltic countries, Poland and the GDR are particularly interested in careful study of the ways of pollution, which means, among other things, controlled emissions of a harmless but easily recognizable trace material such as SF₆, sulfur hexafluoride.

Plans are also being made for continuing the work on the large wind atlas for the western regions.

"Windmills are a useful contribution to the energy supply; in this field Denmark is in the forefront, and we don't voluntarily want to give up our leader's shirt. We are arriving at better, smoother materials and the wings are designed with the aid of computers, so that they can get a maximum efficiency without breaking. It's a matter of renewal, and today wind mills may be described as high technology, just as demanding as the development of aircraft, for example," says Jorgen Kjems.

Riso Washes Toxic Earth Completely Clean

If the Environmental Administration is to be believed, there are about 80 million tons of polluted soil in depots around Denmark. And one-tenth of this stored dirt is so toxic that it is necessary to purify it. But how? The Riso Research Center has the answer.

As a spin-off from a study that was to show whether it might pay to wash out Greenland uranium, methods were found which guarantee that substances that are hard to break down are rendered harmless and eliminated. The process is called wet combustion or wet oxidation.

In 1988 Riso, in cooperation with NKT A/S began the development of the highly effective cleansing process, which in principle can keep going without adding outside heat. This has now progressed almost to the point where the research center is allowing itself to be detached and cash in the licensing money.

The organic material in the sludge itself delivers the energy for the breakdown, which takes place at 280 degrees and under high pressure.

The first attempt at purifying tar-containing soil was undertaken in 2-liter autoclaves, but in the next experiments the researchers were able to treat 3 cubic meters an hour.

A winding, kilometer-long, pipe system was constructed at Riso.

Similar installations can be placed elsewhere in Denmark—or on a ship.

First, pieces of metal and plastic are separated out. Next, rock is sorted out in a washing drum. What remains is fine clay with all the toxic substances which can be destroyed in wet combustion.

The pipes emit water, carbon dioxide—and formic acid, butyric acid and acetic acid, which can be broken down biologically by the starved bacteria in an ordinary purification plant.

“Riso would like to join projects which develop new technologies in cooperation with industry. But we are only part of the pre-competitive phase. The actual production we let others handle. This yields the licensing money; the negotiations about these conditions can be tough, but normally we are satisfied with the agreements we conclude,” says research director Jorgen Kjems.

Riso's Eight New Departments

- Combustion Research
- Meteorology and Wind Energy
- Systems Analysis
- Environmental Research
- Nuclear Safety Research
- Materials Research
- Solid State Physics
- Optics and Fluid Dynamics

Changes Planned for German Research Institutes, Academy of Sciences

91WS0024A Landsberg PRODUKTION
in German 6 Sep 90 p 3

[Comments by Former GDR Research Minister Frank Terpe: “Changes in GDR Research—Ambitious Goals, Scarce Resources”]

[Text] BERLIN (Im)—GDR research minister Professor Frank Terpe has stepped down. However, this politically motivated move does not change the need to reorganize GDR research and the commitments made in this respect. Shortly before stepping down Terpe told PRODUKTION about the initiatives that had been undertaken and the next steps.

Research in the GDR is concentrated in two areas. These areas will also be the direct responsibility of Terpe's potential successor: industrial research and the Academy of Sciences. “We told the Academy that it must become a more regional institution and cannot claim to be a national academy, i.e., an academy for all of Germany,” said Terpe. “This is not possible for a variety of reasons including our political past, since the Academy had succumbed in many respects to the political pressure exerted by the SED [Socialist Unity Party of Germany] regime.”

For this reason alone the Academy cannot claim national status, said Terpe. “However, the scientists at the Academy have the right to be treated with consideration. The Academy has many very competent research groups even if a few officials in the Federal Republic—who unfortunately sit in influential positions—do not want to recognize this fact. We would like to point out that science in the GDR should be viewed as a multi-faceted field; we cannot accept a wholesale dismissal.”

Therefore, the Academy will be split up into a small “society of scholars” which will be integrated into the well established German Academy structure, and into a considerably rejuvenated association of 59 institutes with a total staff of approximately 24,000.

This association of institutes is to receive top priority. It must be organized so that it will fit smoothly into the structures of the Federal Republic once Germany is reunited. After reunification, it may have to be financed jointly by the federal government and the five states in the Eastern part of Germany. All steps in this direction will be taken in coordination with the Federal Ministry of Research and Technology (BMFT), the research institutions in the Federal Republic and the Science Council.

However, the moratorium until the end of 1991 which was negotiated for the Academy does not exclude personnel changes before that. A research and development staff of approximately 140,000 is affected by the restructuring measures which are under way. This includes the 84,000 scientists in industry (approximately 60 percent of all researchers in the GDR), almost 24,000 employees of the Academy and more than 36,000 scientists in other research institutions.

Close to 3,000 employees whose age makes them eligible for early retirement were encouraged to accept the early retirement offer. For women, the required age is 55, for men, it is 60. In addition, those employees who have not yet been able to bring their R&D work up to international standards were urged to find other employment; for instance, with technical organizations or small or medium-sized innovative firms which still need to be established.

To facilitate these efforts, a West German institute is conducting courses in business administration. Upon completion of the course, participants will receive a certificate. The idea is that such courses could open up opportunities in the market economy for interested persons who used to work in academic institutions.

At the same time, various institutions are returned to private ownership which as Terpe put it: “...were made part of the Academy due to an ill-advised science policy of the SED, but which do not belong there.” Those institutes affected include the “Center for the Building of Scientific Equipment” and the publishing center of the Academy with a staff of approximately 5,000.

Currently, a consulting group from the Federal Republic is advising them on free market strategies, while the

research ministry is only providing start-up financing. However, the question who owns the property on which these facilities are located is still open, since the sites are owned by the government and not by the people. Therefore, the question of how and whether these enterprises can transfer these properties into private ownership to be used as collateral for bank loans must still be clarified.

The Academy institutes which are located outside Berlin, primarily in Saxony (25 per cent), will become research institutes of the State of Saxony. Although the State of Saxony will not be reestablished until October, all financing issues, for instance the extent to which the individual states will participate, must be solved before that date. Academy institutes which used to be part of universities are to be returned to academic institutions again. This will be done in cooperation with the Ministry of Education.

When asked about any plans to integrate individual research institutes into the Max Planck Society or the Fraunhofer Society Terpe answered: "Currently, the Science Council which now includes GDR members is evaluating all GDR institutes. We expect this evaluation to be completed by the end of 1991; at that time, specific decisions will be taken. If the evaluation is favorable, the Max Planck Society or the Fraunhofer Society might conceivably want to accept a number of institutes."

Unfortunately, in the short term the GDR Ministry of Research has only very limited funds for financing research. The Academy receives only the funds necessary to ensure basic financing for 1990, to avoid any layoffs and to continue current R&D projects until the 1991 moratorium expires.

However, the GDR Ministry of Research will plead for the allocation of additional funds for research and technology in the GDR section of the all-German budget for 1991, so that the GDR will be able to start catching up with the West in specific areas. In the area of analyzers, for instance, the GDR is currently ten years behind the international standard.

The funds which are presently being used for current operations come from various sources. The BMFT, for instance, provided 20 million German marks [DM] for the establishment of technology centers in the GDR. The GDR Ministry of Research provided the same amount for this purpose, because this is a joint project. Following Terpe's suggestions, the BMFT is also financing various awards for young GDR scientists who were held back in their research efforts by the SED regime during the past few years.

Although Terpe acknowledges that with the monetary union the Federal Republic made a great contribution towards German unity, he still deplores the paucity of funds for restructuring the research arena. In the second half of 1990, the GDR Ministry of Research has DM690 million available to support research. Most of it goes to the Academy of Sciences. Industrial research groups receive a mere DM 200 million with the Ministries of

Research and Economic Affairs jointly deciding on the appropriation of these funds.

However, the lack funds for reorganizing industrial research is currently not the only major problem. The state-owned combines which are reorganizing into corporations often do not want to assume responsibility for the research groups. They are being dropped like a hot potato. Many projects are being cancelled or stopped; in many cases, continued payment of salaries is uncertain. The researchers themselves have not had time enough to make arrangements with West German companies to ensure their economic survival.

Research efforts in the GDR will have to shift emphasis somewhat if only for the fact that self-sufficiency—an SED goal—is no longer required. Certain research groups, e.g., in the field of microelectronics, which produced astounding results under much inferior and extremely difficult conditions must shift their research focus. "If you want to evaluate the performance of research and development teams," says Terpe, "you must consider the working conditions as well."

It is too early to say which R&D activities will be discontinued completely. Terpe thinks that many problems will take care of themselves in a free market economy. It is possible to make suggestions, but in the final analysis the research groups themselves must find a way to work together with industry by learning marketing techniques and by finding out which activities are needed in the marketplace.

When asked if and how joint research projects with the Soviet Union will be continued, Terpe answered: "All civilian cooperative research projects with the Soviet Union—and there are more than one hundred of them—will be continued. These responsibilities will be assumed by the Ministry of Research of a unified Germany and by the GDR researchers involved. However, modification of such contracts is possible. Military research does not fall within our area of responsibility. I assume this is the responsibility of the Ministry of Defense, but I am not sure about that. However, one thing I am sure of: We no longer have any cooperate military research projects with the Soviet Union."

Dutch Government Increases Technology Funding

*90AN0384 Amsterdam COMPUTABLE in Dutch
22 Jun 90 p 11*

[Article by COMPUTABLE correspondent: "Budget Surplus From Andriessen To Be Allocated to JESSI; Also More Funds for Technological Policy"]

[Text] The Hague—In the next five years, Minister J. Andriessen (Economic Affairs) intends to add an extra 275 million guilders to the Dutch contribution to the Joint European Submicron Silicon Initiative (JESSI). The budget of the Ministry of Economic Affairs is expected to show a total surplus of 1.4 billion guilders in the next five years.

A major part of this money might be used to intensify technological policy. This is suggested by leaked documents which were drawn up by the Ministry of Economic Affairs with a view to the upcoming budget discussions and the strength/weakness analysis of the Dutch economy, which is soon to be published.

This windfall comes at the right time for the JESSI project, now that the Dutch Government has to finance part of the deficit caused by the EC's reduced contribution. Initially, the EC was expected to finance one-quarter of the project, but this turned out to be only one-eighth.

Between now and 1994, the Netherlands will have to contribute a total of 175 million guilders to this project. The remaining 100 million guilders can be used for Dutch subcontractors to JESSI (except Philips). In addition to JESSI, an extra 265 million guilders will be appropriated for strengthening the technological policy, 85 million guilders of which are intended for the Program for Company-Oriented Technology Stimulation (PBTS), an incentive program used by a lot of companies in the area of information technology. It is a well-known fact that the PBTS's information technology section was heavily over-tendered last year. Some 180 million guilders will be attributed to the Technological Development Credits (TOK). The Institute for Applied Scientific Research (TNO) can count on an additional 36 million guilders through 1996. The remainder of the surplus will be allocated to environmental policy and, to a lesser extent, to the shipbuilding and tourist industries.

However, it should be admitted that the surplus did not entirely come out of the blue. Last fall, Hoogovens already seemed to be considering the early repayment of loans granted by the state. Furthermore, extra money is also coming in from casinos, regional development companies, miners pension funds, and various other sectors.

SUPERCONDUCTIVITY

Netherlands: Superconducting Josephson Junction Developed

91AN0036 Rijswijk POLYTECHNISCH WEEKBLAD
in Dutch 30 Aug 90 p 7

[Article by Rene Raaijmakers: "Broader Application of New Superconductors Thanks to Process Developed at University of Twente"]

[Excerpts] Last week, researchers from the University of Twente announced that they had succeeded in making high-temperature Josephson junctions using a repeatable process. As the smallest "active" building block, this superconducting device is indispensable in, for instance, highly sensitive magnetic sensors and in digital superconducting electronics with switching times in the picosecond range (one billionth of a second).

In August last year, researchers from the Netherlands Central Organization for Applied Research (TNO) managed to make the off-season pages with the news that they had the means to make superconducting thin films. But no sooner had they taken the chemicals out of the cupboard, than it was announced that the Low Temperatures department of Twente University had already finished the job. In August, at a time when TNO had not yet grown any film at all, Twente hit the headlines with three breakthroughs: very thin, high-quality films; a multilayer structure; and, as a third innovation, the highest possible current density. They succeeded in sending a current of 8 million amperes per square centimeter through a layer which was barely one hundredth of a millimeter thick. [passage omitted]

The research team [of Dr. Horst Rogalla] has now succeeded in making Josephson junctions using $\text{YBa}_2\text{Cu}_3\text{O}_{7-x}$ (abbreviated YBCO). This is the material with which Chu caused a stir in March 1987 during the annual meeting of the American Physical Society, because it is superconducting at only 92 degrees Kelvin (minus 181 degrees Celsius), i.e., 15 degrees above the boiling point of nitrogen.

Tunnel Effect

More particularly, the Twente team has produced proximity-type junctions. These small components have slightly different properties than conventional junctions, whose tunnel effect was predicted in 1962 by Brian Josephson, who was awarded a Nobel Prize for this in 1973. The layer structures developed at Twente consist of two superconducting layers with a normally conducting barrier in between [SNS junction]. In "real" tunnel junctions, the barrier is an insulator [SIS junction]. In SNS junctions, the quantum-mechanical interaction between both superconducting layers is called coupling. According to Rogalla and Dr Gerrit Gerritsma, main lecturer at Twente University, this coupling effect is as usable as the tunnel effect in SIS junctions, in which electron pairs (Cooper pairs) are tunneled through the insulating layer. [passage omitted]

How about these junctions developed in Twente? Roughly speaking, the manufacturing process is as follows. Two layers are deposited onto a substrate: a superconducting YBCO layer and a PrBCO layer on top of it. The substrate is an insulator. These layers are then covered with a mask. In places which are not covered by the mask, the normal and superconducting layers are then etched away by means of an argon-atom beam. Thus, an edge is formed and an YBCO strip is laid bare. A thin PrBCO junction layer and another YBCO layer are then sputtered over the etched gradient, thus obtaining the coupling effect through the thin junction layer [in between both superconducting layers].

Chinese scientist Ju Gao performed this master stroke. Apparently, he has it in his fingers. Ju Gao was the very same man who last year managed to grow very thin films. In Twente, this achievement is claimed to open the whole applications field of superconducting electronics, but this remains to be proven. Rogalla has hedged against possible

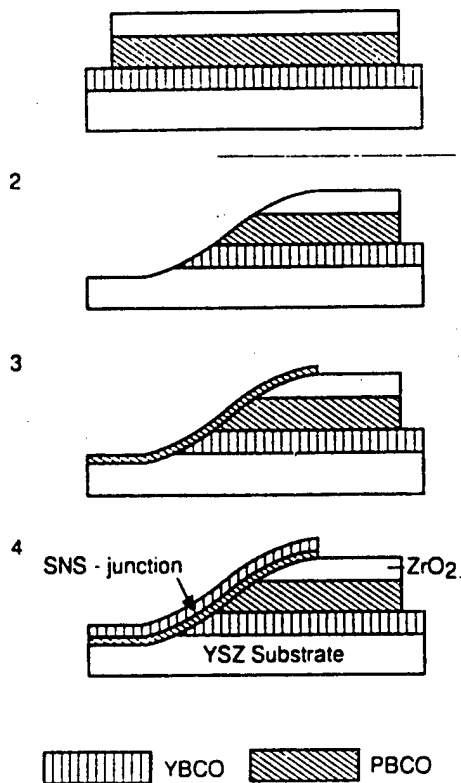

The Low Temperatures department of the University of Twente produced a ceramic Josephson junction by covering an YBCO and PrBCO multilayer structure with a mask (1). The layer structure was locally removed by bombardment with an argon atom beam at an angle of 45 degrees (2). The gradient thus obtained was covered with a thin layer of PrBCO barrier material (3) and then with a layer of superconducting YBCO (4).

mishaps by stating that a lot of research remains to be done. This research will focus mainly on varying the parameters for manufacturing the junctions. Indeed, this junction lends itself better to experiments with layer thicknesses, doping, and etching techniques than IBM's junction. Besides varying the surface, few experiments can be done with grain boundaries. [passage omitted]

TELECOMMUNICATIONS R&D

D2-Mac on Shaky Ground as European HDTV Standard

91WS0043A Frankfurt/Main FRANKFURTER ZEITUNG/BLICK DURCH DIE WIRTSCHAFT in German 30 Oct 90 p 8

[Article: "Without Attractive Program Offerings D2-Mac Cannot Become Television Standard: Federal Government Wants To Hurry Along Its Introduction With a Joint Declaration of Intent From the Participants"]

[Text] Frankfurt, 29 Oct—To date, several hundred million German marks [DM] have been invested in the development of high definition television; however, success has not been achieved yet. European TV manufacturers are noticeably nervous. In the opinion of those knowledgeable about the sector, the improvements promised through the introduction of the D2-Mac TV standard are not easy to recognize when compared to the PAL [programmable array logic] system. Often it is not obvious that the digital sound is actually better because the audio components of existing TV sets (particularly the older ones) are in some cases not advanced enough and also the sound track of many programs is quite mediocre.

On the other hand, D2-Mac represents an intermediate step toward HDTV. In 1991, when the first TV receivers with the wide picture tube in 16 x 9 format become available, they would already be capable of showing programs that fill the screen—provided the broadcasting companies and the private broadcasters are then transmitting in D2-Mac. In any case, to date, D2-Mac TV is playing via TV Sat 2 with the public virtually excluded.

There, there are only four channels (1 Plus, 3Sat, Sat 1, and RTL plus) which can be seen via conventional ground transmitters or on cable in the usual PAL. In contrast, direct reception via TV Sat 2 requires an expensive satellite system and a receiver suitable for this standard. The viewer can obtain these two items only by investing approximately DM2,000. For the viewer, that means high cost with limited use. And the expensive satellite which cost approximately a half billion Deutsche marks is not being adequately utilized.

Federal Post and Telecommunications Minister Dr. Christian Schwarz-Schilling succeeded in persuading TV manufacturers, broadcasting companies, the two largest private telecasters, and the German Post and Telecommunications Ministry to sign a declaration of intent which is supposed to save the D2-Mac standard. According to it, the broadcasting companies are to present the first and second channels on TV Sat 2 and they are obligated to broadcast some programs in the 16 x 9 format starting at the time of the International Broadcast Exhibition in 1991, and, for this, to conclude four-year exploitation contracts for two channels on the TV Sat and also to transmit digital sound radio (DSR) over a third channel.

The TV manufacturers are supposed to offer reasonably priced D2-Mac receivers or even modems for older sets. According to Schwarz-Schilling, they also must be involved in transponder rentals, which would be an absolutely new development. The German Federal Post and Telecommunications Ministry will likewise contribute to the costs of TV Sat 2 and feed more programs into the broadband cable using the D2-Mac standard, as well as the French channels transmitted with that standard which now run on the satellites TDF 1 and 2.

The Post Ministry, for its part, is obligated to make arrangements through negotiations with the German Laender so that the broadcasting of the TV programs mentioned will be less expensive. However, the old version of the agreement between the Laender and the national government concerning the use of the TV Sat still prevents that.

And, the Union of Broadcasting Companies (ARD) has reservations: Retrofitting studios for the new picture format and the new form of modulation are considered too expensive, and satellite broadcasting would lead to horrendous additional payments for film broadcast rights, since the nine Laender would then be involved.

However, if no attractive programs can be received from TV Sat 2, the intermediate step D2-Mac would be "dead" because of the situation and, therefore, all of the effort expended thus far for technical introduction of this standard would have been wasted, argue industry representatives. Cornelis Bossers (Philips) and Dieter

Kunkel (Thomson) stress that much has been invested, that there will soon be both conventional PAL color receivers in the current 4 x 3 format with integrated D2-Mac components for an added cost of barely DM300 more and built-in decoders for the same DM300 or add-on decoders for cable reception for DM699. Beginning early next year, Thomson will offer color sets for direct satellite reception for an added cost of DM649. For this all that is needed is the connection of a small parabolic antenna—which costs approximately DM300.

But, all of this only makes sense if truly attractive programs are broadcast in D2-Mac via TV Sat 2. Whether the first and second channels which are receivable everywhere with the usual quality are to be included in that may remain an open question. Nevertheless, everyone is still committed to pursuing HDTV. Alain Gomez, Thomson CEO, recently announced approval of an additional Fr 3 billion (approximately DM1 billion) for HDTV development.

TELECOMMUNICATIONS R&D

CSSR: Trial Operation of APRES 01, APRES 02 Telecommunications Gear

90WS0100A Prague TELEKOMUNIKACE in Slovak
Jul 90 pp 107-109

[Article by Eng Milan Kovacic, Eng Vladimir Murin, Communications Research Institute, Banska Bystrica branch, and Eng Marian Rafaelis, Telecommunications Directorate, Bratislava: "Experiences From Test Operation of APRES 01 and APRES 02 Equipment"]

[Text] Microcomputer based, modular APRES equipment with flexible installation of I/O circuit interface units to the telecommunications network makes it possible to implement efficient monitoring and diagnostic systems for telephone network maintenance and control where there is a need to read and process large volumes of bivalent information and to control large numbers of actuating units in real time.

Individual components of this equipment can be customized to create an independent functional system by adding extra equipment and software.

The basic configurations of the equipment, designated as APRES 01 and APRES 02 are designed to measure operating loads in the Czechoslovak unified telecommunications network [JTS].

- APRES 01 measures operation of circuits and c-wire lines. It can handle 960 measured inputs, and allows the modular installation of boards for connecting equipment to be measured in 60 unit increments up to the above maximum.
- APRES 02 measures operating load on groups of 2k ohm registering resistors. It has a connection for 60 measured inputs from a maximum of 1,200 pieces of equipment. It also has the capability to expand the maximum number of measured units for PK and MK central offices to 7,200 using the or bus.

The goal of the tests was to verify the technical and operating parameters of prototypes of the above units based on announced base technical specifications [ZTP] and to obtain operating experience related to their potential use in the communications sector.

The tests were organized by the Communications Research Institute [VUS], in conjunction with the Telecommunications Directorate in Bratislava.

Basic Information About the Equipment

The equipment prototype consisted of a NZD power supply located in a 1/2 modular electronic mounting plate and a VR input and control plate located in a 1/1 modular electronic mounting plate. The design of these plates is used in all second generation Czechoslovak communications systems. It was adapted for use with

microelectronic components in ZZUV equipment and is used in the APRES equipment.

The required functionality for APRES 01 and APRES 02 resulted from a modification of the VR plate by adding additional components to the basic configuration of the plate, additional I/O circuits (VOZ [transmitting negative logical signals], VOA [transmitting analog signals]), and upgrading the related EPROM software.

APRES 01

This piece of equipment allows the measurement and processing of S-wire telephone network operations in first and second generation central offices. VOZ boards are used to connect to measurement points. The measurement and processing of data from measurement points is performed automatically after creating a data base of measurements from specific pieces of equipment or groups of equipment from the phone network and requesting the type of measurement.

The following are measured:

- Operation of equipment and groups of equipment;
- Group statistics;
- Equipment statistics.

The user defines how to request a measurement and the desired output report based on the measurements. Output reports provide information about specific measured devices, circuits, or lines, or about groups of measured equipment, circuits, or lines.

Communications with the operator is through a monitor with a keyboard, printer, a tape puncher, and a cassette tape player.

Figure 1 shows the basic equipment of APRES 01. It is made up of basic microcomputer control boards, interface boards for connecting peripherals, and a multiplexer for connecting to I/O circuit units. Connections to the environment being measured is enabled by input circuit boards for transmitting negative logical signals. The VOZ boards make it possible to read information from a maximum of 960 measurement points.

Programs for controlling measurements, communicating with the operator and peripheral equipment, and for equipment diagnostics are located in a 32 kilobyte EPROM. Measurement data is stored in dynamic RAM [Random Access Memory], which reaches 64 kilobytes if paging is used.

The data base for a specific connection and the designation of measurement points in a central office can be stored for multiple uses on a tape for the cassette recorder.

APRES 02

This unit measures and processes telephone network operating loads in first and second generation central

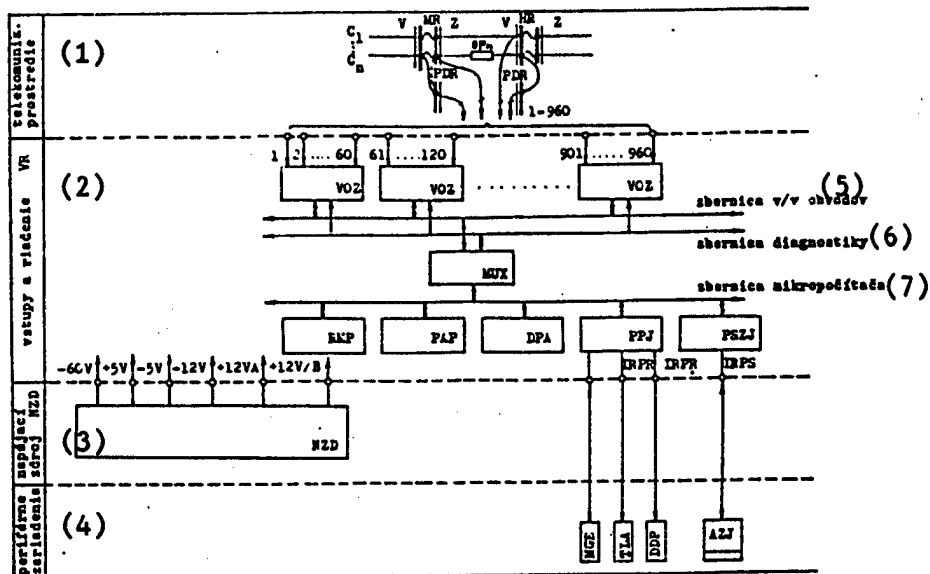

Figure 1. Basic APRES 01 Configuration

Key: 1. Telecommunications environment—2. VR inputs and control—3. NZD power supply—4. Peripheral equipment—5. I/O circuit bus—6. Diagnostic bus—7. Microcomputer bus

offices using existing measuring points. It is connected to measurement points using a VOA board. Each measuring point can be made up of a maximum of 20 2k ohm multiple registering resistors. The measurement and processing of data from the measurement points is automatic after creating a measurement data base based on specific pieces of equipment from the telephone network and requesting the type of measurement to be performed.

The following is measured:

Operating load of groups;

—Group statistics.

The user determines the means of requesting a measurement and the desired output report based on the measurement information. The output reports provide information only about the groups of measured equipment, circuits, or lines.

Communication with the operator is implemented the same way as for device APRES 01.

Figure 2 shows the basic configuration of an APRES 02. It is comprised of basic boards. Connection to the environment being measured is enabled by a board of input circuits for transmitting analog signals. This architecture allows the unit to read information from 60 connected measuring points.

Programs for controlling measurements, communicating with the operator and peripheral equipment, and for equipment diagnostics are located in a 32 kilobyte

EPROM. Measurement data is stored in dynamic RAM with a capacity of 64 kilobytes.

The data base for a specific connection and the designation of measurement points in a central office can be stored for multiple uses on a tape for the cassette player.

Prototype Tests

The tests of the APRES equipment were conducted at the Bratislava Supervisory Center. This site was chosen because it:

- Supervises and performs other tests on connected trunk groups and measures operating loads;
- Performs constant monitoring of the telephone network and its equipment;
- Performed the modifications necessary to connect certain circuits and lines to the APRES equipment (S-wires, registering resistors).

The prototype equipment manufactured by Karlin Tesla arrived at the VUS in April 1988. This prototype, consisting of one NZD power supply and one VR input and control plate built into a modular stand, were installed and tested during the months of May and June 1988.

The assembly of the prototype and its startup at the test site was performed by VUS employees on 22 June 1988. During assembly an inspection was performed of the connection of P51 central office S-wires to the inputs of the prototype.

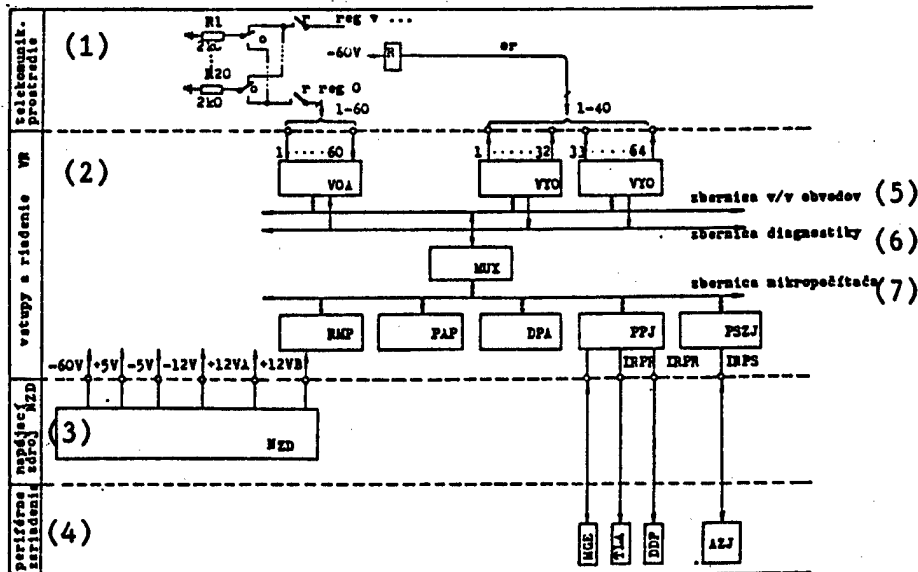

Figure 2. Basic APRES 02 Configuration

Key: 1. Telecommunications environment—2. VR inputs and control—3. NZD power supply—4. Peripheral equipment—5. I/O circuit bus—6. Diagnostic bus—7. Microcomputer bus

The functional test was divided into two stages. In stage I tests were performed of the technical and software components of the APRES 01. In stage II tests were performed of the technical and software components of the APRES 02. Tests in both stages consisted of:

- Comprehensive prototype tests;
- Operational tests.

The operational tests were devised by the employees of the Supervisory Center based on "Operator Tasks for APRES Equipment" developed by the VUS. The operating organization designated one person to be responsible for conducting all the tests. This person was in charge of creating configuration data, starting and completing the measurement cycles, processing and archiving the output reports. The other employees took turns evaluating equipment performance over time based on output reports.

Downtime resulted from defects in:

- Peripheral equipment or the connections of this equipment to the VR plate;
- The equipment in the VR plate;
- The equipment in the NZD plate;
- The power system of the facility;
- From careless operator actions in the vicinity of the power feed.

During the tests changes were made to the software as needed based on comments of the employees at the testing organization.

Evaluation and Interpretation of Test Operations

The APRES 01 and APRES 02 equipment was tested in actual operation in cooperation with the P51 central office on US-2. The equipment was connected permanently to the telecommunications environment being tested. The tests covered the following areas.

- Equipment functions and operator instructions.

The way to select specific functions is presented concisely and accurately in choice tables and contributes to the overall ease of equipment operation.

- Creation and storage of configuration files.

The technique is documented concisely and well. The capability of combining individual measurement points into a single group is a great advantage. No problems were experienced communicating with the cassette tape recorder and no errors occurred.

Measurement output.

The APRES 01 unit provides the measurement results in 15 output reports, and the APRES 02 unit in 11 output reports.

At the start of the tests, based on comments from employees at the testing organization, the software was changed so that the numbering of the 60 interfacing

output connectors in the central office was the same as the numbers of the input circuits on the VOZ board.

Other software modifications included changing the format of the punched tape for the central data collection and operating load in the Computing Center at Ceske Budejovice, expanding the number of programmable groups from 22 to 32, and transmission of the data for the tape punching equipment. All these modifications improved the usability of the prototype equipment.

During the tests all output reports were run.

- Transmission and recording of measurement output reports on peripheral equipment by printing the output reports and diagnostic programs for pertinent peripheral equipment.

The most frequent problems were caused by low reliability of attached peripheral equipment, especially the CM 7209 monitors and DT 105S punchers, both imported from Poland. During the tests we replaced three CM 7209 monitors and two DT 105S punchers. Finally this puncher was replaced with a FACIT 4070 puncher. Communication with the CONSUL 2111 printer was without problems.

- Diagnostic programs for specific peripherals always reliably pinpointed peripheral equipment problems.
- Reliability and stability of technical specifications.

At the beginning of the tests the input parameters of the measured signal (number of changes, total length of changes, etc.) were tested independently using instruments developed by VUS.

The failures demonstrated by the prototype were caused by:

- Low reliability of peripheral equipment (CM 7209, DT 105S);
- The power system in the facility, which did not conform to Czechoslovak State Standard [CSN] 33 0123;
- Production defects in the PPJ and DPA boards of the VR plate (faulty soldering, broken wires in connecting cables where they are joined to the connectors, etc.);
- Defective components (K 573 RF5 integrated circuit, WK 16 414 optoelectronic coupler);
- Design defects on the PPJ board (failure to handle control signal inputs from the tape puncher);
- Design defects in the VOA board (reference current value of +12 volts, derived from power supply, was dependent on its changes).

The unreliability caused by defects in the power supply were corrected by modifying the NZD power supply. The specifications of NZD power supplies, however, cannot guarantee proper equipment functioning if the power

system of the facility does not maintain the conditions specified in point 1.5 of CSN 33 0123 (short term drops in power with amplitudes more than -20 percent U_B). This operating requirement was controlled by the instruments developed at VUS.

The design and manufacturing defects of the prototype were noted in the production documentation for APRES equipment.

To assure high software reliability, both versions of APRES include effective diagnostic tests for ongoing equipment diagnostics during measurement operations. This makes it possible to discover an equipment problem during operation and, furthermore, use diagnostics to pinpoint the defective component at the board level.

The test results show that this equipment meets all requirements in terms of technical parameters and operating characteristics identified in the approved ZTP.

Nothing happened during test operation to threaten operator safety.

Conclusion

One way to improve the quality of the telephone system is to install equipment that automates system monitoring. Measurements of operating loads is an important source of information for supervising operations, for ongoing operations management, and for system maintenance and design.

The equipment currently used in the Czechoslovak unified telecommunications network (registration counters, operations registers, MTP, AMTP, etc.) is obsolete and worn out.

APRES equipment allow the measurement and processing of phone system operating loads:

1. Using existing measurement points in first and second generation central offices. Measurement accuracy depends on how the measurement points are connected (maximum resistance in the connecting line of one ohm) and on the dispersion of measurement point parameters (registration resistors with a 5 percent nominal value tolerance). Output reports are affected by the measurement technique and provide information only about the equipment group being measured.
2. Using other measurement points (S-wires) in first and second generation central offices. Measurement accuracy is not dependent either on the means of connection or on the parameter dispersion of the measurement points. Output reports provide information about the piece or group of equipment being measured.

APRES 01 and APRES 02 equipment offers the advantages of computerized information processing and ease of operation.

In conjunction with the introduction of computer controlled equipment in communications operation we recommend that all operating organizations planning to use this equipment check their power supplies of connecting systems for compliance with CSN 33 0123.

New-Generation Digital Signal Transmission Device Described

90WS0096A Warsaw WIADOMOSCI
TELEKOMUNIKACYJNE in Polish Jul 90 pp 14-17

[Article by Bogdan Czajka and Mateusz Czygrinow: "The New Generation TCK30G Digital Transmission Equipment"]

[Text] After 10 years of manufacturing the TCK30 30-channel pulse-code modulation telephony equipment, the Wielkopolski Tele-Electronic Plants "Telcom-Telectra" [WZT] in Poznan has developed and started producing a new generation of this equipment. The equipment was developed by a team of WZT designers in cooperation with the Communication Institute in Warsaw. In developing the equipment, WZT availed itself of its many years of experience in producing and operating digital equipment, and the newest electronic components available in Poland, including CMOS integrated circuits and TTLs medium-scale integration with integrated coders and filters.

Application

The new generation TCK30G equipments multiply the number of telephone channels by time sharing channels. They provide 30 telephone channels by using two cable pairs of the type used as interexchange links for automatic analog and electronic exchanges. The equipments are designed for local, district and long-distance digital networks. The TCK30G line equipments can also be installed in one- and two-cable lines having non-coil loaded balanced lines with paper-air, styroflexic-air and polyethylene insulations and 0.5 mm to 1.4 mm diameter copper wires.

The maximum segment length for retransmission between two equipments energized locally depends on the cable parameters and is about 70 km for cables whose wire diameters are greater than 0.7 mm, and about 40 km for cables whose wire diameters are between 0.5 mm to 0.7 mm.

System Characteristics

The TCK30G equipments can be used to transmit telephone and telegraph signals as well as to transmit slow and medium speed data. Digital channels having a capacity of 64 kb/s can be created with the aid of special units incorporated within the terminal equipments.

These units permit duplex transmission of two independent streams of digital signals in channel slots 6 and 22 in a synchronous and asynchronous system in accordance with CCITT Recommendation C735.

The TCK30G multiplexers incorporated in the terminal equipments [UK] rack are available in two configurations:

- In the first configuration, the BK1, the TCK30G multiplexers are equipped with channel boards with individual integrated codecs for each voice channel.
- In the second configuration, the BK2, the TCK30G multiplexers contains a coder and decoder that is common to all 30 voice channels.

In both configurations, the TCK30G multiplexers are designed to operate with a common signaling channel system in channel slot S16 and may be equipped, via the signaling block [BS], with individual type-EM (Tron, Ron) signaling channels determined by a specific voice channel.

The TCK30G line route equipments contain locally powered line equipment incorporated within a line equipment [UL] rack as well as non-serviceable, remotely powered regeneration stations [SR] designed for installation in cable chambers. In the TCK30G system, the segments between regeneration vary from 1.5 km to 2.5 km depending on cable type and wire diameter. The attenuation of the segments adjacent to the locally powered equipment can vary from 0 to 20 dB at 1 MHz.

The TCK30G system includes the following equipment types:

- The UK-TCK30G1 terminal equipment rack (with two BK1 multiplexers incorporating individual codecs, and two BS1 signaling blocks);
- The UK-TCK30G2 terminal equipment rack (with four BK1 multiplexers incorporating individual codecs);
- The UK-TCK30G3 terminal equipment rack (with two BK2 multiplexers incorporating common codecs, and two BS1 signaling blocks);
- The UK-TCK30G4 terminal equipment rack (with four BK2 multiplexers incorporating common codecs);
- The UL-TCK30G1 terminal equipment rack (with six locally powered BR1 regeneration blocks);
- The SR-TCK30G1 apertured, remotely powered regeneration station (with six directional regenerators).

The terminal and line equipment racks are designed for continuous operation in automatic exchanges or tele-transmission stations at ambient air temperatures ranging from 0°C to 45°C and relative humidities ranging from 30 percent to 90 percent.

The regeneration stations are installed in underground cable chambers. The chambers are gas-tight and are not affected by atmospheric conditions prevailing at the installation site.

The TCK30G equipment satisfy current CCITT Recommendations G711, G712, G713 and G732.

The System's Technical Parameters

General Data	
— Number of channels	30 telephone channels 2 channels for signaling and synchronization
— Number of signaling channels per telephone channel	2
— Channel sampling rate	8 kHz
— Nominal frame time	125 microseconds
— Number of frames per multi-frame	16
— Number of channel digital slots	8
— Companding	24.1 dB
— Overload level	3.14 dBm0
Voice Channel Data	
— Frequency range	300 Hz to 3,400 Hz
— Levels in two-line system	
Input	-14 dBr to +1 dBr
Output	-11 dBr to +4 dBr
— Levels in single-line system	
Input	-8 dBr to +7 dBr
Output	-17 dBr to -2 dBr
— Nominal impedance Input and output	600 ohms balanced
— Channel psophometric background noise	-65 dBm0
— Interchannel crosstalk attenuation	-65 dBm0
Line Route Data	
— Line signal capacity	2,048 kb/s
— Line code	HDB 3
— Signal type	Impulse, 3 V +/- 10 percent amplitude, 244 ns +/- 30 ns duration
— Nominal line impedance	135 ohms balanced
— Remote powering	In-line via phantom circuit perimeter
— Remote powering current	60 mA or 70 mA -0 mA/-2 mA
— Remote powering voltage	maximum 200 V (+/- 100 V relative to ground or 240 V +/- 120 V to ground)
— Regenerator voltage	6.2 V
Equipment Power	
— Backup battery	48 V or 60 V +/- 10 percent

— Multiplexer power consumption	15 W
— Multiplexer and signaling block power	20 W
— Remotely powered equipment power consumption	21 W maximum

Climatic Conditions	
— Operating temperature range of racks	0°C to 45°C
— Relative humidity	30 percent to 90 percent
— Operating temperature range of regeneration stations	-30°C to 45°C

Dimensions	
— Equipment racks	
Height	2,600 mm
Width	120 mm
Depth	240 mm
— Regeneration station chambers	(without lead-in cable)
Length	592 mm
Width	312 mm
Height	300 mm

The Terminal Equipments Rack

The UK-TCK30G1-4 terminal equipments rack contains two or four channel multiplexers. Each BK1 multiplexer with individual codecs enables one to eight digital channels to be created having capacities of 64 kb/s in place of the equivalent voice channels. In addition, two channels having capacities of 8, 16/32 kb/s operating in an asynchronous system can be created for each system without reducing the number of voice channels.

Figure 1 is a block diagram of the BK1 multiplexer. The transmit portion of the multiplexer is shown in the upper section of the diagram, and the receive section is shown in the lower section of the diagram. Transmit signals are designated by an "x" and receive signals by a "y."

The multiplexer contains 22 modules consisting of 17 channel modules, and five transmit and receive control modules; a line code transcoder; and supervisory and control systems. Each D10 audio channel module bank serves two audio channels in a one- or two-line system and is interchangeable with the D11 or D12 digital channel modules. Module D11 permits two digital channels to be created having capacities of 64 kb/s with an asynchronous contact point in accordance with CCITT Recommendation G703, and module D12 permits one channel to be created with an asynchronous contact point and one channel with a synchronous contact point.

The interchangeability of modules D10, D11 and D12 apply to eight channels controlled by a channel slot according to the following order: 6-22, 14-30, 2-18 and

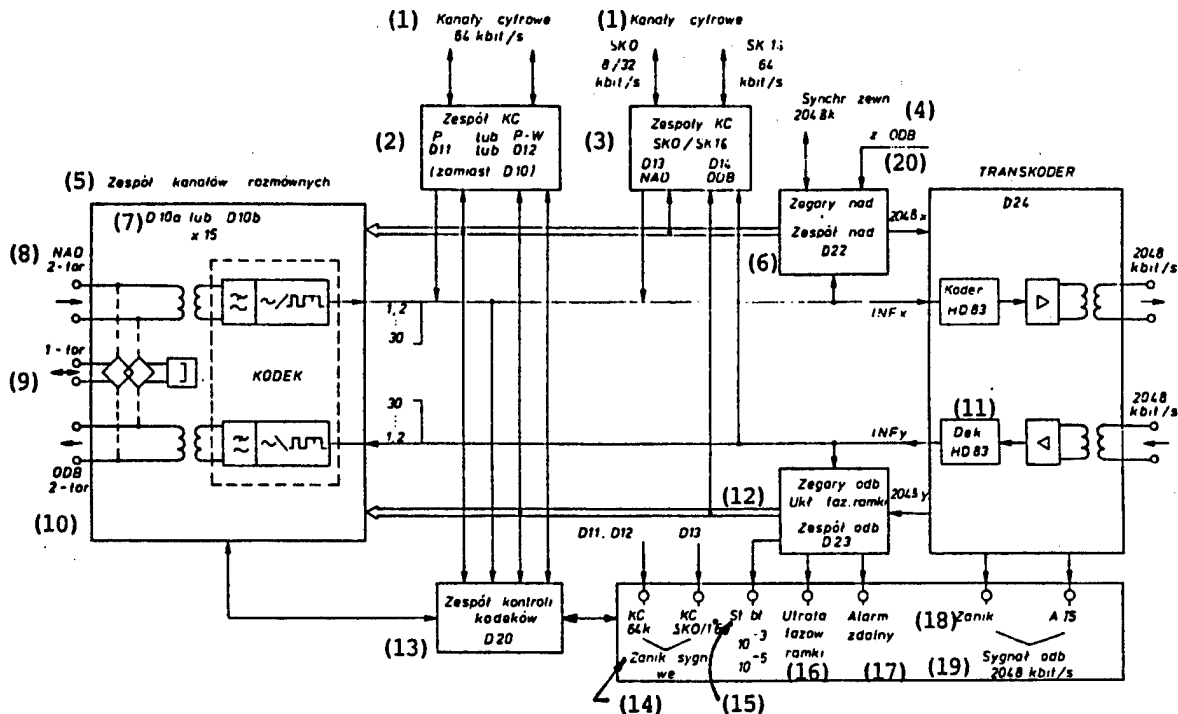

Figure 1. Block Diagram of BK1-TCK30G Multiplexer

Key:—1. Digital channels—2. Digital channel module; asynchronous contact point or synchronous contact point; D11 or D12 (instead of D10)—3. Digital channels; SK0/SK16; D13 - transmit; D14 - receive—4. External synchronization 2048—5. Voice channels bank—6. Transmit clocks; D22 transmit module—7. D10a or D10b X 15; codec—8. Transmit, 2-line—9. 1-line—10. Receive, 2-line—11. D24 transcoder; HD83 decoder; HD83 coder—12. D23 receive module; frame phase circuit; receive clocks—13. D20 codec control module—14. Input signal loss—15. [bit] error rate indicator—16. Frame phase loss—17. Remote alarm—18. Loss of frame phase—19. Receive signal, 2048 kb/s—20. From receive

10-26. Two digital channels with an asynchronous contact point are created in the SK0 and SK16 channel slots. Depending on how these channels are used, the following capacities can be obtained:

- In the SK0 channel: 8, 16 and 32 kb/s;
- In the SK16 channel: 64, 64, and 48 kb/s (bits of information).

The D22 transmit module includes a voltage controlled oscillator (VCO) that can operate in the following modes:

- Automatic operation;
- Triggered by an external 2048 Hz signal;
- Triggered by an external 64 kHz clock signal;
- Triggered by a clock signal generated within the multiplexer receive section;
- Triggered by a clock signal generated within the synchronous digital channel.

The BK2 multiplexer with common coding of signals is the functional counterpart of the BK1 multiplexer. The multiplexer contains 22 modules: 13 channel modules, and nine common and control receive and transmit modules. The BK2 multiplexer permits 30 voice channels to be created whose signals are processed in the common PCM codec.

Channel slot S16 is used to create a 64 kb/s digital channel with an asynchronous contact which can be used as a common signaling channel.

It is possible to create two additional 64 kb/s digital channels instead of channels K6 and K21 (modules E15 and E25), as well as one 8 or 16 kb/s channel using the free bits of slot S0 (module E27). Each voice channel bank, E10 or E20, serves three voice channels in a single-line system (module E10) or a two-line system (module E20).

Both multiplexers use a common transcoder, D24, which converts the NRZ code to the bipolar HDB3 code in the transmit section and vice-versa in the receive section. Via transcoder D24, multiplexers BK1 and BK2 are equipped on the line side with a 2048 kb/s contact point in accordance with CCITT Recommendation G703 that is designed to operate with 2048 kb/s line route equipment or higher order digital multiplying equipment. Each multiplexer has its own power supply.

The design of the UK-TCK30G1 and G3 racks and their cabling are fixed regardless of the number of blocks incorporated within the racks. This also applies to the UK-TCK30G2 and G4 racks. Each rack measures 2600 mm by 420 mm by 120 mm and contains eight shelves for mounting a system's individual blocks. Block subassemblies are connected via printed wiring (so-called plates), and blocks with frame and station (channel) cabling are connected via indirect connectors. The lead-in blocks (BD1) are located in the upper section of the frames and contain indirect connectors to connect the 2048 kb/s, digital, alarm and communication service signals to the station cabling.

The lead-in blocks also include executory alarm devices. The terminals used to connect power to the rack, as well as two fuse mountings for the rack power wiring are located in the upper part of the rack frame.

The Line Equipments Rack

A fully configured UL-TCK30G line equipments rack permits six digital line routes to be created to transmit data at a rate of 2048 kb/s. The terminal equipment of the line route

and the paired, locally powered equipment are contained in the UL-TCK30G rack. The contact points on the station side are designated for operation with BK1 or BK2 multiplexers at 2048 kb/s in the AMI bipolar code or HDB-3 code using 120-ohm balanced lines (in accordance with CCITT Recommendation G703).

From the line side, the equipment operates with balanced lines having impedances of 135 ohms (approx).

The UL-TCK30G rack equipment assures:

- Regeneration of transmit and receive signals;
- Remote powering of non-serviced regeneration stations;
- Remote control and localization of faults in six simultaneously operating line routes;
- Segment service communications between a locally powered terminal or aperatured station and the non-serviced regeneration stations;
- Monitoring line routes operation damage.

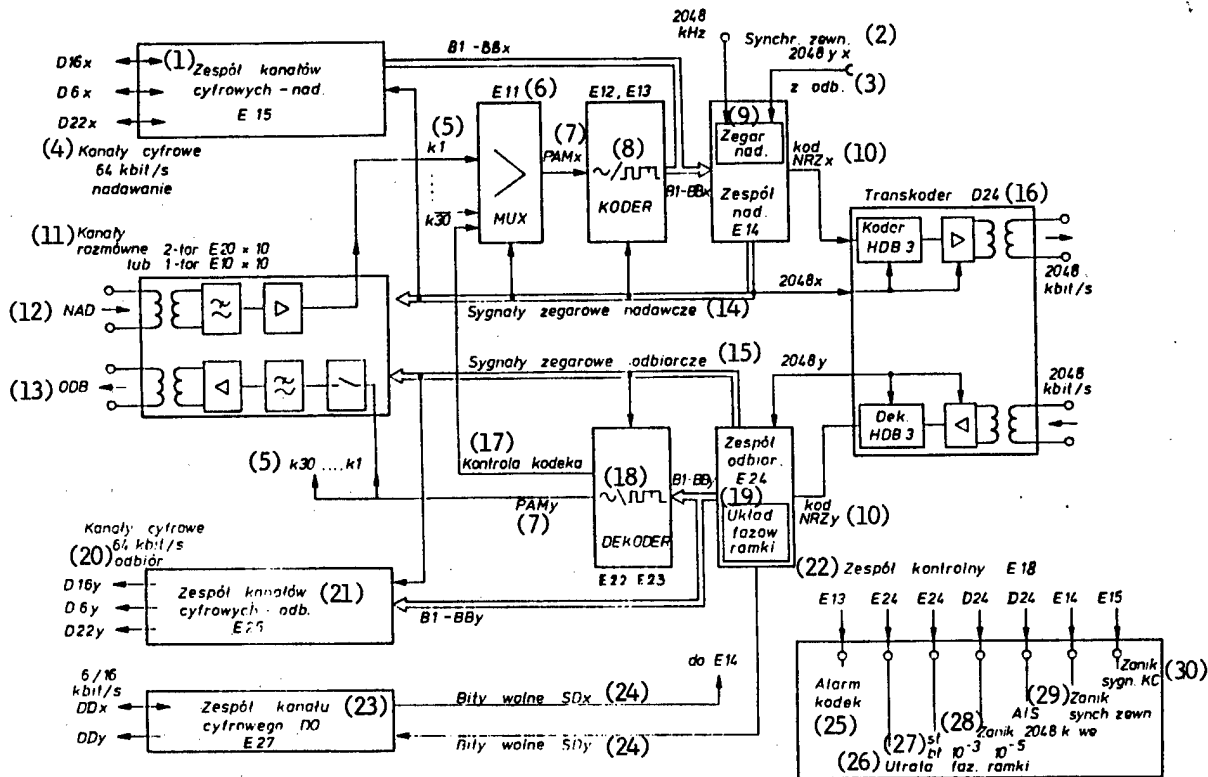

Figure 2. Block Diagram of BK2-TCK30G Multiplexer

Key: —1. Digital channels bank; transmit—2. External synchronization; 2048—3. From receive—4. Digital channels; 64 kb/s; transmit—5. Channels K1.....K30—6. E11 multiplexer—7. Pulse amplitude modulation (PAM)—8. E12, E13, E13 coder—9. Transmit clock, E14 transmit module—10. NRZ code—11. Voice channels; 2-line E20 X 10 or 1-line E10 X 10—12. Transmit—13. Receive—14. Transmit clock signals—15. Receive clock signals—16. D24 transcoder; HDB 3 coder; HDB 3 decoder—17. Codec control—18. E22, E23 decoder—19. E24 receive module; frame phase circuit—20. Digital channels; 64 kb/s; receive—21. E25 digital channels bank; receive—22. E18 control module—23. E27; D0 digital channel module—24. Free bits—25. Codec alarm—26. Frame phase loss—27. [bit] error rate indicator—28. Loss—29. External synchronization loss—30. Digital channels signal loss

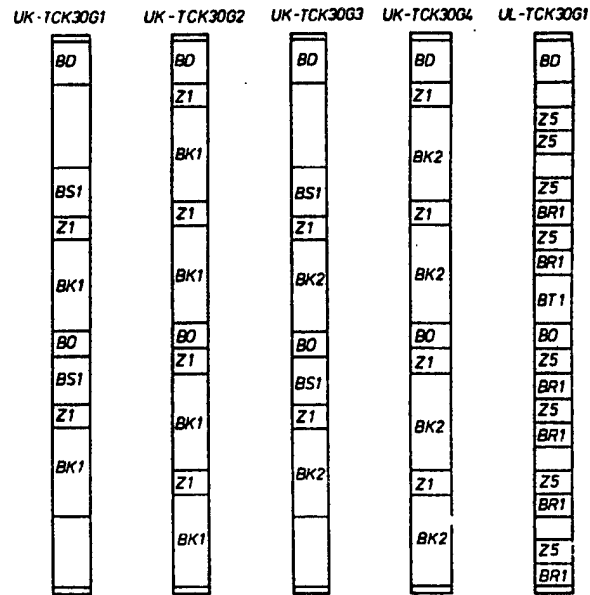

Figure 3. Frame Types for TCK30G System

Key: —1. Lead-in block—2. Signaling block—3. Multiplexer block BK1—4. Translation unknown—5. Multiplexer block BK2—6. Regeneration block

22161

SPRINGFIELD, VA
5285 PORT ROYAL RD
ATTN: PROCESS 103
NTIS

6
22161

This is a U.S. Government publication. Its contents in no way represent the policies, views, or attitudes of the U.S. Government. Users of this publication may cite FBIS or JPRS provided they do so in a manner clearly identifying them as the secondary source.

Foreign Broadcast Information Service (FBIS) and Joint Publications Research Service (JPRS) publications contain political, military, economic, environmental, and sociological news, commentary, and other information, as well as scientific and technical data and reports. All information has been obtained from foreign radio and television broadcasts, news agency transmissions, newspapers, books, and periodicals. Items generally are processed from the first or best available sources. It should not be inferred that they have been disseminated only in the medium, in the language, or to the area indicated. Items from foreign language sources are translated; those from English-language sources are transcribed. Except for excluding certain diacritics, FBIS renders personal names and place-names in accordance with the romanization systems approved for U.S. Government publications by the U.S. Board of Geographic Names.

Headlines, editorial reports, and material enclosed in brackets [] are supplied by FBIS/JPRS. Processing indicators such as [Text] or [Excerpts] in the first line of each item indicate how the information was processed from the original. Unfamiliar names rendered phonetically are enclosed in parentheses. Words or names preceded by a question mark and enclosed in parentheses were not clear from the original source but have been supplied as appropriate to the context. Other unattributed parenthetical notes within the body of an item originate with the source. Times within items are as given by the source. Passages in boldface or italics are as published.

SUBSCRIPTION/PROCUREMENT INFORMATION

The FBIS DAILY REPORT contains current news and information and is published Monday through Friday in eight volumes: China, East Europe, Soviet Union, East Asia, Near East & South Asia, Sub-Saharan Africa, Latin America, and West Europe. Supplements to the DAILY REPORTs may also be available periodically and will be distributed to regular DAILY REPORT subscribers. JPRS publications, which include approximately 50 regional, worldwide, and topical reports, generally contain less time-sensitive information and are published periodically.

Current DAILY REPORTs and JPRS publications are listed in *Government Reports Announcements* issued semimonthly by the National Technical Information Service (NTIS), 5285 Port Royal Road, Springfield, Virginia 22161 and the *Monthly Catalog of U.S. Government Publications* issued by the Superintendent of Documents, U.S. Government Printing Office, Washington, D.C. 20402.

The public may subscribe to either hardcover or microfiche versions of the DAILY REPORTs and JPRS publications through NTIS at the above address or by calling (703) 487-4630. Subscription rates will be

provided by NTIS upon request. Subscriptions are available outside the United States from NTIS or appointed foreign dealers. New subscribers should expect a 30-day delay in receipt of the first issue.

U.S. Government offices may obtain subscriptions to the DAILY REPORTs or JPRS publications (hardcover or microfiche) at no charge through their sponsoring organizations. For additional information or assistance, call FBIS, (202) 338-6735, or write to P.O. Box 2604, Washington, D.C. 20013. Department of Defense consumers are required to submit requests through appropriate command validation channels to DIA, RTS-2C, Washington, D.C. 20301. (Telephone: (202) 373-3771, Autovon: 243-3771.)

Back issues or single copies of the DAILY REPORTs and JPRS publications are not available. Both the DAILY REPORTs and the JPRS publications are on file for public reference at the Library of Congress and at many Federal Depository Libraries. Reference copies may also be seen at many public and university libraries throughout the United States.