



**US Army Corps  
of Engineers**

Construction Engineering  
Research Laboratories

USACERL Technical Report 98/20  
December 1997

# CONSTRUCTION PRODUCTIVITY ADVANCEMENT RESEARCH (CPAR) PROGRAM

## **Development of the Neptune On-Stream Robotic Inspection System for Above-Ground Storage Tanks**

by

Robert A. Weber, Tagore Sommers,  
Karl Schmidt, and Hagen Schempf

Approved for public release; distribution is unlimited.

19980126 093

DTIC QUALITY INSPECTED 2

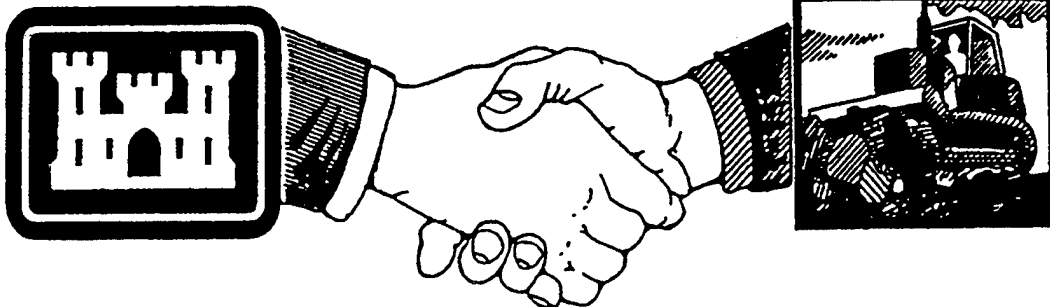

*A Corps/Industry Partnership To Advance  
Construction Productivity and Reduce Costs*

The contents of this report are not to be used for advertising, publication, or promotional purposes. Citation of trade names does not constitute an official endorsement or approval of the use of such commercial products. The findings of this report are not to be construed as an official Department of the Army position, unless so designated by other authorized documents.

***DESTROY THIS REPORT WHEN IT IS NO LONGER NEEDED***

***DO NOT RETURN IT TO THE ORIGINATOR***

# REPORT DOCUMENTATION PAGE

Form Approved  
OMB No. 0704-0188

Public reporting burden for this collection of information is estimated to average 1 hour per response, including the time for reviewing instructions, searching existing data sources, gathering and maintaining the data needed, and completing and reviewing the collection of information. Send comments regarding this burden estimate or any other aspect of this collection of information, including suggestions for reducing this burden, to Washington Headquarters Services, Directorate for Information Operations and Reports, 1215 Jefferson Davis Highway, Suite 1204, Arlington, VA 22202-4302, and to the Office of Management and Budget, Paperwork Reduction Project (0704-0188), Washington, DC 20503.

1. AGENCY USE ONLY (Leave Blank)		2. REPORT DATE December 1997	3. REPORT TYPE AND DATES COVERED Final	
4. TITLE AND SUBTITLE Development of the Neptune On-Stream Robotic Inspection System for Above-Ground Storage Tanks			5. FUNDING NUMBERS CPAR 2L2	
6. AUTHOR(S) Robert A. Weber, Tagore Sommers, Karl Schmidt, and Hagen Schempf				
7. PERFORMING ORGANIZATION NAME(S) AND ADDRESS(ES) U.S. Army Construction Engineering Research Laboratories (USACERL) P.O. Box 9005 Champaign, IL 61826-9005			8. PERFORMING ORGANIZATION REPORT NUMBER  TR 98/20	
9. SPONSORING / MONITORING AGENCY NAME(S) AND ADDRESS(ES) Headquarters, U.S. Army Corps of Engineers ATTN: CECW-E 20 Massachusetts Ave. NW Washington, DC 20314-1000			10. SPONSORING / MONITORING AGENCY REPORT NUMBER	
11. SUPPLEMENTARY NOTES Copies are available from the National Technical Information Service, 5285 Port Royal Road, Springfield, VA 22161.				
12a. DISTRIBUTION / AVAILABILITY STATEMENT  Approved for public release; distribution is unlimited.			12b. DISTRIBUTION CODE	
13. ABSTRACT (Maximum 200 words)  Owners of petroleum storage tanks are required by the Environmental Protection Agency (EPA) to conduct inspections that conform to American Petroleum Institute (API) practices. These API recommended practices specify that inspections be conducted every 5 years to make sure storage tanks are not leaking. Compliance with these requirements is essential, but it is especially costly and timeconsuming for the operators of industrialscale tank farms.  The U.S. Army Construction Engineering Research Laboratories (USACERL) and Raytheon Engineers and Constructors of Lyndhurst, NJ, worked in partnership to develop a remotely operated robotic system capable of onstream inspection of submerged infrastructure components for corrosion and other damage. The prototype system comprised a dualtracked platform mounted with ultrasonic and visual inspection technology. The unit was to be selfcontained and explosionproof according to applicable National Fire Protection Association Class 1, Division 1 standards.  The prototype system could not pass applicable safety tests. Connectors were designed incorrectly for service in explosive environments and unprotected wires on the outside of the robot were out of compliance with applicable guidance. Other mechanical trouble with robot components are noted. However, it is concluded that the prototype system demonstrated the viability of the concept of onstream testing of storage tanks and water structures.				
14. SUBJECT TERMS Construction Productivity Advancement Res (CPAR) Civil Works storage tanks			inspection corrosion robotics	15. NUMBER OF PAGES 42
				16. PRICE CODE
17. SECURITY CLASSIFICATION OF REPORT Unclassified	18. SECURITY CLASSIFICATION OF THIS PAGE Unclassified	19. SECURITY CLASSIFICATION OF ABSTRACT Unclassified	20. LIMITATION OF ABSTRACT SAR	

## Foreword

This study was conducted for Headquarters, U.S. Army Corps of Engineers under "Construction Productivity Advancement Research (CPAR) Work Unit 2L2, "Robotic Inspection System for Buried and Submerged Structures." The Technical Monitors were D. Dressler (CECW-ED), M.K. Lee (CECW-EG), and D. Pommer (CECW-OC).

The work was performed by the Materials Science and Technology Division (FL-M) of the Facilities Technology Laboratory (FL), U.S. Army Construction Engineering Research Laboratories (USACERL). The CPAR Industry Partner in this research was Raytheon Engineers and Constructors, Lyndhurst, NJ. The USACERL Principal Investigator was Robert A. Weber. The Principal Investigators for Raytheon were Tagore Sommers and Karl Schmidt. It is noted that the original CPAR Industry Partner was Ebasco Services, Inc., of Lyndhurst, NJ. During the work Ebasco was acquired by Raytheon, who assumed responsibility for Ebasco's CPAR work on Neptune. Dr. Ilker R. Adiguzel is Acting Chief, CECER-FL-M, and L. Michael Golish is Acting Operations Chief, CECER-FL. The USACERL technical editor was Gordon L. Cohen, Technical Information Team.

COL James A. Walter is the Commander of USACERL, and Dr. Michael J. O'Connor is the Director.

# Contents

<b>SF 298</b> .....	1
<b>Foreword</b> .....	2
<b>List of Figures</b> .....	4
<b>1 Introduction</b> .....	7
Background .....	7
Objective .....	9
Approach .....	9
<b>2 Concept, Design Requirements, and Inspection Methodology</b> .....	11
Change in Project Scope .....	11
System Concept and Basic Capabilities .....	12
Operational Safety Requirements .....	12
System Description .....	14
Inspection System Methodology .....	19
<b>3 Proof-of-Concept Tests</b> .....	29
Carnegie Mellon Acceptance Test .....	29
Raytheon Proof-of-Concept Tests .....	29
Limitations of the Prototype Crawler .....	30
Lessons Learned on Mobile Platform Engineering and Safety .....	31
<b>4 Conclusions, Recommendations, and Commercialization</b> .....	37
Conclusions .....	37
Recommendations .....	38
Commercialization .....	38
<b>References</b> .....	39
<b>Distribution</b>	

# List of Figures

## Figures

1	System overview .....	21
2	Schematic of crawler .....	21
3	Drive motor and gearbox assembly .....	22
4	Schematic of switchable magnetic control .....	22
5	Camera assembly .....	23
6	Ultrasonic sensor trolley .....	23
7	Schematic of DataRocket communications subsystem .....	24
8	Acoustic navigation transponder .....	24
9	Inside view of Neptune deployment module .....	25
10	Illustration of Neptune control console .....	25
11	Portable control console for Neptune .....	27
12	Thickness map from trial run Neptune UT system mounted on Raytheon's Argus robot .....	27
13	Crawler hanging by tether during acceptance test at CMU .....	32
14	Crawler beginning entry procedure during CMU acceptance testing .....	33
15	Crawler completing transition to floor during CMU acceptance testing .....	33
16	Crawler resting on test plate used for CMU acceptance tests .....	34
17	Close-up of the front .....	34

---

18	Close-up of rear showing UT sleds and tether connection point .....	35
19	Contour map of Wood's Hole test data collected by Neptune UT system mounted on Raytheon's Argus robot .....	35

Preceding Page <sup>5/</sup>Blank

# 1 Introduction

## Background

The Environmental Protection Agency (EPA) requires petroleum storage tank owners to provide documentation that their tanks do not leak (40 CFR 280). Tank owners are required to conduct inspections that conform to American Petroleum Institute (API) practices defined in API 653 (API 1992). These API-recommended practices specify that inspections be conducted every 5 years to ensure that storage tanks are not releasing their contents into the environment. Compliance with these requirements is essential, but it can be especially costly and time-consuming for the operators of industrial-scale tank farms.

The U.S. Army Construction Engineering Research Laboratories (USACERL) originally proposed to coordinate the development of an in-tank mobile robot to inspect both above-ground and underground storage tanks (ASTs and USTs, respectively) under the U.S. Army Corps of Engineers Construction Productivity Advancement Research (CPAR) program. A remote camera for visual inspections and add-on sensors for wall- and floor-corrosion measurements were included in the concept for the robot system. The system was to be a self-contained portable unit that would be mated to the storage tank. The small, tethered robot would be deployed with dual magnetic tracks, a camera and lights, a navigation system, ultrasonic testing (UT) sensors, and any other sensing probes that might be useful for condition assessment.

The robot would employ explosion-proof electrical and mechanical components to allow safe, effective inspection of the inside surface whether the tank was full of fuel (i.e., on-stream inspection) or empty. All applicable standards of the National Electric Code (NEC), the National Fire Protection Association (NFPA Class I, Div. I standards), and the American Petroleum Institute (API) would be rigorously observed to produce a robotic system rated as explosion-proof for operation in full immersion in fuel-grade petroleum products.

Access to the tank was to be achieved through the use of a reconfigurable track design, allowing the robot to fit through large tank openings (20 in. outside diameter [OD]) using a parallel track configuration, and through very small tank

openings (4 in. OD) via an in-line track configuration. The magnetic force of the tracks would fully account for the robot's weight and keep it attached to the inside tank surfaces.

The internal condition of the tank would be surveyed using a simple series of planned passes. An accurate and repeatable corrosion survey of a tank over time would be made possible through the use of a simple, accurate commercial acoustic positioning system. This system would use sound transmission and triangulation through the tank walls to guide the robot over the same surfaces inspection after inspection.

It was envisioned that the robot could be operated by one person. The unit's small size and flexible configuration would make it easy to transport and usable on a wide variety of tank sizes and shapes. Computer control and a graphical interface would be included to display robot position and generate a picture of tank corrosion status.

For reasons described in Chapter 2 of this report, the focus of the CPAR project was narrowed to address on-stream inspection of above-ground storage tanks. ASTs have inherent design characteristics that promote excessive corrosion of the flat tank floor. Single-shell steel ASTs typically are built within a recessed, membraned, and diked area in order to contain all spillage in case of a rupture; this containment feature also can trap rainwater and runoff, creating favorable conditions for steel corrosion on the outside of the tank bottom. The most common AST failure modes are (1) stress corrosion cracking along weld seams of the steel plates, especially in the corners where walls meet the floor, and (2) pitting corrosion that leads to section loss. Most tank welds and surfaces that are exposed to the elements (i.e., the external walls and dome) can be inspected from the outside. However, the entire external surface of the tank floor is inaccessible.

Corrosion inspection of the tank floor must be conducted from inside the tank, as does inspection for any internal corrosion affecting the walls and dome. Before a human inspector can conduct an internal inspection with hand-held instruments the AST must be emptied, cleaned, and vented. This inspection approach takes a tank out of commission for at least 2 weeks, resulting in a substantial nonproductive costs for the tank owner. The cost of following the practices recommended under API 653 is largely driven by (1) removal of the tank system from service, (2) removal of sludge, and (3) gaining of access to insulated or buried pipes servicing the tank. Additionally, productivity costs also are felt due to lost operational time while the system is *off-stream* for cleaning and inspection. Taken together, the costs and productivity losses associated with off-stream tank inspection can amount to a great economic burden for the operators of large tank inventories such as the U.S.

Army and private-sector industrial owners. Therefore, a technology-based solution for internal on-stream AST inspection would be of great value to large-scale AST owners and operators.

## Objective

The objective of this work was to develop a remotely operated robotic, in-situ condition assessment system for buried or submerged infrastructure components such as underground storage tanks (USTs), above-ground storage tank (AST) bottoms, lock and dam gates, and hydroelectric system components (penstocks). This technology will be applicable to other metallic structures with relatively smooth surfaces.

## Approach

The development of a flexible, robot-based system for *in situ* inspection of buried or submerged infrastructure components was based on modular components that enable reconfiguration of the system to tailor it to specific condition-assessment applications. This approach also enables continuous upgrades of the Neptune system without requiring the design or construction of a new device. The sensor-transport mechanism incorporated both a crawler and an underwater vehicle.

The specific approach specified in the CPAR-CRDA was as follows:

- 1. Develop explosion-proofing standards and technology for the system.** This task will consist of the development of explosion-proof standards for the underwater vehicle and crawler mechanisms. These will initially be applied to the underwater vehicle, which is the property of Ebasco, and the communications tether. Ebasco will have primary responsibility for this effort.
- 2. Crawler mechanism development.** This task will involve the development of the crawler mechanism. The task will produce track mechanisms, the telemetry and control component, the crawler vehicle housing, and the video camera component. USACERL will have primary responsibility for this effort.
- 3. Sensor module development.** This task consists of the development of explosion-proofed ultrasonic sensors and appropriate processing software. This system component will be usable on both the underwater vehicle and the tracked crawler. Ebasco will have primary responsibility for this task.
- 4. Enhanced positioning component and data processing/display components.** This task will consist of software and hardware improvements to

positioning technology and data processing and display technology, already owned by Ebasco, to improve performance and allow them to be used with both the underwater vehicle and the crawler as part of the overall condition-assessment system. Ebasco will have primary responsibility for this task.

5. **System integration.** This task consists of the integration of the two mechanisms (underwater vehicle and crawler), the sensor component, the telemetry component, the positioning component, and the control component into a functional system that can be used to collect data. This task must be worked throughout the project to ensure that each separate component development will successfully integrate in the final system. It will also include laboratory tests of the final system. Ebasco will have primary responsibility for this task.
6. **System demonstration.** This task consists of a demonstration of the system at a to-be-determined Army site to show system capabilities and validate safety and environmental considerations. USACERL and Ebasco will share responsibility for this task. Every effort will be made to make this demonstration an actual field condition-assessment to fill a valid customer inspection requirement. USACERL will be responsible for coordinating access to the demonstration site, including appropriate clearances. Ebasco will be responsible for operations on site.
7. **Final report.** A technical report on the results of the project will be prepared and disseminated to the field.

This approach was in general followed through project completion. Deviations from the specified approach are explained where appropriate in the text.

It should be noted that the CPAR partner specified in the original CPAR Cooperative Research and Development Agreement (CPAR-CRDA)—Ebasco, Inc., of Lyndhurst, NJ—was during the course of this project acquired by Raytheon Engineers and Constructors, also of Lyndhurst, NJ. At the time of the acquisition, Raytheon assumed Ebasco's responsibilities for Neptune under the CPAR-CRDA.

## 2 Concept, Design Requirements, and Inspection Methodology

### Change in Project Scope

When the CPAR-CRDA was in place and the project begun, the design requirements were investigated and data were collected about the various tank styles and sizes used for above-ground and below-ground storage. It was found that approximately 90 percent of the USTs in the data set had access hole diameters of 4 in. All ASTs in the data set had access hole diameters of 20 in. or larger. The technology required to miniaturize Neptune for entry into a 4 in. opening was determined to be well beyond the assets assigned to the CPAR-CRDA. Furthermore, Raytheon's principal interest in acquiring the Neptune technology was to help AST owners and operators to meet the environmental requirements stated in 40 CFR 280. Consequently, the partners decided to proceed with a robot sized for access through a 20 in. port. This change in robot size did not preclude investigation of Neptune applications for lock and dam gates, pen stocks, etc., as intended in the original project objective. Raytheon was willing to test Neptune on such structures, but no suitable demonstration site was found during the field-testing phase. Therefore, the focus of the work remained on AST applications.

It should be noted that later, in work sponsored by the Small Business Innovative Research (SBIR) program and the Environmental Security Technology Certification Program (ESTCP), a robot called Fury was designed and built for entry into 4 in. access openings. The cost to develop a prototype robot was \$750,000 (USACERL SBIR work units MV3 [1993], MV4 [1994], and MV5 [1995]). The follow-on ESTCP work units (XZ5, 1995; XZ6, 1996) required another \$920,000 for further development and technology demonstration through 1996. These cost figures confirm that Neptune could not have been adequately miniaturized for UST access within the budget allocated through the CPAR-CRDA.

## System Concept and Basic Capabilities

The Neptune system was designed to provide the tank inspection data quality and statistically representative data density required by API 653 (1992) without taking storage tanks off-stream. A number of remotely operated devices are commercially available for inspection or cleanup of pipes (Foster-Miller 1992; EMCO Intertest 1992) and sewer lines (Brockelman 1993; RICO EAB 1993), but none has the range of capabilities designed into the Neptune concept:

- ability to internally inspect storage tanks without emptying and venting them
- multiple sensing modes (i.e., visual and ultrasonic testing [UT])
- full integration of mobile platform, microprocessors, sensors, and telemetry
- industry safety rating for full immersion in explosive petrochemicals.

One related system has been patented (Bughman and Jones 1988), but it requires emptying the tank before use and relies on human operators inside the tank for cleanup. Therefore, this system offers no advantages over standard methods in terms of avoiding downtime or improving human safety.

The Neptune system is designed to provide a:

- visual record of each weld seam in the tank using an onboard color camera
- thickness-contour map of the tank bottom using a UT plate thickness measurement sensor array.

The prototype system was intended for use in flammable liquids such as kerosene, gasoline, jet fuel, and other light crude petroleum distillates stored in closed tanks and tanks with external floating roofs.

## Operational Safety Requirements

The greatest development challenges were to design a system:

- able to fit through 20–36 in. diameter AST openings
- incorporating all basic capabilities described in the CPAR-CRDA objective
- able to earn industry certification for safe operation in highly flammable environments.

Based on classification system and requirements defined by the *Flammable and Combustible Liquids Code* (National Fire Protection Association [NFPA] 1990) and

the *National Electric Code* (NFPA 1993), Neptune would need to be certified for safe operation in NFPA Class I, Division 1, Group D conditions. This classification covers (1) deployment in flammable and combustible gas or fume environments, (2) operation in areas where the flammable and combustible product is present during normal operating conditions, and (3) the type of material present in such operating environments, typically rated by its *ease of explosion* and expressed in terms of its auto-ignition temperature (AIT).

Four basic safety approaches are specified to ensure that a system can operate in Class I environments without causing an explosion:

1. intrinsic safety of equipment
2. purging
3. pressurization
4. explosion-proofing.

A system may be termed *intrinsically safe* if it operates under such low energy that it could under no circumstances ignite any gaseous mixture. A system that uses too much energy to be considered intrinsically safe can be housed in a properly safeguarded enclosure and continuously purged with fresh air or inert gas at a specified pressure and flow rate; such a system may be termed a *purged system*. In cases where a purged system is not feasible, an alternative approach is to pressurize all system enclosures to a level above ambient and monitor continuously; such a system may be termed a *pressurized system*. A common safety approach for fixed installations or large moving equipment is to design enclosures that can withstand an internal explosion without igniting flammable gases in the surrounding environment; such a system may be considered *explosion-proof*.

Neptune could not be engineered to be intrinsically safe because its motors and onboard systems required about 500 W of electricity—far greater than the energy necessary to ignite flammable fumes under Class I conditions. Pneumatics or hydraulics could not be substituted for electricity as the power source for locomotion because they would have required bulky, cumbersome support components both onboard the crawler and outside the AST. The purging approach also was ruled out because it would have required an unwieldy system of air supply and return lines plus a large, heavy tether management system atop the tank. Explosion-proofing was ruled out for similar reasons: the approach would have produced a bulky, heavy system that could not meet Neptune's conceptual size, weight, and mobility requirements. Therefore, the most viable safety approach for Neptune was pressurization.

By providing a pressure differential with respect to the outside, the electronics and motor/sensor systems can operate under the required power levels inside the enclosures. Using redundant temperature and pressure sensors in addition to hardware and software safety backups, Neptune was designed to address all regulations applicable to NFPA Class 1, Division 1, Group D operating environments.

## System Description

### *Overview*

The Neptune system consists of six basic elements, four of which are visible in Figure 1\*:

1. the robot crawler with its magnetically switchable tracks
2. the onboard vision and UT sensors
3. the onboard control and telemetry system (not visible)
4. the onboard in-tank navigation system (not visible)
5. the deployment system atop the tank
6. the remote operator console and the display and control software.

Under the CPAR-CRDA, development of the navigation and UT sensor system was the responsibility of Raytheon, the CPAR Partner. The Neptune crawler prototype was designed, fabricated, and tested by the Robotics Center at Carnegie Mellon University under contract to USACERL.

Each subsystem is discussed in the sections that follow.

### *Deployment and Operation*

The robot crawler, as deployed from its pod atop the AST, navigates on the tank floor and walls using a tank-internal acoustic positioning system. An onboard camera and UT sensors provide visual feedback and steel plate thickness measurements to the remote operator. The system can work in tele-operated mode or computer-controlled closed-loop mode, both of which can be monitored using the synthesized bird's-eye view generated on the host computer's graphics display using a commercial 3D rendering package.

---

\* Figures are presented at the end of the chapter in which they are first discussed.

Neptune is designed to work in tele-operated mode using a joystick console during deployment and retrieval. During the scanning phase on the tank floor and walls, the operator uses a mouse to pick a four-sided polygon surface for the robot to scan. The trajectory-planning software lays out the grid pattern and sends data for the desired trajectory to the execution module, then brings the robot to the starting position and surveys crawler position throughout the scan. The crawler is controlled using proportional integral differential (PID) control for headings to keep the crawler on the desired path. The treads controlled in simple velocity PID control mode.

The 3D graphics display is used to supervise the crawler's scanning operation. Embedded in the graphics software are routines that check for potential collisions or chafing of the tether along known tank obstacles (such as columns and pipes). A simple n-dimensional quasi-static discrete chain model is used for the tether, and collision checking is performed along its arc-length. Tether-payout is controlled using a closed-loop PID controller based on the known crawler position, a catenary tether model, and a comparison to tether length payed out. The operator is always able to override the closed-loop control for the crawler and the winch at any time in case of emergency or to work in tele-operated mode.

### ***Robot Crawler***

The robot crawler shown in Figure 2 comprises a set of anodized aluminum pressure-tight enclosures to house the controller, power and telemetry electronics, the UT system electronics, the camera and light system, and the navigation transponder subsystems. The track-driven locomotors are separate enclosures housing motors and transmissions, connected to the rest of the system via a steel-braided Teflon\* -coated hose and connectors. The entire system can be pressurized, and thus all enclosures can be monitored by the computer and a single redundant sensing system. All interconnection wiring is run through the back end-plate that holds all enclosures together. The tether system (umbilical) consists of a custom electro-optical cable connected to the robot with a swivel connection to allow the robot to make sharp upward transitions without scuffing or kinking the cable. The electro-optical umbilical consists of a single-mode light fiber, redundant power conductor pairs, and drains, all encased in impermeable filler and surrounded by braided Kevlar\*\* and a tough abrasion-resistant polymer coating. Custom electro-optical connectors on either end of the cable ensure easy maintenance and assembly in the field.

---

\* Teflon is a registered trademark of DuPont Co., Wilmington, DE.

\*\* Kevlar is a registered trademark of DuPont de Nemours, E.I., & Co., Inc., Wilmington, DE.

The track locomotors consist of an internal inline motor and planetary gear train driving a pair of dual-output bevel gear shafts, which in turn drive the sprockets that engage the tread. Figure 3 shows a photograph of the completed gearbox and motor subsystem before it was placed in the Neptune body.

Incorporated into the gearbox is a bi-metallic, clutch-actuated inline concentric drive shaft that engages and disengages a permanent-magnet circuit. The principle, depicted in Figure 4, is similar to that used in magnetic measurement stands on milling beds. The bimetallic shaft is turned in order to close and open the magnetic circuit. The resulting magnetic flux can bypass the magnet (no magnetic attraction) or flow through the resting surface (magnetic holding effect). By properly specifying the magnet shape, pole area, and tread piece cross-section, the necessary holding forces can be generated to fully support the crawler on vertical and inverted surfaces. When activated, this circuit magnetizes the crawler's bi-metallic tread, enabling the crawler to attach to the AST's steel plates. When the circuit is switched off, the treads are demagnetized to allow removal of the crawler from the steel plate. This switchable magnetic circuit also was intended to enhance crawler maneuverability.

An auxiliary set of permanent-magnet treads allows the crawler to make the transition from horizontal to vertical surfaces. This auxiliary track unit is passively hinged to the crawler and the treads are mechanically slaved to the locomotor drive sprockets. These auxiliary treads are designed to promote a successful transition despite surface conditions, varying friction properties, and track shapes. Note that permanent magnets were used only on alternative tread elements because the magnets tend to attract all magnetic material they drive over, especially oxides in the form of corrosion flakes. The buildup of such debris on the crawler treads would reduce their magnetic holding capacity.

### **Sensors**

The sensors used on the crawler consist in part of a miniature color charge-coupled device (CCD) camera aided by a low-temperature set of tuned halogen lights or light-emitting diodes (LEDs) to illuminate the path in front of the vehicle to allow the tele-operated tracking of weld seams (Figure 5). The onboard measurement system is a Cygnus Instruments multiple-echo thickness gauge. This device is configured for operation on a remotely operated vehicle (ROV), making it suitable for use as a proof-of-concept inspection system for Neptune. However, because the Cygnus system does not allow the operator to view and save the full UT signal waveform, and because the system is not easily adapted to increase the number of transducers for greater coverage, the system was not intended for use on Neptune

past the proof-of-concept stage. The Cygnus system was removed following proof-of-concept testing and will not be used in the next generation of crawlers. The sensors were mounted to the rear of the vehicle on a towed self-leveling trolley (Figure 6). Data and visual feedback signals are continuously logged and stored for later retrieval, analysis, and reporting.

### ***Electronics and Telemetry***

The telemetry system, called "DataRocket," is a custom design developed at the Field Robotics Center (FRC), Carnegie Mellon University. A highly miniaturized dual-wavelength, single-mode fiber system was designed using commercially available components, and integrated on a custom microcomputer board designed to fit inside the crawler enclosures. The DataRocket system is characterized by a 1.4 Gbit\*/sec transmission rate, two duplex 60 MHz\*\* analog video channels, two duplex high-speed (10 MHz) serial communication channels, and multiple analog/digital input/output (I/O) channels. A simplified block diagram of the system architecture is shown in Figure 7.

The onboard controller is based on the Motorola 68HC811 8-bit microprocessor. It monitors the telemetry system and onboard sensors, and controls HP HCTL-1100 motor-controller chips for the track locomotors. Communications are executed via dual asynchronous serial lines between the crawler and an identical topside microcontroller/telemetry system. The topside microprocessor communicates with a host computer via serial link. The host computer is a high-power computing and display engine for operator display, planning, and control functions.

The entire crawler runs on a 48 VDC\*\*\* power bus generated by 300 VDC supplied through the tether. Other voltage levels needed are generated internally using DC-to-DC converters. Electrical switching for all systems is done by solid state relays. UT data and the camera's video signals are directly transferred to the topside using the two dedicated analog video channels supplied as part of the telemetry system.

### ***Navigation System***

The Physical Acoustics\*\*\*\* acoustic leak-detection system consists of a signal processing computer and an array of receivers installed on the outside tank wall. The system was modified to receive signals from and calculate the position of the

---

\* Gbit: gigabits.  
\*\* Mhz: megahertz.  
\*\*\* VDC: volts, direct current.  
\*\*\*\* Physical Acoustics Corp., P.O. Box 3135, Princeton, NJ 08543-3135.

Marquest pingers, thus providing a navigation capability within the tank. Figure 8 shows one of the transponders used in the SHARPS system. The system was baselined against a standard Marquest SHARPS acoustic positioning system in a 15 ft test tank at Woods Hole Oceanographic Institute, and navigation data were shown to be quite accurate. A full-scale test of the system was then performed at the Mobil Paulsboro Refinery in a 40 foot diameter tank. This test was also successful. (Raytheon subsequently contracted with Physical Acoustics Corp. to provide the complete navigation system for the production tank inspection system now under development.)

### ***Deployment Pod***

The deployment pod consists of an aluminum structure that is attached to the manway of a tank to hold the winch and deployment cage for the vehicle (Figure 9).

The winch system consists of a sealed and pressurized geared motor and control electronics system that drives a winch-drum and a slaved level-wind to handle the 500 ft of electro-optic umbilical. A mercury power slip-ring and an optical slip-ring allow the transfer of power and data through the rotating cable drum. The deployment cage consists of a set of linear and rotary bearing stages to control the bending radius of the electro-optic tether, which prevents any cable scuffing on the inside of the tank's manway penetration. The deployment pod is sized to hold the entire robot/winch system for transport and subsequent installation atop an AST—typically 60 ft high—using a crane. The winch drum and level-wind are monitored using an externally mounted TV camera and light system that peers through a plexiglass viewport mounted atop the deployment pod. Much design effort was dedicated to the winch system because it sets completely immersed in the vapor zone of the tank's petroleum contents. Components such as the motor and the power slip-ring were certified by Underwriters Laboratory. The pressurization scheme was designed to completely isolate the control electronics from explosive vapors.

The winch control electronics are custom-made and are also based on the Motorola 68HC811 microprocessor. The winch motor is a stepper-motor controlled in speed-mode, with absolute position gathered through a system comprising a battery-backed resolver, a speed-to-position counter, and a memory chip. Communications to and from the remote console are executed via serial cable. Typically, the commands control forward/reverse motions and desired speed. Position/velocity and system pressure and temperature are represented as feedback to the console.

### ***Control Console***

The control console consists of the host computer system, power conditioning system, video monitors, and telemetry interface system mounted into a 19 in. rack. A remote portable control console housing the robot control joystick, the kill-button, and a touch-screen display are included for remote control and display purposes. The complete system is depicted in Figure 10. The host computer is a Sun SPARC IPX microprocessor, which is used to drive the display, planning, and control portions of the software. Custom planning and control software is integrated with a commercially available three-dimensional graphics rendering package in order to synthesize a display of the robot inside the tank while plotting desired and actual trajectories. Views can be altered at will, allowing the operator to use a bird's eye view. Other information such as temperature and pressure are monitored by the system and displayed in the form of gauges and sliders. Any anomalous condition is reported to the operator so immediate remedial action can be taken when required, in cases such as shutdown or a systems check.

The remote console is used to display critical information flowing to and from the host computer in case the operator is not situated in front of the control rack (Figure 11). The post-processing and real-time display of steel-plate thicknesses are displayed on an auxiliary computer. These data can be integrated on the host computer monitor along with robot position, plate thickness contours and elevation maps, pressure sensors, and hardware and software safety backups. The system was designed to address all regulations pertaining to NFPA Class I, Division 1, Group D applications.

### **Inspection System Methodology**

The inspection requirements for Neptune were defined as follows:

- Measurement of plate thickness due to general thinning on internal and soil-side surfaces to within +/- 0.005 in.
- Measurement of pit depth for corroded areas on the soil side of the tank floor plates to within +/- 0.005 in.
- Reliable differentiation between topside and soil side corrosion.
- Reliable differentiation between general wall thinning and plate laminations.
- Measurement of remaining ligament on pits as thin as 0.005 in. originating from the soil side.
- Navigation accuracy within the tank to within +/- 6.0 in.

- A mobile sensor platform capable of traversing the tank internal surfaces without being affected by any sediments encountered.
- An integrity assessment sensor system, including ultrasonic, eddy current, and acoustic sensors carried on the mobile platform, and acoustic sensors mounted on the outside wall of the tank.
- A navigation sensor system consisting of acoustic transmitters and a pressure depth sensor mounted on the mobile platform, and an array of acoustic receivers mounted on the outside of the tank.
- A control center some distance from the tank wherein signals from the integrity assessment sensors and navigation system are processed, and from which command signals are transmitted to the mobile platform.
- A set of software programs for navigating and controlling the mobile platform and for processing, display, and recording of the integrity assessment sensor data.
- Certification of the mobile platform and integrity assessment sensors for safe operation in a Class I, Division I, Group D environment, as defined by the National Fire Protection Association Code.

The on-stream inspection methodology used by Neptune comprises six steps:

1. Perform an external acoustic (or other) leak detection test on the tank.
2. If no leaks are found, proceed with an internal examination using the leak detection receiver array as a navigation receiver array.
3. Scan the floor plates with a combined ultrasonic/eddy current array. The ultrasonic system provides wall thickness measurement and detection of soil-side pitting. The eddy current system provides topside crack detection and differentiation between soil side and topside pitting. The scan may encompass from 2 percent to 98 percent of the tank floor. In most cases scanning about 10 percent of the floor area will provide a sufficient sample for an accurate condition assessment.
4. Continuously measure and record pressure depth on the mobile platform to create an elevation map of the tank floor. The shape obtained can then be compared with API 653 guidelines on acceptable levels of floor distortion.
5. Post-process the data to remove bad data points and correlate the results of the UT and eddy current exams. This process results in a thickness map and a set of statistics. Figure 12 shows an example of a thickness map from the Raytheon proof-of-concept test reported in Chapter 3.
6. Input the statistics from the examination to an extreme value analysis to predict worst-case floor thinning. The time to the next inspection can be calculated based on the worst-case floor thinning and the estimated floor corrosion rate.

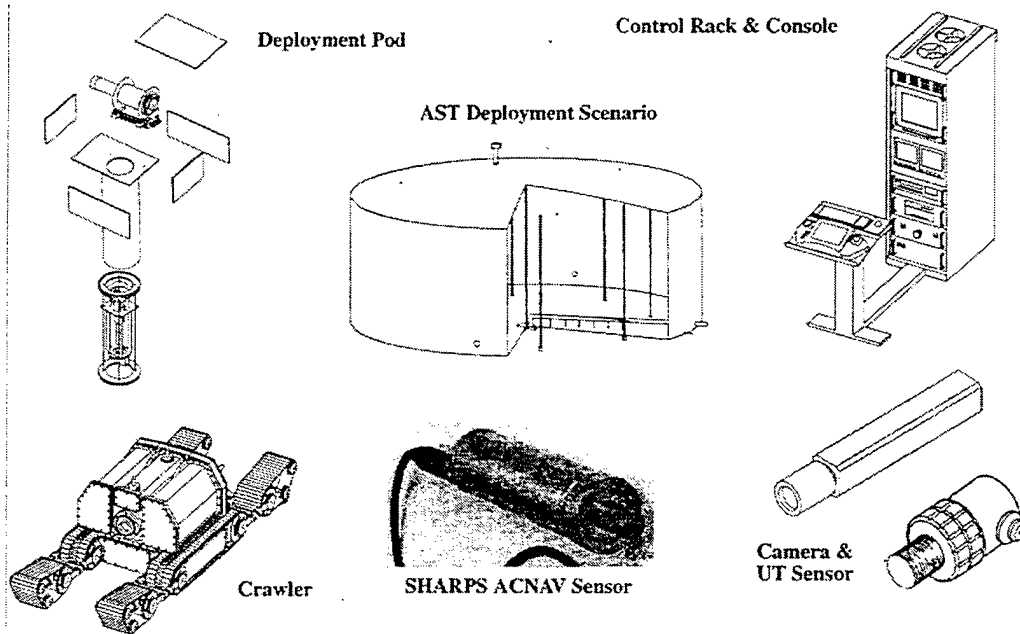

Figure 1. System overview.

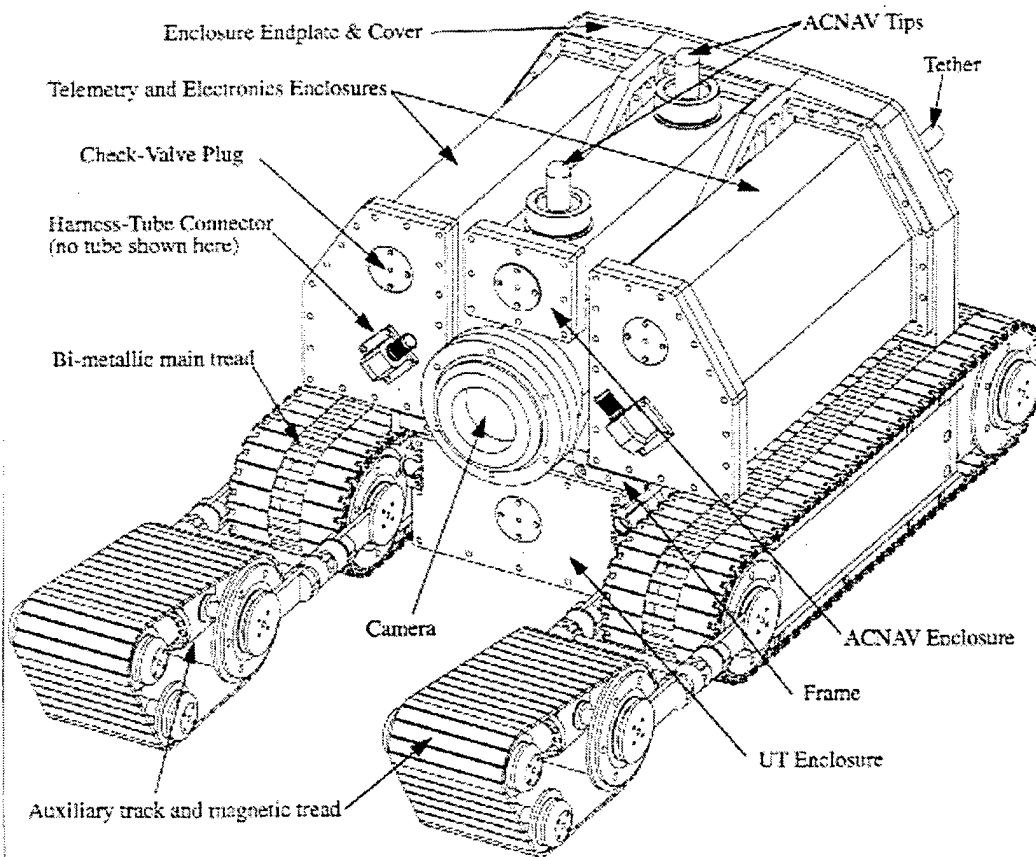

Figure 2. Schematic of crawler.

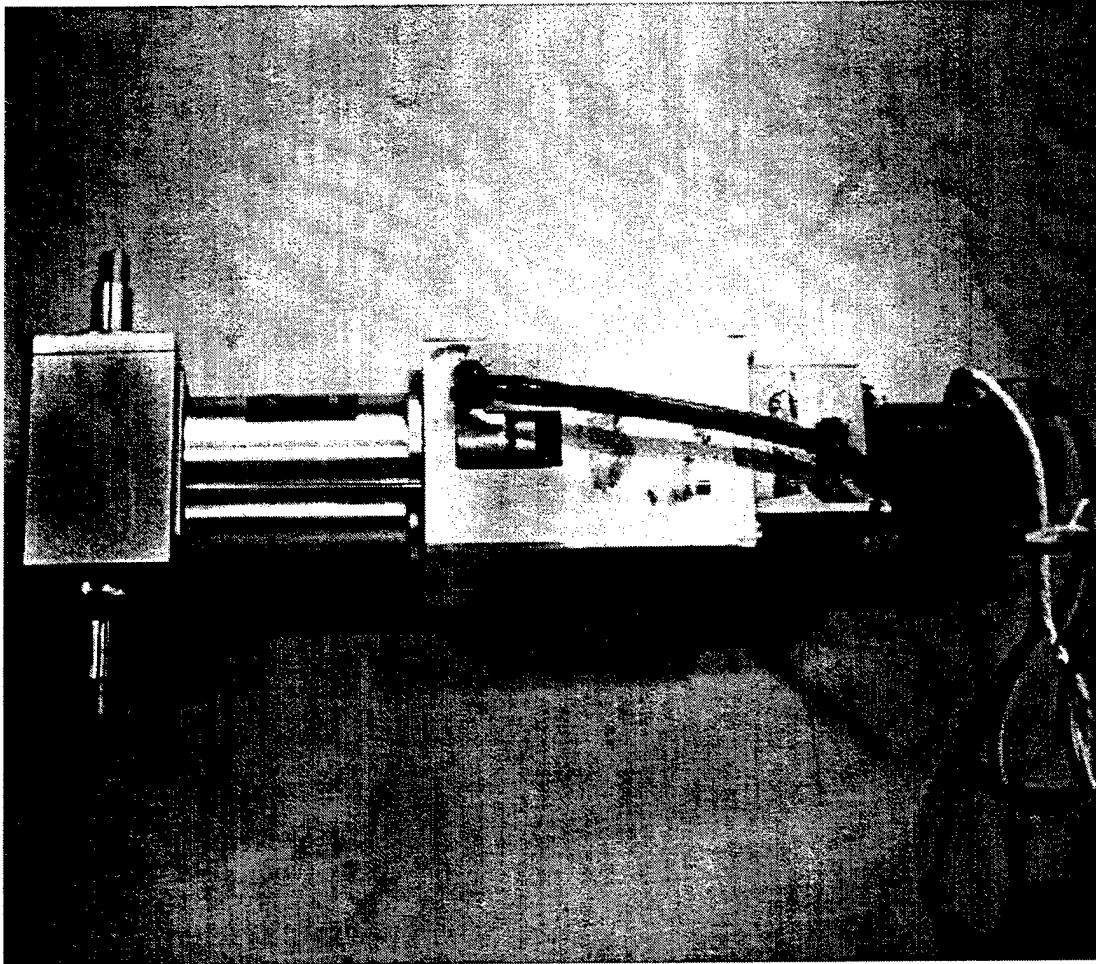

Figure 3. Drive motor and gearbox assembly.

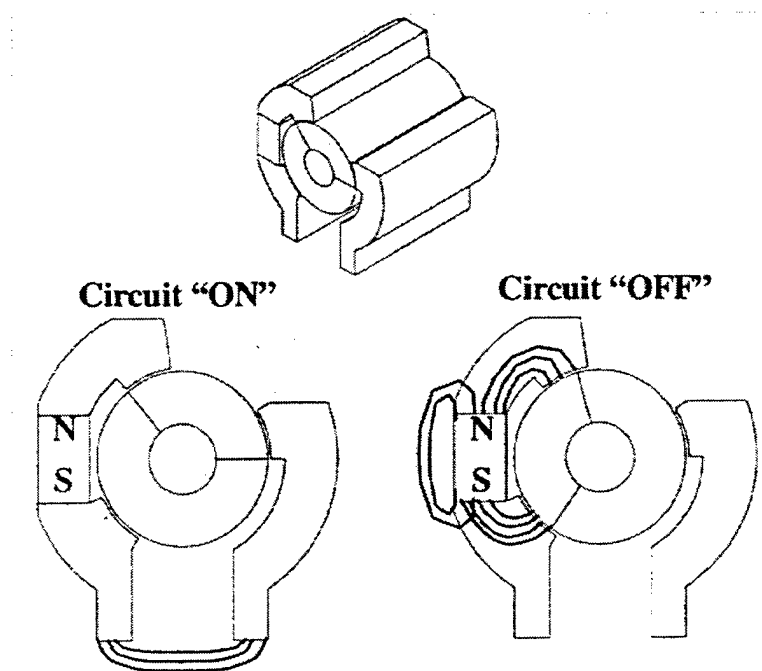

Figure 4. Schematic of switchable magnetic control.



Figure 5. Camera assembly.

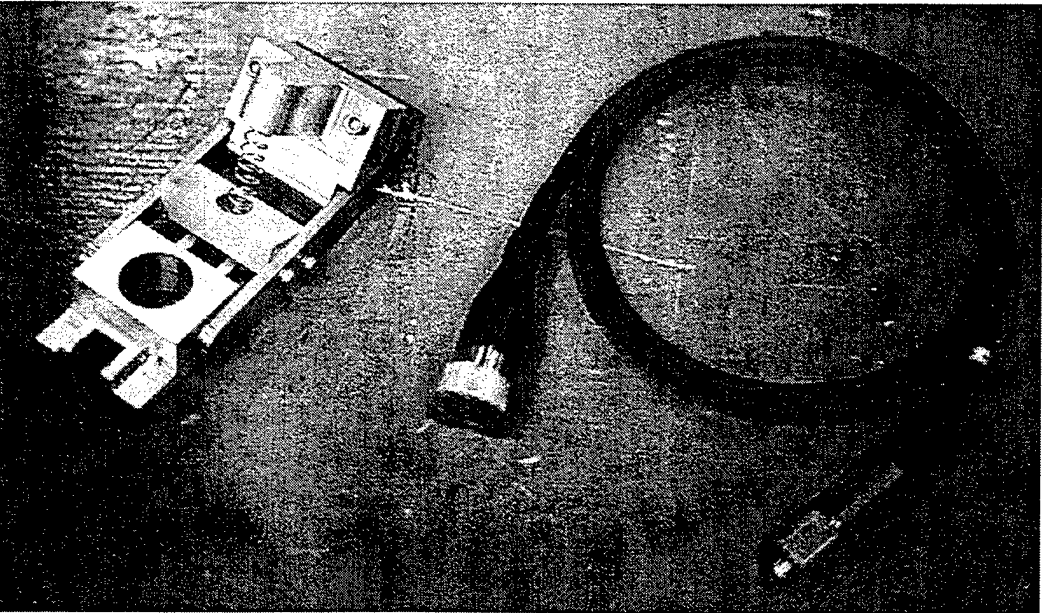

Figure 6. Ultrasonic sensor trolley.

# DataRocket II - System Diagram

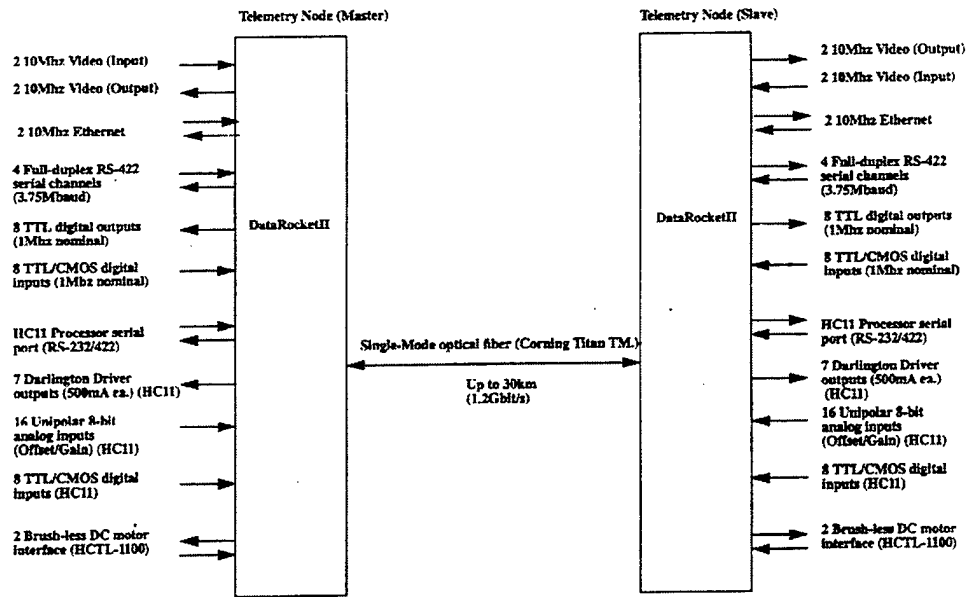

Figure 7. Schematic of DataRocket communications subsystem.

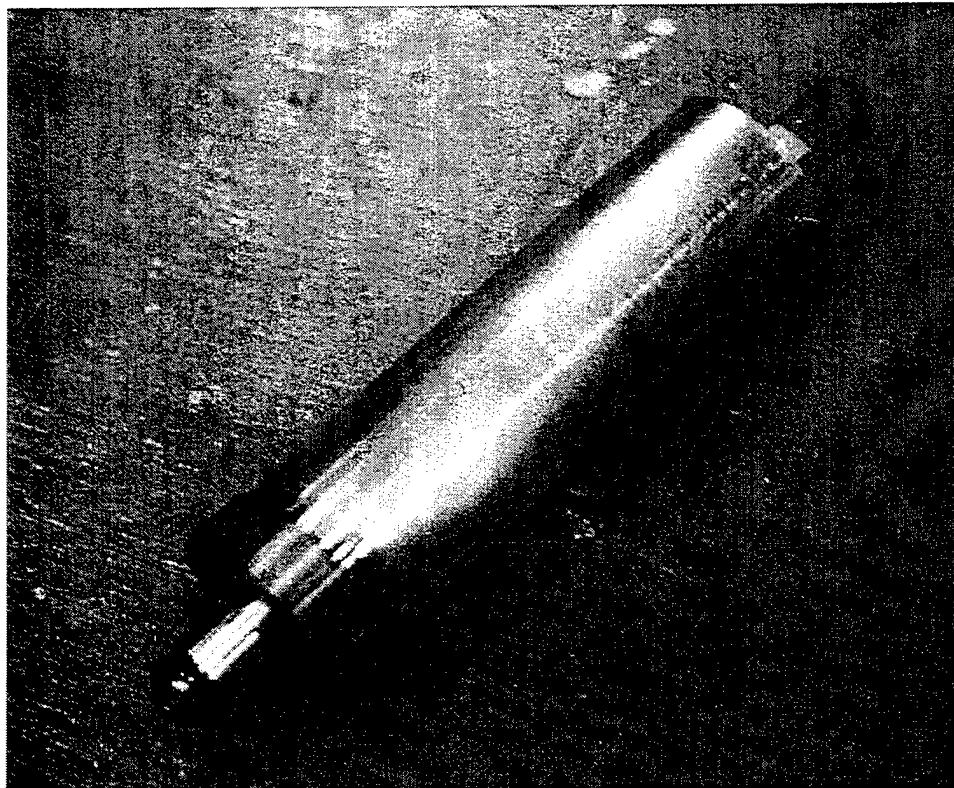

Figure 8. Acoustic navigation transponder.

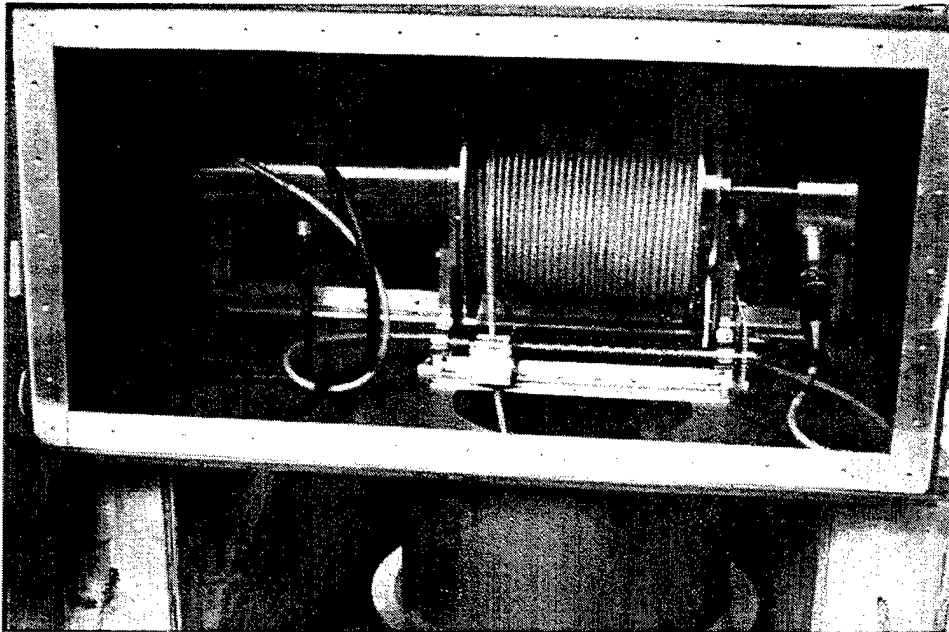

Figure 9. Inside view of Neptune deployment module.

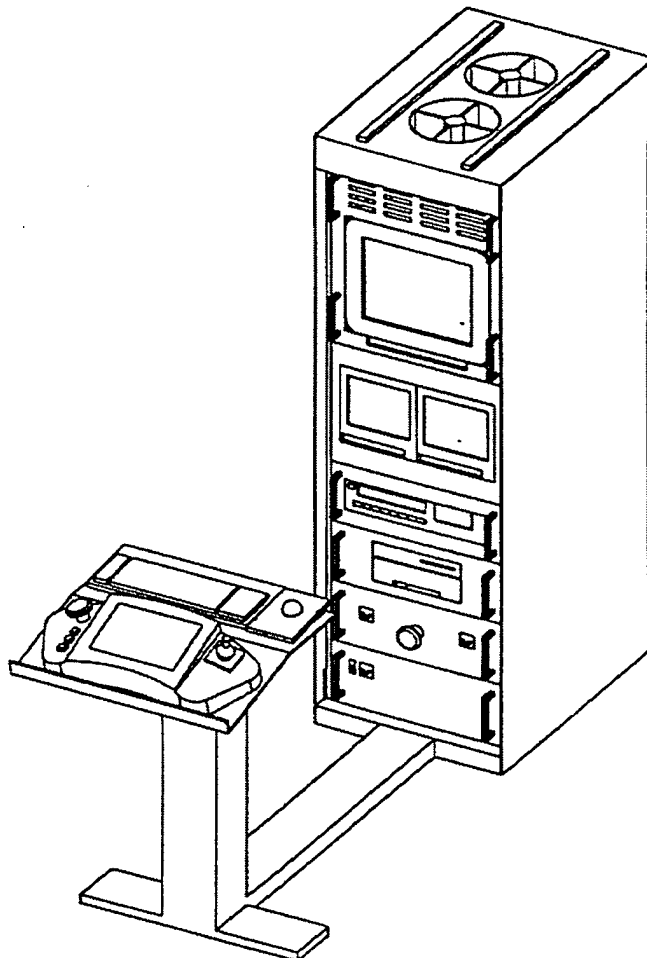

Figure 10. Illustration of Neptune control console.

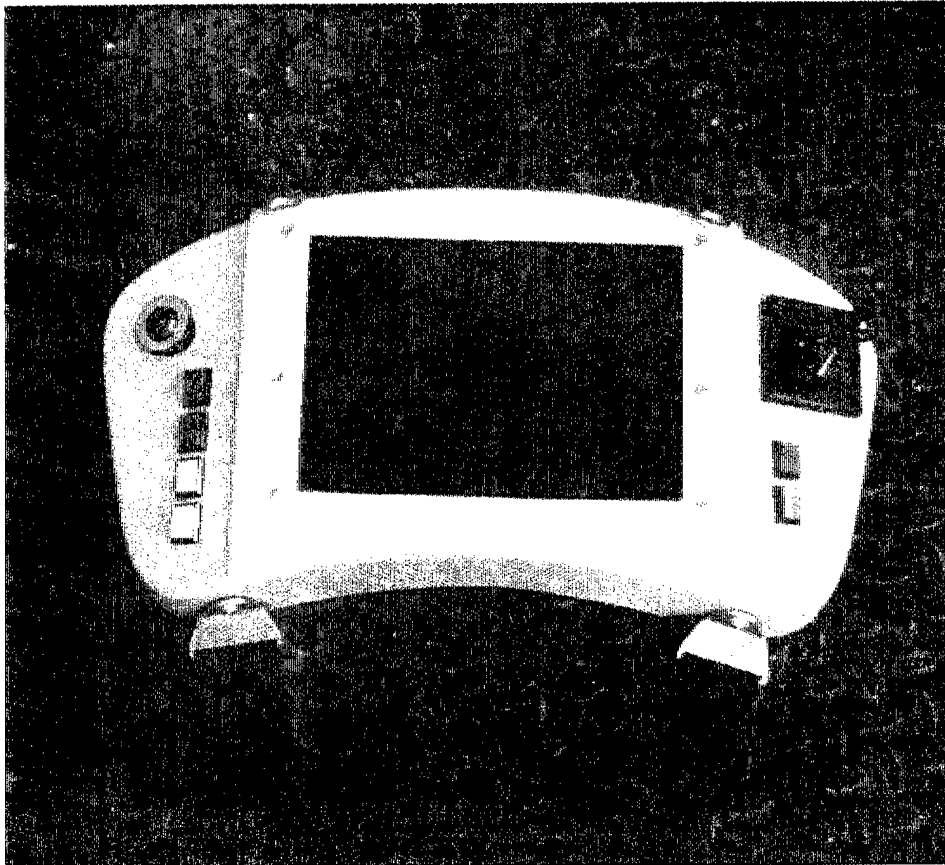

Figure 11. Portable control console for Neptune.

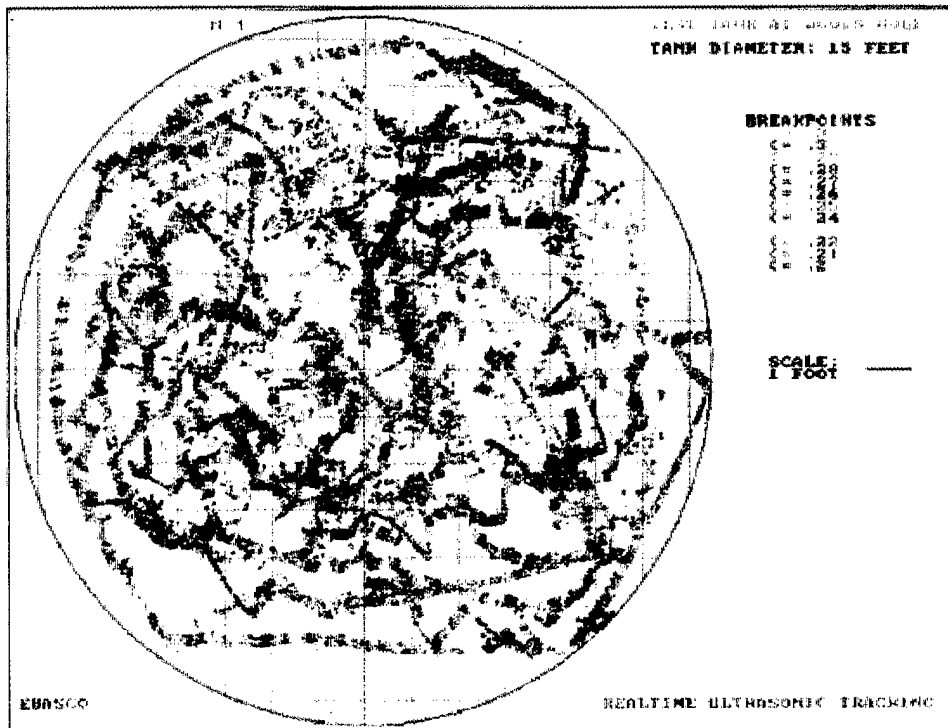

Figure 12. Thickness map from trial run Neptune UT system mounted on Raytheon's Argus robot.

## 3 Proof-of-Concept Tests

### Carnegie Mellon Acceptance Test

A 9-month delay in completion of the contract to build Neptune was followed by a partially successful proof-of-concept test conducted at Carnegie Mellon University (CMU). It was demonstrated that the crawler could navigate the floor of a small tank containing a sample tank floor plate while acquiring thickness and location data, which were combined by the Raytheon topside processor to create a thickness map. Figures 13, 14, and 15 illustrate in the laboratory the method used to launch and retrieve the system inside a tank. Figure 16 shows the completed Neptune system during the testing. Figure 17 is a close-up of the front end of Neptune showing the transition tracks and the camera housing. Figure 18 is a close-up of the rear end of Neptune showing the towed ultrasonic transducers on the sleds and the tether attachment point.

Regarding problems identified in later tests by Raytheon (see below), CMU has acknowledged that the patented switchable magnetic track design and the auxiliary "transition tracks" (see Chapter 2 under "Robot Crawler") were not functional. This problem, and the resulting delays in execution of the contract, were due primarily to undersizing of the drive motors.

### Raytheon Proof-of-Concept Tests

#### *Neptune Tests*

Raytheon elected to proceed with attempts to field-test Neptune despite the limitations described above, because the company did not consider the magnetic tracks and wall-climbing capability essential to the application. During Raytheon's initial attempts to test the crawler with the inspection system, the crawler failed to perform as specified. In an unsuccessful demonstration for Mobil, Exxon, and Shell personnel at the Mobil Oil Paulsboro (NJ) Refinery, the deployment pod, power connections to the umbilical, and the drum motor all failed.

Over the next year Raytheon modified the crawler (without cooperation by CMU, as explained below). The crawler was made functional enough to repeat CMU's basic acceptance test at the Mobil Paulsborough Refinery. Figure 19 shows a map of the data obtained from a tank measuring 30 ft x 30 ft x 20 ft deep. Raytheon subsequently used these data to enhance the post-processing software for its next-generation system. Improvements included better graphical presentation, faster data-presentation response times, and extended statistical data processing capabilities.

### ***Neptune Inspection System on Alternative Mobile Platform***

Before the CMU crawler was completed Raytheon conducted a number of field tests of Neptune's inspection system mounted on the company's free-swimming mini-rover system called "Argus." These Argus tests included navigation sensor testing in a 40 ft diameter tank at the Mobil Paulsboro Refinery; mapping of cracks in a marine mammal tank at the Sea World amusement park in Orlando, FL; and thickness mapping in a steel-lined penstock at an Elkem Metals power plant in West Virginia. The West Virginia test was partially funded by Elkem Metals, and it produced data useful to Elkem in extending the service life of the penstock.

These tests demonstrated the basic utility and versatility of the Raytheon inspection system. Raytheon used the findings of these tests with the results of the crawler test noted above to enhance the system's post-processing software.

### **Limitations of the Prototype Crawler**

As noted above, the crawler as constructed by CMU proved to be too unreliable to be demonstrated without substantial engineering modifications. Due to a dispute over intellectual property related to Neptune, CMU did not participate in Raytheon's attempts to correct the prototype crawler's deficiencies. Raytheon modified the crawler in an effort to prepare it for another field test. After a year the crawler was operational, but it was still unreliable.

After making the crawler operational Raytheon had planned to re-engineer Neptune's sensor systems for improved safety and increased coverage. However, a review of the CMU crawler design by Factory Mutual Research Corp.\* revealed that extensive modifications would be required to make the crawler safe for operation in a hydrocarbon product. CMU had engineered the prototype crawler

---

\* Factory Mutual Research Corp., 1151 Boston-Providence Turnpike, Norwood, MA 02062.

without any formal, funded advice from Factory Mutual, relying instead on a brief evaluation letter provided by Factory Mutual as a proposal. This informal approach to safety engineering presumably led to a number of important design errors that cannot be fixed to make the platform safe for operations inside a tank full of petroleum distillates or fumes.

Meanwhile, independently from this CPAR study, Raytheon had proceeded with conceptual design of its own production crawler system. This mobile platform, called "Tank Ray," incorporates lessons learned from the Neptune experience (see below) but differs greatly from CMU's basic crawler concept. Therefore, safety certification of the CMU design by Factory Mutual was not required for Raytheon's Tank Ray crawler. Finally, when Factory Mutual declined to verify that Neptune was suitable for certification, Raytheon elected to cease its efforts to certify Neptune.

After abandoning plans to certify Neptune, Raytheon still intended to use the CMU crawler to field test the production version of the sensor system. However, the continued unreliability of the crawler led Raytheon to cease further work on Neptune and proceed instead with field demonstrations of the sensor system using a modified Benthos Mini-Rover ROV as a test platform for the sensors. This is the same approach that Raytheon was using before the Neptune project.

## **Lessons Learned on Mobile Platform Engineering and Safety**

Unless commercial applications for Neptune that do not require NFPA Class 1 safety certification are identified, it is likely that Neptune's useful life will end with its role as a proof-of-concept test bed. Its principal contribution to construction productivity will have been lessons learned in the area of safety engineering for remotely operated devices to be used in flammable or explosive environments. The main safety engineering lessons learned during the Neptune project are as follows:

- An unarmored, nonpurged electrical tether such as the one used on the Neptune prototype cannot be certified for safety by Factory Mutual.
- If electrical connectors are used on the tether — or anywhere else on the crawler that is exposed to hydrocarbon products — it must be possible to purge all the way through the connector to eliminate the possibility of a leak that could ignite within the connector.
- All system components operated on the tank roof must be designed for safe operation in an NFPA Class 1, Division 1, Group D environment. An un-

purged electrical junction box within 15 ft of an open tank manway, as used in the Neptune prototype design, is not permitted by NFPA code.

- The weight and mounting details of any tank roof equipment (e.g., the deployment pod) must keep roof loading to below 25 lb per square foot to comply with customer safety regulations based on fixed tank roof design. The Neptune prototype deployment system would result in a roof loading of about 150 lb per square foot.

Raytheon has addressed these issues in the design of its production crawler.



Figure 13. Crawler hanging by tether during acceptance test at CMU.

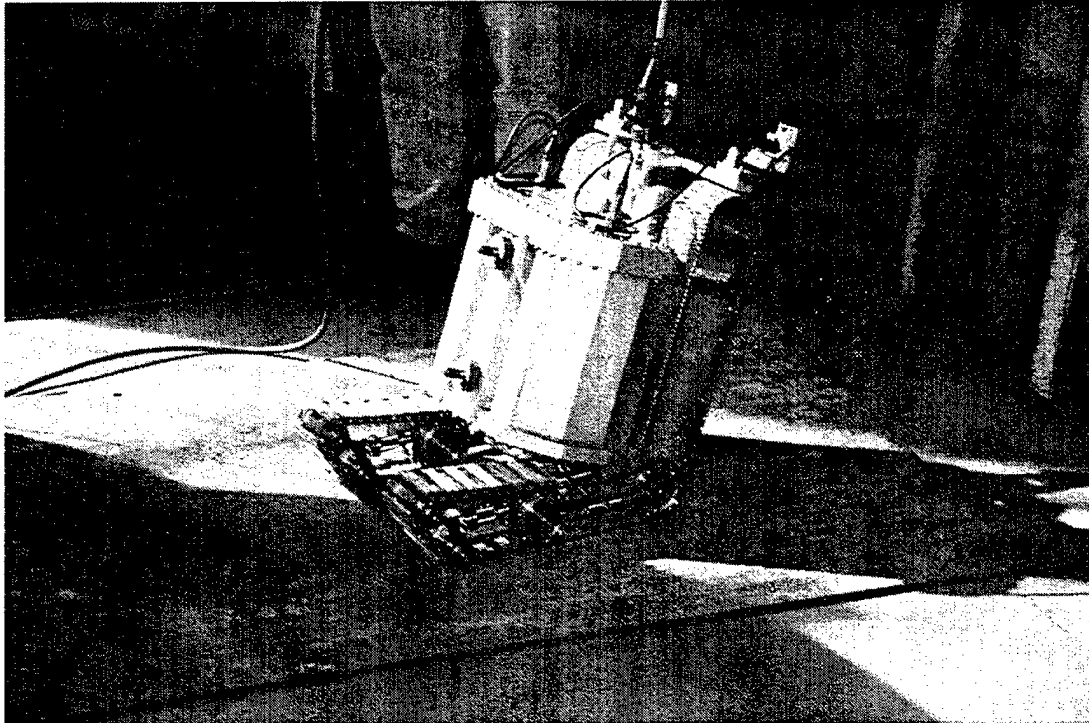

Figure 14. Crawler beginning entry procedure during CMU acceptance testing.

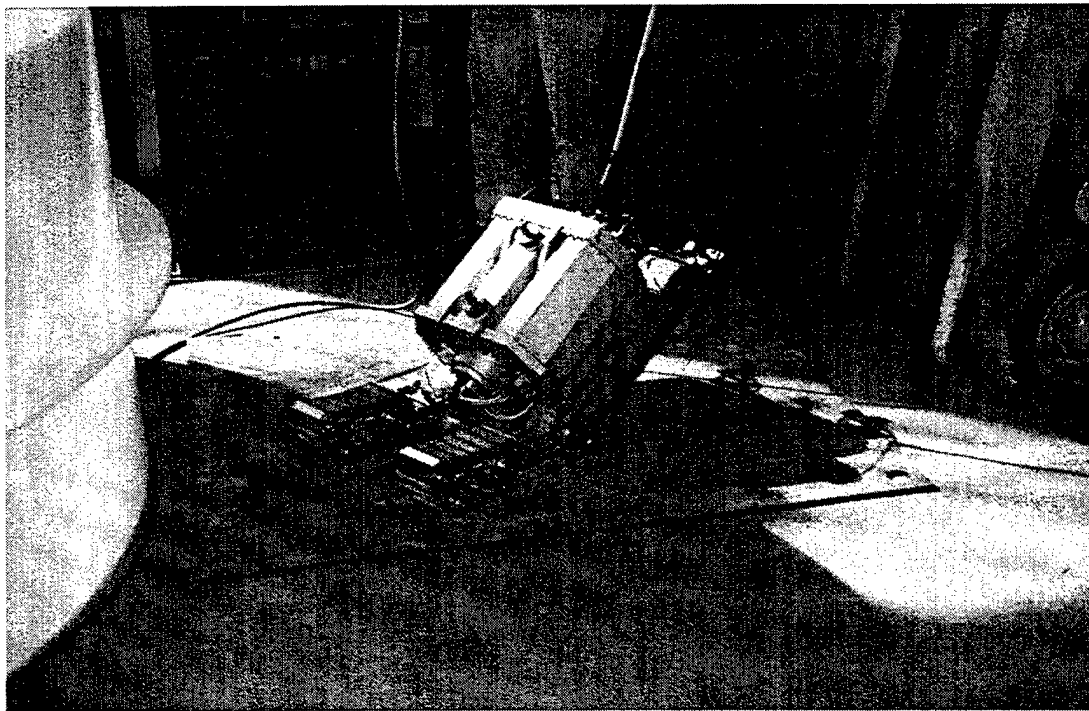

Figure 15. Crawler completing transition to floor during CMU acceptance testing.

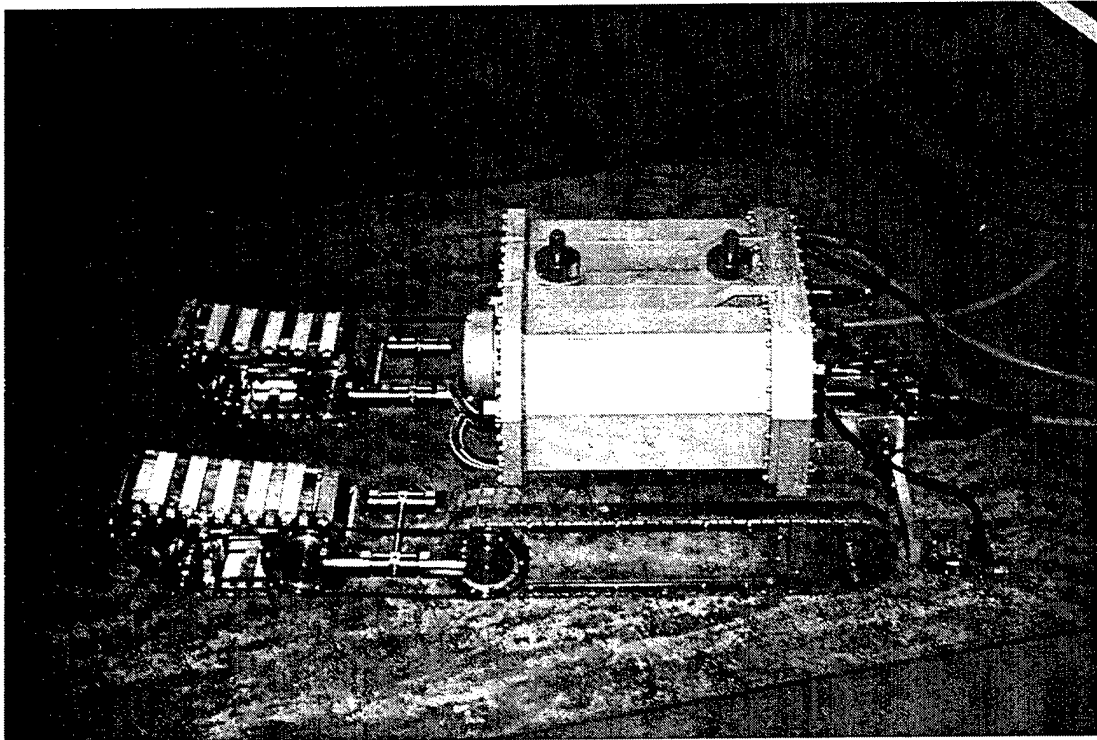

Figure 16. Crawler resting on test plate used for CMU acceptance tests.

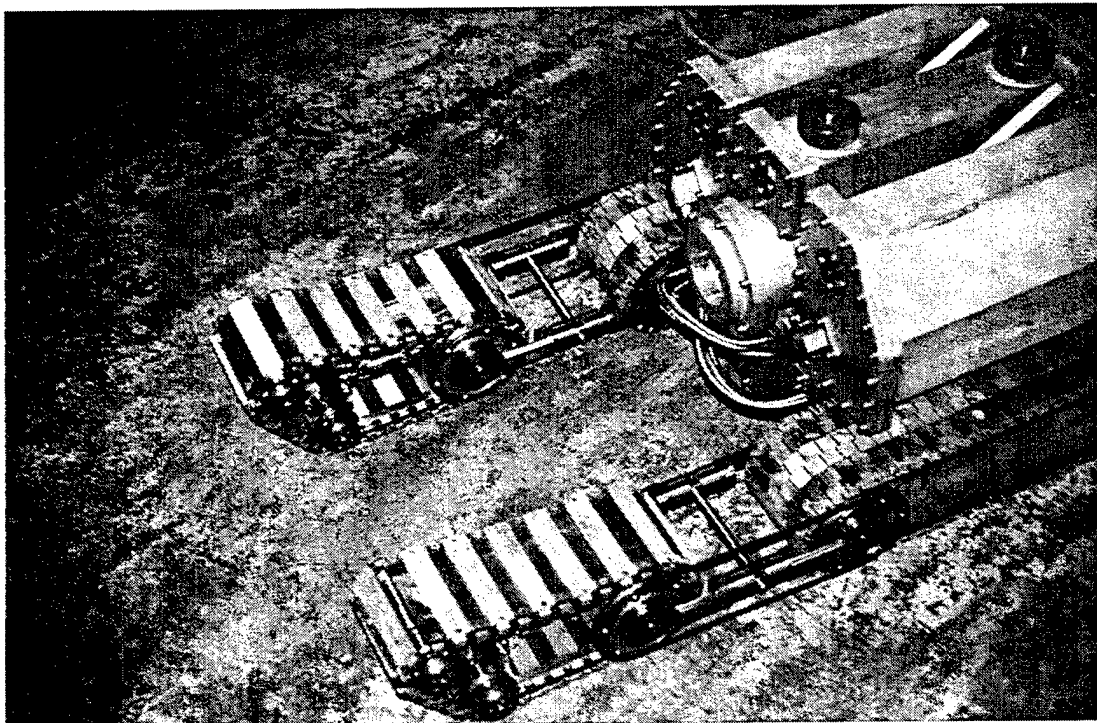

Figure 17. Close-up of the front.

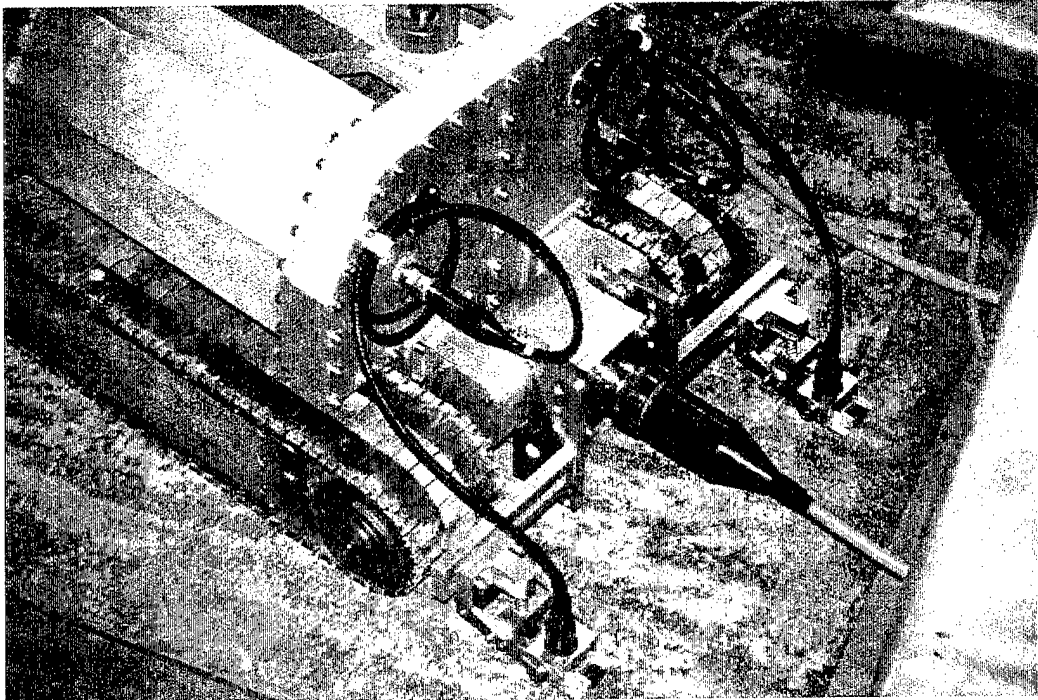

Figure 18. Close-up of rear showing UT sleds and tether connection point.

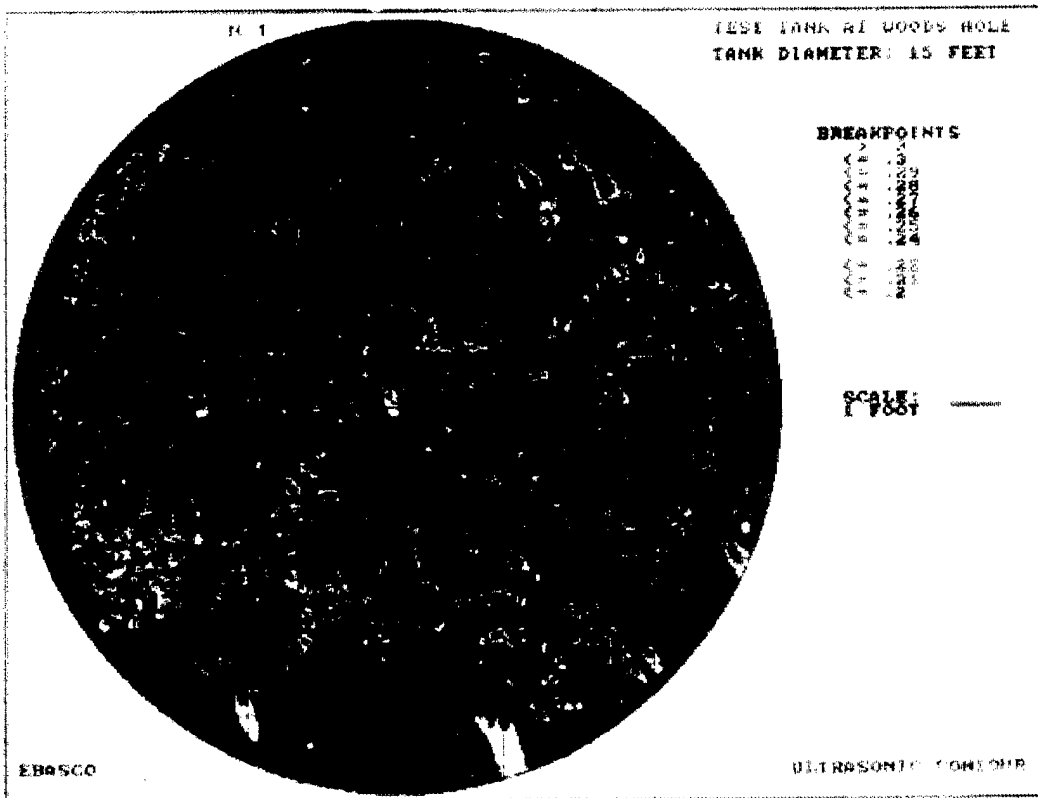

Figure 19. Contour map of Wood's Hole test data collected by Neptune UT system mounted on Raytheon's Argus robot.

## 4 Conclusions, Recommendations, and Commercialization

### Conclusions

The Neptune prototype, as designed and constructed, could only meet part of the original objectives of the CPAR-CRDA. The Neptune prototype robot could gain access to tanks through the 20 in. opening typical of ASTs, but not through the 4 in. access holes typical of USTs. The cost of miniaturizing the robot enough for access into a 4 in. entry hole was beyond the assets allocated to this work.

The system test at CMU showed that the robot could function in a tank of water and provide data on a section of steel plate. Subsequent tests, however, demonstrated that the system was unduly fragile. The deployment motor and magnetic robot tracks failed during a demonstration at Paulsboro, NJ. Further work with the unit revealed that the drive motors were underpowered for the size of the robot and strength of the magnets.

The robot as built could not pass the strict safety tests required by Factory Mutual for certification of Neptune as "intrinsically safe." The connectors were designed incorrectly for service in explosive environments; unprotected wires were used on the outside of the robot and were out of compliance with Factory Mutual guidance.

Although there were significant safety and weight problems with the Neptune crawler as designed and built for this study, it is concluded that the overall system demonstrated that the concept of on-stream testing of ASTs and water structures is viable and can be undertaken with current technology.

It is concluded that Raytheon has correctly identified engineering and safety deficiencies in the prototype crawler system, and has incorporated these findings into its own production crawler design.

## Recommendations

It is recommended that any further work based on the results of this study completely address all of the following points:

1. All NFPA codes must be complied with precisely. Careful attention must be given to all external connectors on the crawler, the power tether, and all aspects of the topside crawler deployment system.
2. The weight of the deployment pod must be reduced so the maximum load on the tank roof is no more than 25 lb per square foot.
3. Motor output needs to be sufficient to propel the crawler and handle all auxiliary demands (e.g., towed equipment, auxiliary tracks).
4. Treads must be designed for more durability considering the demands and conditions likely to be encountered while fully submerged during on-stream tank inspection.

## Commercialization

Raytheon has completed the design of Tank Ray, its next-generation on-stream AST inspection system. The Tank Ray crawler, inspection system, and software incorporate lessons learned in this CPAR project. Manufacture of the first system is underway and should be complete by the end of calendar year 1997. It is expected to be in service by mid-1998.

## References

- [1] American Petroleum Institute (API) Standard 653, *Tank Inspection, Repair, Alteration, and Reconstruction* (API, Washington, DC, January 1992).
- [2] *MWC-4200S: The Motorized Magnetic Wheel Crawler*, product literature (EMCO Intertest, Inc., Flanders, NJ).
- [3] *SCAVENGER Tank Cleaning and Inspection Systems*, product literature (ARD Corp., Columbia, MD).
- [4] *Internal Pipe-Inspection System*, product literature (Foster-Miller, Inc., Waldheim, MA, 1992).
- [5] *MWC4200S: Magnetic Wheeled Crawler*, product literature (EMCO Intertest Inc., Flanders, NJ, May 1992).
- [6] Brockelman, C., *A Robotic Inspection System for the Lower Head of a Boiling Water Reactor Pressure Vessel*, publication draft (Foster-Miller, Inc., Waldheim, MA, Spring 1993).
- [7] OPTIMA MC 7500: Single-Wire Color TV Inspection System, product literature (RICO EAB, October 1993).
- [8] Bughman, G., and S.L. Jones, "Robotic Cleaning of RadWaste Tank Nozzles," *Proc. 36th Conf. Remote Systems Technology*, vol.2, p 35, 1988.
- [9] NFPA 30, *Flammable and Combustible Liquids Code* (National Fire Protection Association, Quincy, MA, January 1990).
- [10] *National Electric Code Handbook - 1993* (National Fire Protection Association, Quincy, MA, 1993).
- [11] Code of Federal Regulations Title 40, Part 280, *Technical Standards and Corrective Action Requirements for Owners and Operators of Underground Storage Tanks*.

**USACERL DISTRIBUTION**

## Chief of Engineers

ATTN: CEHEC-IM-LH (2)

ATTN: CEHEC-IM-LP (2)

ATTN: CEMP-ET

ATTN: CERD-L

ATTN: CERD-M

ATTN: CERD-C (2)

ATTN: CECW-E (3)

ATTN: CECW-O (2)

## U.S. Army Engineer Districts

ATTN: Library (40)

## U.S. Army Engineer Divisions

ATTN: Library (11)

## Defense Tech Info Center 22304

ATTN: DTIC-O (2)

67

+10

12/97