

JPRS-JST-92-012
10 APRIL 1992



**FOREIGN
BROADCAST
INFORMATION
SERVICE**

JPRS Report

DISTRIBUTION STATEMENT A

Approved for public release
Distribution Unlimited

Science & Technology

Japan

NEW TRENDS FOR ADVANCED MATERIALS

19980128 185

DTIC QUALITY INSPECTED 8

REPRODUCED BY
U.S. DEPARTMENT OF COMMERCE
NATIONAL TECHNICAL INFORMATION SERVICE
SPRINGFIELD, VA. 22161

SCIENCE & TECHNOLOGY
JAPAN

NEW TRENDS FOR ADVANCED MATERIALS

916C0044 Tokyo SENTAN ZAIRYO NO SHIN CHORYU SYMPOSIUM in Japanese 28 May 91
pp 18-74

[Selections from the Proceedings of the Symposium on New Trends in Advanced
Materials held 28 May 91 in Chiba, sponsored by the Science Council of Japan
and the Society of Polymer Science]

CONTENTS

I. Intelligent Materials

Need To Develop Materials With Intelligent Response Capacity [S. Miyata].....	1
S&T Agency's Intelligent Material R&D Strategy [T. Shirao].....	20
Design of Intelligent Molecular Materials [T. Miwa, et al.].....	21
New Drug Release System Utilizing Complex Reaction of Polymers [S. Kitano, M. Yokoyama, et al.].....	23
Analysis of Temperature Responsive Drug Release [H. Kamitomo, M. Okano, et al.].....	25
New Glucose Responsive Insulin Release Gel [T. Shiino, Y. Koyama, et al.].....	27
Protein Device To Release Insulin in Response to Glucose [Y. Itoh, et al.].....	29
Intelligent Materials Based on Responsive Polymer, Biocatalyst [H. Ichijo, et al.].....	31

High-Efficiency Chemomechanical Materials [H. Okuzaki, et al.].....	33
Grafted Porous Membrane With Responsive Pores [Y. Itoh].....	35
Design of Intelligent LB Membrane Oscillating Laser Beam [S. Miyata, et al.].....	37
Potential for Intelligence Manifestation in Ceramic Sensors [Y. Nakamura, et al.].....	39
II. Functionally Gradient Materials	
Development of Functionally Gradient Materials [M. Shinno].....	41

I. Intelligent Materials

Need To Develop Materials With Intelligent Response Capacity

916C0044A Tokyo SENTAN ZAIRYO NO SHIN CHORYU SYMPOSIUM in Japanese 28 May 91
pp 18-32

[Article by S. Miyata, School of Engineering, Tokyo University of Agriculture and Technology: "Promotion of Comprehensive Research and Development To Create New Substances and Materials With the Ability To Respond Intelligently to Environmental Conditions and Functions: Report to Consultation No. 13"]

[Text] Introduction

In the 21st century, we undoubtedly will face many problems that will be extremely difficult to solve, such as population, energy, environment, and the redistribution of resources. The current population of China alone, for example, far exceeds that of all the so-called advanced nations. When the Chinese people as a whole reach the point where they consume as much energy and materials as the Japanese do at present, it is very likely that China will be a kind of black hole that will swallow every kind of energy. This does not mean, however, that developing nations should be prevented from progressing to permit the advanced nations alone to use the world's resources as they like. Instead, it is time that we begin to consider ways to improve life on a global basis while using less energy and fewer resources.

In this regard, intelligent materials can play a great role in solving the difficult problems that human society will face. These are "materials that can respond intelligently to environmental conditions and functions." To this end, they need to have built-in sensing, processing, and actuating functions. Conventional material functions are individually independent, and signals from sensor materials have to undergo computer processing before being sent as instructions to the actuator to perform a particular task. Such a system requires a substantial investment in materials and software. This in turn leads to high consumption and high prices, thereby preventing many people from enjoying their benefits. In contrast, intelligent materials that are provided with functions on the atomic or molecular level, are likely to require fewer resources and less energy, and to be lower in price. Furthermore, in the future such materials will have software incorporated within themselves. It is likely that such materials will make a significant contribution to the progress of human society.

In recent years, in fields where the materials themselves must perform with a high degree of reliability in such hazardous environments as aviation, space, and atomic energy, basic studies on approaches to ensure reliability and to cope with environmental conditions based on new ideas have been promoted. The goal of this effort is not only to improve material reliability, but also to provide to materials themselves functions to prevent accidents through self-diagnosis of deterioration, to control or repair damage, and to predict operational life. Studies involving intelligent materials have been conducted individually. It is extremely important, however, to proceed in an integrated manner, and to establish the idea of intelligent materials.

For these reasons, the Science and Technology Agency, which has been working on this problem since 1987, submitted a report in 1989, and in 1990 established an intelligent materials workshop in the Unexplored Science and Technology Association. This has promoted dissemination of the concept and relevant research and development.

This article reports on the state of research and development for intelligent materials. It is based on the report of this symposium and on the first intelligent materials symposium that was held recently.

Report on "Promotion of Comprehensive Research and Development To Create New Substances and Materials With the Ability To Respond Intelligently to Environmental Conditions and Functions" (Report No. 13)

Table 1. Intelligent Quality Viewed From Human Side

Environmental harmony	Materials can function as intended while maintaining harmony with natural environments and human society.
Profitability and resources saving	Materials can be manufactured and made available at a cost corresponding to their functions (profitability). Materials can be manufactured by utilizing resources effectively or by conserving scarce resources (resources saving).
Comformability	Materials will conform easily and be harmonious with the humans who utilize them, and will display properties suitable for the environments in which they are used, or will be desirable to the humans who utilize them.
Reliability	Materials will be able to perform their functions in a stable manner and at a high level under the required service conditions.
Optimum	Material life will be optimized and not longer than necessary given the required service conditions from the standpoints of harmony with natural environments and utility to human society.
Analytic decision	Materials will provide individual and analytic processing of information on changes in environments, etc., for optimum decisions.
Rationality and nonrationality	While analytic decision, and comprehensive recognition and decision, are largely based on rationality, they include some elements based on nonrationality, which are partially, and temporarily illogical but as a whole finally produce optimum results.
Comprehensive recognition and decision	Materials will detect information on environmental changes, etc., as a whole and make decisions accordingly.
Overall harmony	Material functions will be harmonious as a whole so that they will be effective and optimal in relation to specific environments, places, and time.

Table 2. Intelligent Qualities of Material Itself

Intelligent quality of material	Significance in intelligent material	Significance in organism
Self-multiplication and growth	For a material to form or grow the same as itself, and automatically stop doing so when necessary. (S), P, E	Self-multiplication: For a cell or an individual organism to self-produce a cell or an individual organism of the same kind as itself. (Excerpt from a physicochemical dictionary)
Self-recovery	For a material to repair damaged portions of itself or to recover its functions (including substitutes) when it receives some damage or becomes unable to display its original functions due to environmental or internal changes	Recovery: A phenomenon where damaged portions of individual and tissue levels, and cellular and molecular levels return to their normal state, which can be found in processes of DNA recovery and curing of tissues and organs. (Excerpt from a biological dictionary)
Autolysis	For a material to rapidly autolyze to assimilate itself to environments when its functions as a material terminate. S, P, E	Autolysis: A phenomenon where substances forming cells and tissues decompose even under aseptic conditions when they are dead or destroyed. (Excerpt from a biological dictionary)
Redundancy	For a material to achieve sound functions and smooth response by supporting its original functions or by substituting for them means of preprovided abilities usually unnecessary to function when environmental or internal changes exceeding ordinary anticipation are encountered and are likely to prevent material functions from being displayed.	Organisms seem to retain sufficient allowance in their construction and functions. Redundancy: The rate of unnecessary portions to the maximum quality of information transmitted signals can possess. While large redundancy reduces efficiency, it can prevent to a considerable extent information from being lost when part of communication is lost. (Excerpt from a physicochemical dictionary)

S: Sensor function; P: Processor function; E: Effector function
[continued]

[Continuation of Table 2]

Intelligent quality of material	Significance in intelligent material	Significance in organism
Self-diagnosis	For a material to detect information concerning its own state involving its soundness and to determine the occurrence of defects involving a deterioration of functions or a functional manifestation S, P	Diagnosis: For a material to determine deterioration, and locations of equipment defects, based on information obtained examining the ordinary state of operation of the equipment. When this decision is implemented by a specific program, it is called self-diagnosis. (Excerpt from a dictionary of science)
Learning	For a material to store information concerning environmental or internal changes and processing, decision and motions to cope with them, and to quicken response speed or provide excellent response with similar changes thereafter. (S), P, (E)	Learning: When an action shows a permanent change to some extent through experience, it is said that learning has occurred. What is not intrinsic but learned in environments through experience is called active learning. (Excerpt from a biological dictionary)
Prediction and notification	For a material to predict changes and phenomena, and to cope with them in an optimum manner, or to provide information to exterior when there are constant changes or responses in the environment or in interior. S, P, (E)	Organisms predict the future by learning and take action according to the prediction.
Self-assembly	For a material to form polymer with similar or other materials, make it effective in manifesting functions of itself or other materials. S, P, E	The system itself gradually improves its own structures and functions.

S: Sensor function; P: Processor function; E: Effector function
[continued]

[Continuation of Table 2]

Intelligent quality of material	Significance in intelligent material	Significance in organism
Feedback	To transmit information on sensor, processor, and effector functions to the various places to be available for future inquiries.	Feedback: To return signals on output side to input side by forming a closed loop in a system. Organisms possess various hierarchical control mechanisms contributing to manifestation of homeostasis. (Excerpt from a biological dictionary)
Standby	For a material to be maintained so that it can be actuated whenever necessary. (S), P, (E)	Organisms constantly retain themselves in actuatable condition.
Recognition and discrimination	For a material to discriminate environmental (or internal) changes or information by deciding whether they are useful to itself individually or as a whole (on a fuzzy basis).	Recognition: When an organism can discriminate itself or what is suitable for itself from what is not itself. It sometimes includes changes, reaction, or actions resulting from an organism receiving some impulse by its acceptor and discriminating it. Discrimination: For an animal to obtain two impulses different in quality or quantity. (Excerpt from a biological dictionary)
Information integration	For a material to retain accumulated information collected in the past. P	Organisms transmit to their descendants' past accumulated information in the form of genes.
Time-functional responsibility	For abilities as materials to be functions of time according not only to environmental changes but also to purposes. P	

S: Sensor function; P: Processor function; E: Effector function

[continued]

[Continuation of Table 2]

Intelligent quality of material	Significance in intelligent material	Significance in organism
Self-adaptation, adjustment to surroundings	For a material to fulfill its optimum functions by changing itself (functions and characteristics) linearly or nonlinearly, or environments according to environmental changes. S, P, E	Adaptation: A physiological term generally meaning that functions, properties, and conditions of an organism change according to external conditions, continuous environmental conditions, in particular, to be adaptive to its life. It is an antonym of reaction, an organic change according to rapid changes in external conditions, generally implying a gradual change. (Excerpt from a biological dictionary)
Homeostasis	For a material to adjust its own condition according to environmental changes, to keep its functions constant. S, P, E	Homeostasis: A property that an organism keeps itself stable morphologically and physiologically, and maintains its existence as individual in both external and incessant internal changes. (Excerpt from a biological dictionary)

S: Sensor function; P: Processor function; E: effector function

Table 3. Basic Functions of Intelligent Qualities

Sensor function	Function for detecting information on environments or the interior of materials
Processor function (including storage function)	Function for processing and making decisions based on detected information or information intrinsically possessed by materials. Function for storing (recording, retaining, and reading) information, and the process and results of its processing and decisions.
Effector function (actuator function)	Function for outputting one effect or another, based on results obtained by sensor or processor function.

[continued]

[Continuation of Table 3]

Systematic information transmitting function	Function for organically transmitting information for systematically and cooperatively manifesting sensor, processor, and effector functions.
Energy conversion/supply function	Function for supplying the energy necessary to manifest functions from environments and the interior of materials. If the type of energy supplied is different from that necessary to manifest material functions, a function for converting energy will be necessary.
Basic physical, chemical function and construction	Basic constructions, properties, and functions intrinsically possessed by the substances comprising the materials.

Table 4. Detailed Profiles of Currently Conceivable Intelligent Materials
(Examples for understanding concepts)

Applied field	Detailed example
Structural material	<ul style="list-style-type: none"> • A material that can prevent the growth of cracks generated in a reinforcing member due to repeated stress by varying its own volume through stress-induced transformation caused at its end, and by providing compressive stresses in the neighborhood of the cracks (recognizing/discriminating abilities, redundancy) • A material that can recognize the load speed of a stress exerted on it, and, when deciding what a stress should be, not static but impulsive, display heavy strength (recognizing/discriminating abilities, redundancy) • A material that can issue alarms against deformation or damage, prevent them from making progress, or return them to their original state over time (for use in automobile bodies and aircraft) (self-diagnosis, prediction, and notification, self-recovery) • A material that can be used in an extremely wide range of temperatures, from very low to ultrahigh temperatures, thanks to its ability to change in phase or to react chemically according to temperature to be converted properly into another substance according to environmental conditions (heat-resistant materials for use in space shuttles, etc.) (environmental responsiveness)

[continued]

[Continuation of Table 4]

Applied field	Detailed example
Electric/electronic material	<ul style="list-style-type: none"> • A varistor that, when a pulse-like voltage acts repeatedly, can supply oxygen by detecting the degree of deterioration or oxygen hole amount, and then recover (self-recovery) • A material for generating a microconstant current that can sensitively vary resistance so as to keep the amount of current constant by changing resistance values according to temperature changes (homeostasis)
Optical material	<ul style="list-style-type: none"> • An optical material that can transmit an optimum amount of light not according to the amount of incident light, but to the environment it is in and depending on the specific purpose (materials for use in sunglasses, window glass for automobiles, and housing) (recognizing/discriminating abilities) • A material that can control refractive indexes, transmissivity, and reflectivity by varying its optical property through changes in electric and magnetic fields, and temperature (varifocal lenses for use in automatic focusing cameras) (environmental responsiveness)
Bio-/medical materials	<ul style="list-style-type: none"> • A biomaterial implanted in an organism that can grow or decompose as the host organism grows or recovers from a disease (artificial bones, etc.) (self-multiplication and growing, autolysis) • A medical material that can discriminate and adsorb cancer-cells, and gradually discharge an anticancer drug according to situations (material for use in anticancer microcapsules) (recognizing/discriminating abilities, standby)
Miscellaneous	<ul style="list-style-type: none"> • A gas-type sensing material that can recognize the type and amount of an adsorbed gas, and when the amount of a gas exceeds a given level, initiate a different level of current flow corresponding to the type of gas (recognizing/discriminating abilities) • An adhesive material that can maintain a predetermined level of adhesive strength during use, but that become easily separated upon self-determination of the completion of use (materials for use in clothing and heat insulators) (feedback function, environmental responsiveness) • A packaging material that can promote or control the ripening of vegetables by regulating the transmission amount of an ethylene base and display when they are ripe enough to eat (environmental responsiveness)

Table 5. Mechanism for Manifesting Intelligent Qualities

Change in molecular structure	Intermolecular coupling, molecular cutting, changes in coupling distance or changes in stereostructure (molecular inversion, etc.). It includes part of enzyme reaction, antigen-antibody reaction, or an adsorption phenomenon.
Change in crystal structure	Changes in interatomic distance, atomic arrangement, and orientation in a crystal. This sometimes causes phase transfer (phase transformation). With crystalline macromolecules, it implies such changes as extension from the state where a molecular chain is folded.
Change in surface, interface, and grain boundary	Changes in interface such as crystal grain boundaries. Ceramics have grain boundary layers with different compositions, which implies a structural change. For metals, meanwhile, it implies slip in grain boundaries. It also implies changes in surfaces due to absorption.
Macro-change	Changes based on diffusion and migration, not at the atomic or molecular levels, but in bulky blocks, and the movement of crystal grains or a fluid.
Compositional change	Changes in material composition resulting from foreign matter penetrating into materials.
Migration of ions and radicals	The migration of a specific atom or ion in the interior of a material, or the migration of a radical or group along a polymeric chain in a polymer. It includes apparent migration caused by a substituting reaction.
Change in electronic structure	Changes in magnetism resulting from a change in the orientation of an electronic piston with no change in molecular and crystal structure.
Charge transfer and accumulation	Charge-transfer and electrification resulting from conductivity or semiconductor qualities in ceramics and metals. For organic matter, this implies charge-transfer along a polymeric chain or charge accumulation by resonance structure, etc.
Change in energy	Adsorbing, transferring, and discharging energy from electrons, photons, heat, and sound.
Change in property constant	Changes in property constants, such as melting points, solidifying points, glass transition points, Curie points, and absorption coefficients.

Table 6. Intelligent Quality of Materials Themselves and Their Manifestation Mechanisms

Intelligent quality of material	Related mechanism	Candidate intelligent material	*Example of material with property deserving intelligent one at present
Self-multiplication and growth	Change in molecular structure Change in crystal structure	<ul style="list-style-type: none"> •Material which can detect cracks and defects, self-multiply and self-recover by fetching substances from its interior and exterior •Material which makes it possible for junctions to be disengaged in the body as it grows, a polymeric chain to extend, and the reduced structure to grow 	Hydroxyapatite (artificial bones) Artificial blood tubes made of collagen
Self-recovery	Change in crystal structure (phase transformation) Change in surface interface and grain boundary	<ul style="list-style-type: none"> •Self-recoverable varistor which can prevent deterioration by automatically recovering from deterioration caused by repeated surge •Material which can automatically cover an original shape by its shape recovery ability through phase transformation and the growth of oxides when external forces, such as deformation and fracture, are exerted in automobile bodies, etc. •Material which can detect deterioration of material characteristics when entrained foreign matter adhere to material surface, clean surface by catalytic (enzyme) actions and recover its function 	Denatured zinc oxide hybrid varistor, shape memory material (alloys, resins, fibers)
Autolysis	Change in molecular structure	<ul style="list-style-type: none"> •Building material which can self-determine its own needs and allow its adhesive force to change 	Materials for use in microcapsules such as anti-cancer drugs

[continued]

[Continuation of Table 6]

Intelligent quality of material	Related mechanism	Candidate intelligent material	*Example of material with property deserving intelligent one at present
Redundancy	Macrochange	<ul style="list-style-type: none"> •Material which can determine necessity of discharging drugs, etc., and, when unnecessary, decompose itself to same level as a polymer in an organism due to a change in molecular structure 	Ultraplastic alloys (Al-Zn alloy, two-phase Ti alloy, etc.)
	Change in molecular structure	<ul style="list-style-type: none"> •Material for reinforcing members of high reliability which can display heavy strength when deciding a stress exerted on it by phase transformation to be, not static, but impulsive 	
	Change in crystal structure	<ul style="list-style-type: none"> •Material which can relax stress concentration through stress induced transformation caused in stress-concentrated areas like cracks 	
	Change in molecular structure Change in crystal structure	<ul style="list-style-type: none"> •Material which can self-diagnose state of its own deterioration, etc., based on changes in color tone and on energy discharged following induced transformation caused by stress 	
Self (interior)-diagnosis	Change in surface, interface, and grain boundary	<ul style="list-style-type: none"> •Material which can get a functional suspension period according to environmental conditions: material which is normally used in nonequilibrium and stops functioning in equilibrium 	

[continued]

[Continuation of Table 6]

Intelligent quality of material	Related mechanism	Candidate intelligent material	*Example of material with property deserving intelligent one at present
Learning	<p>Change in molecular structure Change in crystal structure Change in property constant (non-equilibrium)</p>	<ul style="list-style-type: none"> •Material which can learn responsiveness to environmental changes and memorize them as remains and defects of structural changes, and generate signals in the form of current, etc., by applying arbitrary weight to them through a comparison between them and environmental changes thereafter •Material whose absorption coefficient with specific wavelengths of a laser beam changes due to a photochemical hole-burning phenomenon, and whose response speed becomes optimum through experience 	<p>Photoelectronics material Parallel operational device Memory and switching devices using LB films</p>
Prediction and notification	<p>Change in molecular structure Change in crystal structure (phase transformation) Change in energy</p>	<ul style="list-style-type: none"> •Material which can change its color tone and discharge energy when encountering stress induced transformation caused by mechanical fatigue, thereby informing the exterior of its fatigue or relaxation •Material which can inform the exterior of its deterioration by changing the color of cholesteric liquid crystal as it deteriorates •Material which can predict the time of its fracture by making sound or discharging electrons by means of a metal, etc., through changes in its crystal structure 	<p>Cu-Zn-Al alloy</p>

[continued]

[Continuation of Table 6]

Intelligent quality of material	Related mechanism	Candidate intelligent material	*Example of material with property deserving intelligent one at present
Hutolysis	Change in molecular structure Change in crystal structure	<ul style="list-style-type: none"> •Material which is an aggregate comprising several materials each having a single function, enabling functions to be manifested systematically and cooperatively •Material which can display material functions (synthesis and catalyst) as an aggregate under constant environments which become discrete, and cannot display them under unstable environments 	
Feedback	Change in molecular structure Change in crystal structure Compositional change Migration of ions and radicals Charge migration and accumulation	<ul style="list-style-type: none"> •Material which can recognize external environments (temperature, humidity, etc.) and control its own performance (insulating ability, permeability, etc.) •Heater material which is small in resistance at below phase transformation temperature, can play the role of heater when current flows, control its own temperature by rapidly increasing resistance when temperature exceeds phase transformation temperature due to self-heating, and allow phase transformation temperature to change according to temperature of the environment it is used in 	Polymeric fibers with shape memory function, shape memory alloys (resins) of honeycomb structure

[continued]

[Continuation of Table 6]

Intelligent quality of material	Related mechanism	Candidate intelligent material	*Example of material with property deserving intelligent one at present
Standby	Change in molecular structure Change in crystal structure Change in energy (non-equilibrium)	<ul style="list-style-type: none"> •Material which can convert energy, such as light and heat, it receives into electric energy, accumulate it in itself as changes in structure or distortion, and discharge it at a stretch when necessary •Material which can sense liberation of heat and change its molecular structure in response to it to vary its film permeability, thereby discharging a febrifuge 	Solar energy storage material (indigo pigment), DDS
Recognition and discrimination	Change in molecular structure Change in crystal structure (phase transformation) Change in surface, interface, and grain boundary Macrochange Compositional change (enzyme reaction) Charge migration and accumulation	<ul style="list-style-type: none"> •Material which can sense cancer cells, adsorb them, and gradually discharge a cancer drug •Material which can recognize load speed of a stress, decide whether the stress is impulsive or static, and display heavy strength against the former •Material which can recognize type and amount of an adsorbing gas and, when an amount of gas exceeds a given level, allow a different level of current corresponding to the type of gas to flow •Material which can recognize internal and external temperature and humidity conditions by causing different phase transformations, thus allowing permeability and thermal conductivity to change 	Ruthenium membrane temperature difference sensor, molecular film heterozygous biodevice (photoswitch), conductive polymeric membrane biosensor, gas-type sensing current control material, high density LSI, temperature dependent fiber, diagnostic polymer, polymeric piezoelectric material applied human sensor, humidity sensor

[continued]

[Continuation of Table 6]

Intelligent quality of material	Related mechanism	Candidate intelligent material	*Example of material with property deserving intelligent one at present
Information integration	(structural change, state residual)	<ul style="list-style-type: none"> •Material which can detect changes in body fluid components utilizing enzyme reaction and can diagnose diseases •Memory material which can highly integrate in itself information obtained from external environments, store this information as corresponding changes in structure and condition, and output the information as necessary 	using amorphous membrane, oxygen selective transmission film, microcancer detection-use functional dye, ceramic (temperature, optical, piezoelectric, humidity, gas, oxygen gas)
Time-functional responsiveness	Change in molecular structure Change in crystal structure Macrochange	<ul style="list-style-type: none"> •Adhesive material which can maintain an adhesive force during use, but, when not in use, can easily be separated based on its own decision •Material which can arbitrarily set a functional suspension period 	
Environmental responsiveness	Change in molecular structure Change in crystal structure Change in property constant	<ul style="list-style-type: none"> •Material which can change its optical characteristics according to changes in electric and magnetic fields and temperature, and can control its refractive index, transmissivity, and reflection factor (automatic focusing camera-use varifocal lens, etc.) 	Artificial muscular material, film-like electrostatic actuator, piezoelectric/electrostriction actuator, light reactive

[continued]

[Continuation of Table 6]

Intelligent quality of material	Related mechanism	Candidate intelligent material	*Example of material with property deserving intelligent one at present
Homeostasis	Change in crystal structure Change in property constant	<ul style="list-style-type: none"> •Lubricating hardened film which can change its condition between a fluid and a solid state according to dynamic or thermal conditions •Material which can change its volume according to environments in organisms (artificial cardiac material, etc.) •Microconstant current generating material which can sensitively change its resistance so as to keep the current level constant by feeding back h change to affect changes in resistance values 	PLZT (piezo-electric ceramic) actuator

* It is desired that these properties will change in an optimum manner according to environmental and operating conditions.

Table 7. Three Factors Related to Intelligent Qualities and Manifestation Mechanisms

Three factors		Sensor function					Processor function					Effector function							
Manifestation mechanism	Area	Optical	Electric	Magnetic	Dynamic	Thermal	Chemical	Optical	Electric	Magnetic	Dynamic	Thermal	Chemical	Optical	Electric	Magnetic	Dynamic	Thermal	Chemical
Change in molecular structure (organic matter)	Coupling, cutting Coupling distance Stereostructure (molecular version)	○ ○ ○			○ ○	○ ○ ○	○ ○ ○						○ ○ ○	○ ○ ○			○ ○		○ ○ ○
Change in crystal structure	Ceramics Metal Organic matter	○	○ ○	○ ○	○ ○ ○	○ ○ ○							○	○ ○	○ ○	○ ○	○ ○	○	
Change in surface, interface, and grain boundary	Grain boundary (ceramics) Grain boundary (metal) Surface	○ ○	○ ○	○ ○ ○	○ ○		○							○ ○	○ ○	○ ○	○ ○	○	○
Macrochange					○									○	○	○	○		
Compositional change		○	○	○			○								○	○	○		○
Migration of ions and radicals				○		○							○		○	○			○
Change in electronic structure (orientation of electron spin)				○											○	○			
Charge migration and accumulation			○	○											○	○			
Change in energy absorption, transport, and discharge		○	○	○	○	○	○	○	○	○	○	○	○	○	○	○	○	○	○
Change in property constant		○		○	○	○	○	○	○	○	○	○	○	○	○	○	○	○	○

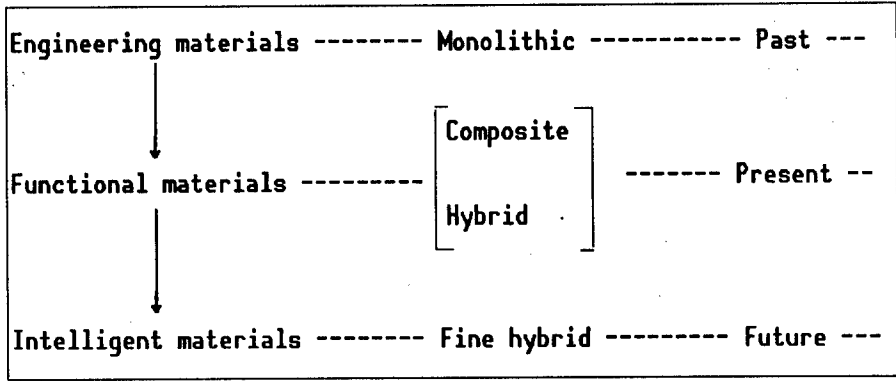

Evolution of Material Concepts

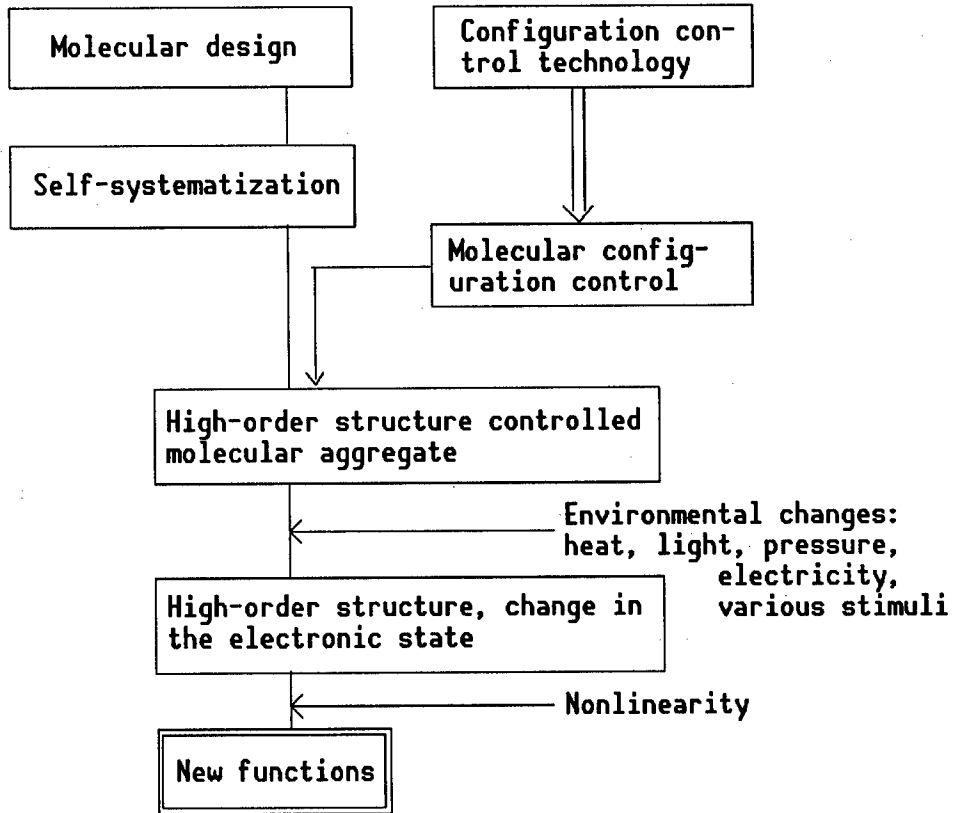

Approach to Intelligent Materials

S&T Agency's Intelligent Material R&D Strategy

916C0044B Tokyo SENTAN ZAIRYO NO SHIN CHORYU SYMPOSIUM in Japanese 28 May 91
p 33

[Article by T. Shirao, Material Development Promotion Office, Research and Development General Research Division, Science and Technology Agency: "Efforts To Budget for Intelligent Structural Materials"]

[Text] Three and a half years have passed since the Council for Aeronautics, Electronics, and Other Advanced Technologies—an advisory committee to the director-general of the Science and Technology Agency—received consultation on intelligent materials, and it is almost a year and a quarter since a report on the subject was summarized. In the meantime, international workshops were held, and more is expected from forum activities concerning intelligent materials in the future.

The Science and Technology Agency believes that it must pursue R&D in response to the forum activities. After the report mentioned above was presented, efforts have been made to budget for intelligent structural materials, primarily by the National Research Institute of Metals and the National Institute for Research of Inorganic Materials. The Agency intends to go forward with a broad R&D program while utilizing the Expenses for Promotion of Science and Technology.

What about perspectives and expectations in the area of material development policy? A policy naturally is related to a planned system and budget, but does this apply to intelligent materials? It is difficult simply to categorize intelligent materials as basic, applied, or developmental research. All of these categories may apply. This is presumably because R&D follows a concept. Therefore, policy-based guidance may achieve good effects.

If these two national institutes form a project, if R&D for intelligent materials is promoted within the "Sakigake 21" project, and if the project is established on the basis of the future Expenses for Promotion of Science and Technology, it can be expected that the scale of the total budget in two or three years will be about ¥700,000 million. It also is expected that a wider research system featuring cooperation with the universities and the private sector will be structured around this core.

Design of Intelligent Molecular Materials

916C0044C Tokyo SENTAN ZAIRYO NO SHIN CHORYU SYMPOSIUM in Japanese 28 May 91
p 34

[Article by T. Miwa, et al., Tokyo Institute of Technology]

[Text] 1. Introduction

The basic design concept for intelligent materials is to integrate in them the sensor function (information accepting function), processor function (information processing function) and effector function. Therefore, it is expected that intelligent materials will be achieved in various hierarchies from ultramicro-molecular level, to the macroscale.

In organisms, the activity of functional proteins, such as enzymes, are controlled by an extremely clever molecular mechanism. A receptor that exists on the outside surface of the cell membrane and that recognizes as well as receives information molecules, such as a hormone, for example, propagates information by cooperating with enzymes including protein kinase and (adenylcyclase) and activating them. Such an aggregating system presents a good model of an intelligent material intrinsic to molecules.

This study is aimed at creating an intelligent material intrinsic to molecules that will be capable of offering information by hybridizing one protein to provide it with an information receiving function, and another to provide it with an effector function (Figure 1).

This study used calmodulin (CaM) as a protein with an information receiving function. CaM allows Ca^{2+} to effect a structural change in cells, thereby functionally controlling various enzymes and structural proteins CaM is a functional protein with a relatively simple structure that is capable of controlling various functions, and it is useful as an intelligent molecular material.

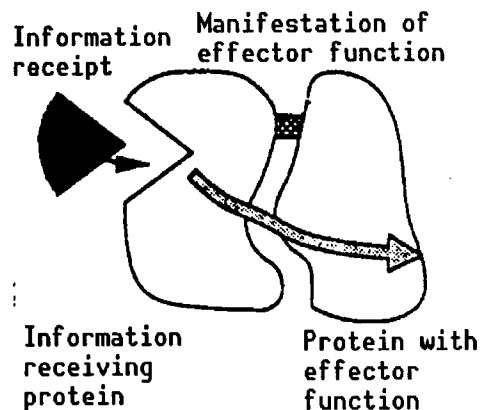

Figure 1. Concept of Intelligent Molecular Material

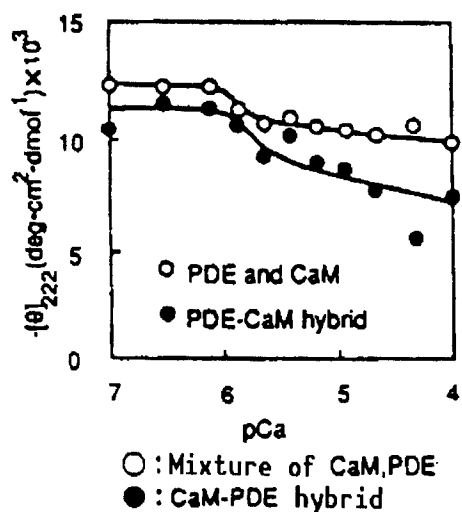

Figure 2. Structural Change in Ca^{2+} of Calmodulin Phosphodiesterase Hybrid (Change in $[\theta]_{222}$ with CD spectrum was measured.)

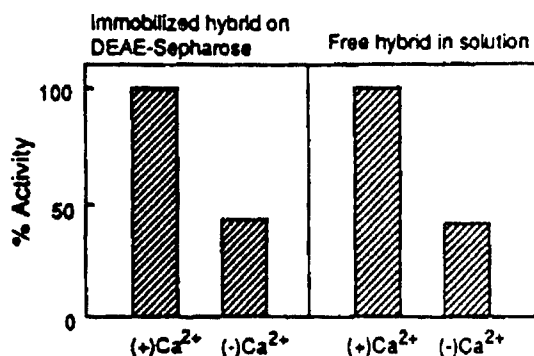

Figure 3. Comparison of Activity of Solidified Hybrid and Unsolidified Hybrid

Further, phosphodiesterase (PDE) was hybridized as a protein with an effector function. PDE is representative of those enzymes activated by CaM. It decomposes cAMP in the information system in cells, producing AMP.

Table 1. Control of Activity of Calmodulin Phosphodiesterase Hybrid by Ca^{2+}

Condition	Performance as specific activity ($\text{mU} \cdot \text{mg}^{-1}$ PDE)		
	Native PDE	CaM-PDE hybrid	
		EDC	SPDP
EGTA (1 mM)	12 ± 5	34 ± 4	4 ± 1
CaCl_2 (1 mM)	18 ± 4	86 ± 0	4 ± 1
EGTA (1 mM), CaM*	10 ± 5	32 ± 5	—
CaCl_2 (1 mM), CaM*	180 ± 30	86 ± 12	—

* Equimolar amount of CaM has added to the native PDE solution and the hybrid solution.

New Drug Release System Utilizing Complex Reaction of Polymers

916C0044D Tokyo SENTAN ZAIRYO NO SHIN CHORYU SYMPOSIUM in Japanese 28 May 91
p 35

[Article by S. Kitano, et al., School of Basic Engineering, Science University of Tokyo, and M. Yokoyama, et al., Medical Engineering Laboratory, Tokyo Women's Medical College]

[Text] Introduction

In recent years, the development of intelligence-oriented preparations has been catching attention. This involves including a sensor region for receiving external signals in a molecular device and controlling drug release according to structural changes in the device itself.

This study is aimed at developing a system capable of administrating an optimum dose of insulin according to changes in glucose concentration. The system also assesses a boric acid group that forms a reversible covalent bond with a compound containing a multivalent hydroxyl group as a glucose sensor region. As shown in Figure 1, a complex polymer formed by a new polymeric material that includes a boric acid group and a polymeric compound possessing diol unit, such as polyvinyl alcohol, seems to become dissociated due to the presence of glucose.

This study analyzed complex polymer formation-dissociation behavior by measuring the viscosity of a solution. This is a basic study aimed at developing a new drug release device that will utilize such a glucose responsive polymer complex.

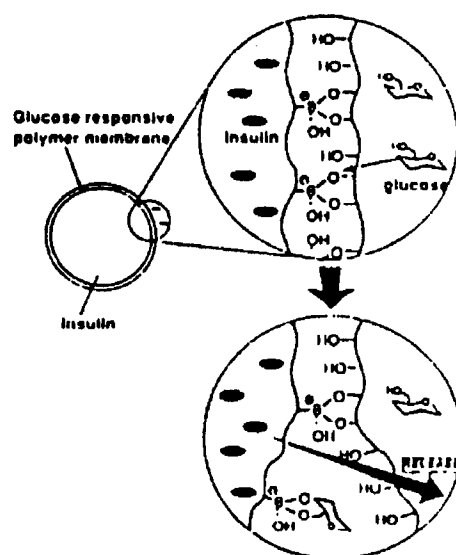

Figure 1. Insulin Release Mechanism From Glucose Responsive Polymer Membrane

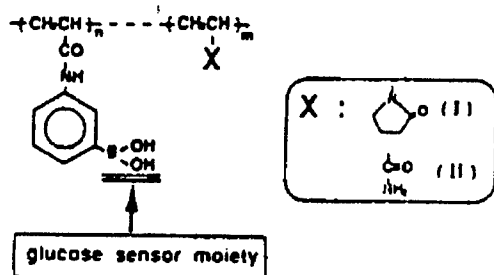

Figure 2. Structural Formula of Poly(NVP-co-PBA)(I) and Poly(AAm-co-PBA)(II)

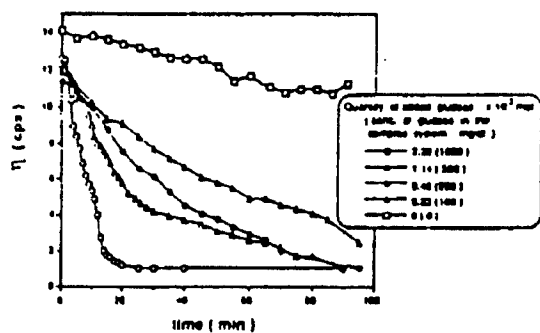

Figure 4. Effect of Amount of Added Glucose on Viscosity of PVA(25500)/Poly(NVP-co-PBA) complex system
In this system, the complex solution consists 3.4×10^{-5} mol of monomeric unit of PVA and 1.6×10^{-4} mol of $-B(OH)_2$ group.

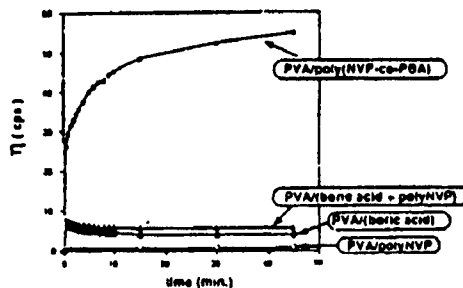

Figure 3. Time Dependence of Viscosity of PVA(88000)/Poly(NVP)-co-PBA(●), PVA(88000)/(Boric Acid + PolyNP)(●) PVA(88000)/Boric Acid(●) and PVA(88000)/PolyNVP(o) Complex System

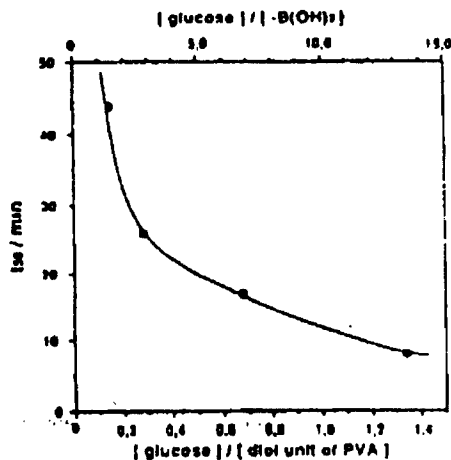

Figure 5. Effect of Molar Ratio of Glucose to Diol Unit of PVA and $-B(OH)_2$ Group in PVA (2550)/Poly (NVP)-co-PBA) Complex System on Half Time

Analysis of Temperature Responsive Drug Release

916C0044E Tokyo SENTAN ZAIRYO NO SHIN CHORYU SYMPOSIUM in Japanese 28 May 91
p 36

[Article by H. Kamitono, et al., Sophia University, and M. Okano, et al.,
Tokyo Women's Medical College]

[Text] Introduction

In recent years we have been awaiting the development of an automatic control system that can sense changes in external environments and automatically provide on-off drug release control. Aiming for a drug release system that will indicate OFF at a low temperature and ON at a high temperature, the authors assessed, as drug carrier to effect the system, an interphreatic network (IPN) consisting of polyacrylamide (PAAm) and polyacrylic acid (PAAc). The latter shows low temperature contraction while the former shows high temperature swelling in response to temperature change.

PAAm and PAAc have properties that enable them to form an insoluble complex polymer through hydrogen bonds at low temperatures (Figure 1), and to allow the hydrogen bonds to be cut and the complex to become dissociated so that it dissolves at high temperatures. This article studied swelling and contracting behavior following temperature changes in this IPN together with the drug release mechanism.

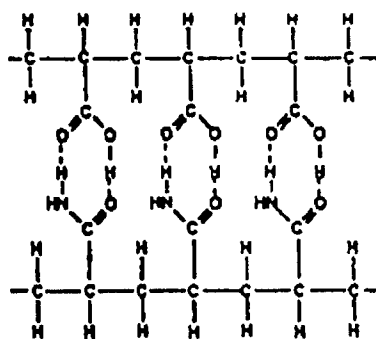

Figure 1. Complex Polymer Formation Between Polyacrylamide and Poly(acrylic acid) by Hydrogen Bonding

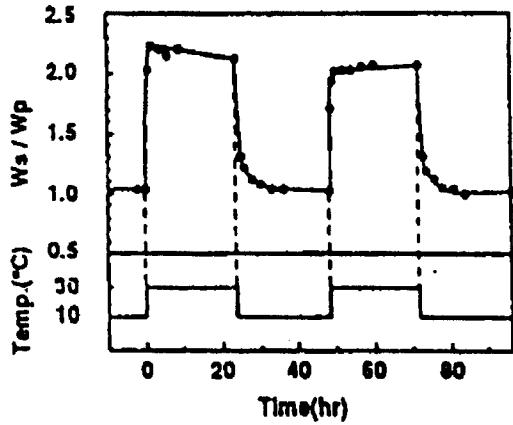

Figure 2. Reversible Swelling Change of IPN-20 in Response to Stepwise Temperature Change Between 10°C and 30°C in Distilled Water

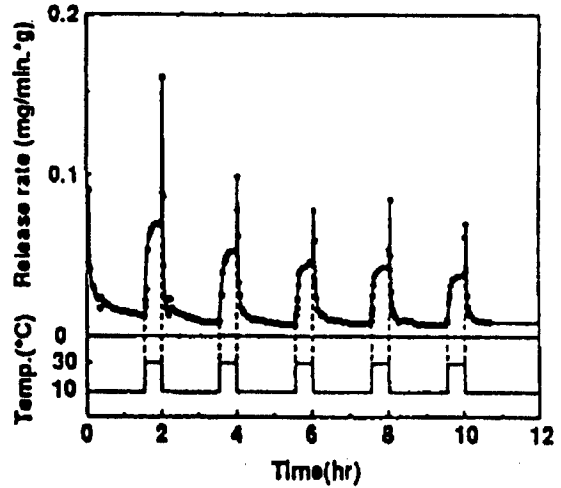

Figure 3. Release Rate Change of Drug From IPN-20 in Response to Stepwise Temperature Change Between 10°C and 30°C in Distilled Water

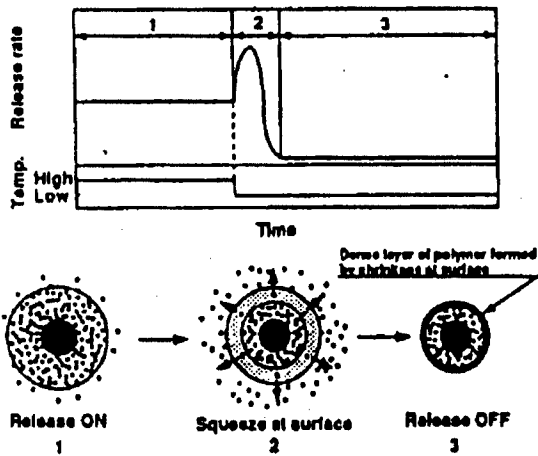

Figure 4. Release "Off" Mechanism of IPN

New Glucose Responsive Insulin Release Gel

916C0044F Tokyo SENTAN ZAIRYO NO SHIN CHORYU SYMPOSIUM in Japanese 28 May 91
p 37

[Article by T. Shiino, International Biomaterial Science Center; Y. Koyama, Life Research Institute; K. Kataoka, School of Basic Engineering, Science University of Tokyo; and M. Yokoyama, et al., Tokyo Women's Medical College]

[Text] Introduction

It is extremely important to develop an insulin release control system that is responsive to concentrations of glucose as a step toward curing insulin dependent diabetics.

It is known that a boric acid group will form a reversible covalent bond with a polyhydric hydroxyl group, a compound of which causes a substitutional reaction. This study is aimed at making a glucose concentration responsive insulin release device utilizing this substitutional reaction.

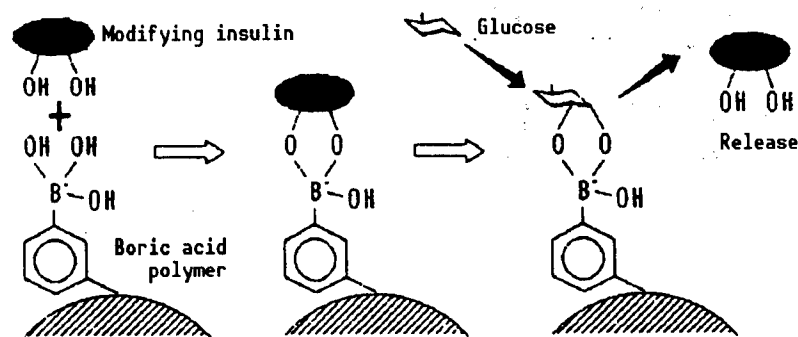

Figure 1. Mechanism of Glucose Concentration Responsive Insulin Release System

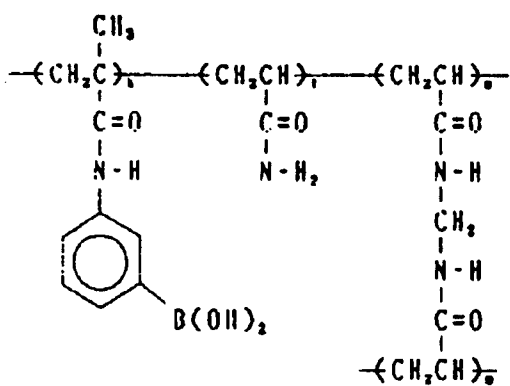

Figure 2. Structural Formula of Polymer

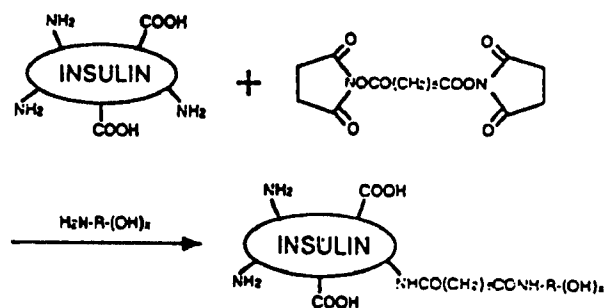

Figure 3. Schematic Structure of Insulin Hydroxylation

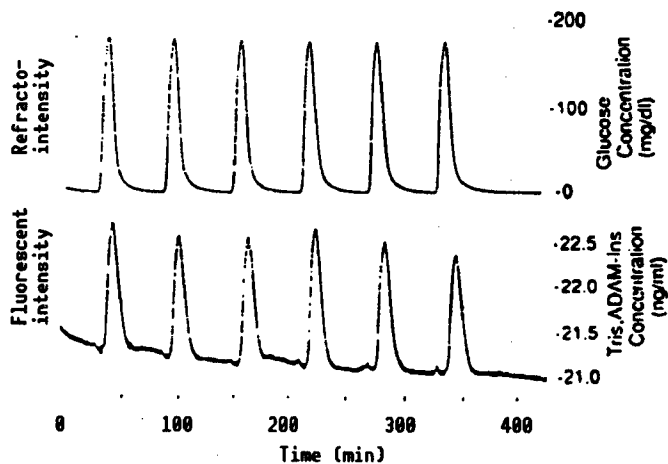

Figure 4. Release of Tris,ADAM-Insulin From Boronic Acid Gel

Protein Device To Release Insulin in Response to Glucose

916C0044G Tokyo SENTAN ZAIRYO NO SHIN CHORYU SYMPOSIUM in Japanese 28 May 91
p 38

[Article by Y. Itoh, et al., Kyoto University]

[Text] Introduction

Experiments aimed at synthesizing new proteins using gene manipulation technology have been actively carried out over the last several years. Most of the new proteins synthesized, however, have had their existing functions, such as providing heat resistance, conversion, and fusion of substrate specificity, expanded.

This article describes results of a series of experiments aimed at providing drug delivery (a system to release insulin in response to glucose), a totally new ability, by modifying proteins. To date, attempts to cure diabetes have included the creation of a hybrid artificial pancreas where the islets of Langerhans are covered with semipermeable membrane capsules, a mechanical micromachine with a glucose sensor and insulin injection functions, and chemical systems using an exchange reaction and a stimulus responsive polymeric membrane.

The authors, however, have contrived a device using proteins, as shown in Figure 1. With this device, when the concentration of glucose increases, glucose oxidase oxidizes it, thereby deoxidizing the disulfide bond and releasing insulin.

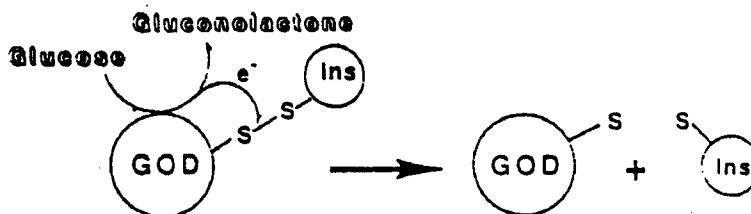

Figure 1. Operating Principle of Protein Device

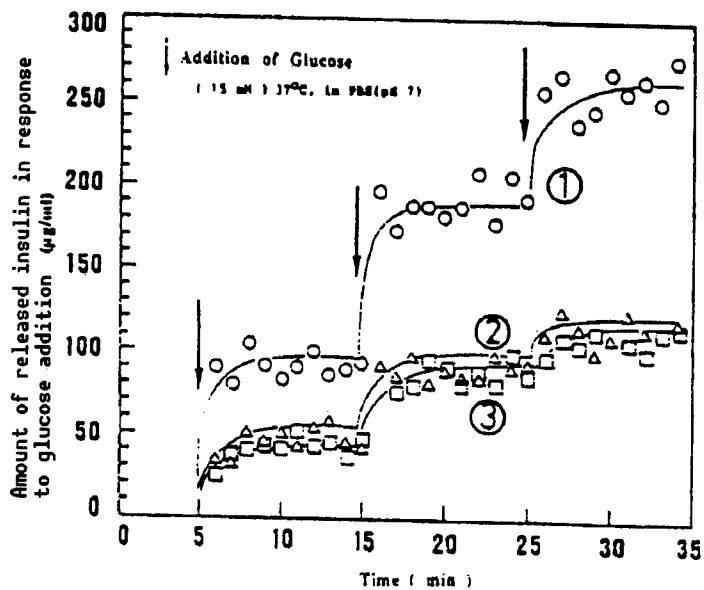

Figure 2. Insulin Release From Protein Device

Insulin derivatives	Relative biological activity	
	0.5	1.0
$\text{HOOC}-\text{Insulin}-\text{NH}_2$		
$\text{MeOC}-\text{Insulin}-\text{NH}_2$		
$\text{MeOC}-\text{Insulin}-\text{NHCO}-\text{Glu}-\text{HOOC}$		
$\text{MeOC}-\text{Insulin}-\text{NHCO}-\text{Glu}-\text{NHCO}$		

Figure 3. Biological Activity for Modifying or Releasing Insulin

Intelligent Materials Based on Responsive Polymer, Biocatalyst

916C0044H Tokyo SENTAN ZAIRYO NO SHIN CHORYU SYMPOSIUM in Japanese 28 May 91
p 39

[Article by H. Ichijo, et al., Research Institute for Polymers and Textiles]

[Text] Introduction

The authors have continuously studied the immobilization of heat responsive polymers and biocatalysts. They have prepared N-isopropyl acrylaide (NIPAAm) and polyvinyl methyl ether (PVME) gels, observed and measured the thermal transition behavior and dynamic properties of the gels, applied them in energy saving separation and dehydration processes, and structured article muscle models. They also have developed two types of polyvinyl alcohol (PVA) carriers (microfibril and photosensitive PVA), followed by ion adsorption to fiber surfaces and the immobilization of biocatalysts by including them in the gel interior. Based on the results of these studies, they are going forward with research into the configuration of intelligent materials by combining a stimulus responsive polymer and enzymes.

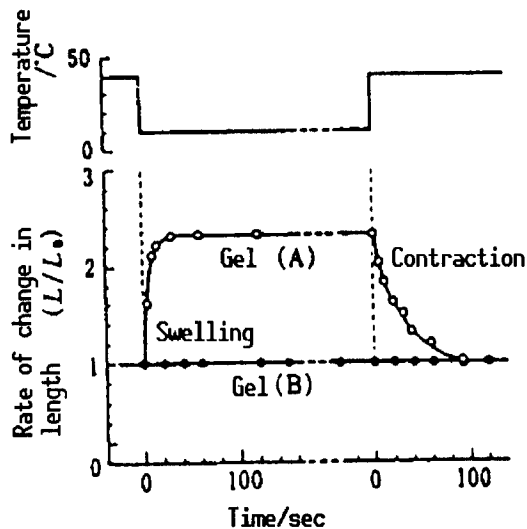

Figure 1. Thermal Responsiveness of PVME Gel

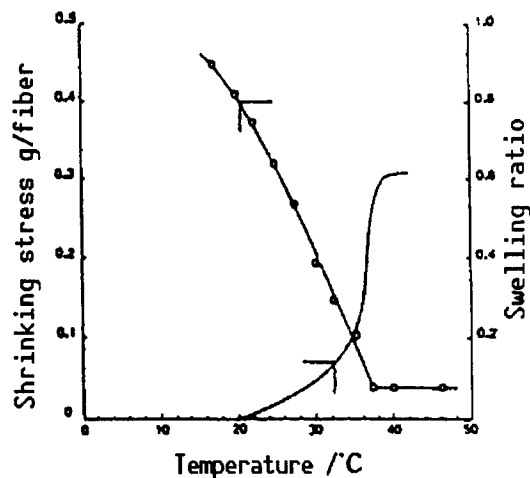

Figure 2. Thermal Contraction Stress and Swelling Rate of PVME Fiber

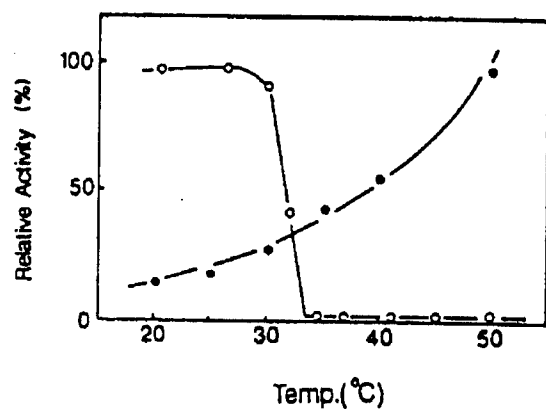

Figure 3. Temperature Dependency of Enzyme Activity Included by Thermal Responsive Polymer
(o: immobilization; •: liberation)

High-Efficiency Chemomechanical Materials

916C0044I Tokyo SENTAN ZAIRYO NO SHIN CHORYU SYMPOSIUM in Japanese 28 May 91
p 40

[Article by H. Okuzaki, et al., School of General Education, Ibaraki University]

[Text] Introduction

A polymeric gel can have a water content virtually equivalent to that of a biosystem, and also provides a high level of flexibility. Causing morphological changes to this substance using an electrical stimulus is very interesting as a chemomechanical reaction that offers excellent responsiveness and controllability. To date, the authors have found that a polymeric electrolytic gel contracts by impressing voltage, and we have studied the chemomechanical characteristics of this gel. To achieve a chemomechanical system with a higher degree of efficiency seems to require control of the gel's high-order structure by using an electric field. It has been made clear that when an electric field is impressed into a polymeric electrolytic gel in a micelle solution, it is deformed with a high degree of efficiency. The authors found that this behavior, unlike the inorganic salt (Na_2SO_4) solution, is unique to a micelle solution.

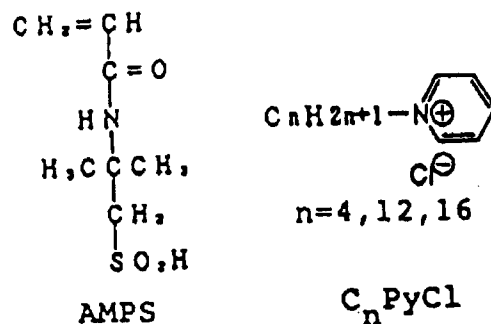

Figure 1. Structure of AMPS
and C_nPyCl

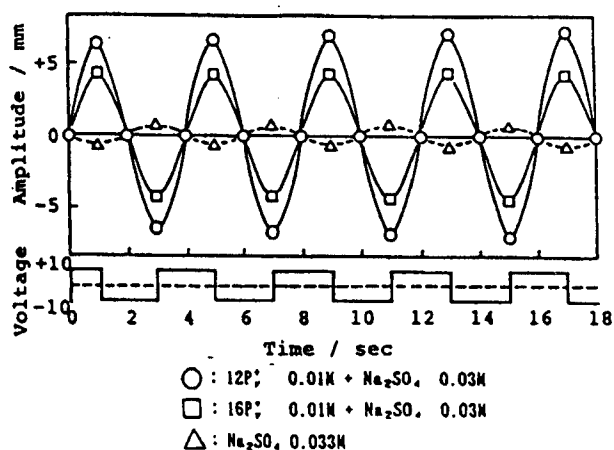

Figure 2. Electro-driven Chemomechanical Responses of Poly (AMPS) Gel in the Presence of C_nPyCl

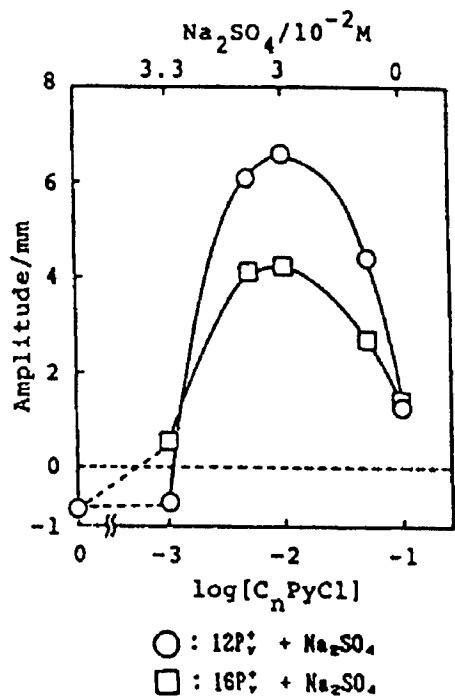

Figure 3. Dependence of Amplitude of Bending on the Surfactant Concentration

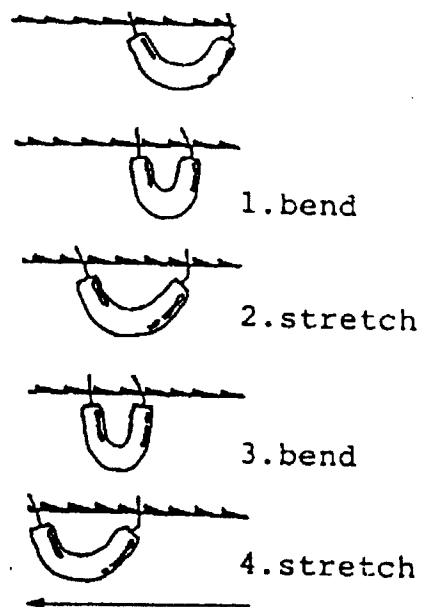

Figure 4. Scheme of Walking Gel-Looper

Grafted Porous Membrane With Responsive Pores

916C0044J Tokyo SENTAN ZAIRYO NO SHIN CHORYU SYMPOSIUM in Japanese 28 May 91
p 41

[Article by Y. Itoh, Kyoto University]

[Text] Introduction

It has been reported by Nagata that a polyacrylic acid grafted porous membrane can control water permeability in response to pH, and subsequently various pH stimulus responsive systems have been contrived. The author has demonstrated previously that a combination of such a pH responsive system, a glucose responsive enzyme, and glucose oxidase makes it possible to create a system (artificial pancreas) that will release insulin in response to glucose concentrations as shown in Figure 1. This article shows that responsiveness can be changed by varying the conditions for grafting a polymeric electrolyte with the stimulus responsive function to a porous membrane, and that substance permeability can be controlled by oxidation and reduction as well as by pH response.

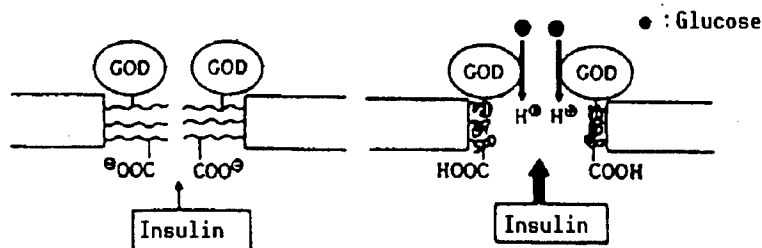

Figure 1. Typical Figure of Glucose Responsive Insulin Release by a System With Glucose Oxidase (GOD) Polyacrylic Acid Grafted to Surface

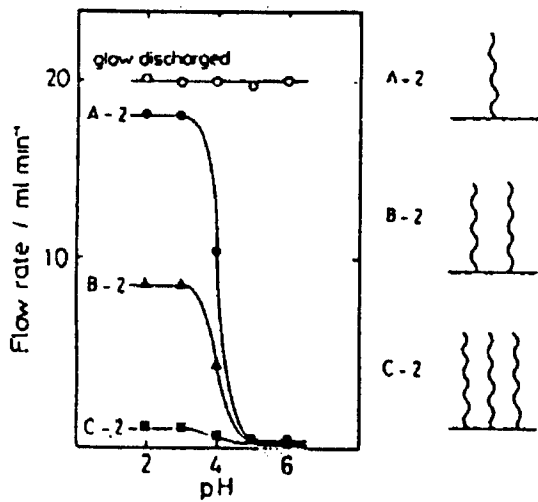

Figure 2. pH Dependency of Grafted Membrane's Permeability (Influence of graft density)

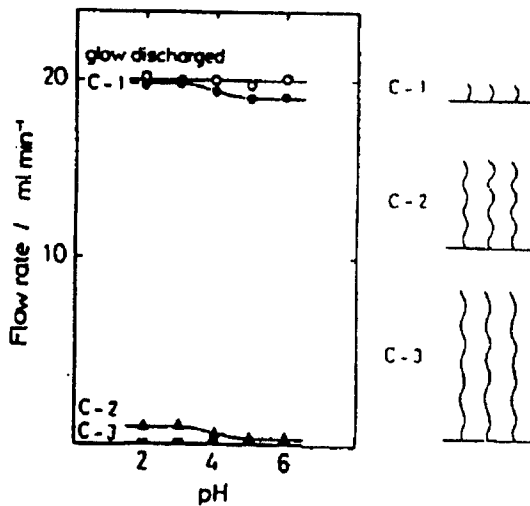

Figure 3. pH Dependency of Grafted Membrane's Permeability (Influence of graft chain length)

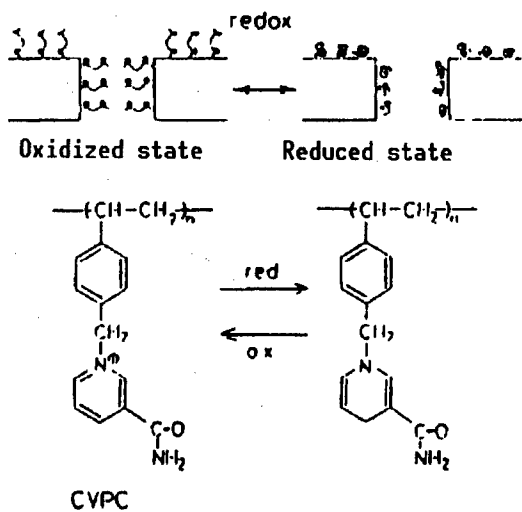

Figure 4. Oxidation/Reduction Responsive Grafted Membrane

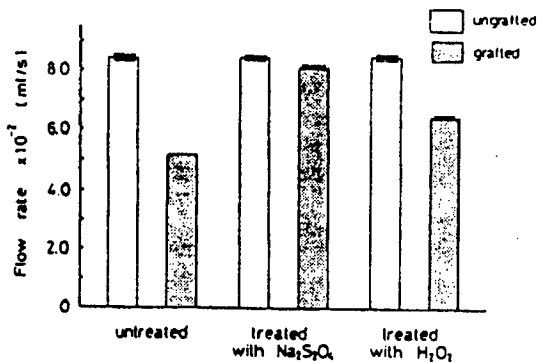

Figure 5. Change in CVPC Grafted Membrane's Oxidation/Reduction Responsibility and Permeability

Design of Intelligent LB Membrane Oscillating Laser Beam

916C0044K Tokyo SENTAN ZAIRYO NO SHIN CHORYU SYMPOSIUM in Japanese 28 May 91
p 42

[Article by S. Miyata, et al., Tokyo University of Agriculture and Technology]

[Text] Introduction

There have been growing demands for compact laser systems with oscillating visible light in recent years. In order to meet these needs, attempts to shorten the semiconductor laser wavelength have been energetically made. However, it is very difficult at present to oscillate wavelengths of 600 nm or less. Another method for shortening the wavelength is to combine a semiconductor laser and a nonlinear optical device. Cerenkov radiation-type nonlinear optical devices using LiNbO_3 already have been commercialized. However, because the pattern of the outgoing beam from the waveguide forms a half-moon, they need to use a specific acousicon lens for convergence, and, furthermore, they are very expensive. The authors will control the structure of an LB membrane with rare earth element ions (Eu^{3+} , Nd^{3+} , etc.) to make it asymmetric, and will describe the cavity configuration and design of a membrane laser by combining electric field emission organic membranes.

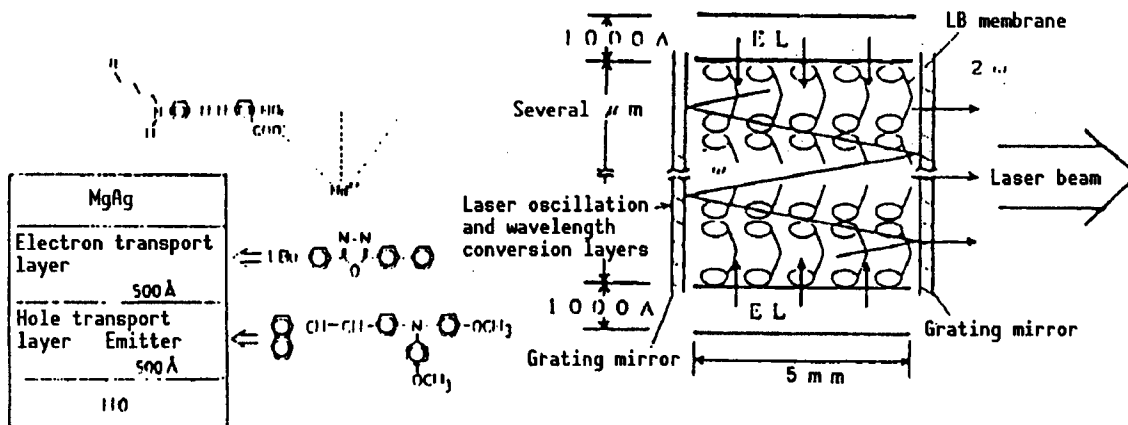

Figure 1.

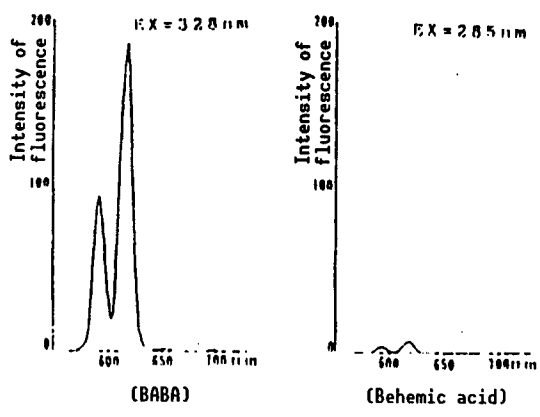

Figure 2.

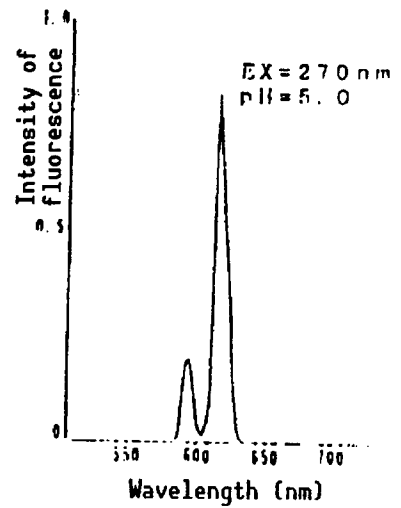

Figure 3.

Table 1.

pH	Intensity of florescence (a.u.)
4.5	1.19
5.0	1.20
5.5	0.50
6.0	0.42

When pH=5.5, the intensity of the fluorescence of arachidic acid is 0.03.

Potential for Intelligence Manifestation in Ceramic Sensors

916C0044L Tokyo SENTAN ZAIRYO NO SHIN CHORYU SYMPOSIUM in Japanese 28 May 91
p 43

[Article by Y. Nakamura, et al., Advanced Science and Technology Research Center, University of Tokyo]

[Text] Introduction

Since the chemical stability and environmental resistance of ceramic materials are well known, research into ceramic sensors is necessary to create devices for use in production control and environmental protection that can be actuated under hazardous environments humans cannot withstand. Many study examples involving ceramic sensors, such as a humidity sensor that recognizes vapor and molecules in a vapor phase, and a gas sensor, are available. Generally speaking, however, a ceramic sensor merely monitors changes in the amount of oxygen adsorption following a gas combustion reaction on oxide surfaces. Therefore, to provide a gas sensor device with the ability to detect only specific molecules requires that the sensor device itself be provided with intelligence to enable it to recognize specific molecules.

Since a gas sensor mechanism is related to the chemical reaction of gas molecules on the sensor surface, it can be said that control of the reaction is necessary for the manifestation of the particular form of intelligence called the molecule recognizing function. However, it is appropriate to consider that it is difficult to control surface chemical reactions with the current surface reaction technology. Also, combining materials made of substances provided with different functions should be an effective way to achieve the manifestation of intelligence.

This study, which is aimed at providing a ceramic sensor with a molecule recognizing function, considers the potential of applying an electron migration phenomenon caused by setting a specific

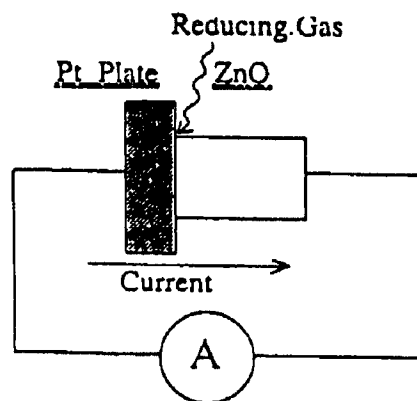

Figure 1. Precious Metal-Zinc Oxide (ZnO) Contact System

reaction field called ceramic heterocontact. The authors have contrived a ceramic sensor with the molecule recognizing function, which is the base of intelligent chemical sensors.

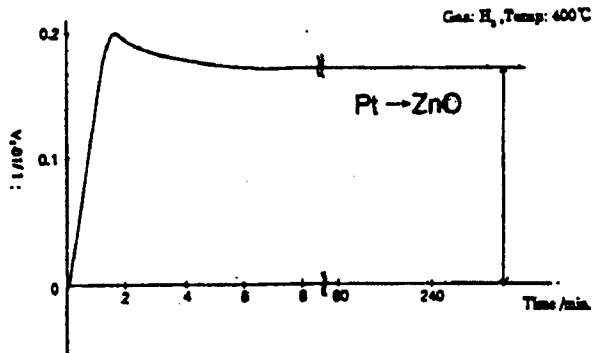

Figure 2. Short-Circuit Current Generated in Pt-ZnO Interface (Pt→ZnO is positive)

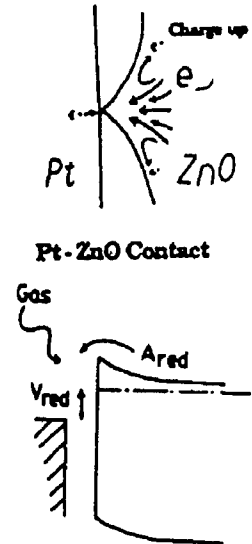

Figure 3. Presumed Short-Circuit Current Generating Mechanism

II. Functionally Gradient Materials

Development of Functionally Gradient Materials

916C0044M Tokyo SENTAN ZAIRYO NO SHIN CHORYU SYMPOSIUM in Japanese 28 May 91
pp 59-74

[Article by M. Shinno, National Aerospace Laboratory: "Functionally Gradient Materials Development Project; State of Research Progress in Individual Departments; Reorganization of Database"]

[Text] 1. Challenge to New Space Age

Space planes, represented by the experimental model X-30, which is under development by the National Aero-Space Plane (NASP) project of the United States are in the limelight worldwide. To date, however, research into key thermal conductivity has been carried out in the space-related advanced nations. With a number of technological problems remaining to be solved before the creation of a space plane, however, these problems have been discussed repeatedly in the "Space Plane Workshop," an advisory organization to the director general of the Research and Development Bureau, in order to formulate concrete measures to cope with them. As part of the developmental trend survey for next-generation space planes, MITI consigned the "space plane developmental trend survey" to the Society of Japanese Aerospace Companies, Inc., summarizing survey reports. In these reports it is stated that ultrahigh heat-resistant materials are one of the most important key technologies for both the airframe and propulsion systems.

A space plane uses a new type of air suction engine. Thus, its flight route to aerosphere escape is quite different from that of a rocket. Unlike a rocket, a space plane requires a long hypersonic flight in the atmosphere for acceleration. This causes the airframe and engines to become heated to ultrahigh temperatures, so they must be cooled using the space plane's liquid hydrogen fuel. Therefore, large thermal stresses are caused by the remarkable temperature difference between the exterior of the airframe or the interior of the combustion chamber, and the cooled surface on the other side. Furthermore, a space plane must be very durable in order to withstand several hundreds of flights, and it is impossible to use existing materials for its members. Thus, to create a space plane, it is essential to develop thermal insulating ultrahigh heat-resistant materials that are capable of withstanding environments where they are exposed to ultrahigh temperatures and where there is an

extremely large internal temperature difference. The U.S. NASP project also regards the development of such materials as an important theme.

To meet such demands, a totally new concept, that of "functionally gradient materials," has been created in Japan.

2. Concept of functionally gradient materials²

Figure 1 presents a typical conceptual view of a functionally gradient material using the example of thermal stress relaxation. The concept involves providing the surface in contact with gas heated to several thousands of degrees with the requisite heat resistance by arranging ceramics on the surface to effect heat conductivity, providing the necessary mechanical strength by arranging a metallic material, and positively relaxing thermal stresses by synthesizing materials so that their composition, structure, and the pattern of holes between the two are optimized.

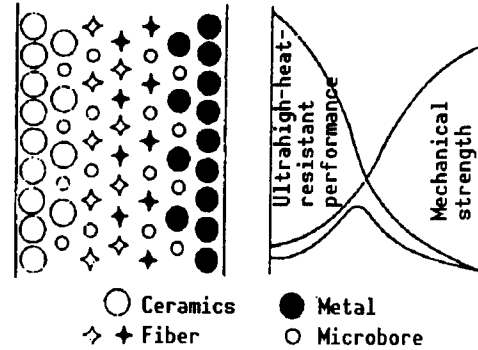

Figure 1. Conceptual View of Functionally Gradient Materials

The term functionally gradient material (FGM) is given to materials that have manifested various functions by controlling the distribution of the components of the materials (metals, ceramics, plastics, fibers, cavities, etc.) continuously and properly according to environments where they are to be used. It is expected that the concept of functionally gradient materials can be used to solve many problems resulting from interfaces. At the same time, gradient composition itself has infinite potential as a means whereby a material can be made to display new functions.

3. Functionally Gradient Materials Development Project

A project known as "Research Into Key Technologies for the Development of Functionally Gradient Materials for Relaxing Thermal Stresses," which is aimed at the development of ultrahigh heat-resistant materials has been under way since FY87. It is funded under the Expenses for the Promotion of Science and Technology.² The research system comprises as shown in Figure 2, three departments, one for material design, a second for structural control, and another for characteristics evaluation. The research is aimed at establishing key technologies for creating functionally

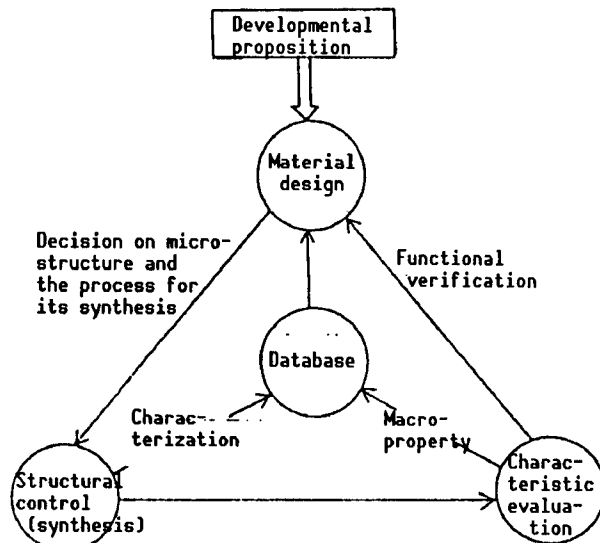

Figure 2. Research System for Functionally Gradient Materials

gradient materials that can be used in environments where the maximum surface temperature on the high temperature side is on the order of 2000 K, while the maximum temperature gap from the low temperature side is on the order of 1000 K. The research is to be conducted over a 5-year period, from FY87 to FY91.

The design department has produced a primary design using data on homogeneous mixed materials and various rules of thumb. Using this design, the structural control department has successfully synthesized miniature specimens (diameter = 30 mm) of functionally gradient materials made of various materials. The evaluation department, meanwhile, has carried out a series of characteristics evaluation tests on these specimens, collecting data on various properties. The data obtained by the three departments will be added to the FGM database at the National Aerospace Laboratory, and it is planned that the three departments will create functionally gradient materials through organic cooperation based on the use of this database.

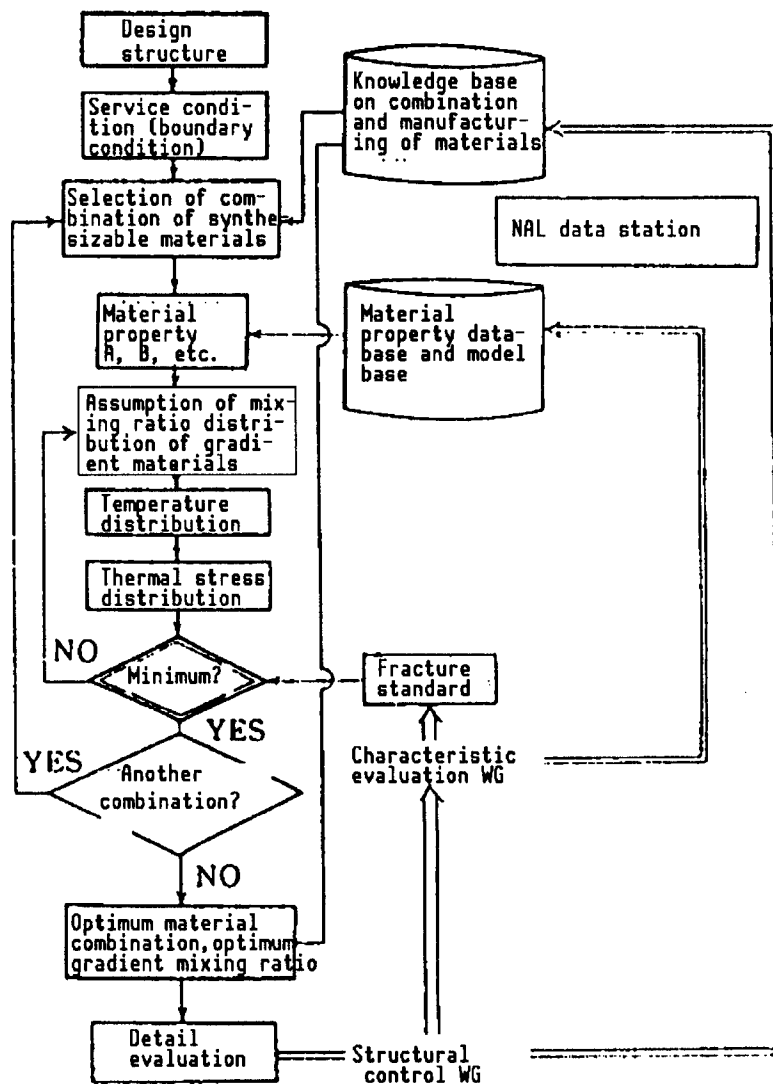

Figure 3. Reverse Design Flow System in Design of Functionally Gradient Materials

4. Status of Progress in Material Design Department

The material design department selects combinations of materials and the methods for synthesis, based on material specifications including shapes and use conditions, in accordance with the reverse design flow system shown in Figure 3. It estimates the distribution of property values in the interior of materials and the distribution of microtextures. Using this, it calculates the distribution of temperature and thermal stresses under use conditions, thereby determining whether the calculated results meet the specifications. Figures 4 and 5 show the effects of thermal stress relaxation when functionally gradient materials are applied to a rocket.

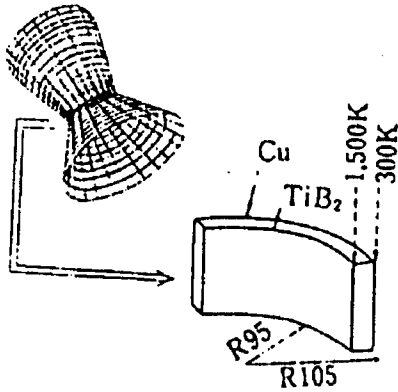

Figure 4. Infinite Cylinder Analysis Model of Rocket Combustor Made of Functionally Gradient Materials

Figure 6 is an example of the application of this system to a space plane. It shows the design results when the airframe surface is heated to 2000 K and its interior is cooled to 1000 K by active cooling.⁴ A material combination of SiC and C under a test manufacturing study by CVD was employed. There are two types of evaluation standards for the level of optimization that can be introduced into the current system, the thermal stress minimization method and the gravity minimization method. The mixing ratios for the distribution of SiC-C in the example cited in this article were designed using the latter.^{3,4}

5. Status of Progress in Research in Structural Control Department

In the structural control department, many organizations are promoting research using their own synthesis methods, and each has succeeded in synthesizing samples of functionally gradient materials 30 mm in diameter.

First, let me describe the physicochemical evaporation fusion method.⁵ This method involves the formation, with a C/C composite as the base material, of a TiC-Ti gradient composition layer and a junction layer with metallic structure members on one side, and a C-SiC gradient composition layer to provide heat resistance and oxidation-resistant performance at high temperatures on the other side. The TiC-Ti gradient composition layer was formed by controlling the flow rate of CH₄ gas, which reacts with Ti vapor. This was carried out in an ion plating unit. Meanwhile, the C-SiC gradient composition layer was formed by changing the flow ratio of SiCl₄, a material gas, and CH₄ in a step-shaped manner for a set coating time to achieve chemical vapor deposition. Figure 7(a) is a photograph showing the texture of a C-SiC functionally gradient material coated on a C/C composite. A functionally gradient material that can be joined to metallic structure members and that offers excellent heat and oxidation resistance, with a C/C composite as the

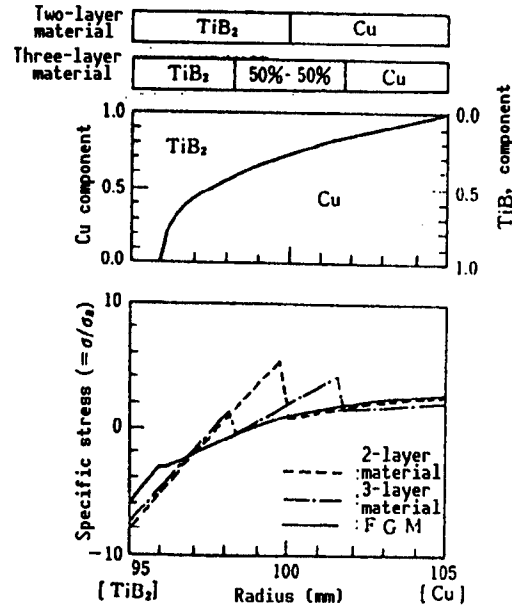
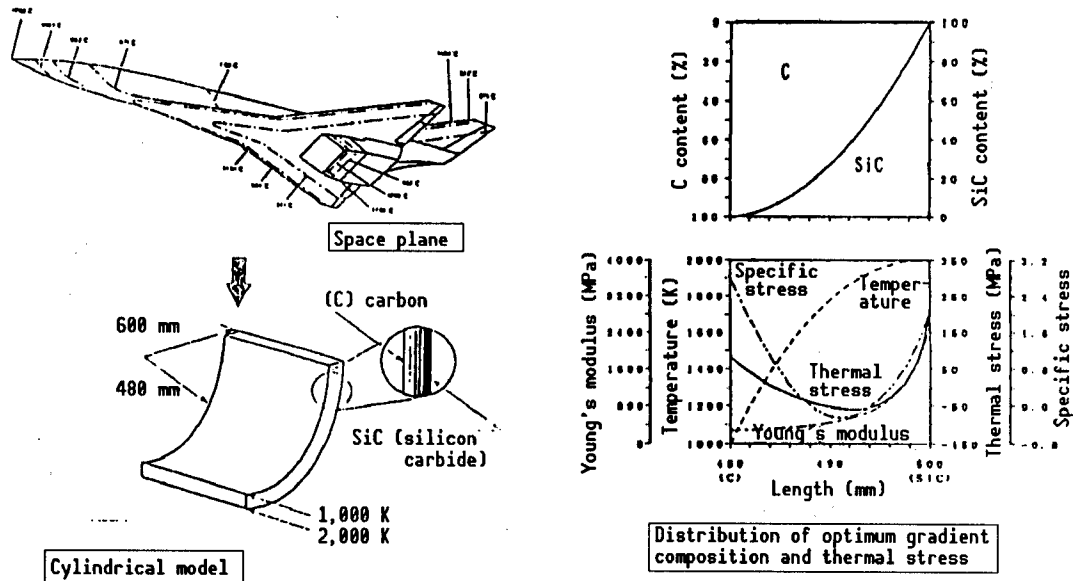

Figure 5. Effect of Thermal Stress Relaxation by Gradient Controlled Materials



(Design example)
Example of designing functionally gradient materials for external airframe wall of a space plane. The temperature of the external walls of the airframe is about 2,000 K, with a temperature difference from the internal surface of more than 1,000 K. The materials combined are SiC and C. The right-hand drawing shows gradient compositional distribution to minimize thermal stress generated in airframe external wall materials.

Figure 6. Examples of Application of Functionally Gradient Materials

functionally gradient layers on either side of a C/C composite. The molecular method, meanwhile, offers a synthesis technique based on the membrane lamination method. This method involves producing slurry by mixing grain-size adjusted ceramics and a metallic powder material, a binder, dispersant, and a plasticizer. Using a vibrating mill, these compositions are combined to form a membrane (greensheet) with a doctor blade. Next, it is defoamed in a vacuum stirring defoaming unit and synthesized to create a functionally gradient material by producing, laminating, and sintering membranes with various mixing ratios. Figure 7(b) shows a photograph of its texture.

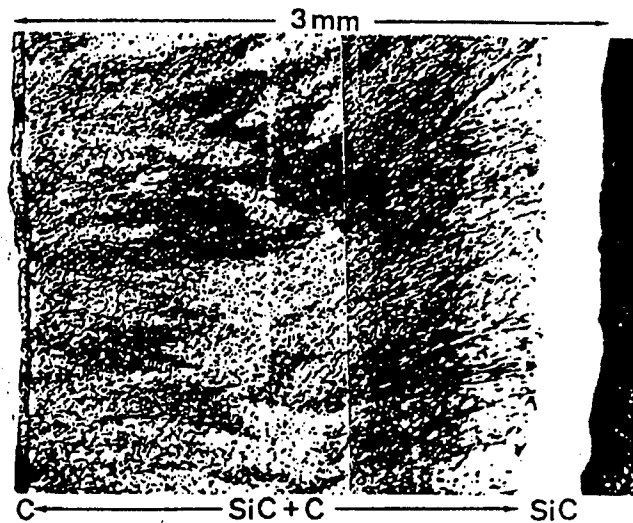

Figure 7(a). Sectional Photograph of C-SiC Functionally Gradient Material Coated on C/C Composite

A thermal spray technique has been established in which a functionally gradient material is synthesized by simultaneously charging ceramic and metallic powders into a plasma jet generated from a plasma gun. The amount and

flow of the powders are precisely controlled by using the pressure reduced plasma spray method.⁷ This technique was made possible by the development of a four-port pressure-reduced simultaneous spray unit that can charge powder into one plasma gun from four directions. Figure 7(c) shows a texture photograph of a functionally gradient material produced by the plasma thermal spray method.

Another approach involves the self-exothermic reaction method.⁸ Here, a hydrostatic compression method has been developed in which the composition of a mixed powder is pre-adjusted and laminated using a technique for slanting, laminating, and filling the powder with an arbitrary composition.

The green compact thus obtained is sealed in a metallic container where it is ignited and synthesized under hydrostatic pressure, thereby simultaneously synthesizing and molding a functionally gradient material from a mixture of a metal and nonmetal. The development of the automatic laminating and filling unit, and the hydrostatic compression method, has made it possible to cope with large and complex-shaped functionally gradient materials.

6. Status of Progress of Research in Characteristics Evaluation Department

The characteristics evaluation department has at its disposal a number of test methods for evaluating everything from basic characteristics to characteristics in actual environments. If established as evaluation techniques, these test methods will play an important role in putting functionally gradient materials to practical use, for example, when introducing them as structural members for space planes.

In the area of heat insulating performance evaluation technology, the high-temperature difference basic evaluation test system shown in Figure 8 has been installed at the National Aerospace Laboratory.⁹ In this system, a thermal flux

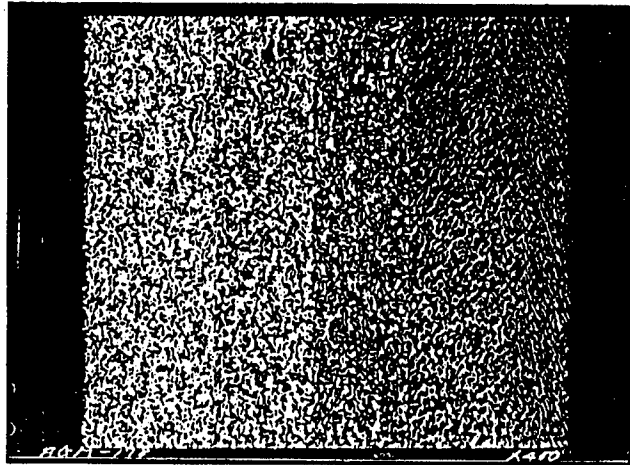
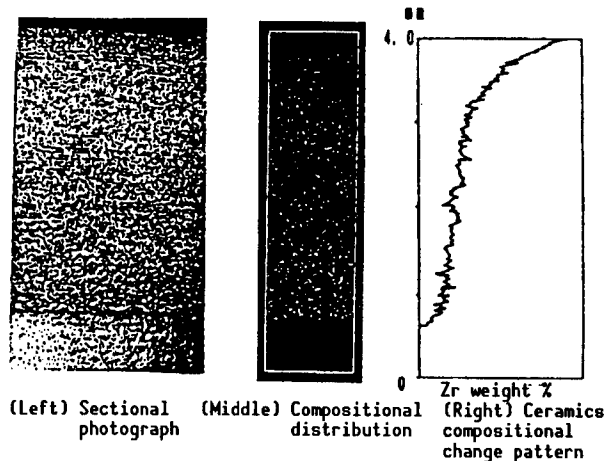

Figure 7(b). Microscopic Photograph of Texture of ZrO_2 -Ni Functionally Gradient Material Formed by the Membrane Laminate Method



Red: Ceramic [published in black and white]
Green: metal

Figure 7(c). Analysis Results of Images of ZrO_2 -NiCr Functionally Gradient Material Produced by Pressure Reduced Plasma Spray Method

with a maximum value of 5 MW/m^2 is applied to the surface of a 30-mm diameter specimen mounted in a vacuum chamber. At the same time, the back of the specimen is cooled with liquid hydrogen or liquid nitrogen, thereby achieving such experimental conditions as a surface temperature of 2000 K and a temperature gap of 1000 K between the surface and the back of the specimen. The system is capable of performing a basic evaluation of heat insulating performance, structural soundness, and thermal fatigue characteristics.

Figure 9 shows the changes in the thermal cycle and the effective thermal conductivity obtained by the system. Figures 10 and 11 are texture photographs of a post test SiC single-layer material and an SiC-FGM material.¹⁰ Based on the results of this high-temperature difference test, tests under various environments simulating the flight conditions of a space plane will be implemented. In the first place, with supersonic turboengines, a high-speed rotation heating field evaluation test will be implemented with a view to applying a functionally gradient material to turbine blades, which rotate fast at high temperatures. In this test, a heavy thermal stress and centrifugal force are

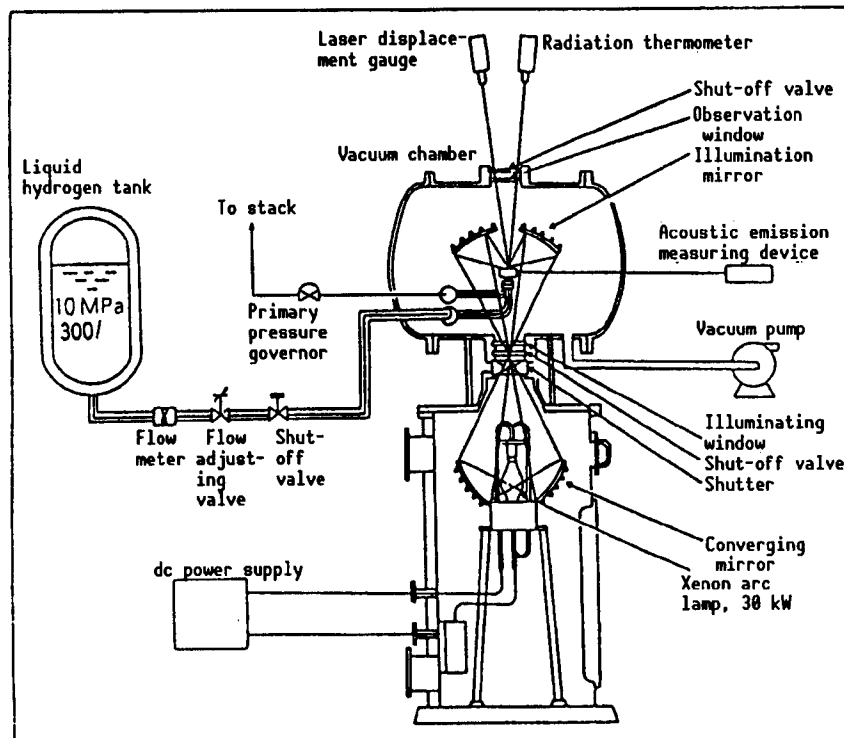

Figure 8. High-Temperature Difference Basic Evaluation Test System

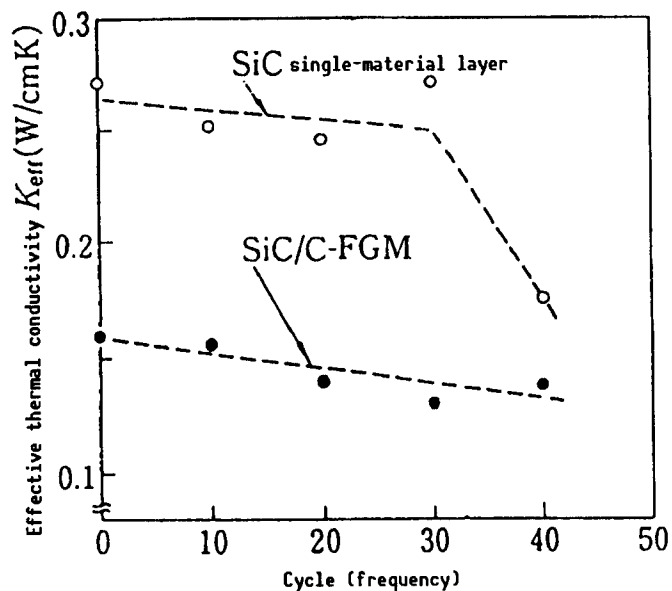

Figure 9. Change in Effective Thermal Conductivity by Heat Cycle

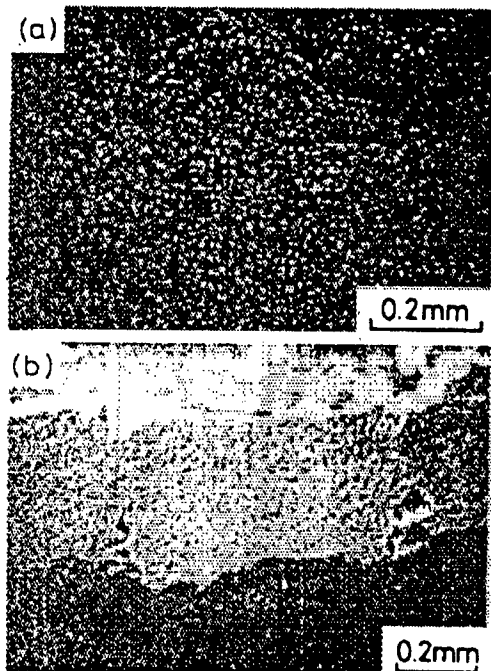

Figure 10. Texture Photograph of SiC Single-Layer Material After High-Temperature Difference Test

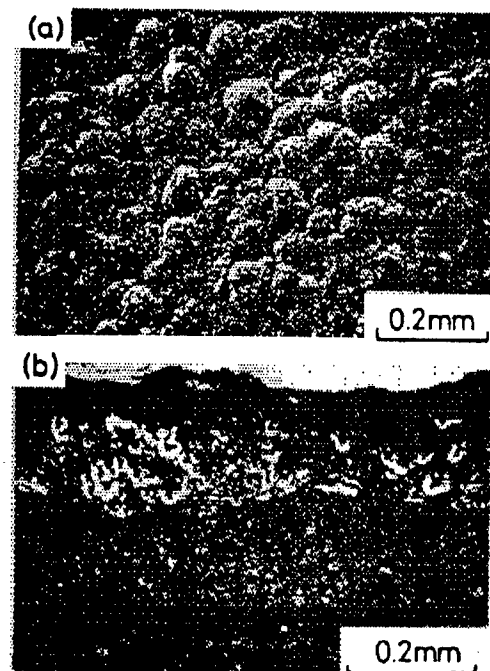

Figure 11. Texture Photograph of SiC/C-FGM After High-Temperature Difference Test

simultaneously loaded to evaluate the heat transfer characteristics, deformation, and the fracture behavior of specimens.

An aerodynamic heating field evaluation test designed to simulate the aerodynamic heating conditions that occur during reentry will be conducted to evaluate a number of factors, including the influence of chemical reactions, including oxidation, on specimens; the shearing stress that results from high-speed flow; the heat resistance of specimens in an air current heated to ultrahigh temperatures (6000 K); and a high Mach number.

In a test using the thermal shock method,¹⁰ the surface of the specimen was locally heated by the CO₂ gas laser oscillating system shown in Figure 12. The relationship between laser output and microcracks was examined, thereby making it possible to evaluate thermal shock resistance. The correlation between these results and the results of the high-temperature difference basic evaluation test is being examined, and analysis of structures simulating this test method is being implemented, thereby raising expectations that a standard thermal shock test method can be established.

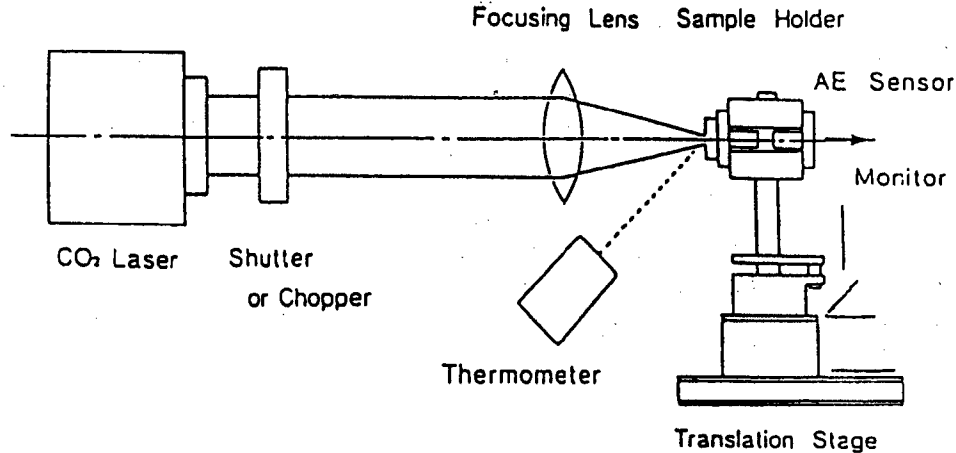

Figure 12. Outline of Thermal Shock Test by Laser Heating

7. Readjustment of Database

It is planned that the data obtained by the three departments will be accumulated in the FGM database at the National Aerospace Laboratory (NAL), and that functionally gradient materials will be completed through the organic cooperation of the three departments, which will draw on this database.

One-way data control centering around the data station at the NAL has been carried out since the initiation of the development program. Reorganization of the database is extremely important in terms of ensuring effective control of the data and information that will provide a basis for the practical use of functionally gradient materials in the future. Furthermore, personal computers at research institutes throughout the nation have been connected to the workstation at the NAL since FY88 in order to create a network to provide direct access to NAL's database. When this database and the network are reorganized, it will be possible to carry out material design using the latest data updated on a real-time basis, and, based on these data, to control material structure in an optimum way. It is expected that this will promote the project more efficiently.

8. Evolution of Developmental Project

As noted above, it has become possible to synthesize miniature specimens of functionally gradient materials. In the project, research in the three departments is currently aimed at synthesizing large functionally gradient materials with complex shapes. Figure 13 shows those areas of a space plane in which large functionally gradient materials are likely to be applied.

The material design department plans to establish a technique for designing functionally gradient materials that also can be used to design complex shapes and three-dimensional gradient of materials, and materials that can be subjected to actual environmental tests. To this end, efforts will be made to carry out nonsteady heat transfer analysis and elasticity and plasticity

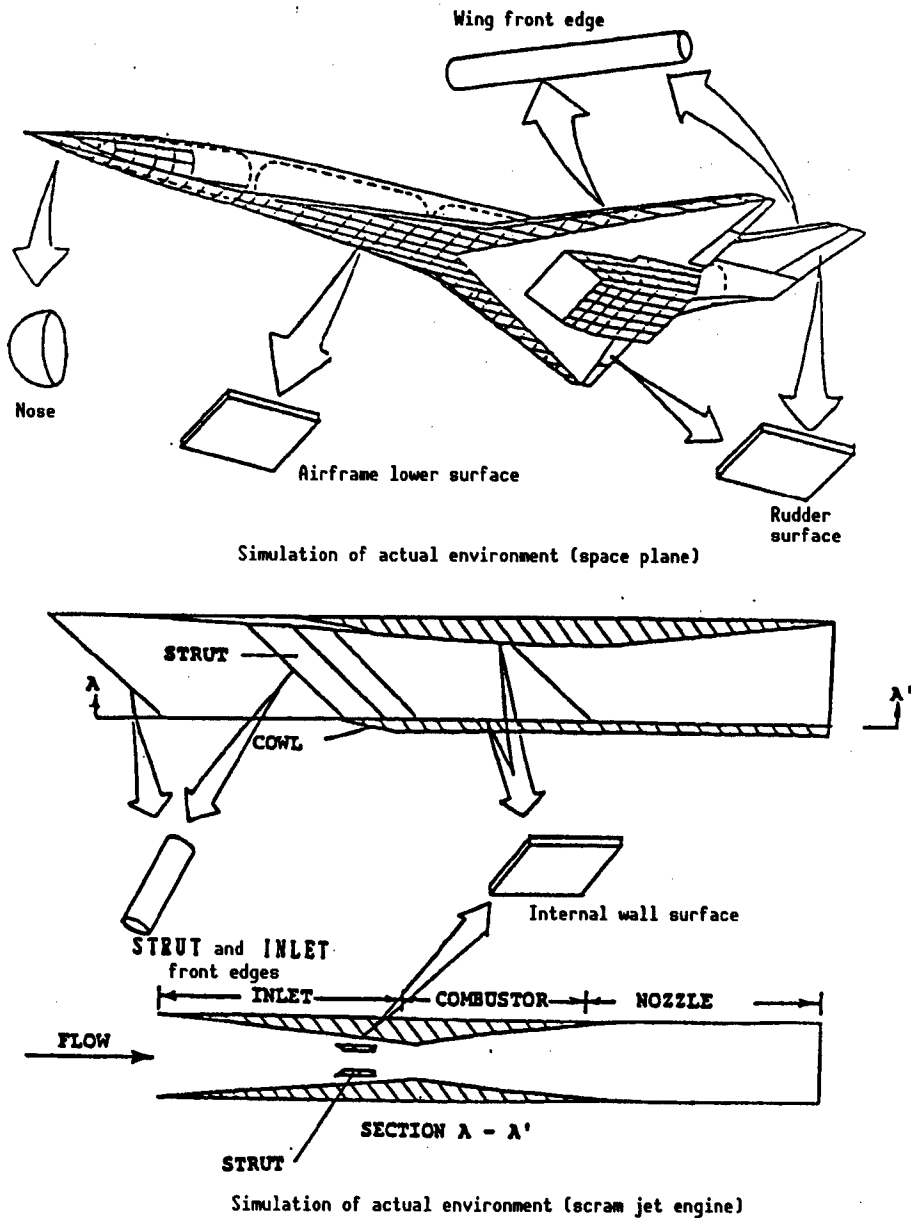

Figure 13. Simulation of Actual Environment

analysis, thereby expanding the database and structuring the knowledge base (Table 1).

The structural control department plans to establish a technique for controlling the structure of functionally gradient materials with complex shapes in the form of panels or curved surfaces, measuring about 300 cm. Their goal is to expand the practical use of the miniature specimen synthesis technology achieved so far. In this connection, there also are plans to develop a junction technique for cooled structures, which will be indispensable for its practical use (Table 2).

Table 1. Research for Themes for Material Design Department

Research topic	Research theme	Organization in charge of research
1 Method for estimating elasticity and plasticity analytic data based on microstructure models	Formulation of method for theoretically finding yield conditions and flow law of ceramics-metal mixed systems and material constant contained in them using microdynamic theory based on a microstructure model, and readjustment of input data retrieval environment for elastic and plastic thermal stream analysis	Tokyo Institute of Technology Shizuoka University
2 Method for measuring thermal property values, and data analysis	Research on optimum measuring technique for measuring thermal property values of ceramics-metal mixed systems, and a data analysis method Establishment of an effective technique for evaluating heat transfer characteristics through steady/nonsteady heat transfer analysis of multilayer substances focusing on their mixing ratios and gradient distribution	Mechanical Engineering Laboratory
3 Method for measuring high-temperature strength, and data analysis	Research on an optimum measuring technique for measuring high-temperature strength of ceramics-metal mixed systems, and a data analysis method Collection of high-temperature strength data of various mixed systems including fracture dynamical characteristic values	National Aerospace Laboratory
4 Thermal stress model with gradient structure, and an analysis method	Clarification of dynamic fracture characteristics of two-dimensional gradient structure with respect to assumed board and shell structural members Study of nonsteady heat transfer analysis and elastic, plastic thermal stress analysis of three-dimensional gradient structure with respect to members with complex shapes	Power Reactor and Nuclear Fuel Development Corp.

[continued]

[Continuation of Table 1]

Research topic	Research theme	Organization in charge of research
5 Optimum design support system	Development of design routine for functionally gradient materials based on analysis of nonsteady heat transfer, elasticity, and plasticity, and completion of an optimum design system with gradient structure through knowledge engineering support for structuring a knowledge base related to the correlation of process parameters, microstructure, properties	Daikin Industries
6 Structural design techniques for actual environments	Study of technical problems involving thermal, structural, and dynamic analysis of structural members exposed to high temperature air currents in the assumed actual environment of scram jet engines	Nissan Motor Co.
7 Research on design boundary conditions	Survey of aerodynamic heating conditions and chemical reaction conditions for the nose, wing front edge, and combustor of a hypersonic airframe, and structuring a database for design boundary conditions	Unexplored Science and Technology Association
8 Structuring of database and knowledge base	Improvement of various data collection and control systems, and expansion of information exchange function in the network connecting the three departments Structuring a knowledge base to promote correlation among process parameters, microstructure, and properties	National Aerospace Laboratory

The characteristic evaluation department will efficiently evolve the evaluation method it has readjusted, establish a nondestructive inspection technique for functionally gradient materials, implement various screening tests including a temperature-difference field thermal fatigue test and a high-temperature oxidation erosion-corrosion test, thus narrowing down the number of material systems that can be used in actual environmental tests (Table 3). In addition, it will carry out an actual environmental test to achieve a comprehensive evaluation of the structural characteristics of various materials. This test, in particular, will be implemented in a high-temperature, high-speed air current that will be close to the actual environment that hypersonic flying objects may encounter. This will make it possible to carry out a comprehensive evaluation of the characteristics of functionally gradient materials. Figure 14 presents an outline of the system.

Table 2. Research Themes for Structural Control Department

Medium item	Small item	Research theme	Organization in charge
1 Research on structural control technique based on physico-CVD	(1) Chemical vapor deposition (2) Physico-chemical fusion vapor deposition	Establishment of FGM synthetic technique using SiC/C systems produced by CVD Establishment of continuous control technique for SiC/C metals by combining physico-CVD	Tohoku University Nippon Oil Co. Sumitomo Electric Industries
2 Research on laminate molding technique by particle arrangement	(1) Particle injection method (2) Membrane laminate method	Research on consolidated, fine sintering behavior by injecting and filling ceramics and heat resistant metallic powders, and on microstructure control Development of technique for wide area arrangement, and molding and sintering techniques for producing FGM consisting of a ceramic material and an Ni-group alloy	Tohoku University Ishikawajima-Harima Heavy Industries Co. NKK Corp.
3 Research on laminate molding technique by thermal spray	(1) Different particles independent thermal spray [TS] technique (2) Different particles simultaneous TS technique	Study of synthetic conditions for FGM consisting of a metal and ceramics using two spray torches Completion of a technique for monobloc molding from ceramics to metal by integrating the above technique into a single torch	National Research Institute of Metals Nippon Steel Corp.
4 Research on structural control technique by self-exothermic reaction	(1) Reaction control technique (2) Wide arm control technique	Establishment of control technique for reaction, texture, and microtexture by combining textures of borides and metals by self-exothermic reaction Establishment of so-called wide area synthetic technique for obtaining large compacts without using high pressure, and heat manufacturing boric and metallic FGMs based on this technique	Government Industrial Research Institute, Tohoku

Table 3. Research Themes for Characteristics Evaluation Department

Research item	Research theme	Organization in charge
1 Techniques for evaluating erosion/corrosion characteristics	Development of techniques for evaluating erosion and corrosion characteristics, and fracture characteristics under oxidation atmosphere	Tohoku University
2 Technique for evaluating thermal stability of FGMs	Research on texture stability and changes over time of metallic single phase and metal-ceramics composite layers at high temperature	National Research Institute of Metals
3 Quantitative, nondestructive inspection techniques	Development of techniques for nondestructive inspection, microfracture process inspection, and quantitative evaluation applicable to materials with continuous texture change, such as FGM	Tohoku University Ship Research Institute Hitachi Construction Co.
4 Technique for evaluating thermal fatigue in temperature-difference field	Evaluation of thermal fatigue fracture characteristics of 30-mm diameter specimens and structural soundness related to thermal fatigue of FGM by means of laser heating thermal fatigue tests and a high temperature difference field test system	Mitsubishi Heavy Industries, Co. National Aerospace Laboratory
5 Characteristic evaluation technique using heavy thermal shock tests	Clarification of crack-generating behavior of materials by using a thermal load beam heating test system, irradiating with an electron beam and a hydrogen ion beam, and providing large functionally gradient materials with a thermal shock	Japan Atomic Energy Research Institute
6 Technique for evaluating long-time miniature dummy actual environment	Evaluation of durability using miniature specimens in a long-time test in a dummy aerodynamic heating field and a high-speed rotation field	National Aerospace Laboratory
7 Technique for evaluating a large actual environment	Comprehensive evaluation using large specimens to assess their thermal insulation quality and structural soundness through tests in environments encountered by hypersonic airframes such as space planes	National Aerospace Laboratory

9. Future Perspectives for Progress in Functionally Gradient Materials

Research and development of functionally gradient materials based on new concepts is being promoted as a way to create heat-resistant materials for use mainly in the aerospace field. Meanwhile, active discussions on how to apply them to other fields are under way. Table 4 shows possible applications of functionally gradient materials.

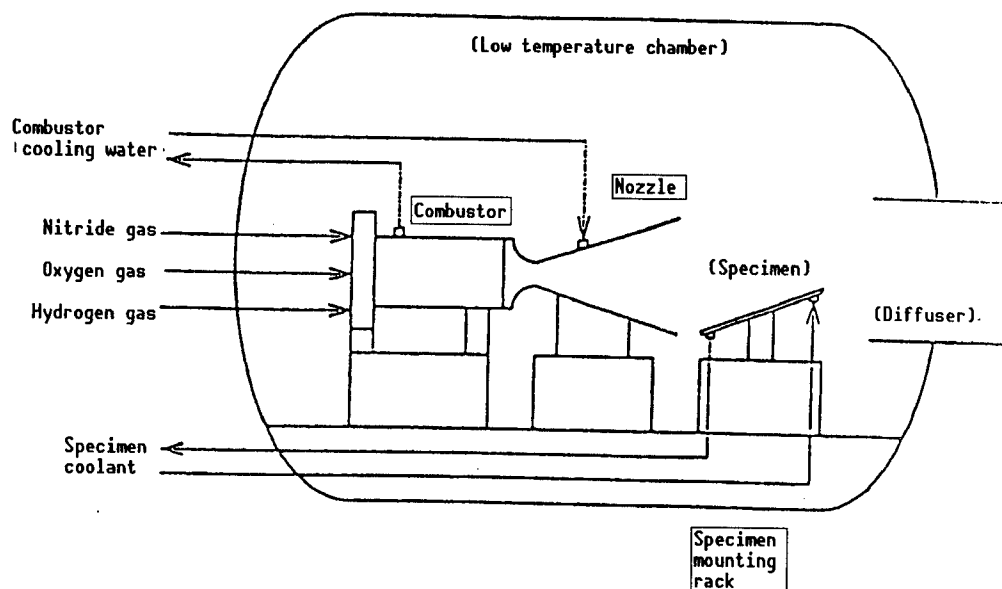

Figure 14. Actual Environment Evaluation Equipment for Functionally Gradient Materials (High-temperature gas flow evaluation test system)

At present, consideration is given to finding new fields of application and of adding concrete measures for that purpose in the functionally gradient material projects, etc. New fields of application being considered include, in addition to the aerospace field, a wide range from atomic energy to living related machines to biomedical fields. Extremely important for expanding the uses of functionally gradient materials are proposals to determine the needs of users and to explore the unique ideas of researchers across a wide range of fields. It is believed that only constant efforts by these people can lead to further progress in functionally gradient materials. The results of a study on the potential uses of functionally gradient materials will be published by the Functionally Gradient Materials Research Association, 3rd Floor, Toranomom Kotohira Kaikan Building, 1-2-8, Toranomom, Minato-ku, Tokyo = 105 Phone No. 03-3503-4681). This report is intended for wide general use.

Table 4. Repercussion of Gradient Functions Other Than Thermal Stress Relaxation

Function expected to be manifested	Field of application	Material combination and expected effect
Core function	Materials for first wall and its periphery (limiter, diverter) Electric insulating materials (for torus structure and superconductive materials use) Window materials for use in plasma instrumentation and control	Radiation resistance, thermal stress resistance, low Z quality Electric insulating quality Translucency, radiation resistance
Joining function	Ceramics engine Wear-resistant mechanical parts Heat-resistant mechanical parts Corrosion-resistant mechanical parts Other mechanical parts	Ceramics and metals Glass and metals Plastic and metal Dissimilar metals Dissimilar ceramics Dissimilar plastics Materials hitherto unjoinable can be firmly joined
Medical and biological functions	Artificial tooth Artificial tooth Artificial joint Artificial organ	Control of ceramics pore distribution Ceramics and plastic Ceramics and metal Control of gradient composition of biomedical organic materials Improved bioadaptability and reliability function can be expected compared to conventional materials

[continued]

[Continuation of Table 4]

Function expected to be manifested	Field of application	Material combination and expected effect
Electric, magnetic functions	Ceramics filter Ceramics oscillator Supersonic vibrator Magnetic disk Permanent magnet, electro-magnet three-dimensional composite electronics parts Silicon/compound semiconductor mixed IC Long-life heater	Gradient composition of piezoelectric substances Gradient composition of magnetic substances Gradient composition of metals Silicon and compound semiconductor Improved characteristics, lightweight, and miniaturization become possible
Sensor	Mount integrated sensor Acoustic sensor, sonar and supersonic diagnostic system well matching media Sensor with sensitivity distributed space-wise	Gradient composition between Sensor and mount materials Gradient composition of piezoelectric substances Improved measuring precision Measuring under hazardous environments
Optical function	High performance laser rod Large aperture GRIN lens Optical disk	Gradient composition of optical materials
		High-performance optical parts
Chemical function	Functional polymeric film catalyst	Metals, ceramics, plastic, glass, proteins, cement
(Consumer field)	Paper, fiber, clothing, food, building materials	

References

1. Buchmann, O.A., "Thermal Structural Design Study of an Airframe Integrated Scramjet," NASA-CR, 1979, p 3141.
2. Investigation Report on FY85 Expenses for Promotion of Science and Technology, Research and Development Bureau, Science and Technology Agency, Mar 87.

3. Hirano, T., et al., "Japan Material Dynamics Meeting Papers," 1985.
4. Hirano, T., et al., Abstracts of papers, 16th International Symposium on Space Technology and Science, May 88.
5. Igarashi, R., et al., Report on the Results of "Research on Key Technologies for Developing Functionally Gradient Materials for Relaxing Thermal Stress (1st period)," Mar 91.
6. Tamura, M., Ibid.
7. Saitoh, T., et al., Ibid.
8. Sanada, T., et al., Ibid.
9. Kumagawa, A., et al., Ibid.
10. Nino, M., et al., "Functionally Gradient Materials," JAP. SOC. ELECTRI. JOUR., Vol 110 No 1, Jan 90.
11. Takahashi, H., et al., Report on the Results of "Research on New Technologies for Developing Functionally Gradient Materials for Relaxing Thermal Stress (1st period)," Mar 91.

- END -

NTIS
ATTN PROCESS 103

2

5285 PORT ROYAL RD
SPRINGFIELD VA

22161

This is a U.S. Government publication. Its contents in no way represent the policies, views, or attitudes of the U.S. Government. Users of this publication may cite FBIS or JPRS provided they do so in a manner clearly identifying them as the secondary source.

Foreign Broadcast Information Service (FBIS) and Joint Publications Research Service (JPRS) publications contain political, military, economic, environmental, and sociological news, commentary, and other information, as well as scientific and technical data and reports. All information has been obtained from foreign radio and television broadcasts, news agency transmissions, newspapers, books, and periodicals. Items generally are processed from the first or best available sources. It should not be inferred that they have been disseminated only in the medium, in the language, or to the area indicated. Items from foreign language sources are translated; those from English-language sources are transcribed. Except for excluding certain diacritics, FBIS renders personal names and place-names in accordance with the romanization systems approved for U.S. Government publications by the U.S. Board of Geographic Names.

Headlines, editorial reports, and material enclosed in brackets [] are supplied by FBIS/JPRS. Processing indicators such as [Text] or [Excerpts] in the first line of each item indicate how the information was processed from the original. Unfamiliar names rendered phonetically are enclosed in parentheses. Words or names preceded by a question mark and enclosed in parentheses were not clear from the original source but have been supplied as appropriate to the context. Other unattributed parenthetical notes within the body of an item originate with the source. Times within items are as given by the source. Passages in boldface or italics are as published.

SUBSCRIPTION/PROCUREMENT INFORMATION

The FBIS DAILY REPORT contains current news and information and is published Monday through Friday in eight volumes: China, East Europe, Central Eurasia, East Asia, Near East & South Asia, Sub-Saharan Africa, Latin America, and West Europe. Supplements to the DAILY REPORTs may also be available periodically and will be distributed to regular DAILY REPORT subscribers. JPRS publications, which include approximately 50 regional, worldwide, and topical reports, generally contain less time-sensitive information and are published periodically.

Current DAILY REPORTs and JPRS publications are listed in *Government Reports Announcements* issued semimonthly by the National Technical Information Service (NTIS), 5285 Port Royal Road, Springfield, Virginia 22161 and the *Monthly Catalog of U.S. Government Publications* issued by the Superintendent of Documents, U.S. Government Printing Office, Washington, D.C. 20402.

The public may subscribe to either hardcover or microfiche versions of the DAILY REPORTs and JPRS publications through NTIS at the above address or by calling (703) 487-4630. Subscription rates will be

provided by NTIS upon request. Subscriptions are available outside the United States from NTIS or appointed foreign dealers. New subscribers should expect a 30-day delay in receipt of the first issue.

U.S. Government offices may obtain subscriptions to the DAILY REPORTs or JPRS publications (hardcover or microfiche) at no charge through their sponsoring organizations. For additional information or assistance, call FBIS, (202) 338-6735, or write to P.O. Box 2604, Washington, D.C. 20013. Department of Defense consumers are required to submit requests through appropriate command validation channels to DIA, RTS-2C, Washington, D.C. 20301. (Telephone: (202) 373-3771, Autovon: 243-3771.)

Back issues or single copies of the DAILY REPORTs and JPRS publications are not available. Both the DAILY REPORTs and the JPRS publications are on file for public reference at the Library of Congress and at many Federal Depository Libraries. Reference copies may also be seen at many public and university libraries throughout the United States.