

AFIT/GCS/ENG/97D-06

USER LOCATION DETERMINATION STRATEGY
IN A LOW EARTH ORBIT SATELLITE NETWORK

THESIS
Jaehee Lee
Major, ROK Army

AFIT/GCS/ENG/97D-06

19980121 067

DTIC QUALITY INSPECTED 3

Approved for public release; distribution unlimited

The views expressed in this thesis are those of the author and do not reflect the official policy or position of the Department of Defense or the U. S. Government.

AFIT/GCS/ENG/97D-06

USER LOCATION DETERMINATION STRATEGY
IN A LOW EARTH ORBIT SATELLITE NETWORK

THESIS

Presented to the faculty of the Graduate School of Engineering
of the Air Force Institute of Technology
Air University
In Partial Fulfillment of the
Requirements for the Degree of
Master of Science in Electrical Engineering

Jahee Lee, B.S.

Major, ROK Army

December, 1997

Approved for public release; distribution unlimited

USER LOCATION DETERMINATION STRATEGY
IN A LOW EARTH ORBIT SATELLITE NETWORK

THESIS

Jaehee Lee, B.S.

Major, ROK Army

Presented to the Faculty of the Graduate School of Engineering
of the Air Force Institute of Technology
In Partial Fulfillment of the
Requirements for the Degree of
Master of Science in Electrical Engineering



Member Lt Col David M. Gallagher



Member Major Michael L. Talbert



Chairman Major Richard A. Raines

Acknowledgments

I would like to thank a number of people who have helped with this effort. First of all, Major Richard A. Raines, my thesis advisor, showed me a right way and enormous advice with patient. Lt. Col. David M. Gallagher and Major Michael L. Talbert, my thesis committee, also provided me a special guidance. Major Keith A. Shomper, my academic advisor, helped me on adapting and scheduling my AFIT life. Also, Mrs. Annette R. Robb, mother of all international student, and her staffs have helped me adapting to new environment, custom, and culture.

Of course, this whole experience at AFIT would not have been possible without the loving support from my wife, Hyungmi, my daughter, Youjeong, and my son, Gihong.

Finally, I want to thank my Lord and Savior for His love, patient, and mercy.

Jahee Lee

Table of Contents

Acknowledgments	i
Table of Contents.....	ii
List of Figures	v
List of Tables	vii
Abstract	viii
1. INTRODUCTION	1
1.1 Background.....	1
1.2 Problem.....	1
1.3 Scope	2
1.4 Approach	2
1.5 Summary.....	2
2. PRIOR WORK	4
2.1 Introduction	4
2.2 Planned LEO satellite network systems.....	5
2.3 Problems associated with LEO satellite systems.....	7
2.4 User Location Management Algorithms in Wireless PCS Networks	8
2.5 Summary.....	12
3. ALGORITHM DERIVATION	13

3.1 Introduction	13
3.2 User Location Management Standard of Cellular Network (IS-41)	13
3.3 Choice of User Location Update Method	15
3.4 Basic Requirements Needed for Dynamic User Location Determination	15
3.5 User Location Determination Algorithm for Satellite Network System.....	21
3.6 Simulation Construction	23
3.7 Data Collection.....	25
3.8 Operational Assumptions.....	27
3.9 Verification / Validation.....	29
3.10 Summary.....	29
4. RESULT AND ANALYSIS	31
4.1 Simulation Execution	31
4.2 Call Setup Performance Analysis	32
4.3 Memory Requirement for the Satellite Approach	36
4.4 Processing Delay Associated with Data Access	39
4.5 Message Traffic Distribution Over the Satellite	39
4.6 Summary.....	41
5. CONCLUSIONS	43
5.1 Overall Performance Comparison.....	43
5.2 Future Research	44
5.3 Conclusion.....	45
APPENDIX A.....	46

A.1 Satellite Approach	46
A.2 Gateway Approach	59
A.3 Data Structure of Call Setup Request Packet.....	63
Bibliography	65
Vita.....	66

List of Figures

<i>Number</i>	<i>Page</i>
Figure 1 Constellation of Iridium system.....	6
Figure 2 Constellation of Globalstar system.....	6
Figure 3 Constellation of Teledesic system.....	7
Figure 4 Top level block diagram of the Satellite Approach.....	24
Figure 5 Top level block diagram of the Gateway Approach.....	26
Figure 6 Call Setup Delay vs. Area Size.....	32
Figure 7 Call Setup Delay vs. Number of Gateway.....	34
Figure 8 Hop Count vs. Area Size.....	35
Figure 9 Hop Count vs. Number of Gateway.....	36
Figure 10 Message Distribution over Orbits-Satellite Approach.....	40
Figure 11 Message Distribution over Orbits-Gateway Approach.....	40
Figure 12 Relationship between Orbits and Gateways.....	41
Figure 13 User Location Determination-Satellite Approach.....	46
Figure 14 Initialize System.....	49
Figure 15 Update Satellite.....	50
Figure 16 Update Mobile User.....	50
Figure 17 Update AUT.....	51
Figure 18 Update VUT.....	51
Figure 19 Traffic Generator.....	52
Figure 20 Destination User Generator.....	52
Figure 21 Find Start-SAT and End-SAT.....	53
Figure 22 Search Nearest SAT.....	53
Figure 23 Delay Start SAT \leftrightarrow Source Link.....	54
Figure 24 Route from SAT to SAT.....	55
Figure 25 Delay SAT \leftrightarrow SAT Link.....	55
Figure 26 Find Destination User Location.....	56

Figure 27 Page from End-SAT	56
Figure 28 Search Destination	57
Figure 29 Change End-SAT to Next Priority SAT	58
Figure 30 Delay End-SAT ↔Destination Link.....	58
Figure 31 Reroute from SAT to SAT	59
Figure 32 Connection Established	59
Figure 33 User Location Determination-Gateway Approach.....	60
Figure 34 Initialize System[GW].....	61
Figure 35 Find Start-SAT and End-SAT[GW]	62
Figure 36 Find Destination User Location[GW].....	62
Figure 37 Delay SAT→GW Link.....	63

List of Tables

<i>Number</i>	<i>Page</i>
Table 1 Area to Satellite Table for 1 time slot.....	18
Table 2 Absent User Table (AUT) of Area-A's home gateway (or LHS).....	20
Table 3 Visiting User Table (VUT) of Area-D's home gateway (or LHS).....	20
Table 4 Probability of satellite selection as the number of area varies	33
Table 5 SatCom-Traffic Data Structur	64

Abstract

Recently, many Low Earth Orbit (LEO) satellite systems have been proposed for the purpose of global communication and one of those systems is planned to start the commercial service in 1998. These LEO satellite systems are providing most of current communication services (voice, fax, data, paging, and even real time video service) without any limitation on place and time. However, little is published about their detail system methodology on user tracking and managing schemes. This thesis presents two user location tracking algorithms in a LEO environment. One (*Gateway Approach*) is the most likely approach under present system proposals, while the other (*Satellite Approach*) requires more risk in implementing the proposed scheme. These two approaches are compared via computer simulation in an Iridium-like satellite network system environment. Comparative measures of call setup delay and number of hops needed to establish initial call request are examined, and minimum requirements for the *Satellite Approach* are discussed. It is concluded that the *Satellite Approach* performs better than the *Gateway Approach* when the memory space and computational ability of each satellite can satisfy the minimum conditions discussed in this paper. Also, the *Satellite Approach* experienced well balanced message distribution than the *Gateway Approach*. Moreover, as far as system survivability and service continuity, the *Satellite Approach* showed more advantageous factors than the *Gateway Approach*.

1. INTRODUCTION

1.1 Background

For decades, geostationary satellite systems have been in the main stream of the satellite communications industry, because of reliable communications with ease of ground station tracking due to their "fixture in space" characteristics. However, major drawbacks to geostationary systems are their size, energy requirements, and the one-way signal propagation times of approximately 120 milliseconds.

In order to reduce the size, energy requirements, and propagation delay associated with geostationary systems, researchers have begun to reexamine the possibilities of placing multiple cooperating satellites into low earth orbital (LEO) planes. Against having the advantages of reductions in size, energy requirements, and signal propagation times, LEO satellite systems have disadvantage of the increased number of satellites required to cover whole globe.

1.2 Problem

Like cellular network system environment, LEO satellite network systems need to maintain user location information in order to provide prompt connection between mobile users. This leads the need of effective user location update mechanism and delay-free retrieving algorithms for LEO satellite network systems. However, little is known about the

algorithms related with this problem and no official technical document is published yet, even though one of the major LEO satellite network systems is planned to start commercial services in 1998.

This thesis examines user location update (ULU) and user location determination (ULD) algorithms in the cellular network system. From this examination, two user ULU and ULD algorithms for LEO satellite network system environment are modeled and analyzed.

1.3 Scope

This research suggests two ULU and ULD algorithms and compares the performance of those two algorithms in terms of call setup delay, message distribution, and memory requirement. No devices are implemented in this thesis.

1.4 Approach

First, using current standard of ULU and ULD algorithms in cellular network system, two new ULU and ULD algorithms for LEO satellite network were derived. Then, using BoNES Designer and SatLab simulation tools published by Cadence Software, two ULU and ULD algorithms were simulated. Because of the fact that only the Iridium satellite network system has the inter-satellite link (ISL) function, this system is used for examination via simulation.

1.5 Summary

This thesis is organized as follows. Chapter 2 gives a brief survey of previously proposed user location tracking schemes in cellular network systems. In Chapter 3, two user

location tracking algorithms are proposed for satellite network systems. Chapter 4 presents the performance analysis of the two different algorithm and the conclusion is given in Chapter 5.

2. PRIOR WORK

2.1 Introduction

Since the first satellite launch, there has been an increase in use and diversity of application (i.e. mobile communication, TV broadcasting, weather reporting, Global Positioning Service, military reconnaissance) for these machines. Now, more than two thousands satellites currently operate in space and more than seventeen hundreds satellites will be launched within ten years [Wha97]. Most early satellites were fixed in a geostationary orbit (GEO satellites) and provided continuous communication service to a small number of users at high data rates in a given area. The high altitude (about 35,785 km) of the geostationary orbit, however, results in a one-way single-hop (uplink and downlink) propagation time of at least 0.25 seconds.

The only way to overcome the 0.25 seconds propagation delay associated with GEO satellites was to put satellites in orbits of lower altitude. In doing so, the delay can be reduced to approximately 0.005 seconds for an up/downlink transmission for a satellite at an altitude of 780 km. A trade-off exists in using low-earth orbit satellite systems (LEO satellites) compared to GEO satellites. LEO satellites must maintain high orbital velocities (approximately 17,000 mph) in order to keep their altitude. And also the region which can be covered by one LEO satellite is relatively small. Thus, in order to cover on a larger area without any loss of coverage, more satellites are needed.

2.2 Planned LEO satellite network systems

There are three types of LEOs: little-LEOs, big-LEOs, and broadband-LEOs [Cor97]. Little-LEOs operate at frequencies below 1 GHz. Orbital Sciences Corporation's OrbComm, STARSYS Incorporation's STARNET, Volunteers in Technical Assistance's VITASET are examples [WuM94] of little LEOs. They are designed to provide full-time, global, two-way digital communications services: messaging, emergency alerts, position determination, and remote data collection. "Little" means that the satellites are small and light compare to big-LEOs and also scheduled to provide only low bit rates (of the order of 1 kb/s).

Big-LEOs operate at frequencies between 1 and 3 GHz. They will provide a full range of mobile satellite services: voice, data, fax, paging and RDSS. Motorola's Iridium, Loral and Qualcomm's Globalstar, and TRW's Odyssey are members of the big-LEO family. The Iridium system comprises 66 satellites in 6 near polar orbits at an altitude of 785 km. Iridium will provide full services with global coverage [WuM94]. It is also the only big-LEO system attempting to use satellite-to-satellite crosslinks designed to make the network system be more flexible in propagating messages. Figure 1 shows the constellation of Iridium satellite system.

Globalstar, which is being developed by Loral Aerospace Corporation and Qualcomm, consists of 48 LEO satellites orbiting at an altitude of 1,401 km. The satellites are equally divided into eight orbital planes. The system will use traditional bent-pipe transponders instead of on-board processing (used in Iridium system) and is intended to work with the

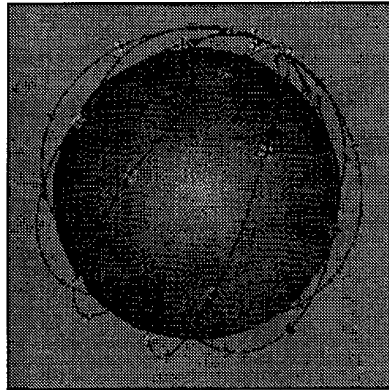

Figure 1 Constellation of Iridium system.

existing public switched telephone network (PSTN). Calls are relayed through the satellite only when access cannot be made via the terrestrial network. The existing PSTN will be accessed via gateways and will be used for long-distance connections including transoceanic calls [WuM94]. Figure 2 shows the constellation of Globalstar satellite system.

The Teledesic satellite system is by far the newest and the most ambitious of the proposed systems. It consists of 840 satellites. The satellites reside in 21 planes in a sun-

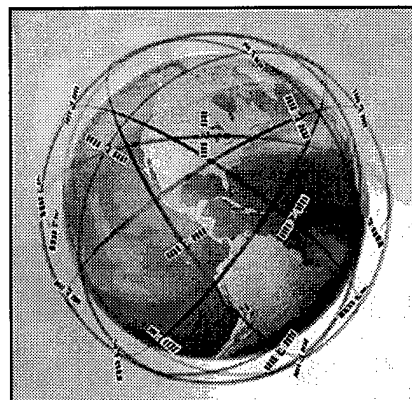

Figure 2 Constellation of Globalstar system.

synchronous, inclined circular low earth orbit. Teledesic aims at providing high data rate (broadband) fixed and mobile services, continuous global coverage, fiber-like delay and bit error rates less than 10^{-10} . Thus, rather than targeting voice and supporting low bit rate data as the big-LEOs do, Teledesic focuses on providing wireless broadband services with a fiber-like quality, focusing on data and supporting voice. Figure 3 shows the constellation of Teledesic satellite system.

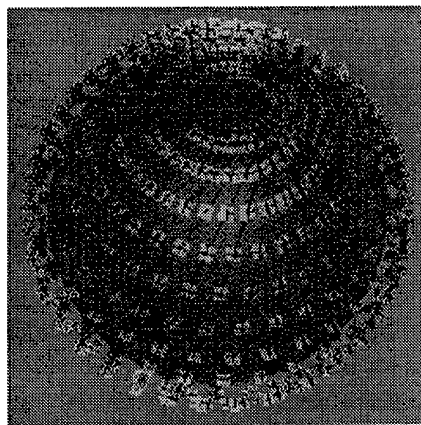

Figure 3 Constellation of Teledesic system

2.3 Problems associated with LEO satellite systems

As mentioned earlier, satellites in LEO are moving at speeds of 15,000 to 17,000 km per hour. This means that the inter-satellite network topology is rapidly changing. Also, the satellite itself is not as powerful as the terrestrial network nodes because of the limited space and energy capability. Under these circumstances, a database is needed by a user location update (ULU) policy that minimizes the computational overhead and cost. An user location determination (ULD) algorithm is also needed to use that database. In this thesis, two types of user location determination algorithms are proposed along with a user location update

algorithm for the LEO satellite network environment. The performance of the two algorithms are then compared.

2.4 User Location Management Algorithms in Wireless PCS Networks

In most wireless personal communication services (PCSs), the most recent location of the user is needed to efficiently communicate. For mobile networks, user location determination may be inexact. The source determines the most likely location of the destination user. Then the source terminal tries to find the destination from this location. If the destination terminal is still in that location, end-to-end communication can begin. But if the user is not there, the source terminal has to propagate the searching signal to adjacent locations until it finds the destination. Predicting expected user location usually depends on the history of calls and moving pattern of the terminals [AkH95]. Terrestrial cellular systems use these pieces of information for assistance in finding mobile users.

The authors of [BaK93] introduced a mobile terminal location update scheme under a cellular architecture where base stations are interconnected by wireline links. In this scheme, reporting cells are defined as a subset of the cells. A mobile terminal reports its location only when entering one of these reporting cells. When an incoming call arrives, the source terminal starts searching from the cell where the destination terminal last reported its location. Finding an optimal set of reporting cells has been shown to be a NP-complete problem. Moreover, this scheme doesn't consider the call arrival and movement patterns of individual mobile terminal. For example, a mobile terminal located near the boundary of

two reporting cells may have to report the location update whenever it crosses the boundary, even if the arrival probability of incoming call is low.

The same authors of [BaK93] also proposed another three tracking strategies for mobile users in wireless network: Distance-Based Update, Movement-Based Update, and Time-Based Update [BaK94]. In the Distance-Based Update model, the user location updates are performed based on the distance (denoted by D) between its current cell and the cell in which it last reported. In a same manner, location update of Movement-Based model is performed whenever it completes M movements between cells. In Time-Based model location update is just performed every T time slots.

In terms of implementation overhead, the time-based strategy is the simplest since mobile terminals only have to send update message according to their local clocks. The movement-based strategy is more difficult to implement since mobile terminals have to count the number of movement whenever they cross boundaries between cells. The distance-based strategy is most difficult to implement because all mobile terminals have to know about the topology of cells in order to calculate the distance.

In each method, the expected number of update messages per slot transmitted by a user and the expected number of searches necessary to locate a user were calculated. The numerical results of this paper showed that the distance-based strategy requires 2.5 times less update rate than two other strategies do for achieving a cost of search equals to 3, even though it required the highest overhead in its implementation.

Akyildiz and Ho suggested a novel dynamic user location update mechanism [AkH95]. According to this paper, a mobile terminal dynamically determines when to update after moving to a new cell based on its mobility pattern and the incoming call arrival probability. The key idea behind this mechanism is that it updates user location just before its update¹ cost becomes greater than paging² cost. In other words, if the paging cost is less than the location update cost, location update is no longer needed. By using expected paging cost and location update cost according to the movement pattern of terminal user, the mechanism can calculate the expected next update time. The algorithm also calculates the call arrival probability that is used to find the next update time, by collecting the previous call arrival information at the registers of mobile terminals.

Since all the papers mentioned before talk about ULU strategies under the cellular network systems, it is very difficult to say that which strategy is adequate for satellite network system without any experiment. Compare to cellular network system, the boundary of satellite network system is much larger and unit area size needed location update is not known yet. Also, the mobility pattern of mobile terminals of the satellite network will not be same as that of cellular network since the purpose of satellite network system is global communication and that of cellular network system is local communication.

One paper published in March 1997 compares satellites network systems and cellular network systems in terms of location update and call setup procedure [Hub97]. This paper

¹ Updating cost represents each cost for updating user location and this is independent of the location of the mobile terminal.

² Paging cost represents the cost for polling each cell during the terminal paging process.

concludes that the methods used for location update, call setup, call handoff, and cell reuse are surprisingly similar, even though the two systems' architectures, services provided, and subscriber number formats vary enormously.

According to [Hub97], all user location information is managed by each gateway. All mobile users are registered to their Home Gateway. Whenever mobile users enter into a new gateway area, they send update signals to Visited Gateway. Visited Gateway adds visiting mobile user information to its visited location register (VLR) database and sends current location information of visiting mobile user to his/her Home Gateway. Then, the Home Gateway of visiting mobile user updates its home location register (HLR).

In order to connect to the Iridium mobile user roaming in a Visited Gateway, the call signal is first routed to the Home Gateway of mobile user via the PSTN. From the HLR in the Home gateway, a call signal retrieves the Visited Gateway information of mobile user and reroutes the call signal to the Visited Gateway via the Iridium satellite crosslink system. The Visited Gateway looks in the VLR to identify the mobile user's location and reroute the call signal to the satellite directly over the destination mobile user.

The user location update strategy used in this paper is similar to Movement-Based update strategy [Bak94], where the movement is defined as crossing over the gateway boundary. But, the optimized size of one gateway boundary or required number of gateways, which can be a very important factor in terms of system performance, is not discussed in this paper.

2.5 Summary

Limited work has been found in the open literature related to ULU/ULD strategies proposed for PCS network. Among them, only [Hub97] provided a big picture of LEO-based ULU/LUD concept. In order to adapt the ULU/ULD strategies discussed above to a satellite network environment, the satellite is considered to be a reporting cell in the cellular system. Even though satellites are moving at a high velocity (1200 m/s), at least one satellite can cover a certain area without disconnection. If we assume that the satellite gracefully hands all the communication link information over the next satellite, we can also regard those many traveling satellites as one fixed satellite working continuously over one specific area. This assumption leads the satellite communication system to be the same as a cellular network system. Based on this assumption, new ULU/ULD algorithms are developed for LEO satellite network systems. In next Chapter, the standard of a user location tracking scheme in cellular network systems (IS-41) is reviewed and then two user location tracking algorithms are derived based on IS-41 standard.

3. ALGORITHM DERIVATION

3.1 Introduction

Before mentioning ULU/ULD algorithms for LEO satellite, the current cellular network standards are examined in order to get a basic understanding of the cellular network systems. Because both cellular and satellite network system are working under the mobile communication environment [Log95], common aspects exist in terms of overall system architectures. After discussing these commonalities, a new ULU/ULD algorithms for LEO satellite network is introduced. A discussion of the simulation models developed to analyze and compare the performance of these algorithms follows.

3.2 User Location Management Standard of Cellular Network (IS-41)

3.2.1 Database Managed by IS-41

IS-41 protocol is a public communications network (PCN) location management standard for North America area and this algorithm is performing based on two-level database hierarchy [EIA91]. Two types of database, home location register (HLR) and visitor location register (VLR), are used to store the location information of the mobile terminals. According to the IS-41 location strategy, the cellular network system maintains all the user information as follows.

- Each cell has its own base station (BS) and one registration area (RA) is consist of several cells. All cells are wired to a mobile switching center (MSC).
- Each registration area (RA) has a mobile user information under its area. This database is called visitor location register (VLR) and co-exist with MSC

- All the information in the VLR, in turn, will be transmitted to the home location register (HLR).

3.2.2 User Location Update (ULU) Procedure

Using these databases (HLR, VLR), mobile users update their latest location information whenever they enter into the new register area. The operation of the ULU procedure is as follows. :

- Each Mobile User updates their location to the nearest BS whenever they move into new RA. (Updating time varies according to updating algorithm.)
- The BS forwards this message to the new serving MSC.
- The new MSC updates its associated VLR, indicating that the mobile terminal is now residing in its service area and sends a location registration message to the HLR.
- The HLR sends a registration acknowledgment message to the new MSC/VLR together with a copy of the subscriber's user profile.
- The HLR sends a registration cancellation message to the old MSC/VLR.
- The old MSC removes the record for the mobile terminal at its associated VLR and send a cancellation acknowledgment to the HLR.

3.2.3 User Location Determination (ULD) Procedure

From the previous procedure, it can be seen that HLR always know the location of all mobile users. So, the mobile user (or non-mobile user) can easily find the destination mobile user by searching the HLR database. The detailed ULD procedure is as follows. :

- The calling mobile terminal sends a call initiation signal to its serving MSC through the nearby BS.

- The MSC of the calling mobile terminal sends a location request message to the HLR of the mobile terminal.
- The HLR determines the cell location of the called mobile terminal and sends a route request message to this MSC.
- The MSC determines the cell location of the called mobile terminal and assigns a temporary location directory number (TLDN) to the called mobile terminal. The MSC then sends this TLDN to the HLR
- The HLR sends the TLDN to the MSC of the calling mobile terminal. The calling MSC can now setup a connection to the called MSC through the PSTN.

3.3 Choice of User Location Update Method

In this thesis, no new ULU method for satellite network systems is introduced, the Movement-Based update method from [Bak94] is selected for examination since it is both cost-effective and feasible to implement. The movement threshold was set to 1, which represents that the mobile user updates its location whenever he/she crosses a new RA.

In real life, these RAs (coverage areas) may be distinguished by geopolitical relationship or may be divided by geographical position. In this thesis, a geographical division method is applied since geopolitical division requires more detailed political information about global areas and this makes the simulation implementation impossible at this point. The method of geographical division is explained at the end of this chapter in Section 3.8.

3.4 Basic Requirements Needed for Dynamic User Location Determination

As previously mentioned, in order to find the destination mobile user immediately (without using flooding search), some mechanism has to keep track of all mobile users and provide the mobile user information when it is needed by another user. Under the cellular network environment, all the mobile users update their current location as they move and

those information are maintained in each registration areas (RAs) in the form of VLR and HLR. VLR contains only regional user information, while HLR contains all the user profiles in its whole system. Likewise, for the mobile satellite network system, there is a need to put all the information of satellite network users in a place (or many places) where all the mobile users can dynamically retrieve the information. The most likely choice for this storage place is gateways or satellites.

3.4.1 The Places for Saving User Information

Gateways almost have no limit on memory space and computational ability related with satellite positioning and routing, database searching and updating. As many satellite network systems are aiming for global communication capability, it seems to be very hard to maintain all the mobile user information at one place. One simple answer for this problem is that all the mobile satellite user information can be managed distributively by several gateways that are located in different locations around the world. In other words, each gateway is only taking care of mobile users who are currently traveling within the boundary of each gateway. This can reduce not only the message traffics between the gateway and the adjacent satellite, but also call setup delay. Nevertheless, we can still expect some bottleneck near to gateways, because of frequent access to gateways.

Another possible place for holding the user information database is within each orbiting satellite. Each satellite in the system can work as gateway. These satellites have limited memory space and computational ability compare to gateways. But there exists a few advantages of this approach if we overcome the memory and computation limitations. One

advantage is that we can remove the bottleneck from the entire system. This is due to the fact that there is no need to access a gateway for the purpose of location update or call setup. Another advantage is that we can also expect the reduced call setup delay compare to the gateway approach. Because the call request can be directly routed to the destination satellite without connecting to the terrestrial gateways, the total setup delay can be reduced by at least two times of up/down link delay.

3.4.2 Area to Satellite Table (AST)

Satellite network topology used for this investigation is changing with a uniform pattern and repeats infinitely. This means that we can calculate the position of each satellite or find it using pre-calculated topology table for a given time slot [ChK95]. If the global area can be divided into many small areas called Iridium Registration Area³ (IRA), then a match can be made for an IRA to satellites that can completely or partly cover the given area during one time slot. The maximum size of one IRA must be smaller than one satellite's footprint size in order to cover one IRA with only one satellite. And also some IRA cannot be covered entirely by one satellite for a given time slot, if the IRA is located in the boundary area between two or more satellites' footprint. In that case, one IRA can be covered by more than two satellites. Using previous assumptions, we can build a 'Area⁴ to Satellite Table (AST)' for a given time slot. Each IRA is mapped to satellites that are completely or partly covering the IRA. This table can be obtained by calculating the distance between IRA and

³ An area which has its own Iridium Area Code

⁴ Area implies a Iridium Registration Area.

satellites which can be visible from the IRA, and set the closest satellite to the highest priority. Maximum number of satellites needed to cover one IRA can be varied according to its position or satellite topology. Thus, this value is not determined, yet. Table 1 shows an example of 'Area to Satellite Table (AST)' for one time period. This AST must be updated continuously as the satellites move. This implies that each satellite must have a computational ability to update the AST within a given update interval.

Table 1 Area to Satellite Table for 1 time slot

IRA-ID	SAT-ID (Priority1)	SAT-ID (Priority2)	SAT-ID (Priority3)
1	S ₁	S ₂	S ₃
2	S ₂	S ₃	S ₄
:	:	:	:
:	:	:	:
R	S ₆	S ₇	S ₈

If we are using a flooding type of algorithm, we only need AST tables that can be used for the starting point (satellite) of searching destination user.

3.4.3 Logical Home Satellite (LHS)

Whenever the new mobile user registers in the satellite network system, the new user will be given a unique User-ID that will be similar to the current telephone numbering system. This User-Id will then need to be saved to the nearest gateway station or nearest satellite passing over the user's home area (initial area). In a satellite network system all satellites are

moving with a high velocity relative to the user. Therefore, the satellite cannot function like base station (BS) in a cellular system. Each area can find at least one best satellite at any time slot from the AST table. This satellite is considered to be the logical home satellite (LHS). Moreover, one satellite can work as the LHS for multiple IRAs if the footprint of that satellite covers many IRAs. Thus, each satellite works as LHS of its footprint area, and the LHS of one specific IRA is continuously changing as the satellite moves. We assume that the information on mobile users of each IRA will be managed by its LHS and the information will be gracefully handed over to the next LHS as time changes.

3.4.4 Home Area (HA) / Home Gateway (HG)

Normally, one gateway can cover more areas than one LHS can if the number of gateways is less than that of satellites. When a new mobile user registers with a satellite network system, he will get an IRA-ID and User-ID. This IRA-ID will be the user's home area and the area will be subordinated to a nearest gateway, which will be the user's home gateway. Thus, each mobile user will have its own home area (HA), logical home satellite (LHS), and home gateway (HG) as soon as he enrolls to the system.

3.4.5 Databases Needed in Satellite Network System

Like a cellular system, two tables need to be maintained by HGs (or LHSs). The first one is absent user table (AUT). This table contains the list of mobile users who are traveling out of their home area (HA) and their last reported current IRA-ID. Table 2 shows an example of absent user table (AUT). For instance, if User-1 and User-2 of Area-A are

traveling out of their home area, the AUT of home gateway (HG) or logical home satellite (LHS) will be updated as soon as they report their current Area-ID.

Second, the information of visitors who came from the other area is known. This table is

Table 2 Absent User Table (AUT) of Area-A's home gateway (or LHS)

User-ID	Current IRA-ID
User-1	Area-D
User-2	Area-F
:	:

named the visiting user table (VUT) and contains the visiting user list and their home IRA-ID. Table 3 shows an example of visiting user table (VUT). From the previous example, User-1's data is added to visiting user table (VUT) in home gateway (or LHS) of Area-D right after he requested his location update. After updating the VUT, the home gateway (or LHS) of Area-D sends the visitor's current location information to visitor's home gateway

Table 3 Visiting User Table (VUT) of Area-D's home gateway (or LHS)

User-ID	Home IRA-ID
User-1	Area-A
User-3	Area-B
:	:
:	:

(or LHS) in order to update its AUT.

3.5 User Location Determination Algorithm for Satellite Network System

In this section, two ULD algorithms are proposed for satellite network systems. The first algorithm uses HGs for user information storage while the second uses LHSs. But, both algorithms have a same concept in a sense that all mobile users are updating their recent location to the nearest storage place (HG or LHS) and call request paging starts from destination user's last updated area.

3.5.1 Gateway Approach

In this algorithm, user information tables (AUT and VUT) are saved in the gateways which are located in many different places over the world. These gateways will also be used as the access point from terrestrial networks to satellite networks (or vice versa). Because of the unlimited memory space of gateways, one gateway can hold as much data as needed. However, as the number of mobile users that are managed by one gateway increases, message traffic to the gateway will also increase. Thus, there is a trade-off between the number of gateways and message congestion. This relationship is examined with the results discussed in Chapter 4.

3.5.1.1 Location Update Procedure

- ❖ Whenever a mobile user enters into the new IRA, the User-ID and Home IRA-ID are reported to the new IRA's home gateway (HG).
- ❖ The gateway updates visiting user table (VUT) of the new IRA.
- ❖ If the home gateway (HG) of the visitor is same as that of new IRA,

- ◆ Then, the gateway updates the absent user table (AUT) of the visitor's home area (HA).
- ◆ Else, the gateway sends the visitor's Current IRA-ID to his home gateway (HG) and update the absent user table (AUT) of visitor's home area (HA).

3.5.1.2 Call Setup Procedure

Let's assume that mobile user 1 (MU1) tries to communicate with mobile user 2 (MU2) via satellite network. The nearest satellite of MU1 will be the start satellite (S-SAT) of the connection path and that of MU2 will be the end satellite (E-SAT).

- ❖ MU1 sends a call setup request to S-SAT.
- ❖ S-SAT sends the call setup request to MU2's home gateway (HG).
- ❖ If MU2's home gateway (HG) finds his User-ID in the AUT,
 - ◆ Then, the nearest satellite from MU2's current IRA will be the E-SAT and the call setup request will be rerouted to the E-SAT.
 - ◆ Else, the nearest satellite from MU2's home IRA will be the E-SAT and the call setup request will be rerouted to the E-SAT.
- ❖ Page the call request from the E-SAT.
- ❖ If MU2 replies,
 - ◆ Then, call setup is established.
 - ◆ Else, reroute the call setup request to next priority E-SAT and page the call setup request until the MU2 replies.

3.5.2 Satellite Approach

In this algorithm, LHSs are used as the storage place instead of gateways.

3.5.2.1 Location Update Procedure

- ❖ Whenever a mobile user enters into the new IRA, he reports his User-ID and Home IRA-ID to the new IRA's LHS.
- ❖ The new IRA's LHS updates its visiting user table (VUT).

- ❖ The new IRA's LHS sends the visitor's Current IRA-ID to his LHS and updates the absent user table (AUT).

3.5.2.2 Call Setup Procedure

Let's assume that mobile user 1(MU1) tries to communicate with mobile user 2 (MU2) via satellite network. The nearest satellite of MU1 will be the stars satellite (S-SAT) of the connection path and that of MU2 will be the end satellite (E-SAT).

- ❖ MU1 sends a call setup request to S-SAT.
- ❖ S-SAT sends the call setup request to MU2's LHS
- ❖ If MU2's LHS finds his User-ID in the AUT,
 - ◆ Then, the nearest satellite from MU2's current IRA will be the E-SAT and the call setup request will be rerouted to the E-SAT.
 - ◆ Else, the MU2's LHS will be the E-SAT and no reroute is needed.
- ❖ Page the call request from the E-SAT.
- ❖ If MU2 replies,
 - ◆ Then, call setup is established.
 - ◆ Else, reroute the call setup request to next priority E-SAT and page the call setup request until the MU2 replies.

3.6 Simulation Construction

The network simulation models used in this thesis were built using two packages, BoNES Designer and SatLab, published by Cadence software. Designer is a top-down block-oriented network simulation package and SatLab is a satellite constellation simulation and optimization package. SatLab is used to communicate the relative positioning and visibility information of each network node to Designer, and comes with the Globalstar and

Iridium constellations built in. Since only Iridium system has inter-satellite link processing ability, Iridium constellation is the topology chosen for the simulation.

3.6.1 Satellite Approach

Figure 4 is a block diagram of the *Satellite Approach* simulation. Text labeled with an “M” is a memory variable, and the text labeled with an “P” is a simulation parameter set at runtime.

Detail parameter values and memory variable functions are explained in Appendix A. The simulation is composed of two main parts: positioning and communicating. Positioning

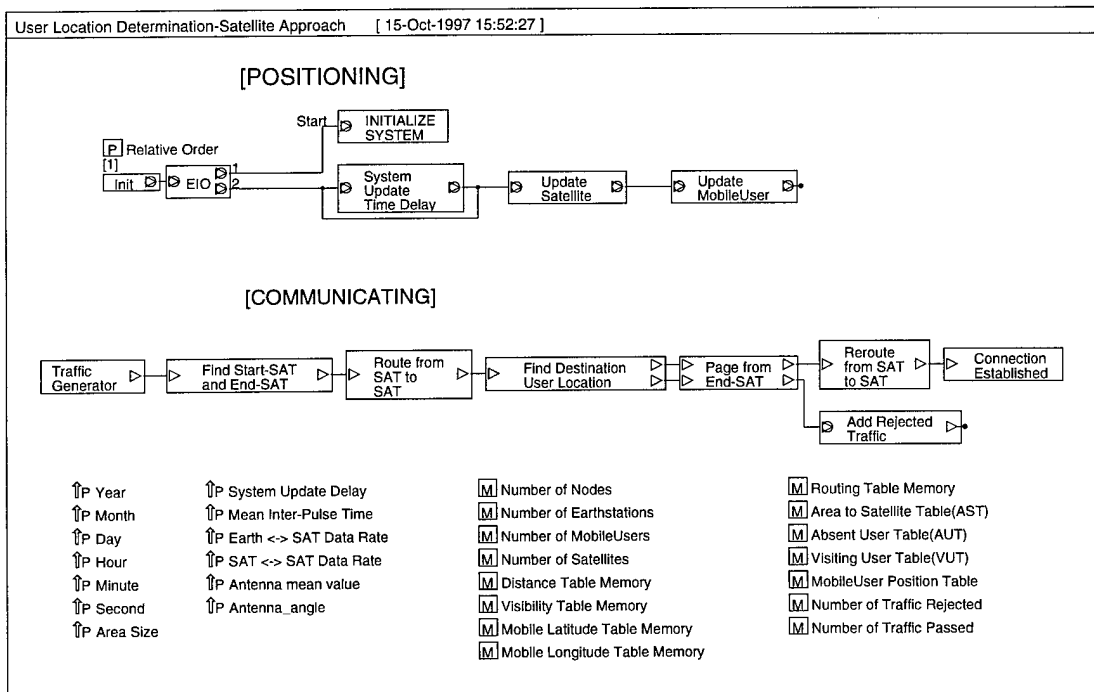

Figure 4 Top level block diagram of the Satellite Approach

part initializes all communication nodes (satellites, gateways, and mobile users) and updates their positions by requesting node information to SatLab simulator. Updating is performed every time period given by the parameter *System Update Delay* until the simulation finishes.

The communications portion of the model generates call request traffic based on a Poisson arrival rate, and routes call request traffic according to the proposed algorithm. After the call setup establishes, the call request traffic disappears. Detail explanation about simulation process is presented in Appendix A.

3.6.2 Gateway Approach

Figure 5 is a block diagram of the *Gateway Approach* simulation. The simulation initializing and node updating portions are the same as the *Satellite Approach*. The main difference in the communications portion is that the *Satellite Approach* first routes the call setup request message to destination user's LHS, which can be found in the AST, while the *Gateway Approach* first routes the call setup request message to destination user's home gateway (HG).

3.7 Data Collection

The purpose of this thesis is to compare the performance of user location determination algorithms that can be applied to LEO satellite network system. Two user location determination algorithms were presented in section 3.5. The two algorithms are very similar except that the physical location of user database is different.

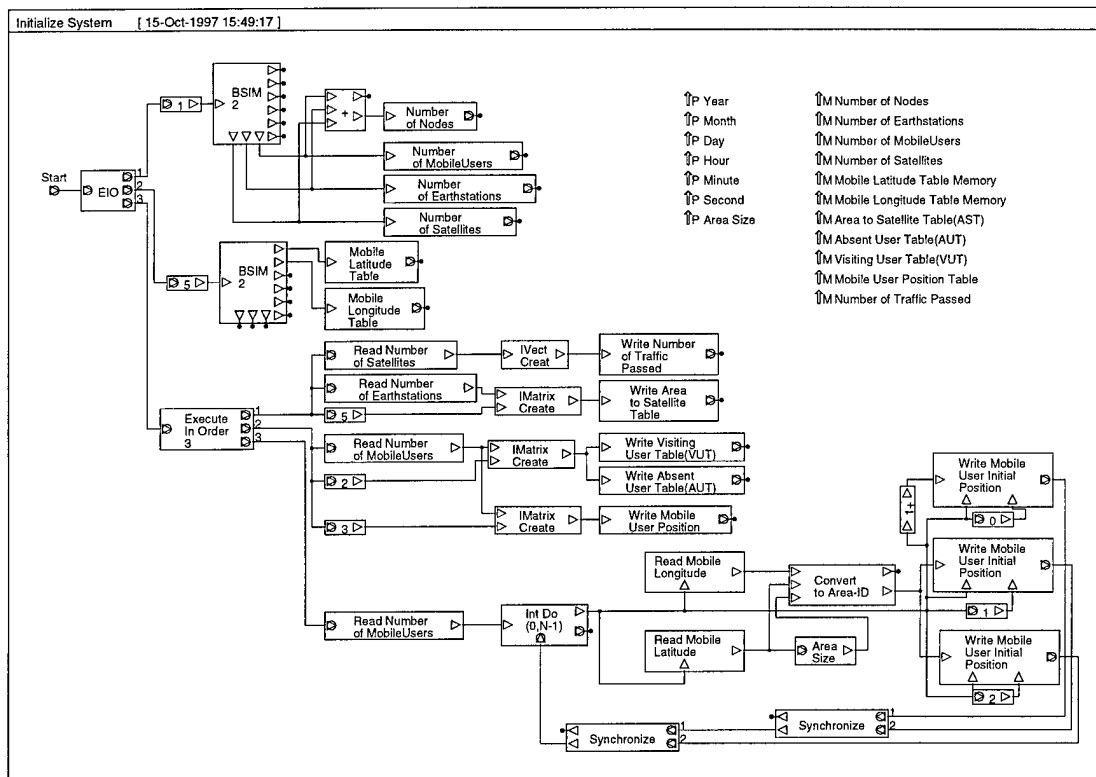

Figure 5 Top level block diagram of the Gateway Approach.

First, the most important comparison measurement of two algorithms is *Call Setup Delay* time parameter, which represents the total time taken for source user to find a destination user. This call setup delay is almost proportional to a *Hop-Count* (the total number of connections from node⁵ to node for each call setup procedure). Using these two parameters, we can compare the call setup speed of two algorithms.

Second, the total number of messages passing through each satellite during the simulation time is examined in order to calculate the processing load of each satellite. By

⁵ A node represents all sorts of terminals that consist of Satellite Communication Networks.

doing this, the message distribution for a given time period can be calculated and if there is any bottleneck point, it can be found with this measurement.

The last parameter examined is the memory requirement for each approach. Practically, the *Gateway Approach* doesn't have any problem about memory size for the user database. But the *Satellite Approach* has a limitation about on-board memory size. If the memory requirement of the worst case exceeds the ability of current satellite manufacturing technique, the satellite approach cannot be adopted no matter how it is a good approach.

3.8 Operational Assumptions

The simulation models developed for this thesis are constructed under a set of representative assumptions.

1. The area size for one unique registration area (IRA) was evenly divided and allocated according to the longitude and latitude range. This implies that the size of all registration areas is not same as for other areas. This is due to the fact that the length of longitude decreases as the magnitude value of latitude increases, the registration area near the North Pole (or South Pole) is smaller than that of the equator area. This policy was taken into account as the SatLab simulation program only sends the geographic coordinates of mobile users.

2. The source and destination users are selected randomly from the mobile users that are evenly positioned across the globe and move in similar fashion.

3. The user location update process is not precisely simulated as explained in the previous section. In real life, each mobile user has to update its location individually as it moves to new registration area. But in this simulation, the user location update process is performed with the fixed update interval time because of the limitation related with SatLab positioning request function. In SatLab program, node location update is performed by node group (satellite group, earth station group, and mobile user group) and single node cannot be updated individually. Thus, the message traffic related with the location update process is not taken into account for simulation construction.

4. Call setup delay is obtained by accumulating propagation delay and transmission delay. A further assumption is that there was no queuing delay, and no processing delay, during the entire simulation. Also, assumed is no user replying delay. However, the comparison of processing delay between two different approaches is discussed in Chapter 4.

5. The routing algorithm used in this simulation was provided by BoNES SatLab program builder. Since the matter of routing algorithm in LEO satellite network is beyond the scope of this research, the efficiency of this built-in routing function is not discussed. It should be understood that the routing algorithm using inter satellite links is one of the most important factor in the LEO satellite network system and must be developed and combined together with this research.

3.9 Verification / Validation

3.9.1 Designer BDE Verification

Each simulation was verified by BoNES Designer's built-in verification function, which implies that the simulation does not have any logical construction error. However, this built-in verification function cannot confirm whether the proposed ULD algorithms are correctly implemented to Designer simulations. For this reason, each call request was given a serial number and kept track of, using interactive simulation option. The result showed that each call request message was correctly routed to destination user and came back to the source user as explained in a previous section (3.5 User Location Determination Algorithm for Satellite Network System).

3.9.2 System Validation

Even though a lot of LEO satellite network systems are proposed and among them, Iridium system is planned to operate in 1998, detail system specifications are not published yet by the system providers. Thus, simulations constructed in this thesis are based on the published LEO satellite system proposals and research papers, and some constants (i.e. satellite data rates) taken from the Iridium proposal [FCC91].

3.10 Summary

In this Chapter, the public communications network (PCN) location management standard for North America area was presented and two ULD algorithms for satellite

network environment were derived. Also, simulations constructed to evaluate the two ULD algorithms were explained. In next Chapter, simulation results and analysis of the two ULD algorithms are discussed.

4. RESULT AND ANALYSIS

4.1 Simulation Execution

Two different simulations (one for *Satellite Approach* and one for *Gateway Approach*) were constructed and executed with three different area sizes for each simulation. With 20° of longitude and latitude interval, the earth can be divided to 162 areas. Also with 15° and 10°, it can be divided to 288 and 648 areas, respectively.

In the *Gateway Approach*, four different sets of gateway data were given and executed independently. In each data set, the global earth was divided by 6, 8, 10 or 12 main regions and a gateway positioned in the middle of each region regardless of geographical location. Thus, each simulation was operated with 6, 8, 10 and 12 gateways, respectively.

Each simulation ran for 6000 sec of simulation time, which is the same as one orbital period of Iridium satellite. During one orbit period, each satellite can have a same opportunity of having message traffic in terms of latitude variation, and this can provide more accurate message distribution analysis among satellites.

During the simulation process, relative node position information between nodes are calculated and saved to memory by the SatLab simulation program. The size of memory for this table requires (number of satellites + number of mobile users + number of area)² data entries. In the case of 162 area simulation, 248,004 values must be calculated every 60 seconds.

4.2 Call Setup Performance Analysis

4.2.1 Average Delay

Figure 6 shows the average call setup delay of the *Satellite Approach* and *Gateway Approach*. When the area size was the same value, average call setup delay of *Satellite Approach* was 0.022 seconds less than that of *Gateway Approach*. The main reason of this 0.022 seconds time difference came from the different routing path between the two approaches. This implies that the routing path of *Gateway Approach* is longer than that of *Satellite Approach*.

Also in both approaches, call setup delay decreased as the number of areas increased. This result came from the accuracy of E-SAT selection. In other words, the E-SAT was selected more accurately when the total number of areas was large. Table 4 shows that the

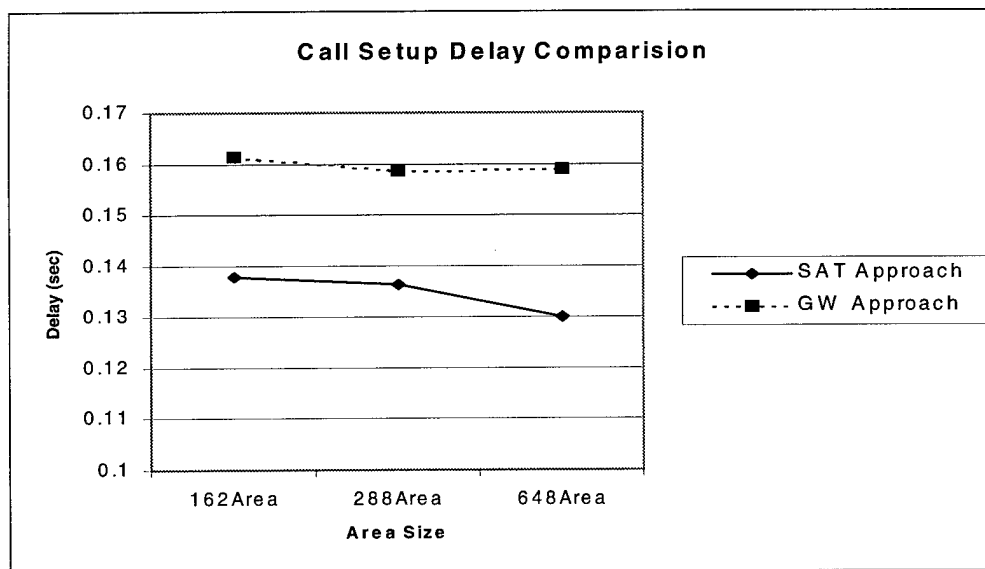

Figure 6 Call Setup Delay vs. Area Size

Table 4 Probability of satellite selection as the number of area varies

Priority	SAT Approach			GW Approach(6GW)		
	162Area	288Area	648Area	162Area	288Area	648Area
Priority=1	91.071%	95.461%	97.375%	90.830%	95.444%	97.491%
Priority=2	6.751%	3.891%	2.497%	7.159%	3.615%	2.447%
Priority=3	2.078%	0.599%	0.128%	1.951%	0.891%	0.063%
Priority=4	0.100%	0.050%	0.000%	0.060%	0.050%	0.000%

distribution of selected satellites according to the area size. In this table, priority is defined as the minimum order of distance between the center position of each area and satellites that is orbiting within a line of sight from that area.

According to Table 4, in the case of the *Satellite Approach*, 91.071% of call setup requests were established at first E-SAT selection with 162 area division, while 97.375% of call setup requests were established at first E-SAT selection with 648 area division. This implies that 6.304% of more call setup requests with 162 area division had to be rerouted to next priority E-SAT in order to find destination user. The same result occurred for the *Gateway Approach*.

Another factor that can vary the call setup delay for the *Gateway Approach* is number of total gateways in the system. Figure 7 shows that the call setup delay decreases as the number of gateway increase when the area size is the same. This result reflects that the routing path of the call setup request can be shortened as the number of gateway increases.

From a viewpoint of call setup delay, the *Satellite Approach* outperforms the *Gateway Approach* and detail area allocation results in better performance than rough area allocation.

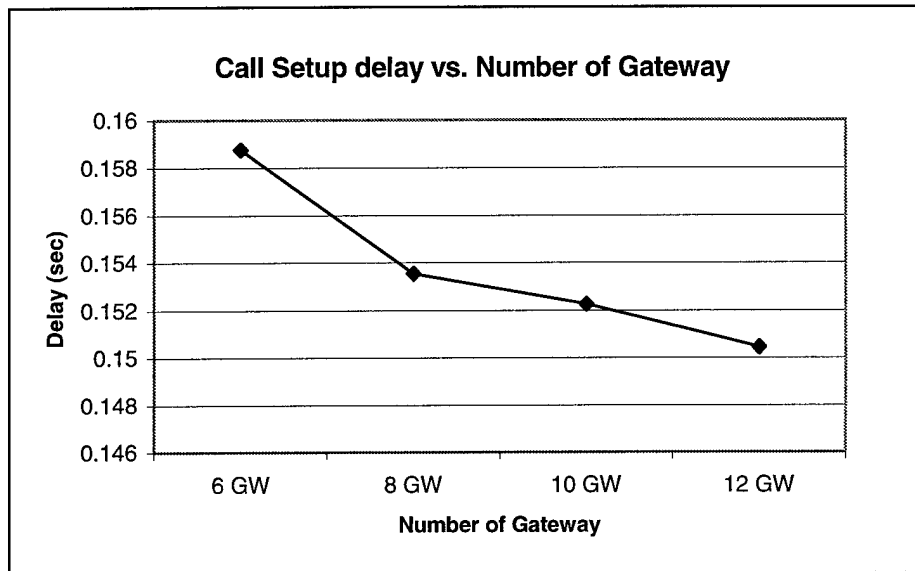

Figure 7 Call Setup Delay vs. Number of Gateway

Also in the case of the *Gateway Approach*, call setup time with a large number of gateways was faster than with a small number of gateways.

4.2.2 Average Hop-Count

Number of hops during a call setup process is almost proportional to the call setup time in average case. However, more examination was taken into account in order to find the difference in routing path. Figure 8 shows the average number of hop-count during all call setup process. According to the Figure 8, average hop-count of the *Satellite Approach* was almost three hops less than that of *Gateway Approach*. And in both approaches, hop-count decreased as the number of areas increased. Also, when the area size is the same, average Hop Count decreases as the number of gateway increases (Figure 9).

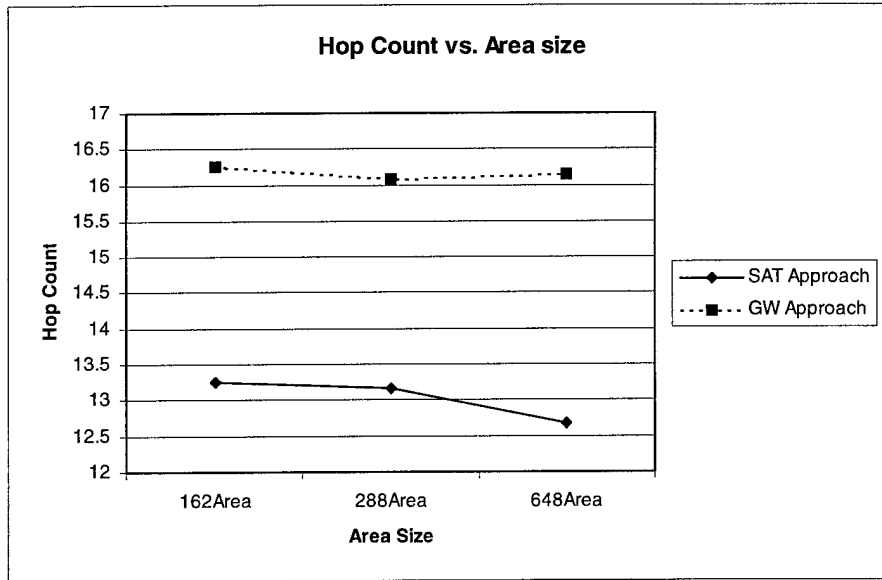

Figure 8 Hop Count vs. Area Size

By looking at the *Gateway Approach* algorithm, it is expected that at least two more hops would be required compare to the *Satellite Approach*. This is because, in the *Gateway Approach*, the call setup request must downlink to the gateway in order to access the user location database and uplink to the satellite again.

The remaining difference in the setup delay (excluding 2 hop-count) came from the route discrepancy between two approaches which can vary according to mobile users moving pattern. If mobile users are primarily roaming around their home area, the *Gateway Approach* will have a higher hop count. If mobile users are primarily roaming around the *Gateway Area*, the result will be reversed. If mobile users are traveling far from their home area or gateway, the difference will be decreased.

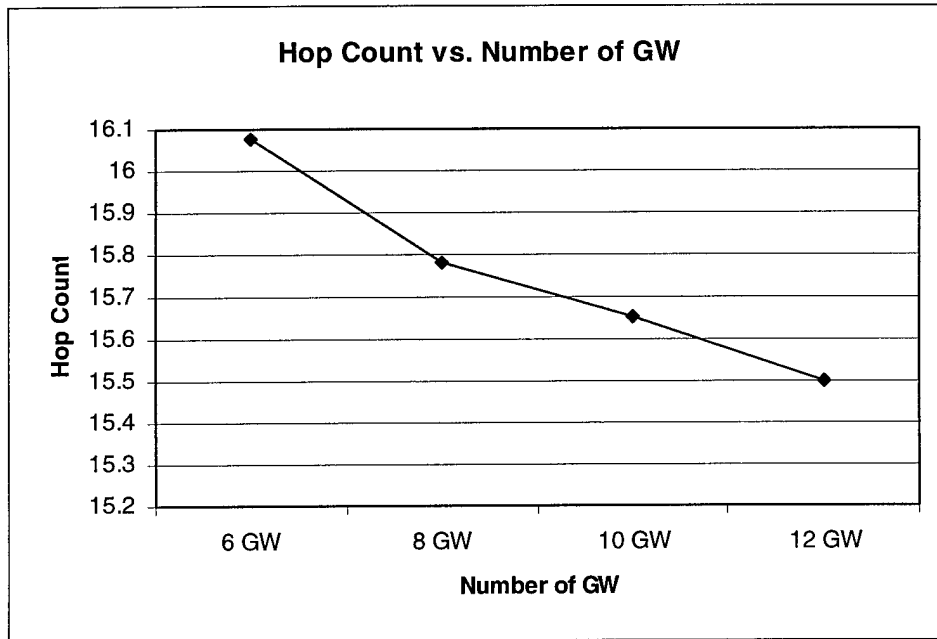

Figure 9 Hop Count vs. Number of Gateway

4.2.3 Overall Performance

From the results in previous sections, the *Satellite Approach* showed better performance than the *Gateway Approach* in terms of call setup delay and number of hop-count. In the case of the *Gateway Approach*, call setup delay was decreased as the number of gateways increased.

4.3 Memory Requirement for the Satellite Approach

Whereas the *Gateway Approach* doesn't have any limitations associate with memory size for the user information database, the *Satellite Approach* is limited in its on-board memory capacity. This requires a more optimized user information database structure in order to minimize the memory requirement of the *Satellite Approach*. In other words, satellites only

have to store minimum data related with user location and the rest of the information (e.g. user profiles, billing information, etc.) still can be stored in gateways.

4.3.1 Area to Satellite Table (AST)

Each satellite updates the AST using an embedded calculating function and the size of this table will be (*number of areas * minimum number of satellites visible from one area * bit size of SAT-ID*). From the Table 4 in previous section, in case of Iridium satellite network system, four nearest satellites from the center of IRA are required for two different area allocation simulations (162 IRA and 288 IRA) and three nearest satellites are required for one simulation (648 IRA). Satellite-ID requires only 7 bits in order to distinguish 66 satellites.

For example, in the case of 162 area division with 66 Iridium satellites, each IRA requires four nearest satellite table. These values yield total size of 4536 ($162 \times 4 \times 7$) bits for a 162-area division. Also, for the 288-area and 648-area divisions, total size of 8064 ($288 \times 4 \times 7$) bits and 13608 ($648 \times 3 \times 7$) bits result, respectively. Thus the maximum size needed for AST is at most 1701 bytes and this value is almost negligible.

4.3.2 Absent User Table (AUT)

The size of AUT is totally dependent on the number of subscribers, user mobility pattern, geographical location, and geopolitical position. And at this point, even if a prediction can be made of the number of subscribers, the mobility pattern cannot be

achieved. Thus, the worst case of scenario is applied to determine the maximum memory requirement for each satellite.

AUT has two fields, User-ID and Area-ID. Thirty bits of User-ID can distinguish a maximum of 1 billion of users and 10-bits of Area-ID can provide 1024 unique area code. Let's suppose that 10 millions of world-wide subscribers, which is the declared target of Iridium system [Gav97], use Iridium phones and all the users are currently out of their Home Area. Let's suppose all the users were originally registered to one Home Area in worst case, one Home satellite contains all the User-ID in its AUT. This worst case of one AUT size turns out to be less than 50 Mbyte (10million*40bit) for one satellite.

4.3.3 Visiting User Table (VUT)

The total number of absent users over the globe is always the same as total number of visiting users. So, the worst case is that all the mobile users are visiting one area from all over the world and the size of VUT will be the same as worst case of AUT.

4.3.4 Total Memory Size Required

The size of AST is small in comparison to the size of AUT or VUT. And also the total size of AUT and VUT in one satellite can never exceed the total number of mobile users. Thus the maximum memory size required for satellite approach turns out to be 50 Mbyte of memory.

4.4 Processing Delay Associated with Data Access

Iridium is currently the only LEO satellite system having on-board processing and routing capability through the inter-satellite links. The processing delay at each intermediate satellite will be the same regardless of user location determination algorithm. The difference in processing delay happens when the call setup procedure tries to access AUT or VUT. In most case, the seek time increases as the size of database increase.

In the *Gateway Approach*,

$$\text{Average size of AUT} = \text{Number of Mobile Users} / \text{Number of Gateways} \quad (1)$$

, and in the *Satellite Approach*,

$$\text{Average size of AUT} = \text{Number of Mobile Users} / \text{Number of Satellites} \quad (2)$$

In the case of 6 gateways with 66 Iridium satellites, one gateway will have eleven times larger size of AUT than one satellite. This implies that the AUT seek time of gateway is not faster than that of satellite.

4.5 Message Traffic Distribution Over the Satellite

Figures 10 and 11 show the average number of call setup messages at each orbit during one orbital period of simulation time in the *Satellite Approach* and *Gateway Approach*, respectively. In the *Satellite Approach*, the average number of messages passed through one orbit was 1953.67 messages and standard deviation was 131.85 messages, whereas in the *Gateway Approach*, average and standard deviation was 2017.17 messages and 285.2097

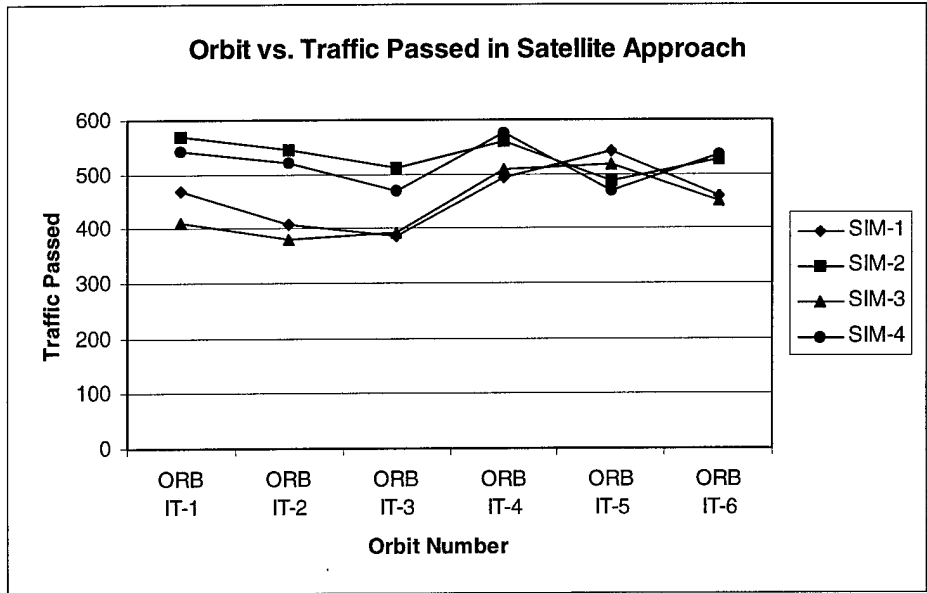

Figure 10 Message Distribution over Orbits-Satellite Approach

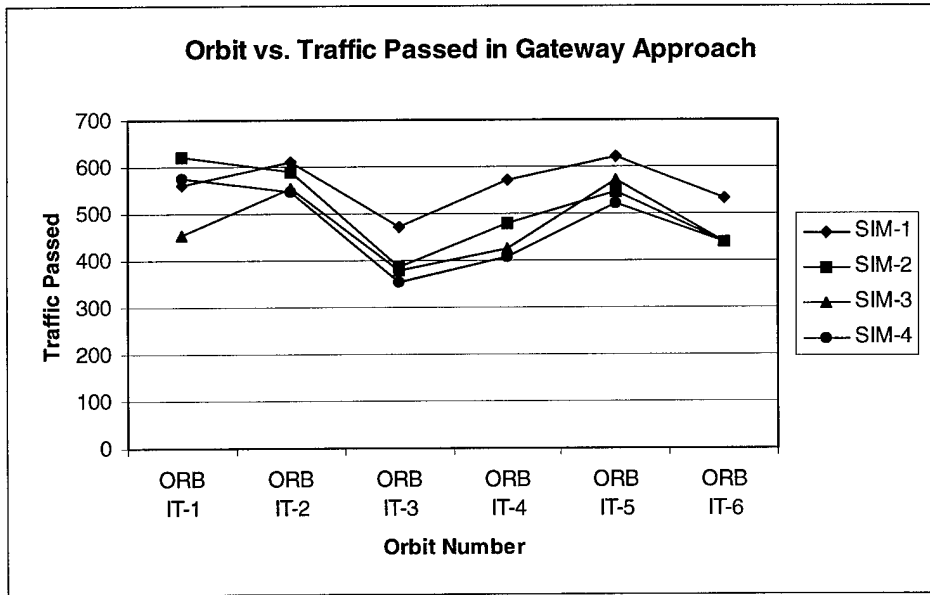

Figure 11 Message Distribution over Orbits-Gateway Approach

messages, respectively. This result implies that message traffic was more evenly distributed in the *Satellite Approach* than it did in the *Gateway Approach*.

In the *Gateway Approach*, every call request must pass through the gateway for the user location database access and this makes the satellite near by gateways always busy. Figure 12 shows that the orbit tracks and gateway positions during the simulation time. Orbit-1, Orbit-2 and Orbit-5 are passing by gateways and this is consistent with the result from Figure 12.

4.6 Summary

In this Chapter, the simulation result of two ULD algorithms proposed in Chapter 3 was presented. And requirements for the *Satellite Approach* was examined. The *Gateway Approach*

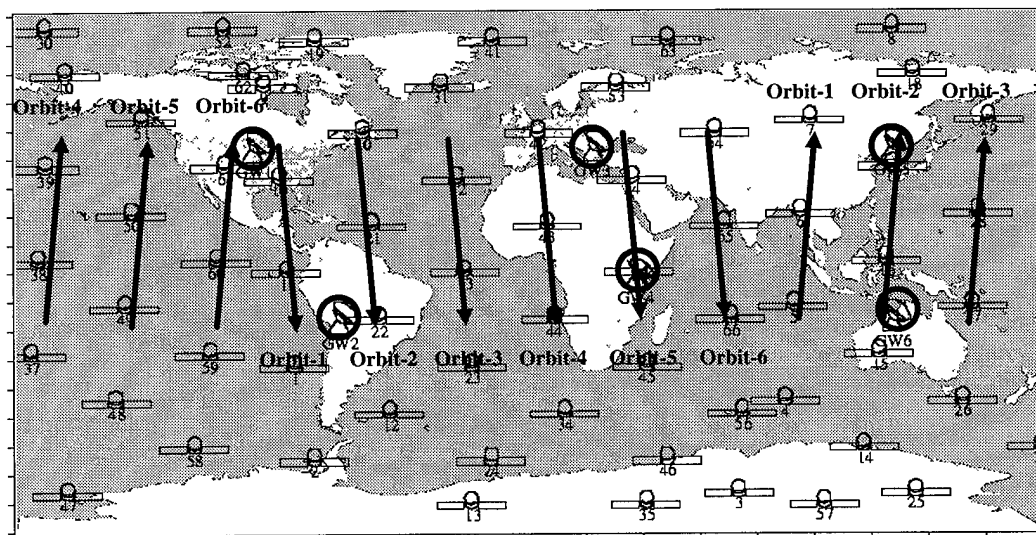

Figure 12 Relationship between Orbits and Gateways

currently has no limitation in implementing the system while the *Satellite Approach* have minimal limitations in the memory space and computational ability of each satellite. However, the *Satellite Approach* outperforms than the *Gateway Approach* in terms of fast call setup time and no message congestion.

If the 50Mbyte of memory space and computational ability for orbital positioning calculation are feasible in current satellite manufacturing technique, the *Satellite Approach* is the most likely ULD scheme for the satellite network systems .

5. CONCLUSIONS

5.1 Overall Performance Comparison

As discussed in Chapter 4, simulation results showed that the *Satellite Approach* result in average of 0.022 seconds faster call setup time and average of 2.91 less Hop Count than the *Gateway Approach*. In case of the *Gateway Approach*, 12-gateway simulation showed average of 0.012 seconds faster call setup time than 6-gateway simulation. In the *Satellite Approach*, call setup request accesses the user location information from LHS, while in the *Gateway Approach*, call setup request accesses the user location information from Home Gateway, which requires on average two more hops to travel compare to the *Satellite Approach*. However, this can be possible only if each satellite has enough memory space for AUT and VUT and also have to handover the databases to next satellite. This requirement may increase satellite overhead in terms of computational ability and memory capacity and make it harder to maintain the databases.

Another advantage of the *Satellite Approach* is that message traffics are more evenly distributed over the satellites compare to the *Gateway Approach*, which can prevent message congestion on particular satellites. The message congestion decreases as the total number of gateways increases, and this can cause more service cost to subscribers.

One important nature of the *Satellite Approach* is that it has a higher survivability than the *Gateway Approach* in case of system loss. For instance, if we lose a gateway which contains all the user database in North America, the whole North American area becomes out of service

until the gateway is recovered. In case of the *Satellite Approach*, however, only a footprint area of one satellite will be out of service only for the visible time⁶ of non-operating satellite from a view point of one single user. Most of users may not perceive this non-operation time, while some of heavily dependent users feel inconvenience for that period of time.

5.2 Future Research

This thesis is based on the assumption that all the AUT and VUT are maintained by satellites, and the user location information tables are gracefully passed to correct satellites which need that information. This assumption can be solved by the following procedure.

First, we have to analyze the satellite network topology and formulate the topology change. By doing this, we can calculate the exact position of each satellite at a given time.

Second, we have to build geopolitical Iridium Area Code database in order to map a satellite to multiple areas. This gives satellites area information which will have to be processed and updated. Also, each satellite can pass its database to the correct satellite. Some Iridium Area cannot be covered by one satellite, and in this case, all the satellites covering one particular area have to have same user databases for that area.

One more case not discussed in this thesis is that of the call setup time between satellite network and terrestrial network like PSTN system. If we try to communicate with terrestrial networks, the algorithms suggested in this paper will become more complex and cannot

⁶ In case of Iridium satellite network system, the visibility time of one satellite is about 11.1 minutes.

work without gateways. Thus, we need to develop both ways to maximize the network efficiency and flexibility.

5.3 Conclusion

In this thesis, two procedures for user location determination were introduced. Delay performance for the two procedures was analyzed using network simulation program, BoNES Designer and SatLab. The *Satellite Approach* used satellites for database storage, while the *Gateway Approach* used gateways. Gateways are also needed for the connection between PSTN and satellite network and for this reason, many countries are trying to build the Iridium gateway in their area. But, the number of gateways planned is not uncertain yet, and also it is not known whether all the gateways will be used for user location database storage, or not. If current satellite manufacturing technology permits, the *Satellite Approach* will be the best way to manage user location databases. Memory requirements and computational ability are not big obstacles at this time.

APPENDIX A

Detailed Simulation Definition

A.1 Satellite Approach

Figure 13 is the top level block diagram of Satellite Approach. The six temporal parameters in the bottom left corner are used to set the starting time of the simulation. These values were set to 01/01/1997 10:30:00 in this simulation and can be set to any arbitrary values.

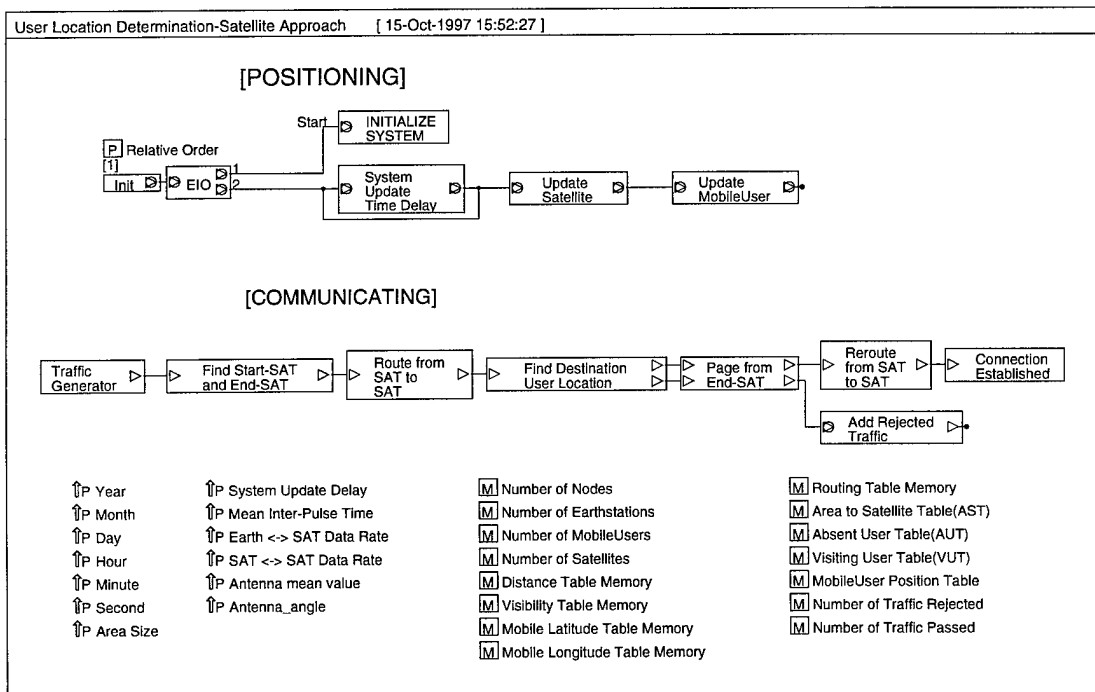

Figure 13 User Location Determination-Satellite Approach

The parameter *Area Size* is used for changing the size of geographical area that has its unique Iridium area code. In this simulation, each area size is set to 10, 15, or 20 degree of longitude and latitude range, which implies that the area size is not equally divided by the absolute value of each area, but divided by earth coordinate value. Thus, absolute size value of polar area is smaller than that of equator area, and this method was used because of difficulties in building a geopolitical area database at this point.

The parameter *System Update Delay* in the second column is the time interval between every system updating procedures (satellite update and mobile user update). In this simulation, the value is set to 60 seconds. The parameter *Mean Inter-Pulse Time* is the mean interval time value used in Poisson traffic generator. This value is set to 1second. The parameter *Earth↔SAT Data Rate*, *SAT↔SAT Data Rate* are set at 12.5 Mbps, and 25Mbps, based upon the data rates specified in the Motorola FCC filing for Iridium [FCC91]. The parameter *Antenna mean value* and *Antenna_angle* are used for generating Cost Matrix, which is again used for generating a routing table, and set to 78.5° and 45°, respectively.

The memory variable *Number of Nodes* is calculated in the Initialize System block. It is the sum of the *Number of MobileUsers*, *Number of Satellites*, and *Number of Earthstations* variables, which are passed into the simulation from the SatLab program based on the constellation loaded.

Distance Table Memory, *Visibility Table Memory*, and *Mobile Latitude and Longitude Table Memory* are also passed into the simulation by SatLab and reflect the current physical

locations of the entities in the constellation. These variables are used by the routing protocol to calculate *Routing Table Memory*, which is a matrix of next-hops for every possible source and destination in the network.

Area to Satellite Table(AST), *Absent User Table(AUT)*, and *Visiting User Table(VUT)* are the tables used for finding user locations and already explained in Chapter 3. *Mobile User Position Table* is a profile of all mobile users, which is used for keeping track of the position of all users. *Number of Traffic Rejected* and *Passed* is used to check the correctness of simulations.

The simulation is divided by two main parts, POSITIONING and COMMUNICATING. POSITIONING part starts first because the internal parameter *Relative Order* is set to high priority. *INITIALIZE SYSTEM* block is executed for the first time and Figure 14 shows the detail block diagram of *INITIALIZE SYSTEM* block.

This block is executed only once during the whole simulation period. It receives the number of satellites, mobile users, and earthstations from the SatLab program and calculate the total *Number of Nodes*. Then, it initializes all the memory valuables used in the simulation. In the end, it creates *Mobile User Position Table* using *Mobile Longitude/Latitude Table Memory*.

After initializing the system, *Update Satellite* and *Update MobileUser* block is executed without any delay, and these two blocks are executed every 60 seconds until the simulation finishes. Figure 15 and Figure 16 shows the detailed block diagram of *Update Satellite* and *Update MobileUser* block. In *Update Satellite* block, the system first receives new satellite location data from the SatLab program and generates a new routing table, which is saved to

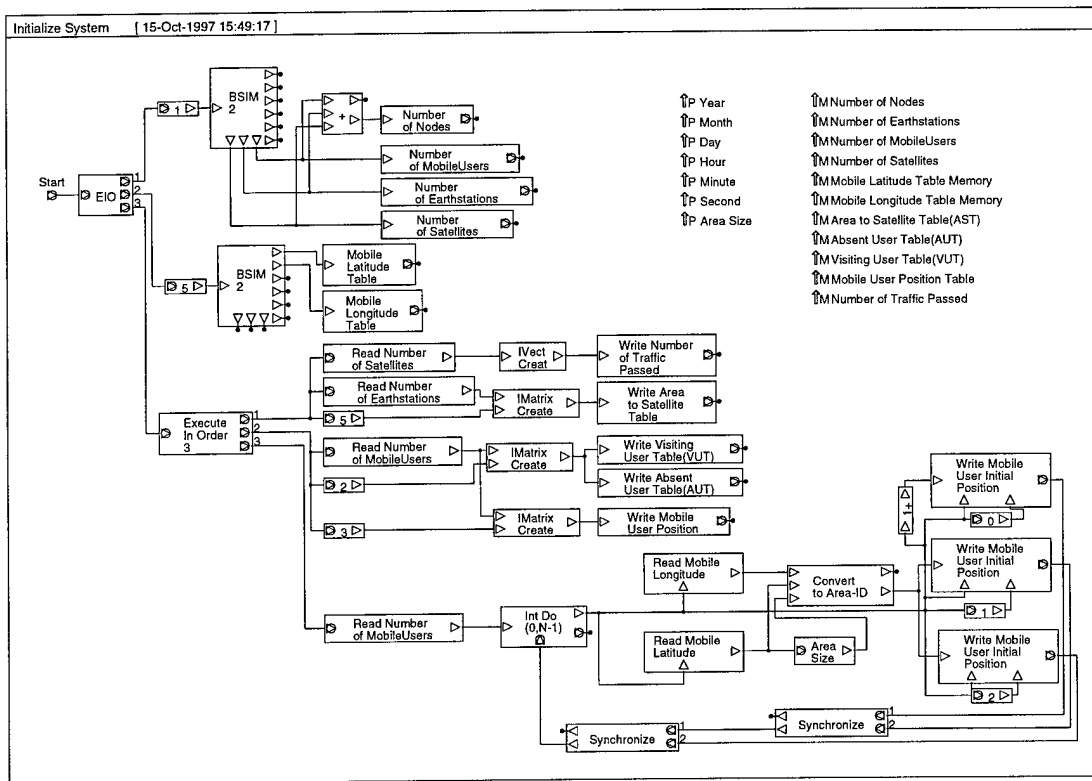

Figure 14 Initialize System

Routing Table Memory. After that, this block calculates the closest five satellites from each Home Area and save the results to new *Area to Satellite Table(AST)*.

In *Update MobileUser* block (Figure 16), all the mobile users' new location coordinates are sent to this block from the SatLab program, and converted to area code in which each mobile user is located. If the area code of the new position is different from that of the previous position, AUT and VUT are updated with a new area code.

Figure 17 shows the detailed block diagram of *Update AUT* block. It writes the new area code to AUT unless the new area code is same as the mobile user's Home Area code. If the

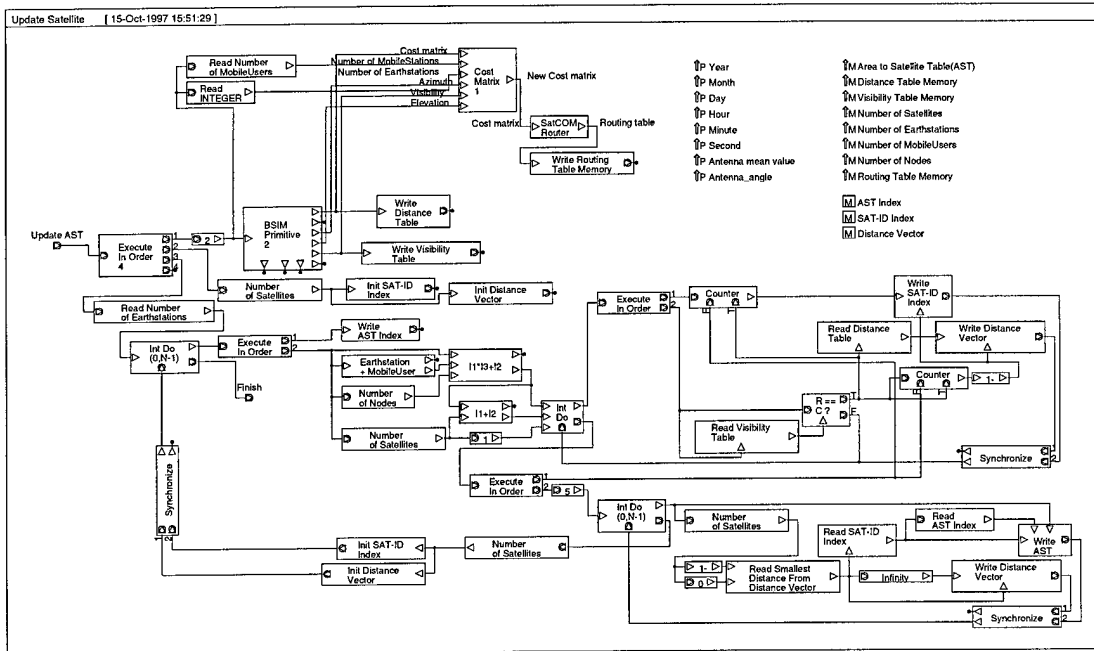

Figure 15 Update Satellite

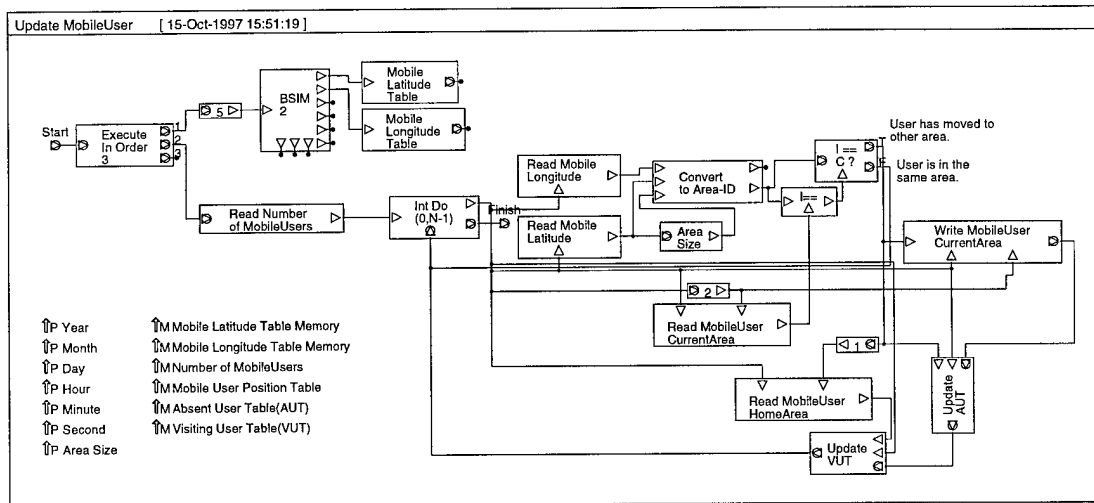

Figure 16 Update Mobile User

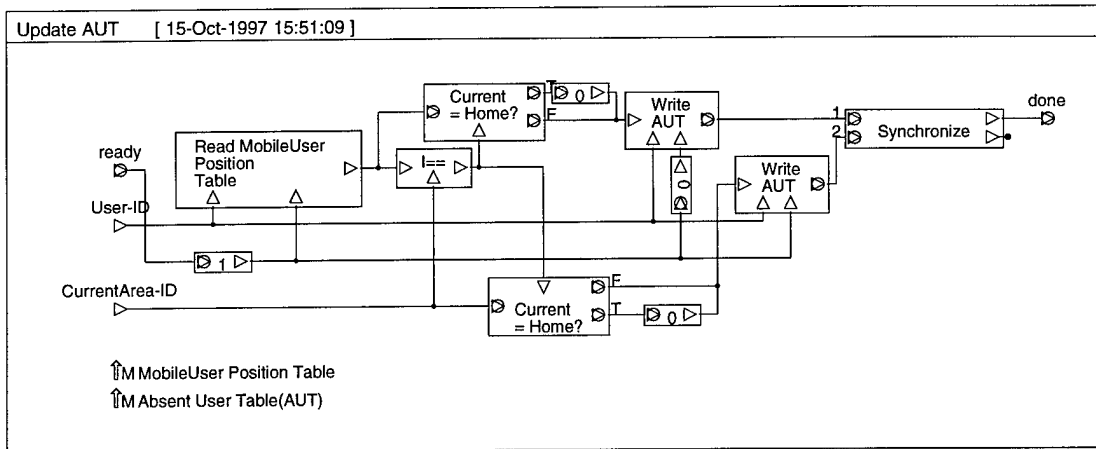

Figure 17 Update AUT

mobile user comes back to its Home Area, the current area field will be set to 0. Figure 18 shows the detailed block diagram of *Update VUT* block. It writes the mobile user's Home Area code to VUT unless the mobile user's Home Area code is same as the visiting area code.

Once the first iteration of updating procedure finishes, the COMMUNICATING part

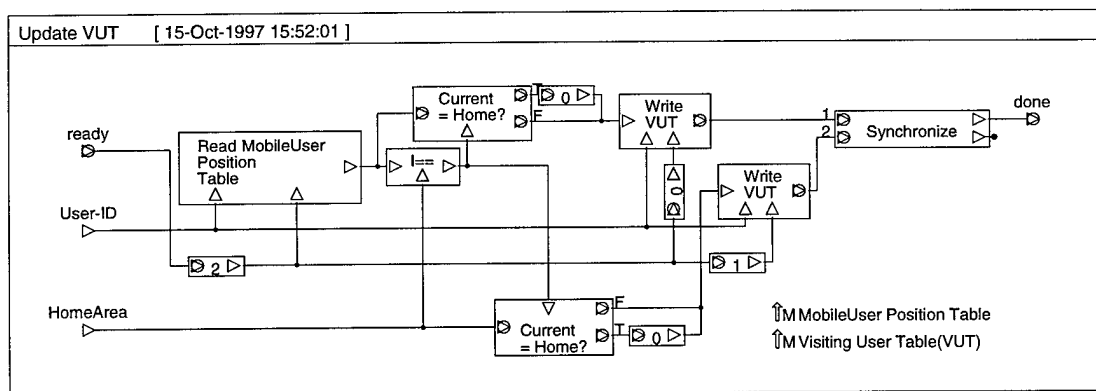

Figure 18 Update VUT

begins execution. Figure 19 shows the detailed block diagram of *Traffic Generator* block.

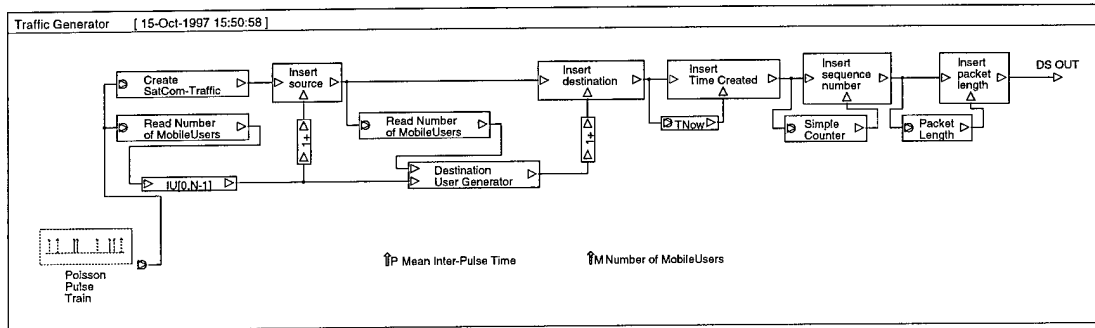

Figure 19 Traffic Generator

First it chooses a source user and then, it chooses a destination user which is not the same as a source user. Figure 20 shows the detailed block diagram of *Destination User Generator* block. Once source and destination User-Id are selected, call request time (Tnow), sequence number, and packet length are inserted for the simulation analysis purpose.

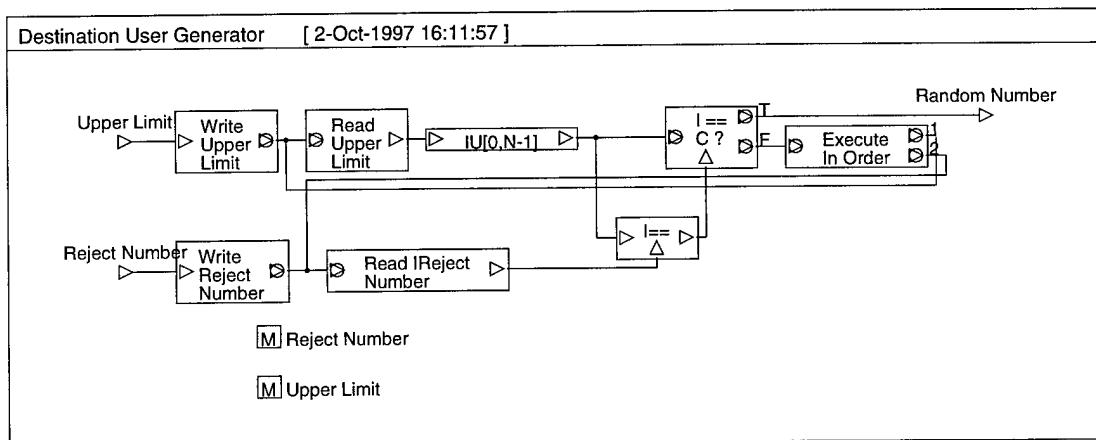

Figure 20 Destination User Generator

Then call setup request is sent to *Find Start-SAT and End-SAT* block. Figure 21 shows the detailed block diagram of *Find Start-SAT and End-SAT* block. In this block, the source user's call request is connected to the nearest satellite from itself (Start-SAT) and at this point, the transmission delay and propagation delay are calculated and the call setup request is delayed according to the calculated value.

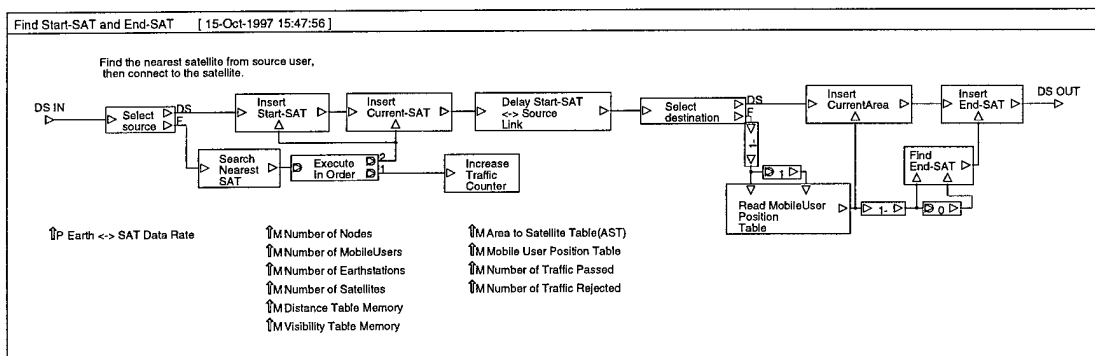

Figure 21 Find Start-SAT and End-SAT

Figure 22 is the detailed block diagram of *Search Nearest SAT* block. It checks the

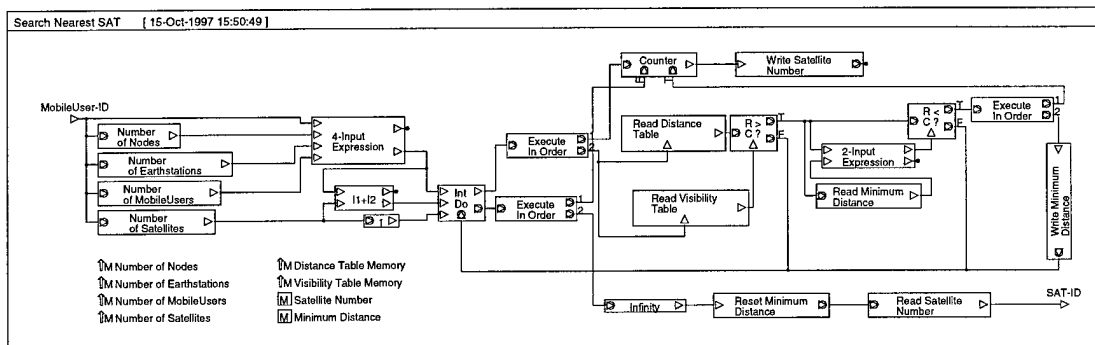

Figure 22 Search Nearest SAT

distance between the source user and all the satellites visible from the source user. The mobile then picks the nearest satellite. Figure 23 is the detailed block diagram of *Delay Start-SAT ↔ Source Link* block. Propagation delay between source user and Start-SAT can be obtained by dividing the distance between two nodes by the speed of light. Also, transmission delay can be calculated by dividing the number of bits to transmit by data rate of the link. As soon as the call setup request arrives at the Start-SAT, it looks up the AST in

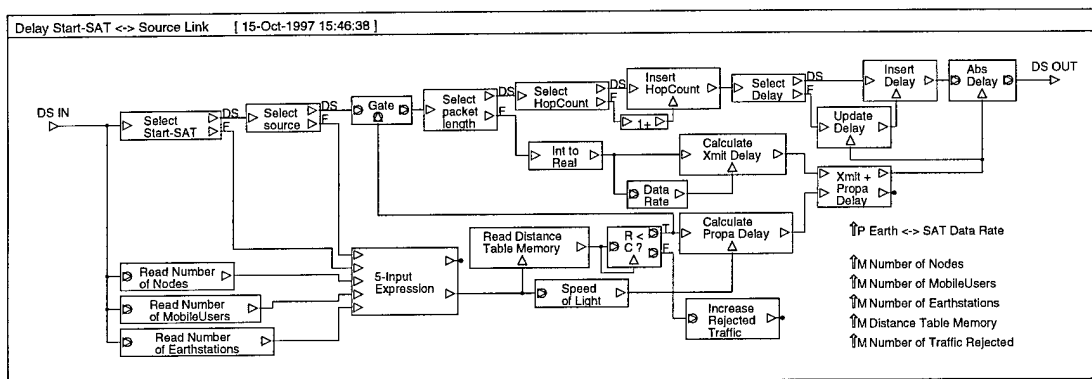

Figure 23 Delay Start SAT ↔ Source Link

the satellite memory and find LHS of destination user' Home Area and this satellite will be the End-SAT.

Having decided the End-SAT, the call setup request is routed to the End-SAT by propagating signals through inter-satellite links. Figure 24 shows the detailed block diagram of *Route from SAT to SAT* block. During the call request routing, the propagation and transmission delay is applied and total delay time is accumulated in each step. Figure 25

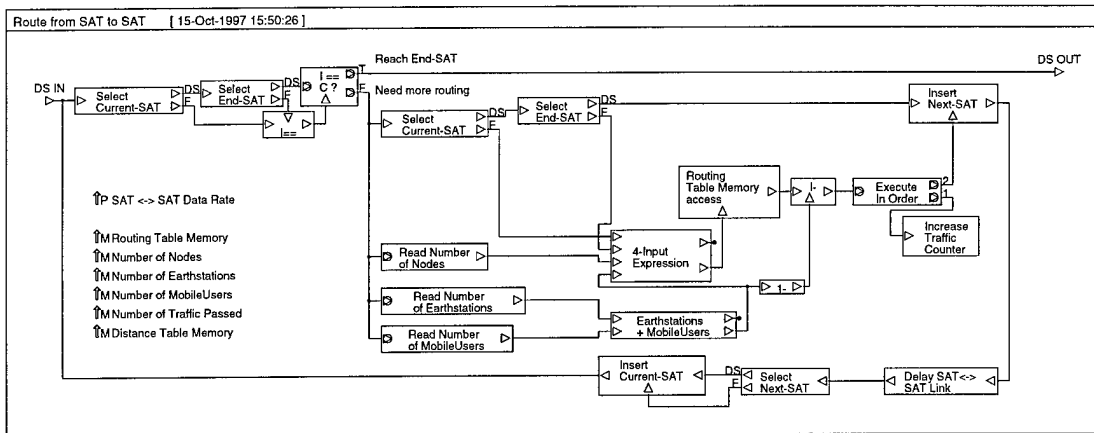

Figure 24 Route from SAT to SAT

shows the detailed block diagram of *Delay SAT ↔ SAT Link* block and this is exactly same as Figure 23 except the Data Rate between nodes.

After the call setup request arrives at the End-SAT of destination user, it can find the destination user's current location from the AUT. If the destination user is not in his/her Home Area, the call setup is rerouted to the new End-SAT which is the nearest satellite

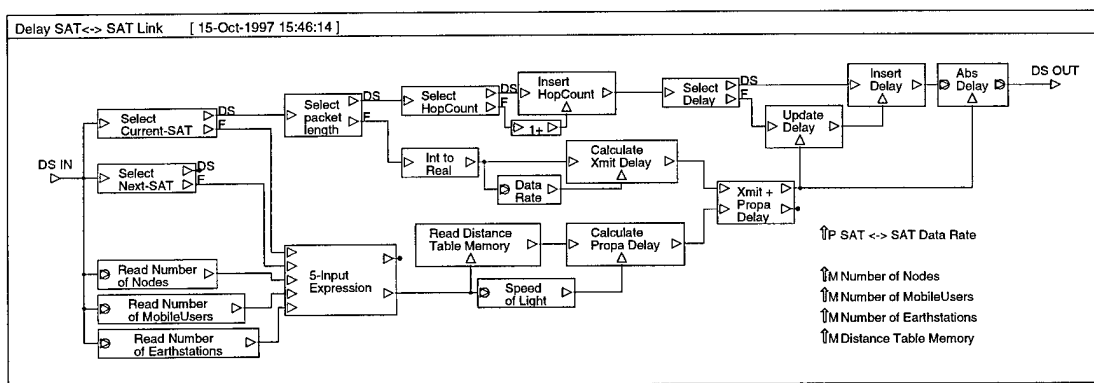

Figure 25 Delay SAT ↔ SAT Link

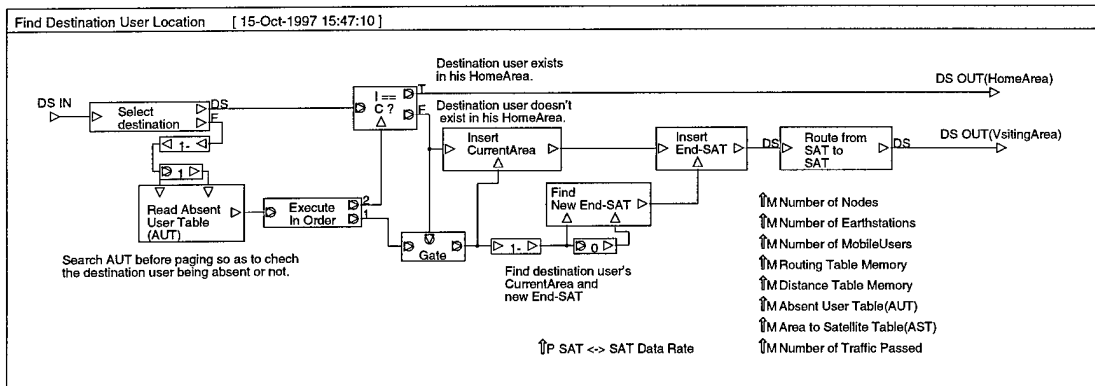

Figure 26 Find Destination User Location

from destination user's Current Area. Figure 26 shows the detailed block diagram of *Find Destination User Location* block.

Finally, the call setup request signal arrives at the satellite which is indicated in the AUT of a destination user. Figure 27 shows the detailed block diagram of *Page from End-SAT*. In this step, if the destination user is in his or her Home Area, he or she pages a call signal. If the destination user is in visiting area, however, he or she tries to access the VUT in End-

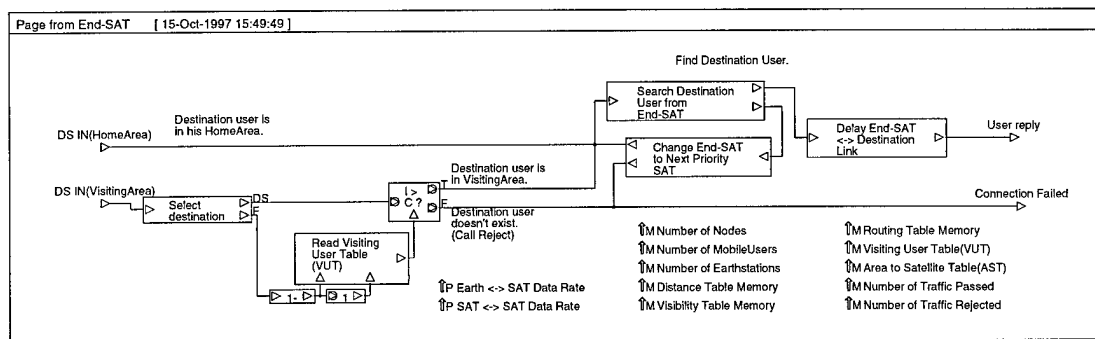

Figure 27 Page from End-SAT

SAT and then pages a call signal only if the destination User-ID exist in that table. If the destination user exists under the footprint area of End-SAT, he or she replies, but if the destination user does not exist, the call setup request is rerouted to next priority End-SAT according to AST. This rerouting procedure is repeated until the destination user is found or it searches all the End-SAT in AST.

Figure 28 and 29 shows the detailed block diagram of *Search Destination User from End-SAT* block and *Change End-SAT to Next Priority SAT*, respectively. In Figure 28, the destination user's existence is decided by checking the visibility between the End-SAT and destination user. The simulation assumes that destination user replies without any delay only if he or she is visible from End-SAT. In Figure 29, the End-SAT is replaced by next priority satellite indicated in AST and the call setup request is routed to the new End-SAT. If the call setup request signal cannot find the destination user after searching the lowest priority

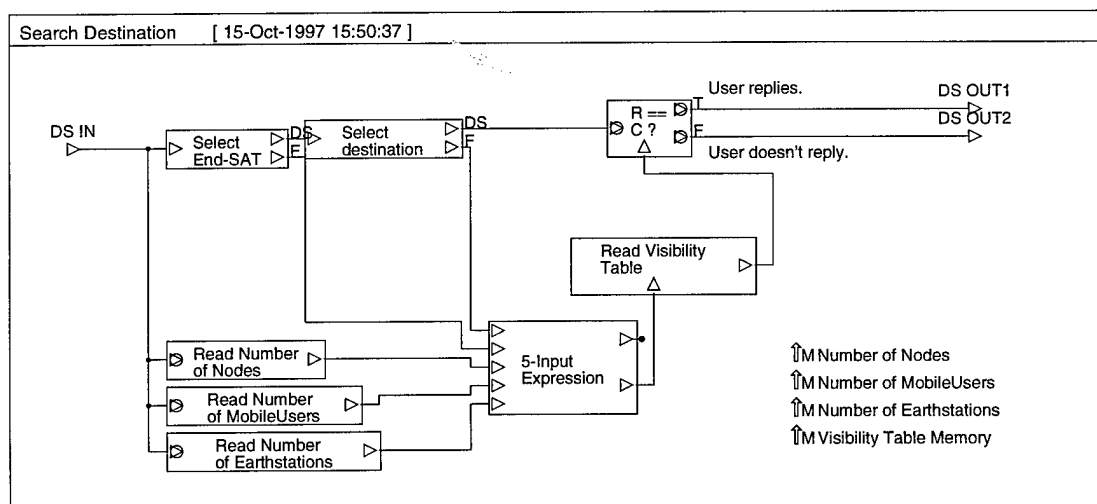

Figure 28 Search Destination

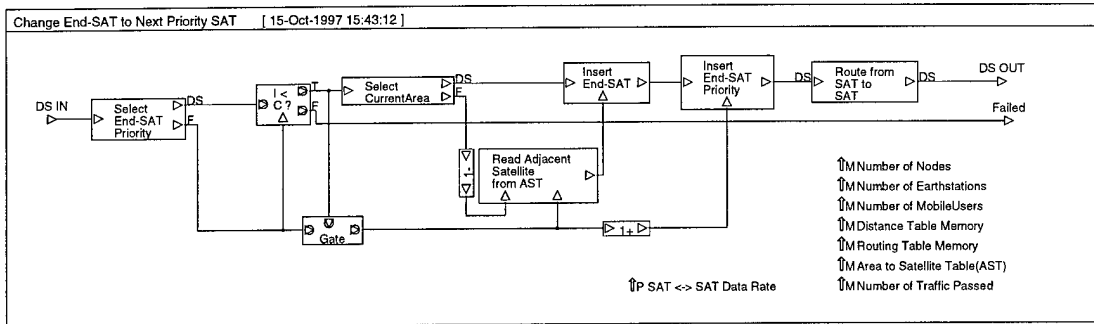

Figure 29 Change End-SAT to Next Priority SAT

End-AT in AST, the call setup request is declined and stop searching destination user. Once the call setup request find the destination user, it calculates the round trip delay between End-SAT and destination user and is delayed in *Delay End-SAT ↔ Destination Link* block (Fig30).

After the call setup request succeeds in finding destination user, call setup success signal is rerouted to the original Start-SAT to finish the call setup process. Figure 31 shows the

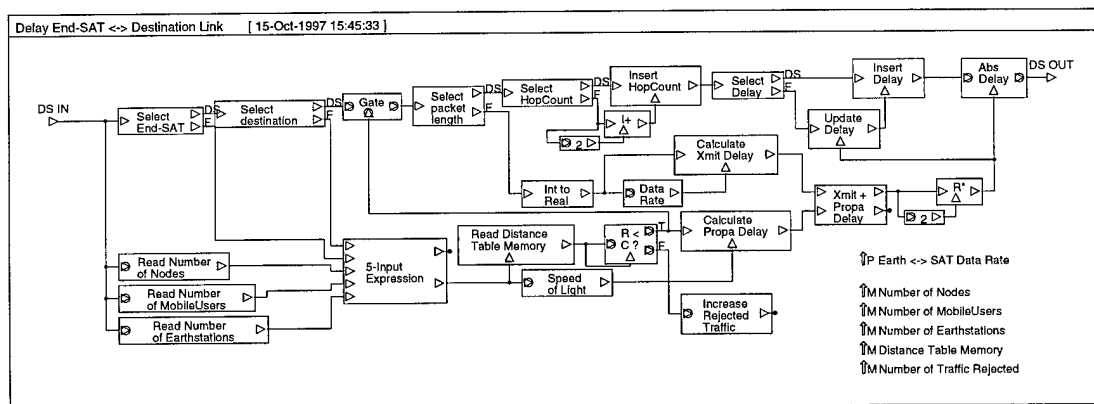

Figure 30 Delay End-SAT ↔ Destination Link

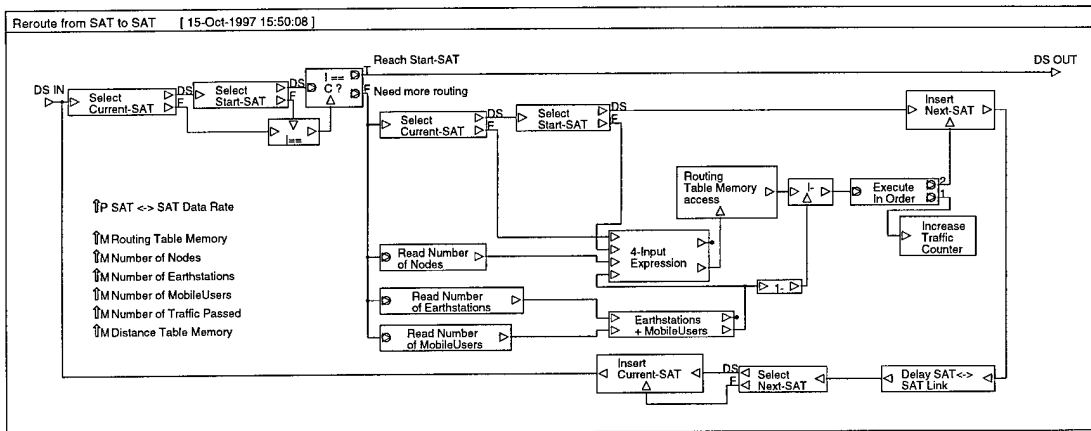

Figure 31 Reroute from SAT to SAT

detailed block diagram of *Reroute from SAT to SAT* block. After the Start-SAT receives the call setup success signal, it sends the signal to the source user and finally, the call setup request is established. In Figure 32, the final delay time is calculated and the result is stored to delay field in the call setup request data structure.

A.2 Gateway Approach

Figure 33 shows the top level block diagram of the *Gateway Approach*. In this approach, one more parameter and one more memory variable are used than the *Satellite Approach*. The

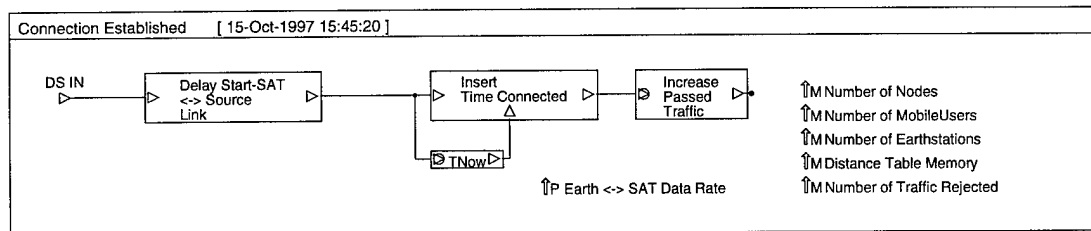

Figure 32 Connection Established

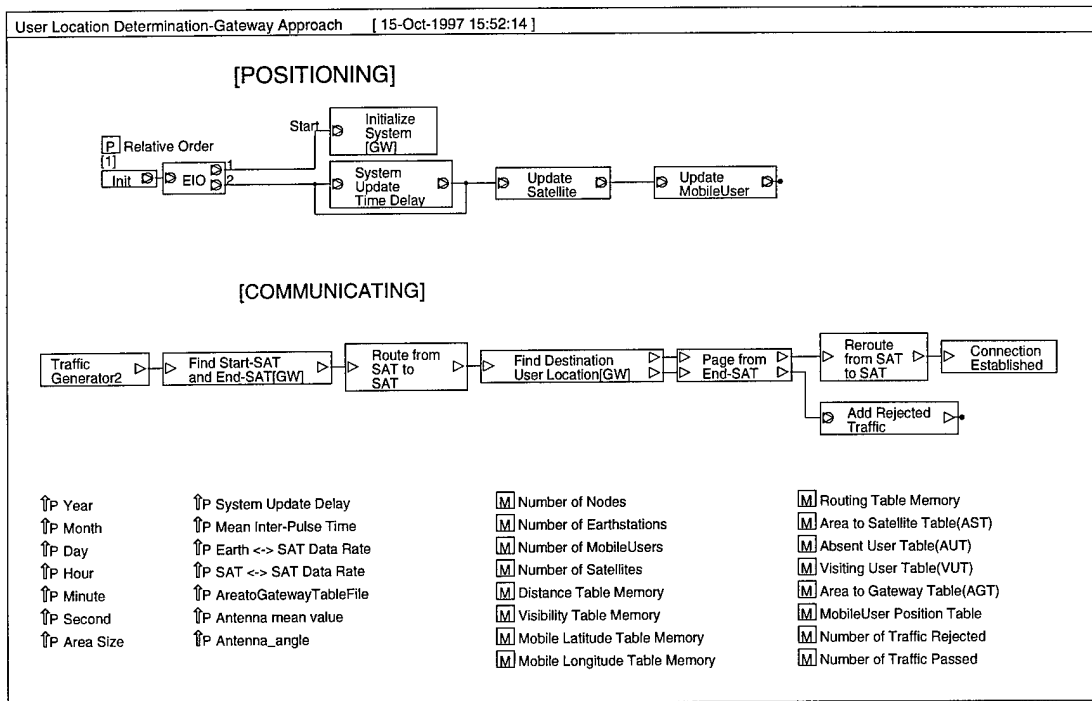

Figure 33 User Location Determination-Gateway Approach

parameter *AreatoGateway Table File* is a mapping file which maps each area to its Home Gateway. Using this external mapping file, the simulation generates a memory variable *Area to Satellite Table(AGT)*.

The other parameters and memory variables used in the *Gateway Approach* are exactly the same as those of the *Satellite Approach*. Each block function in the *Gateway Approach* is same as in the *Satellite Approach* except 4 blocks (*InitializeSystem[GW]* block, *Find Start-SAT and End-SAT[GW]* block, *Find Destination User Location[GW]* block, and *Delay SAT→GW* block). In this section, only these four block functions are covered.

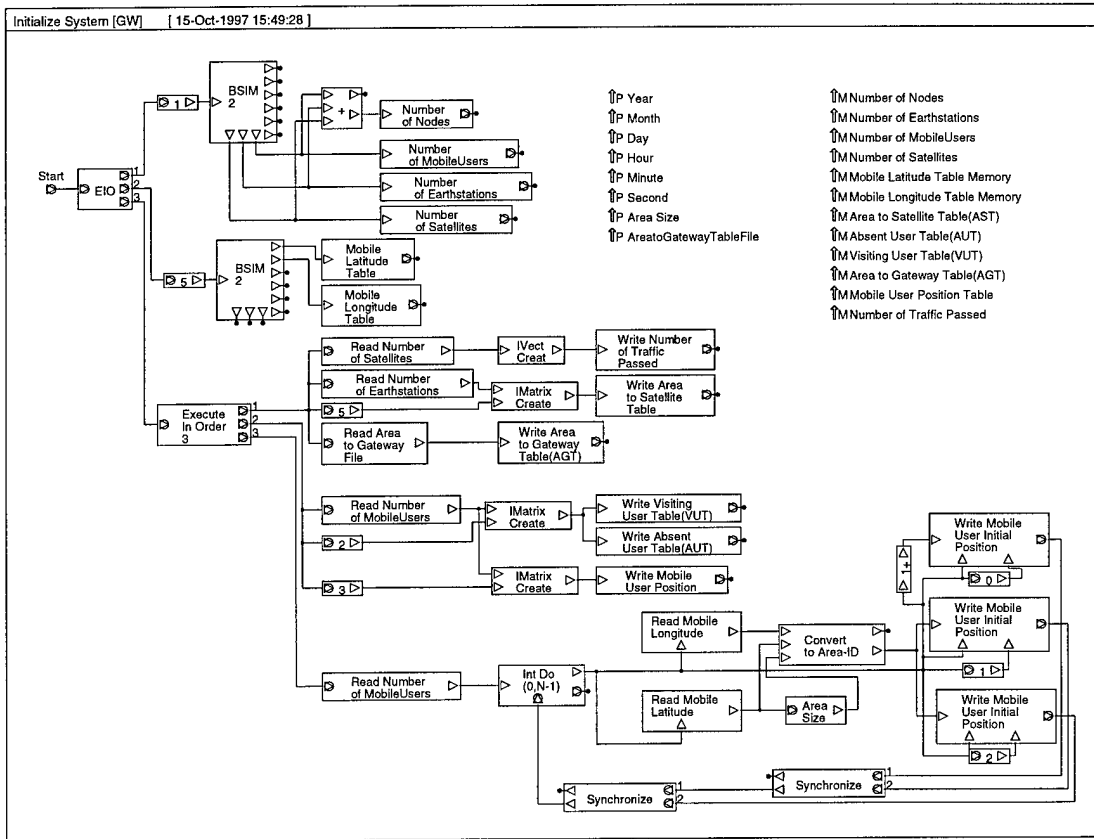

Figure 34 Initialize System[GW]

Figure 34 shows the detailed block diagram of *Initialize System[GW]*. In this block, generating memory variable *Area to Gateway Table(AGT)* is added to *Initialize System* block (Figure 14). Using this memory variable, all the area code can recognize the position of their Home Gateway.

Figure 35 shows the detailed block diagram of *Find Start-SAT and End-SAT[GW]*. First the call setup request signal searches the nearest satellite from source user like in the *Satellite Approach*. However, the End-SAT is selected among the nearest satellites from destination

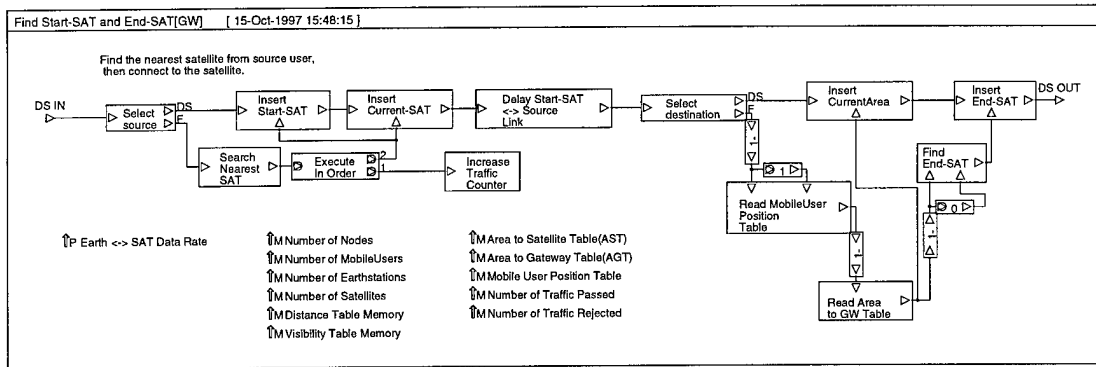

Figure 35 Find Start-SAT and End-SAT[GW]

user's Home Gateway instead of his or her Home Area. This implies that the call setup request signal is not routed to the destination user's LHS, but routed to his or her Home Gateway.

Once the call setup request signal decide the End-SAT, it is routed to the End-SAT and tries to communicate with the gateway located under the End-SAT. Figure 36 shows the detailed block diagram of *Find Destination User Location[GW]*. Before the call setup request

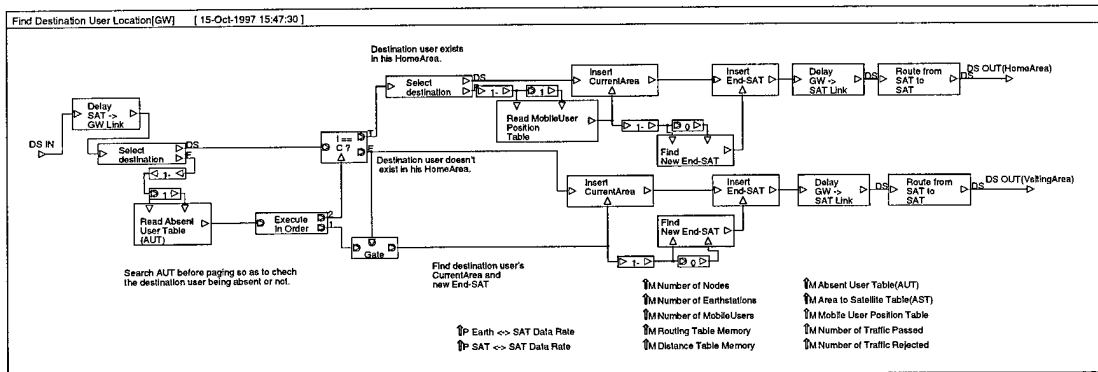

Figure 36 Find Destination User Location[GW]

arrives at destination user's Home Gateway, additional delay required to communicate with gateway station is applied (Figure 37).

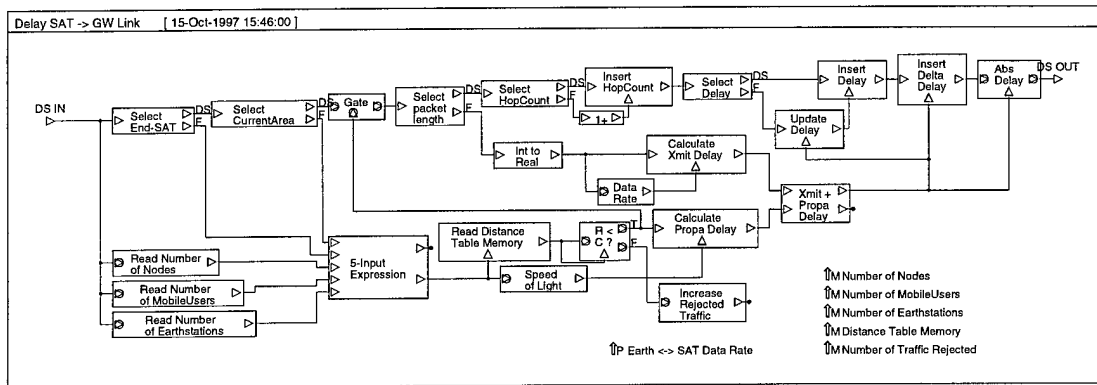

Figure 37 Delay SAT→GW Link

After the call setup request signal arrives at the gateway, it finds the destination user's current location information from the AUT and decides on a new End-SAT with the current location data. The call setup request signal is now heading to the new End-SAT and routed until it arrives at new End-SAT.

After the call setup request signal arrives at the new End-SAT that is orbiting over destination user's area, all the rest procedure is executed exactly same as Satellite Approach.

A.3 Data Structure of Call Setup Request Packet

The data structure of call setup request packet used in simulations is presented in Table 5.

Table 5 SatCom-Traffic Data Structure

Field Name	Data Type	Data Range	Default
source	INTEGER	[0, +Infinity)	
destination	INTEGER	[0, +Infinity)	
packet length	INTEGER	[0, +Infinity)	
sequence number	INTEGER	[0, +Infinity)	
Current Area	INTEGER	[0, +Infinity)	
Start-SAT	INTEGER	[0, +Infinity)	
Current-SAT	INTEGER	[0, +Infinity)	
Next-SAT	INTEGER	[0, +Infinity)	
End-SAT	INTEGER	[0, +Infinity)	
End-SAT Priority	INTEGER	[1, 5]	1
Time Created	REAL	[0, +Infinity)	
Time Connected	REAL	[0, +Infinity)	
Delta Delay	REAL	[0, +Infinity)	0.0
Delay	REAL	[0, +Infinity)	0.0
HopCount	INTEGER	[0, +Infinity)	0

Bibliography

- [AkH95] I. F. Akyildiz and J. S. M. Ho, "Dynamic mobile user location update for wireless PCS networks," *Wireless Networks* 1 (1995) 187-196.
- [BaK93] A. Bar-Noy and I. Kessler, "Tracking mobile users in wireless networks," *Proc. IEEE INFOCOM '93* (1993), pp. 1232-1239.
- [BaK94] A. Bar-Noy and I. Kessler, "Mobil Users: To update or not to update?" *Proc. IEEE INFOCOM '94* (1994), pp.570-576.
- [ChK95] H. Chang, B. W. Kim, C. G. Lee, Y. Choi, S. L. Min, H. S. Yang, and C. S. Kim, "Topological design and routing for low-earth orbit satellite networks," in *Proc. IEEE GLOBALCOM '95*, Singapore, pp.529-535, Nov 1995.
- [CoR97] G. Comparetto and R. Ramirez, "Trends in mobile satellite technology," *IEEE Computer*, Feb 1997, pp. 44-52.
- [EIA91] EIA/TIA, "Cellular radio-telecommunications intersystem operations," Technical Report IS-41 Revision B, EIA/TIA, 1991.
- [FCC91] Federal Communications Commission. "Comments of the Hughes Aircraft Company" In the Matter of Application of Motorola Satellite Communication Inc., For a Low Earth Orbit Based Mobile Satellite Communications System. File Nos. 9-DSS-P-91(87) Ccs-91-010,3 June 1991.
- [Gav97] B. Gavish, "Loe earth orbit satellite based communication systems – Research opportunities," *European Journal of Operational Research*, vol. 99, 1997, pp. 166-179.
- [Hub97] Y. C. Hubbel, "A Comparison of the IRIDIUM and AMPS Systems," *IEEE Network*, vol. 11, no. 2, March/April 1997, pp. 52-59.
- [Log95] T. Logsdon, "Mobile Communication Satellites," *McGraw-Hill, Inc.*, 1995, pp.187-188.
- [Wha97] S. H. Whang, "The start of Satellite Business Competition," The Chosun Daily News, 9 February 1992.
- [WuM94] W. Wu, E. Miller, W. Pritchard, and R. Pickholtz, "Mobile satellite communications," *Proc. IEEE*, vol 82, Sep 1994, pp. 1431-1446.

Vita

Major Jaehee Lee was born on 28 February 1964 in Masan, Republic of Korea. He graduated from Kyung Sung high school in Seoul, in 1982 and attended Korea Military Academy, from which he received a Bachelor of Science degree in 1986 and also received his Republic of Korea Army commission at the same time. His first assignment was to the Anti-air Artillery Battery, Artillery Regiment, 12th Division in Wontong, Kangwon-Do, where he served as a platoon leader of 3rd platoon. His next assignment was to the 55th Security Battalion, President Security Guard, Blue House in Seoul, where he served as Air Surveillance Officer. After finishing Officers Advanced Course in Taegu, he assigned to company commander of 505th Anti-Air Battalion, Tiger Division in Hyunri, Kyungi-Do.

Permanent address: Kyunggi-Do Sungnam-Si Sujung-Gu Singheong2-Dong 2463-1
Hansin APT #3-1103,
Republic of Korea

REPORT DOCUMENTATION PAGE			Form Approved OMB No. 0704-0188	
Public reporting burden for this collection of information is estimated to average 1 hour per response, including the time for reviewing instructions, searching existing data sources, gathering and maintaining the data needed, and completing and reviewing the collection of information. Send comments regarding this burden estimate or any other aspect of this collection of information, including suggestions for reducing this burden, to Washington Headquarters Services, Directorate for Information Operations and Reports, 1215 Jefferson Davis Highway, Suite 1204, Arlington, VA 22202-4302, and to the Office of Management and Budget, Paperwork Reduction Project (0704-0188), Washington, DC 20503.				
1. AGENCY USE ONLY (Leave blank)	2. REPORT DATE December 1997	3. REPORT TYPE AND DATES COVERED Master's Thesis		
4. TITLE AND SUBTITLE USER LOCATION DETERMINATION STRATEGY IN A LOW EARTH ORBIT SATELLITE NETWORK			5. FUNDING NUMBERS	
6. AUTHOR(S) Jaehee Lee, Major, ROK Army				
7. PERFORMING ORGANIZATION NAME(S) AND ADDRESS(ES) Air Force Institute of Technology 2750 P Street WPAFB, OH 45433-6583			8. PERFORMING ORGANIZATION REPORT NUMBER AFIT/GCS/ENG/97D-06	
9. SPONSORING/MONITORING AGENCY NAME(S) AND ADDRESS(ES)			10. SPONSORING/MONITORING AGENCY REPORT NUMBER	
11. SUPPLEMENTARY NOTES				
12a. DISTRIBUTION AVAILABILITY STATEMENT Approved for public release; distribution unlimited			12b. DISTRIBUTION CODE	
13. ABSTRACT (Maximum 200 words) <p>Recently, many Low Earth Orbit (LEO) satellite systems have been proposed for the purpose of global communication and one of those systems is planned to start the commercial service in 1998. These LEO satellite systems are providing most of current communication services (voice, fax, data, paging, and even real time video service) without any limitation on place and time. However, little is published about their detail system methodology on user tracking and managing schemes. This thesis presents two user location tracking algorithms in a LEO environment. One (Gateway Approach) is the most likely approach under present system proposals, while the other (Satellite Approach) requires more risk in implementing the proposed scheme. These two approaches are compared via computer simulation in an Iridium-like satellite network system environment. Comparative measures of call setup delay and number of hops needed to establish initial call request are examined, and minimum requirements for the Satellite Approach are discussed. It is concluded that the Satellite Approach performs better than the Gateway Approach when the memory space and computational ability of each satellite can satisfy the minimum conditions discussed in this paper. Also, the Satellite Approach experienced well balanced message distribution than the Gateway Approach. Moreover, as far as system survivability and service continuity, the Satellite Approach showed more advantageous factors than the Gateway Approach.</p>				
14. SUBJECT TERMS LEO Satellite Network, User Location Management Algorithm, Satellite Communication, Iridium Satellite Network System			15. NUMBER OF PAGES 77	
			16. PRICE CODE	
17. SECURITY CLASSIFICATION OF REPORT Unclassified	18. SECURITY CLASSIFICATION OF THIS PAGE Unclassified	19. SECURITY CLASSIFICATION OF ABSTRACT Unclassified	20. LIMITATION OF ABSTRACT UL	

GENERAL INSTRUCTIONS FOR COMPLETING SF 298

The Report Documentation Page (RDP) is used in announcing and cataloging reports. It is important that this information be consistent with the rest of the report, particularly the cover and title page. Instructions for filling in each block of the form follow. It is important to *stay within the lines* to meet *optical scanning requirements*.

Block 1. Agency Use Only (*Leave blank*).

Block 2. Report Date. Full publication date including day, month, and year, if available (e.g. 1 Jan 88). Must cite at least the year.

Block 3. Type of Report and Dates Covered. State whether report is interim, final, etc. If applicable, enter inclusive report dates (e.g. 10 Jun 87 - 30 Jun 88).

Block 4. Title and Subtitle. A title is taken from the part of the report that provides the most meaningful and complete information. When a report is prepared in more than one volume, repeat the primary title, add volume number, and include subtitle for the specific volume. On classified documents enter the title classification in parentheses.

Block 5. Funding Numbers. To include contract and grant numbers; may include program element number(s), project number(s), task number(s), and work unit number(s). Use the following labels:

C - Contract	PR - Project
G - Grant	TA - Task
PE - Program Element	WU - Work Unit Accession No.

Block 6. Author(s). Name(s) of person(s) responsible for writing the report, performing the research, or credited with the content of the report. If editor or compiler, this should follow the name(s).

Block 7. Performing Organization Name(s) and Address(es). Self-explanatory.

Block 8. Performing Organization Report Number. Enter the unique alphanumeric report number(s) assigned by the organization performing the report.

Block 9. Sponsoring/Monitoring Agency Name(s) and Address(es). Self-explanatory.

Block 10. Sponsoring/Monitoring Agency Report Number. (*If known*)

Block 11. Supplementary Notes. Enter information not included elsewhere such as: Prepared in cooperation with....; Trans. of....; To be published in.... When a report is revised, include a statement whether the new report supersedes or supplements the older report.

Block 12a. Distribution/Availability Statement.

Denotes public availability or limitations. Cite any availability to the public. Enter additional limitations or special markings in all capitals (e.g. NOFORN, REL, ITAR).

DOD - See DoDD 5230.24, "Distribution Statements on Technical Documents."

DOE - See authorities.

NASA - See Handbook NHB 2200.2.

NTIS - Leave blank.

Block 12b. Distribution Code.

DOD - Leave blank.

DOE - Enter DOE distribution categories from the Standard Distribution for Unclassified Scientific and Technical Reports.

NASA - Leave blank.

NTIS - Leave blank.

Block 13. Abstract. Include a brief (*Maximum 200 words*) factual summary of the most significant information contained in the report.

Block 14. Subject Terms. Keywords or phrases identifying major subjects in the report.

Block 15. Number of Pages. Enter the total number of pages.

Block 16. Price Code. Enter appropriate price code (*NTIS only*).

Blocks 17. - 19. Security Classifications. Self-explanatory. Enter U.S. Security Classification in accordance with U.S. Security Regulations (i.e., UNCLASSIFIED). If form contains classified information, stamp classification on the top and bottom of the page.

Block 20. Limitation of Abstract. This block must be completed to assign a limitation to the abstract. Enter either UL (unlimited) or SAR (same as report). An entry in this block is necessary if the abstract is to be limited. If blank, the abstract is assumed to be unlimited.