

JPRS-JST-90-022  
27 APRIL 1990

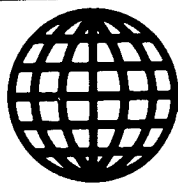

**FOREIGN  
BROADCAST  
INFORMATION  
SERVICE**

# ***JPRS Report***

**DISTRIBUTION STATEMENT A**

**Approved for public release  
Distribution Unlimited**

# **Science & Technology**

***Japan***

APPLIED ELECTROMAGNETICS IN MATERIALS

19980130 055

REPRODUCED BY  
U.S. DEPARTMENT OF COMMERCE  
NATIONAL TECHNICAL INFORMATION SERVICE  
SPRINGFIELD, VA. 22161

**DMC QUALITY INSPECTED 3**

SCIENCE & TECHNOLOGY  
JAPAN

APPLIED ELECTROMAGNETICS IN MATERIALS

43070725 Kanazawa ISEM - KANAZAWA in English 9-11 Jan 90  
pp 1-75

[Selected abstracts of papers presented at the 2nd International Symposium on Applied Electromagnetics in Materials held 9-11 Jan 90 in Kanazawa and organized by the Electrical Energy Conversion Laboratory, Faculty of Technology, Kanazawa University. The symposium theme is "High Magnetic Field Generation and Its Application to Materials and Biological Systems".]

CONTENTS

Preparation of Ba-Y-Cu-O Films by Laser Ablation (Invited) [Tatsuo Shimizu, Akiharu Morimoto].....	1
Electromagnetic Properties of Some Superconducting Ceramics and Thin Films [H. Koinuma, M. Yoshimoto, et al.].....	2
A Practical Structural Stress Evaluation System for Super Conducting Coil With Inner Ring Support [Shinzou Okada, Yoshio Iwahashi, et al.].....	3
Recent Trends in High Field Magnetism (Invited) [M. Date, A. Yamagishi].....	4
The High Magnetic Field Generators Based on the Eddy-Current Effects (Invited) [Kazuo Bessho].....	5

Numerical Simulation of Magnetic Flux Cumulation Driven by High Pressure Shock Waves in Powder [Kunihito Nagayama, Terutoshi Murakami].....	7
Bending of a Magnetically Saturated Plate With a Crack in a Uniform Magnetic Field [Yasuhide Shindo, Katsumi Horiguchi, et al.].....	9
Dynamic Behavior of a Thin Plate Under Moving Magnetic Field [T. Takagi, J. Tani, et al.].....	10
A Magnetic Levitated Actuator Using a Permanent Magnet and an Electromagnet and Its Application to Active Control of a Magnetic Levitated Body [Kosuke Nagaya, Noriyuki Arai].....	11
Focal Stimulation of the Human Brain by a Pair of Opposing Pulsed Magnetic Fields (Invited) [S. Ueno, T. Matsuda, et al.].....	12
Transcutaneous Energy Transmission Using Amorphous Magnetic Fiber for Artificial Heart System [H. Matsuki, M. Shiiki, et al.].....	13
Flaw Detection in Steel Plates by Means of Barkhausen Effect (Invited) [Y. Kagawa, T. Nakamura].....	15
Numerical Analysis of Magnetic Field in High Permeable Magnetic Circuit Taking Hysteresis B-H Curve into Account [Tatsuei Nomura].....	17
Magnetic Field Analysis by FEM Applying Preisach's Magnetization Model [C. Hamamura, M. Okabe].....	18
A Study for Approximation of Magnetic Characteristics [E. Itoda, Y. Ishihara, et al.].....	20
Shielding Effects of Permanent Magnetic Assembly for MRI [H. Sakurai, M. Aoki].....	22
Design of the Hybrid Magnet in a Magnetic Levitation System Using the Boundary Element Method [Takashi Onuki, Syunsaku Koga, et al.].....	23
3-D Analysis of a Cylinder-Type Flux Concentration Apparatus [T. Yoshimoto, K. Bessho, et al.].....	25
Non-Linear Electric Field Computation - In the Space-Charge-Limited Case - [Y. Uchikawa, T. Watanabe, et al.].....	26

Development and Application of Harmonic Balance Finite Element Method in Electromagnetic Field [J. Lu, S. Yamada, et al.].....	27
Numerical Analysis of Magnetic Field in Superconducting Magnetic Energy Storage [Y. Kanamaru, Y. Miyamoto, et al.].....	29
Dual Discretization Method for Semiconductor Device Simulator [T. Kojima, Y. Saito, et al.].....	30
An Electro-Magnetic Field Analysis of Two-Dimensional MPD Arcjet Thrusters Using Boundary Element Method [Shinichi Sawai, Hajima Igarashi, et al.].....	31

# PREPARATION OF Ba-Y-Cu-O FILMS BY LASER ABLATION (INVITED)

Tatsuo Shimizu and Akiharu Morimoto  
Department of Electronics, Faculty of Technology,  
Kanazawa University, Kanazawa 920, Japan

Results on the preparation of  $Ba_2YCu_3O_x$  superconducting films by excimer laser (ArF) ablation method carried out by our group will be reviewed. The laser ablation method is a promising method to prepare multicomponent oxide films because the deviation of the composition in the films from the target is small and a rather high pressure oxygen environment is possible.

We were able to prepare  $Ba_2YCu_3O_x$  films with  $T_{c0}=82K$  (critical temperature of zero resistivity) directly on crystalline Si. Nominal substrate temperature  $T_s$  in this case was 650 °C. To reduce  $T_s$ , we examined the effect of the laser irradiation onto the growing film surface. We found that in-situ excimer laser irradiation onto the growing film surface improves the superconducting properties and the surface morphology of the films prepared at a relatively lower  $T_s$ .

The effect of the use of  $N_2O$  gas instead of  $O_2$  gas on preparation of the film was examined in a similar technique. It was revealed that  $N_2O$  environment enhances the c-axis orientation for the film on crystalline Si, compared with  $O_2$  environment.

## ELECTROMAGNETIC PROPERTIES OF SOME SUPERCONDUCTING CERAMICS AND THIN FILMS

H.Koinuma, M.Yoshimoto, K.Takeuchi, S.Tanabe\*, and N.Soga\*

Research Laboratory of Engineering Materials

Tokyo Institute of Technology

4259 Nagatsuta, Midori-ku, Yokohama 227, Japan

\*Faculty of Engineering, Kyoto University

Yoshida-honmachi, Sakyo-ku, Kyoto 606, Japan

Recently discovered high  $T_C$  oxide superconductors exhibit electromagnetic properties highly dependent on the carrier concentration which can be controlled by the substitution of metallic element as well as by the oxygen stoichiometry. In the present study, we prepared thin films of Bi-Sr-Ca-Cu-O, Nd-Ce-Cu-O, and La-Eu-Ce-Cu-O systems to develop a new method for adjusting the oxygen stoichiometry, i.e. hole concentration, in the former system and to elucidate the type of charge carriers (p: hole or n: electron) and electronic state in the latter two systems. Thin films of these systems were prepared by using our original ac sputtering apparatus<sup>1)</sup>. Nearly single phase  $\text{Bi}_2\text{Sr}_2\text{Ca}_1\text{Cu}_2\text{O}_x$  films with  $T_C$  onset at 80K were treated with variously activated oxygens at 400°C. The exposure of the films to UV light in oxygen and  $\text{N}_2\text{O}$  atmospheres resulted in a contrastive change in  $T_C$ ; the former decreased and the latter increased  $T_C$  by as much as 20K. Oxygen plasma and ozone treatments worked similarly to the former case. These changes were reversed by annealing the films in air at 400°C. This change in  $T_C$  was found to be linearly correlated with the change in c lattice parameter. Since the c lattice parameter reflects the oxygen content in the superconductor, the result indicates that the carrier concentration in  $\text{Bi}_2\text{Sr}_2\text{Ca}_1\text{Cu}_2\text{O}_x$  films can be reversibly controlled by various oxygen treatments. Hall measurement showed p-type characteristic of the films.

Nd-Ce-Cu-O films were deposited on  $\text{SrTiO}_3$  at 600°C and annealed in Ar atmosphere at 1000°C to show the superconductivity at 15K. A new bulk superconductor was obtained by substituting Nd in  $\text{Nd}_{2-y}\text{Ce}_y\text{CuO}_{4-\delta}$  by La and Eu to show a diamagnetism (Meissner effect) at 18K and below. Hall effect and Mossbauer spectra of this compound were measured to characterize the charge carrier and valence state of Eu.

Ref.1) H.Koinuma, M.Kawasaki, S.Nagata, K.Takeuchi, and K.Fueki: Jpn. J. Appl. Phys. 27, L376 (1988)

# A Practical Structural Stress Evaluation system

for Super Conducting Coil with Inner Ring Support

Shinzou Okada, Yoshio Iwahashi and Hiroyuki Mori

Hiratsuka Research Laboratory, Sumitomo Heavy Industries, Ltd.

63-30, Yuhigaoka, Hiratsuka, Kanagawa-ken, 254, Japan

## ABSTRACT

High-field and high-energy super conducting coils sometimes could not achieve the expected performance, because of the lack of the structural strength or the mechanical quench phenomena induced by their large magnetic force.

This paper describes a structural stress evaluation method and a analysis system at the design of the inner ring supported type super conducting coils from the mechanical strength point of view. A new method for calculating the axisymmetric or 3 dimensional winding stress was developed, with the aid of a conventional structural analysis FEM code. Addition to that, magnetic force generator was made, which calculate the equivalent nodal forces for the structural model from magnetic field analysis result for the general cases, where the mesh for the structural calculation and that for the magnetic field calculation do not match.

To confirm the effectiveness of this system, we carried out the stress evaluations of a high-field test coil, and the calculated results will be discussed.

RECENT TRENDS IN HIGH FIELD MAGNETISM ( INVITED )

M. DATE AND A. YAMAGISHI<sup>#</sup>

Department of Physics, Faculty of Science,

<sup>#</sup>Research Center for Extreme Materials,

Osaka University

Toyonaka, Osaka 560

ABSTRACT: Recent trends and activities in high field magnetism mainly developed in Osaka University are reviewed. The work is classified into five categories and the corresponding main results are discussed in the following way:

(1) Magnetic Phase Transitions

Field-induced phase transitions such as the metal-insulator transitions, field-induced ferromagnetism and break down of electronic band structures are shown.

(2) Magnetoresistance under High Magnetic Field

Novel properties of high-T<sub>c</sub> superconductivity are mainly discussed.

(3) Magneto-Optics

Nonlinear Zeeman effect and field-induced transparency are shown.

(4) Diamagnetic Orientation of Organic Molecules

The discussion is concentrated to the field effect on biological materials.

(5) Magnetic Resonance

High field ESR applied to exotic phase transitions is introduced.

THE HIGH MAGNETIC FIELD GENERATORS  
 BASED ON THE EDDY-CURRENT EFFECTS (INVITED)

Kazuo BESSHO  
 Electrical Energy Conversion Lab.  
 Kanazawa University  
 Kanazawa, Japan

ABSTRACT; This paper describes the performances and features of various kinds of new high magnetic field generators based on the eddy-current effects. The principle of these generators is different from previous published or tested.

In generally, DC high magnetic field generator have been used such as superconductive magnet and various kinds of pulse magnets which are made of normal materials. These generators, however, are expensive and not so easy to handle. For example, the former magnet needs a refrigerator system and the latter usually use a considerably large capacitor bank.

The new generators proposed by the authors uses a relatively small-scale electric source which is convenient for various engineering demands. The feature of the high-speed rotating type DC high magnetic field generator as shown in Fig.1, is that an energy for generating a magnetic field is the kinetic energy of disks. The asymmetrical eddy-current on the disk induced by the motional magnetomotive force earn the flux concentration and the DC high magnetic field is generated on the hole surrounded with four disk. The testing apparatus is based on the above principle. After the disks are driven to the high speed by induction motors, the motors are disconnected from disk and a excitation current is applied to an electromagnet.

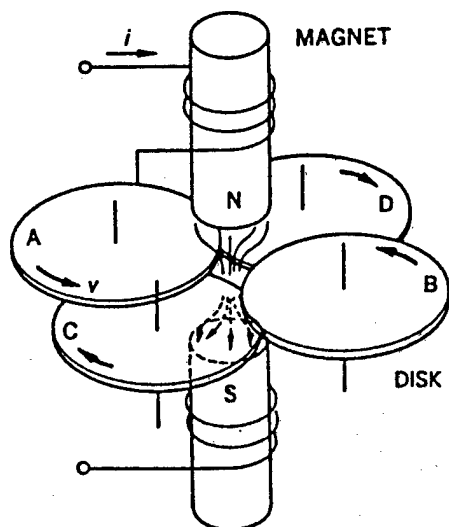

Fig.1 High-speed rotating type generator

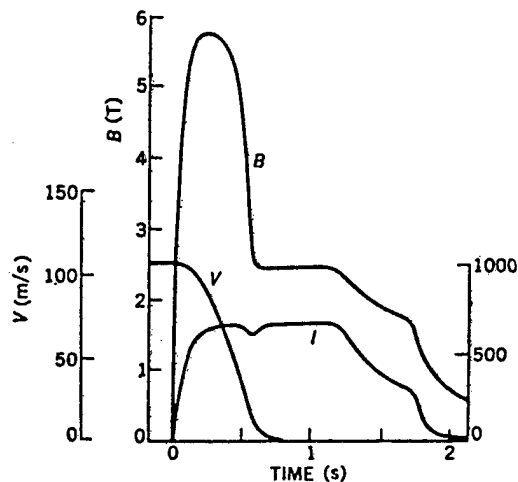

Fig.2 Waveforms of flux density B, velocity of disk V and exciting concentration.

The results of this experiment are shown in Fig.2, when the disks rotate at 4000rpm ( $V=107\text{m/s}$  at the edge of disk) and the excitation current of 660A is applied, the magnetic flux density in the holes to 5.8T and then decreases to 2.4T as the disks stop within 0.6s by the braking force.

On the other hand, there are very few paper on the AC high magnetic field generator to be reported. Recently, to investigate the effects of AC high magnetic field on the biology and especially to develop the more strong linear-induction type electromagnetic pump, a new technology for making AC high magnetic field is anxious to be requested.

We have already proposed the multilayer coil by means of the shield effect of the magnetic flux due to the eddy-current in the static conductive plate, and obtained ac high magnetic field about 16T at 60 Hz. The phenomenon by the eddy-current is similar to the above mentioned one by the asymmetrical eddy-current.

Fig.3 shows a new multilayer coil with core. In order to improve the characteristic, we cut off a portion around the hole where is no eddy-current and put the core in. The core is linked with the exciting coil and the cylinder for exciting admittance turn to lower and the exciting current will be reduced considerably. For this effects, the input current is decreased.

Fig.4 shows the laminated coil without core. This device consist of the spiral-shape coil for exciting current and the piled conductive plates with a slit designed radial direction for concentrating eddy-current around the hole. By using this simple structure, we can make the conductive plate of copper-alloy plate which is stout in high temperature. The characteristics of the new apparatus are describes. It can be applied to an AC high magnetic field generator and an linear induction type electromagnetic pump. We think it has the possibility of application to new electric machines.

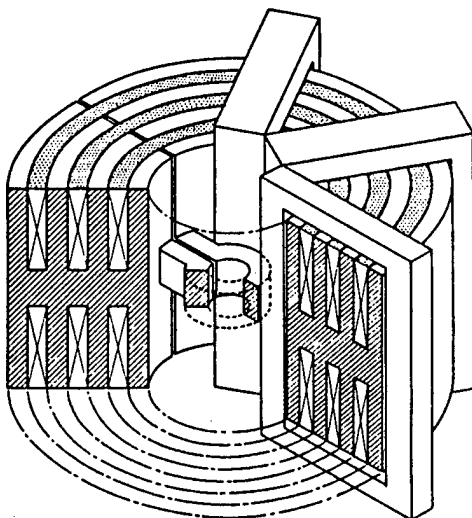

Fig.3 Multilayer coil with core

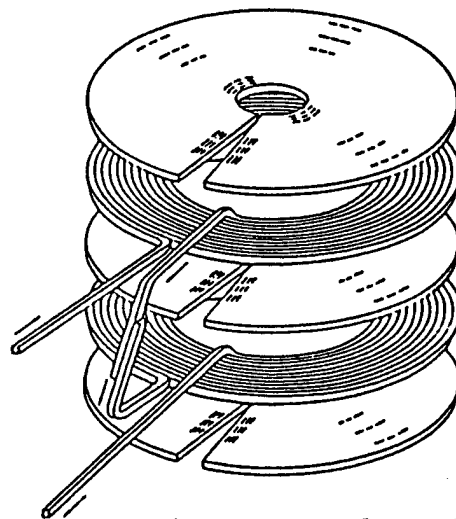

Fig.4 Laminated coil

# Numerical Simulation of Magnetic Flux Cumulation Driven by High-Pressure Shock Waves in Powder

Kunihito Nagayama and Terutoshi Murakami

Department of Applied Science,

Faculty of Engineering,

Kyushu University,

Hakozaki, Higashiku, Fukuoka 812, Japan

## Abstract :

Recently, a new method of magnetic flux cumulation has been invented and tested by one of the authors, and independently by the group of Prof. Bichenkov at Novosibirsk. The key idea is the use of high-pressure shock wave front in powders with a drastic jump in electrical conductivity at the wave front. Simple analysis have revealed that magnetic flux ahead of the shock front is driven by the shock wave in proportion to the ratio of particle velocity to wave velocity. In this method, the shock wave energy is transformed into the electromagnetic energy. Therefore, shock wave in powder may attenuate as the magnetic flux density increases very high.

Feasibility of the present method has been discussed theoretically in this report. The numerical simulation of the interaction process of shock wave front with magnetic flux has been performed to know how and where the shock attenuates. Gruneisen type equation of state was assumed for the high-pressure states of shock-compressed powder. Material

constants have chosen to represent aluminum powder of very low density of about  $0.3 \text{ g/cm}^3$ .

Electrical conductivity in the region behind the shock front was assumed to be infinite, then each magnetic flux moves with the particle velocity. Under this assumption, magnetic field has no contribution to the Hugoniot compression curve for powder.

Interaction of magnetic flux with the shock front were described by the magnetohydrodynamic (MHD) flow equations, coupled with the magnetic flux compression equation, which holds at the shock front, derived from the magnetic induction equation across the front. Cylindrically converging shock wave in powder is assumed to be generated by the cylindrical shock tube initial condition. To resolve the shock front position converging to very small radius, logarithmic coordinate was used. Conventional finite difference method has been used to solve the system of equations.

A series of numerical calculations have been performed by varying the porosity of powder, initial field strength, etc. Numerical results in the case of very low initial flux density have been well explained by the CCW theory, whereas those for appropriate initial flux density reproduce the very drastic shock wave decay in powder, when the value of magnetic field strength increases around or over 10 MG. It can be concluded that the present method serves a promising alternative for the conventional liner implosion method to attain pulsed ultrahigh fields.

# Bending of a Magnetically Saturated Plate with a Crack in a Uniform Magnetic Field

Yasuhide Shindo

Department of Mechanical Engineering II,  
Faculty of Engineering, Tohoku University  
Sendai 980, Japan

Katsumi Horiguchi

Department of Mechanical Engineering,  
Tokyo Metropolitan Technical College  
Tokyo 140, Japan

A. A. F. van de Ven

Department of Mathematics and Computing Science,  
Eindhoven University of Technology  
Eindhoven, The Netherlands

The Study of magnetoelasticity has attracted the attention of scientists because of its increasing applications to engineering problems. Interest in the theory of cracks has also grown considerably due to various technical applications. The stress and strain state in a magnetizable elastic body is caused not only by mechanical loads but also by magnetic loads. When a cracked magnetizable elastic plate is placed in an external magnetic field, the existence of the magnetic field may produce higher singular moments near the crack tip.

A ferromagnetic medium is soft magnetic only within a limited range of the magnetization curve and there is a gap between the soft magnetic range and the saturation point. In this investigation, the linear magneto-elastic analysis of a magnetically saturated flat plate with a through crack under a uniform magnetic field is discussed. The cracked plate with simply-supported ends is loaded by bending moments. Classical plate bending theory for magneto-elastic interactions in magnetically saturated bodies is applied and the magnetic field is perpendicular to the plate surfaces. Fourier transforms are used to reduce the magneto-elastic problem to an integro-differential equation for the deflection. Iteration method is then employed to solve the integro-differential equation. The solution of the crack problem is expressed in terms of a Fredholm integral equation of the second kind. The moment intensity factor for bending stress loading is computed and the influence of the magnetic field on the normalized values is displayed graphically. Results for the saturation model are compared with those for soft ferromagnetic bodies.

# Dynamic Behavior of a Thin Plate under Moving Magnetic Field

T. Takagi, J. Tani and S. Matsuda

Institute of Fluid Science  
Tohoku University, Japan

To put a magnetically levitated vehicle to practical use, it is of technical importance to clarify the dynamic behavior of electrically conducting structures under moving magnetic field. Eddy currents are induced in the conductor under moving magnetic field. The eddy current causes electromagnetic forces in the conductor due to an interaction with magnetic field. The significant dynamic deformation of the structure may often result from this Lorentz force.

In the present paper, the dynamic behavior of thin electrically conducting plates under moving magnetic field is analyzed numerically by means of the finite element method in conjunction with the modal analysis. The assumption of the small bending plate theory and two-dimensional currents are used for the motion of the thin plate and the eddy current in the plate, respectively. Furthermore it is assumed that the moving magnetic field is produced by a coil which moves parallel to the plate. The eddy current also is examined by the finite element method. When the diameter of the coil is almost equal to the width of the plate, the eddy current density becomes large along both the edges of the plate and then the Lorentz force is large along the same part. The dynamic behavior of the plate depends on the strength of the magnetic field produced by the coil and the speed of the moving coil. There is found to be the critical speed of the moving coil at which the deflection of the plate enlarges significantly. The critical speed depends on the size and boundary condition of the plate.

A MAGNETIC LEVITATED ACTUATOR USING  
A PERMANENT MAGNET AND AN ELECTRO-  
MAGNET AND ITS APPLICATION TO ACTIVE  
CONTROL OF A MAGNETIC LEVITATED BODY

Kosuke Nagaya

Department of Mechanical System Engineering  
Faculty of Engineering, Gunma University  
Kiryu, Gunma, 376, JAPAN

Noriyuki Arai

Shimazu Production CO-LTD  
Chuouku, Kyoto 604, JAPAN

**ABSTRACT:** Since the spring constant generated by the electromagnetic force in a magnetic levitated system is small, the vibration control is required, and an electromagnetic actuator has been utilized for controlling vibrations. In this system the electromagnetic force is used to support a gravity force of a levitated body and to control vibrations. Hence large and strong magnets are required for supporting a large gravity force.

This paper proposes an actuator in the magnetic levitation system using a permanent magnet and an electromagnet. In this actuator the gravity force of the levitated body is supported by a strong permanent magnet in which two same poles are faced with each other. The vibration due to external disturbances is controlled with use of the electromagnet by changing magnetic fluxes of one of the permanent magnet. The analytical expressions for obtaining the levitation force, spring constant and the control force versus the electric current in the electromagnet were derived.

Numerical simulations under the control using the optimal regulator for the magnetic levitated body were carried out. To verify the present analysis, experimental results were also obtained.

FOCAL STIMULATION OF THE HUMAN BRAIN BY A PAIR OF  
OPPOSING PULSED MAGNETIC FIELDS (INVITED)

S.Ueno\*, T.Matsuda\* and M.Fujiki\*\*

\* Department of Electronics,  
Kyushu University, Fukuoka 812, Japan

\*\*Department of Neurosurgery,  
Medical College of Oita, 879-56 Japan

A method of localized stimulation of the human brain is proposed. The basic idea is to concentrate induced eddy currents locally in the vicinity of a target by a pair of opposing pulsed magnetic fields. A pair of coils are positioned outside the head so that time-varying magnetic fields pass through the head in the opposite directions around a target. The eddy currents induced at the target are expected to flow together, which results in an increased current flow at the target. The current density at the target makes a peak which is higher by 2-3 times than current densities at nontarget regions. Based upon the computer simulation, a figure eight coil is designed, and the magnetic brain stimulation is carried out using ourselves as volunteers. The results show that the selective stimulation of the brain is realized within a 5mm resolution. The functional mapping of the human motor cortex related to the hand, arm and foot areas is obtained. It is also obtained that an optimum direction of stimulating currents for neural excitation exists in each functional area in the cortex. Stimulating currents which flow in the direction from the temporal to the frontal region at the right hemisphere in the brain, excite neural population related to the hand area, whereas, stimulating currents which flow in the direction from the frontal to the occipital region, excite neural population related to the foot area. The functional localization of the human motor cortex related to the thenar muscle with the muscle totally relaxed and contracted is obtained.

TRANSCUTANEOUS ENERGY TRANSMISSION USING AMORPHOUS MAGNETIC FIBER  
FOR ARTIFICIAL HEART SYSTEM

H. Matsuki, M. Shiiki

Dept. of Electrical Eng., Tohoku Univ., Sendai Aoba-ku, 980 Japan

K. Nadehara, T. Yamamoto

R & D Center, UNITIKA LTD., Uji, 610 Japan

and

K. Murakami

Hachinohe Inst. of Technology, Hachinohe, 031 Japan

**ABSTRACT** For an implanted artificial heart system many papers report electrically actuated ones. It is a serious problem for such a system to obtain a thin transformer transmitting electrical energy from outside a body.

This paper reports a new transformer with cloth structure utilizing amorphous magnetic fibers. The amorphous magnetic fiber acts not only as a flux concentrator but as a shielding material against a body.

The problem is how to minimize magnetic cores. The analysis shows that a magnetic core having a long and narrow shape is advantageous for a core implanted inside a body.

The transformer has a woven structure: bundles of amorphous fibers of 50  $\mu\text{m}$  in diameter are arranged radially and a copper wire is woven in spiral form.

The transcutaneous transformer made as a trial can transmit electrical energy of 20 W continuously. The temperature rise based on the iron loss of the amorphous fiber is negligibly small up to the frequency range of 100 kHz. As a sectional area of tissues to be exposed to magnetic field will be less than  $0.01 \text{ m}^2$  the influence of a time varying magnetic field upon a body will be not serious problem in this case.

The transformer is characterized by the flexibility. As shown in Fig. 1 the load characteristic is not influenced very much even if the transformer is bent. It will become possible for such a transformer to be set along a body surface of a patient.

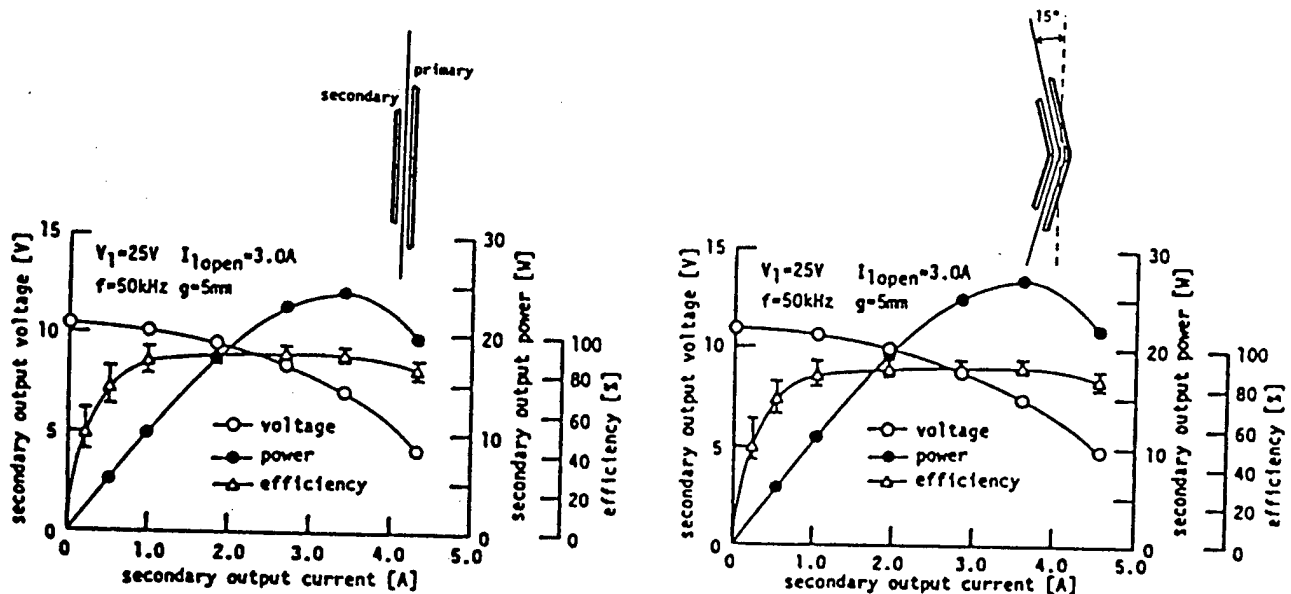

Fig. 1. Load characteristics of the transformer.

Flaw Detection in Steel Plates by means of  
Barkhausen Effect (invited)

Y.Kagawa and T.Nakamura

(Dept. of Electronics and Information Engng., Toyama Univ., Japan)

Abstract

A new technique is proposed for detecting flaw in ferromagnetic materials making use of Barkhausen effect. Barkhausen effect is the noise generation in ferromagnetic materials due to the magnetization under the application of magnetic fields. Examination is made for the event rate of the Barkhausen noise in steel plates under quasi-static magnetization process. It is found that the event rate depends on the course of the magnetization or the route and direction in the B-H hysteresis loop and the rate changes in the presence of the flaw.

Fig.1 shows a sensor assembly made of electromagnetic magnetizer and detector. The sensor assembly is placed over a steel plate to be examined. The proper current is applied to excite the magnetizer which magnetizes the plate. The magnetization emits the Barkhausen noise whose rate of events is picked up by the detector coil. The number of the events is counted and recorded. Fig.2 shows an example of the exciting current and the corresponding routes in the B-H loop. Other routes can be achieved by changing the direction of the current. Fig.3 shows the test sample (steel plate, SS41) with flaw artificially provided by a milling machine. Fig.4 shows an example of the event rate of the Barkhausen noise measured for the exciting current as indicated in the figure. The event rate is measured when the sensor assembly moves parallel to the flaw over the plate surface, which is shown in Fig.5 (a). Fig.5 (b) is the case when the movement is made across the flaw. Fig.6 shows the event rate measured when the sensor assembly is rotated about the center of the flaw.

For all cases, the sensing is made from the rear surface where no flaw is visible. In all cases, the event rate is measured for the route of the descending exciting current. Demagnetization is made by using 60Hz current prior to each measurement, and the measurement is repeated four times at each position.

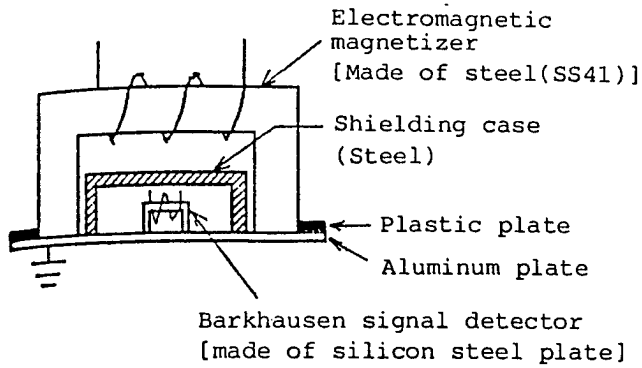

Fig.1 Electromagnetic magnetizer and signal detector assembly.

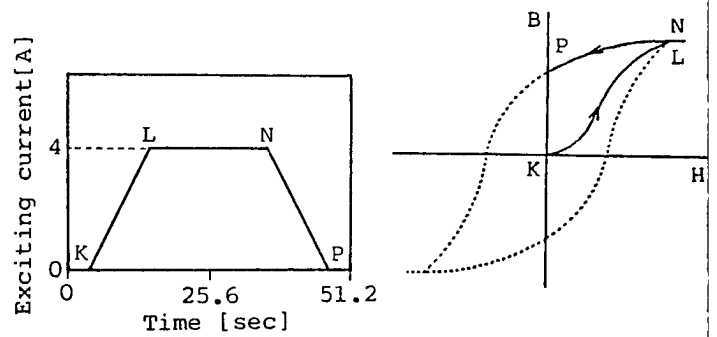

Fig.2 Exciting current to the magnetizer and the corresponding magnetization curve.

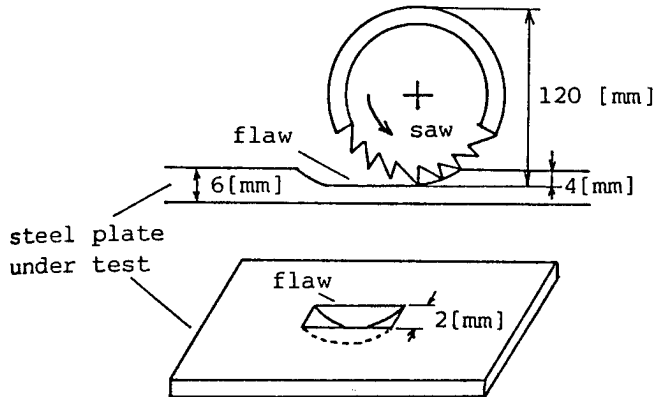

Fig.3 Flaw artificially provided on the plate.

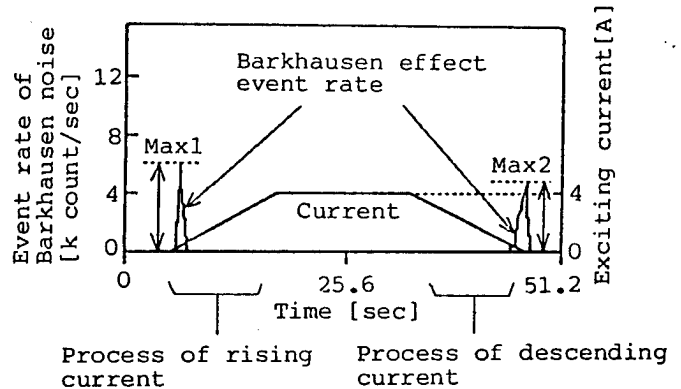

Fig.4 Change of the exciting current and Barkhausen effect due to magnetization.

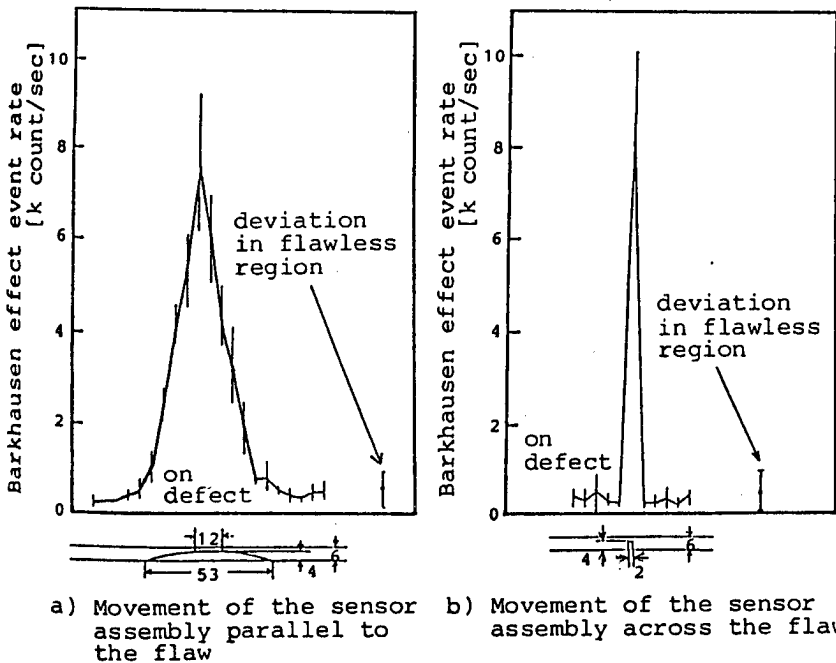

Fig.5 Change of event rate of Barkhausen noise. (current descending process)

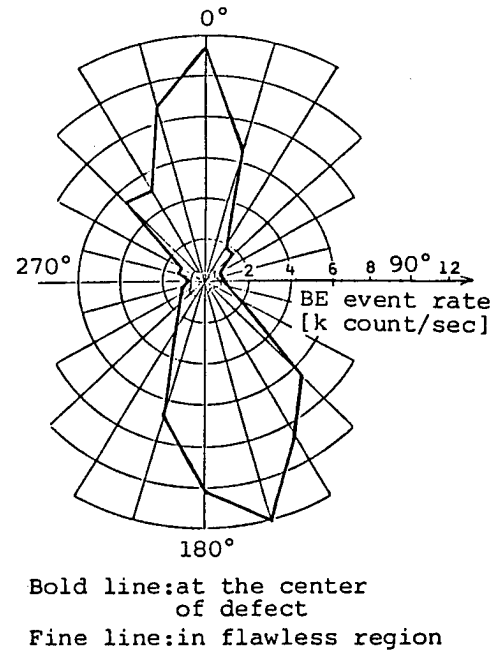

Fig.6 Event rate of Barkhausen noise. (Sensor assembly rotates at the center of the flaw, current descending process)

# Numerical Analysis of Magnetic Field in High Permeable Magnetic Circuit

## Taking Hysteresis B-H Curve into Account

Tatsuei Nomura

Osaka Electro-Communication University

Abstract In high permeable magnetic circuit such as power transformers, the magnetic hysteresis of material affects the flux distribution. In the case of a distribution transformer with wound-type iron core, the difference of phase angle between the innermost and outermost circuits is considerably large as well as the wave form.

When using a saturated B-H curve without hysteresis, we get an answer which seems to be reasonable, but the difference of the phase angles mentioned above is much smaller than the measured. Because the effect of eddy current in iron core is equal to the difference between the AC- and DC-hysteresis curves, the author has reported an analysis taking the eddy-current in iron core into account. The angle difference was improved, but it was about 50 % of the measured value[1]. Doubling the eddy current effect, we may get a good result. Saito et al proposed this improvement using "hysteresis coefficient" which magnifies the eddy current effect[2]. The author, however, will present a valid method: The author take exactly the DC-hysteresis effect into consideration. The DC-hysteresis curve of material is represented using Preisach theory. A Preisach method using exponential functions proposed by Coulson et al [3] is applied to the analysis. The author shows that the method is applicable and gives improved results.

### References

- [1] T. Nomura: "An Analysis of Magnetic Circuit with Wound-Type Iron Core Considering Eddy-Current in Iron Core", Research Meeting on Magnetic Materials of IEE of Japan, Paper No. MAG-75-23, (1975)
- [2] Y. Saito, H. Saotome, S. Hayano and T. Yamamura: "Modeling of Hysteric and Anisotropic Magnetic Field Problems", IEEE Trans. on Magnetics, Vol. MAG-19 pp 2510-2513 (1983)
- [3] M.A. Coulson et al: "Representation of magnetic characteristic, including hysteresis, using Preisach's theory", Proc. IEE, Vol. 124, No. 10, pp 895-898 (1977)

# Magnetic Field Analysis by FEM Applying Preisach's Magnetization Model

C. Hamamura and M. Okabe

Materials & Electronic Devices Lab., MITSUBISHI ELECTRIC CORP.  
Amagasaki, 661 Japan

## Introduction

The conventional design of electromagnetic devices which make use of residual magnetic phenomena have almost depended on many years' experimental experience. However, in recent years numerical representation method of magnetization have been studied by a number of reseachers.

In this paper, a procedure for constructing a magnetization model on a Preisach diagram and a method for the magnetic field analysis applying this model are presented.

## Modeling of Magnetization Characteristic

Preisach proposed <sup>11)</sup> that a ferromagnetic material is considered a set of dipoles, each of them is characterized by rectangular hysteresis loop having magnetization state of  $\pm 1$  and various coercivities ( $H_i, H_j$ ). Then magnetization in the materials are defined as follows.

$$M = \int \int P(H_i, H_j) D(H_i, H_j) dH_i dH_j \quad (1)$$

where  $P(H_i, H_j)$  is a function of distribution density  
 $D(H_i, H_j)$  is a function of magnetization state.

This model is pointed out to have a instability area taking negative value of distribution function <sup>12)</sup>. Then we make approximate treatment to calculated M-H loops without modification of the area.

## Method of Magnetic Field Analysis

Fig.1 shows a concept of analysis with the magnetization model. The distribution function is calculated from a set of major loops which are got automatically by a personal-computer. Two-dimensional magnetic fields are

analyzed using the finite element method that includes a Maxwell's equation for magnetic analysis and the restoration of magnetization with the distribution function.

In the process of calculation, the hysteresis characteristics of ferromagnetic materials are retained for each element.

Application for electromagnetic devices

For example, this method can be applied to the calculation of reproduction-output characteristics in magnetic recording which has large magnetic anisotropy.

Conclusion

The Preisach distribution function models are convenient for representing the complicated magnetization process except time-dependent phenomena. We believe it can be applied to the magnetic field analysis, that must include the consideration of magnetization process, with practical accuracy .

Reference

- [1] F.Preisach, Zeitschrift für Physik, vol.94, 277 (1935)
- [2] I. D. Mayergoyz, IEEE Trans. on Mag., vol.24, 212 (1988)

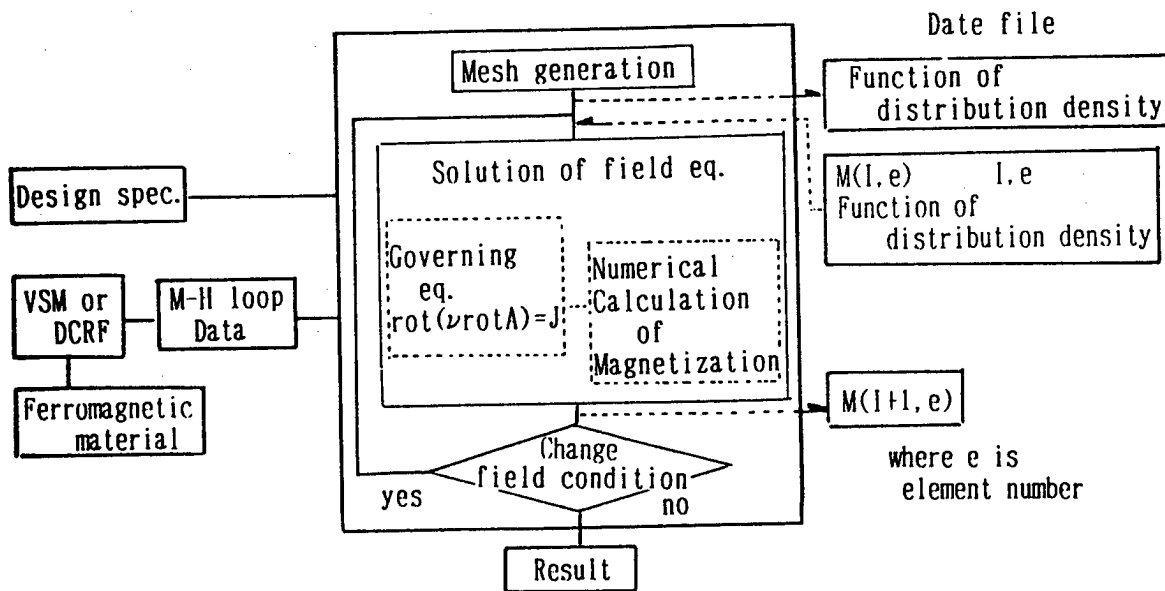

Fig.1 Concept of Analysis with Magnetization Model

# A Study for Approximation of Magnetic Characteristics

E. Itoda, Y. Ishihara, T. Morino and T. Todaka

Department of Electrical Engineering,  
Doshisha University, Kyoto 602, Japan.

## ABSTRACT

This paper presents an approximate method of magnetic characteristic in any direction and 3-dimensional non-linear calculation which analyzes the laminated core of a transformer.

First, this paper shows the approximate method in case that magnetic characteristic in x-, y- and z-direction are given by  $B=f_x(H)$ ,  $B=f_y(H)$  and  $B=f_z(H)$ . On condition that the magnetizing force  $H$  turns toward a direction shown in Fig. 1, the flux density in x-, y- and z-direction are assumed as follows:

$$B_x=f_x(H_x) \cos \theta, \quad B_y=f_y(H_y) \cos \zeta \quad \text{and} \quad B_z=f_z(H_z) \cos \xi \quad (1)$$

where angle  $\theta$ ,  $\zeta$  and  $\xi$  are shown in Fig. 1. The flux density  $B$  by the magnetizing force  $H$  can be calculated by following equation,

$$|B| = \sqrt{B_x^2+B_y^2+B_z^2} \quad (2)$$

For example, in such a case that a oriented silicon steel with B-H curve shown in Fig. 2 is magnetized by the magnetizing force  $H=(H \cos \theta, H \sin \theta, 0)$ , the magnetization curve of  $B_x$  and  $B_y$  are shown the broken line and one in the same direction as  $H$  is shown the dot-dash-line in Fig. 2. If the angle  $\theta$  approaches  $90^\circ$ , it comes near the  $f_y(H)$ .

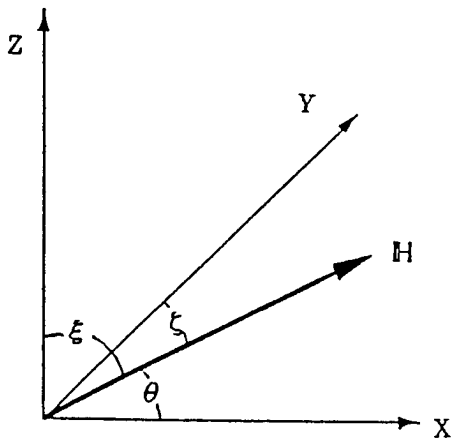

$$H_x = |H| \cos \theta$$

$$H_y = |H| \cos \zeta$$

$$H_z = |H| \cos \xi$$

Fig. 1 The magnetizing force  $H$ .

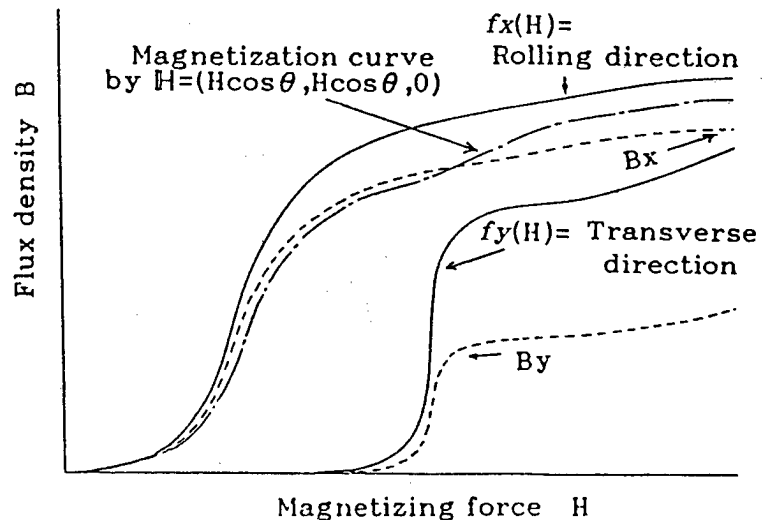

Fig. 2 The magnetization curve.  $(\theta=30^\circ)$

The flux distribution at the laminated coner of a transformer is analyzed by the 3-dimensional finite element method using magnetic scalar potential. The treatment of magnetic characteristic is the above-mentioned method. The non-linear equations are solved by Newton-Raphson iteration technique. The analyzed model is shown in Fig. 3. This figure shows one fourth of the transformer core. The analyzed region is one half of this figure because the periodicity boundary condition is introduced the analyzed model. The value of the specified boundary condition is decided as the average flux density of a leg is 0.7 and 1.7[T]. The eddy current is not considered.

Figure 4 shows the flux density at line A-B and line C-D which are shown in Fig.3. In case of 0.7[T], the flux passes through the air gap very little as shown in Fig.4(b). But in case of 1.7[T], the flux density in the steel above the air gap approaches the value of the saturation induction in Fig.4(a), so that the flux density in the air gap is increased in Fig.4(b).

**ACKNOWLEDGEMENT**

This work was supported by the Grant-in-Aid for Developmental scientific Research from the Ministry of Education.

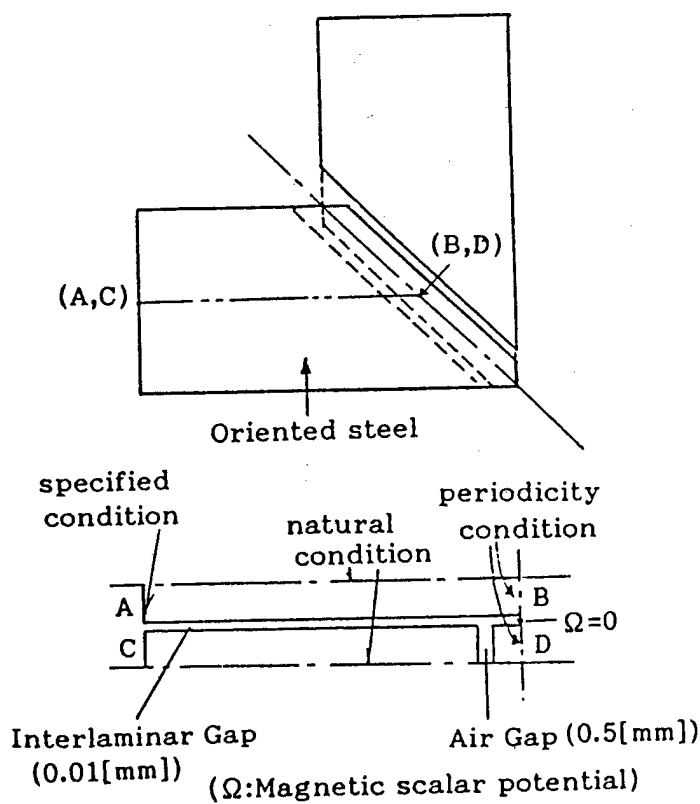

Fig. 3 Analyzed model.

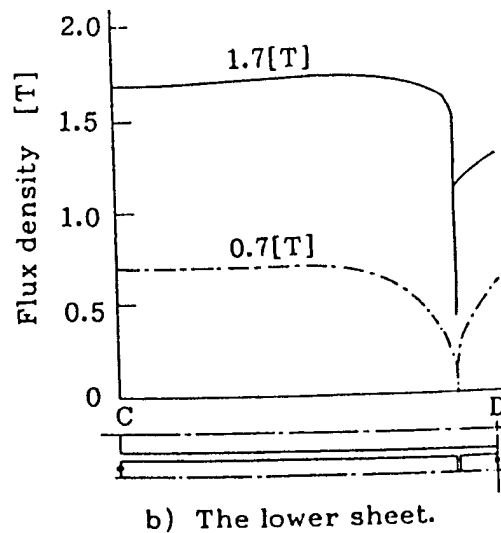
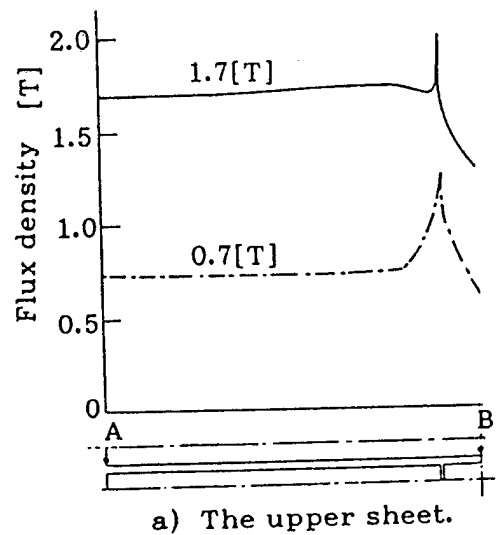

Fig. 4 Flux density in the core.

# SHIELDING EFFECTS OF PERMANENT MAGNETIC ASSEMBLY FOR MRI

H.Sakurai and M.Aoki

Sumitomo Special Metals Co.,ltd.  
Egawa 2-15-17,Shimamoto-cho  
Mishima-gun,Osaka 618,Japan

**ABSTRACT:** Magnetic resonance imaging (MRI) has become more excellent and important for medical diagnosis in recent years. Super conducting magnet has become more popular due to their capability of generating very high magnetic field. On the other hand, permanent magnet has many advantages for the low and medium field range because of their easiness of maintenance and installation.

The permanent magnet assembly for whole body has been developed by using a high energy Nd-Fe-B (NEOMAX) magnet material. Two NEOMAX magnets are used between the pole pieces and a top and bottom plate. These upper and lower sub-magnet assemblies are supported by four columns. Although the magnet assembly has a self shielded configuration, there exists some lower level of leakage flux. These leakage flux might cause some troubles to the patient who has a pace-maker in his body, or electric instrument for imaging.

In this paper, such leakage flux distribution is computed by using a 3-dimensional integral equation method and compared with the observed value. The leakage flux of the permanent magnet system are found to be much smaller than that of super conducting magnet system. Several examples of shielding effects are also discussed with this method.

DESIGN OF THE HYBRID MAGNET  
IN A MAGNETIC LEVITATION SYSTEM  
USING THE BOUNDARY ELEMENT METHOD

Takashi ONUKI, Syunsaku KOGA, Byung Il KWON  
(Waseda University, Tokyo Japan)

With the recent advent of high performance rare earth magnets, we have utilized this kind of magnet in the magnetic levitation system, because of its large coercive force. In our levitation system with both permanent magnet and electromagnet(hybrid magnet), permanent magnets give a base value of m.m.f for levitation while electromagnets produce the m.m.f so as to stabilize the system. This type of levitation, therefore, has less powerloss for levitation than a conventional attraction-type levitation with only electromagnets.

However the hybrid magnet provides a complex magnetic field, so we can not obtain the characteristics of a hybrid magnet system so easily as those of a conventional electromagnet system. In order to solve this difficulty, the parameters in the magnetic circuit are determined by the numerical approach such as the finite element method(FEM) and the boundary element method(BEM). In the boundary element method, only the boundary needs to be subdivided, reducing the number of unknown quantities compared with that of the finite element method. Thus, it is particularly suitable for three-dimensional problem and also to exterior problems. Moreover, various quantities at each point in analyzed region are precisely calculated based on the theoretical expression. For these reasons, we adopt the boundary element method.

In designing the hybrid magnet, the arrangement of permanent magnets has considerable influence on the characteristics. So we first discuss the difference of basic characteristics caused by various arrangements of permanent magnets by two-dimensional analysis.

Secondly we make three-dimensional analysis of hybrid magnets. The voltage equation of the magnetic levitation system involves the leakage inductance. This quantity is derived from the sum of leakage flux. In two-dimensional analysis, it is impossible to consider the phenomena in the longitudinal direction exactly, thus three-dimensional analysis is necessary. Though the vector potential A method is often adopted to solve magnetic problems, we propose H- $\Psi$  method. Here, H denotes magnetic field intensity and  $\Psi$  magnetic scalar potential. The reasons are

- 1) By using scalar potential  $\Psi$ , memories for calculation decreases.
- 2) For determining magnetic flux density B, H- $\Psi$  method results in high precision compared with A method.

The usual boundary integral equation derived from the Helmholtz relationship is

$$4\pi H_0(p) = \int_{\Omega} J_0 \times \nabla \frac{1}{r} d\Omega + \int_{\Gamma} (H \times n) \times \nabla \frac{1}{r} d\Gamma - \int_{\Gamma} (H \cdot n) \nabla \frac{1}{r} d\Gamma \quad (1)$$

In our approach, Eq.1 is modified as Eq.2 by taking inner product with a unit normal  $n_p$ .

$$4\pi C(p)H_0(p) \cdot n_p = \left( \int_{\Omega} J_0 \times \nabla \frac{1}{r} d\Omega \right) \cdot n_p + \left( \int_{\Gamma} (H \times n) \times \nabla \frac{1}{r} d\Gamma - \int_{\Gamma} (H \cdot n) \nabla \frac{1}{r} d\Gamma \right) \cdot n_p \quad (2)$$

In the magnetic core region, we adopt next boundary element equation using the magnetic scalar potential  $\Psi$ .

$$C(p)\psi(p) = \frac{1}{4\pi} \left( \int_{\Gamma} \frac{\partial \psi}{\partial n} \frac{1}{r} d\Gamma - \int_{\Gamma} \psi \frac{\partial}{\partial n} \left( \frac{1}{r} \right) d\Gamma \right) \quad (3)$$

Finally, based on the results of above analyses, we have made the digital control magnetic levitation system which can hold about 80 Kg and we design a controller having an integral mode in order to make the control current zero (zero current control). In addition, to improve the response characteristic we adopt the acceleration feedback control using "In-the-Region Pole Allocation Method".

### 3-D ANALYSIS OF A CYLINDER-TYPE FLUX CONCENTRATION APPARATUS

T.Yoshimoto\*, K.Bessho\*\* and S.Yamada\*\*

\* Ishikawa College of Technology, Tsubata, Ishikawa  
929-03 JAPAN

\*\* Kanazawa University, Kodatsuno, Kanazawa 920 JAPAN

ABSTRACT: This paper deals with three dimensional analysis of a cylinder-type flux concentration apparatus by using a four-component finite element calculation method. We have already examined and analyzed several types of concentration apparatus, which utilize the flux concentration effect of eddy currents [1][2][3]. A new circular, cylinder-type model with several rims is recently developed to improve the flux multiplication factor.

To analyze these models including eddy currents, the four-component  $A-\phi$  method is effective and safe, though it needs a lot of computer memory. Moreover, right combination of boundary conditions for four variables is found to be essential in the calculation. Especially, in order to obtain the z-ward flow of eddy currents, boundary conditions for z-component of the vector potential and the scalar potential have to be examined carefully. We discuss the way of selecting boundary conditions for four variables. The calculation method and the role of the analysis are to be presented as well.

- [1] T.Yoshimoto et al., "3-D Finite Element Analysis of Flux Reflection & Flux Concentration Effects of Eddy Currents", IEEE Trans.on Man., Vol.MAG-22, No5, 834 (1986)
- [2] T.Yoshimoto et al., "3-D Distribution of Flux Density & an Inference about Scalar Potential in a Flux Concentration Model", IEEE Trans.on Magn., Vol.MAG-23, No5, 3041 (1987)
- [3] T.Yoshimoto et al., "Four Component 3-D FEM Analysis of Flux Concentration Apparatus with four Plates", IEEE Trans.on Magn., Vol.MAG-24, No1, 126 (1988)

# Non-Linear Electric Field Computation - In the Space-Charge-Limited Case -

Y. Uchikawa, T. Watanabe, T. Ohye\*

School of Eng. Nagoya University

\* Fac. of Science and Technology, Meijo University

Since the invention of diode vacuum tube, analysis of electron emission under the space charge effect has been a subject of theoretical and experimental interest. Such analyses are indispensable to design a highly efficient electron source which can yield a high beam current with high stability and high spatial uniformity. To investigate into beam forming mechanism in the case of high current density within the beam, trajectory tracing is required through the electric field under the space charge effect. For this purpose, the accuracy of the non-linear electric field computation should be high enough to be able to explain electron motion in a finely focused beam. In this paper we present our numerical investigation to find out the ultimate accuracy of the non-linear computation based upon the Child-Langmuir's formulation of the space charge limited current. Comparative description is made of conventional computational methods to solve non-linear problems, and a new approach is also described.

DEVELOPMENT AND APPLICATION OF HARMONIC BALANCE  
FINITE ELEMENT METHOD IN ELECTROMAGNETIC FIELD

J.Lu S.Yamada K.Bessho K.Hirano

Electrical Energy Conversion Laboratory  
Faculty of Technology, Kanazawa University  
Kodatsuno, Kanazawa, 920, Japan

ABSTRACT: Harmonic balance finite element method (HBFEM) is a new method which is composed of finite element method and harmonic balance method. It can be effectively used to deal with the time-periodic electromagnetic field with nonlinear and hysteresis characteristics and eddy current. Because the HBFEM is worked in the harmonic domain, the time variation does not need to be considered during the calculation. Therefore, the procedure of numerical analysis is almost the same as that of static field. The results of numerical analysis can provide flux distribution, vector potential  $A$ , flux density  $B$  and current density  $J$  for each harmonic component.

This paper not only describes the present work on HBFEM but also its further application to time-periodic electromagnetic field with nonlinear and hysteresis characteristics, and eddy current. For instance, analysis of nonlinear magnetic field connected with voltage sources and

external circuits, where the hysteresis characteristic has been taken into account; the calculation of eddy-current loss and effect of hysteresis in a high-frequency (in MHz region) transformer of resonant converter in which DC component is compounded with AC component; analysis of time-periodic electric field with nonlinear conductivity characteristic; and numerical analysis of sandwiched magnetic materials with different nonlinear and hysteresis characteristics. In addition, the application of HBFEM to some industry purpose, such as, the optimum design of high-speed and hybrid AC motor invented by our Laboratory in 1986, induction heating system and induction electromagnetic pump with AC high magnetic field.

## Numerical Analysis of Magnetic Field in Superconducting Magnetic Energy Storage

Y.Kanamaru, Y.Miyamoto, Y.Amemiya\*

Kanazawa Institute of Technology

Ogigaoka 7-1, Nonoichi, Ishikawa 921, Japan

\*Chiba Institute of Technology

Tsudanuma 2-17-1, Narashino, Chiba 275, Japan

The superconducting magnetic energy storage (SMES) is more useful than the other systems of electric energy storage because of larger storage energy and higher efficiency. The other systems are the battery, the flywheel, the pumped-storage power station. Some models of solenoid type SMES are designed in U.S.A. and Japan. But high magnetic field occurs by the large scale SMES in living environment, it is anxious that high magnetic field causes the error operations of the computer display, the pacemaker of the heart and electronic equipments.

The calculated results of the magnetic field of the solenoid type SMES is described at first in this study. The radius of the storage coil is 200m, the height is 40m and it is in the earth at 150m under the surface of the earth. Its storage energy is 5GWh and the maximum current is 666kA. The maximum magnetic flux density on the surface of the earth is 3400Gauss.

The authors research some suitable designs of magnetic shield for reduction of magnetic field in living environment. When some superconducting shielding coils are over the main storage coil, magnetic field reduces remarkably than the case of non shielding coils. In addition, electromagnetic force of the main coil is dispersed in the main coil and the shielding coils. The calculated results of the magnetic field obtained by the finite element method.

On the other hand, the toroidal type SMES is studied. The leakage magnetic field is lower than the solenoid type SMES. But the electromagnetic force of the coil is very strong. Therefore the large scale model of the toroidal type SMES is unsuitable. The numerical analysis of magnetic field in the small scale toroidal type SMES is described by the analytical calculation.

## Dual Discretization Method for Semiconductor Device Simulator

T.Kojima, Y.Saito and R.Dang  
Graduate School of Engineering, Hosei University  
3-7-2 Kajino Koganei, Tokyo 184, Japan

In order to analyze the field distributions in a reverse-biased semiconductor P-N junction, the dual discretization method utilizing a geometrical dual property between the Voronoi polygons and associated Delaunay triangles has been proposed [1].

This dual discretization method is now applied to the DC current MOSFET problems. This means that the Poisson and current continuity equations are simultaneously solved by means of the dual discretization technique along with the Scharfetter-Gummel algorithm [2].

As a result, it is found that the Scharfetter-Gummel algorithm is also effective to secure stable and accurate solutions from the dual discretization method, and obtained potential as well as carrier distributions agree well with those of the conventional method.

- [1] T.Kojima, Y.Saito and R.Dang, IEEE Trans., Magn. MAG-25, pp.2953-2955(1988)
- [2] D.L.Scharfetter and H.K.Gummel, IEEE Trans., Electron Devices, ED-16, pp16-74(1969)

# An Electro-Magnetic Field Analysis of Two-Dimensional MPD Arcjet Thrusters Using Boundary Element Method

Shinichi SAWAI, Hajime IGARASHI and Toshihisa HONMA

Department of Electrical Engineering, Faculty of Engineering,  
Hokkaido University, Kita 13, Nishi 8, Kita-ku, Sapporo 060, Japan.

## ABSTRACT

MPD (magnetoplasmadynamic) arcjet thruster is one of electric propulsion systems as same as ion engines. We obtain MPD thrust power from the exhaust of plasma accelerated by electromagnetic forces. Aiming at its high performance, in the design and investigation of self-field MPD thrusters at the end of 1960's, effort has been made to understand the physics of the MPD discharge and develop appropriate numerical simulation codes. However, the MPD problems can not be solved easily, because the physics involved are of extreme complexity in contrast to the simple hardware of these devices.

This paper presents the numerical simulation of the current channels and the current distributions on the basis of a one-fluid plasma model, using the boundary element method (BEM) with a simple iteration scheme under the following assumptions : (a) Quasi-steady state, two-dimensional current and one-dimensional self-induced magnetic field conditions are considered. (b) A fully ionized one-fluid plasma model is used, where microscopic phenomena such as the voltage drop across the plasma-sheath and the electrode erosion are neglected. (c) Electron temperature and plasma density are constant in the MPD thruster. (d) Hall and viscous effects are not considered. (e) Ionization process, chemical reactions and heat of reactions are not considered. (f) The plasma flow is steady and one dimensional.

Under above assumptions, the induction equation is derived as follows :

$$\nabla \cdot (-\kappa \nabla \phi) + (\mathbf{v} \cdot \nabla) \phi = -\phi (\nabla \cdot \mathbf{v}) \quad (1)$$

This equation is a kind of convective diffusion equation. Then, the diffusion coefficient  $\kappa$  is referred to  $1/\sigma\mu_0$ , where  $\sigma$  is the electric conductivity,  $\phi$  is an unknown scalar function defined by z component of the magnetic fields. In order to obtain the integral equation corresponding to eq.(1), we apply the fundamental function  $\psi^*$  of Laplace equation, so that



22161

45

NTIS  
ATTN: PROCESS 103  
5285 PORT ROYAL RD  
SPRINGFIELD, VA

22161

This is a U.S. Government publication. Its contents in no way represent the policies, views, or attitudes of the U.S. Government. Users of this publication may cite FBIS or JPRS provided they do so in a manner clearly identifying them as the secondary source.

Foreign Broadcast Information Service (FBIS) and Joint Publications Research Service (JPRS) publications contain political, economic, military, and sociological news, commentary, and other information, as well as scientific and technical data and reports. All information has been obtained from foreign radio and television broadcasts, news agency transmissions, newspapers, books, and periodicals. Items generally are processed from the first or best available source; it should not be inferred that they have been disseminated only in the medium, in the language, or to the area indicated. Items from foreign language sources are translated; those from English-language sources are transcribed, with personal and place names rendered in accordance with FBIS transliteration style.

Headlines, editorial reports, and material enclosed in brackets [ ] are supplied by FBIS/JPRS. Processing indicators such as [Text] or [Excerpts] in the first line of each item indicate how the information was processed from the original. Unfamiliar names rendered phonetically are enclosed in parentheses. Words or names preceded by a question mark and enclosed in parentheses were not clear from the original source but have been supplied as appropriate to the context. Other unattributed parenthetical notes within the body of an item originate with the source. Times within items are as given by the source. Passages in boldface or italics are as published.

#### SUBSCRIPTION/PROCUREMENT INFORMATION

The FBIS DAILY REPORT contains current news and information and is published Monday through Friday in eight volumes: China, East Europe, Soviet Union, East Asia, Near East & South Asia, Sub-Saharan Africa, Latin America, and West Europe. Supplements to the DAILY REPORTs may also be available periodically and will be distributed to regular DAILY REPORT subscribers. JPRS publications, which include approximately 50 regional, worldwide, and topical reports, generally contain less time-sensitive information and are published periodically.

Current DAILY REPORTs and JPRS publications are listed in *Government Reports Announcements* issued semimonthly by the National Technical Information Service (NTIS), 5285 Port Royal Road, Springfield, Virginia 22161 and the *Monthly Catalog of U.S. Government Publications* issued by the Superintendent of Documents, U.S. Government Printing Office, Washington, D.C. 20402.

The public may subscribe to either hardcover or microfiche versions of the DAILY REPORTs and JPRS publications through NTIS at the above address or by calling (703) 487-4630. Subscription rates will be

provided by NTIS upon request. Subscriptions are available outside the United States from NTIS or appointed foreign dealers. New subscribers should expect a 30-day delay in receipt of the first issue.

U.S. Government offices may obtain subscriptions to the DAILY REPORTs or JPRS publications (hardcover or microfiche) at no charge through their sponsoring organizations. For additional information or assistance, call FBIS, (202) 338-6735, or write to P.O. Box 2604, Washington, D.C. 20013. Department of Defense consumers are required to submit requests through appropriate command validation channels to DIA, RTS-2C, Washington, D.C. 20301. (Telephone: (202) 373-3771, Autovon: 243-3771.)

Back issues or single copies of the DAILY REPORTs and JPRS publications are not available. Both the DAILY REPORTs and the JPRS publications are on file for public reference at the Library of Congress and at many Federal Depository Libraries. Reference copies may also be seen at many public and university libraries throughout the United States.