

Ad  
UN

New Text Document.txt

14 January 1998

This paper was downloaded from the Internet.

Distribution Statement A: Approved for public release;  
distribution is unlimited.

Date: 12 November 1996

19980121 084

# Concept of Operations for the Pilot Maritime Battle Center (MBC)

November 12, 1996

## Introduction

As recently as thirty years ago, the pace of technology was sufficiently slow that DoD operational requirements could greatly influence the direction and pace of technological development. But the tables have turned and many new operational requirements are created largely because technology makes them feasible. As can be seen in figure 1, the technology of the battlefield will always trail that of the technologist. But, by casting off the old paradigm of cyclic insertions of technology and embracing a process of near-continuous insertions, the gap between the technology of the warfighter and that of the technologist begins to narrow.

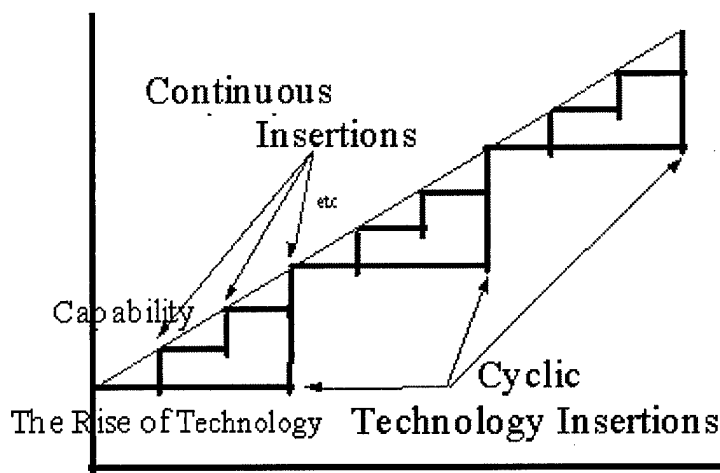

Fig. 1

In order to retain dominance in the battlespace, the warfighter must harness technology and apply it to operational purposes in parallel with its development. This calls for a new model and partnership between the technologist, tactician, and the warfighter. The Maritime Battle Center is the hub that optimally joins these entities and allows the rapid development and fielding of sophisticated warfighting systems. The MBC will provide the infrastructure necessary to perform cost effective research, development, and test and evaluation of hardware, software, and doctrinal development in Maritime C4ISR. It will serve as a tool to enable implementation of the Navy, Marine Corps and Coast Guard's C4ISR strategy and it will serve as the Maritime node of the Joint Battle Center.

The Concept of Operations described herein addresses the composition and operations of a Pilot MBC, which will encompass all activities of the final MBC but focuses solely on the SPAWAR claimancy. Requirement for a SPAWAR based Pilot MBC derives from OPNAV N6 letter Ser N6C/6U555165 of 8 October 1996 which directs SPAWAR to "Develop a Pilot Maritime Battle Center (MBC)."

The Pilot MBC will be designed such that the interaction between the technologist, tactician, and warfighter is optimized. This will ensure that the users will embrace the MBC as a tool in their efforts to develop, test, and deploy technology. The MBC infrastructure will be lean, initially leveraging existing SPAWAR test, evaluation, and training assets (labs, ranges, modeling and simulation, etc.), but eventually expanding to include all applicable Maritime and Joint resources. It will be a small core organization making maximum use of distributed computer systems, networks, and data collection and dissemination methods. Products will be integrated and tested in a test environment created as a system of systems. To ensure new equipment and systems can be seamlessly tested and integrated, a common operating environment based on an open standards-based architecture will be strongly promoted.

The Pilot MBC will support the interoperability of Joint and "Copernicus...Forward" architectures. The success of the MBC will be measured by the smoothness with which it can work with product developers to rapidly test and evaluate their products, participate with product users to provide quality warfighting tools, and coordinate with product managers to bring new technology to the warfighter as cost effectively as possible.

**Functions**

The Pilot MBC is a reconfigurable C4ISR capability that interconnects existing SPAWAR claimancy technical facilities and laboratories to:

- provide resources where the warfighter and technologist can see, touch, and feel the C4ISR capabilities to be used in combat; a place to experiment, learn, and experience the future;
- enable Maritime forces to rapidly move forward in dominant battlespace control with fully interoperable leading edge systems;
- support the acquisition cycle, from initial concept to end of life; and
- enable distributed simulation, technology insertion, analysis, testing, integration, and Fleet support.

The Pilot MBC is a scaleable capability with the ability to support configurations from the system level to the theater level. It serves as a focal point for Maritime system of system (SOS) engineering coordination, as a knowledge base of hands-on SOS integration expertise, and as a tool for system developers, testers, certifiers.

**Organization**

The Space and Naval Warfare Systems Command Chief Engineer, SPAWAR 05 has been tasked by OPNAV N6C to establish the Pilot Maritime Battle Center using SPAWAR claimancy assets. As the Navy's lead C4ISR laboratory, the Naval Command, Control and Ocean Surveillance Center (NCCOSC) and its Research and Development Division (NRaD) have been tasked by SPAWAR to provide technical and engineering support to assist in the development and implementation of the Pilot MBC. Representation from the Marine Corps Commandant's Warfighting Center (CWL) and the Coast Guard C2 Lab is included in the Pilot MBC to provide a true Maritime involvement in MBC from inception.

Initially the Pilot MBC will be comprised of two Integrated Product Teams (IPTs):

- Overarching IPT (OIPT)
- System Engineering and Integration IPT (SE&I IPT)

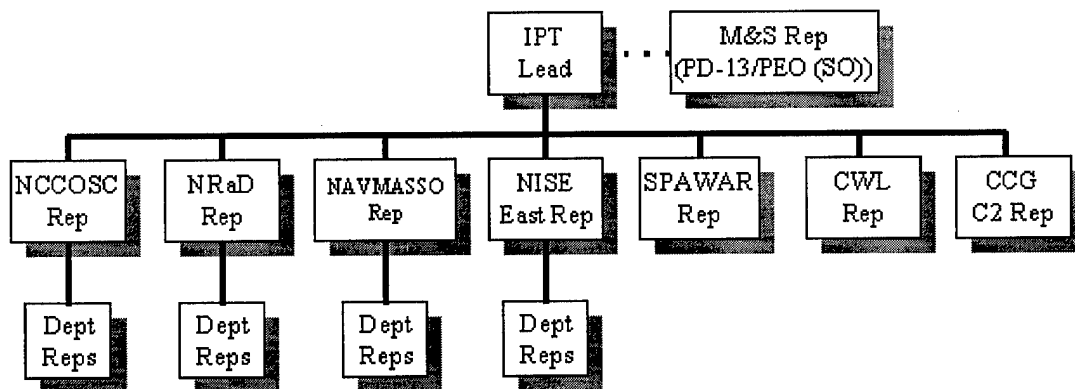

**Figure 2 Pilot MBC Overarching Integrated Product Team (OIPT)**

The Overarching Integrated Product Team is responsible for the implementation of the Pilot Maritime Battle Center capability. The OIPT is a standing committee with designated membership. It will provide the primary programmatic interface between OPNAV / SPAWAR program offices, the SPAWAR claimancy assets, and the MBC users / customers. The Pilot MBC OIPT will:

- provide insight to the product managers, product builders, and product developers with regard to capabilities inherent in the Pilot MBC;
- facilitate Pilot MBC support to the product managers, product builders, and product developers in view of their requirements;
- support the product managers, product builders, and product developers as the Navy's single point of entry into the Joint Battle Center;
- be proactive in gaining insight into the needs of the product managers, product builders, and product developers with respect to the capabilities of the Pilot MBC;
- serve as the "kernel" for the implementation of the full Maritime MBC, in support of OPNAV N6C at conclusion of the Pilot program;
- execute the program and direct the activities of the SE&I OPT.

The Pilot MBC OIPT reports to OPNAV N6C through SPAWAR 05.

The System Engineering and Integration IPT (SE&I IPT) is an ad hoc committee formed to execute OIPT directions for a particular test, exercise or demonstration. Each SE&I IPT is responsible for identifying, architecting and integrating the networks and systems for a particular Pilot MBC event. Membership for each SE&I IPT will be determined by the requirements of the particular event.

An initial SE&I IPT has been formed to provide engineering support to the OIPT for the standup and development of the Pilot MBC program itself. Responsibilities of the initial SE&I IPT are to provide OIPT and SPAWAR program management team with the technical details to formulate the Pilot MBC program plans. Technical support includes:

- identify the resources required to stand up the Pilot MBC;
- define the initial architecture for Pilot MBC systems;
- develop an implementation plan;
- engineer Phase 0 test to demonstrate the purpose and power of the MBC concept to gain endorsement from Claimancy stakeholders; and
- assist the Phase 1 SE&I IPT in developing the MBC JWID'97 involvement.

For consistency, a small standing SE&I IPT will be identified to assist the OIPT in formulating and directing subsequent ad hoc SE&I IPTs. All SE&I IPTs report directly to the Pilot MBC OIPT.

## Products

In support of Pilot MBC start up, the following minimum set of products will be developed during FY97.

a. Programmatic documentation produced for the Pilot MBC will be:

- (1) Charter
- (2) POA&M
- (3) CONOPS
- (4) Implementation Plan
- (5) Business Plan
- (6) Configuration Management Plan

b. Tools to enhance information exchange will be:

- (1) Executive Level Program Briefing
- (2) Scheduling and Engineering Tool, which is a web based tool that will provide the user

with information that pertains to a particular lab/facility in terms of the composition of equipments and capabilities as well as the scheduling of these assets within the labs/facilities. This tool will facilitate collaborative engineering in support of Pilot MBC run tests, exercises and demonstrations.

(3) Web Site:

(a) The Electronic Library section of the web page will contain all programmatic documentation, briefings, test data, lessons learned, etc. and provide a means for commenting against any posted document. This area will be unclassified but domain filtering will be employed to preclude the information from being available to the general public; and

(b) The Scheduling and Engineering section of the web page will contain the Scheduling and Engineering Tool (described below) as well as detailed engineering data, such as system designs/configurations from past and present tests supported by the Pilot MBC.

c. Experiments / tests / demonstrations for FY97 will be primarily centered around two phases.

- Phase 0 will be a modest test structured to demonstrate the ability to link three or more laboratories into a virtual environment which mimics a Fleet environment. Scope of the test will be limited to SPAWAR claimancy assets. Purpose of this test is to highlight MBC's ability to provide a virtual environment for testing and validating certain architectures prior to actual implementation and to show the utility of the laboratory infrastructure to support integration and interoperability testing early in the acquisition cycle.

- Phase 1 will apply the assets of the Pilot MBC to facilitate systems integration engineering to support the Maritime Community's participation in JWID'97. Current proposed role is focused on providing a virtual Battle Group to support selected demonstrations which would be inappropriate and/or premature to demonstrate in the real environment.

### Work Flow

The Pilot Maritime Battle Center is not a developer, tester, nor evaluator of C4ISR technologies in its own right. It serves as the vehicle and experimental environment for outside activities to develop, test, and evaluate new systems, equipment, and doctrine. Technologies are nominated as potential candidates for MBC experimentation by a wide range of potential product developers including academia, industry, syscoms, maritime laboratories / warfare centers, or the Joint C4ISR Battle Center. Experiments, tests and demonstrations are designed as needed to test the technology using a mix of real, virtual, and constructive models and systems. The results of these experiments are evaluated and those technologies that are successful are implemented based on the needs of the operating forces. Figure 3 shows the technology implementation cycle.

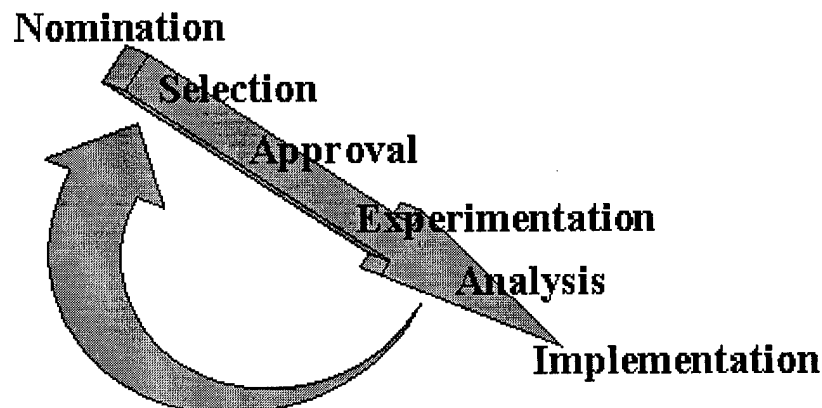

### Figure 3

#### Future Roles and Organizational Relationships

The Pilot MBC has been designated as a SPAWAR Claimancy initiative with a requirement to involve the Marine Corps and Coast Guard as much as possible. However, the Pilot MBC is also designated from the onset to be a microcosm of the ultimate Maritime Battle Center, which will encompass all Maritime organizations and agencies. In this capacity the Pilot MBC must develop as a representative system analogous to the final larger system in purpose, configuration, and processes. This section of the document discusses the larger context into which the Pilot MBC must mature and evolve. Knowing the end-state is vital to discerning the way ahead.

Both the Pilot and the final MBC will service as the single point of access between the Joint C4ISR Battle Center and the Maritime (Navy, Marine Corps and Coast Guard) operating forces, warfare centers, labs, industry, academia, and test and evaluation sites. It will provide the framework, network, conventions, standards, and protocols for the introduction and evaluation of new technology within the maritime warfighting environment. The MBC will provide an arena where the technologist, tactician, and warfighter can gather for the purpose of sharing ideas and testing and evaluating concepts, equipment, systems, and doctrine. It will integrate the needs of the warfighter with state-of-the-shelf technology. Ideas and technologies will be sought from all interested parties, the operators, engineers, scientists, representing the military, industry, and academia.

Consistent with the alignment of the Department of the Navy, the MBC will be closely aligned with each of the Fleet Commanders-in-Chief, commanders of the numbered fleets, Fleet Marine Forces, Type Commanders, and the operating commands in the Navy and Marine Corps. Thus the MBC must be finely tuned to the concerns and needs of the operational chain of command. Additionally, some of the work done at the MBC will include the participation of actual fleet units, in port and at sea. There must be an avenue for planning and executing exercises. The ability to communicate and work together will be paramount to the success of MBC taskings. In addition, participation in existing Maritime requirements working groups, such as the Copernicus Requirements Working Group (CRWG), will be an important means by which MBC will learn and appreciation requirements of the operating forces.

The Maritime Battle Center will provide a new type of laboratory environment for the technologists and tacticians. Navy and Marine Corps System Commands, Warfare Centers, and Tactical Development Centers are expected to use the MBC to test and evaluate C4ISR tactics, doctrine, and equipment. The Systems Commands have technological and management expertise and the ability to streamline the acquisition process. When promising technologies are identified there must be support within the system command community to ensure the vitality of these initiatives. Navy and Marine Corps doctrine commands will be able to test new warfighting ideas more effectively and less expensively, both in terms of money and manpower.

The Maritime Battle Center will depend upon both virtual, constructed, and live sources of data and C4ISR activity. This will require connectivity with existing training, test and evaluation ranges. These ranges can be used to test real time scenarios which can provide actual data to the evaluation process. This real data can be integrated with virtual data to thoroughly stress systems under evaluation. In a like manner, inputs and outputs to fleet units, whether in port or at sea, can add immeasurably to the realistic evaluation process. Additionally, the early involvement of the test and evaluation community will be critical to the rapid development and procurement of C4ISR systems.

The research and development community is composed of the Navy laboratories, industry, and academia. The Maritime Battle Center will allow them to try out new theories and test concepts and equipment without impacting the operating forces. This will bring significant economies to the development and procurement processes. We can no longer afford to develop military systems in a vacuum. The time has come for a partnership where industry and the defense community

share resources, ideas, and expertise. The MBC will provide the opportunity to conduct meaningful test and evaluation before a major investment of time and money has been committed.

The MBC will be the maritime support arm of the Joint Battle Center. Because of their common roles and missions the MBC will derive a variety of benefits from the JBC. Not only will the MBC leverage JBC technological advancements and capabilities but it will also benefit from process changes demanded by the JBC. The MBC will serve as a source for advanced information and C4ISR technology for JBC assessment or potential technology insertion. To facilitate advanced experiments with Joint staffs and Component Commanders, the MBC will be networked with the JBC and the other Service battle labs, creating a "virtual Joint Task Force." The MBC will offer the opportunity to evaluate C4ISR interoperability issues without the cost of moving Navy systems to the JBC. It will serve as the JBC's point-of-entry to Navy intelligence, surveillance, and reconnaissance resources and the source of real time maritime sensors, data links, and combat control systems. The MBC will be the single point-of-entry for all maritime issues and concerns to the JBC.

### **Pilot MBC Business Process**

Funding for the Pilot Maritime Battle Center will be derived from shared resources of OPNAV, SPAWAR and product developers / testers / demonstrators. Every effort will be made to leverage the capabilities and facilities of participating activities in order to minimize both the costs and infrastructure needed to operate the Pilot MBC. The OIPT will develop a Business Plan which will lay out the plan for allocation of resources within the Pilot MBC organization and identify how the Pilot MBC will conduct its business. Heavy emphasis will be place on the establishment of Integrated Product Teams and Working Groups composed of a broad range of experts representing product developers, builders, managers, and users.