

JPRS-TTP-89-006
16 MAY 1989

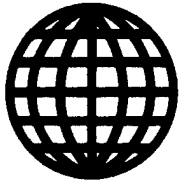

**FOREIGN
BROADCAST
INFORMATION
SERVICE**

JPRS Report

Telecommunications

DISTRIBUTION STATEMENT A

Approved for public release;
Distribution Unlimited

DTIC QUALITY INSPECTED 2

19980202 160

REPRODUCED BY
U.S. DEPARTMENT OF COMMERCE
NATIONAL TECHNICAL INFORMATION SERVICE
SPRINGFIELD, VA. 22161

Telecommunications

JPRS-TTP-89-006

CONTENTS

16 May 1989

SUB-SAHARAN AFRICA

INTER-AFRICAN AFFAIRS

- ITU Official Discusses Rascom's Objectives [Paris *JEUNE AFRIQUE ECONOMIE*, Mar 89] 1

EAST EUROPE

GERMAN DEMOCRATIC REPUBLIC

- GDR's ISDN Packet Switching Module Described
[Steffen Rommeck, Horst Kollosch; East Berlin *NACHRICHTENTECHNIK-ELEKTRONIK*,
No 1, 89] 5

NEAR EAST & SOUTH ASIA

INDIA

- Private Satellite Network Planned for Mid-1989 [Calcutta *THE TELEGRAPH*, 8 Mar 89] 7
INSAT-II Test Spacecraft To Launch Mid-1990 [Delhi Radio, 16 Apr 89] 7
Minister Announces TV Coverage Expansion Plan [Delhi Radio, 15 Apr 89] 7
Tata Institute Radiotelescope in Soviet Project [Madras *THE HINDU*, 11 Mar 89] 7
Minister on Satellite Facilities, U.S. Computer [Delhi Radio, 24 Apr 89] 8

IRAN

- New Ground Satellite Station Established [Tehran Radio, 7 May 89] 9

OMAN

- Minister Discusses Expansion of Telecommunication Services [Muscat *AL-WATAN*, 27 Feb] 9

QATAR

- Telecommunications Grid Reviewed [Doha *AL-'ARAB*, 22 Feb 89] 10

UNITED ARAB EMIRATES

- Abu Dhabi to Have New Meteorological Satellite Receiving Station
[Muhammad 'Uthman; Dubayy *GULF NEWS*, 24 Mar 89] 11

WEST EUROPE

EUROPEAN AFFAIRS

- TAT-8: Fiber Optics Crosses Atlantic
[Denise Frilloux; Paris *MESSAGES*, No 381, Dec 88-Jan 89] 13
EC Official Assesses Telecom Reforms
[Chichester *INTERNATIONAL TELECOMMUNICATIONS INTELLIGENCE*, 24 Mar 89] 14

BELGIUM

- Alcatel Plans Digital Exchange Contract With USSR 15
Advanced Negotiations [Groot-Bijgaarden *DE STANDAARD*, 8 Feb 89] 15

Belgians Approve First Phase
[Chichester *INTERNATIONAL TELECOMMUNICATIONS INTELLIGENCE*,
10 Mar 89] 15

CANADA

Ruling on Telecommunications Regulation Reported Near
[Angela Barnes; Toronto *THE GLOBE AND MAIL*, 21 Mar 89] 16

Rogers Communications Announces \$1.1 Billion Program
[Adam Mayers; Toronto *THE TORONTO STAR*, 30 Mar 89] 17

Ontario Cuts Contribution to Radarsat Satellite Project
[Ottawa *THE OTTAWA CITIZEN*, 11 Mar 89] 18

CBC Eyeing U.S. Market for Programs by Satellite
[John Partridge; Toronto *THE GLOBE AND MAIL*, 14 Apr 89] 19

TV License Renewal Ties Canadian Content Spending to Revenues
[Toronto *THE GLOBE AND MAIL*, 7 Apr 89] 20

Low-Powered Microwave TV System Available for Remote Areas
[Toronto *THE GLOBE AND MAIL*, 18 Mar 89] 20

FRANCE

Universal Network Breakthrough, 'Numeris'
[Laurence Reboul; Paris *MESSAGES*, No 381, Dec 88-Jan 89] 21

Alcatel Firm Profits from CEMA Relaxation
[J.P. Jolivet; Paris *L'USINE NOUVELLE*, 9 Mar 89] 23

NORWAY

Country Seen Wanting Out of TELE-X Project [Rolf Larsen; Oslo *AFTENPOSTEN*, 10 Mar 89] ... 24

SPAIN

Northern Telecom-Amper Negotiating Switchboard Agreement
[P.G. Cuartango; Madrid *DIARIO* 16, 18 Mar 89] 25

SWEDEN

Digital Switching Stations From Ericsson [Stockholm *DAGENS NYHETER*, 15 Mar 89] 26

INTER-AFRICAN AFFAIRS

ITU Official Discusses Rascom's Objectives 55000013 Paris JEUNE AFRIQUE ECONOMIE in FrenchMar 89 pp 96, 98-101

[Interview with ITU vice-secretary-general Jean Jiguep by Jean-Pierre Bejot: "Dakar-Harare by Satellite"; first eight paragraphs are JEUNE AFRIQUE ECONOMIE introduction]

[Text] While radio, television, and telephone service is still unequally distributed, Africa is improving its equipment with the help of the ITU [International Telecommunications Union]. The development of the continent depends on it.

There is a delightful anecdote, as current now as when it happened a few years back. The scene is a well known restaurant in Geneva, where some of the most important French and African figures in telecommunications sector development has gathered for a dinner hosted by Gerard Longuet, then French minister of Postal Services and Telecommunications. At the African ministers' table, the conversation was lively, revolving mostly around telecommunications and...soccer: the European Cup, a hot topic if ever there was one, was being played. One of the dinner guests leaned my direction and said, "How do you expect us to be able to interconnect our telecommunications networks when we see the trouble we have in Africa organizing an African soccer cup?" This apparently innocuous remark effectively illustrates Africa's telecommunications problems.

Ten years ago, Africa set a goal of for the 1978-1988 decade of installing 1 telephone, 20 radios, and 2 television sets for every 100 inhabitants.

Today, the only countries to have met that goal are Botswana, Cape Verde, Guinea-Bissau, Ivory Coast, Kenya, Morocco, Swaziland, Tunisia, and Zambia. Tunisia has 4 telephones per 100 inhabitants, Kenya 1.4, and Ivory Coast 1.3. Results for radios and televisions remain unsatisfactory. Angola has 1.4 radios, Mozambique 3.6, Tanzania 4.1, and Ethiopia 4.5.

Increasing Inter-African Links

When it comes to television sets, while Tunisia leads the pack with 11.92 per 100 inhabitants, followed by Algeria with 7.35, and Nigeria with 6.04, other countries are less well equipped. The Central African Republic has only 0.11, Ethiopia 0.15, and Uganda 0.60.

However, Africa does have a project aimed specifically at decreasing disparities among the various countries and increasing inter-African links: the Regional African Satellite Communications System for the Development of Africa, better known under its code name, RASCOM.

This ambitious project (the study alone will cost over \$7.5 million) has been undertaken within the framework of a Special Interinstitutions Commission made up of the president of the Organization of African Unity (OAU), the vice-chairman of the Economic Commission for Africa (ECA), and representatives of other regional organizations and institutions. The first step will be to compile the studies already made on the subject in order to draw up a report detailing telecommunications scenarios and appropriate choices. The goal is to integrate space-based technologies and national networks adequately in order to provide quality service to rural and isolated areas of the continent.

This project, crucial to the future of Africa, is coordinated by the ITU. ITU Vice Secretary General Jean Jiguep agreed to speak with us about his agency's activities in Africa and the RASCOM project.

Jean Jiguep: "Let Us Solder the Missing Link"

[JEUNE AFRIQUE ECONOMIE] The International Telecommunications Union was founded in 1865 and is the oldest specialized agency of the United Nations. Could you give us a brief history of its role and activities, especially in Africa?

Jean Jiguep: The ITU is in fact the oldest international governmental organization and has been continuously active. It was founded in 1865 as the International Telegraph Union and changed its name to the International Telecommunications Union following adoption of the International Telecommunication Convention in 1932.

The ITU has been involved in Africa for decades, mainly in the area of technical cooperation. Technical cooperation activities in Africa fall into three major categories: developing networks on a regional level—through PANAFTEL [Pan-African Telecommunications Network], for example—and on a national level, through the national master plans for telecommunications development; improving telecommunications services and management; and developing human resources by creating and improving training centers or by organizing workshop-seminars, such as the one on signaling systems held in Botswana from 7 to 9 March 1988 for English-speaking African countries.

[JEUNE AFRIQUE ECONOMIE] Could you describe the ITU's organizational structure for us, especially with regard to Africa?

Jean Jiguep: The ITU is made up of seven different organizations: the Plenipotentiary Conference; the administrative conferences; the Administrative Council, and four permanent organs: the General Secretariat, the International Frequency Registration Board (IFRB), the International Radio Consultative Committee (CCIR), and the International Telegraph and Telephone Consultative Committee (CCITT).

The ITU General Secretariat, which includes the Department of Technical Cooperation, is headed by a secretary general, who is assisted by a vice secretary general. The Department of Cooperation, a part of the ITU General Secretariat, includes geographic divisions such as the African Division, an administrative division, a professional training division, and an engineering group. The African Division includes project administrators for the three zones—West Africa, Central Africa, and East and Southern Africa—who are based in Dakar, Yaounde, and Harare, respectively.

It should be noted that the senior representative for all of Africa is in Addis Ababa, at the Economic Commission for Africa (ECA).

[JEUNE AFRIQUE ECONOMIE] Telecommunications is becoming a full-fledged sector in the economies of developing countries. How does the ITU see the place of telecommunications in development policy?

Jean Jipguep: For several decades, the ITU has been encouraging member states and regional and subregional economic institutions to consider telecommunications as an infrastructure investment on a par with electricity, highways, and railroads. More recently, within the framework of World Communications Year, in 1983, the ITU undertook a series of studies on the impact of telecommunications on economic and social development.

These studies showed that telecommunications are both a cause and a consequence of development. Specifically, they pointed to the existence of a correlation between telephone density and per-capita income. The lower a country's per-capita income, the more telecommunications contribute to the economic development of the country.

[JEUNE AFRIQUE ECONOMIE] In other words, telecommunications now constitutes an indispensable, irreplaceable tool in a country's economic and social development process?

Jean Jipguep: This has now been amply proven. The Independent Commission for World Telecommunications Development summarized its findings in a report, "The Missing Link." These findings confirm once again that without appropriate telecommunications services, many development activities cannot succeed.

The ITU has published a document called "Information, Telecommunications, and Development." This publication points to the growing importance of the telecommunications sector, as well as to the information needs of a number of developing countries and regions (islands in the Pacific and rural regions of small African countries). In these areas, telecommunications and the local and national economy are more and more closely linked. In

addition, the ITU has published some interesting information on the value and contribution of telecommunications from the standpoint of foreign currency earnings in small African countries, and on transportation. The ITU has also published a more general macroeconomic study on the role of telecommunications in the economies of a number of countries. All these works show the importance of telecommunications in economic development, not just for the industrialized world, but also, to a perhaps greater extent, for the developing world.

[JEUNE AFRIQUE ECONOMIE] What is the current perception in Africa of the role of telecommunications in the development process?

Jean Jipguep: For a long time, too great a distinction was made throughout Africa between the direct profitability of investments and overall profitability for the economy as a whole. The ITU has greatly contributed to changing this approach, in order to change the way in which the factors considered in telecommunications investments are weighted. Also, the lack of foreign currency limits possibilities for joint operations based on contracts between the North and the South. For this reason, the independent commission strongly recommended that donors and multilateral lending institutions grant very favorable conditions on loans for investments in Third World countries, knowing that these investments can be generally profitable if there is an equilibrium between rural and urban development.

[JEUNE AFRIQUE ECONOMIE] The ITU's cooperation activities in Africa are extremely diverse: training, planning, advice, and technical assistance. Could you tell us what kinds of projects are now in progress and which African countries are benefiting from them?

Jean Jipguep: The ITU's technical cooperation activities in Africa are indeed extremely diverse and are implemented on regional, subregional, and national levels. In recent years, with the assistance of the ITU, over 20 African countries have acquired national telecommunications development plans defining the major axes of development over a 20-25-year period. Each long-term plan is accompanied by a short- and medium-term investment program, together with a financial study. Among the countries having master plans are Cameroon, Ivory Coast, Mauritius, and, more recently, Mali, whose plan is nearing completion.

The ITU has helped, and continues to help, a number of countries to set up or consolidate their institutes or centers for professional telecommunications training. A few cases in point are the Oran Telecommunications Institute in Algeria, the National School of Postal Services and Telecommunications in Burkina Faso, and the Telecommunications Training Center in Zimbabwe.

From time to time, the ITU helps government telecommunications offices in drawing up the technical specifications needed to issue requests for bids for the purchase and installation of new equipment or to participate in technical reception measures for a new telecommunications installation.

[JEUNE AFRIQUE ECONOMIE] What are your activities at the the subregional and regional level?

Jean Jiguiep: At the subregional level, mention should be made of the Rufisque Multinational School of Telecommunications in Senegal, which has been superseded by the Dakar Multinational Higher School of Telecommunications and trains higher level technicians for the French-speaking countries of West Africa. Another school, the African Advanced Level Training Institute (AFRALTI), which opened recently in Nairobi, Kenya, provides ongoing initial training for management personnel in East and Southern Africa. At the level of the continent, the ITU has been working for several years with the OAU, ECA, ADB [African Development Bank], and the UPAT [Pan-African Telecommunications Union] to develop a pan-African telecommunications network. The basic goal of this network remains the implementation of a quality telecommunications system to allow communications in and among all countries without relaying through another continent. In certain regions, such as East Africa and, to a certain extent, West Africa, the pan-African network has made enormous progress. In Central Africa, however, it is still marking time.

[JEUNE AFRIQUE ECONOMIE] The Regional African Satellite Communications System for the Development of Africa (RASCOM) is one of the major projects in which the ITU is participating. What is the current status of the feasibility study for this project?

Jean Jiguiep: The main objective of the RASCOM feasibility study is to identify the telecommunications needs (including radio broadcasting) of the various participating countries so that a viable set of technical and economic solutions can be proposed. These solutions will use a regional satellite telecommunications system and other technical applications to meet the needs of the various countries.

The feasibility study for the RASCOM project is in progress. The national component, undertaken with the participation of the pluridisciplinary national coordination committee in each country in Africa, has just been completed. The year 1989 will be devoted for the most part to regional activities revolving around the concept of an integrated telecommunications network for the African continent. The regional study will be based on the information in the national study reports and will deal essentially with the ground-based and satellite systems.

The goal with respect to ground-based systems will be to identify all the elements involved in implementing an integrated rural network, including cost. The main items to

be examined will be subscriber access methods and systems, long-distance communications installations, rural switching systems, and electrical power supply systems. The regional study will also focus on the the design of rural network models adapted to the African environment.

The goal with respect to satellite systems will be essentially to evaluate the various implementation options. For this purpose, the RASCOM project office, which is a part of the ITU, will bring in consultants to take charge of the following studies: configuration, design, and evaluation of space-based communications system options; financial and socio-economic evaluation of proposed options; satellite system management options and legal aspects; and options comparison. The project is scheduled for completion around mid 1990 so that the results can be presented at the conference of African transportation, communications, and planning ministers in August 1990.

[JEUNE AFRIQUE ECONOMIE] What about financing for the feasibility study?

Jean Jiguiep: The RASCOM feasibility study is being financed by contributions from the African Development Bank (ADB), the United Nations Development Program (UNDP), the Organization of African Unity (OAU), the ITU, UNESCO, Italy, and the FRG. The cost of the feasibility study is estimated at \$7.5 million—2.25 billion CFA francs.

[Boxed item, p 99]

A Well-Connected Cameroonian

At 51, Jean Jiguiep is a leading figure in the world of telecommunications. Born in Bafoussam, Cameroon, he studied at the colleges of science at Paris and Strasbourg, where he received a degree in physics and applied mathematics. He also attended the Strasbourg Institute of Geophysics from 1962 to 1964 and the ENST [Ecole Nationale des Sciences de Technologie—National School of Science and Technology] in Paris, from which he received a degree in engineering. Once he had finished his education, he returned Cameroon, where he entered the postal services and telecommunications administration. There he worked his way up the ladder, going from engineer at the Postal Services and Telecommunications federal headquarters in Yaounde, to head of the Federal Telecommunications Service in Douala, to assistant director of telecommunications responsible for technical services, to director of telecommunications from 1972 to 1978. During this period he oversaw the implementation of Cameroon's telecommunications development program: 34 automatic telephone exchanges, 5 national and regional group centers, an international group center, and 3,200 kilometers of microwave links completed by a 3-antennae "space" center. As vice secretary general of the ITU, he has participated actively in the labors of the African telecommunications organizations for over 15 years.

[Boxed item, p 101]

RASCOM's Feasibility

The RASCOM project has two ultimate goals: to provide all the regions of Africa with efficient, economical telecommunications equipment and to meet their radio and television broadcasting needs using all appropriate technologies. This system will be integrated into existing or projected national networks in order to encourage the development of African countries.

For Africa as a whole and for the rural areas in particular, the immediate goals of the feasibility study include identifying satellite communications needs and proposing services to meet them; carrying out technical and economic studies for the design; implementing and operating a regional satellite communications system to provide efficient, economical telecommunications; and preparing specifications for the design and, if possible, local production of all equipment required for the integrated regional system, taking into account the African economic, social, technological, and physical environment.

At the national level, the basic aim is to identify each country's real development-oriented needs in the area of telecommunications services. Each country will involve the users to a great extent in determining its needs. It will approach the problem of access to telecommunications services not only from the angle of traditional demand for telephone and telex service, which is the customary telecommunications administration viewpoint, but also from that of those responsible for overall national development, who see telecommunications access as an infrastructure support. Pluridisciplinary national coordination committees (CCN's) have been set up to meet this

objective. In each African country, a national coordinator has been appointed to direct the activities of committee members.

Each CCN includes senior officials from ministries of rural development, agriculture, radio and television broadcasting, interior, trade, planning, economic development, transportation, and telecommunications.

Given the importance of national-level activities in carrying out the RASCOM feasibility study, the project office's first priority was to draw up a document entitled "Guidelines for National-Level Realization of a Feasibility Study for a Regional African Satellite Communications System for the Development of Africa." The purpose of this document is to provide national coordination committees with the information that they need to undertake the national feasibility studies.

One of the major activities involved in a national feasibility study is analysis: analysis of existing parameters and social conditions, analysis of rural telecommunications requirements, and analysis of the current and long-term status of radio and television broadcasting needs. Another major activity is the listing of necessary goods and services; another is financial and economic evaluation. Regional-level feasibility studies will examine many of the same topics as the national studies. Although the specific needs of each country will be taken into account, the emphasis will be on the regional aspect of the project.

Among the topics to be considered in the regional study are an African regional system database; evaluation of telecommunications bids; regional telecommunications planning goals, including radio and television broadcasting; and provisions for distributing traffic among the ground-based and satellite systems.

GERMAN DEMOCRATIC REPUBLIC

GDR's ISDN Packet Switching Module Described

23020053 East Berlin NACHRICHTENTECHNIK-ELEKTRONIK in German No 1, 89 pp 6-7

[Article by graduate engineer Steffen Rommeck and doctor of engineering Horst Kolloshie of Dresden Polytechnic Institute, Department of Information Technology: "Coupling Data Networks"]

[Text] The packet communications module (PCM) serves to connect the data network developing in the GDR, which is secured by means of packets (PVDN) with a future ISDN, which is envisioned as a module for the ISDN-compatible communications central, DPC.

The modular structure of the PCM makes flexible use possible, not only within the context of the data processing central, but also as a packet nexus in a packet network, or in the ISDN. Based on the projected transformation to higher bit rates (48 or 64 kbit/s), and the possibility of adding several virtual connections by means of an X.25 interface, the result could be an increase of traffic handled by the PCM. As a result of the PCM's modular construction, it is possible to adapt the latter to the projected volume of traffic, and to vary the number of channels in keeping with the flow rate and the required packet lingering period.

The picture of the modular mimic display (Figure 1) shows the basic structure of the PCM. It is a two-computer system that is expanded in modular fashion by the addition of intelligent peripherals. This configuration was selected, on the one hand to achieve a strict separation of the individual levels of the OSI reference model, and on the other hand, to make a division of the

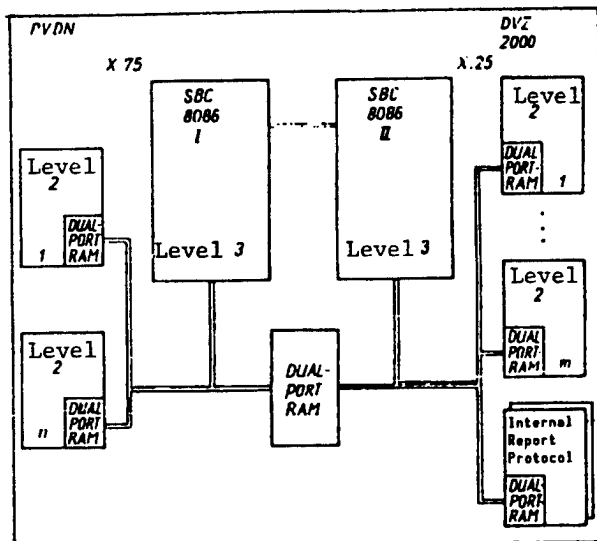

Figure 1. Principle Circuitry Plan for the Packet Communication Module

processing of the various protocols (X.25 in the direction of DPC or X.75 in the direction of the PVDNs in the GDR), possible.

For third-level processing of the protocols, there are two 16-bit OEM Computers SBC 8086 (single board computer 18086) based on the K 1810 WM 86, which communicate with the aid of a dual port memory¹. For operating and testing the hardware of the SBC 8086, an EPROM expansion card with two program-addressable free memory banks, as well as an indicator unit for bus signals were created. For communication in conjunction with software development or testing, the SBC 8086 has corresponding parallel and serial interfaces. In this way, interfacing with an office computer BC 5120.16, with a personal computer, MZ 80/B, as well as with a developmental system P 8000, including the appropriate software, can be realized. Thus, in addition to external methods of storage (such as floppy disks or magnetic tape), the keyboard and the screen of these computers can be used for interactive work with the SBC 8086.

For connecting the PCM to the DPC, or to the GDR's PVDN, there are universal link controllers (ULC's)—working independently of each other—that are based on a rapid U 880 system (clock frequency 4 MHz). In the direction of the DPC, 60 64-kbit/s channels (2 PCM-30 tracts) should be realized. The second level processing of the X.25 protocol of these channels is accomplished in its entirety in the ULC. In the direction of the PVDN, ULC's are also used to process the second level of the procedure X.75. The packets, which were freed of the level 2 operational information, are taken over with the aid of dual port-dual page storage systems, which are present on every ULC.

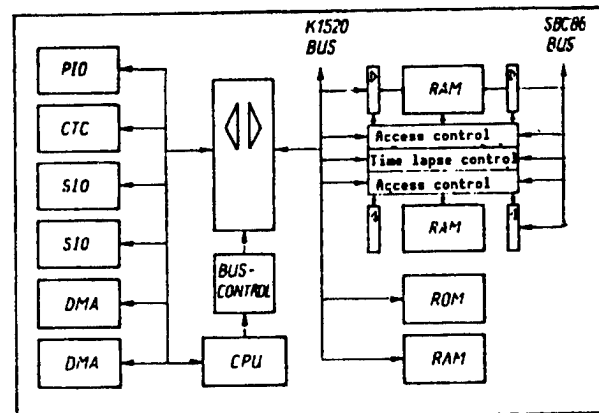

Figure 2. Universal Link Controller

The area in which the ULC is primarily used is working out all functions necessary for establishing, maintaining, and dismantling the connection. The flexible computer solution can also perform other functions, such as working out the internal report protocol or controlling the channel

commutator on the DPC. The ULC, whose principal switching plan is shown in Figure 2, contains the following component groups:

- CPU UA880, to the unbuffered bus of which, all peripheral interception circuits are connected (2 SIO, 2 DMA, CTC, PIO)
- Bus driver, including corresponding control switches
- Memory block with RAM or EPROM circuits (there are 7 sockets for EPROMs U2716/U2732 or RAMs U6116; in addition, external memory modules from the ULC can be used via the K 1520 bus).

A dual port/dual page memory having the following characteristics is used to tie into the SBC 8086:

- Potential use of the ULC as a passive memory card in K 1520 systems as a link to an SBC 8086;
- Block commands can also be used on the part of the SBC 8086;
- The dual page principle makes a separation of the data writing and data reading functions possible. As a result, fewer instances of internal blocking occur, and data transfer occurs more rapidly.

Thus, instances of extended access in conflicts in worst-case scenarios—e.g. block commands on the part of both processors—occur only 7 percent of the time; 10 percent in the case of the SBC 8086. For both 4-kbyte storage sections in each direction, 2 access controls and a shared time-lapse control have been developed. The dual port/dual page memory also causes the adaptation of the 8-bit data base of the UA 880 to the 16-bit data bus of the SBC 8086. The resulting word access on the part of the SBC

8086 doubles the transfer rate. In this way, the packet transfer from the ULC to the dual port coupling memory and vice versa requires only 6 percent of the processing capacity of an SBC 8086.

The ULC's software includes the operating system (initializing the peripherals, memory test, among others), as well as the program module for level 2 processing. The latter is present in assembler language and in CHILL. Beyond that, it is possible to implement special software, e.g. language packets, or alternative software, e.g. channel commutator control software.

As a result of its flexible hardware and software structure, the universal link control can be adapted to a wide variety of applications. The structural identity of all controllers makes a dynamic, program-directed change of its function possible, which results in a meaningful increase of the reliability of the PKM. To increase effectiveness in programming levels 2 and 3 of protocols X.25 or X.75, higher program languages (particularly CHILL) are being used when possible. Corresponding SDL graphs, among other things, serve this purpose. An office computer, BC 5120.16 and a P8000 with the operating systems UDOS and WEGA serve as software development systems. Time-critical or hardware-related software modules are realized in U880 or 8086 assemblers.

Bibliography

1. Kolloschie, H., Rommeck, S.: "Use of 16-bit Microcomputers in a Packet Communication Module." Dresden Polytechnic Institute, Department of Information Technology, 1989.

INDIA

Private Satellite Network Planned for Mid-1989 *55500067 Calcutta THE TELEGRAPH in English* 8 Mar 89 p 8

[Text] Calcutta, March 7: Vikrant, the private satellite network for across the city communication through computer is likely to be launched by the middle of 1989. The efforts of the department of telecommunication, (Dot) to launch the network sometime in September last year failed due to certain technical problem. It was now almost certain that it would become operational by June or July, according to Mr Kapil Jain, business development manager of DCM Data Products.

The company, Mr Jain said, has accordingly prepared itself to take full advantage of the network and launched DCM Zeus Tower Line, series a fourth generation super mini computer with 20 mega hertz speed. The advance level computer with 2,000 megabyte storage capacity and capable of handling 32 terminals, was developed and designed entirely by the research and development wing of DCM Data Products, he said.

These units would easily replace the earlier generation computers of eight to 16 beats with little extra cost but would provide a number of extra services to the customers. DCM Data Products, one of the early entrants in computer manufacture and marketing in the country, would make efforts for replacement of the earlier generation units with the Zeus Tower Line computers as the new ones would provide far wider services at very little extra costs, Mr Jain said.

One of the primary selling points of the new computer was that they would provide wide area networking facility for the customers to link across the cities whenever the Vikram public switched data network of the DoT became operational, he said.

The company which grossed a turnover of Rs 25 crores last year has decided to consolidate its position in the current year as a lot of technological developments have been taking place in the field of computer manufacture and marketing. The primary job of the company in the current year would be to convince the existing customers to switch over to the latest generation units as expenditure on software would remain almost the same with much larger benefits.

Mr Jain said that the company has obtained a Rs 6-crore order from the Indian Railways for micro processor based axle counters developed by the R&D wing of the DCM Data Products, for modernisation of signalling system. The railway equipment group of the R&D wing along with IIT, Delhi, was now working for an advanced product such as Radio Block Interface, (RBI), for ensuring fault tolerant signalling systems.

DCM Data Products, which represents Control Data Corporation of the U.S. for mainframe and super computers in India, he said, was hopeful of obtaining the U.S. government's clearance for installation of the first advance super computer at IIT, Kanpur.

INSAT-II Test Spacecraft To Launch Mid-1990 *BK1604091689 Delhi Domestic Service in English* 0830 GMT 16 Apr 89

[Text] The first INSAT-II test spacecraft will be ready for launch by the middle of next year. The second test spacecraft in the series will be ready in June 1991.

This will be followed by three operational satellites which will replace the INSAT-I series, the last of which—INSAT-ID—is scheduled for launch next month.

Minister Announces TV Coverage Expansion Plan *BK1504075989 Delhi Domestic Service in English* 0730 GMT 15 Apr 89

[Text] Doordarshan services will be expanded to cover 83 percent of the population. This was stated by the union minister for information and broadcasting, Mr H.K.L.Bhagat, at Sangli in Maharashtra. He was recommissioning the Doordarshan relay center there.

Mr Bhagat said the number of transmitters would be increased soon to 423 from the present 335.

Tata Institute Radiotelescope in Soviet Project *55500066 Madras THE HINDU in English* 11 Mar 89 p 10

[Text] Bombay, March 10. The 500m-long cylindrical steerable Ooty radio telescope (ORT) of the Tata Institute of Fundamental Research (TIFR), which is beginning its 20th successful year of operation, will be one of the ground radio telescopes for a unique Soviet space-based radio astronomy project, called "radiostron". This was stated by Dr Anantakrishnan of TIFR's radio astronomy group on March 8 at a seminar.

"Radioastron" will be an orbiting antenna which will dock as a module in 1991-92 to the now orbiting 'Mir', the Soviet space station. The project plans to undertake the so-called very large baseline array (VLBA) interferometry experiment in association with the most powerful ground stations. The ORT will be one of these in the metre wavelength.

The ORT is designed to receive celestial radio signals in the 325-328 megahertz frequency range which is equivalent to about 0.92 metre wavelength. The "radiostron" antenna will operate at frequencies of 22.5 gigahertz 1.6 gigahertz and 327 megahertz with an apogee of 7,700 km and perigee of 2,000 km it will have a highly eccentric orbit.

Finer resolutions possible: By going to interferometric techniques which is essentially based on correlation between coherently received radio signals at widely separated antennae, radio astronomy has been able to achieve angular resolutions of fractions of an arc second compared to a second of arc resolution in terrestrial optical telescopes and one-tenth of a second of arc resolution envisaged in the Hubble space telescope which has been grounded for want of a U.S. space shuttle.

The technique which forms the basis of radio interferometry is the so-called very large baseline interferometry (VLBI), where the angular resolution achieved is inversely proportional to the distance between antennae and directly proportional to the wavelength of radio waves.

To achieve a fine (i.e., small angle) resolution large 'baseline' distances and high frequencies (short wavelengths) are chosen. Using this principle the so-called very large array (VLA) telescope assembly, with 27 antennae of 25m diameter each and movable over 21 km arms of a Y-shaped array, at Jodrell Bank, U.S. has already achieved fractions of a second of arc angular resolution.

The new concept of VLBA is being implemented with 10 precision antennae, each of 25m diameter located at Puerto Rico, the U.S. and Hawaii. The VLBA will operate in the frequency range 330 MHz to 43 GHz and is aimed at achieving angular resolutions of hundredths to thousandths of an arc second.

Entire range: While this will be a terrestrial VLBA, the "radioastron" will be a space-cumterrestrial one, thus allowing a complete coverage of the entire possible range, baseline distances both in the East-West and North-South directions.

The Oltoo had proposed a similar one, called "Quasat", but this is as good as dead as it is not being funded. The Indian radioastronomers will, therefore, be taking part in a really frontline experiment.

Though the ORT operates at larger wavelengths, its continuous tracking capability for 10 hours, high steerability and very large signal to noise ration, combined with the fact that this is the only radio telescope in this part of the world so that large experiment baseline distances become possible, render it an ideal choice for it. It is also being augmented with improved low noise amplifiers at each one of its parabolic antennae to increase signal outputs.

Constraint: A recent finding with the ORT however has posed a constraint on high resolutions that can be achieved at metre wavelengths. This is the discovery of the so-called "phase patch" moving across the sky at 400 km per second. This has been correlated to the scattering

of radio waves by the solar flare. the "radioastron" project will be able to determine whether the limitation is severe in attaining a resolution of thousandths of an arc second.

As and when the giant metre wave radio telescope (GMRT) comes up—it is also scheduled for 1991-92—near Pune it will also be part of the Radioastron project.

Meanwhile the radio astronomers are looking forward to the approval of the Indo-Soviet terrestrial VLBI project in the centimetre wavelength region using a 70m telescope to be obtained from the USSR and installed in the Deccan region.

This telescope, together with similar telescopes at Ussisursk and Ephpatoria regions of the USSR will form the triangular array for high resolution radio astronomy work on pulsar motion measurement. This 70m telescope can also be part of the "radioastron" project in the centimetre wavelength.

The 70m interferometric array will also be able to perform an interesting plate tectonics measurement. The VLBI technique can detect plate movements to an accuracy of a cm. In plate tectonic studies, the measurement of the rate of slippage and convergence between the Indo-Australian and Eurasian plates has shown a tremendous amount of uncertainty.

Whether this movement is 6.8 cm a year or 2.8 cm a year is yet to be resolved. This has a bearing on our understanding of the rising of the Himalayas which is believed to be about four to five cm a year. This Ussisursk-Ephpatoria-Deccan VLBA may help resolve this puzzle.

Minister on Satellite Facilities, U.S. Computer
BK2404093189 Delhi Domestic Service in
English 0830 GMT 24 Apr 89

[Text] India is trying to secure more satellite facilities for telecommunication and television programs. It has sought 11 transponders on lease from Intelsat for the purpose. Giving this information in the Lok Sabha today, the minister of state for science and technology, Mr K.R. Narayanan, said an orbital slot has already been assigned for INSAT-1B and INSAT-1D which are to be launched shortly.

Mr Narayanan also justified the acquisition of a U.S. supercomputer for medium-range weather forecasting. He explained that over 1 trillion mathematical calculations are involved to predict weather for 3 to 10 days in advance. This can be done only through a supercomputer, he added.

IRAN

New Ground Satellite Station Established

*NC0705063189 Tehran Domestic Service
in Persian 0430 GMT 7 May 89*

[Text] Behabad District in Yazd, with a population of 10,000, can now view the programs on Network 2 of the Vision of the Islamic Republic of Iran. The Central News Unit reports that thanks to the efforts of the unit of television transmitters of Yazd, and thanks to a ground satellite station and a 10-watt transmitter, the Behabad residents can view Network 2 programs of the Vision of the Islamic Republic of Iran on Channel 8.

The report also states that with the operation of the Vision's Network 2 transmitter in Behabad, there are now six ground satellite transmitters in Yazd Province.

OMAN

Minister Discusses Expansion of Telecommunication Services

55004516 Muscat AL-WATAN in Arabic 27 Feb 89 p 4

[Article by Mu'min Khalifah]

[Text] AL-WATAN has learned that the General Telecommunications Organization will complete the second stage of expanding the telephone system on the coast of al-Batinah this year. This stage, which covers about 100 cities and villages in the area on the coast of al-Batinah, will provide 9,350 telephone lines to cities and villages in that area.

Work will also be completed this year on a project to expand the telephone system in Salalah.

His Excellency Ahmad ibn Suwaydan al-Balushi, minister of posts, telegraphs and telephones told AL-WATAN that the ministry was going ahead with its plans to extend telephone service to various areas of the sultanate. He said that achievements never stop and that eminent instructions from His Royal Highness Sultan Qabus ibn Sa'id the great demand that all areas have access to postal and telephone services and that no distinction or preference be given to one area over another.

His excellency the minister of posts, telegraphs, and telephones said, "Comparing telecommunications before and after the age of the blessed advancement will be astonishing by all standards, especially if we know that before the blessed advancement the sultanate had no more than 500 telephone lines and 14 telex lines. This is just one example and not an exhaustive description of the situation. Postal and telecommunications services in various areas of the country have most certainly been developed in a major way."

His excellency added, "In compliance with the eminent instructions from His Highness the Great Sultan, we started working tirelessly and continuously after the blessed advancement to make postal and telecommunications services accessible to all parts of the country. We actually accomplished what we wanted to accomplish, and now the sultanate has a communications system the efficiency, precision, and speed of which can match the efficiency, precision and speed of any comparable system worldwide. The figures testify to that and confirm it."

His excellency indicated that maximum telephone capacity in the sultanate last year reached 121,464 telephone lines, whereas total operating connections exceeded 74,000 lines.

His Excellency Ahmad ibn Suwaydan al-Balushi, minister of the posts, telegraphs and telephones said, "Our plans seek to be inclusive. We do not concentrate exclusively on Muscat and major cities, but we look at the sultanate as a whole. We recently completed two major projects. The first, a project for the coast of al-Batinah and Qurayyat, provides 16,680 telephone lines. The rural communications expansion project provides 27,712 lines. Residents of these areas now have telephone services."

His excellency said, "We introduced the mobile telephone system in 1985, and almost all areas of the sultanate are now covered by that system whose switchboard has the capacity for 4,500 mobile telephone lines. That capacity may be increased. Citizens' demand for this service has been growing, especially after its tariff was reduced in May of last year."

His excellency added, "The ministry has installed public telephones in various areas of the sultanate to make things easy for citizens and to provide telephone services to citizens everywhere around the clock."

His excellency said, "In 1970 the sultanate had only one earth station. Now we have a collection of earth stations for international communications that operate via international and Arab satellites. It is now possible for any subscriber to communicate directly with most countries of the world."

His excellency indicated that communication services were not limited to telephones. "The sultanate has telex and telegraph services, the sharing of information through computers, in addition to other services which are offered by the General Telecommunications Organization."

His excellency said that in 1988 the telex switchboard had a capacity for 3,052 lines. By comparison, there were only 14 telex lines in 1970.

Telegraph services have been made available throughout the country. Previously, there was only one telegraph office in Muscat.

Speaking of the meetings of the Arab Organization for Space Communications [ARABSAT], His Excellency Ahmad ibn Suwaydan al-Balushi said, "The sultanate was one of the first Arab countries to build its earth station so that it would work with the Arab satellite, Arabsat."

His excellency indicated that the sultanate was paying the Arab Organization for Space Communications, ARABSAT, about 309,000 Omani riyals annually for using the satellite locally.

QATAR

Telecommunications Grid Reviewed

55004517 Doha AL-ARAB in Arabic 22 Feb 89 p 6

[Article: "118,000 Telephone Lines To Cover All Areas; Arabsat Links Qatar to Advanced Communications System; Doha Airport Received 9,501 Airplanes Last Year"]

[Excerpts] [Passage omitted]

The state of Qatar has a modern communications system that meets the country's needs and covers a variety of vital areas: it serves commercial traffic, and it stimulates economic activities as well as the movement of capital.

Qatar's distinguished location halfway on the coast of the Arabian Gulf and its role as an important link in the system of worldwide communications between Europe and Asia have helped to focus attention on the country's communications system, which has in fact become one of the state's chief concerns. The Ministry of Transportation and Communications is trying to implement several projects to strengthen the communications system. It is trying to increase and expand Qatar's connections with the world by land, sea and air, and it is modernizing and expanding telecommunications services. The ministry is always trying to improve the efficiency of these services. It is trying to develop services at land ports, airports and meteorological stations, and it is also trying to develop postal services.

The Local Communications System

Most of the state of Qatar is covered by a telecommunications system. The Telecommunications Administration, which is going through with its development plans for the telephone communications sector, is providing this vital service to the different areas of the state. At the present time the country is served by an integrated system of telephone communications whose capacity is more than 118,000 lines. This system covers all areas of the state.

There is a system of modern devices for international communications, which is being expanded continuously. The number of its operating circuits has been increased, and the number of directions and countries which can be reached directly from Qatar by telephone and telex lines has also been increased.

Qatar has a high quality, direct communications system that is made possible by three earth stations for space communications—Doha 1, Doha 2 and Arabsat. Besides, there are microwave lines between Qatar and the Kingdom of Saudi Arabia. The underwater cable which connects Qatar, the United Arab Emirates and the state of Bahrain with a high quality, less costly, direct communications system with a capacity for 1,200 telephone circuits. Qatar's most important achievements in the fields of communications and transportation are all related to the use of modern means which have been used in linking Qatar with the countries of the world. Qatar now has direct communications with approximately 165 countries of the world.

The Coastal Station for Telecommunications and Off-Shore Communications

The coastal telecommunications station was built to provide an advanced communications system for vessels at sea as well as citizens. At its present location the station is Qatar's window on the world's seas and oceans. The station operates the most modern communications equipment, and it uses advanced machines and state-of-the-art technology to cover all telephone, wire, and telex communications services to different vessels sailing on the high seas and oceans.

Earth Stations for Communications Using the Satellite, Arabsat

Using the satellite, Arabsat, the earth station for space communications has joined other earth stations operating with satellites over the Indian Ocean and the Atlantic Ocean to form something like an integrated space communications system. Qatar was thus linked with Arab countries in an advanced system for transmitting telephone, wireless and telex communications. The system also allows Qatar to share television programs and information with most Arab countries. There are now special circuits for such communications with the United Arab Emirates, the Sultanate of Oman, Kuwait, Jordan, Tunisia, Yemen, and other fraternal countries.

Excellent Postal Services

To safeguard and develop postal services the Postal Administration utilizes the most modern means and systems which are used in the advanced countries of the world. At the present time letters are collected and sorted by machines. More than 25 postal offices have been set up in residential areas and major hotels. These offices are distributed among the suburbs of Doha and the country's other cities.

The Postal Administration made significant progress as work began on the Central Postal Building for the Arabian Gulf. With the modern devices, the modern means and the modern technology in that building, the Postal Administration is operating and offering postal services at a high level of efficiency. This is because work

in this huge modern complex is done by computer and automatic sorting machines.

Gulf Airways

[passage omitted]The expansion of international flights to and from Doha was accompanied by expansions at Doha International Airport, which is located 3 miles from the center of the capital. The airport has a runway that is 4,572 meters long, and its advanced navigational equipment and computerized meteorological system provide a high level of safety for automatic landings on the runways.

According to the development plan the runway and secondary strips were recently reinforced, and the areas where airplanes are parked were enlarged. New buildings were added as terminals for arriving and departing passengers. Recent statistics show that 9,501 airplanes landed in Doha Airport in 1988. The number of arriving passengers at the airport was 488,511, and the number of departing passengers was approximately 473,387.

Sea Ports

Because of their distinguished geographic location Qatar's sea ports are the country's principal artery for foreign trade. That is why special attention is being given to developing, expanding, and modernizing Qatar's ports and their equipment. The ports of Doha, Musay'id and al-Ruways are considered the country's most important sea ports. While the port of Musay'id is used by incoming tankers and very large vessels that carry raw materials to Qatar, it is also used to export petroleum and industrial products. The port of Doha receives shipments and goods that have to do with the commercial sector.

Electricity and Water Facilities

The Ministry of Electricity and Water has made significant achievements in its development of these two facilities, especially after the Electricity and Water administrations were merged into one. The country receives electrical power from three main power stations whose total capacity is approximately 836 megawatts. These are the Ra's Abu 'Abbud, the al-'Arish, and the Ra's Abu Fintas power stations. The latter, which is the largest power station in the country, runs on natural gas. Sea water is desalinated at that station by using the heat which is lost in the process of generating electricity.

With regard to the new power generating and water desalination plant which is to be built in al-Wasil, officials are waiting for the green light to start implementing the first phase of this project which includes four steam-powered generators and eight water desalination units. Total production capacity for this plant when completed will amount to 1,500 megawatts of electricity and 100 million gallons of water a day.

With regard to the water sector, plans are still underway to develop the filtering plants. Consequently, the Ra's Abu 'Abbud station is now producing 8 million gallons of water a day; the Ra's Abu Fintas station is producing 38 million gallons of water. The al-Wasil water plant will have a production capacity of 100 million gallons of potable water a day. Water storage capacity will be 200 million gallons of potable water after construction and maintenance work is completed on the storage tanks of al-Gharafah, the Arabian Gulf, Salwa Road, al-Shamal City and al-Khur.

UNITED ARAB EMIRATES

Abu Dhabi to Have New Meteorological Satellite Receiving Station

55004521 *Dubayy GULF NEWS in English*
24 Mar 89 p 2

[Article by Muhammad 'Uthman]

[Text] Abu Dhabi—The meteorological station of the Abu Dhabi department of Civil Aviation will get a new highly sophisticated weather satellite receiving station this year, as part of the department's plans to expand the observational network.

This was revealed in a speech delivered by Shaykh Hamdan Ibn-Mubarak, the Undersecretary of the department, on the occasion of World Meteorological Day. The speech was delivered during a special function held yesterday at Abu Dhabi International Airport.

In the speech, read out on his behalf by Sultan Ibn-Ghalum Al Hamili, the advisor at the department, he said that the Civil Aviation department currently employs a staff of 60 meteorological forecasters and assistants with well equipped observatories, an upper-air sounding station, satellite receivers and a computerised statistical data-base.

He said that they also provide technical assistance to many other departments such as Mina Zayid and UAE University together with many investigations undertaken for the private sector.

Shaykh Hamdan stressed the importance of expanding the observatory network due to the increasing complexity and volume of air traffic worldwide.

He said that today the global observing system comprises of 9,500 surface, 770 upper-air and 600 radar observing stations together with reports from 7,000 ships, 200 drifting buoys and aircraft and weather satellites.

Later journalists attending the special function were taken to observe the launch and tracking radiosonde balloon which is launched every six hours. The balloon carries an instrument package which measures the pressure, temperature and humidity through the atmosphere

up to 70,000 ft. levels. A small radio transmitter sends the information back where it is decoded. A special radar tracks the balloon and computers calculate the wind speeds and direction at various levels.

Explaining the various stages of the operation, Roger F. Williams, senior meteorological officer, said that standard meteorological instruments measure atmospheric conditions. Observations are carried out every 30 minutes and these are passed on to the main Met office and to air traffic control which passes them to both in and outbound aircraft to facilitate safe arrivals and departures. The same observations are also passed through the communications centre to other Gulf countries and into the global meteorological network.

The communications centre regularly receives the meteorological data in the form of surface and upper air observations in a coded form from all the Gulf stations and regional centres. These include Europe, North Africa, the Indian Subcontinent and South East Asia which are all linked to the global Met telecommunications network. Further information is received from London, Moscow and New Delhi.

Williams said that the main Met office is where the data is received on the telecommunications network. The data is decoded and plotted into surface and upper air charts. These charts provide detailed information on the weather conditions over a wide area. The forecaster then analyses these charts to formulate a weather forecast.

EUROPEAN AFFAIRS

TAT-8: Fiber Optics Crosses Atlantic
*80190362a Paris MESSAGES in French No 381,
Dec 88-Jan 89 pp 19-24*

[Article by Denise Frilloux]

[Text] France, Great Britain and the United States will henceforth be connected by the first undersea transatlantic cable made of optical fiber. With a length of 6,751 km, TAT-8, which has in fact been in operation since December 15 of last year, as of 1989 will handle 30 percent of the telephone communications to North America. It will be completed in 1991 by laying a more powerful cable, the TAT-9.

The first transatlantic undersea fiber optic cable, the TAT-8, was put in service on December 15 between the United States, France and Great Britain. This optical cable with a length of 6,751 km running below the ocean at a depth of 4,000 m then beats the record set in July 1987 by the optical undersea cable connecting Marseille and Ajaccio, the "Continent Corse III," 390 km. The American portion of TAT-8, placed by the AT&T, made up of three fiber pairs, ¹ one of them a replacement, i.e. 7,680 circuits capable of simultaneously running 40,000 telephone communications, starts in Tukerton, New Jersey, to end 5,872 km from the American coast in the French and English areas.

The French constituent was implemented by Submarcom, a common subsidiary of CIT-Alcatel and Cables de Lyon. It consists of two pairs (one for substitution) of monomode fibers² in a cable with a 25 mm diameter on 360 km length. This section starts in Penmarch located on the Southern tip of Brittany. The English portion, also made up of two fiber pairs of 519 km length, comes from Widemouth in Cornwall.

The cabling vessel "Vercors" of the cabling fleet of France Cables et Radio, a subsidiary of France Telecom,³ has laid the French portion and implemented the ocean connection of the three sections. They were buried on 200 km of the continental platform (low-tide area), which borders on the Breton littoral. This so-called mudding operation, which has taken close to one and a half months, is to protect the cable against outside attacks, especially in fishing areas, where trawlers scrape the sea bottom with their nets. The optical core of the fiber itself is protected against water pressure by a steel wire arch. The French optical cable is equally designed to prevent any fiber stretch: they are lodged with sufficient length allowance in helicoidal grooves, within which they can move as a function of cable stretch. In addition, sealing plugs at regular intervals prevent water propagation during a cable rupture.

Even though placing an undersea optical cable is a difficult operation—the cable might curl—the fiber optic cable will permanently take the place of the coaxial cable.

"By its total insensitivity to the electromagnetic field, fiber optics assures an excellent transmission quality. In addition, an undersea fiber optic cable needs a repeater for signal regeneration only every 50 km, and soon only every 100 km, as compared to 10 km for the coaxial cable." This is emphasized by Gerard Dupin from the undersea telecommunications service at the administration of external networks of France Telecom.

TAT-8 30 Percent of Communications With North America

If the service life for a fiber optic cable or a coaxial cable is the same—twenty-five years—the first is two or three times thinner and lighter, about 620 g per meter.

However, first of all optical fiber is the ideal support for digital transmissions, whether they be on the ground or under water. The TAT-8 can therefore carry both sound and data, or images. The users of the TAT-8, whose services are provided commercially by France Cables et Radio,⁴ are therefore chiefly telecommunications operators for telephone communications between Europe and North America, or multinational banks and companies for data transfer. As of 1989, TAT-8 will handle 30 percent of the telephone by digital satellite and 37 percent by cable).

After placement of the second transatlantic undersea fiber optic cable in 1991, the TAT-9, half of the telephone communications from France to North America will be handled by undersea fiber optic cable.

Two Links in a Worldwide Network

The TAT-9, twice as muscular as its big brother with 15,360 circuits, will separate into two branches on the American side: one to Tukerton, the other to Pennant Point in Canada. On the European side, TAT-9 will have three branches: the first to St Hilaire-de-Riez in Southern Brittany, the second towards Conil in the South of Spain, and the third to Goonhilly in Southern England.

In reality TAT-8 and TAT-9 are only two links in the vast worldwide network of undersea fiber optic cables being placed. France Telecom participates in several international projects: in the English Channel with laying of the France-Great Britain cable next year between St Valery and Eastbourne, 150 km of fibers without repeater; in the Mediterranean with the 1990 placement of "Emos 1," which will extend the "Continent Corse III" cable to Sardinia, Sicilia, Greece, Turkey, and Israel; in the Atlantic with the 1991 laying of the France-Portugal cable "Tagide II" between Penmarch and Lisbon.

Footnotes

1. Fiber optic cables are always laid in pairs: one fiber is needed in each communication direction.

2. In a monomode fiber, one single beam of light moves parallel to the fiber axis, providing a very high pass band, up to tens of Gigahertz. In a multimode fiber, the light beam propagates along a multitude of paths by reflecting on the fiber walls. The pass band does not exceed one thousand Megahertz.

3. This fleet has three vessels: the "Vercors" specializing in laying cables, the "Leon Thevenin," and the "Raymond Croze," both established specifically for maintenance in the Atlantic and the Mediterranean.

4. France Cables et Radio - 124, Rue Reaumur, 75002 Paris, Tel. (1) 42 21 71 71.

EC Official Assesses Telecom Reforms

AN890124 Chichester INTERNATIONAL
TELECOMMUNICATIONS INTELLIGENCE
in English 24 Mar 89 pp 1-2

[Unattributed article: "European Administrations Show Signs of Unity, as Trade Balance Comes Under Scrutiny"]

[Text] European telecommunications trade with the rest of the world "will need careful attention" over the next few years, according to Dr H. Ungerer, head of division of the Telecommunications Policy Directorate of the CEC [EC Commission]. He says that while the Community continued to enjoy an overall telecommunications equipment trade surplus of ECU 1,029 million in 1988, "this picture is flawed by deficits of ECU 944 million with Japan and ECU 494 million with the U.S."

He believes that these statistics indicate that "trade relations with the United States in this area will continue to require constant attention." In the case of Japan the situation is more serious. "The global trade deficit of the Community with Japan in telecommunications equipment remains at dangerous levels," he said, adding that the figures demonstrated "an unsound imbalance in the opening of markets."

As an example he cites imports of facsimile terminals from Japan into the Community. During the twelve months to June 1988 these totalled ECU 267 million, 88 percent higher than in the previous year.

"But," he claims, "Europe is closing its ranks on telecommunications" and member states are responding to Commission calls for "greater solidarity with regard to the major international questions on telecommunications." The final results of the International Telecommunications Union World Administrative Telegraph and Telephone Conference (WATTC), held in Australia in December 1988, have shown the EC member states

now recognise their basic common interests. This was the first time that the Community took part in an ITU [International telecommunications Union] conference as a coherent entity. "All twelve states signed the final acts of the new ITU regulations and made a joint declaration that they will apply the regulations in accordance with their obligations under the EEC Treaty," he said.

He admits, though, that such unity was not lightly achieved, and that the preparatory work before the conference was "a difficult process."

The next opportunity for the EEC to flex its newly found communal muscles will be in the current GATT round, Ungerer says. These international trade talks will present a "further test case, with progress up to now under review." He adds that cooperation with the EFTA countries—Austria, Finland, Norway, Sweden and Switzerland—"will have to be intensified in the context of an overall evolving relationship."

All this adds up to an endorsement of the Commission's policy for pan-European telecommunications as set out in the "Green Paper" on telecommunications, Ungerer maintains. Less than two years after its publication in June 1987, the "various national reform projects for the sector in individual European countries have expanded into a truly Europe-wide reform movement."

An important milestone was the passing of a resolution on Posts and Telecommunications by the European Parliament on December 14th, 1988. Other key developments in the process of regulating Europe's traditionally monopolistic telecommunications administrations include the change in status of the Netherlands PTT on January 1st, 1989, on schedule; Spain's adoption of its new telecommunications law and "its movement towards implementation"; "important steps by France towards the liberalisation of value-added services and mobile communications"; and "major steps in the direction of structural reform" which Ungerer says have been taken by Belgium, Italy and Portugal. The UK, he points out, has taken further steps towards total liberalisation with the latest "move on satellite communications, made in 1988."

But while the general principles of the Green Paper appear to have been generally accepted, and most countries are setting in motion regulatory changes, there are problems. In particular, the EEC directive on the opening up of EEC-wide markets for terminal equipment to competition is being challenged by the French, Belgian, Italian and German Governments.

The directive was issued on May 16th, 1988 and, according to Dr Ungerer, was based on the EEC's "mandate under competition law, based on Article 90 of the Treaty of Rome." However, currently the directive is "subject

to an appeal in the European Court of Justice for partial withdrawal." The action was started by the French Government and subsequently joined by the three other governments.

Ungerer, however, does not believe that this will detract from progress towards the ultimate goal. "There is no disagreement on the substance of the directive's aim to open up the terminal equipment market to increased competition," he explains. The appeal concerns only the legal technicalities of whether Article 90 (3) or Article 100a is the appropriate Treaty basis for the actions proposed."

He is, nevertheless, quick to point out that the terminal directive "remains in force" and that the appeal does not suspend its application.

Now a critical period of decision-making is ahead, Ungerer says. "A major issue at EC level will without doubt be the discussion of the approach to the common market on telecommunications services; another will be the opening of procurement by telecommunications administrations. The implementation of full mutual recognition of type approvals will soon reach a critical stage; reshaping of standards will have to prove itself in real operations; and the future development of satellite communications in Europe is an issue which can no longer be dodged."

BELGIUM

Alcatel Plans Digital Exchange Contract With USSR

Advanced Negotiations

*AN890082 Groot-Bijgaarden DE STANDAARD
in Dutch 8 Feb 89 pp 1, 8*

[Article signed S.M., DE STANDAARD correspondent in Moscow: Bell Holding Advanced Negotiations on Joint Venture in USSR—40 Billion Belgian Franc Contract"]

[Text] The Antwerp telecommunications company Alcatel-Bell Telephone is currently negotiating the establishment of a telecommunications joint venture in the USSR. The discussions, which began 18 months ago, have reached an advanced phase. Mr Morel, manager of external relations at Bell, is quite confident that the contract will be signed this year. The joint venture involves the establishment of a telecommunications firm in Leningrad for an initial period of 20 years and is worth 40 billion Belgian francs.

While on a trade mission to Moscow, Minister of Economic Affairs Willy Claes and Minister of Foreign Trade Robert Urbain explained to the Soviet authorities the importance of the Alcatel-Bell Telephone venture to the Belgian Government. The Soviets are obviously interested in such a venture but still have questions regarding

funding procedures. The parties involved are investigating various funding methods; expectations are high that some kind of an agreement can be reached, and that Bell will be awarded the contract.

Under the terms of the contract, Bell will own 60 percent of the Leningrad telecommunications company while the USSR will hold the remaining 40 percent. Production is scheduled to begin in 1991-1992 and the plant will have a production capacity of 1.5 million lines a year when fully operational. The 20-year contract further stipulates that after 8 years Bell will set up a new joint venture in the USSR for the manufacture of microchips. The overall value of this contract is about 40 billion Belgian francs.

One condition put forward by Bell, however, requires the USSR to purchase about 250,000 lines in Belgium in the initial phase. This represents approximately 2.5 billion Belgian francs. Furthermore, Bell expects the Leningrad company to be the first in a series of Eastern bloc telecommunications factories.

The sale of Bell's "System 12" digital telephone exchanges to the USSR is no longer a problem since COCOM, which controls the sale of high-technology products to the Eastern bloc, gave the go-ahead on 15 September of last year. The matter is slightly more complicated for the technology transfer entailed by the joint venture, but Bell expects a solution to be found. Moreover, the Belgian telecommunications firm has agreed to train Soviet technicians in maintenance of the exchange, beginning this year.

Some of Bell's competitors are also interested in this contract, but the Belgian company is confident it has the best credentials: The Soviets hope to emulate the success of the Bell factory in Shanghai.

The agreement signed in Moscow on 2 February between Belgium and the USSR on the mutual protection of investments is particularly important to Bell. It obviously lessens the risk premium the company will have to pay to finance the project.

Belgians Approve First Phase

*AN890122 Chichester INTERNATIONAL
TELECOMMUNICATIONS INTELLIGENCE
in English 10 Mar 89 p 6*

[Unattributed report: "Alcatel Close to Signing Digital Exchange"]

[Text] Alcatel, Europe's largest telecommunications manufacturer, is set to make a significant move in the transfer of high-technology goods to the Eastern bloc following the relaxation of some trade restrictions set out by the COCOM organisation, which limits the export of technical equipment to the USSR.

Under a proposed two-phase contract, Bell Telephone Manufacturing (BTM), Alcatel's Belgian subsidiary, will supply 250,000 lines of its System 12 digital exchanges as part of a programme to develop the USSR's telecommunications infrastructure. The second stage involves the formation of a joint venture between BTM and the Soviet company Krashna Zaraya to set up an exchange assembly plant near Leningrad with a capacity to produce up to 1.5 million lines a year. The deal is expected to be worth more than \$1 billion in sales over the next 10 years.

The Belgian government has approved the first phase and is awaiting advice from COCOM regarding the assembly plant.

In the past, leading European suppliers to the USSR of analogue and digital switching equipment have included Alcatel, Sweden's Ericsson, Nokia of Finland, Turkey's Teletas, the UK's GPT, Siemens of West Germany, Italy's Italtel, and the Dutch AT&T Network Systems International (formerly APT).

In 1986 an estimated \$1,537 million was spent in the USSR on local and toll switching and \$1,781 million on rural communications systems. In 1990 expenditure in these sectors is expected to be more than \$3,000 million and \$1,800 million respectively.

CANADA

Ruling on Telecommunications Regulation Reported Near

55200025 Toronto *THE GLOBE AND MAIL*
in English 21 Mar 89 p B5

[Article by Angela Barnes]

[Text] The direction of Canada's \$10-billion telecommunications industry rides on a decision by the country's highest court on a fundamental question: which level of government is responsible for regulation of the industry?

The case pits CNCP Telecommunications of Toronto, an aggressive company that wants to offer a full range of national telecommunication services, including public long distance, against Alberta Government Telephones, a provincially owned phone company with a monopoly in Alberta that it wants to keep.

The case was argued before the Supreme Court of Canada in October, 1987, and a decision is expected within the next two months.

"It would not be exaggerating to call this a watershed decision," says Douglas Goss, manager of regulatory matters for Ontario's Ministry of Culture and Communications.

Regulation of telecommunications carriers is now split. The largest phone companies, such as Bell Canada and British Columbia Telephone Co., and carriers such as CNCP and Telesat Canada, answer to Ottawa, while the rest of the industry reports to provincial capitals. CNCP says the division is not conducive to rapid growth in the industry, or to its own growth.

But the Supreme Court decision must also be seen against the background of the long, drawn-out efforts to achieve a consensus on a national telecommunications policy.

The federal and provincial governments have been laboring at it so long that Hudson Janisch, a law professor at the University of Toronto, quips: "I always tell my students I did not have a grey hair in my beard when (the negotiations) started and now I look suspiciously like the Ayatollah."

What will come out of the talks that will inevitably follow the court decision is anybody's guess; it could range from a federal government takeover of provincially owned phone companies in Alberta, Saskatchewan and Manitoba, to Quebec getting some control over Bell Canada.

The long wait for a Supreme Court decision has caused speculation among members of the industry, with some suggesting the court is divided.

"If the court were united, I think we would have seen a decision before this," says Jim Dawson, senior director for telecommunications and electronics development in the Alberta government.

Others say the court may be searching for a compromise. As time passes, observers are less certain that the federal government will emerge the clear winner. But the odds still favor Ottawa.

"If I were a betting man, I would put it 90-to-10 in favor of the federal government," says Kenneth Engelhart, director of regulatory affairs for the Canadian Business Telecommunications Alliance, which represents business users of telecommunications. "But there is no such thing as a sure thing in constitutional law."

Even some provincial officials admit a judgment in Ottawa's favor is likely. "Based on what I have heard from the lawyers, it is my belief that the decision will come down clearly in favor of the feds," says Ontario's Mr. Goss.

Lower court rulings on this test case gave Ottawa jurisdiction over telecommunications. Madame Justice Barbara Reed of the Federal Court of Canada ruled in 1984 that a provincially owned and regulated telephone company like AFT is subject to federal jurisdiction. But she also said that AGT, because it is a provincial Crown corporation, it is not governed by federal statutes.

A year later, the Federal Court of Appeal ruled that the interprovincial activities of AGT were indivisible from the rest of its business and therefore all its activities were subject to federal regulation.

CNCP would like to see Ottawa hold on to the reins. Joseph Schmidt, CNCP's vice-president of regulatory and government affairs, says: "I suggest that a Supreme Court decision (in Ottawa's favor)...is one to be upheld, cherished and implemented, not to be cut up and parcelled out to perpetuate the splintered one that we have had for the last 100 years."

The company is only too well aware from recent CRTC decisions that Ottawa favors competition in telephone services more than most provinces. Even the commission's 1985 decision to reject CNCP's application to offer public long-distance services said the refusal arose from concerns about the viability of the planned service, not from a desire to maintain the phone companies' monopoly.

Few in the industry expect Ottawa to keep full jurisdiction over telecommunications. "I think some bureaucrats (in Ottawa) want to do it, but I do not think their political masters have the political will," says one government observer. He doubts whether such a move would be compatible with efforts at national reconciliation.

There is also a question of whether Ottawa would want to devote sufficient resources to the CRTC so it could regulate all the telecommunications companies on a day-to-day basis.

Instead, the federal government is expected to reopen the negotiations with the provinces on a national telecommunications policy. But the provinces may retain little bargaining power if the Supreme Court rules in Ottawa's favor.

"If AGT loses, there is no doubt that the federal government holds a lot of cards," admits Charles Feaver, senior telecommunications policy analyst for the Manitoba government.

Ottawa knows that the provinces will come to any talks bearing shopping lists. The western provinces that own phone companies want to retain at least some control. AGT, for example, is the largest single employer in Alberta, outside of the provincial government, and is used as an instrument of regional development.

Quebec's position is simple. "We just want to be treated the same as Alberta," says Jacques Pigeon, Quebec's deputy minister of communications. If Alberta retains control over AGT's interprovincial operations, then Quebec wants the same powers over Bell in Quebec.

Ontario, also served by Bell, does not want the same powers, "Ontario has not been pushing in any way for control over Bell," Mr. Goss says. "The current system is working well and we see no reason to change it."

It is also possible the provinces might get control over the phone companies' activities within provincial boundaries, but not their interprovincial operations. That raises the prospect of sharp increases in local service phone rates, particularly in provinces like Manitoba, which has not had a particularly buoyant economy, because local service rates are heavily subsidized by long-distance revenues.

Rogers Communications Announces \$1.1 Billion Program

55200028 Toronto *THE TORONTO STAR* in English
30 Mar 89 pp D1, D3

[Article by Adam Mayers]

[Text] Ted Rogers is embarking on a \$1.1 billion high-tech spending spree in an ambitious program that will carry his company into the 1990s.

Flush with \$1.64 billion (\$1.37 billion U.S.) from the sale of his U.S. cable television operations, Rogers is bringing the money home.

The president and controlling shareholder of Rogers Communications Inc. will plow the money into his cellular telephone company and domestic cable TV network. The cellular company will become the largest in the world and the cable system will be able to offer subscribers more channels and a better TV picture for a new generation of television sets.

Roughly 25 percent of Canadian homes with cable are served by Rogers.

"We are going to improve service in all aspects of our operations," Rogers told a news conference at Roy Thomson Hall yesterday. "It's great news; news that a Canadian company is taking \$1 billion from the U.S. and investing it in Canadian businesses for Canadians."

Longest network

The plans are partly in response to events that will unfold in the coming decade, but much of the cost will be borne within the next few years. The plans include:

\$600 million to be spent within 2-1/2 years on Cantel Inc. to increase its coverage coast to coast. That means that 75 percent of Canadians will be within its reach and, at 7,500 kilometres (4,600 miles), the system will be the longest connected cellular network in the world.

\$525 million on Rogers Cablesystems Inc. to install fibre optic cables, improve connect and disconnect service, increase channel choice, decrease customer inquiry waiting time, and prepare for the coming of high-definition television.

These sets—to be available in the early 1990s—will “revolutionize television,” said Rogers Cablesystems president Colin Watson. Although still in the development stage, the HDTV resolution is expected to be so crisp it will make current sets obsolete.

Last week, Rogers closed the sale of cable television operations in the U.S., a deal that brought in the \$1.37 billion (U.S.). That is \$100 million more than was expected.

Since then, analysts have been buzzing with speculation about how the money will be spent.

Rogers said it will immediately be used to wipe out the company's long-term debt. But he has arranged a \$1 billion line of credit with Canadian banks to finance the plans.

The program will have consumers paying more for their cable television this year and in future. But Rogers promised the increases will be less than the rate of inflation.

He said that in 1967, when he started offering cable, the cost per month in Toronto was \$4.50. Today, he said, the service is \$12 a month, far less than the average rise in prices during that time.

“This year there will be a significant rate increase,” he admitted. “But over the next 10 years, the increase for basic cable will be less than the cost of living.”

But if consumers are going to be spending more money, they will be getting more.

Watson said that, in the next few years, Rogers Cablesystems will spend \$300 per subscriber to ensure it can survive the growing competition from VCRs, home movies and satellite dish technology.

Fibre optic cables will ensure that Rogers will be able to provide 150 channels by 1998, compared with the current maximum 58. And when high-definition TV arrives, the equipment can pass on the clarity of the signal.

“HDTV will mean pictures that are three times sharper,” Watson said. “It will revolutionize TV and Rogers will be prepared for it.”

Watson said decision-making is being pushed down the line within the company to improve customer response time. An instant connect service will provide a faster method of hook-up and disconnection. That system is already being installed in apartments.

Fibre optics will also allow the company to add cable services, now limited by its equipment and regulations. Among the services available now are superstations in Atlanta and Virginia Beach, Va., and the USA Network as examples. In the Toronto area, regulatory approval is still needed for the two Buffalo UHF channels 23 and 49. They can be picked up only with an aerial.

“We are limited by the ability to provide them, rather than the supply,” Watson said.

George Fierheller, president of subsidiary Cantel, said the technology is creating the fastest developing industry in the world.

There are 3.8 million cellular phone users around the globe three years after its mass-market introduction. Some 6 percent are found in Canada.

Fierheller said Toronto has the highest cellular penetration rate per square kilometre of any city in the world.

Cantel, which competes with Bell Cellular, says it has 50 percent of the market share with 120,000 subscribers.

Fierheller said the company has a policy of keeping capacity 256 percent ahead of demand to cope with unexpected bursts of new subscribers.

“In Toronto demand almost ran away last summer,” he said.

Cantel is spending \$260 million this year, \$210 million in 1990 and another \$150 million in 1991 to expand its network and increase the number of channels in high-density areas such as Toronto, Montreal and Vancouver.

Fierheller said expansions will soon add Regina, Saskatoon, and Chicoutimi, Que., to the network, with others to follow.

Ontario Cuts Contribution to Radarsat Satellite Project

55200026 Ottawa *THE OTTAWA CITIZEN* in English
11 Mar 89 p E14

[Article: “Ontario Cuts Contribution to Satellite Project”]

[Text] Toronto (CP)—Ontario has cut its proposed contribution to the Radarsat satellite program because Quebec is getting more than its fair share of work on the project, Industry Minister Monte Kwinter says.

Kwinter said Ontario is proposing to contribute \$22 million to the \$550-million project, down from the \$29 million negotiated earlier.

"We can go to the \$29 million figure if there is a corresponding increase in the allocation of contracts to Ontario," Kwinter said.

Although Ontario has the largest aerospace industry of the provinces, Kwinter said there has been a steady whittling down of work that will be available to Ontario companies on the remote sensing radar program.

The Radarsat satellite is to be placed in polar orbit in the early 1990s.

The value of work for the province was cut to \$67 million from \$88 million between September 1988 and October 1987, "so we have reduced our contribution proportionately," he said.

Quebec, which will be contributing \$32 million, has seen the value of Radarsat contracts allocated to it rise to \$140 million from \$96 million, Kwinter said.

The Radarsat program, which received the go-ahead from the federal government in September 1987, originally was to involve Canada, the United States, Britain and four provincial governments—Ontario, Quebec, Saskatchewan and British Columbia.

Britain pulled out last year and the federal government agreed to pick up its tab.

The Ontario cabinet has not yet confirmed that the province will participate in the program.

The recent move by the federal government to locate a proposed new space agency in Montreal instead of Ottawa has left a sour taste.

"However, we are keeping an open mind," Kwinter said.

CBC Eyeing U.S. Market for Programs by Satellite

*55200030 Toronto THE GLOBE AND MAIL
in English 14 Apr 89 pp A1, A2*

[Article by John Partridge]

[Text] The Canadian Broadcasting Corp. board of directors has approved a scheme to beam television shows produced by the CBC and other Canadian broadcasters via satellite to U.S. cable TV subscribers.

The board gave the go-ahead to the plan to reverse the usual trans-border flow of TV programming at a meeting April 10, CBC president Pierre Juneau confirmed yesterday.

Assuming the federal cabinet approves the plan, CBC projections suggest that by 1999, the Canadian channel could be attracting viewers in as many as 44 million U.S. households and fetching as much as \$140-million a year in advertising revenue, another senior official of the public broadcaster said.

The projections also call for the proposed new service to break even during its fourth year of operation.

Start-up costs, Mr Juneau said in a telephone interview from Montreal, would most likely be covered through a line of credit of \$25-million on which the CBC could draw as necessary.

The credit line could be "from the banks or from the government," Mr Juneau said, although the CBC might also try to tap the U.S. media company it has lined up to package the service, beam it up to the satellite and sell it to U.S. cable companies.

"We're not expecting a (government) grant," Mr Juneau said. "Two weeks before a budget is not the time of discuss a grant."

The CBC president refused to name the U.S. company with which it has struck up the alliance. But cable industry sources in Canada speculate that it might be Eastern Microwave Inc of Syracuse, N.Y., Turner Broadcasting Systems Inc of Atlanta or one of several U.S. specialty cable channels such as the USA Network.

As the first step in getting cabinet approval, said Mr Juneau, the CBC has submitted a draft of the plan to the federal Department of Communications.

He said he doubted Communications Minister Marcel Masse has seen the draft but said Mr Masse has said he strongly supports the concept.

Mr Juneau said the first intention when the CBC started considering the idea several years ago was to try "to reverse the flow of information, drama and talent. We had no idea it could make a profit. But our research has showed it is much more practicable because it could be profitable."

The plan has changed somewhat since the CBC publicly proposed its creation in 1986 in a submission to the Caplan-Sauvageau task force on broadcasting policy.

For example, because of various legal and copyright wrinkles, the CBC abandoned the idea of turning its Windsor, Ont., station into a so-called superstation and beaming the signal to the satellite from there.

Instead, it now plans to put together the programs on video-tape in Canada and ship them to the U.S. company, which will insert commercials, CBC vice-president of planning John Shrewbridge said in a telephone interview from Ottawa.

Mr. Shrewbridge said that in addition to commercial time, the new channel would also derive revenue from cable subscriptions.

The current range for services included in basic cable packages is between 2 cents (U.S.) and 25 cents per subscriber per month, Mr Shrewbridge said. "We would expect to be very much at the low end," he added.

He said CBC projections suggest that in its first year of operations, the new channel would attract about five million cable subscribers, about 10 per cent of the U.S. total.

TV License Renewal Ties Canadian Content Spending to Revenues

*55200031 Toronto THE GLOBE AND MAIL
in English 7 Apr 89 p B3*

[Text] Hull, Que. Seventy-five television stations across Canada had their broadcast licences renewed yesterday and most will find their spending on Canadian programs has been tied to their financial performance for the first time.

The Canadian Radio-Television and Telecommunications Commission, which regulates the broadcast industry, expects the stations to spend at least \$2-billion on producing local Canadian shows over the next five years.

"We believe this approach will secure a level of spending on programming that is vital for continued improvement in the quality of local programs," Bud Sherman, interim CRTC chairman, said in a news release.

The commission has never monitored exactly how much stations spend on Canadian programs before. But CRTC spokesman Pierre Pontbriand said the commission expects spending over the next five years to increase about 12 per cent a year.

Until now, if a station improved its finances it did not have to spend any more money on Canadian shows. Now, the amount they put into domestic programs will rise with their total advertising revenues.

Private broadcasters, however, told the commission during cross-country public hearings in the fall that they expect advertising revenues will increase only about 5 to 6 percent a year in the next five years.

Michael McCabe, president of the Canadian Association of Broadcasters, said yesterday that 12 percent growth in program spending is quite optimistic.

However, he said his members—most private TV and radio broadcasters—are generally pleased with yesterday's decision because the levels of spending on Canadian programs set by the CRTC for the first year of the licence and the formula for increases are seen as fair, not onerous.

Low-Powered Microwave TV System Available for Remote Areas

*55200027 Toronto THE GLOBE AND MAIL
in English 18 Mar 89 p B6*

[Text] Winnipeg—A new television system demonstrated this week could bring affordable multi-channel TV to remote communities.

The low-powered microwave television system—developed by GEC Plessey Telecommunications (Canada) Ltd. of Winnipeg—will make it economically feasible for cable companies or community groups to provide a wide range of TV channels to small or remote towns.

Company President Bob Ashman said conventional high-powered microwave systems can transmit over greater distances but are prohibitively expensive for many such communities.

"As far as we are aware, this is the first low-powered system that has actually been built up and is commercially available in the world.

"There are other companies that are capable of (producing such a system), but they haven't done it."

GPT Canada—which field-tested the system in White-mouth, about 90 kilometres east of Winnipeg—sold its first system to Brandon-based Westman Media Cooperative Ltd. and hopes to be marketing it worldwide by the end of the year.

The company estimates there are 94 to 114 communities in Manitoba alone that could benefit from the system, including more than 50 native communities.

Mr Ashman said an estimated 20 percent of all households in the United States are now without cable TV service.

"Therefore, there clearly is a substantial potential market in the United States."

A station would pay \$40,000 for a new service, which is capable of distributing television signals to households within a 10-kilometre radius of the transmitting site. Subscribers will require a small roof-top antenna and a converter to receive the signals, and those items will be provided by the system owners.

Mr Ashman said the current model is an eight-channel system, but it can easily be expanded to handle up to 32.

A number of cable companies have expressed an interest in the low-powered unit to expand their existing system, he said.

Westman plans to use the system as an economical means to provide service in western Manitoba communities that it hasn't been able to reach with its cable network.

"This technology would fit in well with locations that are either difficult in terrain or difficult geographically in terms of distances between houses," said Tom Rooke, Westman marketing manager.

Operation Manager Leo Boivin said Westman will test the system this spring and summer in Winnipegosis. The central Manitoba town has a population of more than 1,000, but the community layout made it uneconomical for the cable company to provide service.

The firm hopes to obtain a licence from the Canadian Radio-Television and Telecommunications Commission later this year, and to begin providing full service to the community soon after.

FRANCE

Universal Network Breakthrough, 'Numeris'
*80190362b Paris MESSAGES in French No 381,
Dec 88-Jan 89 pp 44-46*

[Article by Laurence Reboul]

[Text] Launched a year ago in the Cotes-du-Nord, the Integrated Services Digital Network (ISDN) is today "coming out" in the Ile-de-France. From a first worldwide technology, we will have to achieve from now on an exemplary commercial success. Nothing like such an enormous stake to mobilize all energies at France Telecom. An effervescence bubbling around the new name of the commercial baptism of the network: "Numeris."

The ISDN is no longer a myth. It is a reality. In December of 1987, it started for the first time in the world in the Cotes-du-Nord, in Brittany, with 300 firm subscribers at the end of 1988. Today, it is being installed in the Ile-de-France. Solidly. Objectives in the Paris region alone: 300 subscribers by the end of 1988, 1,300 by the end of 1989, over 5,000 by the end of 1990. To have this "first worldwide" technique become an exemplary commercial success, the entire France Telecom is on deck. General mobilization. From the commercial representative to the project team of the commercial division of Ile-de-France, from the SSII engineer to "product support,"¹ from the man in charge of the professional telecommunications center to the head of the national ISDN delegation, Jerome Remy. And, at the highest level, mobilization of the general manager of France Telecom and the minister Paul Quiles, who has recently qualified the ISDN as "immensely advanced" and has led the search for a commercial name: "Numeris" was chosen.

On a Friday morning in the promotion center of professional telecommunications of the Defense, in East Paris, in the heart of this gigantic business complex bristling with activity.

"Your communications needs are increasingly important; the volume of data you exchange never ceases to grow; the services, the terminal and the networks are multiplying. The management of communication is therefore more and more complex in your organization, thus ever higher equipment and development costs!" announces Fernand Neu, the ISDN "product support," to a dozen people who have come from all professional horizons to discover the "universal threat" (see MESSAGES No 377, p 34). And he continues on the exceptional opportunity of rationalizing and improving this communication with ... Numeris.

Then come demonstrations and explanations, "technical" without being too much so: "Numeris offers two channels with 64 Kbit/s and one signalization channel with 16 Kbit/s. Whereas the telephone network alone supports only 9.6 Kbit/2—i.e. a yield which is 15 times lower—and Transcom, the pre-ISDN network, offers only a channel with 64 Kbit/s. With the ISDN, a single cabling, a single take for the telephone, the style and the information." The "product support" links up with the qualitative contributions of the ISDN² and, obviously, all services provided by this network. Fernand Neu accompanies his very structured speech with transparencies and diagrams rapidly outlined on the paper board. With the rather timid, and in this case quite technical questions from potential clients, the whole took one hour. Then, a "true scale" demonstration. The center of professional telecommunications of the Defense—and the two other centers of the Paris district affected by the present ISDN opening, rue du Louvre de Paris, and at Montrouge—is remarkably well equipped and organized for such demonstrations. Everything is there: these first-rate ISDN terminals which were largely absent in the great international exposition in Geneva last fall³, and quite spectacular application examples. The Group IV telecopier with its speed⁴, with the astonishing quality of its photo telecopies due to its 16 levels of grey, with its possibility of memorizing pages before sending them, has tailored a great success for itself.

More enthusiasm for what is called "Telephony Plus." Fernand Neu communications with a correspondent and at the same time looks for a number composing the 11. At the same time, someone calls him and leaves his number⁵: this number appears on Fernand Neu's telephone screen—"call waiting"—who puts his first communication on hold to talk to his second caller, and then returns to the first. In all this time, counting of the telecommunication units continued on the mini screen of the terminal. Then a third party calls. Unable to get a response, he leaves his phone number and even a message. As long as his call has not been returned, these two data remain in the terminal memory.

Last demonstration of the telephone services, this one the most spectacular: in the course of communication, taking advantage of the fact that his caller has gone to look for a document, Fernand Neu disconnects his terminal to reconnect it a little closer, near his office.

Data Transmission Becomes Common

"Telephony Plus," however, is only a rather minor aspect of the vast possibilities of the ISDN. It is in the sector of data transmission that its capabilities are miraculous: speed and quality of card indices, but also, more demonstratively, transmission of fixed images. Thus, the Bureau of Tourism in Brittany shows with images of photographic quality the different possibilities of vacationing on its coasts. Images, but also sound—digital, i.e. of excellent quality.

"The ISDN - making data transmission commonplace. An astonishing and high-performance tool is made available to the smallest businesses", concludes Francis Darguepeyrou, head of the promotion center at Defense.

Each of the potential clients, about a dozen, comes to assist Defense in Friday's Demonstration, which is the 25th of its type. Each has been contacted by a commercial representative of one of the commercial agencies from the operations management (DO) of Nanterre, on whom the promotion center also depends. Either by a commercial representative "professionals," i.e. in charge of the PME on the sector, or a commercial representative "businesses" in charge of several "big accounts."

Change of decor: On the ground floor of a building in a small, very busy street in the first arrondissement of Paris, there is the headquarters of a "tour operator," a travel wholesaler. His clients are the travel agencies themselves.

Serge Merelle, the commercial representative of the telecommunications agency Louvre, quite nearby, who is in charge of this client, has made an appointment with the business manager. To specify the organization and the telecom use of the "tour operator" (Green Number, telecopy, telex ...). With Fr60-80,000 per month in telecommunications expenses, this is one of the large accounts of the Louvre agency. Serge Merelle will show him therefore the ISDN on the occasion of this visit. No technical details, only a first approach to show what ISDN can concretely bring to this "tour operator" in almost daily connection with some 40 agencies in France. An example: Does one of them want to draw the last benefit from the program "Portugal by Car?" The two pages of the brochure, with prices but also photographs of the hotels, will be transmitted to him on his ISDN image terminal.

A fast and sober presentation, but one which will arouse the client's interest. This first contact with the ISDN will probably be followed by others on his demand.

At the professional telecommunications center of the Louvre, Wednesday, October 12, 1988 is a big day. The general management of the bankers' group La Henin has come in force—about twenty people—to "understand" the ISDN. Everything is there to make a grand show: large-screen video, audioconference-type connection with the promotion center of Defense, demonstrations every quarter of the tour. Nothing has been left to chance. Jean-Claude Vicarini, the director of operations of Paris-Nord—on which the center depends—has taken it upon himself to personally preside over the entire meeting. To sell the ISDN, three examples of commercial approaches responding to different situations: clients spontaneously interested or canvassed, presentations at the client's or in a telecom center, collective or individual demonstration, the principle being adaptation to the demands of and profit to the client.

We Must Create an Effect of Enthusiasm

"After ten or so presentations, we have adjusted the fire. Instead of presenting the ISDN to an individual, which is inevitably somewhat monotonous, we have gone to two, talking alternatively. We also try to get our clients' imagination to work, to make them participate, and to make the demonstration more entertaining," explains Serge Merelle. "We have even created a video clip," emphasizes Claire Perois, who is also a commercial representative and often works as a team with Serge Merelle.

Her interest in this new France Telecom challenge is obvious. Claire is 22 years old and, as for most of the commercial representatives of the new generation, the ISDN is her "new frontier." She can no longer count the number of clients to whom she has shown it.

It is the first time that the commercial force of France Telecom must really sell. Up until now, the demand of SDA (direct selections at arrival), of specialized connections and other products earmarked for business by the clients of France Telecom had been so strong that the commercial representative could be satisfied with dealing with it without having to deliver it. At least in the Paris sector.

Today, France Telecom must create a network effect, an effect of drive, so that an ISDN user linked up can rapidly join the greatest number of ISDN users, and the applications are available at both ends of the line. For that matter, the Cotes-du-Nord pioneers have not really been able to let their Paris counterparts benefit from their experience: the industrial fabrics are too different. On the one hand, many small businesses, on the other, many large-scale corporations or large PME.

In the years from 1992 to 1995, France Telecom will have to be ready to offer ISDN connections to all subscribers, whereas today the potential clients are exclusively in business. They are either large companies whose telephone, office and information applications are

at present assured in part by private multi-service auto-communicators, or they are medium sized companies who need to expand their telephone service, and which gradually will have access to various current networks to broaden their panoply of services.

Twenty Conventions Have Been Signed

In the Paris area, 15 sectors to prospect at priority⁶ have been defined after two market studies done in 1987 by the consultant firm M21. Since January 1988, a dossier of 3,000 "prospects," i.e. establishments to be prospected, has been set up: 1,200 for each of the operational managements North and South, and 600 for the operational management of Nanterre.

"This was the date when prospecting truly began," remembers Laurent Claude, head of the ISDN project team in the regional management Ile-de-France (DRIF). "Prospectives were set up first by the product supports of the three operations managements concerned. Then, progressively expanded to commercial agencies, the product supports will provide them with essential informative, technical and logistic support."

In early October, the two thirds of the three thousand companies selected with priority had gone through the fine comb. Among them, certain ones have become privileged ISDN "partners" of France Telecom. And, thanks to the action of a third player of its commercial force: the consulting ISDN engineer, still called SSII engineer, because he is detached in most cases from a service organization in engineering and information technology—there are eight in the Paris area, and soon there will be a dozen. A point of departure is an original, novel, exemplary application idea of the ISDN. A technical, financial and commercial dossier is then set up. If it is accepted by the Committee of Applications of France Telecom, the two or three partners—management, the client, perhaps a provider of services, etc—sign an agreement. To date, twenty have been signed and fifteen are being negotiated in sectors as diverse as pharmaceutical laboratories, gas, real estate, mail-order services. One of the last agreements to date was concluded with the fourth French photography agency, Kipa. Its challenge is to diffuse 6-7,000 photographs per week to the 150 press supports—dailies, magazines, television—which subscribe either continuous round trips by guide channel, postal means or taxi, so that his clients can select the photograph ad hoc.

The ISDN solution will eventually digitize the entire stock of photographs of Kipa, and it will become an image bank available in real time. The client will receive on the screen of his ISDN terminal a selection of photographs and can then "zoom" on the one he chooses. Depending on the support, he will edit the digitized image as is or he will have the selected specimen sent to him. With the single condition that the clients be connected to the ISDN under the same title as Kipa. The partner company will thus of necessity preach

for the ISDN all around it. The network effect is thus induced by the client himself. "The partnership is the king-pin of the commercial policy of the ISDN," concludes Laurent Claude.

However, this is only a start. Most of the applications remain to be invented. The sun is far from setting over the Telecom space!

Footnotes

1. A "product support" is a commercial France Telecom engineer connected with an operational management, who has all the technical and commercial competence tied to one or several products. Furthermore, there are "office," "vocal," and "data transmission" supports for the ISDN products. A total of eleven ISDN product supports are available on the three operational management systems of the Paris sector.

2. The low error rate is at most 1 bit of error on 108 bits transported; short transfer time, high availability.

3. "Telecom 87."

4. A full 8.5x11 typewritten page is transmitted in six seconds. However, a photograph with many nuances will take about two minutes.

5. The caller may wish to remain anonymous and not reveal his number. It suffices for him to program this function—non-identification of the call—on his station.

6. Particularly, engineering or information service companies, large industrial corporations, the pharmaceutical sector, banks and insurance companies, the communications and tourism sector.

Alcatel Firm Profits from CEMA Relaxation *55002455 Paris L'USINE NOUVELLE in French 9 Mar 89 p 31*

[Article by Jean-Pierre Jolivet: "Alcatel Answers the Call of the East"; first sentence is L'USINE NOUVELLE subhead.]

[Text] With 250,000 lines for the Soviet Union, new contracts in sight in China and Vietnam, and offensive negotiations in Eastern Europe, Alcatel NV is in a good position to take advantage of the relaxation of CEMA [Council for Economic and Mutual Assistance] regulations.

Confident in the commercial repercussions of perestroika, Alcatel NV's Paris headquarters says that "it is only a matter of time" before it will be supplying telephone exchanges to the Soviet Union. If chosen, the world's number-two telecommunications company will supply 250,000 lines of its digital S12 system through its Belgian subsidiary BTM (Bell Telephone Manufacturing). The second step will be for BTM to create a joint

venture with the local Leningrad Krashna Zaraya company for the production of 1 to 1.5 million lines a year. In all, the contract will bring BTM more than 6 billion francs over a 10-year period. However, it is still waiting for the go-ahead from the Belgian government and, no less important, the CEMA.

Like its major competitors on this bid (Ericsson, AT&T, Siemens, and the Japanese), Alcatel NV has its eyes on a fabulous market. With only 36 million telephone lines, the Soviet Union wants to correct an equipment shortage that has persisted despite a contract signed with Thomson-CSF Telephonique in the late 1970's. Under this licensing agreement, come what may, the Leningrad factory turns out 300,000 MT25 lines a year: not enough for a Soviet population of 280 million. The current plan calls for increasing annual investment in telecommunications from 10 billion to over 35 billion francs in 1995, in order to reach a goal of 100 million lines by the year 2000.

With the advent of perestroika and the relaxation of sacrosanct CEMA regulations, Alcatel NV (70 billion francs, with 25 percent in switching) does not intend to miss out on the eagerly awaited opening of the Eastern countries. In China, where it already holds 40 percent of the switching market with its S12 and E10 systems, Europe's leading telecommunications company has its sites on new contracts. In Vietnam, the first results of this offensive are in. Alcatel-CIT [Alcatel-International Telecommunications Company] recently signed a memo for the supply of 53,000 E10 lines to Hanoi and Ho Chi Minh Ville, and it has just been notified of a first 28-million-franc contract for 12,000 lines for Hanoi.

In Eastern Europe, the historic market of the erstwhile CIT, Alcatel NV's French subsidiary is renewing its relationships with E10 user countries. In Bulgaria, it is negotiating in the face of Italian and British competition, and similar efforts are underway in Poland and Czechoslovakia, which also have E10 equipment.

Alcatel NV is looking to these underequipped markets to take the place of Western Europe (which has attained cruising speed) and the financially troubled countries of the third world. However, once again, the European leader will have to contend with its principal competitors.

NORWAY

Country Seen Wanting Out of TELE-X Project
55002458 Oslo AFTENPOSTEN in Norwegian
10 Mar 89 p 56

[Article by Rolf L. Larsen: "Norway Wants Out of Tele-X"]

[Text] From what AFTENPOSTEN has learned, Norway wants to pull out of the controversial Tele-X program. The satellite is to be launched from French Guyana in South America on 1 April.

An official Norwegian Government delegation is negotiating in Stockholm concerning the compensation that Norway will get if it withdraws from the cooperative effort. Norwegian television and Norwegian industry have invested about 180 million kroner in Tele-X. From what AFTENPOSTEN has learned from a well-informed source, Norway will request use of one TV channel on the satellite, which will have three TV channels and two channels for data and video transmission.

"There is consensus between Swedish and Norwegian authorities that the governmental agreement should now be changed. A new ownership structure for operation of the satellite will also be created," State Secretary Karin Stoltenberg of the Ministry of Industry tells AFTENPOSTEN.

The governmental agreement on Tele-X collaboration between Sweden and Norway was concluded on 1 April 1983. The changes which the two governments now want to make, according to what AFTENPOSTEN understands, must be approved by the Storting and the Riksdag.

2 Billion

The Tele-X program will have cost about 2 billion 1989-kroner when the satellite probably goes into orbit in April. An agreement has not been reached on insurance for the satellite. It is being launched as the single payload on board an Ariane rocket from the European Space Organization's (ESA's) launch pad in French Guyana in South America. The launch is taking place a good 2 years later than planned.

Denmark and Finland have earlier pulled out of this satellite collaboration which subsequently has become very "turbulent." Especially on a political and an industrial-policy plane. The Swedish Ministry of Industry is now playing a powerful role in what is happening during the final lap of the Tele-X matter. The Nordic Satellite Stock Company (NSAB) owns the satellite, but the state-owned Swedish Rymbolaget—which is subordinate to the Ministry of Industry—manages Tele-X. Sweden owns 85 percent of the Satellite. Norway 15 percent.

Up until now, the view has been that the Swedish and Norwegian television networks should operate the satellite on a 50-50 basis, through the NOTELSAT company in Stockholm. Now, apparently, this management scheme is falling apart. The Swedes are interested in establishing their own Swedish management company. From what AFTENPOSTEN understands, they want to form a daughter company to the Rymbdbolaget, which will be concerned with this management.

Uncertain Future for Nittedal Station

The earth station for Tele-X lies in the Nittedal, outside Oslo. If Norway pulls out of the Tele-X program, it is uncertain what will become of the equipment there.

The Nittedal station was supposed to be Norway's "flag ship" in the Tele-X program. Now personnel at the station are waiting anxiously to see what will happen further with regard to ownership and management of the satellite. Provisionally, there is talk of setting aside a smaller part of the equipment. Portions of the control equipment for the data and video section is supposed to go to the Swedes' ground and control station for Tele-X in Kiruna.

There is Tele-X equipment worth approximately 60 million Kroner at the advanced ground station in the Nittedal. From Nittedal, TV transmissions will be sent to the Tele-X satellite approximately 36,000 km out in space and then down to small parabolic antennas throughout Scandinavia.

Outside the advanced earth station, two large parabolic antennas stand ready to pass traffic to and from the satellite. A group of television experts is now carrying out a thorough test of the equipment. They are testing it with a simulated "satellite" which has been placed on the Varingskollen. "Tests that have been made so far indicate very good quality," says section engineer Frank Belika.

He is the project chief for the Tele-X program at the Nittedal station.

SPAIN

Northern Telecom-Amper Negotiating Switchboard Agreement 35480099z Madrid DIARIO 16 in Spanish 18 Mar 89 p 44

[Article by Pedro G. Cuartango]

[Text] The Canadian firm, Northern Telecom, is negotiating to establish a joint venture with Amper, a company with ties to Telefonica, to manufacture digital switchboards. The discussions are now in an exploratory phase.

The majority of this joint venture would belong to the Canadian firm, which is the fourth largest telecommunications company in the world, following ATT, Alcatel and Siemens.

Northern Telecom holds 18 percent of the switchboard market in the United States, a market estimated at 1 million private telephone lines. In switching equipment, it is the Bell Companies' second leading supplier.

The Canadian firm does not sell public telephone exchanges in Europe and wants to establish a marginal presence in the switchboards market. Its association with Amper would place it in a good position for access to the Spanish market, estimated at about 100,000 lines a year.

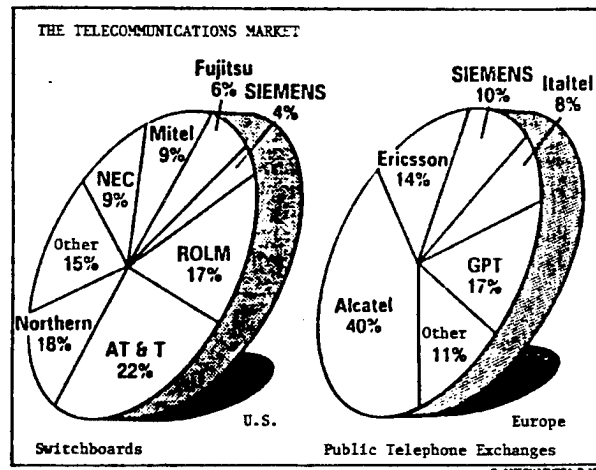

Advanced Technology

The switchboards that Northern Telecom is manufacturing in the United States and Canada are considered the most advanced in the world. The latest generation of this equipment is used to route normal telephone traffic, but it can also handle high-speed data and image transmission.

Amper, of which Telefonica holds 12 percent, is now selling switchboards manufactured by Alcatel and Ericsson, Telefonica's two major suppliers. The Spanish firm produces multi-line telephones, but not switchboards.

For Northern Telecom, this joint venture with Amper would hold out the possibility of establishing an industrial foothold for the Common Market countries. At the present time, 90 percent of its earnings comes from the United States and Canada.

The operation that Northern Telecom is attempting parallels efforts by the European manufacturers, Siemens, Alcatel and Ericsson, to enter the North American market, now dominated by ATT and the Canadian firm.

A few months ago, the German electronics giant, Siemens, acquired Rolm, a strong competitor of Northern Telecom in the United States. Rolm had been a subsidiary of IBM, which has decided to get out of the telecommunications business.

Oddly, though, about 4 years ago Telefonica was negotiating with Rolm to set up a plant in Spain, but the talks collapsed and the U.S. firm decided to go to Great Britain.

Contacts with Rolm

Until now in Spain, the sale of digital switchboards has been subject to the control of Telefonica which, using a restrictive policy of required approvals, protects its preferred suppliers.

This is going to change after passage of the Telecommunications Planning and Development Law, which calls for deregulating the switchboards and terminals market. The government has drafted a regulation which allows

the free marketing of digital switchboards (marketing of analog switchboards has already been deregulated).

The regulation has already been sent to the European Commission in Brussels, which will certainly give its approval within a few weeks.

SWEDEN

Digital Switching Stations From Ericsson

55002460 *Stockholm DAGENS NYHETER in Swedish*
15 Mar 89 p 12

[Text] Ericsson has entered into still another framework agreement with China, which in a first stage is expected

to result in a contract worth 200 million kronor. Ericsson is to deliver 12 digital AXE switching stations. These are to be used for local traffic, both directly to subscribers and between local stations in the Ningbo area, which is approximately 30 [Swedish] miles south of Shanghai. The AXE agreement also includes power and transmission equipment. The AXE units are to be fabricated by Ericsson's design and production facility in Melbourne, with installation taking place in the period 1990-91.

22161

44

NTIS

ATTN: PROCESS 103

5285 PORT ROYAL RD

SPRINGFIELD, VA

22161

This is a U.S. Government publication. Its contents in no way represent the policies, views, or attitudes of the U.S. Government. Users of this publication may cite FBIS or JPRS provided they do so in a manner clearly identifying them as the secondary source.

Foreign Broadcast Information Service (FBIS) and Joint Publications Research Service (JPRS) publications contain political, economic, military, and sociological news, commentary, and other information, as well as scientific and technical data and reports. All information has been obtained from foreign radio and television broadcasts, news agency transmissions, newspapers, books, and periodicals. Items generally are processed from the first or best available source; it should not be inferred that they have been disseminated only in the medium, in the language, or to the area indicated. Items from foreign language sources are translated; those from English-language sources are transcribed, with personal and place names rendered in accordance with FBIS transliteration style.

Headlines, editorial reports, and material enclosed in brackets [] are supplied by FBIS/JPRS. Processing indicators such as [Text] or [Excerpts] in the first line of each item indicate how the information was processed from the original. Unfamiliar names rendered phonetically are enclosed in parentheses. Words or names preceded by a question mark and enclosed in parentheses were not clear from the original source but have been supplied as appropriate to the context. Other unattributed parenthetical notes within the body of an item originate with the source. Times within items are as given by the source. Passages in boldface or italics are as published.

SUBSCRIPTION/PROCUREMENT INFORMATION

The FBIS DAILY REPORT contains current news and information and is published Monday through Friday in eight volumes: China, East Europe, Soviet Union, East Asia, Near East & South Asia, Sub-Saharan Africa, Latin America, and West Europe. Supplements to the DAILY REPORTS may also be available periodically and will be distributed to regular DAILY REPORT subscribers. JPRS publications, which include approximately 50 regional, worldwide, and topical reports, generally contain less time-sensitive information and are published periodically.

Current DAILY REPORTS and JPRS publications are listed in *Government Reports Announcements* issued semimonthly by the National Technical Information Service (NTIS), 5285 Port Royal Road, Springfield, Virginia 22161 and the *Monthly Catalog of U.S. Government Publications* issued by the Superintendent of Documents, U.S. Government Printing Office, Washington, D.C. 20402.

The public may subscribe to either hardcover or microfiche versions of the DAILY REPORTS and JPRS publications through NTIS at the above address or by calling (703) 487-4630. Subscription rates will be

provided by NTIS upon request. Subscriptions are available outside the United States from NTIS or appointed foreign dealers. New subscribers should expect a 30-day delay in receipt of the first issue.

U.S. Government offices may obtain subscriptions to the DAILY REPORTS or JPRS publications (hardcover or microfiche) at no charge through their sponsoring organizations. For additional information or assistance, call FBIS, (202) 338-6735, or write to P.O. Box 2604, Washington, D.C. 20013. Department of Defense consumers are required to submit requests through appropriate command validation channels to DIA, RTS-2C, Washington, D.C. 20301. (Telephone: (202) 373-3771, Autovon: 243-3771.)

Back issues or single copies of the DAILY REPORTS and JPRS publications are not available. Both the DAILY REPORTS and the JPRS publications are on file for public reference at the Library of Congress and at many Federal Depository Libraries. Reference copies may also be seen at many public and university libraries throughout the United States.