

JPRS-JST-90-033

11 JULY 1990



**FOREIGN
BROADCAST
INFORMATION
SERVICE**

JPRS Report

Science & Technology

Japan

19980130 063

REPRODUCED BY
U.S. DEPARTMENT OF COMMERCE
NATIONAL TECHNICAL INFORMATION SERVICE
SPRINGFIELD, VA. 22161

DMC QUALITY INSPECTED 3

DISTRIBUTION STATEMENT A

Approved for public release;
Distribution Unlimited

SCIENCE & TECHNOLOGY
JAPAN
CONTENTS

ADVANCED MATERIALS

- Organosilicon Polymer for New Ceramics
[Taketami Yamamura; ZAIRYO KAGAKU SEMINAR, 13 Apr 90]..... 1

BIOTECHNOLOGY

- Overview of Pollution Control Biosensors
[JITA NEWS, 1 Feb 90]..... 8

SCIENCE & TECHNOLOGY POLICY

- Nuclear Power Public Opinion Poll Released
[GENSHIRYOKU SNAGYO SHIMBUN, 25 Jan 90]..... 28

TELECOMMUNICATIONS R&D

- MPT Report on ISDN Terminal Connectivity Described
[ISDN TANMATSU NADO NO SOGO SETSUZOKUSEI, SOGO
UNYOSEI NO KOJO NI KANSURU GAIDORAIN, 1989]..... 37

- Proposal of Virtual Circuit Multiple Access System
[Fumihito Kubota, Kazunori Okada; TSUSHIN SOGO
KENKYUSHO KENKYU HAPPYOKAI, 15 Nov 89]..... 43

Organosilicon Polymer for New Ceramics

90FE0147 Tokyo ZAIRYO KAGAKU SEMINAR in Japanese 13 Apr 90 pp 55-59

[Article written by Taketami Yamamura, Ube Research Institute, Ube Industries, Ltd.]

[Text] 1. Introduction

The organic metal-crosslinked polymer called polytitanocarbosilane can be converted at a high yield into inorganic compounds consisting of silicon, titanium, carbon and oxygen, by heating to a temperature higher than 800°C in an inert gas atmosphere. By taking advantage of this property, we are trying to develop a Si-Ti-C-O base inorganic fiber (Tyranno^(R) fiber), which has high heat resistance and high mechanical properties, and several composite materials using this fiber. In this paper, I will discuss the characteristics of this organic metal-crosslinked polymer, the characteristics of this fiber, and new types of ceramic composites containing this fiber.

2. Production and Characteristics of Organic Metal-Crosslinked Polymer

The production process for polytitanocarbosilane (PTC) is explained in Figure 1. PTC is produced by hot condensation polymerization from polydimethylsilane, which is synthesized by dechlorinating condensation-polymerization of dimethyl-dichloro-silane, with the addition of a small amount of polyborodiphenyl-siloxane, which is obtained by condensation polymerization of diphenyl-dichloro-silane and boric acid, and an appropriate amount of a titanium compound. Shown in Figure 2 is the basic structural unit of PTC as estimated from the results of infrared measurements, ²⁹Si-NMR measurements, elemental analyses, and ultraviolet measurements. In the PTC formation reactions, the following reactions occur either successively or simultaneously and polyborodiphenyl-siloxane functions as a promoter for these reactions: the pyrolysis of the Si-Si bond in polysilane, the formation of Si-H bond and Si-CH₂-Si bonds accompanying the pyrolysis, the condensation of Si-H bond and the crosslinking by a titanium compound.

The characteristics of PTC are as follows:

(1) When calcined in an atmosphere of inert gas or non-oxidizing gas, or in a vacuum, PTC is converted first to an amorphous state containing silicon and titanium, and in some cases, also oxygen, then to a microcrystalline state consisting of β -SiC and solid solution of TiC and β -SiC, and finally, at high temperatures, to a crystalline state.

(2) PTC melts upon heating and makes it easy to form shapes. Thus, after a desired shape, such as fiber or thin film, is formed, PTC is heated to yield various products consisting of the new ceramics, mentioned in (1) above, with high heat resistance and high mechanical properties. In this manner, it is possible to manufacture complex-shaped products that it has never been possible to manufacture by any inorganic chemical method.

(3) Because it is readily soluble in many organic solvents, PTC can be used for heat-resistant paints and ceramic impregnants. It is also possible to manufacture ceramic products by blending the polymer's solution with ceramic powders, and by drying, shaping and sintering the blends.

3. Production and Properties of Tyranno^(R) Fiber

Tyranno^(R) fiber is produced by melt-spinning PTC, heat-treating the spun fibers to stabilize, and finally by calcining them. The heat treatment for stabilization is a process of heating the fibers in air to a temperature below 200°C to prevent them from losing the fiber shape during the calcination. By this treatment, the spun fibers become unmeltable through crosslinking by oxygen in air. The calcination is done by continually treating the crosslinked fibers in nitrogen at a temperature between 1,000 and 1,500°C.

The characteristics of Tyranno^(R) fiber are summarized in Table 1. Tyranno^(R) fiber, comprised of fibers of Si, Ti, C and O, maintains an amorphous structure up to a high temperature of 1,400°C. The filament diameter, greater than eight μm , can be freely controlled, and its fluctuations can be controlled to $\pm 1.5 \mu\text{m}$. The fiber's tensile strength and tensile modulus are 3.0 to 3.6 GPa and 180 to 200 GPa, respectively. In addition to the excellent mechanical properties, the fiber's density is approximately 2.3 to 2.4 g/cm^3 , which makes the fiber suitable for the formation of composites in need of weight reduction. The fiber's thermal expansion coefficient is small at 3.1 to 3.4 $\times 10^{-6}/^\circ\text{C}$, without showing much difference in either fiber's axial or radial direction. As shown in the table, Tyranno^(R) fiber has a larger tensile strain-to-failure value of 1.5 to 2.0 percent, which is greater than normal inorganic fibers. Because its knot strength is as great as carbon fibers of the grade that is commonly used for textiles, as seen in Figure 3, Tyranno^(R) fiber can be readily woven into various complex textiles, including plain webs, damasks, braids and three-dimensional textiles. The anti-oxidation stability of Tyranno^(R) fiber is compared with other inorganic fibers' in Figure 4 (fibers' tensile strength values determined at room temperature after one-hour treatment in air at various temperatures). As clearly indicated by the graph, this fiber has better anti-oxidation property than other inorganic fibers. Furthermore, it is considerably strong at 1,300°C, as shown in Figure 5, where high-temperature

tensile strength values are graphed. In a heat-treatment test in an argon atmosphere up to 2,100°C, as illustrated in Figure 6, Tyranno^(R) fiber is found to show excellent heat resistance by maintaining its fiber form up to 2,000°C because grain crystallization is suppressed by a titanium compound (TiC), whereas inorganic fibers (excluding carbon fibers), such as SiC fiber, become powders at 1,800°C because their crystal growths are significantly accelerated. It is also possible to produce Tyranno^(R) fibers with diverse electrical conductivity by controlling the fiber composition and the production conditions. Shown in Table 2 are the specific resistance values and mechanical strengths for several Tyranno^(R) fibers (A through G). The specific resistance values for glass fiber and carbon fiber are 10^{12} to 10^{15} ohm.cm and 10^{-3} to 10^{-4} ohm.cm, respectively. In contrast, the specific resistance values for Tyranno^(R) fibers can range widely from 10^7 ohm.cm to 10^{-1} ohm.cm.

4. Ceramic Composites Containing Tyranno^(R) Fiber

According to the production methods given in Figure 7, a ceramic composite is made as a laminate of Tyranno^(R) fiber's plain web and an unidirectionally oriented sheet (UD-sheet), and another composite is made from a UD-sheet and PTC inorganic powder. The relationship of the density and three-point bending strength for one of the composites is shown in Figure 8. A straight-line relationship is seen between the density and the bending strength for either composite. Different density and bending strength values are obtained depending on the composite's composition and the production conditions including the hot press temperature, the rate of temperature increase and pressure.

Photographs in Figure 9 show the crosssections of bending fractures of these composites. The original shape of Tyranno^(R) fibers used for the composites is cylindrical. However, by hot-press process at a temperature higher than 1,800°C, the fibers change their shape from a cylinder to a hexagonal pillar in order to assume the tightest packing in the composites, according to the photographs. During this transformation of the fibers in the hot-press process, portions of carbon and oxygen in the fibers escape from them as carbon monoxide.

The high-temperature bending strengths in air for these composites are shown in Figure 10. The graph shows that the composites maintain the room-temperature strength even at 1,400°C. The load-displacement curves at the time of bending strength tests at 1,400°C, as shown in Figure 11, show that the composites' fracture energy values are significantly greater than that for the ceramic made only of Si-Ti-C-O powder. This new type composite, which maintains strength to above 1,400°C₃ in air, and shows a fracture toughness value, k_{IC} , of more than $15 \text{ MNm}^{3/2}$, is promising as a future highly heat-resistant material.

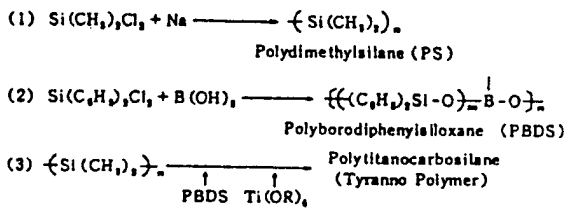

Figure 1. Production of Polytitanocarbosilane

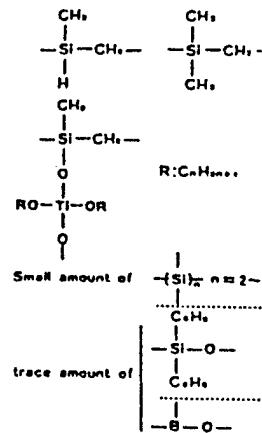

Figure 2. Unit structures of PTC

Table 1. Physical properties of the Si-Ti-C-O fiber.

Composition (wt%)	Si: 48-57, C: 30-32
	Ti: 2.0, O: 12-18
	B : ≤ 0.1
Filament Diameter (μm)	8.5+1.0
Filament/Yarn	1600
Tex	200
Density (at 25°C, g/cm^3)	2.3-2.4
Tensile Strength (GPa)	3.0-3.6
Tensile Modulus (GPa)	180-200
Tensile Strain to Failure (%)	1.5-2.0
Coefficient of Thermal Expansion ($^{\circ}\text{C}^{-1}$)	
(along fiber axis, 0-500°C)	$3.1-3.4 \times 10^{-6}$
Specific Heat (cal/deg/g)	-0.19(300K)
	-0.28(670K)

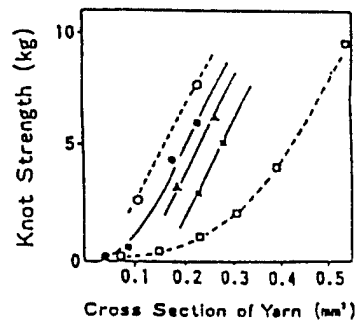

Figure 3. Knot strength of Carbon fiber (7 μm ; ---○---), Si-Ti-C-O fiber (8.5 μm ; —●—, 10 μm ; —▲—, 11 μm ; —■—) and SiC fiber (14 μm ; ---□---)

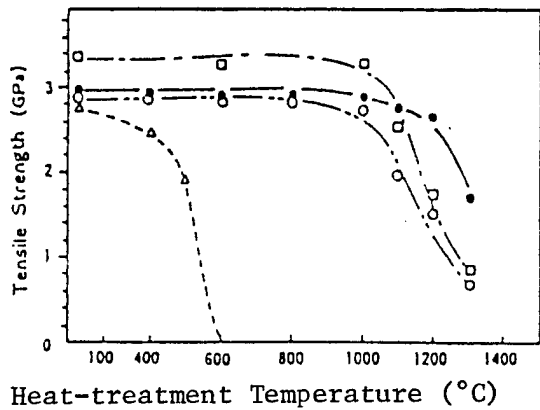

Figure 4. Heat-resistance of Carbon fiber (--- Δ ---), SiC fiber (— \circ —), SiC/C fiber (--- \square ---) and Si-Ti-C-O fiber (— \bullet —)

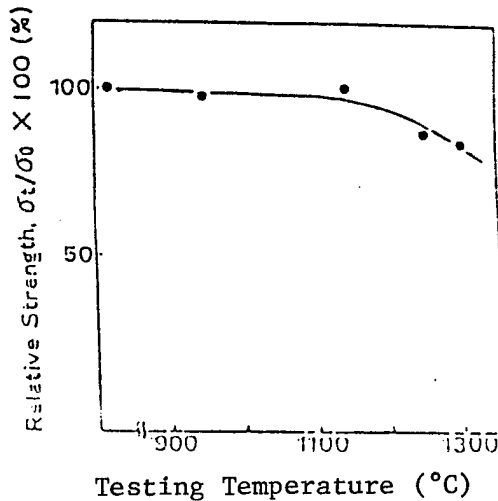

Figure 5. Tensile strength at high temperature of Si-Ti-C-O fiber

Table 2. The relationship between the mechanical strengths and the specific resistances of Si-Ti-C-O fiber.

Type	Specific Resistance (ohm \cdot cm)	Tensile Strength (GPa)	Tensile Modulus (GPa)
A	$10^6 - 10^7$	2.4 - 3.0	130 - 150
B	$10^5 - 10^6$	2.6 - 3.2	150 - 170
C	$10^4 - 10^5$	2.8 - 3.4	160 - 180
D	$10^3 - 10^4$	2.8 - 3.6	170 - 190
E	$10^2 - 10^3$	2.8 - 3.6	170 - 190
F	$10^1 - 10^2$	2.8 - 3.6	160 - 180
G*	$10^0 - 10^1$	2.8 - 3.6	160 - 180
S	---	2.8 - 3.6	170 - 190

* G type is still under developing

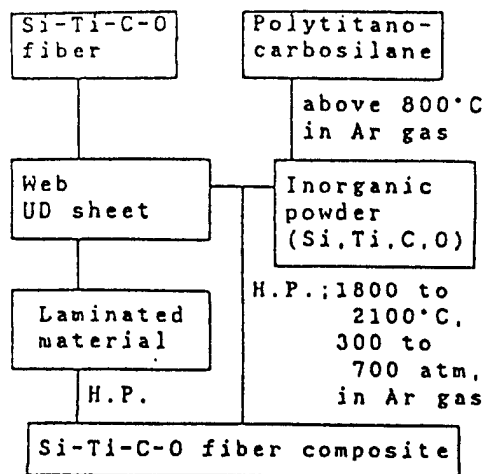

Figure 7. Manufacturing process of Si-Ti-C-O composites.

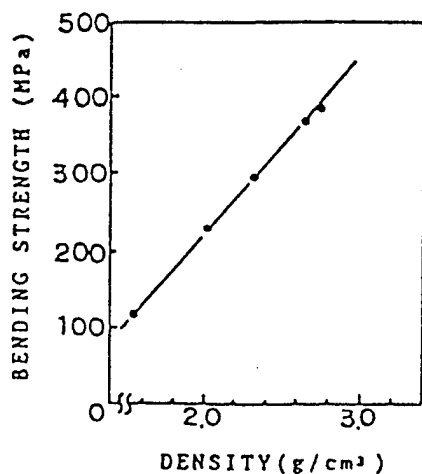

Figure 8. Relationship between apparent density and bending strength of CMC using Si-Ti-C-O fiber.

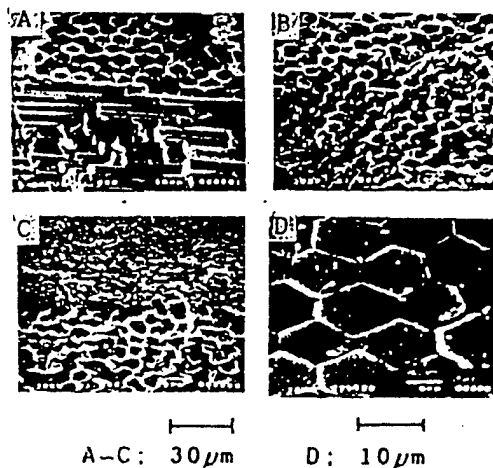

Figure 9. Fracture surface of CMC using Si-Ti-C-O fiber.

- A: plane web
- B: UD sheet
- C: UD sheet + powder
- D: hexagonal columnar structure of fibers

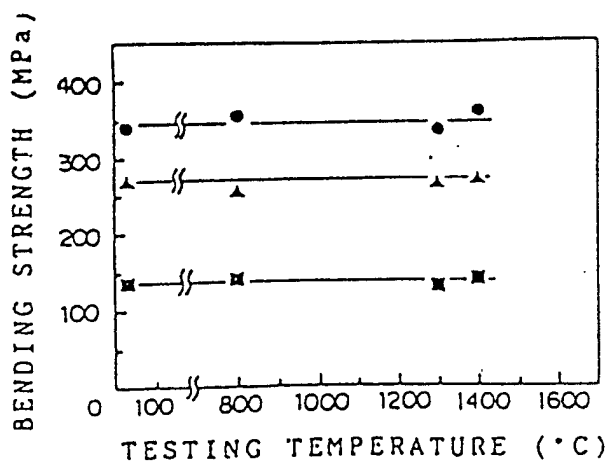

Figure 10. Heat-resistibility of CMC using Si-Ti-C-O fiber in air.

- ▲: UD sheet
- : plane web
- : UD sheet + powder

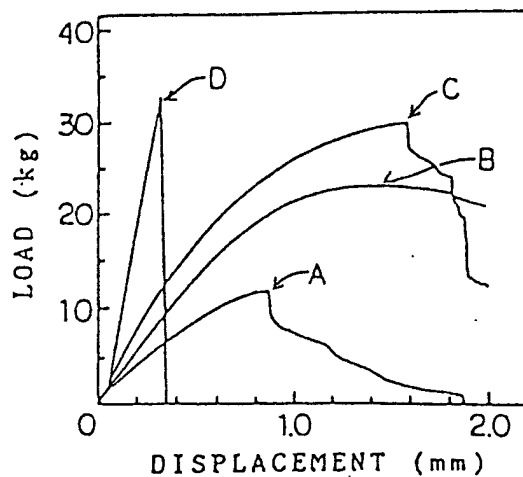

Figure 11. Load-displacement curve for CMC using Si-Ti-C-O fiber at 1400°C in air.

- A: plane web
- B: UD sheet
- C: UD sheet + powder
- D: Si-Ti-C-O powder

Overview of Pollution Control Biosensors

90FE0037 Tokyo JITA NEWS in Japanese 1 Feb 90 pp 16-25

[Article taken from Professor Suzuki's, Vice President, Saitama Institute of Technology, draft for his special lecture given at the 22nd Research Symposium on "Treatment and Analytical Technologies for Chemical Substances in Water," sponsored by the National Research Institute for Pollution and Resources at the Sankaido Ishigaki Memorial Hall on 12 July 1989]

[Text] 1. Introduction

The production of useful substances by biosynthesis and the development of water treatment processes through biological degradation have been undertaken in biotechnology by taking advantage of excellent metabolic functions of biological organisms or systems. The organisms also possess other superb functions of recognizing specific substances. It is possible to skillfully use these molecular recognition functions in analyzing specific chemical substances. Although enzymes, the biological catalysts, are widely used as analytical reagents, they require pre-analysis preparations and much time for analyses. Therefore, sensors have been developed to directly analyze target substances. The sensors use molecular recognition capable enzymes, antigens or antibodies, bonded proteins, organelles, microorganisms, or animal or plant tissues. However, because most of these materials are readily soluble in water, they are immobilized on a water-insoluble carrier to become molecular recognition-capable devices. Biosensors are constructed by combining one of these devices with one of electrochemical device, including electrodes and semiconductors, or photochemical devices such as optical diodes. Such biosensors are useful for analyses in industrial processes and the environmental field. In this paper, the principles and applications of biosensors will be discussed.

2. Principles of Biosensors

Biosensors consist of a molecular recognition-capable device, such as immobilized enzymes and immobilized microorganism, and electrodes.

Because of the enzymes' water insolubility, they are combined with a synthetic polymer film or a natural polymer film to form a device. Immobilization methods for enzymes will not be presented here, since they are discussed in detail in other books. An enzyme sensor can be actually produced by mounting an enzyme-immobilized film on an electrode. When this sensor is placed in a test solution containing a target chemical to be analyzed, enzymatic reactions will take place on the film. If there is the consumption or formation of a determinable electrode-active substance (a substance that can undergo reactions at the electrode), it will be determined directly at the electrode either as a current value or a voltage value, which can be in turn used as an index to calculate the quantity of the target chemical.

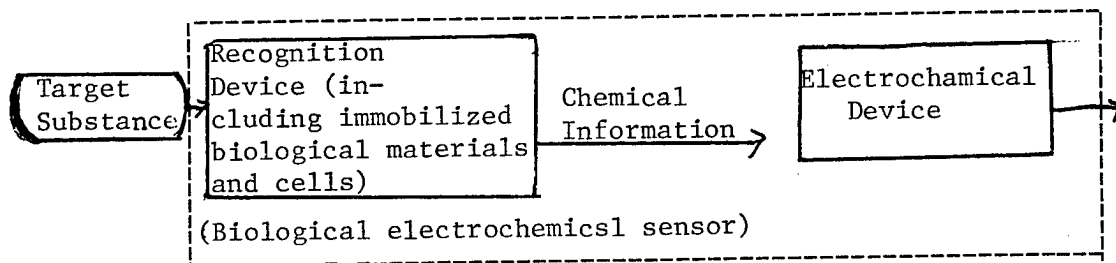

In this case, the enzyme film and the electrode function as a molecular recognition compartment and a transducer, respectively. The transducer converts signals to electric signals via either amperometry (current measurement method) or potentiometry (potential method). Amperometry is the method to obtain the concentration of a chemical from a current value used in direct electrode reactions by a reaction-participating substance. For this method, oxygen electrodes, hydrogen peroxide electrodes and fuel cell-type electrodes are used. Potentiometry is the method to obtain the concentration of ion or gas from membrane potential generated in the film that selectively senses the ion or gas. This method uses ion-selective electrodes and gas electrodes, involving ammonia or carbon dioxide.

The characteristics of a sensor is also determined by the combination of a molecular recognition-capable device and an electrode. The most basic type has the device mounted on the electrode surface, and this electrode is placed in test solutions. However, in order to be able to test many samples fast and reproducibly, a biosensor is set in a liquid-circulating cell. A buffer solution is transferred to the cell beforehand, and a test solution is poured into the system. The test solution is transferred to the sensor compartment by the buffer solution for the determination. A sensor of this type permits automatic cleaning of the electrode after each determination. There is another type that separates the molecular recognition-capable section and the electrode. For example, particulate

molecular recognition devices are packed in a mini-column which is then transferred to a buffer solution. When a sample is poured into the column, reactions will take place to produce an electrode-active substance. The buffer solution carries this substance to the electrode for determination. This type is used either when the reaction speed is slow or when the activity of the molecular recognition-capable substance is low.

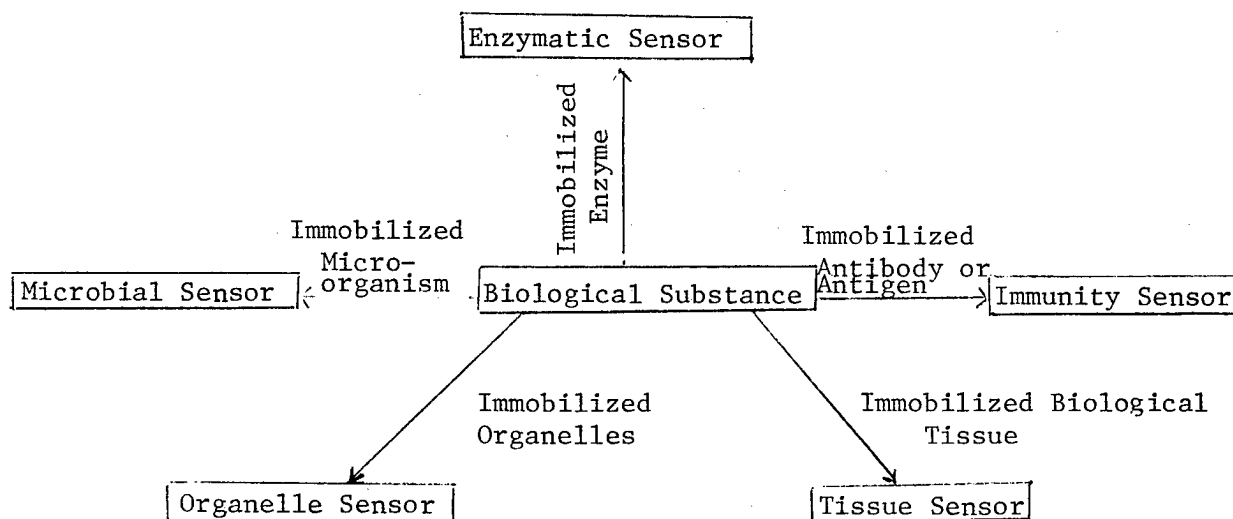

There are the equilibrium method and the rate method for the determination. The former determines the concentration of a target chemical from an equilibrium current value according to its relationships with the equilibrium potential value and the known chemical's concentration. The latter method determines the unknown concentration of a target chemical by the relationship between the rate change of either the potential value or the current value and the chemical concentration. When determinations are to be made by the liquid-circulating type system, a given amount of test solution is added to the system for a given length of time, so that reactions at the molecular recognition device never reach an equilibrium, yielding only fractions of equilibrium current or potential values. Thus, these cases are regarded as examples of the rate method.

The principles of the electrode-type biosensors have been discussed. However, because reactions at molecular recognition devices can also be sensed in the form of heat or light, these signals can be converted to electrical signals by a transducer such as a thermistor or a photon counter. Discussions here will be limited to the electrode-type biosensors.

Although the enzyme sensors should be discussed of all the biosensors, the enzyme sensors are used mainly in the medical and food fields and not necessarily in the water treatment field. Rather the microbial sensors are useful in water treatment. Thus, these sensors will be discussed here. Their principles and methodologies are generally the same as that for the enzyme sensors. In using microorganisms for a device, sometimes the functions of only one or more than one enzymes in an organism are used and in other times the entire physiological functions of an organism are utilized.

Microorganisms are classified roughly into two groups of aerobic and anaerobic. The aerobic organisms require oxygen for their existence and growth, and their activity can be traced through their breathing activity. On the other hand, the anaerobic organisms are a group of organisms that can survive without oxygen. Their activity can be followed by metabolites they produce.

A microbial sensor consists of a microorganism immobilization film and an electrochemical device. Microorganisms must be immobilized on a polymer film or in a polymer gel membrane by adsorption or inclusion to form a device. Because microorganisms, in many cases, are used for the sensor's device in their living form, mild methods of immobilization are generally used. These sensors are classified by the principle into the type (the breathing activity measuring type) using the breathing activity of microorganisms as the index and the type (the electrode-active substance measuring type) using a microbiologically metabolized electrode-active substance (an electrode-responding or reacting substance) as the index.

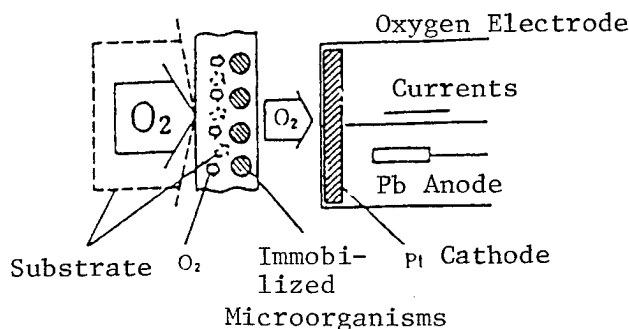

Figure 1. Breathing Activity Measuring-Type Microbial Sensor

The breathing activity measuring-type microbial sensor consists of a microorganism-immobilized film and an oxygen electrode or a carbon dioxide electrode. For example, live microorganisms are immobilized on a porous acetyl cellulose film by adsorption, and this film is mounted on an oxygen gas-permeable membrane of an oxygen electrode to produce a microbial sensor. When this microbial sensor is placed in a test solution containing an organic compound, the compound is dispersed in the microorganism film and is degraded (ingested) by the organism. As it decomposes the compound, the microorganism's breathing activity will show an increase which is detected by the oxygen electrode attached to the microorganism film. In other words, this microbial sensor can determine the concentration of the organic compound in the test solution, using the change in breathing quantity (measured as the difference in currents through the oxygen electrode) before and after the degradation of the organic compound as the index (Figure 1).

The microorganism produces many metabolites when it decomposes an organic compound. these metabolites include substances that readily react or show reaction at an electrode (electrode-active substances). Therefore, an electrode-active substance measuring-type microbial sensor can be built by combining an immobilized microorganism and any one of a fuel cell-type electrode, an ion-selective electrode and a gas electrode (Figure 2).

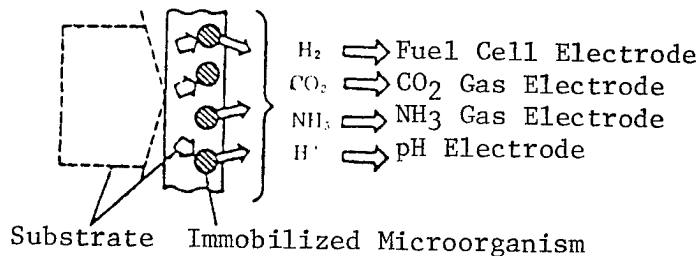
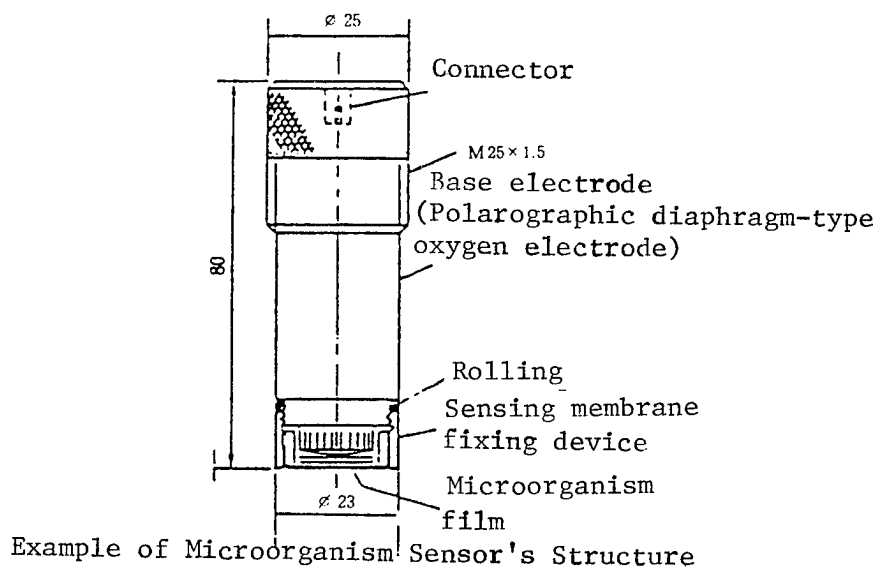

Figure 2. Electrode-Active Substance Measuring-Type Microbial Sensor

3. Structure of Microbial Sensor

A microbial sensor has a structure in which acetyl cellulose films, sandwiching microorganisms in between to prevent them from solubilizing out, are tightly mounted on the sensing membrane of a base electrode. An example of this sensor is shown in Figure 3.

For the base electrode, a polarographic diaphragm-type oxygen electrode is used for the breathing activity type sensor, and a pH electrode, hydrogen electrode, ammonia electrode or carbon dioxide electrode is used for the electrode-active substance type sensor. The reason for using the polarographic diaphragm-type oxygen electrode is to prevent potassium chloride solution inside the electrode from acting upon the microorganism or deteriorating the film in case the solution leaks out.



4. Measurement Method by Microbial Sensor

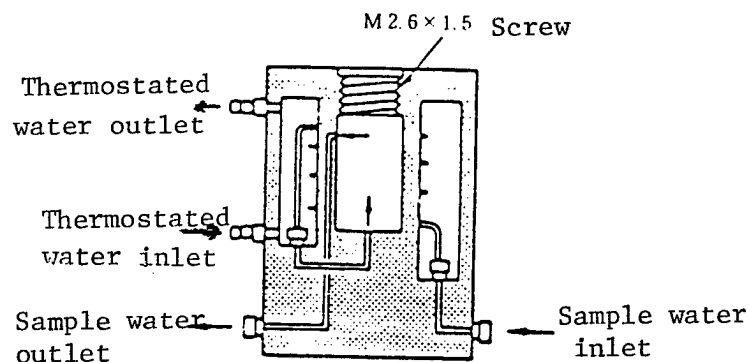

Figure 4. Design Example of Thermostated-Water-Jacketed Flow Cell

Although there are a beaker measurement method and a flow measurement method, the latter with a flow cell, as shown in Figure 4, is suitable for the measurement by a microbial sensor, because the activity of microorganism film can be maintained constant by the flow cell.

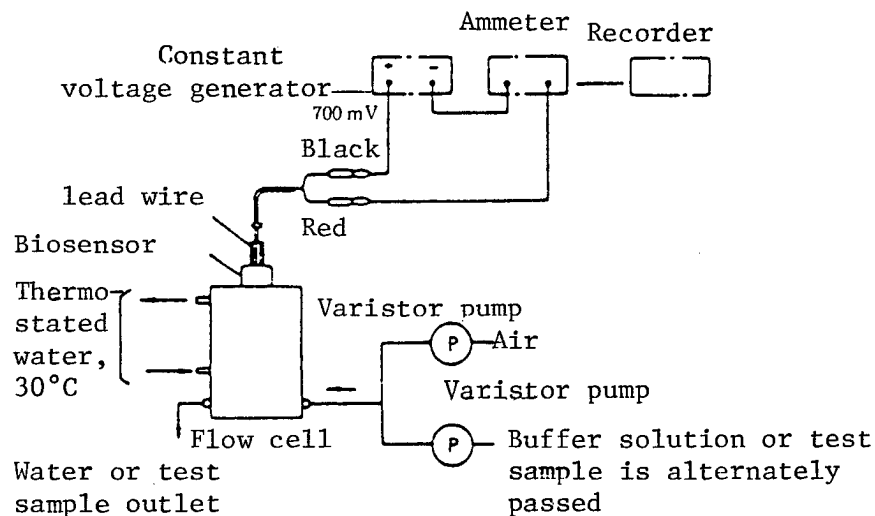

Figure 5. Microbial Sensor with Polarographic Diaphragm-Type Oxygen

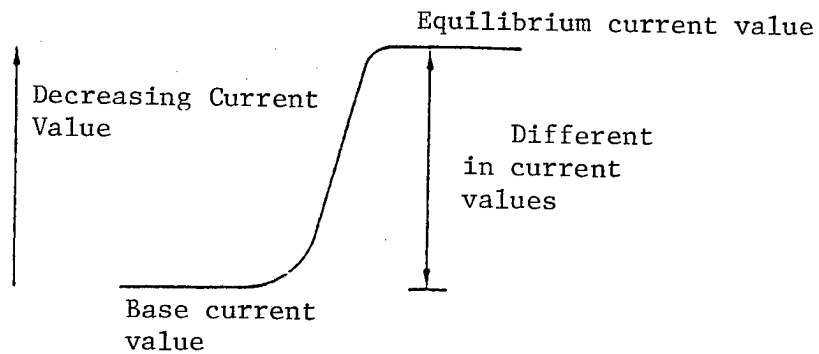

Figure 6. Response in Equilibrium Method

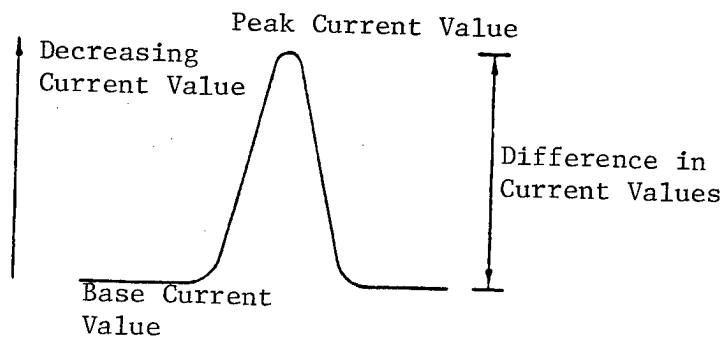

Figure 7. Response in Rate Method

The flow measurement mechanisms are shown in Figure 5. Measurements are always made with the saturation of soluble oxygen. First, a buffer solution is passed at a constant rate for a specified time to stabilize a base current value. Then, a sample is passed for a specified time, and a signal, shown in Figure 6, is obtained with the equilibrium method, or a signal, shown in Figure 7, is obtained with the rate method. The difference either between the base current value and the equilibrium value or between the base value and the peak value corresponds to the concentration of a target substance. Similarly, if a calibration curve

has been prepared with two or three different concentrations of a standard solution, the concentration of the target substance can be read from the calibration curve. However, because it is troublesome to measure the difference above the base current value each time, these measurements are, in practice, often made semiautomatically by a measurement system.

5. Kinds of Microbial Sensors

Table 1. Characteristics of Microbial Sensors

Sensor	Innobilized Microorganism	Electrode	Measurement Range	Response Time (minute)	Stable Period (day)
Amperometric Method					
Glucose	<i>Pseudomonas fluorescens</i>	Oxygen electrode	3 - 20	10	14
Degraded saccharides	<i>Brevibacterium lactofermentum</i>	Oxygen electrode	20 - 200	10	20
Acetic acid	<i>Trichosporon brassicae</i>	Oxygen electrode	10 - 200	15	30
Ammonia	<i>Nitrobacter bacterium</i>	Oxygen electrode	3 - 45	5	20
Methanol	Bacterium to be identified	Oxygen electrode	3 - 22	15	30
Ethanol	<i>Trichosporon brassicae</i>	Oxygen electrode	3 - 30	15	30
(Nystein)	<i>Saccharomyces cerevisiae</i>	Oxygen electrode	1.2-800	60	-
Mutagen	<i>Bacillus subtilis</i>	Oxygen electrode	1 - 100	60	-
BOD	<i>Trichosporon cutaneum</i>	Oxygen electrode	3 - 30	10	30
Bacteria count	-	Fuel cell	10 ⁶ - 10 ^{11a)}	15	60
Vitamin B ₁	(<i>Lostridium butyricum</i>)	Fuel cell	10 ⁻³ - 10 ⁻²	360	60
Formic acid	<i>Clostridium butyricum</i>	Fuel cell	1 - 1,000	10	30
Potentiometric Method					
Cephalosporin	<i>Citrobacter freundii</i>	pH electrode	60 - 500	10	7
Nicotinic acid	<i>Lactobacillus arabinosus</i>	pH electrode	10 ⁻² - 5	60	30
Glutamic acid	<i>Escherichia coli</i>	CO ₂ electrode	8 - 800	5	20
Lysine	<i>Escherichia coli</i>	CO ₂ electrode	10 - 100	5	20

a) Bacteria count/ml

Table 1 lists the characteristics of microbial sensors that have thus far been developed. Microbial sensors are highly stable for a long period, and those sensors used for determining ethyl alcohol, acetic acid, glutamic acid and BOD are in practical use and some of them are commercially available.

6. Microbial Sensors for Environmental Monitoring

Commonly, microorganisms and plants, including lichens, are used as environmental indices. However, their reactions are slow and do not necessarily express quantitatively with ease and accuracy. Microbial sensors take advantage of the organism's living conditions, and the organisms are actually living in a immobilization film for a long time. Therefore, it is possible to use them for continuously monitoring environments. In other words, because the action of a chemical substance upon a microorganism can be read as a direct signal, measurements can be done extremely fast.

6.1 BOD Sensors

According to the JIS K 0102, the BOD (biological oxygen demand), an index for water pollution, is to be determined as a microbially-degradable organic matter content. It requires complicated procedures and five days to determine this quantity. Thus, a simpler and faster method has been needed, and a BOD microbial sensor has been developed in response to this need. In contrast to other microbial sensors using microbes that selectively degrade a target substance, a BOD sensor uses *T. cutaneum*, a yeast fungus, that degrades, without selectivity, as many a variety of organic matters as possible. The sensor has a microbe-immobilizing polyethylene mesh, that makes direct contact with sample solutions. A linear relationship exists between BOD concentrations, less than 600 mg/l, and current values (Figure 8). The sensor's response time is approximately 15 minutes with the equilibrium method, requiring 30 minutes to make one determination, although the time can be reduced to 20 minutes with the rate method. As mentioned earlier, this sensor uses the type of microbe that degrades many organic matters, although it does not necessarily degrade all organic matters. Results of comparison between this sensor and the JIS method are given in Figure 9 using pure reagents of an amino acid, acetic acid, glucose and aniline. The graph shows that *T. cutaneum* efficiently degrades amino acids, saccharides and low-carbon fatty acids, and degrades aromatic compounds, such as aniline, with difficulty. Furthermore, because the microbe is fixed inside a hydrophilic cellulose film with a pore size of 0.45 μm , any organic matters larger than 0.45 μm cannot be detected by this sensor. Thus, this sensor can be said to be made for soluble organic matters. The sensor's reproducibility was checked with a BOD concentration of 48 mg/l to find a relative error of 2.02 percent after 10 determinations. When compared with the JIS method in determining a BOD reading of a food plant effluent, a correlation coefficient of 0.9100 and a regression equation, $y = 0.88x + 41.43$ were obtained, and it was confirmed that the sensor method agreed well with the JIS method (Figure 10).

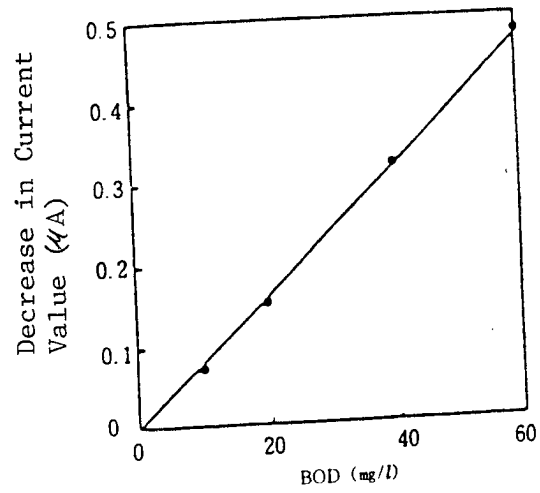

Figure 8. Calibration for BOD Sensor

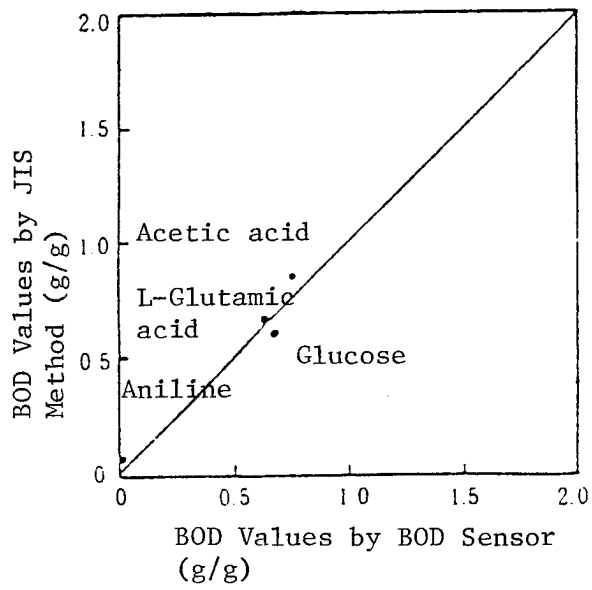

Figure 9. Comparison of Sensor Method and JIS Method with BOD Values of Pure Organic Compounds

The activity of the microbial film did not decrease six months after its preparation.

Recently, a soluble BOD rapid determination system with a microbial sensor has been put to practical use. The principle of this system, as mentioned before, is that, when the *T. cutaneum*-immobilized film makes contact with a waste water sample, this yeast fungus depletes oxygen as it degrades organic matters, decreasing the concentration of oxygen reaching an oxygen electrode. Because this drop in the oxygen concentration is proportional to the concentration of the organic matters, the apparent BOD concentrations of the sample can be continuously determined. The composition of this system is illustrated in Figure 11.

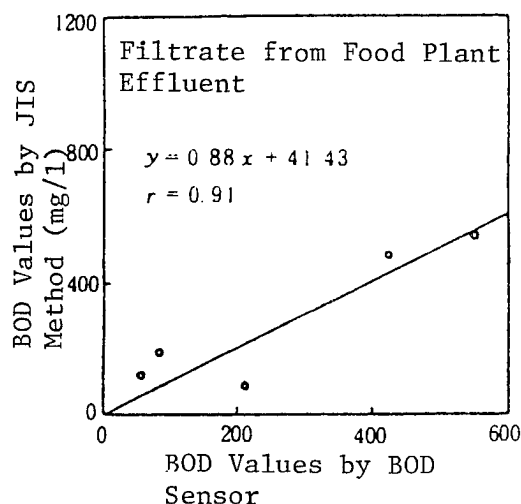

Figure 10. Relationship between Two Sets of BOD Values for Filtrate from Food Plant Effluent as Determined by Microbial Sensor and by JIS Method

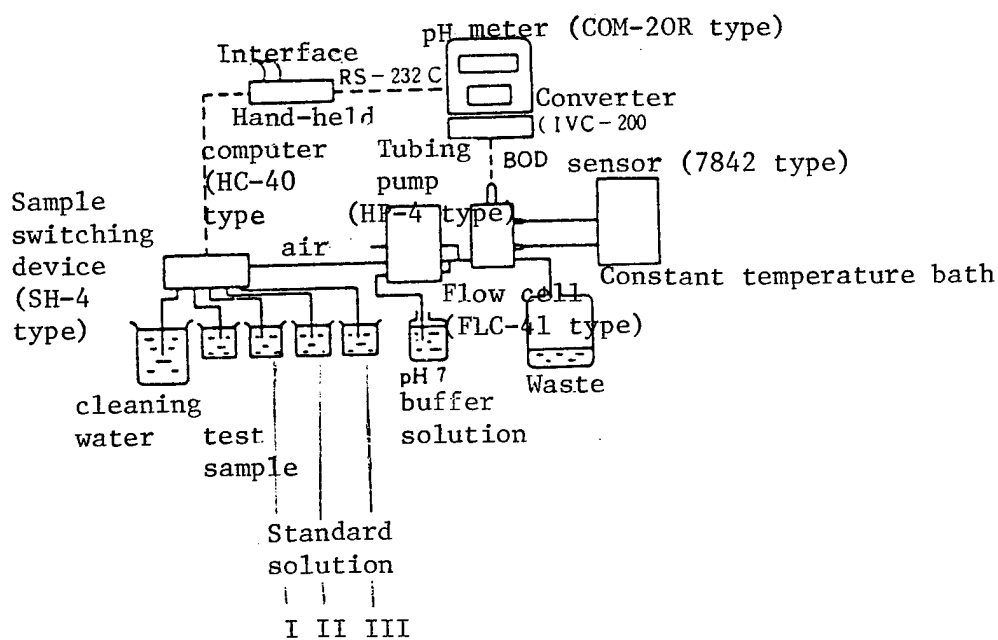

Figure 11. System Composition Diagram

As can be seen in the system composition diagram, the determinations are made by the flow analysis with a BOD sensor. Therefore, the analytical conditions are steady, the operation is simple and fast, requiring only approximately 20 minutes to print out a BOD concentration. It is also easy to process data with an interface-attached, table-top pH meter. The sensor's base electrode is a diaphragm-type oxygen electrode, that provides a stable structure against dirt admixed in waste water. The operational conditions for this system are five minutes for sampling, 15 minutes for cleaning, a flow rate of 6.3 ml/min and a temperature of $30 \pm 0.2^\circ\text{C}$. Although it depends on the operational conditions, an optimal range of analytical capabilities is 0 to 80 mg/l in BOD concentration. One example of repeated experiments is shown below.

Sample Concentration	44 mg/l
First determination	44.9
Second	43.7
Third	44.3
Fourth	46.5
Fifth	45.2
Sixth	44.9
<hr/>	
Average	44.6

Although this microbial sensor is highly useful for simple determinations of soluble BOD, it is important to clarify any discrepancies with BOD values determined by the official JIS method. Strictly speaking, it is unavoidable to see some difference because the sensor uses a specific microbe that is different from microflora in sludge. However, according to the results of numerous experiments conducted thus far, it has been empirically proven that there is a comparatively good relationship between the microbial sensor values and the JIS method values. A comparison of the two sets of values is given in Table 2.

Table 2. Comparison of Electrode Method and Previous Method

Table 2. Comparison of Electrode Method and Previous Method

Substrate	BOD Values (g/g)		A/B	Group
	(A) Electrode Method	(B) Previous Method		
		() denotes no. of days		
Lactose	0.06	0.45 - 0.72 (5)	0.08-0.13	1
Soluble starch	0.07	0.22 - 0.71 (9)	0.10-0.32	
Lactic acid	0.17	0.40 (1)	0.43	
Sucrose	0.36	0.49 - 0.76 (6)	0.47-0.73	2
Histidine	0.35	0.55 (1)	0.64	
Glycerol	0.51	0.62 - 0.83 (7)	0.61-0.82	
Fructose	0.54	0.71 (1)	0.76	
Glycine	0.45	0.52 - 0.55 (2)	0.82-0.87	
Lactic acid	0.72	0.63 - 0.88 (3)	0.82-1.14	
Glutamic acid	0.70	0.64 (1)	1.09	
Glycose	0.72	0.50 - 0.78 (12)	0.92-1.44	
Ethyl alcohol	2.90	0.93 - 1.67 (14)	1.74-3.12	3
Acetic acid	1.77	0.34 - 0.88 (9)	2.01-5.21	

As seen in this table, the comparison values (A/B) for ethyl alcohol and acetic acid are high, because these substances can be readily degraded by microorganisms used in the sensors. On the other hand, lactose and soluble starch show low values. However, most of the organic compounds shown in Table 2 are comparatively readily degradable, so that their comparison values are excellent. Therefore, BOD determinations for most organic waste water can be made regularly as long as no extreme change occurs in the water composition, although the determination depends upon the kinds of organic compounds present. The main issue is to be able

to quickly realize approximately what levels of BOD concentration the currently flowing waste water has. Even though the JIS method is the official method, it is a unique analytical method, not necessarily based on stoichiometry. Moreover, it takes at least five days to complete a determination with this method, and it requires mastery of the procedures. Considering all these factors, the microbial sensor is simple to operate, and once made and used, it is relatively stable and will permit continuous determinations for a long time, proving its usefulness as a monitor. Since many data and much know-how have been accumulated on the sensor, it should hopefully be widely used in water treatment processes.

6.2 Nitrite Ion Sensor

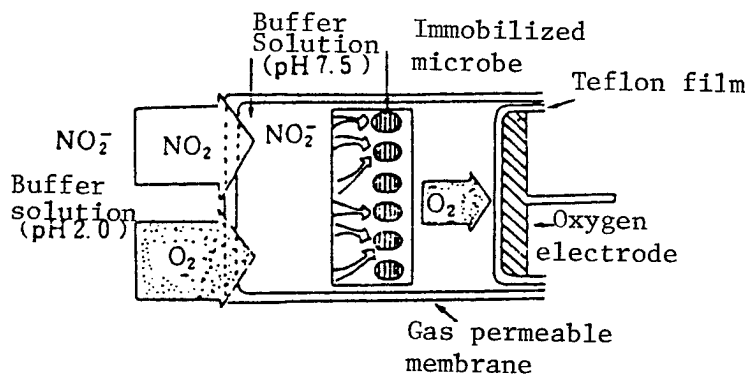

Figure 12. Principle of Nitrite Ion Sensor

This sensor is needed for simple determinations to check water quality, manage sewer treatment processes and diagnose soil conditions. The microbe used for this sensor is *Nitrobacter* sp., the same one used for the ammonia sensor. The bacteria cultivation and the sensor production are done in exactly the same manner as for the ammonia sensor. The principle is shown in Figure 12, and a system using the sensor is illustrated in Figure 13.

Nitrite ion is converted to gaseous nitrogen dioxide in the buffer solution (pH 2). The gas permeates through the gas permeable membrane, and the gas is reverted to nitrite ion within the immobilized microbial film (pH 7.5). When this nitrite ion is ingested by *Nitrobacter* bacteria, oxygen is consumed. The amount of oxygen consumption is measured in terms of the current value by the teflon-covered oxygen electrode. As shown in Figure 14 [TN: 13], the measurement system allows continuous measurements by constantly pumping the test solution through the flow cell at a rate of 1.6 ml/min and at a sensor temperature maintained at $30 \pm 1^\circ\text{C}$.

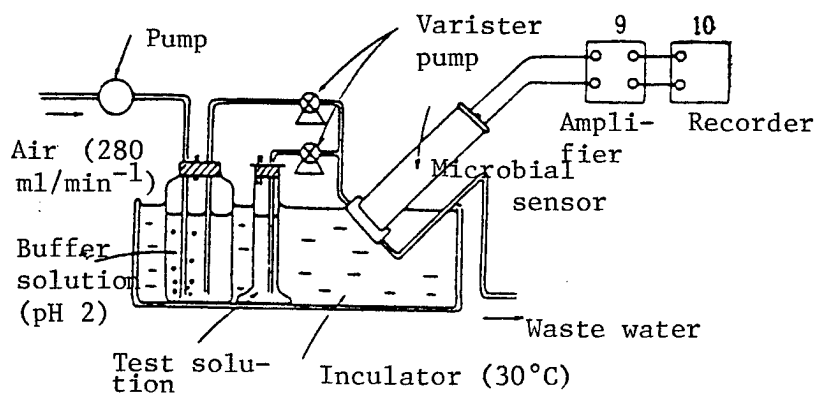

Figure 13. Measurement System Diagram

As Figure 14 shows, a linear relationship is obtained between the current value decrease and the nitrite ion concentration in a nitrite ion concentration range up to 0.6 mM.

The analytical limit for this sensor was $10 \mu\text{M}$, its reproducibility was within ± 4 percent, and the standard deviation was $10 \mu\text{M}$. No interference was observed on the selectivity of this sensor by metal ions, such as iron and copper, as well as urea and ammonium ion. This excellent selectivity of this sensor is due to the gasification of nitrite ion at pH 10 for measurements. This sensor was used for 400 measurements in 21 days without any decrease in current values, proving the sensor's extremely high stability. Incidentally, for reference, measurement results by this method and by the JIS method are compared in Figure 15.

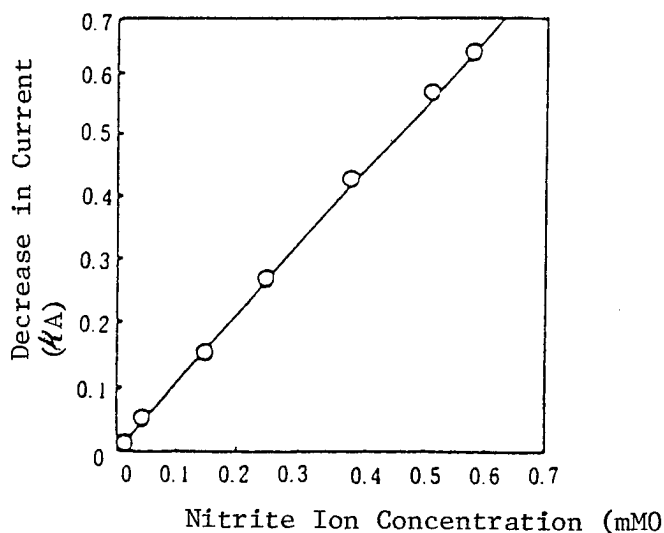

Figure 14. Calibration Curve for Nitrite Ion Sensor

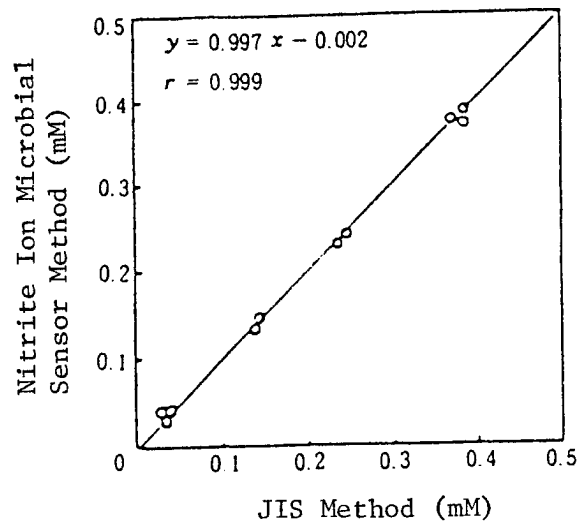
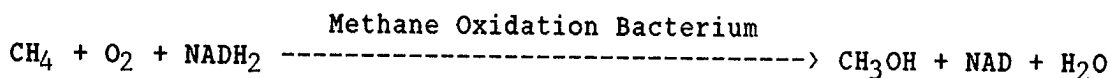

Figure 15. Comparison of Nitrite Ion Determinations by JIS Method and by Microbial Sensor

6.3 Methane Sensor

The production of methane gas from organic waste water is one of the important topics on the effective utilization of waste water. A gas sensor using a semiconductor device has been actually used as a methane gas sensor. The author's group selected *Methylomonas* sp. for the methane oxidation bacteria with high target specificity for our methane sensor. This microbe oxidizes only methane to use it as a carbon source and an energy source.



The sensor's principle is diagrammed in Figure 16.

The methane oxidation bacteria had been cultured for collection for the sensor.

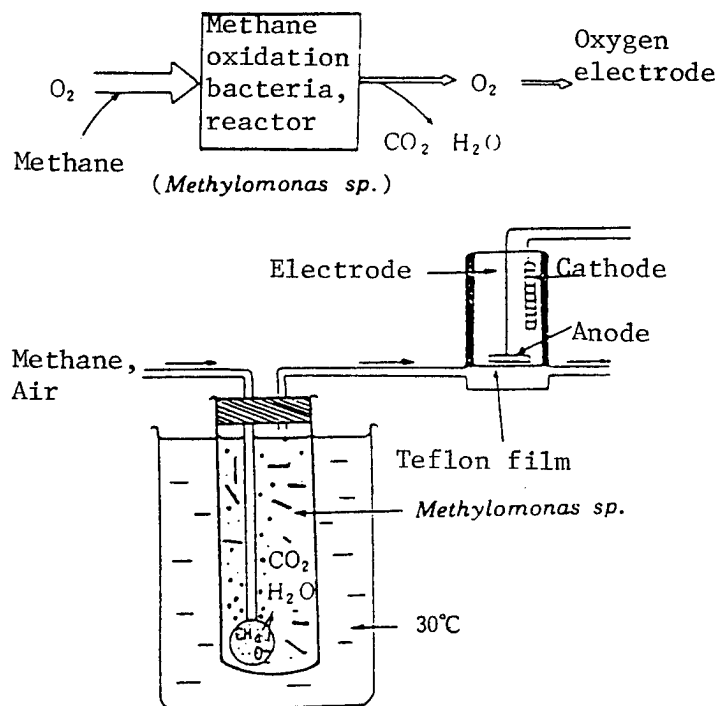
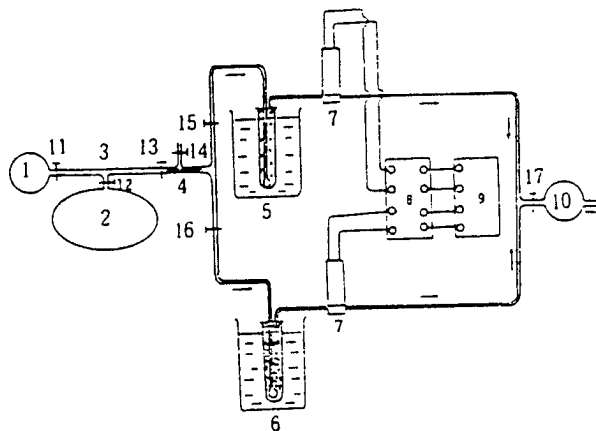

Figure 16. Methane Sensor

A suspension of these bacteria and an acetyl cellulose filter membrane were added to an agar-agar solution (50°C) and rapidly cooled to 30°C to obtain a methane oxidation bacteria-immobilized acetyl cellulose filter membrane. A measurement system is illustrated in Figure 17. This system consists of two reactors and two oxygen electrodes. The above-described immobilized methane oxidation bacteria were packed in one of the reactors. In the other reactor, which is the control reactor, the identical acetyl cellulose filter membrane without the methane oxidation bacteria is packed. Methane gas was sent into the reactors by a pump. Methane is oxidized in the reactor containing the methane oxidation bacteria, and a portion of oxygen in a test gas is consumed.

No oxygen is consumed in the control reactor where no bacteria are contained. Two different flows of the test gas are led from the two reactors to two different oxygen electrodes for separate oxygen content determinations.



- | | |
|---------------------------------------|---------------------|
| 1. Pump | 7. Oxygen electrode |
| 2. Test gas | 8. Amplifier |
| 3. Sampler | 9. Recorder |
| 4. Cotton filter | 10. Pump |
| 5. Control reactor | 11-17. Valves |
| 6. Methane oxidation bacteria reactor | |

Figure 17. Methane Measuring System

A methane calibration curve, as shown in Figure 18, was obtained by using standard methane gas. A linear relationship was obtained between the current value and the methane concentration up to a methane concentration of 6.6 mM. Furthermore, the methane concentrations of sample gases were determined by using this sensor and the chromatographic method. When the two sets of data were compared, they agreed very well with a correlation coefficient of 0.97, as shown in Figure 19. The lower limit of methane concentration that can be determined by this sensor was 1 μ M. In addition, after used for more than 500 determinations in 20 days, this sensor did not show any lowering of current values, as shown in Figure 20, proving its stability for a long period.

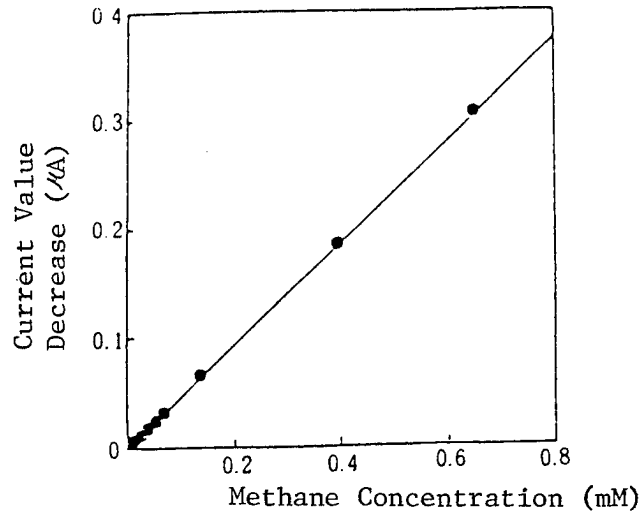

Figure 18. Methane Calibration Line

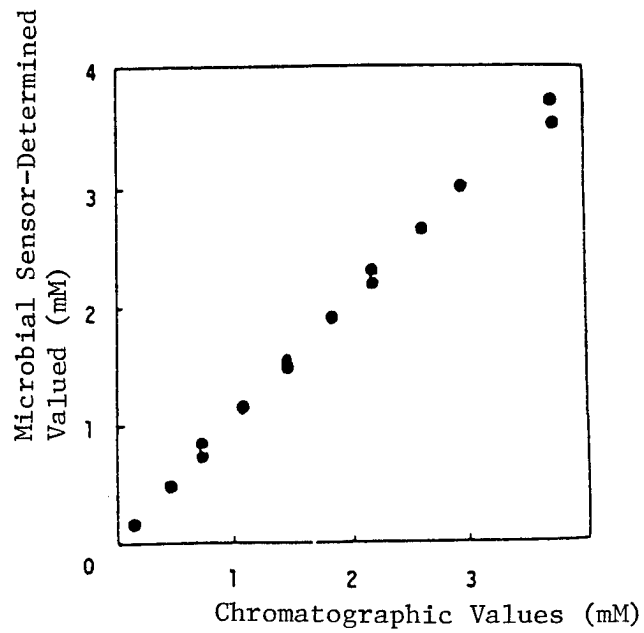
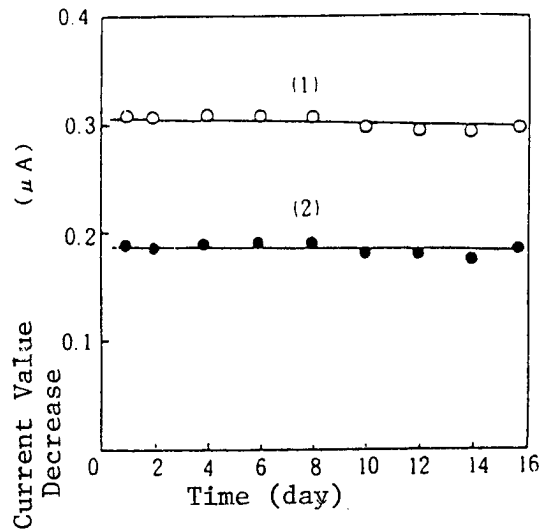

Figure 19. Comparison of Microbial Sensor and Gas Chromatography



(1) Figure 20. Reproducibility of Methane Sensor: at methane concentrations of 0.66 mM for Curve (1) and 0.39 mM for Curve (2)

7. Conclusion

The key points were discussed concerning the microbial sensors, one type of biosensors, and their applications, particularly related to the water treatment processes. Hopefully, the various characteristics of the microbial sensors were clarified, although there are still problems to be solved. However, because of their inexpensive and simple construction, further expansion of application is expected for them. In particular, it is our sincere hope that the microbial sensors be used for determining organic matters and BODs in the water treatment processes.

Nuclear Power Public Opinion Poll Released

90CF0358A Tokyo GENSHIRYOKU SANGYO SHIMBUN in Japanese 25 Jan 90 p 6

[Text] The Trend of Public Opinion on Nuclear Power: From the Report of the Energy and Information Sciences Research Council

Great Expectations of Nuclear Power; Also Great Concern About the Global Environment

The Energy and Information Sciences Research Council (Tadashi Mukaibo, Managing Director), on the 19th, announced that it had compiled the results of its public opinion survey on energy and nuclear power, as well as an international comparison. According to this survey, concern is high in Japan about energy supply and demand and the global environment question. With regard to nuclear power plants, the expectations of nuclear power are the highlight, and well over half of the nation considers nuclear power to be necessary. In particular, the residents of areas near nuclear power plant sites have a high awareness of nuclear power and energy, including an accurate knowledge base. Below we present an outline of this report.

High Concern Over Energy

Ninety percent of the nation has some sort of concern about energy. This figure is practically the same for those living near nuclear plant sites, with 92 percent concerned about energy. However, in contrast to the 34 percent nationwide who "are extremely concerned," 42 percent of those near a site share the same attitude. Hence, the concern of those people living near sites can be said to be a little stronger.

Ninety-five percent of the nation is concerned about the global environment question in some form or other, and this is virtually the same for those living near sites at 96 percent.

Moreover, with regard to the need to cooperate on the global environment question, 80 percent of the entire nation believes that "there is a need to cooperate across-the-board," whereas 77 percent of those living near a site believe in such a need. If we add the percentage of people who agree that "there is some need," then 99 percent of everyone both nationwide and living at a site think that there "is a need to cooperate" in some form or other.

With regard to energy self-sufficiency (19.9 percent in 1986), the percentage who answered correctly and said "between 10 and 20 percent" was 29.3 percent nationwide and 26.1 percent for those persons living at sites. Less than 30 percent of each group has an accurate knowledge of Japan's energy self-sufficiency. If we take "between 10 and 20 percent" as the center and account for the percentage of people who were close to having a correct understanding of energy self-sufficiency and answered from "less than 10 percent" to "between 20 and 30 percent," we find that 73.5 percent of the nation and 65 percent of those persons living near nuclear sites answered within that range. Hence, it can be said that the nation as a whole has a more accurate awareness than the people living near nuclear sites of the nation's self-sufficiency.

In addition to this, with regard to the question of whether Japan's energy demands will increase over the next 10 years, 90 percent of the entire nation and 86 percent of those persons living near a site answered in the affirmative that "energy demand will increase." Conversely, only 6 percent of the populace nationwide and 8 percent of those living near nuclear sites thought that "demand will decline."

The nation and persons living near nuclear sites are in complete accord that "energy demand will increase" as a forecast for energy demand over the next 10 years.

Besides this, with regard to the standard of living and energy, 48 percent of the nation and 50 percent of those people near nuclear sites, or about half in each category, believe that "an increase in energy consumption is unavoidable in order to raise the standard of living."

On the other hand, persons who say that "even if the quality of life declines, we want to reduce energy consumption" amount to 27 percent nationwide and 25 percent of persons living near nuclear sites. Moreover, the percentage of people who believe that "the present level is good" is 3 percent in every category.

Ninety or close to 90 percent of both the nation and people living near nuclear sites believe that, with regard to the forecast of an increase in Japan's energy demand, the demand for energy will "increase." However, only about half of nation believes that "energy consumption will increase" in terms of their own energy consumption in their daily lives. In comparison with the macro forecast of energy demand, the micro intentions of energy consumption are practically half.

High Support From Those Living Near a Nuclear Site

Moreover, as far as useful future sources of energy are concerned, "sunlight" took first place with 59.1 percent, and "nuclear power" took second place with 44 percent. For persons living near a nuclear plant site, 51.0 percent mentioned "nuclear energy" and 47.3 percent mentioned "sunlight." The order of "nuclear energy" and "sunlight" changes places.

As part of the energy mix, 60 percent of the nation and 67 percent of those people living near a nuclear plant site believe that "the necessity of nuclear power will increase." Slightly more people living near nuclear plant sites forecast the "need for nuclear energy."

Conversely, 21 percent of the nation and 20 percent of those people living near a nuclear plant site believe that "the need will not increase," virtually the same percentage for each group.

With regard to the question of what source of power is the main source of electricity at present, 59.4 percent of the nation, or close to 60 percent, answered correctly that it was "oil-generated thermal power," whereas 44.3 percent of those living near nuclear plant sites, or less than half, provided the same answer.

On the other hand, the percentage of people who believe that it is "nuclear energy" are 20.8 percent nationwide, and 32.8 percent of those who live near nuclear plant sites.

Similarly, 12.6 percent nationwide responded that the main power source was "hydroelectric power," whereas 18.9 percent of those living near nuclear plant sites gave the same response. In both this case and the above, those living near sites were a higher percentage.

With regard to the important energy source over the next 10 years, 51 percent nationwide and 62.3 percent of those living near nuclear plant sites named "nuclear power-generated electricity." Compared with the nation overall, more people living near nuclear plant sites named "nuclear power-generated electricity."

Moreover, the percentage nationwide that believed that "oil-generated thermal power" would be the main energy sources 10 years from now was only 15.7 percent.

On the other hand, when asked about "the useful energy in the future," 15.9 percent of the nation responded that it would be "sunlight-generated electricity." Of persons living near nuclear plant sites, 11.7 percent forecast this as an important energy source, or somewhat less than nationwide.

Twenty-nine percent of the respondents nationwide answered that nuclear energy would be "extremely important" when asked about the extent that nuclear energy would be important in meeting Japan's future electricity demand. In contrast, 35 percent of those living near nuclear plant sites gave the same answer. Also, 44 percent nationwide and 45 percent of those living near nuclear plant sites said that nuclear energy would be "important to some extent."

When we combine "extremely important" and "important to some extent," we find that 73 percent nationwide and 80 percent of those persons living near nuclear plant sites are pro-nuclear energy. Half of the people

believe that nuclear energy is important, and those living near a nuclear plant site are only slightly more positive than the nation as a whole.

On the other hand, 14 percent of the nation believes that it is "not too important," and 12 percent of those living near nuclear power sites believe the same thing. Seven percent of the entire nation believes that nuclear power is "completely unimportant," and 5 percent of those living near nuclear power plant sites believe the same thing. Putting these two views together, the percentage of the anti-nuclear energy population is 21 percent for the nation and 17 percent for those living near nuclear plant sites.

Television and Newspapers Are the Main Sources of Nuclear Energy Information

More than 80 percent of both the nation and persons living near nuclear plant sites state that they obtain from "television" and "the newspapers" their information on energy and nuclear energy. In particular, the percentage across the nation obtaining information on energy is more than 90 percent at 93.7 percent.

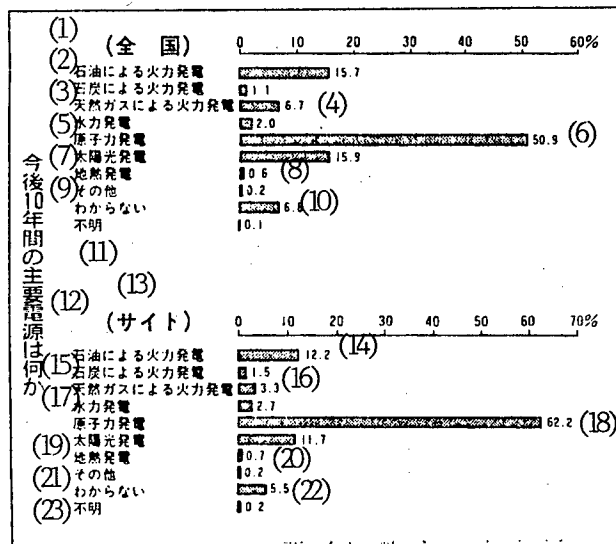

Fig. 1 What Will Be the Major Energy Source Over the Next Ten Years?

Key:

1. (Nationwide)
2. Thermal-generated electricity by oil 15.7 percent
3. Thermal-generated electricity by coal 1.1 percent
4. Thermal-generated electricity by natural gas 6.7 percent
5. Hydroelectric power 2.0 percent
6. Nuclear energy generated power 50.9 percent
7. Sunlight generated power 15.9 percent
8. Geothermal generated power 0.6 percent
9. Other 0.2 percent

[Key continues on following page]

[Key continues]

10. Do not know 6.8 percent
11. Unclear 0.1 percent
12. What will be the major energy source over the next ten years?
13. ([Persons living near a nuclear plant] site)
14. Thermal-generated electricity by oil 12.2 percent
15. Thermal-generated electricity by coal 1.5 percent
16. Thermal-generated electricity by natural gas 3.3 percent
17. Hydroelectric power 18.0 percent
18. Nuclear energy generated power 32.8 percent
19. Sunlight generated power 0.2 percent
20. Geothermal generated power 0.0 percent
21. Other 0.0 percent
22. Do not know 1.0 percent
23. Unclear 0.0 percent

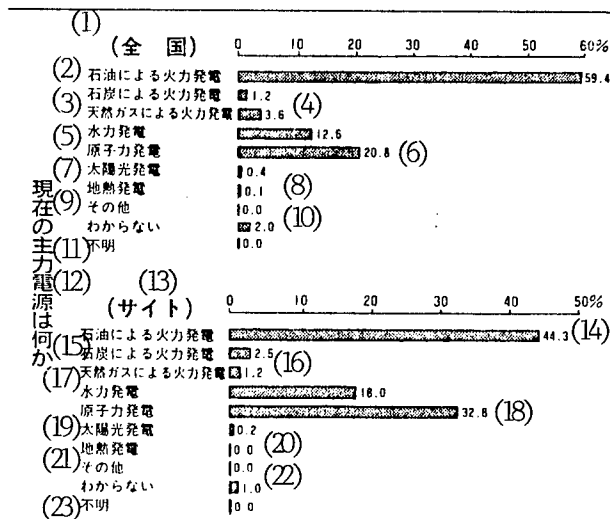

Fig. 2 What Is the Present Chief Source of Energy?

Key:

1. (Nationwide)
2. Thermal-generated electricity by oil 59.4 percent
3. Thermal-generated electricity by coal 1.2 percent
4. Thermal-generated electricity by natural gas 3.6 percent
5. Hydroelectric power 12.6 percent
6. Nuclear energy generated power 20.8 percent
7. Sunlight generated power 0.4 percent
8. Geothermal generated power 0.1 percent
9. Other 0.0 percent
10. Do not know 2.0 percent

[Key continues on following page]

[Key continues]

11. Unclear 0.0 percent
12. What is the present chief source of energy?
13. ([Persons living near a nuclear plant] site)
14. Thermal-generated electricity by oil 44.3 percent
15. Thermal-generated electricity by coal 2.5 percent
16. Thermal-generated electricity by natural gas 1.2 percent
17. Hydroelectric power 2.7 percent
18. Nuclear energy generated power 62.2 percent
19. Sunlight generated power 11.7 percent
20. Geothermal generated power 0.7 percent
21. Other 0.2 percent
22. Do not know 5.5 percent
23. Unclear 0.2 percent

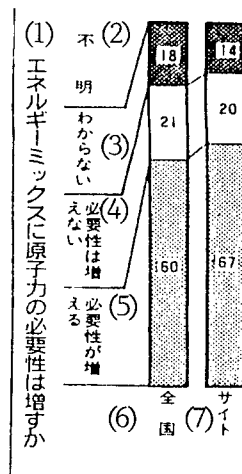

Fig. 3 Will the Need for Nuclear Power in the Energy Mix Increase?

Key:

1. Will the need for nuclear power in the energy mix increase?
2. Uncertain
3. Do not know
4. The need will not increase
5. The need will increase
6. Nationwide
7. [Persons who live near a nuclear plant] site

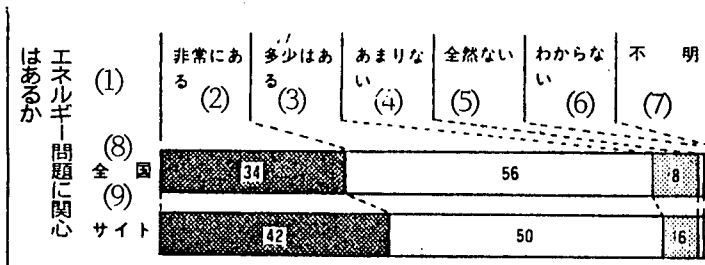

Fig. 4 Are You Concerned About the Energy Problem?

Key:

1. Are you concerned about the energy problem?
2. Extremely concerned
3. Somewhat concerned
4. Not very concerned
5. Absolutely not concerned
6. Do not know
7. Unclear
8. Nationwide
9. [Persons living near a nuclear plant] site

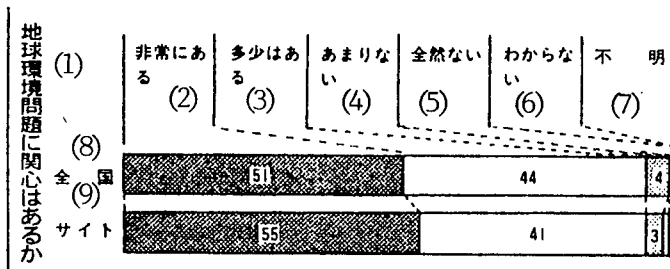

Fig. 5 Are You Concerned About the Global Environment Problem?

Key:

1. Are you concerned about the global environment problem?
2. Extremely concerned
3. Somewhat concerned
4. Not very concerned
5. Absolutely not concerned
6. Do not know
7. Unclear
8. Nationwide
9. [Persons who live near a nuclear plant] site

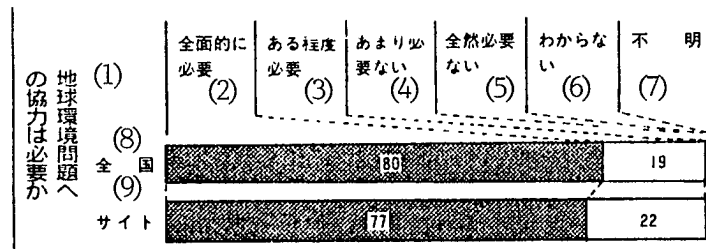

Fig. 6 Do We Need Cooperation on the Global Environment Question?

Key:

1. Do we need cooperation on the global environment question?
2. Needed across-the-board
3. Needed to a certain extent
4. Not very necessary
5. Absolutely unnecessary
6. Do not know
7. Unclear
8. Nationwide
9. [Persons who live near nuclear plant] sites

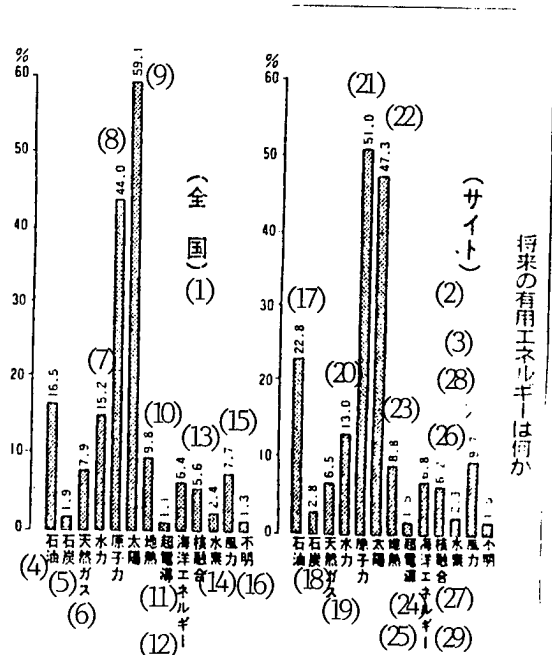

Fig. 7 What Will Be the Useful Energy of the Future?

Key:

- | | |
|---|---------------------------------|
| 1. (Nationwide) | 15. Wind power 7.7 percent |
| 2. ([Persons who live near a nuclear plant] site) | 16. Unclear 1.3 percent |
| 3. What will be the useful energy of the future? | 17. Oil 22.8 percent |
| 4. Oil 16.5 percent | 18. Coal 2.8 percent |
| 5. Coal 1.9 percent | 19. Natural gas 6.5 percent |
| 6. Natural gas 7.9 percent | 20. Hydropower 13.0 percent |
| 7. Hydropower 15.2 percent | 21. Nuclear energy 51.0 percent |
| 8. Nuclear energy 44.0 percent | 22. Solar 47.3 percent |
| 9. Solar 59.1 percent | 23. Geothermal 8.8 percent |
| 10. Geothermal 9.8 percent | 24. Superconductors 1.5 percent |
| 11. Superconductors 1.1 percent | 25. Marine energy 6.8 percent |
| 12. Marine energy 6.4 percent | 26. Nuclear fusion 6.2 percent |
| 13. Nuclear fusion 5.6 percent | 27. Hydrogen 2.3 percent |
| 14. Hydrogen 2.4 percent | 28. Wind power 9.7 percent |
| | 29. Unclear 1.5 percent |

MPT Report on ISDN Terminal Connectivity Described

43063821 Tokyo ISDN TANMATSU NADO NO SOGO SETSUZOKUSEI, SOGO UNYOSEI NO KOJO NI KANSURU GAIDORAIN in Japanese 1989 pp 1-6

[This document consists of the guideline entitled "Guideline for Improvements of Interconnectivity and Interoperability of ISDN Terminals, Etc," and the "Description" as a preface to the guideline.]

[Text] Description of "Guideline for Improvements of Interconnectivity and Interoperability of ISDN Terminals, Etc."

Background to announcement of "Guideline"

In parallel with the arrangement of ISDN (Integrated Digital Services Network), the standardization activities of various telecommunications systems providing telecom services are progressing energetically.

Consequently, it is more necessary than ever to confirm the mutual connectivity and operation of systems from various manufacturers developed based on the new standards. Under the contacts and arrangements with the "Harmonization of Advanced Telecommunication Systems Development Conference" (HATS Development Conference) held by the Ministry of Posts and Telecommunications [MPT], several testing groups have organized on a voluntary basis to conduct connectivity testing.

Meanwhile, current connectivity testing systems based on such an ad hoc style are becoming sometimes insufficient for the following reasons:

(1) Since continuous additions of ISDN features are expected, the checking of the network functions is required as early as the development stage in order to provide a system development environment interlocked with network function improvements.

(2) A continuous connectivity testing system for newly participating or added products has not been provided.

(3) In addition, the connectivity test results are not used to improve the convenience of general users because the method has not been established to handle these results.

Based on these circumstances, in order to ensure continuity and the absence of time-related restrictions of network function checks and connectivity testing, to make the connectivity testing system more reliable, as well as to encourage ISDN product development and to promote standardization and standardized systems, we have stressed the items to be performed from the service specification announcement by carriers to the provision of products to general users and the performing procedures, and compiled them in the attached "Guideline."

Guideline for Improvements of Interconnectivity and Interoperability of ISDN Terminals, Etc.

1. Scope of Guideline

The purpose of this Guideline is to improve the connectivity and operability of ISDN terminals, etc., by ensuring connectivity and the absence of time-related restrictions of network functions in network function check and connectivity testing, as well as to encourage ISDN product development and to promote standardization and standardized systems.

This Guideline does not imply compulsion, and does not have any binding effect.

2. Contents of Guideline

The following describes the items to be performed from the service specification announcement by carriers to the provision of products to general users and the performance procedures.

(1) Specification announcement

In principle, type I telecommunication carriers should announce (previously explain) the specifications of the service to be provided to the people concerned 6 months prior to its actual provision.

Also, it should provide the secretariat of the Harmonization of Advanced Telecommunication Systems Development Conference (HATS Development Conference, hereafter referred to as "Development Conference") with the information on the summary plan.

Based on the information provided, the Development Conference will arrange the overall schedule etc.

To prepare for inquiries from manufacturers, etc., the carrier should take suitable measures as required.

(2) In-house tests

To ensure that the system of each manufacturer meets certain technical standards in network-terminal connection function checking, each manufacturer should conduct in-house testing independently.

The test methods are not specified for the present, but possible methods may include two-way tests between identical products and other tests using various measuring instruments.

In the future, the Development Conference shall examine desirable testing methods as well as shared development and shared possession of protocol testing tools.

(3) Network-terminal connection function check

a) In case the specifications are modified on the network side:

- 1) Addition of major services; or
- 2) Addition of major additional services

Prior to the actual start of the service, the carrier should provide a test network for use in the connection function check using the facilities prepared for the provision of the service (test switch equipment, line equipment, etc.).

This test corresponds to the previous "preservice test." Although it is not regarded as the actual provision of service, the provision period and location of the test network may be restricted.

The users of the test network are required to take care so as not to damage the test network.

3) Addition of minor services

The same terms as item b) below shall be applied.

b) In case of connection function check with respect to commercial service network:

When the ISDN service features are further advanced in the future, it may be necessary for newly participating manufacturers to check the network connection as early as at the product development stage (using a pilot product).

In such a case, the manufacturer can connect the product to the network and check the network-terminal connection function after;

1) having passed the ordinary examination of the Terminal Survey Association; or 2) having passed the compliance testing by the carrier.

It is also possible that there may be cases in which ordinary terminal judgment cannot be applied because the product is under development. The handling of such cases will be examined separately.

(4) Terminal-terminal connectivity test

The connectivity test between products which have passed the above-mentioned steps should follow the procedure below.

1) The execution of connectivity test is determined by the management meeting of the Development Conference.

For each test the necessity of which is approved, a sectional meeting will be established to examine basic items required for the test.

2) The sectional meeting commissions the secretariat of the test execution liaison group.

3) The test execution liaison group invites participating manufacturers and examines details of the test items and procedures. In case the standard features are expanded, it also revises the corresponding test procedure.

4) The terminal-terminal connectivity test is performed on a commercial network or a network which has not been put into service.

(The virtual network used in connection between terminals is referred to as the "HATS-Net.")

To enable connection tests of newly participating or added products, a continual testing system should be arranged, including the provision of reference machines, so that tests can be executed anytime based on requests from manufacturers, etc.

5) The results of connection tests are to be fed back to the standards through the sectional meetings of the Development Conference.

To complement the domestic standards, supplements or similar documents should be created by the Telegraph and Telephone Technology Committee (TTC). In case there is a result that should be reflected in CCITT recommendations, etc., the CCITT committee of the Telecommunications Technology Deliberation Committee should notify it for an international contribution.

6) Efforts are to be made to let the results known widely.

Concretely, when the TTC confirms (by the method described separately) that a product has passed the connection test following a request from the test participant, an approval marking should be attached to the product or the fact described in the operating instructions, etc.

It is required to make users aware that the approval of connectivity as a result of the test does not guarantee connectivity with all of the service items.

The method of description in the operating instructions, etc., will be examined separately from this Guideline to avoid confusing users.

(5) Guarantee of connectivity

The procedures above will improve the connectivity between systems while making full use of the advanced features of ISDN.

It should be noted that this Guideline has been compiled for general-purpose use. Therefore, all irregular cases observed with individual products should be judged separately by the corresponding sectional meeting of the Development Conference.

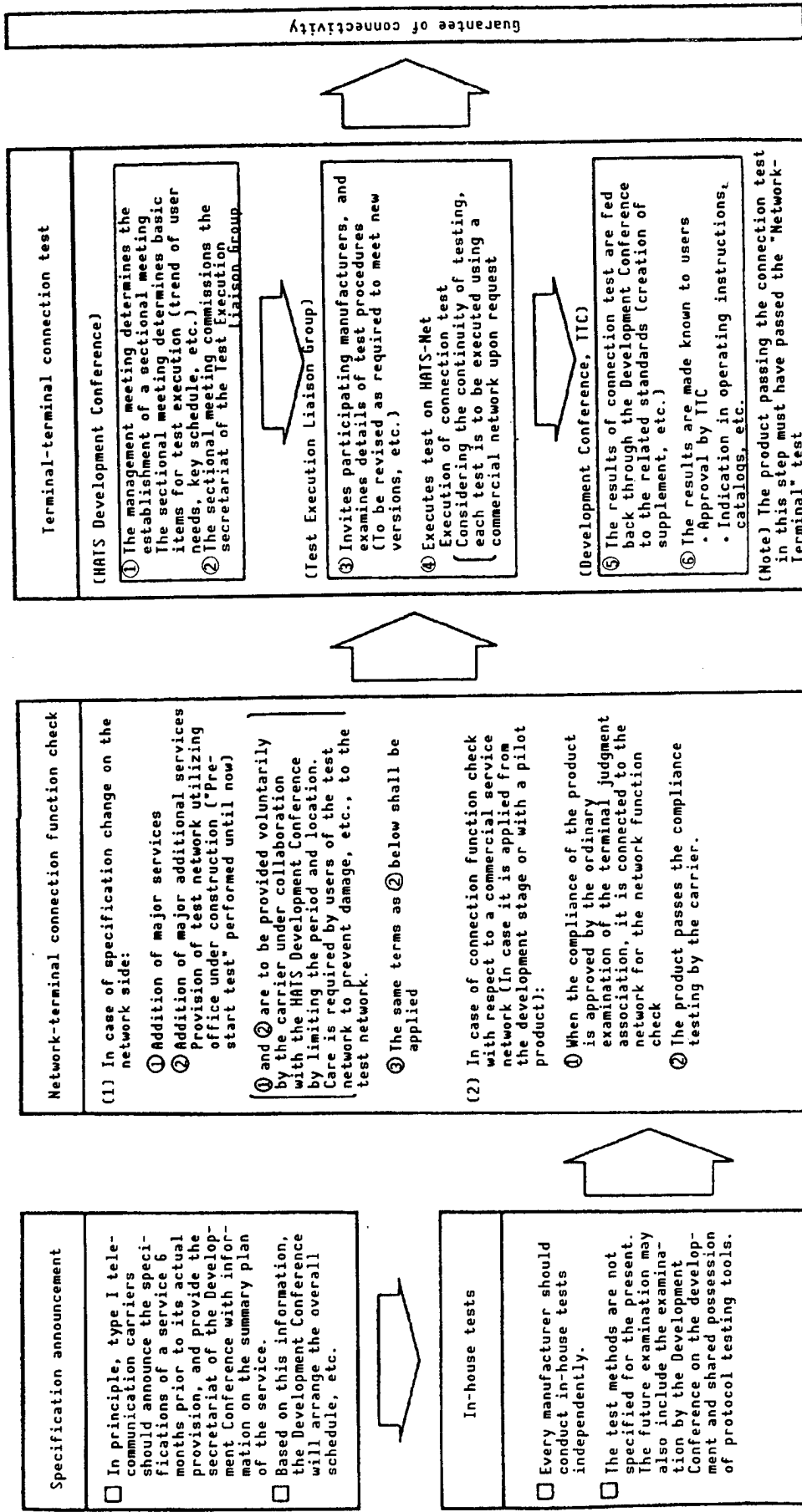

Development stage

Figure. Guideline for Improvements of Interconnectivity and Interoperability of ISDN Terminals, Etc.

Proposal of Virtual Circuit Multiple Access System

906C3837 Tokyo TSUSHIN SOGO KENKYUSHO KENKYU HAPPYOKAI in Japanese 15 Nov 89
pp 77-87

[Paper presented at a meeting of the Ministry of Posts and Telecommunications' Communications Research Laboratory on 15 November 1989. Signed by Fumihito Kubota and Kazunori Okada, both from General Communications Department]

[Text] 1. Introduction

Telecommunications networks are the foundation of society, and progress in them has become an important issue for the construction of an advanced information society in the 21st century. Contributing to the progress in telecommunications networks, many countries are now constructing integrated services digital networks (ISDNs), with which various communications services can be provided by a single integrated digital network. Also, in order to provide communications services covering a wider bandwidth that can include images, R&D into broadband ISDN (B-ISDN) is underway, aiming at its implementation in 1995 or later.

Among several technical subjects related to progress in telecommunications networks, the role of the access system which is the point of contact between the users and network requires special attention. This is because the access system requires progress in multimedia communications to incorporate various future media and connection/transmission capabilities which can deal with advanced communications services using intelligent processing technology. At the same time, it is also required to provide free mobility to terminals and individual users so that they can access the network at any time and from anywhere. Therefore, it is required to further develop the wireless communications technologies used in current mobile telephone, subscriber radio, and satellite subscriber systems and to create an access system which can integrate them with wire communications systems while fully exploiting their characteristics.

When we focus our attention on the radio transmission technology presupposing that it will constitute part of a future network access system, we find two issues to be solved. One is, naturally, the efficient utilization of

frequencies, and the other is the improvement of connection and transfer capabilities. Following ISDN, networks need integration technology which can handle various kinds of information with different characteristics and rates, including voice, data, and images, in an integrated manner. The same features should also be implemented in radio systems while assuring efficient utilization of frequencies. Based on this situation, in this paper we propose a virtual circuit multiple access (VCMA) system, a fusion of circuit switching and packet switching systems, which can handle information with different characteristics and rates with good flexibility. Also, we will examine the load factor and circuit usage rate by means of simulations and demonstrate that the VCMA system is an excellent system which can exhibit a statistical multiplexer performance (statistical smoothing of traffic variations obtainable when multiple communications share a circuit group).

2. Subjects for the VCMA System

The subjects to be discussed concerning the VCMA system in radio circuits are as follows:

(1) Flexibility with respect to types of call

Future networks must be able to handle various communications services. Table 1 shows examples of these communications services and their characteristics.

Table 1. Examples and Characteristics of Communications Services

Services	Transfer rate (bps)	Characteristics
Telephone	64K~8K	Significant requirement in time transparency Interactive communications 60 percent of communication is silent Loose error requirement
High-quality voice	64K~384K	Significant requirement in time transparency Distributed, asymmetrical traffic
Facsimile	2.4K~1.5M	Interactive communications Burst type information Asymmetrical traffic
Picture phone	64K~1.5M	Significant requirement in time transparency Bidirectional simultaneous communications Variable rate information
High-quality video	32M~150M	Distributed asymmetrical traffic Variable rate information Severe quality requirement
Data	1.2K~600M	Burst type information Severe error requirements Permissible delay fluctuations

Communications services are provided in the form of either a circuit switching service such as telephone or a packet switching circuit such as data communications. In the case of circuit switching services, the circuit is retained continuously from the beginning to the end of communications without any interruption. The transmission delay is required to be constant (time transparency). Delay fluctuations are noticed as unnatural in case of telephones. Also, if data communications are provided by a circuit switching service (in this case CBR data, or Continuous Bit Rate data, is transmitted at a constant rate), service degradation such as sync errors may occur.

On the other hand, the packet switching circuit handles information generated in bursts. The information is separated into blocks, and each block is packetized by assigning the address information, etc., which is referred to as the header. Individual packets are transferred packet by packet by means of store-and-forward switching. In this case, the requirement for delay is relatively loose but that for transmission errors is very severe. This is because many circuit errors can cause frequent retransmissions and degrade the transmission efficiency of the network.

The objective of ISDN and networks after it is to provide such communications with different characteristics and rates by integrating them through a single network. The ISDN provides information channels (B ch, H ch) and a signal channel (D ch) using an access interface named UNI (User-Network Interface), and makes both circuit switching and packet switching circuits available through a single interface. This feature is implemented by enabling common call control using the signal channel, and communications are performed by the combination of information channels and the signal channel. While ISDN is capable of switching at a determined rate, B-ISDN aims at the integrated switching of various information rates from low speed to high speed at 150 or 600 Mbps including information whose transmission rate varies during communications. As it is expected that a similar access interface will also be required by radio systems, it is desirable to use circuit connection technology which can handle various types of traffic in an integrated manner.

(2) Efficient frequency utilization

The rapid progress in radio communications, particularly in mobile communications, is astounding. It is anticipated that the number of mobile terminals will reach 10 million by the year 2000,¹ and how to deal with the large demand for frequencies in the future has become an important issue. It is therefore necessary to further enhance the efficient utilization of frequencies and to examine progress in multiple access technology which is technology enabling many users to share radio channels.

(3) Multiple access systems

Several multiple access systems have been proposed up to now. Among them, it is regarded that the TDMA (time division multiple access) system is relatively efficient in circuit switching, and the SRMA (split-channel reservation multiple access) system² is relatively efficient in packet switching. However, with both of these systems, it seems that there is much room for improvements

in flexibility with respect to various traffic rates and the efficiency of radio circuits. Table 2 shows the characteristics of these systems. (The table also shows the VCMA system which will be described in the next section.)

Table 2. Characteristics of Multiple Access Systems

System	TDMA	SRMA	VCMA
Formation of information blocks	Information is simply split according to slot length, but not formed into blocks	Information is transferred as packets to which headers are assigned for transfer control The packet length is relatively long	Information is transferred in cells with short, constant length The number of cells sent matches the amount of information generated
Call setup, circuit assignment	Constant slot positions in frames are assigned continuously	Slots are reserved and information is transferred	A virtual circuit is set Information transfer slots are assigned according to the request for each frame
In case of high traffic	Call lost	Delay Throughput degraded	Call lost Cell abandoned
Flexibility or call types	Method of accommodating packet calls requires examination	Not suitable for transfer of CBR data	Compatible with various types of calls
Circuit usage rate	Not suitable for silence compression Circuit usage rate is poor with burst-type information	Can be made relatively high Dependent on reserved access system	Statistical multiplexer effect expected thanks to transfer of significant cells only
Delay characteristics	Fixed delay due to frame assembly and disassembly	Relatively long delay, which is variable according to traffic	Fixed delay due to request and assignment, and frame and assembly and disassembly

The TDMA system has advantages in handling traffic with varying rates because it has a certain flexibility in varying slot assignment units. However, when the information is generated in bursts and the traffic rate is low, its fixed assignment of time slots will considerably degrade the circuit usage rate. On the other hand, the reserved packet system used in the SRMA system can improve circuit efficiency to a certain extent, but its relatively long transmission delay due to the store-and-forward switching that it uses and its delay fluctuations degrade the quality of circuit switching services. As a result, a countermeasure against delay is an important issue in a voice packet system in which voice and data are transferred in packets.

Therefore, to deal with future networks, it is necessary to examine, from a fresh point of view, multiple access systems which can accommodate various traffic rates with a high circuit usage efficiency.

3. Concept of VCMA System

The objective of the VCMA system is to eliminate blanks in information existing in communications and share radio circuit groups dynamically in order to achieve, simultaneously, an increase of circuit capacity by the large group effect and flexible transmission by handling traffic with different characteristics in an integrated manner.

With circuit switching, a physical transmission line is assigned as exclusive at the start of communications. In this case, the circuit is left connected and is unused when there are blanks in the information. It is known that about 60 percent of communications consists of silent sections.³ By eliminating these for more efficient utilization of circuits, DSI (digital speech interpolation) technology⁴ uses the silent sections efficiently and allows it to accommodate two or three times more telephone calls than the actual number of circuits. For the efficient utilization of radio circuits without any waste, this paper proposes the use of a VCMA system which is described in the following.

Figure 1 shows the concept of the VCMA system. Here, it is assumed that K radio terminals are connected to the base stations. This system does not assign physical circuits at the time of call origination, but sets up logical circuits. These circuits are called "virtual circuits" (VC), and physical circuits are assigned only when information is to be actually transmitted. The procedure is developed as described below.

(1) Setting up virtual circuit

First, a virtual circuit is set up when a call is originated. To distinguish between virtual circuits, a circuits number (VC No.) is assigned to each of them.

(2) Determination of blanks, formation of cells

The information string of each circuit is split into short blocks with fixed length, and it is judged whether each block is blank or not. Here, blank refers to a silent section in the case of voice communication, or a flag pattern

which fills intervals between data in the case of data communications. When a blank block is found, it is abandoned. When a significant block is found, the VC No. is assigned to it to form a cell, which will be stored in the output buffer.

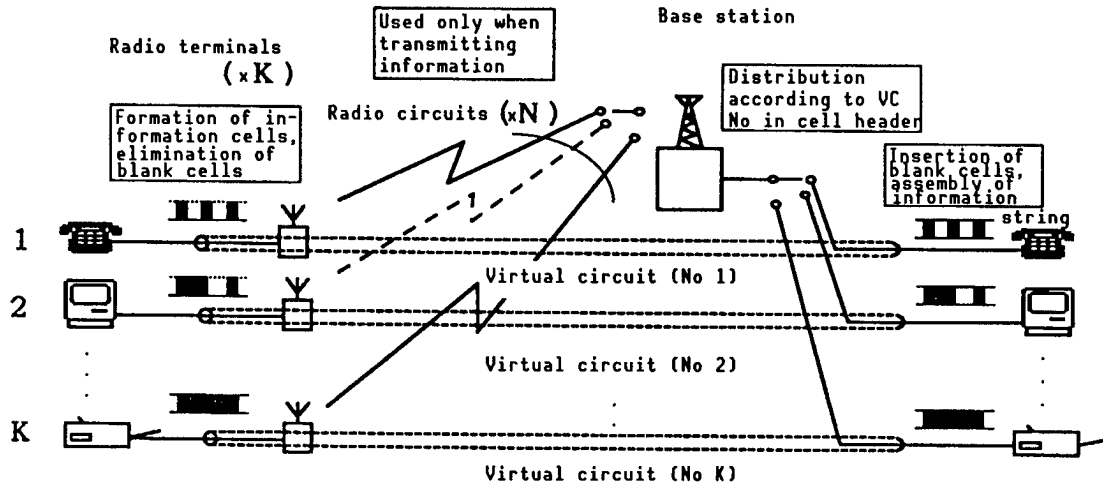

Figure 1. Concept of VCMA System

(3) Transfer by slot request and assignment

The radio communication circuit has a similar frame structure to that in the TDMA system. It assigns each frame according to the request, and transfers each cell by accommodating it in a slot. A cell is sent every few frames in the case of a low traffic rate, and several cells are sent within one frame time in the case of a high traffic rate. Since blanks are eliminated from the information, several tenths of the set circuits are idle on average, so the physical circuit capacity of the transmission lines is only a fraction of the number of virtual circuits. Conversely, this means that the number of virtual circuits that can be accommodated simultaneously can be a few times larger than the number of physical circuits. However, there could also be a case in which the number of circuits that are required simultaneously exceeds the number of physical circuits (N). In such a case, overflowing cells are abandoned. The maximum number of accommodated terminals (K) is determined based on the degree to which the degradation of circuit quality is permissible.

To control slot assignment, the proposed system provides a request and assignment control channel in addition to the cell transfer channels, and performs centralized control at the base station.

(4) Reception, assembly of information strings

The receiving side distributes cells according to their VC Nos. and assembles them into original information strings. During assembly, the blocks containing no sound or flags which have been eliminated at the transmitting side are inserted to make the time series of information equivalent to that obtained by

circuit switching, and the information series is then connected to the switching/transmission network.

With the above procedure, the VCMA system is flexible with respect to transmission rates and is compatible with both circuit switching and packet switching services.

The basic items making up the VCMA system are described below. The following examination assumes an ideal radio circuit, and does not discuss circuit degradation due to fading, which is left for future examination.

(a) Unit of virtual circuit setup

A communication (call) uses several logical channels, i.e., more than one information channel and a signal channel, and the quality standard requirements vary depending on the type of call. Therefore, the virtual circuit shall basically be set for each of the individual logical channels to enable control according to the specific quality requirements.

(b) Frame structure, cell size

The cell length is one of the fundamental parameters. If it is too short, overhead increases and efficiency will be degraded. If it is too long, there will be a problem of delay in the assembly and disassembly of cells. It must also be determined in consideration of matching with the future network, B-ISDN. Figure 2 shows the proposed cell frame configuration which adopts an information block length of 48 bytes based on the cell structure of the ATM (asynchronous transfer mode). The cell length is 78 bytes, and cells are accommodated in 12-ms frames. Under this condition, traffic generating at a rate of one cell per frame corresponds to an information transfer rate of 32 kbps. The number of slots accommodated in a frame is restricted by the upper limit of the radio transmission rate but, considering future technical advances, it is set at 80 slots so that communications of up to the ISDN primary rate interface (1.5 or 2 Mbps) can be accommodated. The radio transmission rate therefore becomes about 4.4 Mbps.

(c) Cell handling according to type of call

Based on the classification of the type of call into three categories, voice, CBR data and packet data, and also including the D ch signal with them, Table 3 shows the delay characteristic requirements and the method of cell formation and transfer for each. Basically, 48 bytes of information are formed into a cell. But it is also considered that less than 48 bytes should be permissible in the case of low-speed voice, packet data, and D ch signal transmission.

Next, as a countermeasure against overflow, it is also considered that a control function should be provided so that slots can be assigned with

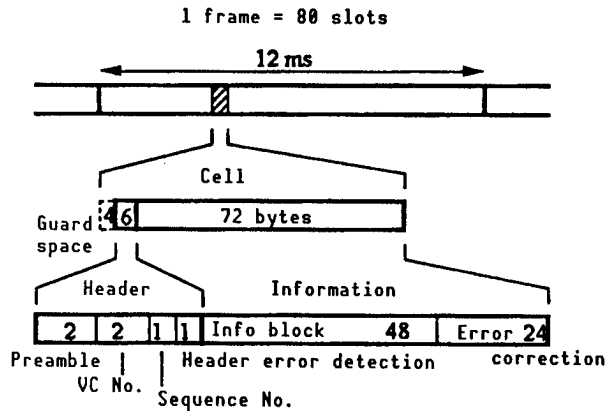

Figure 2. Proposed VCMA Frame Structure

Table 3. Handling in Formation of Cells of Each Type of Call

Call type	Delay characteristic requirement	Cell formation and transfer method
Voice	To minimize delay fluctuations in order to maintain time transparency	Cell formation of every 48 bytes 64 kbps: Transfer in 2-cell frames 32 kbps: Transfer in 1-cell frames Below 32 kbps: Transfer every few frames.*
CBR data	A certain delay is permissible, but delay fluctuations shall be minimized	Cell formation every 48 bytes Transfer by n-cell frames
Packet data	Certain delay is permissible	Cell formation every 48 bytes
D ch signal		All packets of less than 48 bytes shall form a call

*Transfer shall be performed 1 cell/frame when delay is not permissible.

the cells of the traffic with the severest transmission error requirement having priority. Specifically, priority of control shall be given in order from 1) D ch signal; 2) CBR data; 3) packet data, and 4) voice. The basic form of this system abandons cells in case of overflow, and does not consider the queuing of cells. However, with packet data with a low requirement as to time transparency, it may also be possible not to abandon overflow cells immediately but to let them queue in the send buffer. In this case, the assignment priority may have to be reconsidered.

(d) Configuration of assignment control channel

The assignment control channel which requests and assigns frames for each slot is required to have good real-time characteristics and high reliability. It is, therefore, regarded that a fixed-assignment type connection method should be selected for it. Also, since the slot request phases from the radio terminals and the assignment notification phases from the base station are repeated alternately in time, we assume the use of a time division directional (TDD) multiplexing type TDM/TDMA system. The proposed configuration is shown in Figure 3. The positions of slots are specified uniquely corresponding to the virtual circuits. If the slots are accommodated in the same frame length (12 ms) as the information transfer channels, information from 320 circuits can be accommodated in a frame.

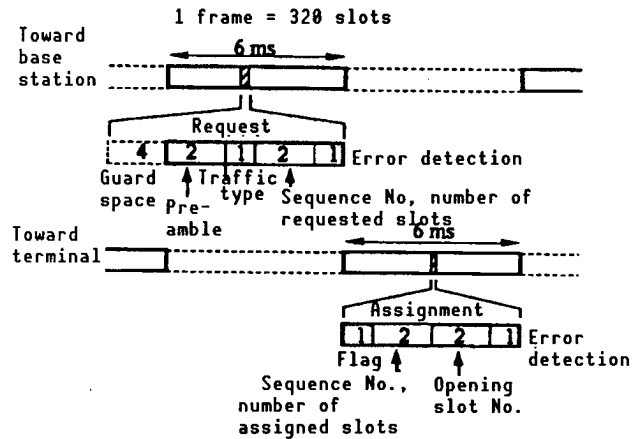

Figure 3. Proposed Frame Configuration for Assignment Control Channel

(e) Transmission delay

As this system requires request and assignment of slots before starting information transfer, it involves a certain fixed delay. Figure 4 shows the time chart of cell transfer in the circuit towards the base station. The fixed delay of the circuit towards the base station is about three frames (36 ms). The delay of the circuit towards the terminal is about one frame (12 ms), which is the same as in TDMA, because the base station at the transmitting side can perform assignment control. As is often noticed in overseas calls, long delays make conversation difficult. Delays of no more than 150 ms are permitted by telephone service standards; those of more than 150 ms, up to 400 ms, are also permitted but precautions in service are requested in this case. The maximum target delay of voice packets in voice packet systems is 250 ms. Compared to these figures, we believe that the fixed delay in the proposed system is not inappropriate. However, since radio systems as a whole still have other factors causing delay, such as voice encoding and decoding, modulation and demodulation, and error correction processing, it is still necessary to examine ways to reduce the delay caused by the proposed system as far as possible.

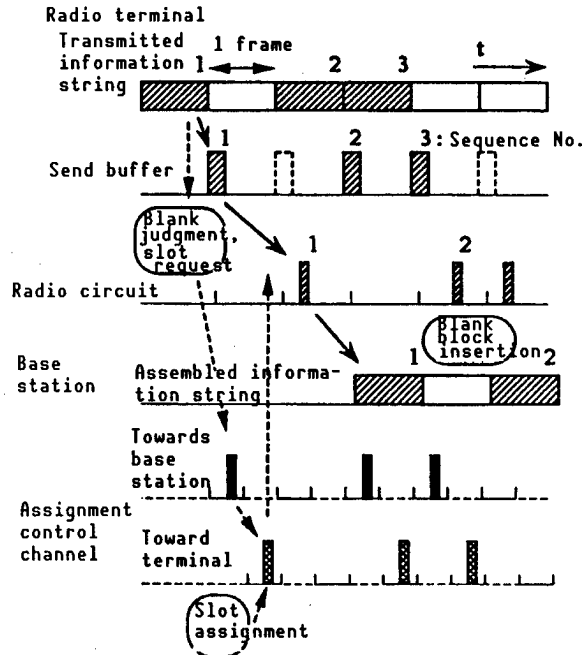

Figure 4. Time Chart of Circuit Toward Base Station

4. Evaluation by Simulation

This section deals with the results of our evaluation of the circuit utilization efficiency of the VCMA system using computer simulation. The simulation model used is shown in Figure 5. Here, a total of K virtual circuits are set for N physical circuits. As for the traffic, a mixture of two types is considered. Among the inputs, the number of inputs to which slots are assigned with priority is assumed to be K_d , and the number without priority is assumed to be K_v (where $K = K_d + K_v$).

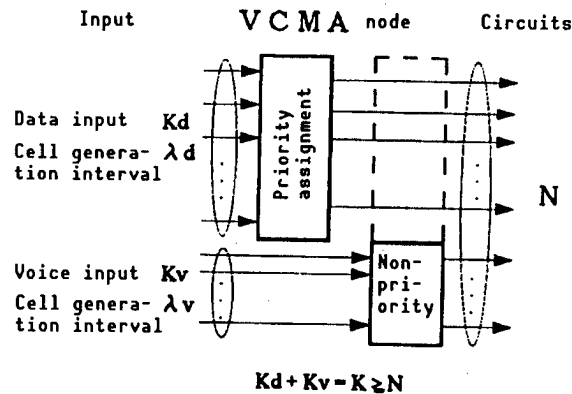

Figure 5. Simulation Model

The load conditions used in the evaluation are as shown in Table 4. Case I is the case in which all inputs are single circuit-switched traffic (voice only). Cases II with the object of the proposed system, which is the coexistence of

circuit-switching traffic and packet-switching traffic. Among the two, Case IIa is the case in which the numbers of telephone and data inputs are the same, and Case IIb is the case in which telephone calls are accepted only up to the same number as the number of circuits N, while more data calls are accepted than N. In Case III, CBR and voice data coexist in circuit switching services.

Table 4. Simulation Evaluation Conditions

Case	Assumed traffic conditions	Cell generation model	
		Voice	Data
I	All inputs are voice only	Exponential distribution average generation interval: $\lambda v = 0.4$ cell/frame	
IIa	Number of voice inputs = Number of packet data inputs (Data is transferred with priority)		Exponential distribution $\lambda d = 0.08$ cell/frame
IIb	Number of voice inputs = Number of circuits (Data is transferred with priority)		
III	All calls are circuit-switching calls, and the ratio between CBR data inputs and voice inputs is varied (Data is transferred with priority)		Exponential distribution $\lambda d = 0.5$ cell/frame

As the scale of evaluation, the ratio of the number of virtual circuits (K) with respect to the number of physical circuits (N), that is K/N , is defined as the "load factor." Then, the maximum load factors which can provide a cell abandonment rate (α) of 10^{-3} and 10^{-2} for voice cells with the lowest priority were obtained, (Footnote: Abandonment of cells constitutes burst type transmission errors. The abandonment rate of voice cells varies depending on the voice encoding systems, and the standard is estimated at 10^{-3} or 20^{-2} . In the proposed model, the voice cell abandonment rate of 10^{-3} corresponds to the bit error rate of 0.4×10^{-3} .) and circuit usage rates with those load factors were obtained. Here, the "cell abandonment rate" refers to the ratio of cells abandoned due to overflow compared to all cells to be transmitted (containing sound). The "circuit usage rate" refers to the average usage rate of slots making up the frames of cell transfer channels. This figure was compared with the maximum value with the TDMA system which uses the same frame configuration.

It was assumed that both the voice and data cells are generated with a Poisson process, that is, the average cell generation intervals had an exponential distribution of λ_v and λ_d , respectively. The Marcov Modulated Poisson Process (MMPP)⁵ and Interrupted Poisson Process (IPP) are often used as voice cell generation models, but it is reported that these models approach the Poisson process itself as the amount of multiplexing is increased, and that there is very little difference with 20 circuits or more.⁶ For the packet data, we assumed a traffic which can output 1.2 pages of text consisting of 8 kilobits per page every minute. It was also assumed that the CBR data is continuously used in one circuit direction but the other direction is idle. Strictly speaking, the model shown in Figure 5 represents a Bernoulli distribution with K inputs. A small error may occur if it is approximated by the Poisson process with an infinite number of inputs. However, as the cell abandonment rate obtained is always relatively large, the following results can be regarded as safer evaluations. The SLAM-II language was used for the simulation.

(1) Case I: Voice traffic only (Figures 6 to 9)

Figure 6 shows the relationship between the load factor and circuit usage rate. Note that, with TDMA, the maximum load factor is 1 and the circuit usage rate at this time is 0.4. Figure 7 shows the variation of the voice cell abandonment rate against the load factor. Based on the results obtained from Figure 7, Figure 8 was obtained by plotting the maximum load factors which provide voice cell abandonment rates of 10^{-3} and 10^{-2} with respect to the number of circuits. The maximum load factor increases almost proportionally to the logarithm of the number of circuits. When the number of circuits is 80, twice the number of virtual circuits can be accommodated, where the so-called DSI effect is clearly demonstrated. Figure 9 shows the circuit usage rate as a relative value with respect to the TDMA. Note that the calculation of relative circuit usage rate does not include the assignment control channel.

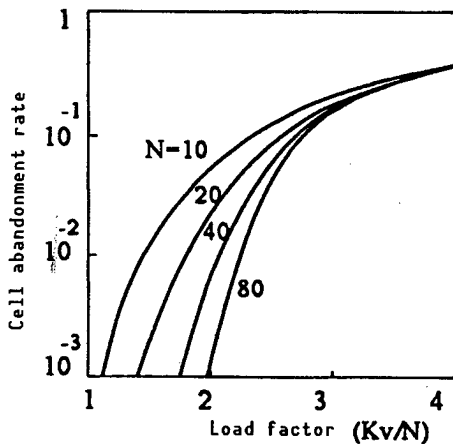

Figure 6. Circuit Usage Rate (Case I)

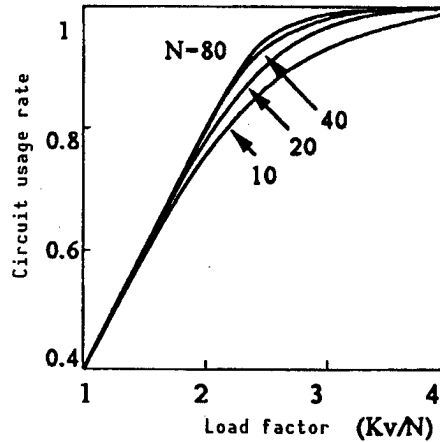

Figure 7. Cell Abandonment Rate (Case I)

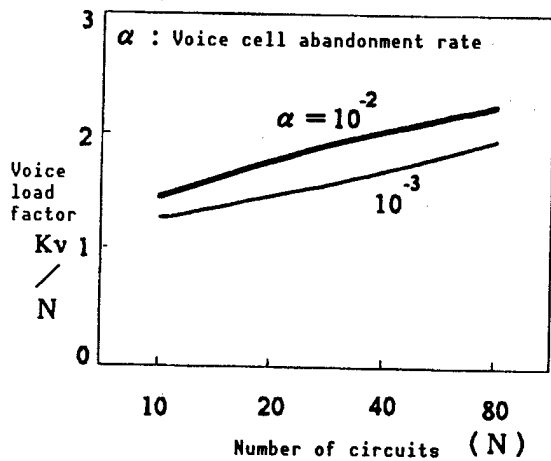

Figure 8. Relationship Between Load Factor and Number of Circuits (Case I)

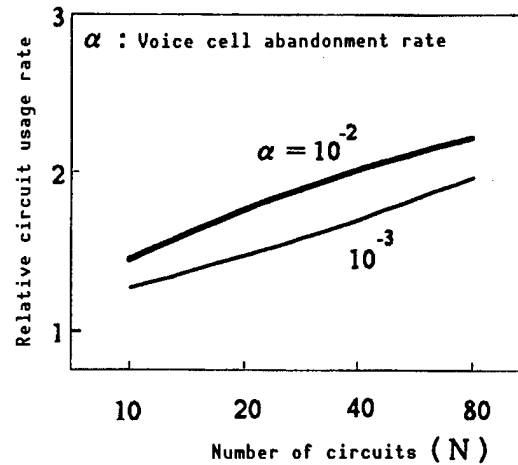

Figure 9. Relative Circuit Usage Rate (TDMA = 1) (Case I)

(2) Case II: Voice + packet data (Figures 10 and 11)

Figure 10 shows the maximum data load factor when the number of voice inputs (K_v) is constant ($K_v = N$) or equal to the number of data inputs (K_d). Figure 11 shows the relative circuit usage rate under this condition. The statistical multiplexer performance when different types of traffic are accommodated can be seen here. Particularly, when the number of circuits (N) increases, both the maximum load factor and circuit usage rate are dramatically improved. In case the number of voice inputs is limited to equal the number of circuits ($K_v = N = \text{const.}$), the maximum data load factor when the number of lines (N) is 80 can be more than 4. This means that, while handling the same number of voice calls as the number of circuits, it is also possible to handle four or five times more packet data calls than circuits.

(3) Case III: Voice + CBR data (Figures 12 and 13)

In case the voice and CBR data coexist in circuit switching services, increasing the ratio of CBR data to which priority control is applied will reduce the maximum load factor more than in case of voice inputs only. Even in this case, however, it does not drop below the case of TDMA. Figure 12 shows the maximum load factors obtained using the ratio of CBR data as the parameter. The curve of $K_d/K = 0$ is the case in which all the inputs are voice. When the ratio of CBR data is increased above this, the maximum load factor tends to decrease uniformly. The decrease of the maximum load factor following the increase of the ratio of CBR data is shown in Figure 13. Within the range of our simulation, the maximum load factor tended to drop linearly as the CBR data ratio increases. Figure 13 shows only the case in which $N = 80$ and $\alpha = 10^{-3}$, but the general tendency was almost the same under other conditions.

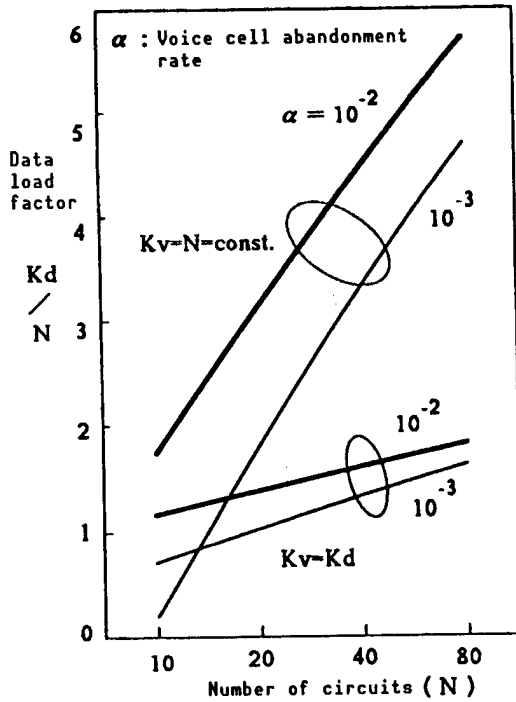

Figure 10. Data Load Factor (Case II)

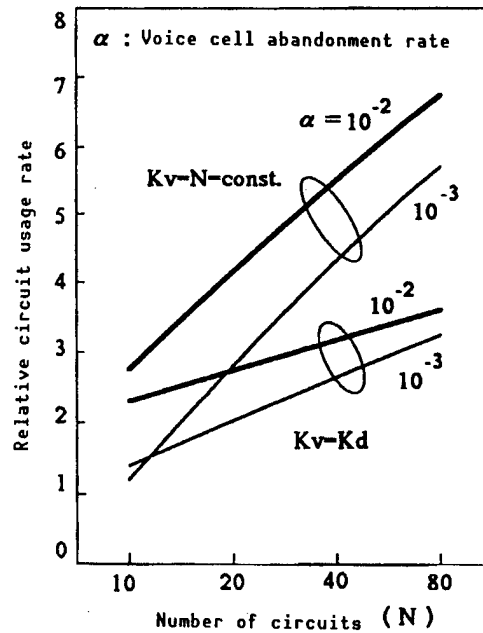

Figure 11. Relative Circuit Usage Rate (Case II)

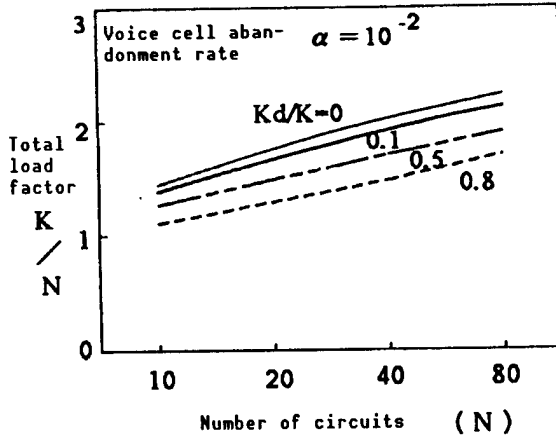

Figure 12. Maximum Total Load Factor When Voice and CBR Data Coexist (Case III)

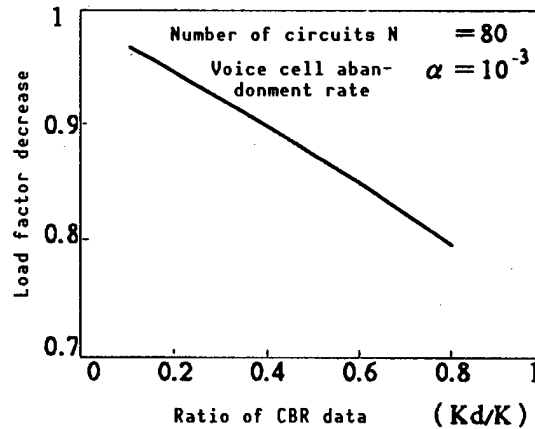

Figure 13. Decrease of Maximum Load Factor Due to Coexistence of CBR Data (Case III)

From the above evaluation by simulation, it was demonstrated that the VCMA system can double the radio circuit group capacity and circuit usage rate compared to the TDMA system, and that it is particularly effective when accommodating various types of traffic. In the future, we will further develop the evaluation of performance by clarifying multimedia traffic models, and reflect the results in the examination of access systems.

5. Conclusion

In the above we pointed out that the subjects to be studied in multiple access systems for use in future radio system consists of providing the flexibility required to handle various types of traffic in an integrated manner and to pursue an efficient utilization of frequencies, and described the concept of the VCMA system as a means of their implementation. We presently aim at implementing a VCMA system which can handle transmission rates of 1.5 Mbps which is standardized as the ISDN primary rate interface rate or even up to 2 Mbps, while also continuing the examination of the system to elucidate its effectiveness.

To ensure high-quality communications at any time and from any place, progress in the network access system which is the point of contact for users is a very important issue. Access systems are expected to be constructed based on the organic association of radio and wire communications systems, and it is anticipated that they will be provided in various forms. In this paper, we focused on transmission performance, but we believe that it is also necessary to consider the issue from various standpoints, including that of the connection performance, i.e., the call control systems of the future, as well as other aspects of communications including the free mobility and provision of personal communications.

Appreciation

We would like to express our deep gratitude to Manager Yokoyama of the General Communications Department, Director Mizuno of the Integrated Communications Network Laboratory, its ex-director Hashimoto, as well as to persons concerned in the CRL who helped us in preparing this paper. Also, we thank M. Kobayashi, technical officer of Okinawa Observatory, and M. Kobayashi, trainee at Toyo University, for their assistance in the computer simulation.

References

1. Kubota, F. and Hashimoto, "Technology Trends and Topics of Telecommunications Network," TSUSHIN SOGO KENKYUSHO KIHO, Vol 35 No 176, September 1989.
2. Tobagi, F.A. and Kleinrock, L., "Packet Switching in Radio Channels: Part III—Polling and (Dynamic) Split-Channel Reservation Multiple Access," IEEE TRANS. COMM., Vol COM-24, No 8, August 1976.
3. Dias, L.A., "Packetized Voice on a Single DATAKIT Packet Switch Node," ICC'84, 1984.
4. Lyghounis, E., Poretti, L. and Moriti, G., "Speech Interpolation in Digital Transmission Systems," IEEE TRANS. COMM., Vol. COM-22, No 9, September 1974.

5. Heffes, H. and Lucantoni, D., "A Marcov Modulated Characterization of Packetized Statistical Multiplexer Performance," IEEE J. SELECTED AREAS IN COMM., Vol SAC-4 No 6, September 1986.
6. Noguchi, Okada and Onishi, "The Flow Control Method in Multi-Media Communications," SHINGAKU GIHO, IN86-65, 1986.

- END -

22161

45

NTIS
ATTN: PROCESS 103
5285 PORT ROYAL RD
SPRINGFIELD, VA

22161

This is a U.S. Government policy, view, or attitude of cite FBIS or JPRS provided the secondary source.

Foreign Broadcast Information Service (FBIS) and Joint Publications Research Service (JPRS) publications contain political, military, economic, environmental, and sociological news, commentary, and other information, as well as scientific and technical data and reports. All information has been obtained from foreign radio and television broadcasts, news agency transmissions, newspapers, books, and periodicals. Items generally are processed from the first or best available sources. It should not be inferred that they have been disseminated only in the medium, in the language, or to the area indicated. Items from foreign language sources are translated; those from English-language sources are transcribed. Except for excluding certain diacritics, FBIS renders personal names and place-names in accordance with the romanization systems approved for U.S. Government publications by the U.S. Board of Geographic Names.

Headlines, editorial reports, and material enclosed in brackets [] are supplied by FBIS/JPRS. Processing indicators such as [Text] or [Excerpts] in the first line of each item indicate how the information was processed from the original. Unfamiliar names rendered phonetically are enclosed in parentheses. Words or names preceded by a question mark and enclosed in parentheses were not clear from the original source but have been supplied as appropriate to the context. Other unattributed parenthetical notes within the body of an item originate with the source. Times within items are as given by the source. Passages in boldface or italics are as published.

SUBSCRIPTION/PROCUREMENT INFORMATION

The FBIS DAILY REPORT contains current news and information and is published Monday through Friday in eight volumes: China, East Europe, Soviet Union, East Asia, Near East & South Asia, Sub-Saharan Africa, Latin America, and West Europe. Supplements to the DAILY REPORTs may also be available periodically and will be distributed to regular DAILY REPORT subscribers. JPRS publications, which include approximately 50 regional, worldwide, and topical reports, generally contain less time-sensitive information and are published periodically.

Current DAILY REPORTs and JPRS publications are listed in *Government Reports Announcements* issued semimonthly by the National Technical Information Service (NTIS), 5285 Port Royal Road, Springfield, Virginia 22161 and the *Monthly Catalog of U.S. Government Publications* issued by the Superintendent of Documents, U.S. Government Printing Office, Washington, D.C. 20402.

The public may subscribe to either hardcover or microfiche versions of the DAILY REPORTs and JPRS publications through NTIS at the above address or by calling (703) 487-4630. Subscription rates will be

provided by NTIS upon request. Subscriptions are available outside the United States from NTIS or appointed foreign dealers. New subscribers should expect a 30-day delay in receipt of the first issue.

U.S. Government offices may obtain subscriptions to the DAILY REPORTs or JPRS publications (hardcover or microfiche) at no charge through their sponsoring organizations. For additional information or assistance, call FBIS, (202) 338-6735, or write to P.O. Box 2604, Washington, D.C. 20013. Department of Defense consumers are required to submit requests through appropriate command validation channels to DIA, RTS-2C, Washington, D.C. 20301. (Telephone: (202) 373-3771, Autovon: 243-3771.)

Back issues or single copies of the DAILY REPORTs and JPRS publications are not available. Both the DAILY REPORTs and the JPRS publications are on file for public reference at the Library of Congress and at many Federal Depository Libraries. Reference copies may also be seen at many public and university libraries throughout the United States.