

JPRS Report

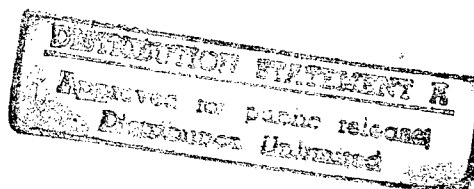

Science & Technology

CHINA: Energy 5MW Thermal Heating Reactor

DIC QUALITY INSPECTED 2

REPRODUCED BY
U.S. DEPARTMENT OF COMMERCE
NATIONAL TECHNICAL INFORMATION SERVICE
SPRINGFIELD, VA. 22161

22161
14

NTIS
ATTN: PROCESS 103
5285 PORT ROYAL RD
SPRINGFIELD, VA

22161

19980203 082

Science & Technology

China: Energy

5MW Thermal Heating Reactor

JPRS-CEN-91-002

CONTENTS

25 January 1991

Status, Prospect of District Heating Reactor in China [Wang Dazhong, Ma Changwen, et al.; HE DONGLI GONGCHENG, 10 Oct 90]	1
Safety Features, Design Criteria of 5 MW THR [Zheng Wenxiang, Dong Duo, et al.; HE DONGLI GONGCHENG, 10 Oct 90]	2
Physical Start-Up of 5 MW THR [Luo Jingyu, Xu Kuan, et al.; HE DONGLI GONGCHENG, 10 Oct 90]	4
Design, Experimental Research of Hydraulic Control Rod Drive System for 5 MW THR [Wu Yuanqiang, Hu Yuedong, et al.; HE DONGLI GONGCHENG, 10 Oct 90]	8
Safety Analysis, Evaluation of Hydraulic Control Rod Drive System in 5MW THR [Hu Yuedong, Wu Yuanqiang, et al.; HE DONGLI GONGCHENG, 10 Oct 90]	12
Fuel Assembly of the 5MW THR [Xu Yong, Zhang Zhensheng; HE DONGLI GONGCHENG, 10 Oct 90]	15
Pressure Vessel and Containment for the 5MW THR [He Shuyan, Xiong Dunshi, et al.; HE DONGLI GONGCHENG, 10 Oct 90]	19
State Planning Commission Gives Go-Ahead on 200MW Heat-Supply Reactor [Wang Yadong; JINGJI RIBAO, 19 Sep 90]	22
5MW Heat-Supply Reactor Is Big Success for Qinghua University [He Huangbiao, Ma Xuquan; RENMIN RIBAO, 19 Sep 90]	22

Status, Prospect of District Heating Reactor in China

916B0017A Chengdu HE DONGLI GONGCHENG
[NUCLEAR POWER ENGINEERING] in Chinese
Vol 11, No 5, 10 Oct 90 pp 2-7

[Excerpt from article by Wang Dazhong [3769 1129 0022], Ma Changwen [7456 2490 2429], Dong Duo [5516 6995], and Lin Jiagui [2651 1367 2710] of the Qinghua University Nuclear Energy Institute, Beijing: "The Current Situation and Prospects for Research and Development on the Nuclear Heating Reactor"; initial draft received 23 Apr 90, revised draft received 6 Jun 90]

[Excerpt] [passage omitted]

III. Current Situation in Development of Nuclear Heating in China

Research has been done in many areas since Qinghua University proposed doing research and development on nuclear heating in 1981. In 1983, Qinghua University's Nuclear Energy Institute did more than two heating-season nuclear heating experiments with a swimming pool shielded reactor. The experiments showed that nuclear heating could rather easily satisfy load variation and environmental dosage safety requirements. All feasible heating reactor programs also were compared. Feasibility research was also carried out based on the experimental results and a casing-type integrated natural circulation program was adopted in March 1984. The main characteristics of this program were: 1) Low temperature, low pressure, and low power density; 2) Full-power natural circulation; 3) Integrated configuration, dual pressure-bearing vessels; 4) Hydraulic drive device to drive the control rods, which eliminates the possibility of rod elasticity accidents caused by hole interface rupturing; 5) Use of isolation loops to completely isolate the radioactive primary loop from the heat network loop. As a result, this reactor has inherent safety characteristics which enable: 1) Automatic reactor shutdown during accidents; 2) The reactor core is always flooded with water; 3) Residual heat is dissipated through natural circulation into the atmosphere during reactor shutdowns without requiring any additional external drive; 4) It can reliably isolate radioactive materials and protect environmental safety. Thus, it is a reactor with excellent inherent safety that is suitable for use in centralized urban heating.

Research work in all areas got fully underway in 1984. It included these key technical aspects: no-power physical experiments, heat exchanger flow resistance and flow rate distribution experiments, core thermal hydraulics experiments, ultrasonic position indicator experiments, boron injection experiments, radiation leakage experiments, pierced casing sealing experiments, loading and unloading structure experiments, various types of computer and display software, and so on. These key technical experiments were basically completed between 1984 and 1986 and research on low-temperature heating reactors was included among state projects to attack key

S&T problems during the Seventh 5-Year Plan in 1986, and it received substantial support from the state. The key aspects mainly included construction of a 5 MW experimental reactor and completion of key technical research on a large 200 MW commercial reactor. This provided the technical and design foundation for construction of a commercial-scale demonstration project.

Construction of the experimental 5 MW low-temperature nuclear heating reactor (also called the 5 MW Test Heating Reactor or 5 MW THR) began in March 1986. Its primary parameters and the principles of its structure and systems are similar to those in the commercial reactor to facilitate the obtaining of the required experience and data to serve the commercial reactor. Moreover, the 5 MW THR will also serve a base area for R&D concerning low-temperature reactors and will make a contribution to further perfection and development of low-temperature heating technologies. In November 1989, criticality was achieved for the first time in the 5 MW THR and it attained full power on 16 Dec 89. It supplied heat to the structures surrounding the reactor until 22 Mar 90 and successfully operated for its first heating season.

At the same time, a joint preliminary feasibility analysis report by China and Federal Germany for the commercial heating demonstration station was completed in July 1988. Conceptual designs were completed for a 450 MW, 2 X 200 MW, and 200 MW commercial demonstration station and research work related to the commercial demonstration station has now gotten underway. Construction of the commercial heating demonstration station is expected to begin in 1992 and it will be completed in 1995, after which it will be fully extended.

IV. Development Prospects

As described above, low-temperature heating reactors have significant advantages in the areas of reducing the energy resource and the communications and transportation shortages, and in reducing environmental pollution. Combined with their low cost, they have a broad market in the north China region. Feasibility analysis or planning is now being carried out for constructing low-temperature nuclear heating stations in over 10 cities and enterprises including Harbin, the Changchun No 1 Truck Plant, Jilin Chemical Industry Company, Shenyang City, and other places. Some southern provinces also want to use nuclear heating reactors as an industrial heat source. It can be expected that on the basis of completing construction of the first demonstration reactor and gaining experience, there will be substantial development of low-temperature heating reactors.

To improve the economy of nuclear heating reactors and expand their range of applications, we are now undertaking research work in low-temperature cooling, irradiation applications, low-temperature technical heating (boiling sugar, boiling salt, supplying steam, etc.), low-temperature power generation, and other areas.

As this research work progresses and all countries in the world develop low-temperature nuclear heat supplies, low-temperature nuclear heating reactors will reveal their even brighter prospects.

Safety Features, Design Criteria of 5 MW THR

916B0017B Chengdu HE DONGLI GONGCHENG
[NUCLEAR POWER ENGINEERING] in Chinese
Vol 11, No 5, 10 Oct 90 pp 15-18

[Article by Zheng Wenxiang [6774 2429 4382], Dong Duo [5516 6995], Ma Changwen [7456 2490 2429], Lin Jiagui [2651 1367 2710], and Wang Jiaying [3769 1367 5391] of the Qinghua University Nuclear Energy Technology Institute, Beijing; manuscript received 23 Apr 90]

[Text]

Abstract: This article introduces the primary safety features and component design criteria of the 5MW THR and suggests some problems that exist in the safety design of the nuclear heating reactor.

Key words: 5MW experimental low-temperature nuclear heating reactor, inherent safety, design criteria.

I. Introduction

Taking into consideration the economy of heat supplies, nuclear heating reactors are usually built near regions with dense populations, meaning that they are near heat supply users, so the safety requirements for low-temperature nuclear heating reactors should be higher than those for nuclear power plants. Of course, to achieve the safety goals and economy of nuclear heating reactors, we cannot follow the original design ideas for nuclear power plants, which involve ever-higher quotas for safety and excessive reliance on cumbersome engineering safety facilities. Instead, we should select reactor types that have good inherent safety characteristics and simple systems that are easy to operate.

II. Inherent Safety Requirements for Low-Temperature Nuclear Heating Reactors

The safety goals for low-temperature nuclear heating reactors basically should rely on excellent inherent safety characteristics and not be achieved by additional increases in design grades and increased amounts of various types of safety facilities. At present, several countries are following this sort of idea in studying various types of low-temperature nuclear heating reactors. Concrete manifestations of this type of inherent safety covers the following: 1) Larger negative reactivity parameters; 2) Decay heat within the reactor relies on natural convection and (or) heat exchange for discharge; 3) Low operating pressures; 4) Low probability of loss of coolant accidents occurring; 5) Ability to contain high-temperature radioactivity; 6) When accidents involving the exceeding of design baselines occur, there is sufficient time to adopt temporary emergency measures to reduce the effects of the accident.

III. Safety Features of the 5MW THR

The 5MW THR was designed on the basis of the principles outlined above. This reactor is an integral, natural circulation, and natural pressure stabilization light-water reactor. The system operating pressure is 1.47 MPa and the coolant relies on density differentials formed in the cold section and hot section to form natural circulation within the pressure vessel. The heat within the reactor is conducted into an intermediate loop via a main heat exchanger and then conducted into the heat network via the intermediate heat exchanger. This reactor design guarantees that there is always a rather large negative temperature coefficient during the entire reactor operation period. Moreover, various types of design measures are adopted to prevent a loss of water in the reactor core and to ensure that under any design baseline accident conditions the core is not uncovered and that radioactive material is prevented from leaking into the heat network. The main design characteristics for this reactor and analysis of their safety features can be outlined as follows:

A. Rather large negative temperature coefficient

The nuclear design provides the reactor core with a rather large moderator negative temperature coefficient under all operating states from cold state zero-power and up. The rather substantial reactivity feedback gives this reactor excellent self-stabilization and regulation properties and can greatly reduce the effects of reactivity loss of control addition, ATWS, and other types of accidents. Analysis has shown, for example, that when a full-plant power outage ATWS accident occurs, the rather large temperature feedback effects cause the reactor power to drop to a very low level and keep the reactor core submerged in the water for long periods. In another example, heat network load shedding and load increase experiments showed that without adopting any measures at all reactor parameters could automatically track and stabilize under any conditions.

B. Integrated pressure self-stabilization design

The main heat exchanger is installed inside the reactor pressure vessel and the system pressure is maintained by relying on the steam space in the upper part of the vessel. Besides a few small-diameter technical inlet and outlet pipes on the pressure vessel, there are no coarse pipelines or large complex components extending outside. This greatly reduces the probability of coolant pressure marginal leaks and can greatly reduce the aftereffects of leakage accidents. This design feature and other features to be described below can ensure that the reactor is not uncovered under design baseline accident conditions, so there is no need to install an emergency core cooling system on this reactor.

C. Natural circulation cooling

Full power natural circulation cooling is achieved in the primary loop system. There is no need for an external drive, which eliminates main circulation pumps,

rotating components which are prone to damage and increases the reliability of reactor cooling. At the same time, the residual heat discharge system also employs a natural circulation arrangement, so suitable cooling of the reactor core can be maintained for long periods when external power sources are lost.

D. Dual-layer casing structure

The containment vessel for the 5MW THR is placed close to the pressure vessel and it can withstand rather high pressures. This means that when a coolant pressure marginal loss accident occurs in the containment vessel, it also can ensure that the core is submerged in cooling water.

E. Installation of isolation loops

The 5MW THR employs three redundant loops, one loop in the reactor and intermediate loops between them and the heat network, to separate the water in the first loop from the heat network. In addition, the operating pressure of the intermediate loops is 1.7 MPa, which is higher than the 1.47 MPa pressure in the first loop system, and there are various types of auxiliary monitoring protection and isolation measures that can effectively prevent leakage of radioactive water into the heat network.

F. Low operating parameters, large heat inertia

The design characteristics of low operating parameters and large heat inertia can increase system equipment reliability and smooth out variations in process parameters under transient working conditions or accident conditions.

G. Reliable reactor shutdown system

The control rod drive mechanism for the 5MW THR uses a hydraulic drive system, the control rods do not extend outside of the pressure vessel, and the drive medium is the reactor coolant. With these design features and loss of safety design principles (power outages, flow loss, pipe ruptures, and all other accidents cause the rods to drop), it would not be possible for reactor disturbance accidents due to control rod elasticity accidents or other causes to occur. This reactor is also configured with a boron injection system as well as two arrangements with reserve pump boron injection and nitrogen gas boron injection, which further ensure confidence in the ability to achieve safe reactor shutdown.

H. Simple system, easy operation

For any type of design baseline accident, the protection logic system has only two actions for automatic contact, which are reactor shutdown and opening the residual heat discharge system valves. This greatly reduces the possibility of operation errors.

Because the 5MW THR has excellent inherent safety properties, it can ensure that a design baseline accident cannot cause a loss of cooling in the core and create the

release of large amounts of radioactive materials, and that the core will not be uncovered over a relatively long period of time (several hours to several 10 hours) even in a baseline-exceeding accident (such as an ATWS accident in combination with a loss of boron injection or an ATWS accident in combination with a failure of the safety valves to reseal, for example). This gives operating personnel sufficient time to adopt temporary emergency measures to reduce the aftereffects of an accident like replenishing the water in the reactor, using other routes to inject boron into the core, and so on. In summary, safe operation in this reactor is assured and guaranteed.

IV. Design Criteria and Component Grades

A. Design criteria

Heating reactors have different safety requirements than nuclear power plants. The choices of design standards for structural materials, components, equipment, systems, and so on are related to their safety properties and they affect their economy and development prospects. There are no design regulations or criteria that can be borrowed in China or from foreign countries at present, so during the design and construction of the 5MW THR we adopted these principles: 1) Design characteristics are based on heating reactors; 2) Design criteria take into consideration nuclear power plant laws and regulations; 3) Consideration is given to the differences between experimental research reactors and commercial reactors; 4) We began with the actual situation in China's current industry standards and regulations to determine appropriate technical requirements.

The 5MW THR has design characteristics like the adoption of integrated natural circulation and so on which give it excellent inherent safety properties, so we could not completely copy the 10CFR50 and APP-A general design criteria (GDC) used in nuclear power plants, the "Nuclear Power Plant Design Safety Regulations" (abbreviated hereafter as "Safety Regulations" issued by China's Nuclear Safety Bureau, and so on. The primary parts of nuclear power plant design criteria that should receive special consideration are:

1. Because the reactor core for these reactor cannot be uncovered in a design baseline accident, there is no need in principle to install a core emergency cooling system, so GDC 35-37 and "Safety Regulations" 6.6 and 6.7 are not suitable for this reactor.

2. Because the containment vessel of this reactor is placed very close to the pressure vessel and is a pressure-bearing casing, consideration of its safety performance makes it unsuitable or unnecessary to install a containment vessel heat discharge system and air valves, nor are there spaces and coatings on the containment vessel, and so on, so GDC 38-40 and "Safety Regulations" 8.7 to 8.9, 8.11, and so on are not suitable for use in this reactor.

3. Because this reactor employs an integrated configuration program and is a small experimental reactor, the

principles for in-service inspection and maintenance of the primary heat exchanger do not conform completely to the requirements in GDC 32 and the "Safety Regulations".

4. Because this reactor can ensure that the core is not uncovered in a design baseline accident, safety principles do not require the installation of a safety-grade coolant replenishment system that has a reliable power supply source. Thus, GDC 33 and "Safety Regulations" 6.3 are not entirely suitable for the reserve water replenishment system installed on this reactor.

5. Based on the characteristics of the heating reactor, the ventilation system on this reactor is not an important safety system and there can be no residential-type requirements for the control room, so the relevant criteria and ventilation systems are not appropriate.

B. Component grades

Component grades are an important foundation for the design. All of the structural materials, systems, equipment, and components for the 5 MW THR can be divided into the two main categories of materials and items that are important for safety and materials and items that are not important for safety. The latter belongs to the non-safety grade and the design requirements adopt conventional quality standards. The former require determination of grades according to the safety functions they perform and then the selection of corresponding quality standards to satisfy safety requirements. The component grades for this reactor are simpler than in nuclear power plants. The concrete situation is as follows:

The fluid containment margin (or system) is divided into safety grades 1 and 2 (and can also be divided into grades 1, 2, and 3) and non-safety grade and their quality standards are determined on this basis. Safety grade 1 is all the components that form the reactor coolant pressure margin, meaning the pressure vessel, primary side of the main heat exchanger and technical connecting pipes on the pressure vessel (that extend into and include the isolation valves inside the containment vessel) ≥ 25 mm in diameter. Of course, because the pressure on the secondary side of the main heat exchanger is higher than on the primary side, the primary heat exchanger also can be grade-2 components. Safety grade 2 includes the control rod hydraulic drive system, boron injection system, residual heat discharge system, containment vessel and isolation system, and so on.

All other categories of devices or components such as the control instruments system, electrical system, ventilation system, supporting structure, crane equipment, and so on are both safety grade and non-safety grade.

V. Conclusion

The 5MW THR employs new design concepts. The situation with this reactor since it was placed into operation confirms that it has excellent inherent safety properties. Now, similar design concepts are being used for the

preliminary design of the 200 MW heating demonstration reactor, but still there are problems in actual work concerning the suitability of nuclear heating safety properties and design criteria, so we should try to formulate safety laws and regulations and design standards for nuclear heating reactors to enable faster progress in commercialization of low-temperature nuclear heating reactors.

Physical Start-Up of 5 MW THR

916B0017C Chengdu HE DONGLI GONGCHENG
[NUCLEAR POWER ENGINEERING] in Chinese
Vol 11, No 5, 10 Oct 90 pp 32-35, 52

[Article by Luo Jingyu [5012 4842 1342], Xu Kuan [1776 1401], Xu Xiaolin [1776 1420 3829], Shan Wenzhi [0830 2429 1807], Jing Xingqing [4842 3322 3237], and Bian Hui [6708 2547] of the Qinghua University Nuclear Energy Technology Institute, Beijing; manuscript received 23 Apr 90]

[Text]

Abstract: The loading, first criticality, and control rod levelling experiment characteristics and results are described for the 5MW THR. The extrapolation methods and actual steps taken to ensure safety are introduced. To reduce spatial effects, special measurement measures were employed during the loading and extrapolated criticality process. Practice has proven that these methods are effective.

Key words: 5MW experimental low-temperature nuclear heating reactor, first criticality, reactivity, control rod, neutron detector, extrapolation.

I. The Importance of Reactor Physical Start-Up Experiments

Physical start-up experiments are an indispensable and important step after completing a nuclear reactor. First, they provide essential data and information for subsequent start-up and operation, especially for nuclear safety. Second, they allow obtaining of comprehensive characteristics for the reactor structure, control (including protection systems), and core physical properties and they are start-up training under specially monitored conditions. Third, they provide the ultimate data on the correctness of the nuclear reactor physical design and project construction and provide directions for subsequent reactor research and improvement. Fourth, success in the first physical start-up experiments indicate success in reactor construction and operability.

In building the initial prototype reactor for the 5MW THR, certain new technologies were adopted for control and structure. Thus, the physical start-up experiments were also a comprehensive test of these new technologies and they provided data for heating reactor development and design directions. The physical start-up experiment work required strive safety guarantees to facilitate obtaining accurate and reliable data and information (for core loading, see Figure 2 in "5MW Experimental Nuclear Heating Reactor").

II. Preparations Prior to Physical Start-up

Given the importance of the physical start-up experiments and the fact that the 5MW THR was constructed as an initial test reactor, a great deal of theoretical calculations and experiment work were done prior to physical start-up. In the area of physics theory, we did critical quality calculations, reactivity calculations, control rod equivalent calculations, neutron flux distribution calculations, and so on. In the area of physics experiments, we first conducted a physical simulation experiment to measure critical quality, power distribution, control rod equivalents, reactor temperature coefficients, and so on. Then we carried out full-dimension core physical experiments and completed control rod differential and integral equivalent graduation, critical rod position measurements, one-fourth core neutron flux distribution and fission chamber graduation, and other experiments. This work provided reliable reference data for the first physical start-up. We also did the following preparatory work.

A. Hardware

The neutron source used in reactor start-up was a 3Ci Am-Be source. The neutron yield was 6.6×10^6 n/s. The external dimensions of the outer casing were $\phi 30 \times 6$ mm and the neutron source was installed on the outer side of the core at the central plane of the core. The calculations showed that the minimum counting rate of the neutron counter system prior to extrapolation was no less than 2 cps.

Before the reactor was loaded for the first time, the neutron source had already been installed in its predetermined location. The water level inside the pressure vessel exceeded the top of the core and loading was done in a situation where the water was present. During the stipulated loading process, three thermal neutron counting devices were used for monitoring and extrapolation. The installation sequences and positions for the fuel elements and element casings were provided in advance by physics personnel, while operating personnel formulated the rules for the first fuel loading.

To carry out monitoring and extrapolation, the design processed three temporary thermal neutron detector ports which extended directly at a site about 20 cm on the upper part of three small element casings on the corner of the core. The ports were formed of $\phi 28 \times 1$ mm (two) and $\phi 30 \times 0.5$ mm (one) stainless steel and the bottoms were welded to a stainless steel seal and there was a flange on the top part that was to seal and connect it with the top of the pressure vessel.

Four BF_3 thermal neutron detectors and three Li glass thermal neutron detectors with preamplifiers were prepared. They had a volume of $\phi 24 \times 250$ mm. The efficiency of the BF_3 detectors was 0.1 n/(s.unit flux) and the efficiency of the Li detectors was 1 n/(s.unit flux). The cables were 25 m long. Plateau characteristics and threshold characteristics were done for all of the detectors and long-term operating tests were carried out. They

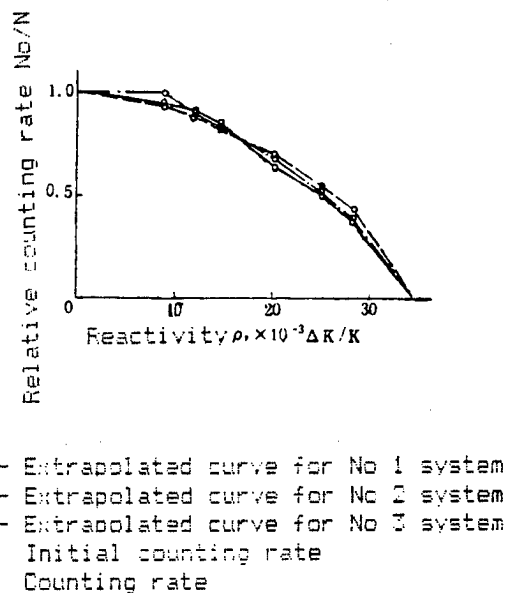

Figure 1. First Criticality Reactivity Extrapolation Curve

completely satisfied application requirements. Since the Am-Be neutron source did not have γ rays, this made it easy to use an Li glass thermal neutron detector during the first start-up and increased the efficiency of thermal neutron detection. Moreover, because the Li glass thermal neutron probe had a certain corresponding sensitivity to γ rays and non-thermal neutrons, its counting rate also included a certain component of fission γ counts and non-thermal neutron counts. Like thermal neutrons, the latter two counts also reflect changes in the reactor fission rate. As everyone knows, the γ flux distribution and moderate-energy neutron flux distribution are much flatter than the thermal neutron flux distribution, to the spatial location effects of this type of detector were much smaller. In other words, because the Li detector simultaneously monitored part of the γ and moderate-energy neutron flux, it had a more effective "field of view" than the BF_3 detectors which only monitored thermal neutrons. Changes in its counting rate more accurately reflected changes in the overall core fission rate. The start-up experiments confirmed that this greatly reduced the detector placement effects in the direction of the extrapolation curve (see Figure 1).

Four sets of (Nimu) machine boxes and plugs were used as counting devices and were connected to the thermal neutron detectors. Each set were composed of a low-voltage power source, high-voltage power source, linear amplifier, single channel, calibrator, and linear rate meter. They were capable of continuous 24-hour operation and their operation was stable and reliable.

"Reactor physical start-up procedures" were written and compiled on the basis of Nuclear Safety Bureau requirements and actual needs in the physical start-up. A curve of the control rod integral characteristics, a reactivity-cycle curve, and control rod lifting sequence and their reactivity input integral characteristics were plotted through a full-scale simulation experiment and checked through calculations (Figure 2).

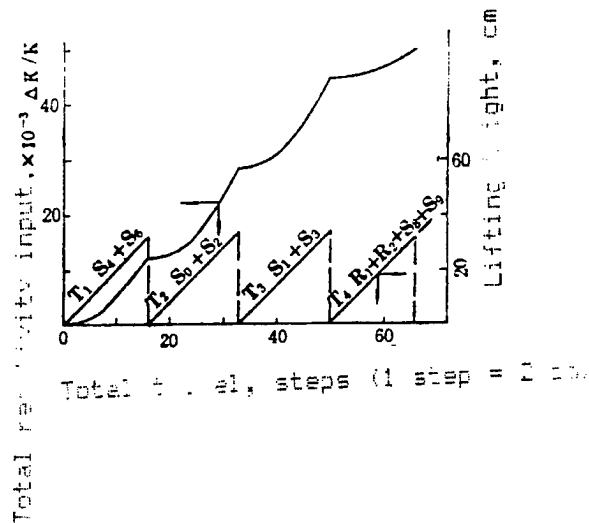

Figure 2. Extent of Control Rod Lifting and Reactivity Input Curve

To obtain accurate data, a reactivity graduation table was prepared for each group of control rods on the basis of control rod characteristics curves. Various recording tables for use in loading and start-up were also plotted.

III. Start-Up Experiment and Results

A. First loading of the reactor

The first loading of the reactor was carried out on 9 Oct 89. Before loading, the three sets of neutron counting systems used for monitoring and extrapolation (one Li detection system and two BF₃ detection systems) were first debugged on-site according to procedure and baseline neutron counts were recorded. The four small casing elements A₁, A₄, D₁, and D₄ were loaded first according to sequence and a neutron count was made. Then, C₂, C₃, B₂, and B₃ were loaded. A neutron count was made after each casing was loaded. The safety rod S_A was lifted. Then a neutron count was made for each of the casings that had been loaded and a critical element casing count was extrapolated to ensure that no supercriticality accidents occurred during loading. The loading sequence was C₁, D₂, D₃, B₁, A₂, A₃, B₄, and C₄. Figure 3 shows the Li detection system loading extrapolation curve and loading sequence.

It should be explained that during loading extrapolation, because of the substantial spatial effects, the reactivity input of each casing was also large, which resulted in rather substantial fluctuations in the extrapolation results from each set of extrapolation systems. The overall process, however, was smooth and successful. After loading was complete, the safety rod was lowered.

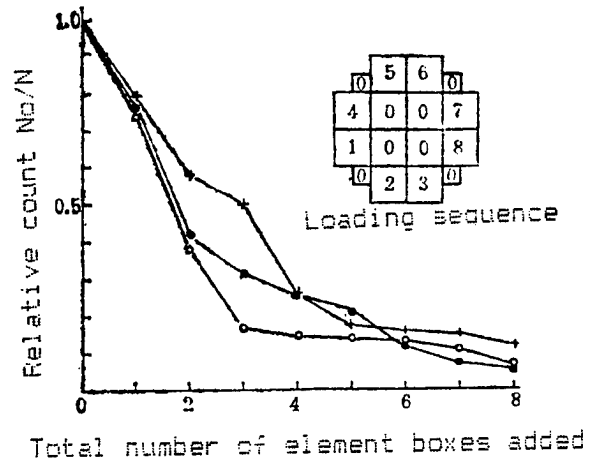

- - No 1 counting system (BF₃)
- - No 2 counting system (BF₃)
- - No 3 counting system (Li)

Figure 3. Loading Extrapolation Curve and Loading Sequence Diagram

Neutron counts were made before and after the safety rod was lowered.

B. First criticality of the reactor

The first criticality of the reactor was completed on 3 November 1989 under the supervision of the Nuclear Safety Bureau.

During the first criticality process, the control rods were divided into four groups. For safety reasons, the compensation rods S₅ and S₇ were locked in and not lifted during the start-up sequence. See Figure 2 in the article "5 MW Experimental Nuclear Heating Reactor" in this issue of HE DONGLI GONGCHENG for the numbers of the control rods. Figure 2 shows the control rod groupings and predetermined lifting height. The first criticality experiment used three sets of Li glass thermal neutron detector systems. This was done in consideration of their high counting rate and their advantages as described above. The actual process of extrapolation criticality and transition toward supercriticality for these three sets of systems are given in Table 1.

Table 1. First Criticality Control Rod Lifting and Extrapolated Subcriticality Boundary

Rod lifting order	Total Number of Steps to Lift Each Rod (1 Step = 2 cm)													Extrapolated Subcriticality Boundary, K%
	S _A	S ₀	S ₁	S ₂	cS ₃	S ₄	S ₅	S ₆	S _{f7}	S ₈	S ₉	R ₁	R ₂	
1	40					13		13						—
2						16		16						2.806
3		7		7										3.069
4		12		12										1.776
5		15		15										1.495
6		17		17										0.959
7			7		7									0.350
8			8		8									0.325
9			9		9									0.187
10										4	4	4	4	0.160
11										6	6			0.111
12												6	6	0.080
13										7				0.096
14											7			0.095
15												7		0.065
16													8	0.056
17										8	8			0.054
18										8	8	9		0.034
19													9	0.028
20										9				0.025
21											9			0.019
22												10	10	Multiplication Cycle > 300s
23	40	17	9	17	9	16	0	16	0	10	9	10	10	Multiplication Cycle = 230s

The actual lifting heights for each of the control rods prior to the transition to supercriticality are shown in Table 2.

Table 2. Actual Lifting Heights of Control Rods Prior to the Transition to Supercriticality

Rod group	Rod number	Number of steps	Lifting height, cm
T ₁	S ₄ , S ₆	16	32
T ₂	S ₀ , S ₂	17	34
T ₃	S ₁ , S ₃	9	18
T ₄	S ₈ , S ₉ , R ₁ , R ₂	9	18

At this time, the results from all the count extrapolation systems were identical and $k_{eff} = 0.998$. In the transition to supercriticality, R₁ and R₂ were raised to the 10th step and a multiplication cycle greater than 300 seconds was obtained. Then, S₈ was lifted to the 10th step and a multiplication cycle greater than 200 seconds was obtained. The extrapolation curves are shown in Figure 2.

C. Control rod levelling experiments

To obtain more operating experience and more experimental data, we conducted control rod levelling experiments. The rod lifting sequence and actual records of the transition to supercriticality are shown in Table 3.

Table 3. Control Rod Lifting and Extrapolated Subcriticality Boundaries for Control Rod Levelling Experiments

Rod lifting order	Total Number of Steps to Lift Each Rod (1 Step = 2 cm)													Extrapolated Subcriticality Boundary, K%
	S _A	S ₀	S ₁	S ₂	cS ₃	S ₄	S ₅	S ₆	S ₇	S ₈	S ₉	R ₁	R _{2set}	
1	40													—
2						14		14						8.419
3		14		14										2.148
4			12		12									0.467
5			13		13									0.238
6			14											0.164
7										5	5	5	5	0.068
8										7	7	7	7	—
9	40	14	14	14	13	14	0	14	0	9	9	9	9	Multiplication cycle 45 s

The control rod levelling experiments were conducted on 10 Nov 89. Table 4 shows the rod positions prior to the transition to supercriticality.

Table 4. Rod Positions Prior to Transition to Criticality and Supercriticality

Rod Number	Number of Steps	Lifting Height, cm
S ₀ , S ₁ , S ₂ , S ₄ , S ₆	14	28
S ₃	13	26
S ₈ , S ₉ , R ₁ , R ₂	7	14

At this time, $k_{\text{eff}} = 0.9993$. R₁, R₂, S₈, and S₉ were lifted to the 9th step and a multiplication cycle of 45 seconds was obtained.

Design, Experimental Research of Hydraulic Control Rod Drive System for 5 MW THR

916B0017D Chengdu HE DONGLI GONGCHENG
[NUCLEAR POWER ENGINEERING] in Chinese
Vol 11, No 5, 10 Oct 90 pp 73-76

[Article by Wu Yuanqiang [0702 0337 1730], Hu Yuedong [5170 2588 2639], Cheng Yunsheng [4453 0061 0581], Yang Nianzu [2799 2214 4371], Liu Chengying [0491 2052 3379], and Zhang Fulu [1728 4395 6922] of the Qinghua University Nuclear Energy Technology Institute, Beijing; manuscript received 23 Apr 90]

[Text]

Abstract: A control rod hydraulic drive system is a new type of drive device different from the electromagnetic-mechanical drive systems used in regular hydraulic drive reactors. It uses the reactor coolant (water) as a working medium. After pressurization by a pump, it is injected into a hydraulic step cylinder installed in the pressure vessel and uses flow rate to control the step movement and pulling of the outer casing of the hydraulic step cylinder and the neutron absorption elements connected to it. The 5MW THR is the world's first reactor to use

this type of drive. This drive was adopted to provide better safety characteristics, more reliable drive characteristics, and excellent economy.

Key words: 5MW experimental low-temperature nuclear heating reactor, hydraulic step cylinder, control unit, combined valve.

I. Outline

The 5MW THR uses a hydraulic step drive instead of the traditional electromagnetic-mechanical drives used in hydraulic reactors to drive 13 control rods. This mainly serves to provide more reliable and safer drive characteristics, and it was done to ensure that the natural circulation in the reactor's main loop is not affected by the control drive structure. Moreover, in a small reactor with a pressure vessel that is just 2 m in diameter, there is an extremely acute space conflict involved in installing 13 sets of drive structures on the top of the reactor. This is another reason that the hydraulic drive was adopted.

"Hydraulic drive" is different from the hydrodynamic concept of "hydraulics". It is a type of dynamic pressure drive, meaning that passes through at a specific flow rate through the resistance girdle between the piston and the cylinder, it creates a pressure differential on both sides of the piston and relies on this pressure differential to either push or maintain the position of the piston. "Hydraulic drive" can only exist in a fluid and when the flow rate is 0, the pressure differential is 0 and the push is 0.

In the 5MW THR, we utilized this principle to develop a dual-port hydraulic step cylinder and used it as a core for developing a full set of control rod drive systems^[1]. This article will introduce the theory behind the hydraulic step cylinder and the main links in the system and system development and experimental research work.

II. Operation Principles of the Dual-Port Hydraulic Step Cylinder

The dual-port hydraulic step cylinder is composed of an inner sleeve, outer casing, neutron absorption body (Figure 1). The inner sleeve is a fixed sleeve and the outer casing is a moveable casing. The inner sleeve is full of rows of oval holes. Each row has four holes evenly distributed around the circumference. The distance between each row is the step distance. There is a row of corresponding round holes on the outer casing and the outer casing is affixed to the pulling target. The entire cylinder is installed vertically within a water-filled container. The water is drawn out of the container and into the inner sleeve of the cylinder by pump pressurization and sprays into the container through the holes in the inner sleeve and outer casing. As the flow rate increases, when it reaches a certain flow rate Q_{min} , the outer casing begins to float upward. As the incoming flow rate increases, the outer casing floats ever-higher and when the inner sleeve and outer casing are fully opposite each other, the flow rate is Q_{max} (Figure 2). When the flow rate is greater than Q_{max} , the outer casing can no longer be held stable and is pushed upward.

The control principles for the dual-port hydraulic cylinder are illustrated in Figure 3.

1. Holding state. The lifting electromagnetic valve 1 is opened and the lowering electromagnetic valve 3 is

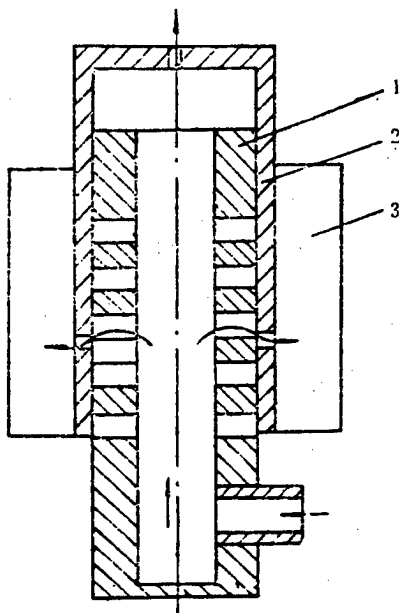

Figure 1. Principles of Hydraulic Stepping Cylinder
Key: 1. Inner sleeve; 2. Outer casing; 3. Absorption body

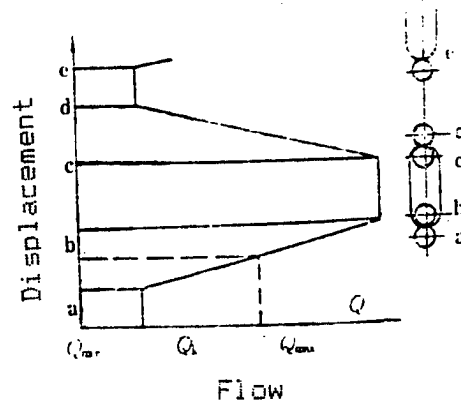

Figure 2. Static Characteristics of Hydraulic Stepping Cylinder

(The left side of the diagram shows the relative displacement of the flow regulation holes, which correspond to points a, b, c, d, and e on the vertical grid.)

closed. The water from the pump outlet passes through throttle port 4 and into the step cylinder. This flow rate sustains the flow rate Q_K and meets $Q_{min} < Q_K < Q_{max}$. At this time, the outer casing can be held at a specific position.

2. Lifting state. The lifting operation is performed by electromagnetic valve 1 and pulse valve 2. Lowering valve 3 remains closed. Pulse valve 2 is a cylinder containing a piston. In the holding state, the pressure P_A at the top of the piston is greater than the pressure P_C at the bottom of the piston, that is, $P_A > P_C$ and the piston is in a lower position. When the lifting operation begins, electromagnetic valve 1 closes and P is connected with the pump inlet through the position return throttle port 6, $P_A < P_C$, and the piston moves upward to the top position. Then valve 1 opens suddenly and the piston moves downward and injects the flow rate ΔQ toward the water intake pipe and on to the end of the process. If $\Delta Q + Q_K > Q_{max}$, the process is appropriate and step can be achieved. Use of the pulse valve ensures that the system will not suffer any type of direct connection with the pump outlet and only a limited amount of water enters the step cylinder during each operation.

3. Lowering state. In the holding state, when the lowering electromagnetic valve 2 is opened and maintains isolation for a period of time Δt , a substantial portion of Q_K passes through valve 3 and returns to the pump inlet, $Q_K - \Delta Q < Q_{min}$ and the step cylinder moves it downward. The length of the control time Δt can achieve stepped or continuous lowering.

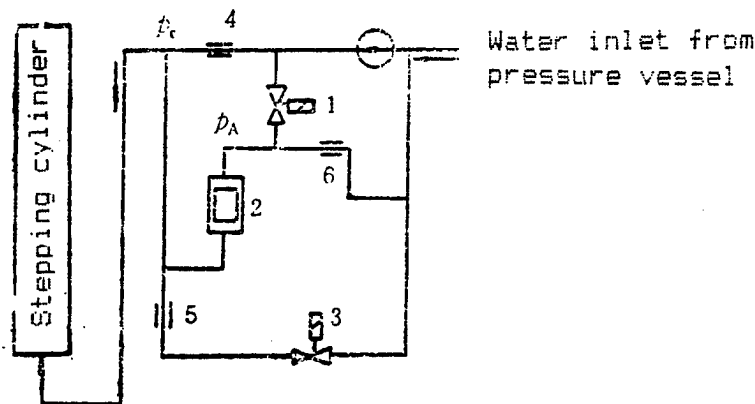

- 1 - Lifting electromagnetic valve (normally closed)
- 2 - Pulse valve
- 3 - Lowering electromagnetic valve (normally open)
- 4 - Maintain flow regulation hole
- 5 - Rising flow regulation hole
- 6 - Position return flow regulation hole

Figure 3. Diagram of Control System Principles

III. Primary System Equipment

A. Hydraulic step cylinder assembly

The hydraulic step cylinder assembly includes the sleeve assembly, outer casing assembly, absorber side plate assembly, and socket. The sleeve includes an upper and lower segment. The lower section is made of Zr-4 and its bottom tip is inserted into the socket. The upper section is the sleeve of the hydraulic step cylinder and there are 40 rows of throttle ports on the upper surface spaced at the step distance (20 mm). The total length is 800 mm. The outer casing assembly is composed of three segments, all of which are made of stainless steel. An absorber side plate is installed at a 90° angle on the outside of the lower section. The middle section has throttle ports, and the tip of the upper part is an ultrasonic reflection surface and buffer device. Structure of the absorber side plate: a sintered B_4C core plate is welded inside a stainless steel pipe and the outer surface is wrapped in stainless steel to form the absorber side plate. The socket is the fixed support socket for the sleeve as well as the water inlet, and a terminal buffer is installed on the socket.

B. Control system equipment and combined valve

The main parameters for the control rod hydraulic drive control system are as follows: the system's maximum working pressure is 2.35 MPa; the water pump lift is 90 m; the working flow rate is 13 to 15 tons/hours; the water temperature is room temperature to 186° C.

The system water intake port is placed at the outlet of the primary heat exchanger to enable the water in the system to have rather substantial over-cooling and avoid local vaporization in the system. After passing through the containment vessel, it enters the equipment chamber and is intensively cooled through over-cooling, and enters the primary circulation pump. The primary circulation pump is a screened centrifugal pump and there are two in the system, one for operation and one for reserve use. After pressurization, the water passes through a filter and after its pressure is regulated, it flows again through the containment vessel and into the combined valve inlet.

The combined valve is a large forged component. Its upper surface is formed of 6 to 7 control elements and boring is substituted for a connecting pipe to increase system reliability and reduce the number of pipes passing through the containment vessel. The combined valve is placed inside the containment vessel and connected to the pressure vessel with a flange. This reactor has two combined valves. The bottom end of the combined valve has 13 water outlet interfaces that are connected by flanges to the hydraulic step cylinder water inlet pipe inside the reactor. A backflow prevention valve is installed on the inlet of the combined valve to prevent large amounts of water inside the pressure vessel from entering the safety valve in the event of a pipe rupture and loss of pressure.

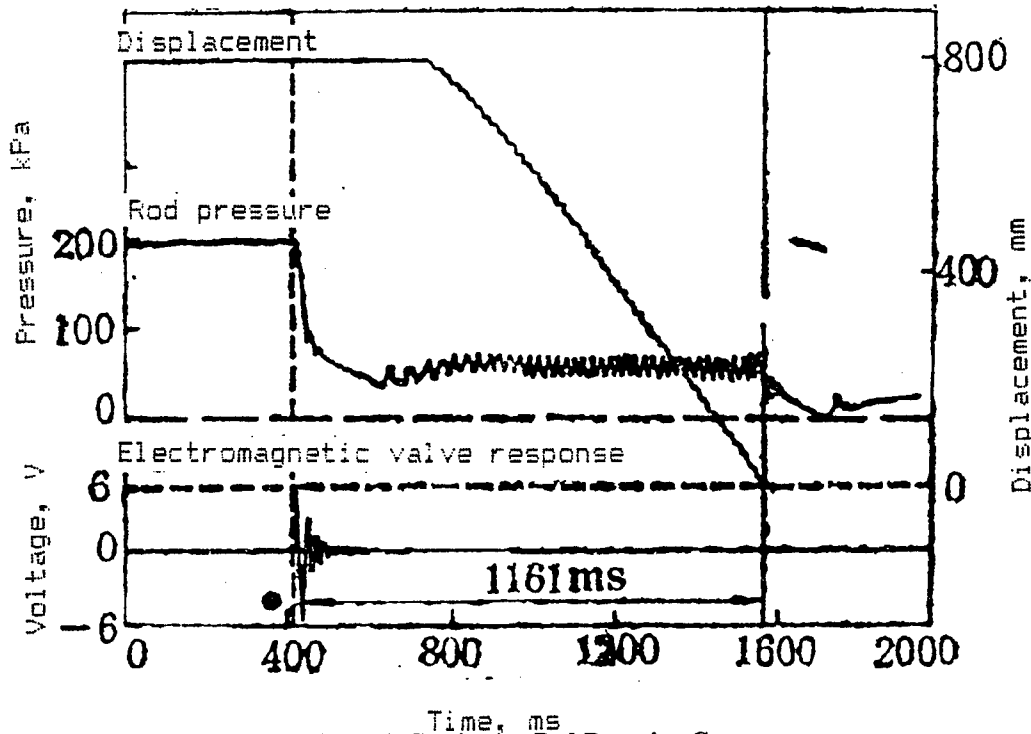

Figure 4. Continuous Rod Dropping Curve

IV. System Experimental Research

Development and experimental research on the control rod hydraulic drive system began in early 1985 and lifespan experiments were completed at the end of 1988, taking a total of 4 years. Five large experimental consoles were constructed. They were a single rod cold state experiment console, single element hot state experiment console, cold state multiple rod comprehensive experiment console, dual rod hot state experiment console, and combined valve experiment console.

A. Cold state and hot state hydraulic properties experiment

This experiment was carried out on the single rod cold state and hot state experiment consoles. When it changed from room temperature to the rated temperature, the density of the water dropped by about 15 percent and the viscosity of the water dropped by about 88 percent. This undoubtedly will create rather substantial effects on the characteristics of the hydraulic step cylinder which uses water pressure as a drive. The goal of this experiment was to study the static and dynamic characteristics of the hydraulic step cylinder when temperatures changed and to make a final determination of the overall characteristics that were not temperature-sensitive. The experiment showed that the system could operate at a temperature range from room temperature to 200° C. The second part of the experiment involved measurement of transient state processes during cylinder operation and included

lifting, lowering, and sustained rod lowering processes. The measurements were made on a 3655 analysis recorder. Figure 4 shows the sustained rod lowering curves. Curve 1 is the displacement signal and Curve 2 is the pressure curve within the cylinder.

B. Lifespan tests for the control rods

To ensure the safety and reliable operation of the control rods during their expected lifespan, the control rods were put through repeated operation tests from cold state start-up to hot operation along with continuous lifespan tests and reactor shutdown safety tests. These tests were carried out on the dual rod high temperature experiment console and the system operating parameters were entered into a computer data collection system. During the operation tests for 101,450 steps:

1. The number of operation errors in over-lifting by 1 step was 0;
- 2) The number of other safety error operations was 9, including 1 time for lifting 0 steps, 6 times for lowering 0 steps, and 2 times for lowering 2 steps.

The overall breakdown rate was 9×10^{-5} and there were no seize-up phenomena. The variation in rod lowering speed was less than 5 percent. The terminal end buffer worked normally and the terminal equilibrium position was moved $< 1 \text{ mm}^*$.

V. Conclusion

1. After theoretical analysis and experimental research, the hydraulic step system has now been successfully used in the 5 MW THR and the rationality and practicality of the system design and the hydraulic step cylinder design have been confirmed.

2. The working temperature range of the system is 20 to 200° C. No adjustment of system parameters is required within this range.

3. Analysis of the system shows that the hydraulic step drive has the following advantages: 1) Accident safety; 2) Short operating links, high reliability; 3) Simplified reactor-top drive structure, reduced total costs; 4) Inexpensive manufacturing costs. Its disadvantages are: a) Rather small thrust; b) Slower response speed. Overall, it is a new type of control rod drive system that has substantial development prospects and will have a definite influence on reactor safety and structural design.

Footnotes

* Design operating lifespan \approx 10,000 steps, design number of rod drops \approx 60.

[1] Wu Yuanqiang [0702 0337 1730], et al., Patent No 100042, 1985.

Safety Analysis, Evaluation of Hydraulic Control Rod Drive System in 5MW THR

916B0017E Chengdu HE DONGLI GONGCHENG
[NUCLEAR POWER ENGINEERING] in Chinese
Vol 11, No 5, 10 Oct 90 pp 77-80

[Article by Hu Yuedong [5170 2588 2639], Wu Yuanqiang [0702 0337 1730], Liu Chengying [0491 2052 3379], Cheng Yunsheng [4453 0061 0581], An Jian [1344 1696], and Dong Yonggui [5516 3057 6311] of the Qinghua University Nuclear Energy Technology Institute, Beijing; initial draft received 23 Apr 90, revised draft received 20 May 90]

[Text]

Abstract: The 5MW THR uses a new type of control rod hydraulic drive system and this article makes a comprehensive analysis of the safety characteristics of the system. The design of this system is based on a passive system and it achieves integration of drive and guide, so the system has reliable inherent safety properties and can ensure safe reactor shutdown under any type of accident conditions.

Key words: 5MW low-temperature nuclear heating reactor, control rod, hydraulic drive, passive system, inherent safety features.

I. Safety Analysis of Control Rod Hydraulic Drive System

The functions of a reactor control rod hydraulic drive system are: under normal operating conditions, moderate power accident conditions, and rare accident conditions, to be able to safely and normally control the reactor's reactivity and power distribution and to ensure reliable reactor shutdown functions under these conditions. To achieve and satisfy this criterion, the 5 MW THR employs a new type of control rod hydraulic drive system HCRDS (see "Design and Experimental Research on the 5MW THR Control Rod Hydraulic Drive System" in this issue). This article will analyze the inherent safety of the HCRDS in three areas.

A. The HCRDS can satisfy the requirements for reliable and safe reactor shutdown

Safety reactor shutdown operations in this reactor are done by the HCRDS not stopping the pumps and shutting off power to the lowering valves, or by stopping the pumps and cutting off power to the lowering valves so that the 13 rods are inserted simultaneously into the core. The reliability of its operation is an inherent safety feature provided by the HCRDS passive system and is guaranteed by integration of drive and guides.

The primary characteristics of the HCRDS as a passive system are:

1. Rising pressures in the pumps is the only source of power which drives the operation of the control rods and it is the highest pressure in the entire reactor. The force on the control rods is a "soft" drive.

2. The control rods themselves have an inherent capacity for leaking water and leaking pressure. Their inner cavities are connected to the pressure vessel by the air discharge hole, labyrinth gap, and dual ports.

3. The lowering valves for each of the control rods are normally open electromagnetic valves. The valves close naturally when there is merely a power shutoff and a pressure differential exists between the inner cavity of the rods and the pressure vessel. This provides a sufficient water leakage and pressure leakage capacity for the control rods and can ensure that the pressure in the inner cavity of the control rods is always in basic equilibrium with the pressure in the pressure vessel.

This shows that the lifting and holding of the control rods are determined by whether or not the pressure in the inner cavity is able to satisfy the equilibrium pressure that is greater than or equal to that required by the weight of the rods themselves. As soon as the pressure in the inner cavity is lost due to various factors or is less than the equilibrium pressure, this means that the self-unlocking constraints which limit the insertion of the control rods into the core. No power is required for this unlocking nor does it require any type of mechanical drive. At this instant, the maximum force on the control rods is only the weight of the rods themselves. Under the

effects of this, the control rods are inevitably inserted straight down to the bottom and maintain the reactor in a shutdown state.

It is quite apparent that under accident conditions, when a power grid outage, HCRDS power outage, and HCRDS destruction or failure occur, it causes automatic locking of the control rods and the reactor is safely shut down. In a reactor accident safety shutdown, the effects of the HCRDS on the protection system are quickly completed. However, it is not sufficient to rely only on the inherent safety characteristics of the HCRDS for a safe reactor shutdown. There must also be sufficient guarantees of the mechanical reliability of the drive structure, so this reactor uses a design which integrates the control rod drive and core structure.

Because the control rods have a hydraulic drive and use ultrasound for position determination, the control rods can be installed within the + shaped space for by the four element boxes and placed with the element boxes in a fixed installation on the same grid. The mechanical drive chain for each rod is very short and the drive period allows a sufficient interval. In this way, full-stroke guidance for the control rods is achieved by relying only on the length of the element boxes and there are no problems of guidance or alignment when the control rods are inserted into the core. For the pressure vessel margin, there is no problem with piercing the vessel seal, so as a result there is an extremely large increase in the reliability of the control rod drive, which prevents seizing of the mechanical drive over long distances and ensures the integrity of the pressure margin screening.

The integrated design for the drive structure and core and its excellent integrity give it excellent earthquake-resistance capabilities. Earthquake resistance calculations show that the control rods cannot be broken or fail during earthquakes and the maximum believable accident due to an earthquake is a power outage and the destruction and failure of the external HCRDS equipment and pipelines. Thus, all of the rods can drop simultaneously and be inserted into the core to shut down the reactor. If by chance one rod fails, it can still physically ensure that the neutron chain reaction in the reactor does not continue.

In summary, the HCRDS of the 5MW THR satisfies reliable and safe reactor shutdown requirements.

B. The reactor shutdown effects of HCRDS in a reactor failure accident

Because the control rods do not require power unlocking and drive, changes in the drive operating state are caused by changes in the pressure of the inner cavity, while the transfer time for changes in pressure can be ignored. Thus, the effects of control rod insertion into the core are related only to the selection of the transmission of the protection signal, pump inertia, the time it takes to open the primary valve cores for the lowering valves, and the lowering resistance coefficient. Measurements indicate

that from the time an accident occurs until the protection signal is activated and causes a power shutoff to the electromagnetic valves and water pumps takes just 10-plus or several 10 milliseconds. Because of the lag in rod dropping due to the pump inertia and the time required to open the primary valve cores of the lowering valves, the overall effect is that the time lag is less than 200 to 300 milliseconds. The insertion speed of the control rods is related to the size of the lowering resistance coefficients selected. The smaller the resistance coefficient, the more rapid the water leakage and the faster the insertion speed. Actual operation has shown that the reactor shutdown response speed of the HCRDS hydraulic drive in this reactor is completely capable of satisfying reactor safety requirements.

To further analyze the safety characteristics of the HCRDS, we did rod dropping tests for the control rods under the most conservative working conditions. Achievement of this type of rod dropping relied entirely on the inherent water leakage and pressure leakage of the rods themselves. The experiments were carried out under normal HCRDS operation, abrupt closure of the pneumatic isolation valves, and unopened lowering valve working conditions. The results showed that under these types of working conditions, the total response time of rod dropping still did not exceed the time period restricted by the safety requirements of this reactor. In addition, these experiments also directly confirmed the inherent reactor shutdown safety features of the control rods, so regardless of what type of working condition appears, by simply relying on the loss of drive pressure in the inner cavity pressure, the control rods are always inserted to the bottom and eventually stop reactor operation.

3. The HCRDS hydraulic drive cannot cause flexible rod accidents

The mechanism by which the HCRDS hydraulic drive causes flexible rods is caused by the creation of an uncontrollable internal pressure that is greater than the pressure from the weight of the control rods themselves during a rather long sustained time period due to the inner cavity of the control rods. If this possibility was eliminated in the system design and the system could provide the conditions for restricting or releasing the internal pressure under expected working conditions, there would be no rod flexibility in the control rods. The design of the HCRDS strictly observes this principle and used experimental operation and engineering operation to confirm the inherent safety that the HCRDS hydraulic drive control rods would not create flexible rod accidents under any type of working conditions.

1. Safety analysis for maintaining the state of control rod equilibrium internal pressure. Maintaining a state refers to holding a control rod stable at a certain position with the inner pressure of the control rod being equal to the pressure of its own weight. During operation, the equilibrium pressure is stable because: 1) The fixed value of the control rod equilibrium inner pressure is determined

by the inherent mechanical characteristics of the rods. Equilibrium inner pressure is achieved by pump and pipeline characteristics. 2) The hydraulic characteristics of the control rods guarantee that the equilibrium pressure in the inner cavity of the rods has sufficiently ample self-regulation capabilities, meaning that at the maintained position of the control rods, variations in dual-port resistance coefficients permit the maintained flow rate to vary over a very wide range without destroying the equilibrium pressure. The ratio between the maximum and minimum flow rate can be several 100 percent. This cannot create such large variations in the non-regulated systems in an operation.

Moreover, the design of the HCRDS adopts the following measures: 1) The loop pressure and working values near or associated with the HCRDS are always smaller than the working pressure of the HCRDS itself and under operation conditions are not larger than the water intake port pressure of the system circulation pumps. This ensures that the control rod drive structure cannot cause destruction of the equilibrium pressure because of a rupture in auxiliary system pipelines. 2) The HCRDS has pressure stabilization devices installed and there are no design links which can cause pressure lag effects. This gives the HCRDS excellent tracking properties for the pressure in the pressure vessel and ensures that the control rod drive structure cannot cause destruction of the equilibrium pressure because of pressure fluctuations in the pressure vessel.

Analysis shows that when the control rods are in a maintain state, maintaining the equilibrium pressure is ensured by the inherent safety characteristics of the rods themselves. No internal pressures greater than the equilibrium pressure are created and the control rods cannot cause flexible rods or extreme accidents.

2. Safety analysis of drive state control rod hydraulic drive pressure. The drive pressure when the control rods are lifted come from the high pressure of the pumps but because of the isolation role and fixed quantity output of the pulse valves, the rising valves are only able to close and open reliably one time for the control rods to be able to be lifted once and rise one step. During this process, the high pressure obtained in the inner cavity of the rods is only transient and the peak value is limited, so it cannot cause lifting in excess of the step distance during lifting and the control rods cannot be flexible rods, so this effectively controls the input amount of positive reactivity and prevents unacceptable reactor transient states. As for rod dropping action, its drive is safe working conditions, so no further analysis will be done.

3. Safety analysis of loss of pressure accident dropped control rods. Because of the inherent safety characteristics and excellent tracking characteristics of the HCRDS, and because the water phase entering the drive system is always a fixed depth of over-cooled water for the pressure of the pressure vessel, when a loss of pressure accident occurs in the pressure vessel, as long as the pressure in the pressure vessel is still no lower than the

saturated steam pressure required by the water temperature of the hydraulic drive system to reduce the rod equilibrium pressure differential, no uncontrollable or sustained action rod pressure greater than the equilibrium pressure can be created in the inner cavity of the control rod, so rod flexibility cannot occur in the control rods. Under believable loss of pressure accidents, the speed of the pressure loss is restricted by the critical flow, so the speed of the pressure loss is rather slow. If the pressure in the pressure vessel is lower than the saturated steam pressure required by the temperature of the hydraulic drive system and reduces the equilibrium pressure differential, estimates indicate that after a few 10 seconds to 100 seconds, under these conditions, the protection system would have the complete conditions for a safe reactor shutdown and all of the control rods would drop rapidly because of the pump shutdown and opening of the lowering valves and sustain a reactor shutdown. At this time, because the lowering valves are already in their normally-open state, this would greatly increase the pressure leakage capabilities of the control rods. The result would be that, during the entire loss of pressure process, the internal pressure of the control rods would reduce the pressure in the pressure vessel and it could not be greater than the equilibrium pressure, so the control rods could not cause rod flexibility. In reality, because of heat convection inside and outside of the rods in conjunction with the release of latent heat from vaporization, the water temperature in the rods would drop, so the differential in the water temperature inside and outside the rods could not be very great and it would be difficult for a saturated steam pressure differential greater than the equilibrium pressure to form. This means that a definite additional pressure could be created in the rods and this would cause the pressure created to leak out and drop because of the natural opening of the lowering valves and the inherent pressure leakage capabilities of the rods.

To confirm this analysis, we conducted control rod loss of pressure experiments in a pressure vessel simulator 3.4 m high and 280 mm in diameter. No rod flexibility occurred either in a man-made accident or a destructive pressure loss, meaning that the pumps did not shut down and the rods were still lifted in the initial stages of the pressure loss, and there was no rod flexibility.

II. Comprehensive Evaluation of the Control Rod Hydraulic Drive System

1. Long-term experiments and formal operation of the control rod hydraulic drive system indicated that the system was reliable and was capable of achieving a safe reactor shutdown.

2. The measures adopted in the HCRDS can effectively prevent large inputs of positive reactivity and can prevent extreme accidents.

3. When a power outage or system equipment destruction and failure occurs, the failure safety features of the

HCRDS can enable a safe shutdown of the reactor and ensure the integrity of the pressure-bearing margin screening.

4. Under expected working conditions, HCRDS can reliably achieve reactor control and regulation and satisfy heat supply and other uses.

Fuel Assembly of the 5MW THR

916B0017F Chengdu HE DONGLI GONGCHENG
[NUCLEAR POWER ENGINEERING] in Chinese
Vol 11, No 5, 10 Oct 90 pp 85-89

[Article by Xu Yong [1776 0516] and Zhang Zhensheng [1728 2182 5116] of the Qinghua University Nuclear Energy Technology Institute, Beijing; manuscript received 23 Apr 90]

[Text]

Abstract: This article introduces the design principles, design characteristics, and structure of the fuel assemblies in the 5MW THR. It also analyzes and evaluates their performance.

Key words: 5MW experimental low-temperature nuclear heating reactor, fuel assemblies, fuel rods, design characteristics, performance analysis.

Zero-power reactor test operation and formal operation in the reactor for more than 3 months have confirmed the excellent performance of the fuel assemblies in the 5MW THR. This article will provide a brief introduction to the design features of the fuel assemblies and analyze their performance.

I. Mechanical Design

A. Structural design

Embodying the principles of self-reliance and basing oneself on domestic strengths, the fuel assemblies in the 5MW THR adopted rod diameters and cladding materials similar to the fuel rods in the Qinshan Nuclear Power Plant. Because the 5MW THR is an experimental reactor and must work in both pressurized water and micro-boiling working conditions, the design for the fuel assemblies on the one hand adopted the slender rods of a pressurized-water reactor and on the other hand adopted the small rod bundle boxed assemblies of regular boiling-water reactors. The fuel assemblies contain two parts. One part is the arrangement of the fuel rods (fixed rods and standard rods) and burnable poison rods in 10 X 10 or 6 X 6 square columns and rows that are connected and affixed to upper and lower grid plates to form fuel rod bundles. The other part is fuel assembly box sets that are formed by a mechanical linkage of square zirconium boxes and pipe spouts. The fuel rod bundles are inserted into the box sets and their lower grid plate sockets are on the pipe spouts and spring plates affixed to the top grid plate support them on the box sets. The rod bundles and box sets are assembled to make the fuel assemblies (see Figure 1 for more detail). This type

of insertable core fuel assemblies that are inserted in layers facilitate installation and replacement and the box sets can be used for long periods. The debugging process for this reactor confirmed that before the fuel rod bundles are assembled and inserted, full installation of the internal components of the reactor can be carried out and debugging operation done for the + shaped control rod cold and hot states. This greatly improves the flexibility in debugging the reactor. The entire fuel loading process showed that the loading operations for the fuel assemblies having this type of structure is easy and highly reliable.

As shown in Figure 1, the rod bundles include upper pipe seats, lower grid plates, fuel rods (burnable poison rods), and their fasteners. The end caps on both ends of the fixed rods are threaded and these rods and their nuts are used as connectors to assemble the upper and lower grid plates and other fuel rods into an integrated rod bundle. Locking measures are used on all the threaded connectors on the fixed rods and the guide nuts are positioned on the four outer sides of the lower part of the rod bundles, which aids in alignment of the long-distance hoists and can prevent damage to the fuel rods by collision during the transport process. The burnable poison rods with long end caps aid in identification and determination of their positions. There is a compressed spring in the axial space between the upper end caps on the standard rods and the upper grid plate to prevent axial expulsion of the fuel rods in the rod bundles during transport. The $\phi 6$ positioning column surfaces on the upper and lower end caps of the fuel rods are connected to precision-processed positioning holes on the upper and lower grid plates to ensure the rod gaps and play a role in positioning during lifting of the fuel rods. The axial positioning of the rod bundles is guaranteed by the positioning length of the fixed rods. The 6 X 6 small rod bundles and 10 X 10 large rod bundles have similar structures. The only difference is that the former has fewer fixed rods than the latter.

The upper pipe seat includes the upper grid plate and a hoist handle. The positioning holes are arranged in a 13.3 X 13.3 mm square of columns and rows and the spaces between the holes are connected together to help form a flow channel for the coolant. The cross-section of the flow channel accounts for 49 percent of the grid plate. The shape of the lower grid plate is identical to that of the upper grid plate but it is slightly thicker so the cross-section of the water flow holes is slightly smaller. In addition, rod bundle positioning guide grooves are placed on the four corners of the lower grid plate.

The fuel rods have Zr-4 alloy cladding and slightly enriched UO_2 powder that has undergone high-temperature sintering composes the ceramic core blocks with a theoretical concentration of 95 percent. This type of ceramic fuel core blocks has excellent stability and high melting point, and good compatibility with water and zirconium. The core blocks use concave butterfly-shaped round columns, which greatly improves the high temperature properties of the core blocks and reduces

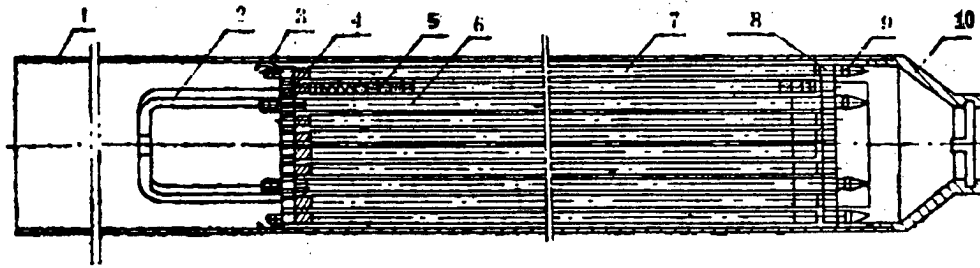

- 1 - Zirconium box
- 2 - Hoist clamp
- 3 - Spring plate
- 4 - Upper grid plate
- 5 - Fuel core blocks
- 6 - Standard rod
- 7 - Fixed rod
- 8 - Lower grid plate
- 9 - Guide bolt
- 10 - Pipe spout

Figure 1. Fuel Assembly

interaction between the core blocks and the cladding. The core blocks of the burnable poison rods are made of UO_2 core blocks mixed with Gd_2UO_2 and there is an Al_2O_3 heat shield on the upper and lower ends of the core blocks to conduct heat in an axial direction in the fuel rods. There is a specific gap between the core blocks and the cladding and a specific space is left at the top, which both avoids effects on the cladding caused by swelling and heat expansion and leaves a sufficient stationary cavity for the fission gas. A compressed spring is installed in the upper cavity to eliminate thermal expansion stress on the core blocks and prevent free sliding of the core blocks during transport. A small hole is left at the top of the fuel rods and vacuum pumping is carried out and they are filled with high-purity helium gas to 0.196 MPa after the end caps are welded on. Zr-4 alloy end caps are welded on to seal both ends of the fuel rods.

The fuel assembly box sets are composed of a zirconium box and stainless steel pipe spout that are mechanically linked. The material in the zirconium boxes is Zr-4 and they have walls 1.5 mm thick. The function of the box sets is: 1) To serve as separation devices for the coolant flow channels between boxes and between the inside and outside of the boxes which helps in flow rate regulation in different flow channels; 2) To support as support and positioning devices for the fuel rod bundles; 3) The cracks between the box sets serve as drive channels for the control rods and are support and guide devices inside the control rods (because they require high-precision processing of the zirconium boxes and pipe spouts and strict assembly); 4) Independent box sets facilitate in

installation and debugging of components inside the reactor and can extend their operational lifespan.

B. Performance analysis

We mainly use the FRAPCON-2 and FRAP-T6 programs recommended by the United States Nuclear Regulatory Commission for the performance of the fuel rods to carry out calculations and analysis. The results showed that under heating reactor conditions and in particular under 5MW application conditions, the existing fuel rods have a substantial safety margin.

1. The fuel rods operate under low-temperature, low-pressure, and low power density working conditions. During normal operation, the temperature of the cladding at hot points on the fuel rods is below 200°C and the core temperature of the fuel core blocks is no higher than $1,100^\circ\text{C}$. The maximum external pressure is 1.47 MPa. While considering axial, radial, and local peak value factors, we also took into consideration engineering factors and specific safety factors. The rated linear power density of the fuel rods was 28 kW/m, but the average value was just 5.61 kW/m. Under accident conditions, the temperature of the fuel rod cladding would be less than 300°C while the central temperature would be $1,385^\circ\text{C}$, so the average temperature of the fuel rods is only about 400°C .

2. There is very little deformation and stress of the fuel rod cladding. Under all working conditions, the stress on the cladding allows using a one numerical grade-lower stress, meaning that when they reach high fuel consumption of 30,000 MW.d/t(U), the permanent deformation of the cladding would be -0.01 percent in the radial

direction and 0.15 percent in the axial direction while the maximum deformation during operation would not exceed 0.2 percent.

3. During the operation period, the internal pressure of the fuel rods and their fission gas release rate would be very low. Although there are definite differences between the computed simulations in this area, within a fuel consumption of 30,000 MW.d/t(U), the fission gas release rate would generally be less than 1 percent whereas the internal pressure in the rods would always be less than the 14.7 MPa coolant pressure.

4. The irradiation expansion of the fuel is less than 0.8 percent whereas the density ratio is less than 0.7 percent. Contact between the core blocks and the cladding cannot occur during the fuel consumption period in the 5MW THR, which means that a relatively high fuel consumption (for example, 30,000 MW.d/(tU) would not result in interaction of the core blocks and cladding.

5. The results of computations show that under 5MW THR conditions, or in other words in a heating reactor environment, oxidation of the cladding can be ignored while hydrogenation would reach 14.4 ppm.

Besides these properties of the fuel rods, other methods were also used to compute and analyze stress and deformation due to external pressure on the rods, structural discontinuity, temperature field changes, and other factors. The results showed that whether in a stable state or in various types of transient states (including accident working conditions), the fuel rods are safe in all cases.

The SAP-5 program was employed for analysis of the earthquake frequency spectrum response of the fuel rod bundles and to analyze the effects of vibrations induced by (Aiersheng) yield waves under reactor safety shutdown earthquakes and on-site artificially synthesized waves. Of course, the effects on the rod bundles are transmitted to the fuel assemblies and their rod bundles through the plant site, containment vessel, pressure vessel, and components inside the reactor. In the calculations, we used different models to analyze the vibration induced effects on single rods and rod bundles. The results showed that rank-one induced vibration effects are the primary ones while rod-to-rod vibrations are homophasic. The maximum amplitude 2.97 mm, the stress is 11.2 MPa, and no deformation would occur in the rod bundles during the vibration that would prevent the insertion of control rods into the zirconium boxes.

The analysis shows that during normal operation, the maximum amplitude of the hydrodynamically-induced vibrations on the rod bundles caused by the flow of coolant is just 0.05 mm, which is far smaller than the rod bundle assembly tolerance, their stress can be ignored as well.

Careful analysis also was done of the stress on the rod bundles during transport and we conducted hoist experiments. These fully guaranteed reliable operation of the fuel rod bundles during the loading and unloading process.

II. Nuclear Design

The fuel assemblies for the 5MW THR core (see Figure 2 in the article "The 5 MW Experimental Nuclear Heating Reactor" in this issue) are configured in three regions. The four central boxes are one region. Two boxes next to each side on the outer sides of these four boxes (a total of eight boxes) are the second region. At the four corners of the second region, four small 6 X 6 assemblies are used to reduce neutron leakage. This is the third region. One burnable poison rod is inserted into each assembly in the first region. This reduces the control rod equivalent and improves the peak factors in the assemblies in the central region. Although there is rather substantial neutron leakage due to the small size of the reactor, because the low-temperature reactor has a low operating temperature and low power density, the reactivity of the xenon poison and Doppler response used to compensate the fuel is rather small, so it is appropriate to use low-enrichment fuel in this reactor. It can be expected that in large heating reactors, using fuel with a concentration similar to that in power reactors will provide a deeper fuel consumption and greatly improve the utilization of the fuel. The nuclear design analyzed cool and hot state reactivity coefficients, Doppler coefficients, and moderator temperature coefficients under controlled and uncontrolled conditions. During the various working conditions throughout the entire lifespan of the reactor, there are always negative temperature reactivity feedback coefficients, so the reactor has excellent self-regulation properties and can use regulation of the second loop to control output power. In the design, we analyzed the number and position of burnable poison rods, control rod equivalents, and various inhomogeneous factors. The results showed that the heat pipes account for just 0.6 percent (their heat pipe factor is 0.49) whereas the heat pipe factors for more than 95 percent of the rods is below 0.4 percent. Structurally, although this reduces the water gap of the control rods, it also is a step toward reducing the heat pipe factors. Table 1 lists the main design parameters.

Table 1. Nuclear Parameters of 5MW THR Fuel Assemblies

Outer diameter of fuel rods, mm	10.0
Fuel core block outer diameter, mm	8.43
²³⁵ U concentration, percent	3
Cladding thickness, mm	0.7
Fuel core gap, mm	13.3
Water/fuel	2.44
Weight of fuel, kg	37.8

Table 1. Nuclear Parameters of 5MW THR Fuel Assemblies (Continued)

k_{∞} , cold state, uncontrolled	1.1132
k_{∞} , cold state, controlled	0.9505
Maximum local peak factor	1.45
Gd ₂ O ₃ weight percentage content	0.5
Number of burnable poison rods	1
Maximum neutron flux n/(cm ² .s)	
5.22 X 10 ¹³	
Average fuel consumption MW.d/t(U)	4,930

III. Thermohydrodynamic Design

The goal of the thermohydrodynamic design was to ensure the integrity of the fuel rod cladding during normal reactor operation and abnormal transient states and not cause significant destruction of the cladding or the leakage of fission products. Based on the axial and radial inhomogeneous factors in the nuclear design and the peak factors within the assemblies, and in consideration with the effects of various indeterminable factors during the process of manufacturing the assemblies—engineering heat pipe factors, the main factors considered were the ²³⁵U concentration and density of the fuel, the dimensions of the core blocks and the cladding, the size of the flow channels, and other deviations, the engineering heat pipe factor for the fuel assemblies of the 5MW THR was conservatively chosen at 1.10. During the process of thermodynamic analysis we also retained a 1.3 safety factor. The linear power density of the fuel rods was selected at 28 kW/m under pressurized water working conditions and 23.9 kW/m during pressurized water microboiling.

In integration with the low temperature, low pressure, and natural circulation characteristic of the 5MW THR we analyzed and compared computed results using the Hensch-Lovy, W-3, B&W-2, and Barnett formulas. We discovered that the computed results using the Barnett formula fit rather well with the experimental results under low pressure working conditions. Under pressurized water working conditions, the MDNBR (minimum deviation nuclear boiling ratio) calculated with Barnett was 2.37 whereas the MDNBR was calculated at 4.26 with W-3 and 30.44 with B&W-2.

The maximum temperature in the center of the fuel rods at rated power was less than 1,100° C. This value is far below the limit stipulated in the design criteria. The calculations showed that the LGHR (linear power density) at melting on the center line of the fuel was more than 3 times the design value. This is much more reliable than the fuel rod properties in regular power reactors. Similar, the fuel specific enthalpy of the fuel rods was just 159 J/g., whereas the limit for regular power reactors under a steady state is 712 J/g. As for the deformation limit which was said to be 1 percent, this was far from attained in the fuel rods of the 5MW THR.

The thermohydrodynamic design also carefully analyzed the accident sequence of the heating reactor and the effects this creates on the fuel rods. These accidents included: 1) Increased heat discharge on the main loop system; 2) Reduced heat discharge on the main loop system; 3) Anomalies in reactivity and power distribution; 4) Increased reactor coolant; 5) Reduced total reactor coolant; 6) Accidents involving an inability to achieve an emergency reactor shutdown.

Based on the data provided from the thermodynamic analysis and using FRAP-T6 to analyze the properties of the fuel rods, several of the more representative accidents and the results they create are listed in Table 2.

Table 2. Several Typical Accidents and Their Effects on Fuel Rod Properties

	1	2	3	4	5
Category of accident	Increased heat discharge in primary loop	Reactivity anomaly	Increased total coolant	Reduced total coolant	Inability to achieve emergency reactor shutdown
Cause of accident	Erroneous operation of reserve pumps	One control rod lifted 2 steps	Pipe rupture in heat exchanger	Rupture of boron injection pipe	ATWS
Relative power ratio	1.17	1.605	1.13	1.035	1.525
Minimum burnup ratio	1.81	1.99	1.98	1.8	2.42
Fuel specific enthalpy, J/g	172.9	162.1	163.3	158.7	174.2
Fuel rod central temperature, °C	1,385	1,198	1,226	1,170	1,234

As Table 2 shows, the fuel rods and their assemblies in the 5MW THR are safe and reliable under accident conditions.

Conclusion

The fuel assemblies of the 5MW THR have gone through design and processing and are now formally inserted into

the reactor for operation. Now, although there is a very large margin in the design and it is rather safe and reliable, ways to take better advantage of the properties of the fuel and its materials will be one of the problems that must be solved in the design of fuel assemblies for large heating reactors.

For this reason, the authors wish to thank those comrades who contributed to the design, development, processing, manufacture, and related work for the fuel assemblies.

Pressure Vessel and Containment for the 5MW THR
916B0017G Chengdu HE DONGLI GONGCHENG
[NUCLEAR POWER ENGINEERING] in Chinese
Vol 11, No 5, 10 Oct 90 pp 93-96

[Article by He Shuyan [0149 2885 1693], Xiong Dunshi [3574 2415 1102], and Liu Junjie [0491 0193 2638] of the Qinghua University Nuclear Energy Technology Institute, Beijing: "5 MW THR Pressure Vessel and Containment Vessel"; manuscript received 23 Apr 90]

[Text]

Abstract: The designs for the 5MW THR pressure vessel and containment vessel took into consideration the relevant Chinese design regulations for pressure vessels and ASME regulations. This article introduces the overall configuration program for the pressure vessel and containment vessel, the principles for determination of the structural shape, and the structural characteristics of the vessels, and provides an overview of work on their design, calculation, and stress analysis, strength assessments, and other areas.

Key words: 5MW experimental low-temperature nuclear heating reactor, pressure vessel, containment vessel, load, stress analysis.

The main loop system for the 5MW THR employs a natural circulation and integrated configuration program. The main heat exchanger is installed inside the pressure vessel and it has no main pumps or main pipelines. This provides the conditions for using a small volume containment vessel and using the smallest possible space between the containment vessel and pressure vessel. The small containment vessel can reduce construction costs and help prevent core loss of coolant water accidents. When a rupture accident at the primary loop pressure margin inside the containment vessel occurs, the primary loop water enters the containment vessel through the pressure vessel and causes a rapid rise in the pressure and temperature within the containment vessel. It also gradually attains equilibrium in the pressure inside the pressure vessel and thus limits the amount of water that flows out of the pressure vessel. The results of accident analysis show that because a small volume containment vessel is used, when a rupture accident occurs in the main loop, the water level in the pressure vessel is at least 0.5 m higher than the active region in the reactor.

I. Brief Description of Structure

A. Reactor pressure vessel

The reactor pressure vessel is one of the key pieces of equipment in the 5 MW THR. It contains the pressure

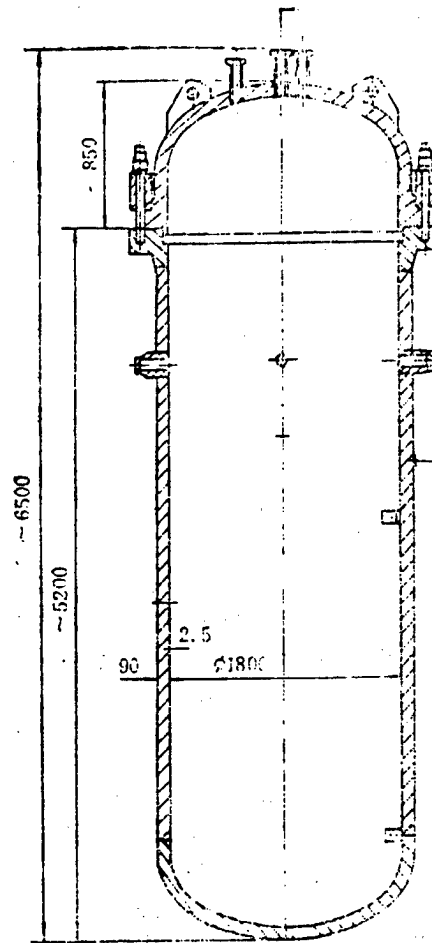

Figure 1. Diagram of Reactor Pressure Vessel

margin between the reactor core and the primary loop coolant. The main parameters of the pressure vessel are: working pressure 1.47 MPa, working temperature 198° C, design pressure 2.45 MPa, design temperature 215° C, inner height of vessel 6,500 mm, and inner diameter of vessel 1,800 mm. Its structure is illustrated in Figure 1.

The pressure vessel is mainly composed of two parts, a cylinder and a removable top, and 44 main bolts are used to connect them into one integrated unit. Two metallic O-rings are used as seals between them. There is a stainless steel built up welding layer 5 to 6 mm thick on the entire inner surface where the pressure vessel and primary loop coolant come into contact.

The pressure vessel's cylinder is composed of a circular cylinder, elliptical lower seal, and cylinder flange welded together.

Although the dual metallic O-ring seal structure used as the primary flange for the pressure vessel is similar in shape to the main seals in international reactor pressure vessels, this was the first time that a metallic O-ring seal

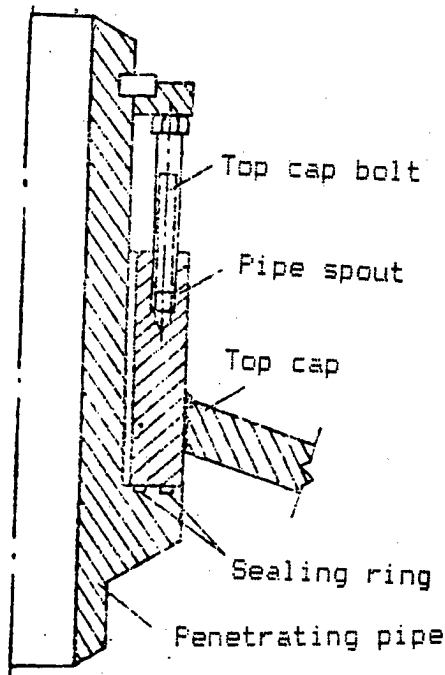

Figure 2. Pressure Vessel Top Cap Pipe Penetration Seal Structure

with a diameter in excess of 2 meters was used in China. The metallic O-ring was designed and manufactured in China. The processing precision, smoothness, and various other properties of the O-ring satisfied design requirements. Finite element stress and deformation analysis were used in the computations to estimate the pretightening of the main bolts, which reliably ensured the seal.

The top cap of the pressure vessel is composed of a seal, flange, and 23 pipe spouts welded together. Because 23 pipe spouts had to be welded to the elliptical top cap which had an inner diameter of 1,800 mm, there was extremely inadequate space. Moreover, the pipelines from much of the equipment and testing sensors inside the pressure vessel passed out of the pipe spouts and were connected with equipment and instruments on the outside of the pressure vessel. Sealed connections had to be guaranteed for the pipelines and pipe spouts that stuck out, and they had to be easy to install and remove. We designed a special pipe penetration seal structure for this purpose. Because they come into contact with the primary loop coolant, dual O-rings were also used for the pipe penetration seals. Their structure is illustrated in Figure 2. They have unique self-tightening characteristics which can reduce the area of the pipe holes. This type of pipe penetration sealing structure was a new design in both China and foreign countries. Debugging and operating practice in the 5MW THR showed that this type of pipe penetration sealing structure was reliable.

B. Containment vessel

The containment vessel is a cylindrical casing. Its structure is illustrated in Figure 3. When a rupture accident occurs in the main loop, the maximum pressure in the containment vessel is 0.95 MPa. The design pressure of the containment vessel is 1.5 MPa. One set of flanges on its full dimension top cap is a unitary forged high-necked flange which a cross-section of 160 mm wide and 180 mm high. Ethylene-propylene rubber ring seals are used between the top and bottom flanges. The upper part of the containment vessel cylinder is a pipe penetration region on which there are 23 connecting pipes installed. For penetrating pipes which have a rather high temperature for the fluids in the pipes, to prevent the occurrence of major heat stress, "hot sleeve" connecting pipes are used. When the diameter of the penetration pipes is greater than 57 mm, stainless steel corrugated pipes are used as connectors between the connecting pipes and penetration pipes to reduce the mechanical stress and heat stress at the connecting pipes.

The material used to make the cylinder walls, seals, and connecting pipes in the containment vessel is 16MnR steel plate or steel pipe. The main flanges are 18MnMoNb. The walls of the cylinder are 20 mm thick and the walls of the cylinder at support and pipe connecting locations is 40 mm thick. The upper and lower seals are standard elliptical seals with a wall thickness of 25 mm. The material is moderate and low-pressure container material that is in common use in China and it has excellent mechanical properties and processing properties.

Because the fast neutron integral flux received by the containment vessel during the lifespan of the reactor is only $1 \times 10^{15} \text{ n/cm}^2$, there was no need to consider non-ductile transition temperature increases caused by irradiation.

II. Stress Analysis and Strength Assessment

The designs for the pressure vessel and containment vessel took into consideration the relevant stipulations in the China's "Design Stipulations for Steel Petrochemical Industry Pressure Vessels" and the United State's ASME regulations and carried out thermoelastic stress calculations, deformation and strength analysis, fatigue resistance lifespan analysis, and non-ductile fracture ductility analysis according to the design requirements of ASME regulations concerning analysis methods.

According to stipulations in the ASME regulations, the load can include the design load, the load under various types of utilization conditions, and the load under experimental conditions. For different utilization conditions, strength and lifespan analysis for the vessel was carried account according to grades A, B, C, and D utilization limits.

The load of the pressure vessel includes the combined load of internal pressure load, temperature stress, gravity load, pipeline back-pressure, main bolt and seal load, earthquake load, and the load caused by changing working conditions. The load of the containment vessel includes combined load of the internal pressure load caused by large amounts of main loop medium leaking into the containment vessel, temperature stress, gravity load, pipeline back-pressure, main bolt load, earthquake load, and the load under different working conditions.

When computing the earthquake load, the reactor structure and the main screening structure of the pressure vessel and containment vessel were simplified into a one-dimensional boom model. In it, the spring coefficients in supporting positions in the pressure vessel and containment vessel were derived from the relationship between load and displacement obtained from the finite element static elastic stress computations. The SAP-5 program was used to make the earthquake resistance computations. The earthquake input used EL CENTRO seismic waves and site artificial synthetic seismic waves

to carry out the computations using the numerical integration method. These two methods were used to derive and compare the horizontal force and vertical force at supporting positions on the pressure vessel and containment vessel. The largest of them were chosen as the earthquake load of the pressure vessel and containment vessel. The earthquake resistance method stipulated for use with experimental reactors in IAEA-TE CDOC-348 was used for the calibration computations. The derive earthquake load was smaller than the results of the methods above.

The static thermoelastic stress computations were done using the LFE three-dimensional elastic equivalent parameter element static computation program compiled by the Qinghua University Nuclear Energy Technology Institute and approved for use in safety inspection procedures by the Nuclear Safety Bureau and the SAP-5 program in common use internationally.

In the load computations, on the basis of thermoelastic stress calculations and stress analysis and based on ASME stipulations, we carried out stress assessments of the containment vessel and pressure vessel for design working conditions, various operating conditions, and experimental working conditions on the basis of the various stress limits stipulated for limited use at A, B, C, and D grades, respectively. The results showed that the combined primary stress, secondary stress, peak stress, and various required stresses at all locations on them met ASME requirements. The computed deformation at all positions on the vessels was extremely small and would have absolutely no effects on the utilization properties of the vessels themselves or on normal operation of the reactor systems. For regions with rather high neutron flux in the pressure vessel, we carried out fracture analysis according to ASME requirements. The results showed that there was a rather large margin of fracture ductility for the materials during the service lifespan of the reactor. We also carried out fatigue-resistance lifespan calibrations of the pressure vessel and containment vessel connecting pipe structures, main bolts, and support structures and calibrated the loss of destabilization resistance of each of the components. After these computations and analysis, it can be felt that the pressure vessel and containment vessel satisfy design and utilization requirements in resistance to plastic destruction and destabilization, resistance to fracturing and brittle destruction, resistance to deformation failure, and fatigue resistance lifespan all satisfied design and utilization requirements and met the related ASME stipulations.

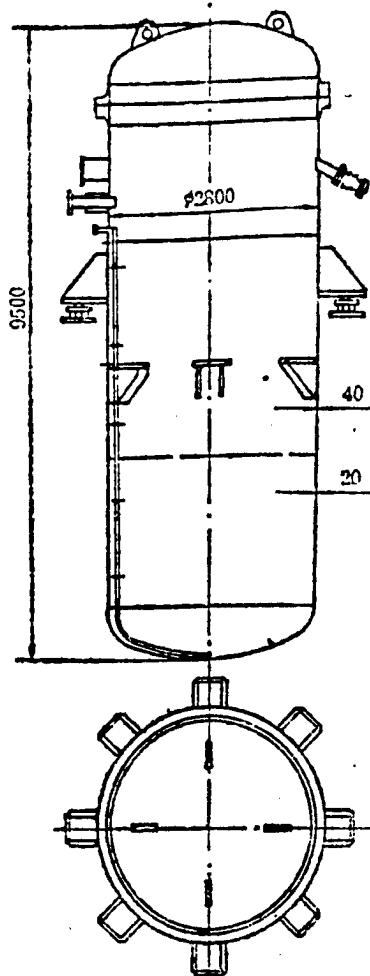

Figure 3. Containment Vessel Structure

III. Conclusion

During the water pressure tests of the pressure vessel and containment vessel, made careful stress and strain measurements which conformed quite well with the results of finite element computations. Coal state and hot state sealing tests also satisfied stipulated leakage limits. This

shows that their structural design and analysis of computations were rational and believable. The actual indicators for the mechanical properties of the products attained the expected results.

Because the internal pressures in the 5MW THR pressure vessel and containment vessel were rather low and the vessels were relatively small, it was easy to attain mechanical performance requirements. Thus, during the structural design, we did not focus on considerations of structural optimization from the perspective of strength and deformation analysis. Instead, with a prerequisite of guaranteeing their performance requirements, we utilized existing technical equipment conditions in manufacturing plants and tried to reduce construction costs as much as possible. These considerations would be different for the design of large, heavy vessels.

State Planning Commission Gives Go-Ahead on 200MW Heat-Supply Reactor

916B0004A Beijing JINGJI RIBAO in Chinese
19 Sep 90 p 1

[Article by reporter Wang Yadong [3769 0068 2639]: "China To Build 200MW Low-Temperature Nuclear Heat-Supply Reactor"]

[Text] At a press conference held by the State Planning Commission on 18 September 1990, it was decided to use the mature technology from the 5MW low-temperature nuclear heat-supply reactor, a key state S&T achievement during the Seventh 5-Year Plan, to establish the first experimental industrial 200MW low-temperature nuclear heat-supply reactor demonstration facility at Jilin Chemical Industry Company. This has moved development of low-temperature nuclear heat-supply reactors in China into a new stage.

Low-temperature nuclear heat-supply reactors are specialized nuclear-powered devices used for heat supply that have been studied and developed in recent years. They have excellent safety and economic properties. Only a few countries have gained a grasp of this type of high technology. To make better use of nuclear energy, use nuclear energy to replace the burning of coal for heat supply, and alleviate the energy resource, communications, and transportation shortages, under the leadership and support of the State Planning Commission, Ministry of Finance, State Science and Technology Commission, State Education Commission, and various administrative departments, and with Qinghua University's Nuclear Energy Technology Institute as the main force, the relevant S&T forces within China were organized in a major cooperative effort for R&D on low-temperature nuclear heat supplies, and they made significant progress. In 1989, an experimental 5MW low-temperature nuclear heat-supply reactor was completed and placed into operation at Qinghua's Nuclear Energy Institute.

The experts pointed out that low-temperature nuclear heat-supply reactors are an ideal energy source for providing centralized heat supplies in urban areas. They can substitute nuclear energy for coal, increase supplies of energy resources, eliminate pollution problems from noxious gases, soot, slag, and so on, and improve the urban environment. One 200MW low-temperature nuclear heat-supply reactor can conserve 300,000 tons of coal a year and satisfy the central heating needs of 3 million m² of structures (equivalent to 60,000 houses), and it can reduce the transport of coal and slag. Because low-temperature nuclear heat-supply reactors have simpler equipment, lower investments, and shorter construction schedules than nuclear power plants, they can be developed through our own efforts based on China's existing industrial and technical foundation. They are one way to accelerate the development and utilization of nuclear energy.

5MW Heat-Supply Reactor Is Big Success for Qinghua University

916B0004B Beijing RENMIN RIBAO in Chinese
19 Sep 90 p 1

[Article by He Huangbiao [0149 7806 1753] and Ma Xuquan [7456 2700 3123]: "Major S&T Achievement for Qinghua University, 5MW Low-Temperature Nuclear Heat-Supply Reactor Passes Examination and Acceptance, Jilin To Build 200 MW Nuclear Heat-Supply Reactor"]

[Text] Qinghua University's 5MW low-temperature nuclear heat-supply reactor passed technical inspection and acceptance and project examination and acceptance by the State Planning Commission and other related units on 18 September 1990. The relevant experts at the meeting feel that this nuclear heat-supply reactor designed and constructed by the Qinghua University Nuclear Energy Technology Institute is this first inherently safe pressure casing type low-temperature nuclear heat-supply reactor placed into operation in the world. Successful development of the 5MW low-temperature nuclear heat-supply reactor is a major S&T achievement at international levels.

To utilize this major S&T achievement in production as quickly as possible, State Planning Commission officials announced that a 200MW low-temperature nuclear heat-supply reactor will be built at Jilin Chemical Industry Company. This will move the development of low-temperature nuclear heat-supply technologies in China to a new stage.

Low-temperature nuclear heat-supply reactors are special nuclear-powered devices used for heat supply that have been studied and developed in recent years. One 200MW nuclear heat-supply reactor can conserve 300,000 tons of coal a year and eliminate noxious gases, soot, slag, and other environmental problems. At present, several countries on the international scene are

doing research on low-temperature nuclear heat-supply reactors, but most are in the design or laboratory stage.

At the press conference on 18 September 1990, the relevant officials pointed out that because low-temperature nuclear heat-supplies have excellent economic benefits, social benefits, and environmental benefits, nuclear heat-supply reactors are a large-scale safe, clean, and economical heat source. It can be expected that after the completion of a large-scale experimental

industrial low-temperature heat-supply reactor demonstration project, they will make a major contribution to substituting nuclear energy for coal, reducing transportation pressures, improving the urban environment, and other areas. Moreover, they will have broad development prospects for providing low-pressure industrial steam to industrial and mining enterprises and using low-temperature nuclear energy to generate power, for low-temperature nuclear cooling, seawater desalination, irradiation processing, and other areas.

This is a U.S. Government publication. Its contents in no way represent the policies, views, or attitudes of the U.S. Government. Users of this publication may cite FBIS or JPRS provided they do so in a manner clearly identifying them as the secondary source.

Foreign Broadcast Information Service (FBIS) and Joint Publications Research Service (JPRS) publications contain political, military, economic, environmental, and sociological news, commentary, and other information, as well as scientific and technical data and reports. All information has been obtained from foreign radio and television broadcasts, news agency transmissions, newspapers, books, and periodicals. Items generally are processed from the first or best available sources. It should not be inferred that they have been disseminated only in the medium, in the language, or to the area indicated. Items from foreign language sources are translated; those from English-language sources are transcribed. Except for excluding certain diacritics, FBIS renders personal names and place-names in accordance with the romanization systems approved for U.S. Government publications by the U.S. Board of Geographic Names.

Headlines, editorial reports, and material enclosed in brackets [] are supplied by FBIS/JPRS. Processing indicators such as [Text] or [Excerpts] in the first line of each item indicate how the information was processed from the original. Unfamiliar names rendered phonetically are enclosed in parentheses. Words or names preceded by a question mark and enclosed in parentheses were not clear from the original source but have been supplied as appropriate to the context. Other unattributed parenthetical notes within the body of an item originate with the source. Times within items are as given by the source. Passages in boldface or italics are as published.

SUBSCRIPTION/PROCUREMENT INFORMATION

The FBIS DAILY REPORT contains current news and information and is published Monday through Friday in eight volumes: China, East Europe, Soviet Union, East Asia, Near East & South Asia, Sub-Saharan Africa, Latin America, and West Europe. Supplements to the DAILY REPORTs may also be available periodically and will be distributed to regular DAILY REPORT subscribers. JPRS publications, which include approximately 50 regional, worldwide, and topical reports, generally contain less time-sensitive information and are published periodically.

Current DAILY REPORTs and JPRS publications are listed in *Government Reports Announcements* issued semimonthly by the National Technical Information Service (NTIS), 5285 Port Royal Road, Springfield, Virginia 22161 and the *Monthly Catalog of U.S. Government Publications* issued by the Superintendent of Documents, U.S. Government Printing Office, Washington, D.C. 20402.

The public may subscribe to either hardcover or microfiche versions of the DAILY REPORTs and JPRS publications through NTIS at the above address or by calling (703) 487-4630. Subscription rates will be

provided by NTIS upon request. Subscriptions are available outside the United States from NTIS or appointed foreign dealers. New subscribers should expect a 30-day delay in receipt of the first issue.

U.S. Government offices may obtain subscriptions to the DAILY REPORTs or JPRS publications (hardcover or microfiche) at no charge through their sponsoring organizations. For additional information or assistance, call FBIS, (202) 338-6735, or write to P.O. Box 2604, Washington, D.C. 20013. Department of Defense consumers are required to submit requests through appropriate command validation channels to DIA, RTS-2C, Washington, D.C. 20301. (Telephone: (202) 373-3771, Autovon: 243-3771.)

Back issues or single copies of the DAILY REPORTs and JPRS publications are not available. Both the DAILY REPORTs and the JPRS publications are on file for public reference at the Library of Congress and at many Federal Depository Libraries. Reference copies may also be seen at many public and university libraries throughout the United States.