

REPORT DOCUMENTATION PAGE

Please read the instructions for the collection of information. Send comments regarding this burden estimate or any other aspect of this collection of information, including the gathering and maintaining the data needed, and completing and reviewing the collection of information, Send comments to Washington Headquarters Services, Directorate for Information Operations and Reports, 1215 Jefferson Davis Highway, Suite 1204, Arlington, VA 22202-4302, and to the Office of Management and Budget, Paperwork Reduction Project (0704-0188), Washington, DC 20503.

1. AGENCY USE ONLY (Leave blank)	2. REPORT DATE 10, 22, 97	3. REPORT TYPE AND DATES COVERED FINAL REPORT 4.96 - 4.97
4. TITLE AND SUBTITLE ROBUSTNESS ANALYSIS AND SYNTHESIS FOR ESSENTIALLY NONLINEAR SYSTEMS		5. FUNDING NUMBERS F49620-96-1-0123
6. AUTHOR(S) ALEXANDRE MEGRETSKI		
7. PERFORMING ORGANIZATION NAME(S) AND ADDRESS(ES) IOWA STATE UNIVERSITY, AMES, IA 50011		8. PERFORMING ORGANIZATION REPORT NUMBER
9. SPONSORING / MONITORING AGENCY NAME(S) AND ADDRESS(ES) AFOSR DR. MARC JACOBS		10. SPONSORING / MONITORING AGENCY REPORT NUMBER

11. SUPPLEMENTARY NOTES

12a. DISTRIBUTION / AVAILABILITY STATEMENT

Approved for public release,  
distribution unlimited

19980116 041

13. ABSTRACT (Maximum 200 words)

The research was concentrated on developing an advanced theory of stability and performance analysis of nonlinear dynamical systems. The ultimate goal is to provide algorithms and software for analytical validation of flight control algorithms involving gain scheduling, actuator saturation, logical switching, etc., thus reducing the current dependence on extensive simulations in feedback control design. A number of new results were obtained. A study of dynamic behaviour of rate limiters allowed for the first time to develop methods of absolute stability analysis that are capable of discriminating between systems with quasiconcave nonlinearities (such as the saturation) and quasiconvex nonlinearities (such as the deadzone). A software package for rigorous analysis of stability and performance of nonlinear/time-varying/uncertain systems was developed, based on the concept of Integral Quadratic Constraints. A new method of gain scheduling for linear feedback design under the condition of control saturation has been developed, with guaranteed stability margins rigorously proven. A unique technique for rigorous analysis of global and semiglobal stability of self-oscillations in higher order relay feedback systems has been developed.

14. SUBJECT TERMS algorithms, nonlinear		15. NUMBER OF PAGES 9	
17. SECURITY CLASSIFICATION OF REPORT UNCLASSIFIED		16. PRICE CODE	
18. SECURITY CLASSIFICATION OF THIS PAGE UNCLASSIFIED	19. SECURITY CLASSIFICATION OF ABSTRACT UNCLASSIFIED	20. LIMITATION OF ABSTRACT UL	

# Robustness Analysis and Synthesis for Essentially Nonlinear Systems Final Report

A. Megretski

Department of Electrical and Computer Engineering

Iowa State University

Ames, IA 50011\*

October 20, 1997

## Abstract

In this report, we will summarize the results obtained under grant F49620-96-1-0123.

---

\*Alexandre Megretski is now with the Department of Electrical Engineering and Computer Science, MIT, Cambridge, MA 02139

# Contents

<b>1</b>	<b>General Information</b>	<b>3</b>
1.1	Status of Effort . . . . .	3
1.2	Personnel Supported . . . . .	3
1.3	Publications (submitted/accepted/published) . . . . .	3
1.4	Interactions/Transitions . . . . .	4
<b>2</b>	<b>Research Accomplishments: Technical Details</b>	<b>4</b>
2.1	Integral Quadratic Constraints based on lower order system analysis. . . . .	4
2.2	Special IQC for semiconcave nonlinearities . . . . .	6

# 1 General Information

## 1.1 Status of Effort

The research program was originally planned for a three-year period. However, because of the new appointment of the principal investigator at MIT, the program was divided into two stages. The first stage, carried out completely at the Iowa State University, produced the following major results.

- A study of dynamic behaviour of rate limiters allowed for the first time to develop methods of absolute stability analysis that are capable of discriminating between systems with quasiconcave nonlinearities (such as the saturation) and quasiconvex nonlinearities (such as the deadzone).
- A software package for rigorous analysis of stability and performance of nonlinear/time-varying/uncertain systems was developed, based on the concept of Integral Quadratic Constraints.
- A new method of gain scheduling for linear feedback design under the condition of control saturation has been developed, with guaranteed stability margins rigorously proven.
- A unique technique for rigorous analysis of global and semiglobal stability of self-oscillations in higher order relay feedback systems has been developed.

## 1.2 Personnel Supported

Assistant Professor A. Megretski, Graduate Students A. Cygankov and C. Gunadi

## 1.3 Publications (submitted/accepted/published)

1. F. Blanchini, A. Megretski, *Robust State Feedback Control of LTV Systems: Nonlinear Is Better Than Linear*. Submitted to IEEE Transactions on Automatic Control.
2. T. Georgiou, M. Khammash, and A. Megretski, *On a Large-Gain Theorem*. Submitted to Systems and Control Letters.
3. A. Megretski, A. Rantzer, *System Analysis via Integral Quadratic Constraints*. Published in IEEE Transactions on Automatic Control.

4. A. Megretski, *Integral Quadratic Constraints in the Design of Gain Scheduled Robust Controllers*, Published in the Proceedings of CDC96.
5. A. Megretski, A. Rantzer, *Integral Quadratic Constraints, Part I/Part II*. Submitted to Systems and Control Letters.
6. A. Megretski, *Global stability of oscillations induced by a relay feedback*. Proceedings of the 1996 IFAC World Congress.
7. A. Megretski, *L2 BIBO output feedback stabilization with saturated control*. Proceedings of the 1996 IFAC World Congress.

## **1.4 Interactions/Transitions**

The results of the supported research have been communicated in presentations at the 1996 Control and Decision Conference, the 1996 IFAC World Congress, 1996 MTNS Conference, and the 1997 European Control Conference. The developed IQC software has been provided for evaluation at the Wright-Patterson AFB, and at Boeing Inc., for the purpose of using it in the analysis of gain scheduled flight control systems.

## **2 Research Accomplishments: Technical Details**

### **2.1 Integral Quadratic Constraints based on lower order system analysis.**

Integral Quadratic Constraints (IQC) are used to describe frequency-domain input-output relations in common nonlinear and time-varying blocks. Essentially, in the IQC-based analysis, deterministic relations in nonlinear blocks are replaced by less detailed uncertain models possessing a special structure which allows easy analysis via convex optimization. The quality of such analysis depends on how close is the match between the uncertain IQC model and the original nonlinear system model. While in the past a number of IQC models has been derived for some basic classes of nonlinear and time-varying blocks, the desired quality of approximation has not been achieved yet for several important cases.

In particular, the classical positivity/passivity methods did not provide an IQC model for the saturation nonlinearity, which would distinguish between deadzone and saturation. As a result, stability analysis of systems with pure integrators controlled via a saturated feedback was essentially not possible using the classical positivity/absolute stability framework.

Similarly, the analysis of gain scheduled control algorithms via constant  $D - G$  scaling is so conservative that it does not allow to account for any *positive* effects of nonlinear gain scheduling.

A promising approach to derivation of advanced IQC models is described below. The approach was applied to obtain less conservative stability conditions for the systems with pure integrators controlled via saturated feedback, systems with backlash hysteresis, nonlinear gain scheduled systems, relay/dry friction systems, etc.

Let  $\Delta_0$  be a nonlinear block (in many cases,  $\Delta_0$  is a memoryless nonlinearity, such as relay, controlled gain, saturation, etc., or a nonlinearity with “discrete” memory, such as the hysteresis nonlinearities). We consider an imaginary experiment: testing  $\Delta_0$  in a feedback loop with a low order (one or two states) linear time invariant system  $G_0$  (see Figure 1). The “results of the experiment” are written in the form of IQC describing the input-output

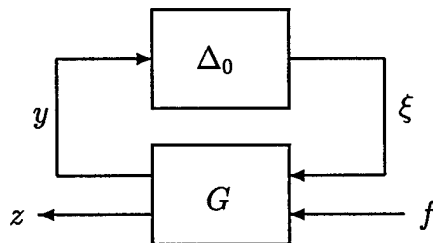

Figure 1: Testing  $\Delta_0$  in a low-order feedback

relation between  $f$  and  $z$ . These IQC can be obtained in two ways:

- re-writing the known IQC describing the relation between  $y$  and  $\xi$  as IQC's describing the relation between  $f$  and  $z$ ;
- applying advanced system analysis tools (non-quadratic Lyapunov functions, optimal control etc.) in the analysis of the closed-loop system in Figure 1).

Now, when the problem of analysis of a feedback interconnection of  $\Delta_0$  with other nonlinear systems is considered, the interconnection is being re-arranged in order to include explicitly the dynamic block on Figure 1 (see Figure 2). There are two sorts of benefits from the proposed approach. First, new important IQC's, not known before, can be obtained. In particular, an exact calculation of the worst case  $L^2$  gain  $f \rightarrow z$  in the feedback interconnection of a saturation and a pure integrator

$$\dot{y} = \text{sat}(f - y), \quad z = y + \text{sat}(f - y),$$

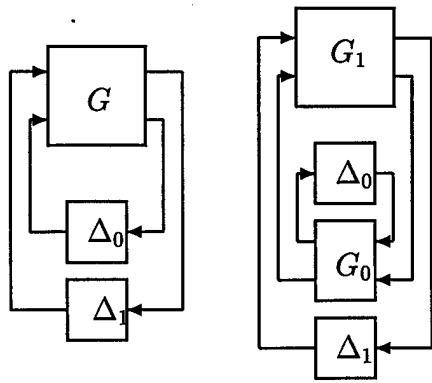

Figure 2: Using the IQC for  $G_0/\Delta_0$  interconnection

results in the gain value  $\gamma = \sqrt{2}$ , which yields perhaps the first IQC capable of distinguishing between the saturation nonlinearity and the deadzone. This IQC can be used in testing stability of systems which are not exponentially stable using the standard  $L^2$  gain analysis. Similar results are being developed for the feedback interconnection of a double pure integrator with a saturated feedback, for the multiplication nonlinearity (important in the analysis of gain scheduling), etc.

The second benefit of the low-order nonlinearity testing is that it makes possible stability analysis of systems with bad-behaving nonlinearities, with applications to the nonlinearities such as the ideal relay, dry friction, and hysteresis.

## 2.2 Special IQC for semiconcave nonlinearities

The main technical issue in this subsection is validation of a set of IQC relating signals  $z$  and  $x$  in the system

$$x(t) = \int_0^t \phi(z(r))dr, \quad (1)$$

where  $\phi$  is a “saturation-like” memoryless nonlinearity. Though system (1), because of its instability, does not fit well within the standard IQC analysis framework, the results originally derived for (1) can be easily transformed into a set of IQC for an “encapsulated” rate limiter system, defined by

$$\dot{x}(t) = \phi(v(t) - x(t)), \quad w(t) = x(t) + \phi(v(t) - x(t)), \quad x(0) = 0 \quad (2)$$

(see Figure 3). For example, it will follow from the main result that the gain “from  $v$  to  $w$ ” in system (2) does not exceed  $\sqrt{2}$ .

Note that while the gain is exactly  $\sqrt{2}$  for  $\phi(y) = \text{sat}(y)$ , replacing  $\phi(y) = \text{sat}(y)$  by its linearization at zero,  $\phi(y) = y$ , yields an identity system  $w = v$  (the induced  $L_2$  gain equals 1), while replacing  $\phi(y) = \text{sat}(y)$  by  $\phi(y) = \text{dzn}(y)$  results in an infinite  $L_2$  gain.

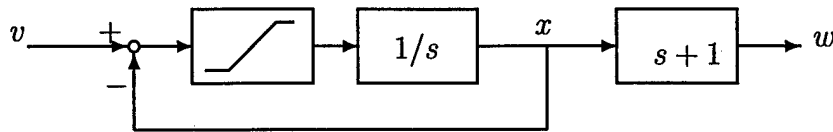

Figure 3: Encapsulation of a rate limiter

The IQC result has broad applications in the analysis of more complex systems (higher order, other nonlinearities, time-variance, uncertainty) that include the feedback interconnection (2) as a subsystem. Generally, the results of this paper can be applied to any system of the form

$$\begin{bmatrix} v_1 \\ v_2 \end{bmatrix} = G_0 \begin{bmatrix} \Delta_1 v_1 \\ \phi(v_2) \end{bmatrix}, \quad G_0 = \begin{bmatrix} G_{11} & (s+1)(G_{12}-1)/s \\ G_{21} & (s+1)G_{22}/s \end{bmatrix}, \quad (3)$$

where  $\phi$  is the same as in (2),  $\Delta_1$  represents other nonlinearities/uncertainties in the system, and  $G_{ij}$  are stable proper transfer matrices. While system (3) is not given in the standard IQC analysis format, it can be reduced, via a simple feedback loop transformation, to a standard feedback interconnection of a stable LTI plant with a structured ‘‘uncertainty’’ which consists of blocks  $\Delta$  and (2)

$$\begin{bmatrix} \bar{v}_1 \\ \bar{v}_2 \end{bmatrix} = G \begin{bmatrix} \Delta_1 \bar{v}_1 \\ \Delta_\phi(\bar{v}_2) \end{bmatrix}, \quad G = \begin{bmatrix} G_{11} & G_{12} \\ G_{21} & G_{22} \end{bmatrix}, \quad (4)$$

where  $\Delta_\phi$  is the operator  $v \rightarrow w$  defined by (2) (see Figure 4).

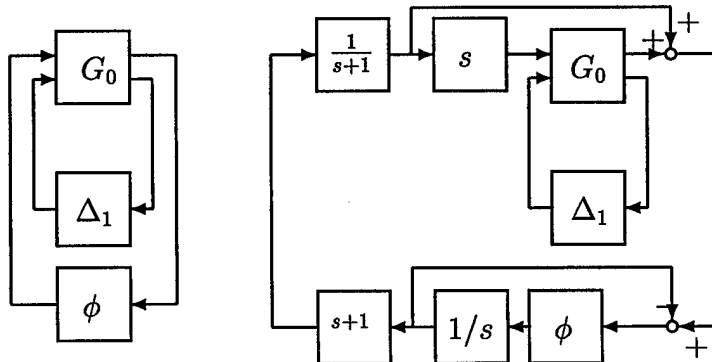

Figure 4: Loop transformation for encapsulation

The results of this section hold for a large class of *semiconcave* functions  $\phi$ . The definition of a semiconcave function summarizes those features of the ideal saturation nonlinearity which are essential in proving the  $\sqrt{2}$ -gain result and its generalizations.

**Definition** A monotonically non-decreasing odd function  $\phi : \mathbf{R} \rightarrow \mathbf{R}$  is called *semiconcave* if  $\phi(z) = \phi(z)/z$  is monotonically non-increasing over the interval  $z \in (0, \infty)$ . The set of all semiconcave functions will be denoted by  $\mathcal{SC}$ .

It is easy to see that a semiconcave function  $\phi = \phi(z)$  is differentiable at  $z = 0$  iff  $\phi(z)/z$  is bounded on the interval  $(0, \infty)$ , in which case

$$\dot{\phi}(0) = \sup_{z>0} \frac{\phi(z)}{z}. \quad (5)$$

For convenience, we will consider (5) as a definition of  $\dot{\phi}(0)$  in the case when the right side in (5) is infinity. Note also that  $\phi(0) = 0$  would imply  $\phi \equiv 0$ , in which case system (1) is trivial.

**Theorem 2.1** *Let  $\phi$  be a semiconcave function with  $\dot{\phi}(0) = K$ ,  $0 < K < \infty$ ,  $b \in \mathbf{R}$ . The inequality*

$$\int_0^\infty \{2|z + bx|^2 - |z|^2 - z\phi(z)/K\} dt \geq 0 \quad (6)$$

*holds for any  $x, z \in L_2$  satisfying relation (1). Moreover, if  $b \geq 0$  then*

$$\int_0^T \{2|z + bx|^2 - |z|^2 - z\phi(z)/K\} dt \geq 0 \quad (7)$$

*for all  $T \geq 0$ .*

Inequality (6) can be considered as a family of IQC describing the relation between  $z$  and  $\phi(z)$ . Since the corresponding  $\sigma_L$  is defined by an unstable system  $L$  (contains a pure integrator), it is difficult to use (6) directly in the analysis of systems involving semiconcave nonlinearities. To resolve this problem, (6) is re-written as a set of IQC describing the "encapsulated" rate limiter (2) (see Figure 3).

**Theorem 2.2** *Let  $\phi$  be a semiconcave function with  $\dot{\phi}(0) = K$ ,  $0 < K < \infty$ ,  $b \in \mathbf{R}$ ,  $a \geq 0$ . Define  $\Delta_\phi^a$  as a system  $v \rightarrow w$ , where*

$$\dot{x} = \phi(v - x), \quad w = ax + \phi(v - x), \quad x(0) = 0. \quad (8)$$

*The system is stable, and the inequality*

$$2\|v + bx\|^2 \geq \|v - x\|^2 + \langle v - x, w - ax \rangle / K \geq 0 \quad (9)$$

*holds for any  $v \in L_2$ .*

**Proof** of Theorem 2.2. For  $b = 1$ ,  $z = v - x$ , inequality (7) implies  $\|P_T(v - x)\| \leq 2\|P_T v\|$ . Hence system  $\Delta_\phi^a$  is stable. In particular,  $x, w \in L_2$  whenever  $v \in L_2$ . Now (6) implies (9) for any  $b \in \mathbf{R}$ . ■

Note that  $x = G_a w$  where  $G_a(s) = 1/(s + a)$ , i.e. (9) are true IQC relating  $v$  and  $w$ . If  $\phi$  is not a semiconcave function, these IQC are generally not valid. For example, Theorem 2.2 with  $K = 1, a = 1, b = -0.5$  implies

$$\|v\|^2 \geq 0.5\|x\|^2 + \langle v - x, \phi(v - x) \rangle \geq 0.5\|x + \phi(v - x)\|^2,$$

where it was used in the derivation that

$$\langle x, \phi(v - x) \rangle = \langle x, \dot{x} \rangle = 0,$$

and

$$\langle v - x, \phi(v - x) \rangle \geq \|\phi(v - x)\|^2.$$

Therefore,  $\|\Delta_\phi^1\| \leq \sqrt{2}$  when  $\phi$  is semiconcave and  $\dot{\phi}(0) \leq 1$ . On the other hand, it is easy to see that replacing  $\phi$  by  $\text{dzn}$  yields an unstable system  $\Delta_\phi^1$  (infinite  $L_2$  gain).

There are other IQC known to describe the relation between  $z$  and  $\phi(z)$ . The criterion by Zames and Falb (SIAM J. of Control, 6(1):89-108, 1968) states that

$$\langle Kz - \phi(z), H_1 z \rangle + \langle H_2(Kz - \phi(z)), z \rangle \geq 0, \quad (10)$$

where  $H_1, H_2$  are LTI systems such that

$$H_i(s) = D_i + C_i(sI - A_i)^{-1}B_i, \quad D_i \geq \int_0^\infty |C_i e^{A_i t} B_i| dt, \quad (11)$$

and  $\dot{\phi} \in [0, K]$ . These IQC can be re-written as input/output relations for  $w = \Delta_\phi^a v$ :

$$\langle K(v - x) - (v - aw), H_1(v - x) \rangle + \langle H_2(K(v - x) - (v - aw)), v - x \rangle \geq 0, \quad (12)$$

where, as before,  $x = G_a w$ .