

REPORT DOCUMENTATION PAGE			Form Approved OMB No. 0704-0188	
<small>Public reporting burden for this collection of information is estimated to average 1 hour per response, including the time for reviewing instructions, searching existing data sources, gathering and maintaining the data needed, and completing and reviewing the collection of information. Send comments regarding this burden estimate or any other aspect of this collection of information, including suggestions for reducing this burden, to Washington Headquarters Service, Directorate for Information Operations and Reports, 1215 Jefferson Davis Highway, Suite 1204, Arlington, VA 22202-4302, and to the Office of Management and Budget, Paperwork Reduction Project (0704-0188), Washington, DC 20503.</small>				
1. AGENCY USE ONLY (Leave blank)	2. REPORT DATE 6/10/96	3. REPORT TYPE AND DATES COVERED Final, 9/29/92 - 9/30/95		
4. TITLE AND SUBTITLE A study of Diamond & Diamond-Like Thin Films with Applications to Large Caliber Electric Guns & Associated Energy Storage Devices (Capacitors and Batteries)			5. FUNDING NUMBERS DAAA21-92-C-0080	
6. AUTHOR(S) Dr. Elvira Williams, P.I.				
7. PERFORMING ORGANIZATION NAME(S) AND ADDRESS(ES) North Carolina Agricultural and Technical State University 1601 East Market Street Suite 305 Dowdy Building Greensboro, North Carolina 27411			8. PERFORMING ORGANIZATION REPORT NUMBER 4-41065	
9. SPONSORING/MONITORING AGENCY NAME(S) AND ADDRESS(ES) Department of Army U.S. Army AMCCOM Picatinny Arsenal, NJ 07806- 5000			10. SPONSORING/MONITORING AGENCY REPORT NUMBER Unknown	
11. SUPPLEMENTARY NOTES N/A			<div style="border: 2px solid black; padding: 10px; font-size: 2em; font-weight: bold;">19980203 051</div>	
12. DISTRIBUTION/AVAILABILITY STATEMENT Unlimited			13. DISTRIBUTION CODE	
13. ABSTRACT (Maximum 200 words) An interdisciplinary research team of A&T Physics and Chemistry faculty and students (graduate and undergraduate) successfully deposited thin diamond-like carbon (DLC) films on substrates provided them by ARDEC, as proposed. The substrates included aluminum, alumina, copper and copper chromium. The films were grown by the Plasma Enhanced Chemical Vapor Deposition (PECVD) method using a deposition system by Technics, Inc. The films were characterized by their indices of refraction (measured using a Gaertner L - 117 ellipsometer) and their Raman Spectra (measured using a spectrometer at the University of North Carolina at Chapel Hill, Chapel Hill, NC). Graduate studies (1 M.S., 1 Ph.D.) dissertations were developed from this study. The M.S. thesis was completed by and A&T Chemistry student by the close of this project. Important dielectric studies were done by the Ph.D. graduate student at the Institute of Advanced Technology at the University of Texas at Austin, Austin, TX.				
14. SUBJECT TERMS diamond thin films, diamond-like carbon (DLC) thin films, dielectric properties/applications			15. NUMBER OF PAGES 92, including Appendices	
			16. PRICE CODE N/A	
17. SECURITY CLASSIFICATION OF REPORT unclassified	18. SECURITY CLASSIFICATION OF THIS PAGE unclassified	19. SECURITY CLASSIFICATION OF ABSTRACT unclassified	20. LIMITATION OF ABSTRACT	

**North Carolina Agricultural and Technical State University
Greensboro, North Carolina**

**"A Study of Diamond and Diamond-Like Thin Films with
Applications to Large Caliber Electric Guns and Associated
Energy Storage Devices (Capacitors and Batteries)"
Contract No. DAAA21-92-C-0080**

**Final Technical Progress Report
(October 1, 1992 - September 30, 1995)**

prepared for

**United States Army
Armament Research Development and Engineering Center
(ARDEC)**

submitted by

**Dr. Elvira S. Williams, Principal Investigator
Dr. Johnnie Richardson, Jr., Co-Investigator
Dr. Alvin Kennedy, Co-Investigator**

October 26, 1995

Approved for public release:
distribution unlimited.

TABLE OF CONTENTS

<u>DESCRIPTION</u>	<u>PAGE</u>
I. Final Technical Accomplishments Summary.....	1
II. Planned Technical Accomplishment Summary.....	14
III. Final Financial Statement.....	16

I. FINAL TECHNICAL ACCOMPLISHMENTS SUMMARY

1. First Quarterly Technical Report (October 1, 1992 - January 26, 1993) Summary - Year 1

During the **first quarter**, the project was staffed with a principal investigator (physicist), two* co-investigators (1 physicist, 1 chemist), a part-time secretary, one graduate student (chemistry) and twelve (12) undergraduate (physics and chemistry) student workers. [Note: Budget revisions made by ARDEC, reflected a \$3,187 cut in secretarial services, but a net \$7,846 increase in overall proposed first cycle funding, which the investigators were authorized by ARDEC to expend as they saw fit. The choice was made to use the net increase for the first funding cycle for student workers]. Also during the first quarter, lab supplies were ordered, new staff was trained and investigators began work on the proposed tasks set forth in Appendix A, which were originally scheduled to begin in May, 1993. Also during this quarter, on January 11, 1993 the principal investigator and both co-investigators met in a collaborative conference with Marilyn Freeman (ARDEC Contracting Officer's Representative and researcher at both the Institute of Advanced Technology (IAT) at the University of Texas at Austin; and at the Electrical Armament Division of ARDEC) at N.C. A&T State University. Together they generated a more realistic task schedule that took into consideration the time the award was actually made which was later than expected. The revised task schedule is Appendix B.

* One co-investigator was placed on staff in October at the beginning of the project. The second was formally added in January, 1993 at the beginning of the second semester, because his department (Chemistry) was unable to find replacement teaching staff for his classes (which began in August) in October.

2. Second Quarterly Technical Report (January 27, 1993 - April 26, 1993)
Summary - Year 1

During the **second quarter**, the N.C. A&T State University research team members concentrated on characterization of the deposition chamber (See Appendices C and D) the x-,y-,z- directions for diamond deposition using silicon substrates as standard, as was proposed. They found that deposition depended on x-,y-,z-. Note: The chemistry members used infrared spectroscopy to characterize the diamond and diamond-like carbon (DLC) films.

The physics team members deposited and characterized the films. As proposed, they deposited the films using the Plasma Enhanced Chemical Vapor Deposition (PECVD) technique in their Plasma Deposition Chamber by Technics, Inc. Also, as proposed, they characterized the films using a Gaertner L-117 ellipsometer to measure their indices of refraction.

3. Third Quarterly Technical Report (April 27, 1993- July 26, 1993)
Summary - Year 1

During the **third quarter**, the N.C. A&T State University research team members continued to focus on characterization of the deposition chamber in the x-,y-,z- directions for diamond deposition using silicon substrates, as standard. Investigations of the variation in -z gave rise to some very interesting fringe and deposition patterns associated with spacer type and with electric field effects which the team began to consider. Also, as proposed, the team deposited a DLC film on an aluminum substrate provided by ARDEC (designated as Experiment # 1, see Appendix E for experimental detail). This deposit was made during a collaborative research visit by Marilyn Freeman to N.C. A&T State University in June of that year. This sample was taken back by Marilyn Freeman to IAT for adhesion studies

and other observations. It was later brought to a Collaborative Conference at ARDEC in June with Kern Strickland and Greg Pappatrefon of ARDEC and the A&T research team. Here it was determined that cleaner film handling procedures prior to deposition were needed. Also at the ARDEC meeting were: Dr. T. Richard Jow, Research Physical Scientist at Fort Monmouth, N.J. and Dr. W.J. Sergeant, James Clerk Maxwell Professor of the State University of New York at Buffalo. Other accomplishments at the ARDEC meeting included reports on: 1) the contract status and recent visit to A&T by Marilyn Freeman, 2) technical accomplishments to date and chamber characterization results by Elvira Williams, 3) IR analysis of DLC films to date by Alvin Kennedy and 4) analytical tools or techniques required for film characterization and desired equipment list by Johnnie Richardson. A discussion/planning session was also held in which it was decided we needed to: 1) design some experiments to fill in the gaps/holes in chamber characterization data, 2) design some experiments to get the most mileage per experiment, 3) design multiple experiments to study a single film characteristic, 4) establish a cleaning procedure, 5) establish mechanical testing procedures 6) use witness plates to determine deposited mass, 7) do reliability measurements and 8) reschedule current tasks to accommodate new and revised tasks. Upon their return to A&T, team members completed #1 above and either continued or began working on #'s 2,3,4, and 5.

4. Fourth Quarterly Technical Progress Report (July 27, 1993 - October 26, 1993) Summary - Year 1

During the **fourth quarter**, focus was on the following:

- (1) continued chamber characterization . (It was determined that the deposition process was affected by all substrate positions, -x , -y and -z).

(2) designing experiments to get the most mileage per experiment,

A collaborative research meeting was held at N.C. A&T State University on September 24-26, 1993. Attendees at the meeting on September 24, 1993 were: The A&T research team (Drs. Alvin Kennedy, Johnnie Richardson and Elvira Williams), Marilyn Freeman and Dr. Persad Chadee from the Institute of Advanced Technology (IAT) at the University of Texas at Austin. Attendees on September 25, 1993 were: Marilyn Freeman, Elvira Williams, Dawn Fant, and Donald Anderson (Chemistry grad students), A. Akpan (lab assistant). Attendees on September 26, 1993 were: Marilyn Freeman, Alvin Kennedy, Elvira Williams, Dawn Fant, Donald Anderson, and A. Akpan. During the technical meeting on September 24, 1993, Dr. Chadee suggested a most-mileage experiment in which substrate type and x-, -y, and -z positions were to be varied in a single run (See Appendix F. p.4 for description of experiment).

(3) establishing a routine substrate cleaning procedure (acetone bath) on all substrates and an etching procedure (using NaOH solution on selected aluminum substrates)

(4) deposition of DLC films on aluminum (to replicate the results of Experiment # 1 - reported on in the third quarterly report- but this time with cleaned substrates). Also, deposition of DLC films on copper and copper/chromium substrates provided by ARDEC was a focus.

The purposes of these experiments (See Appendix F, pp. 5-27 for experimental detail) were to: obtain preliminary temperature profiles using heat tapes, replicate results of Experiments#1 with cleaned substrates, obtain samples of DLC films for further analysis by test methods other than those currently available at NC A&T, coat with DLC film a Cu/Cr coated ARDEC plate, and determine effects of raising Rf power on quality and characteristics of carbon film (DLC) on various

substrates,

A normalized deposition rate (NDR) was defined in connection with variation of deposition rate with Rf power and height (z) inside the chamber. NDR was defined as mass/area* time.

Experimental results suggests: (1) The deposition composition is strongly dependent upon the power, High power levels (120 W) tends to produce more graphite-like carbon structures. (2) The deposition rate is strongly dependent on the power, and increases as the power increases. (3) The deposition rate appears to decrease as the height of the substrate in the chamber increases. (4) The type of substrate and spacer used seems to affect the deposition rate.

(5) Electric Field approximations at film surface for metal and glass spacers. See Appendix F, pp. 28 - 39 for discussion. Preliminary modeling of the electric field between the plates of a parallel plate capacitor (representations of the deposition chamber) suggests:

(1) The localized electric field above a substrate on glass or metal spacers predominates. (2) Inside the chamber plates, vacuum, spacers, substrates, DLC films, all form a series capacitor arrangement. (3) The top capacitor plate is at 440 volts.

(6) thickness measurements of DLC films on silicon wafers/glass substrates. These analyses were made by Marilyn Freeman at sites other than A&T. Such measurements (using a Dektak IIA surface profile measuring system) revealed that our films were from 3500 to 7400 angstroms thick.

**5. First Quarterly Technical Report (October 27, 1993 - January 26, 1994)
Summary - Year 2**

On December 13, 1993, a collaborative research meeting was held at Picatinny Arsenal in the Nuclear Division. Attendees: Alvin Kenny, Johnnie Richardson, Jr. and Elvira Williams, Marilyn Freeman and Greg Pappatrefon. Major shared observations were (1) that deposition results depended on whether spacers were conductors or insulators and (2) it was unclear whether the top or bottom plate of the deposition chamber was at ground (the manual did not specify). The team designed some experiments to shed light on these issues. The experiments were to be carried out at A&T with Marilyn Free participating in the experiments. The experiments were conducted.

Also while at Picatinny, the team toured Greg's lab and had some profilometer measurements done on some of our films and found their thicknesses reasonable. The team also toured the Optics Division at Picatinny to try to get some Raman measurements on the films, but they were too thin to yield usable results by the method used.

While in New Jersey (on December 14, 1993), the team also toured the Electronics section of Dr. Richard Jow's lab at Fort Monmouth. Dr. Jow agreed to make needed capacitor measurements for the team. The team also toured the Diamond Deposition lab at Fort Monmouth.

When the A&T segment of the team arrived back home, they did the grounding test experiment. The grounding experiments consisted of measuring the voltage versus power between the chamber plates which showed an increase of voltage with power. From these experiments, it was determined that the bottom plate was at ground.

A collaborative research meeting was held at A&T December 17-18, 1993

with attendees: Alvin Kennedy, Johnnie Richardson, Jr., Elvira Williams, Marilyn Freeman and Mr. A. Akpan (research assistant). The team carried out the experiment that was designed at the Picatinny meeting to determine the effects of grounding the metal substrates on the quality and characteristics of deposited carbon films (DLC). This experiment was labeled Experiment #4, since it was the 4th experiment that the team did together. The details of this experiment are in Appendix G.

Experimental results suggest: (1) At 30 W, the substrates which were in contact with the baseplate have a higher deposition rate than the substrates on insulating glass spacers. (2) For both types of spacers, the deposition rate decreases as the height increases. (3) At 90 W no uniform film was deposited on the substrates in contact with the baseplates. There appeared to be remains of etched film on the surface of these substrates. The deposition rate for these films were calculated from the debris on the surface. It is possible that a film was formed, but the etch rate exceeded the deposition rate for these conditions. At any rate, these results clearly demonstrate that the electric field near the surface of the substrate strongly influences the DLC formation. (4) The surface of grounded substrates (1 Cu, 1 Al) were etched away, while the surfaces of floating electrodes (1 Cu, 1 Al) were coated with uniform DLC films. The substrates were all in the chamber at the same time and part of the same run. Under these deposition conditions, the Cu and the Al depositions rates were the same, while in previous experiments, the Cu deposition rates were lower than those for Al. The differences could be due to the different local electric fields for the two experiments. (5) For Cu substrates on glass spacers, there appears to be a linear relationship between power and deposition rate.

The complexity of the deposition conditions needed for DLC films required that we begin to consider using experimental design techniques to determine the important deposition factors.

**6. Second Quarterly Technical Report (January 27, 1994 - April 26, 1994)
Summary - Year 2**

Aside from weekly seminars with faculty and students to discuss and plan project events, the following other technical accomplishments were made:

1. Fabrication of 2 working Al-DLC capacitors (Al coatings done at ARDEC, DLC coatings done at A&T). Capacitors gave dielectric data, although they did show signs of leakage, possibly due to pinholes.
2. Made null Raman readings of selected films (made at A&T) at ARDEC. Readings possibly null because the films were too thin.
3. Began to compile a data base of all runs done at A&T to date to look for patterns and other information that could enhance deposition techniques.
4. TEM measurements on DLC samples (DLC deposited at A&T, TEM measurements made at the IAT). Ring and spot patterns suggested crystalline film components. X-ray diffraction patterns suggested amorphous film which could be related to grain size.
5. We studied closely a paper, "Towards a General Concept of Diamond Chemical Vapor Deposition" by Backmon and others, as it relates to our work. A Diamond and non-diamond growth region based on the ratio of atoms of hydrogen (or oxygen) to the total number of reactant gas atoms. For our 22.7 sccm CH₄ to 50 sccm H₂ DLC films, our ratio was calculated to be 0.894 as follows:

$$(90.8 + 100) \text{ sccm} / (22.7 + 190.8) \text{ sccm} = 0.894.$$

We examined the capability of our deposition system as it relates to duplicating the reactant gas ratios discussed in that paper.

6. We compiled a list of Diamond Thin Films journals.

7. We held technical meetings at A&T (March 15-16, 1994) in which experiments #5 and #6 were performed. The objectives of these experiments were to obtain thicker films than those previously deposited on Al-on-glass plates, make capacitor devices from them and to analyze the devices. The experimental procedures are in Appendix H.

7. Third Quarterly Technical Report (April 27, 1994 - July 26, 1994) Summary - Year 2

Aside from the sharing of technical information and updates at the investigators' meetings and staff seminars, very little technical accomplishment in the area of film deposition was made. This was because of a breakdown of the flow controllers on the deposition system and the long subsequent delay in the manufacturer's shipment of the new flow meters and accessories that were ordered.

The new flow meters are calibrated to accommodate a single type reactant gas. This eliminated the need to calibrate the multi-gas flow controllers of the old system each time a new reactant gas is used.

The replacement parts were delivered July 21, 1994 just four days before the close of the current reporting period. This dilemma caused us to have to cut one of our two physics professors from the staff for the month of July. also in May, with the close of the academic year, the number of student workers was cut from 12 to 2 (1 graduate and 1 undergraduate). Graduate student, Dawn Fant (Chemistry), began to clearly define a thesis problem, which was reported on in subsequent quarterly reports.

Because of the flow meter problem, a planned technical meeting between A&T and Marilyn Freeman of IAT/ARDEC originally set for July 11-15, 1994 was cut to July 11-13, 1994. Instead of doing experiments,

investigators at this meeting, shared technical information and planned future events. It was decided in that meeting that a no-cost extension request should be made in order for it to be possible for the team to have time to fulfill original/ revised contractual obligations to ARDEC. The specific planned technical accomplishments that came out of the July technical meeting that will fulfill all original/ revised contractual obligations were reported in the Planned Technical Accomplishments section of the July 26, 1994 Quarterly Report. This section of the report is reproduced here as Appendix I and consisted of a total of 12 more experiments.

**8. Fourth Quarterly Technical Report (July 27, 1994 - October 26, 1994)
Summary - Year 2**

Principal investigators, Elvira Williams and Johnnie Richardson, along with one graduate and one undergraduate student, continued to hold weekly seminars and to work on the project during the summer of this reporting period.

Very little technical advancement was made during this reporting period because the vacuum pump failed. Delays associated with this failure, along with those associated the gas flow controllers (reported on in the previous quarterly report) made it necessary to request a no-cost extension of the project from September 30, 1994 to March 30, 1995. We made the request. It was granted. But, because no additional funds were received, the staff had to be cut. However, all three A&T professors continued to work on the project. The professors were released from their from their normal duties 16% (Richardson), 2% (Williams) and 0% (Kenny). Also, 1 undergraduate and 1 graduate student continued to be paid from ARDEC funds. Four (4) PENS (undergraduate) students also worked on the project, but were paid from non-ARDEC funds.

Mrs. Freeman met at A&T for another in the series of technical meetings on the projects. During this meeting (October 24-25, 1994) successful deposition runs were made on the 12 remaining experiments since the problems with the flow meters and with the vacuum pump had been solved.

Graduate student's (Dawn Fant - Chemistry) thesis work continued, with detailed progress reports made in each quarterly report.

9. First Quarterly Technical Report (October 27, 1994 - January 26, 1995) Summary - Year 3

The principal investigators and students continued to hold weekly seminars and to work on the project. We continued to hold technical meetings between A&T and Marilyn Freeman of IAT/ARDEC during which we worked on the remaining ARDEC experiments. During this reporting period these meetings were held December 11-16, 1994 and January, 14-16, 1995.

Near the end of the last reporting period, the A&T segment of the team began a collaborative research effort with researchers in the Physics (Dr. Laurie McNeil) and Chemistry (Dr. Eugene Irene) departments at the University of North Carolina at Chapel Hill, Chapel Hill, NC. The A&T team began traveling to the University of North Carolina (about 50 miles away) where they spent Monday mornings obtaining Raman spectra of the DLC films produced in their lab at A&T. This work was done in Dr. Laurie McNeil's spectroscopy lab.

To increase productivity (i.e. to reduce down time in the lab) and, therefore, to make the lab more competitive in generating funds for continued operation, the following pieces of equipment were ordered:

1. Rotary Vane Vacuum Pump
2. Helium Neon Laser
3. Power Supply for Laser
4. Mac Performa 475 Computer System & Ethernet Transceiver

The graduate student's (Dawn Fant - Chemistry) thesis work continued, with detailed progress reports made in each quarterly report.

10. Second Quarterly Technical Report (January 27, 1995 - April 26, 1995) Summary - Year 3

The principal investigators and students continued to hold weekly seminars and to work on the project. We also continued our collaborative research efforts with the University of North Carolina at Chapel Hill.

The equipment that was ordered during the last quarterly reporting period was received and installed, as needed. However, delays associated with equipment failures (previously discussed) necessitated a request for another no-cost extension (from March 30, 1995 - June 30, 1995). The request was granted.

Graduate student's (Dawn ATSU Chemistry) thesis work continued, with detailed progress reports made in each quarterly report.

11. Third Quarterly Technical Report (April 27, 1995 - July 26, 1995) Summary - Year 3

The principal investigators and students continued to hold weekly seminars and to work on the project. We also continued our collabo-

rative research efforts with the University of North Carolina at Chapel Hill.

We continued to have technical meetings between A&T and Marilyn Freeman of IAT/ARDEC. During this reporting period, Marilyn Freeman was at A&T May 8-9, 1995. During that time, Marilyn conducted Raman spectroscopy experiments on some DLC samples at the University of North Carolina. Essentially, all necessary ARDEC experiments have been completed at the time of this report.

In addition, to the graduate work related to the ARDEC project that has been taking place at A&T, Marilyn Freeman has been working on work towards a Ph. D. in Mechanical Engineering at the University of Texas at Austin.

In order help with the upgrade of our lab, ARDEC has donated some badly-needed, clean room equipment to A&T (see following page for list) for use in the Plasma Deposition Lab. However, some procurement problems have prohibited us from receiving the equipment as part of the existing contract, which ARDEC agreed to do. However, to allow time for this to happen, we requested and was granted a no-cost extension from June 30, 1995 - September 30, 1995.

**12. Fourth Quarterly Technical Report (July 27, 1995 - October 26, 1995)
Summary - Year 3**

The principal investigators and students continued to work in the lab with concentration mainly on maximum mileage experiments. The graduate student in Chemistry (Dawn Fant) at A&T and Mrs. Freeman (at IAT) continued to work on their thesis problems.

During this reporting period, Ms. Fant completed the requirements for her master's degree in chemistry and enrolled in graduate school to work on her Ph. D. at the University of North Carolina at Chapel this fall. A copy of the abstract of her thesis entitled "Characterization of Diamond-Like Carbon Films Using Two-Level Factorial Experimental Design" , is on the following page. Dawn successfully defended her thesis on August 21, 1995.

Although we have not yet received the equipment donated by ARDEC, we are continuing to make efforts toward that end.

II. PLANNED TECHNICAL ACCOMPLISHMENTS SUMMARY

Working on the ARDEC project has been a richly, rewarding experience for the A&T faculty and students. We greatly appreciate the support that has been given to us. We plan to continue to operate the Plasma Deposition Laboratory, but with greater productivity because of the help that we have received from ARDEC.

We will continue to watch for Broad Agency and other announcements from ARDEC and plan to submit competitive proposals for projects that are of mutual interest to ARDEC and the principal investigators of the A&T Plasma Deposition Laboratory.

DEFENSE
Department of Chemistry
North Carolina Agricultural and Technical State University

**CHARACTERIZATION OF DIAMOND LIKE CARBON FILMS USING TWO LEVEL
FACTORIAL EXPERIMENTAL DESIGN**

By

Dawn Heather Fant

There are many chemical vapor deposition (cvd) techniques that have been used to synthesize diamond and diamond like carbon films. These different cvd techniques have all proven to effectively produce diamond and dlc films. However, some properties such as film quality, growth rates, and thicknesses vary from technique to technique. Very little is known about the actual chemistry involved in the cvd system and as a result there has been an on going quest to optimize the different deposition systems. There has been a tremendous amount of work done to determine the best processing parameters for the synthesis of these films for many years.

This research focused on using the first level of a two level factorial design to characterize a radio frequency plasma enhanced chemical vapor deposition system. Experimental Design is a statistical mathematical model that is most often used in chemical and engineering plants to optimize chemical and manufacturing processes. This model reduces the amount of experiments needed to gather a sufficient amount of information, determines important experimental factors and the effects that varying factors simultaneously has on the system. Substrates were placed symmetrically in four positions in the deposition chamber. RF power was varied between 30 and 155 watts, substrate heights were varied using glass spacers between 0 and 7 mm and gas flow rate ratios were varied between 25 and 45% CH₄ - H₂ ratios. The films were characterized using mass determination, profilometry, ellipsometry and FTIR. These characterization techniques were used to determine the important main and interaction effects associated with dlc film deposition.

MONDAY, AUGUST 21, 1995
12:00 PM
ROOM 101, HINES HALL

III. FINAL FINANCIAL STATEMENT (For months ending July, August and September, 1995)*

1)	STUDENT WAGES.....			50,976.00
	Amt. Encumbered/	Date		
	Spent: 50,971.00	9/30/95	Balance:	<u>5.00</u>
2)	LAB SUPPLIES.....			22,531.00
	Amt. Encumbered/	Date		
	Spent: 22,523.00	9/30/95	Balance:	<u>8.00</u>
3)	OFFICE SUPPLIES.....			283.00
	Amt. Encumbered/	Date		
	Spent: 281.00	9/30/95	Balance:	<u>2.00</u>
4)	OFFICE EQUIPMENT.....			760.00
	Amt. Encumbered/	Date		
	Spent: 753.00	9/30/95	Balance:	<u>7.00</u>
5)	SCIENTIFIC EQUIP.....			12,635.00
	Amt. Encumbered/	Date		
	Spent: 12,628.00	9/30/95	Balance:	<u>7.00</u>
6)	TRAVEL.....			8,735.00
	Amt. Encumbered/	Date		
	Spent: 8,443	9/30/95	Balance:	<u>292</u>

* Expenditure and balance entries are from P. I. records, except where indicated from attached University Records

Financial Statement (cont.)

for months ending July, August, September, 1995

7) MAINTENANCE.....			0.00
Amt. Encumbered/	Date		(3,000 transferred)
Spent: 0	9/30/95	Balance:	0.00
8) EPA SALARIES.....			138,640.00
Amt. Encumbered/	Date		
Spent: 138,640.00	9/30/95	Balance:	0.00
9) FRINGES.....			33,274.00
Amt. Encumbered/	Date		
Spent: -	9/30/95	Balance: 10,738.94	
		(University Records)	
10) INDIRECT COSTS.....			107,182.00
Amt. Encumbered/	Date		
Spent: -	9/30/95	Balance: 15,252.41	
		(University Records)	

Total Contract Period: September 29, 1992 to September 30, 1995

Total Contract Amount: \$378,271

Funding to Date: \$378,271

DATE RUN 08/09/95
 TIME RUN 21:08:31
 FBM090 - A5

NORTH CAROLINA AGRICULTURAL AND TECHNICAL STATE UNIVERSITY
 FINANCIAL RECORDS SYSTEM
 ACCOUNT STATEMENT FOR 07/31/95

REPORT PAGE 2526
 PROGRAM ID FBM092
 ACCOUNT PAGE 1

ACCT: 4-41065
 DEPT: 10124

A STUDY OF DIAMON AND DIAMOND-LIKE THIN FILMS

TO: WILLIAMS, ELVIRA
 PHYSICS

SUB CODE DESCRIPTION	BUDGETS		ACTUALS		OPEN COMMITMENTS	BALANCE AVAILABLE	PERC USED
	ORIGINAL	REVISED	CURRENT MONTH	FISCAL YEAR			
0241 FED C & G DIR COST	200,000-	378,271.00-	300,331.87-			77,939.13-	79
TOTAL REVENUES	200,000-	378,271.00-	300,331.87-			77,939.13-	79
1110 EPA REGULAR SALARIES	65,604	138,640.00	113,223.21			25,416.79	81
1410 NON-STUDENT REG WAGE		3,255.00	2,946.00			309.00	90
1450 STUDENT REGULAR WAGE	34,739	50,976.00	50,975.50			50.50	99
1550 UNEMPLOYMENT COMP		597.73	598.05			.32-	100
TEMPORARY EMPLOYEE W	34,739	54,828.73	54,519.55			309.18	99
1800 STAFF BENEFITS	15,745	10,738.94				10,738.94	0
1810 SOCIAL SECURITY		8,555.04	8,555.04				100
1820 STATE RETIREMENT		5,522.99	5,522.99				100
1830 MEDICAL INSURANCE		2,795.97	53.72	53.72			100
1870 IIAA OPT RETIREMENT		5,063.33	5,063.33				100
STAFF BENEFITS	15,745	32,676.27	53.72	53.72	21,937.33	10,738.94	67
TOTAL PERSONNEL COMP	116,088	226,145.00	53.72	53.72	189,680.09	36,464.91	83
2302 LABORATORY SUPPLIES	10,000	22,531.00			16,494.14	6,036.86	73
2601 OFFICE SUPPLIES	123	283.00			249.13	33.87	88
SUPPLIES AND MATERIA	10,123	22,814.00			16,743.27	6,070.73	73
3100 TRAVEL	8,000	1,934.49				1,934.49	0
3111 IN-STATE TRANSPORT		60.00	60.00	60.00	60.00		100
3119 IN-STATE OTHER TRAVE		679.75	679.75	679.75	679.75		100
3121 OUT-OF-STATE TRANSP		1,558.00			1,558.00		100
3122 OUT-OF-STATE SUBSIST		3,230.00			3,230.00		100
3129 OUT-OF-STATE OTH TRA		1,272.76			1,272.76		100
CURRENT SERVICES	8,000	8,735.00	739.75	739.75	6,800.51	1,934.49	77
4401 BUILDING MAINTENANCE	3,000						0
4801 INDIRECT COSTS	55,189	107,182.00			91,929.59	15,252.41	85
FIXED CHARGES	58,189	107,182.00			91,929.59	15,252.41	85
5101 OFFICE EQUIPMENT	1,600	760.00			710.00	50.00	93
5302 SCIENTIFIC EQUIP	6,000	12,635.00			11,664.42	970.58	92

DATE RUN 08/09/95
 TIME RUN 21:08:31
 FBMO90 - A5

NORTH CAROLINA AGRICULTURAL AND TECHNICAL STATE UNIVERSITY
 FINANCIAL RECORDS SYSTEM
 ACCOUNT STATEMENT FOR 07/31/95

REPORT PAGE 2527
 PROGRAM ID FBMO92
 ACCOUNT PAGE 2

ACCT: 4-41065
 DEPT: 10124

A STUDY OF DIAMON AND DIAMOND-LIKE THIN FILMS

TO: WILLIAMS, ELVIRA
 PHYSICS

SUB CODE DESCRIPTION	-----BUDGETS-----		-----ACTUALS-----			OPEN COMMITMENTS	BALANCE AVAILABLE	PERC USED
	ORIGINAL	REVISED	CURRENT MONTH	FISCAL YEAR	PROJECT YEAR			
CAPITAL OUTLAY	7,600	13,395.00			12,374.42		1,020.58	92
TOTAL OTHER EXPENSES	83,912	152,126.00	739.75	739.75	127,847.79		24,278.21	84
TOTAL EXPENSES	200,000	378,271.00	793.47	793.47	317,527.88		60,743.12	83
ACCOUNT TOTAL			793.47	793.47	17,196.01		17,196.01	0

PLEASE REVIEW THIS SUMMARY OF YOUR ACCOUNT TRANSACTIONS & BALANCES.
 IF YOU HAVE QUESTIONS, CONTACT LAVERNE CARTER (ACCOUNTING, -7684).

DATE RUN 08/09/95
 TIME RUN 21:08:31
 FBMO91

ACCT: 4-41065
 DEPT: 10124

NORTH CAROLINA AGRICULTURAL AND TECHNICAL STATE UNIVERSITY
 FINANCIAL RECORDS SYSTEM
 REPORT OF TRANSACTIONS FOR 07/31/95

REPORT PAGE 2528
 PROGRAM ID FBMO92
 ACCOUNT PAGE 1

TO: WILLIAMS, ELVIRA
 PHYSICS

A STUDY OF DIAMON AND DIAMOND-LIKE THIN FILMS

SUB CODE	DESCRIPTION	DATE	TC	REF.	2ND REF.	U.E. OFFSET ACCOUNT	BUDGET ENTRIES	REV/EXP	COMMITMENTS	BATCH REF. DATE
1830	HEALTH INS - I T F	07/31	069		S.H.P.			53.72		CJEO10 071495
1830	CM TOTAL MEDICAL INSURANCE							53.72		
3111	ELVIRA WILLIAMS	07/13	048	C40294	215554			20.00		APC088 071395
	ELVIRA WILLIAMS	07/13	048	C40295	215554			20.00		APC088 071395
	ELVIRA WILLIAMS	07/20	048	C40522	215862			20.00		APC092 072095
3111	CM TOTAL IN-STATE TRANSPORT							60.00		
3119	ELVIRA WILLIAMS	07/13	048	C40294	215554			3.00		APC088 071395
	ELVIRA WILLIAMS	07/13	048	C40295	215554			3.75		APC088 071395
	AAA TRAVEL AGENCY	07/13	048	C40296	215597			673.00		APC088 071395
3119	CM TOTAL IN-STATE OTHER TRAVE							679.75		
*** ACCOUNT TOTAL ***								793.47		

DATE RUN 09/11/95
 TIME RUN 10:34:24
 FBM090

NORTH CAROLINA AGRICULTURAL AND TECHNICAL STATE UNIVERSITY
 FINANCIAL RECORDS SYSTEM
 ACCOUNT STATEMENT FOR 08/31/95

REPORT PAGE 2485
 PROGRAM ID FBM092
 ACCOUNT PAGE 1

ACCT: 4-41065
 DEPT: 10124

A STUDY OF DIAMON AND DIAMOND-LIKE THIN FILMS

TO: WILLIAMS, ELVIRA
 PHYSICS

SUB CODE DESCRIPTION	-----BUDGETS-----		-----ACTUALS-----		OPEN COMMITMENTS	BALANCE AVAILABLE	PERC USED
	ORIGINAL	REVISED	CURRENT MONTH	FISCAL YEAR			
O241 FED C & G DIR COST	200,000	378,271.00	9,050.42	9,050.42	309,382.29	68,888.71	81
REVENUE SUBTOTAL	200,000	378,271.00	9,050.42	9,050.42	309,382.29	68,888.71	81
1110 EPA REGULAR SALARIES	65,604	138,640.00		113,223.21		25,416.79	81
1410 NON-STUDENT REG WAGE		3,255.00		2,946.00		309.00	90
1450 STUDENT REGULAR WAGE	34,739	50,976.00		50,975.50		.50	99
1550 UNEMPLOYMENT COMP		597.73		598.05		.32	100
1800 STAFF BENEFITS	15,745	10,738.94		8,555.04		10,738.94	0
1810 SOCIAL SECURITY		8,555.04		5,522.99			100
1820 STATE RETIREMENT		5,522.99		2,795.97			100
1830 MEDICAL INSURANCE		2,795.97	53.72	5,063.33			100
1870 TIAA OPT RETIREMENT		5,063.33					100
1000-1999 SUBTOTAL	116,088	226,145.00	53.72	189,680.09		36,464.91	83
2302 LABORATORY SUPPLIES	10,000	22,531.00		16,494.14		6,036.86	73
2601 OFFICE SUPPLIES	123	283.00		249.13		33.87	88
2000-2999 SUBTOTAL	10,123	22,814.00		16,743.27		6,070.73	73
1000-2999 SUBTOTAL	126,211	248,959.00	53.72	206,423.36		42,535.64	82
3100 TRAVEL	8,000	1,934.49				1,934.49	0
3111 IN-STATE TRANSPORT		60.00	60.00	60.00			100
3119 IN-STATE OTHER TRAVE		679.75	679.75	679.75			100
3121 OUT-OF-STATE TRANSP		1,558.00		1,558.00			100
3122 OUT-OF-STATE SUBSIST		3,230.00		3,230.00			100
3129 OUT-OF-STATE OTH TRA		1,272.76		1,272.76			100
3000-3999 SUBTOTAL	8,000	8,735.00	739.75	6,800.51		1,934.49	77
4401 BUILDING MAINTENANCE	3,000						0
4801 INDIRECT COSTS	55,189	107,182.00		91,929.59		15,252.41	85
4000-4999 SUBTOTAL	58,189	107,182.00		91,929.59		15,252.41	85
5101 OFFICE EQUIPMENT	1,600	760.00		710.00		50.00	93
5302 SCIENTIFIC EQUIP	6,000	12,635.00		11,664.42		970.58	92
5000-5999 SUBTOTAL	7,600	13,395.00		12,374.42		1,020.58	92
3000-6999 SUBTOTAL	73,789	129,312.00	739.75	111,104.52		18,207.48	85

DATE RUN 09/11/95
 TIME RUN 10:34:24
 FBMO90

NORTH CAROLINA AGRICULTURAL AND TECHNICAL STATE UNIVERSITY
 FINANCIAL RECORDS SYSTEM
 ACCOUNT STATEMENT FOR 08/31/95

RECORD PAGE 248
 PROGRAM 00 FBMO90
 ACCOUNT PAGE 2

A STUDY OF DIAMON AND DIAMOND-LIKE THIN FILMS

ACC 4-41065
 DEP 10124

S/C	CODE DESCRIPTION	BUDGETS		ACTUALS		OPEN	BALANCE	PER
		ORIGINAL	REVISED	CURRENT MONTH	FISCAL YEAR			
	EXPENSE SUBTOTAL	200,000	378,271.00	793.47	317,527.88		60,743.12	00
	*** ACCOUNT TOTAL ***			9,050.42-	8,256.95-	8,145.59	8,145.59	00

DATE RUN 09/11/95
TIME RUN 10:34:24
FBM091

NORTH CAROLINA AGRICULTURAL AND TECHNICAL STATE UNIVERSITY
FINANCIAL RECORDS SYSTEM
REPORT OF TRANSACTIONS FOR 08/31/95

REPORT PAGE 2487
PROGRAM ID FBM092
ACCOUNT PAGE 1

ACCT: 4-410ES
DEPT: 10124

A STUDY OF DIAMON AND DIAMOND-LIKE THIN FILMS

TO: WILLIAMS, ELVIRA
PHYSICS

SUB CODE	DESCRIPTION	DATE	TC	REF.	2ND REF.	J.E. OFFSET ACCOUNT	BUDGET ENTRIES	YTD REV/EXP	COMMITMENTS	BATCH REF.	DATE
0241	UST636661142390	08/03	030	M44107				5,371.44-		CR2654	080395
	UST 6366 61144350	08/28	030	E01097				3,055.55-		CR2693	082895
	UST 6366 61144351	08/28	030	E01099				623.43-		CR2693	082895
0241	** TOTAL FED C & G DIR COST							9,050.42-			
	*** ACCOUNT TOTAL ***							9,050.42-			

DATE RUN 10/06/95
 TIME RUN 05:29:55
 PROGRAM - AE

NCPT CAROLINA AGRICULTURAL AND TECHNICAL STATE UNIVERSITY
 FINANCIAL RECORDS SYSTEM
 ACCOUNT STATEMENT FOR 09/30/95

REPORT PAGE 2652
 PROGRAM ID FBM092
 ACCOUNT PAGE 1

ACCT: 4-41055
 DEPT: 10124

A STUDY OF DIAMOND AND DIAMOND-LIKE THIN FILMS

TO: WILLIAMS, ELVIRA
 PHYSICS

SUB CODE	DESCRIPTION	BUDGET'S			ACTUALS		OPEN COMMITMENTS	BALANCE AVAILABLE	PERC USED
		ORIGINAL	REVISED	CURRENT MONTH	FISCAL YEAR	PROJECT YEAR			
0241	FED C & S DIP COST	200,000-	378,271.00-		9,050.42-	309,382.29-		68,888.71-	81
	TOTAL REVENUES	200,000-	378,271.00-		9,050.42-	309,382.29-		68,888.71-	81
1110	EPA REGULAR SALARIES	65,604	128,640.00			113,223.21		25,416.79	81
1410	NON-STUDENT REG WAGE	34,739	3,255.00			2,946.00		309.00	90
1450	STUDENT REGULAR WAGE		50,976.00			50,975.50		.50	99
1550	UNEMPLOYMENT COMP		597.73			598.05		.32-	100
	TEMPORARY EMPLOYEE W	34,739	54,828.73			54,519.55		309.18	99
1800	STAFF BENEFITS	15,745	10,738.94			8,555.04		10,738.94	0
1810	SOCIAL SECURITY		8,555.04			5,522.99			100
1820	STATE RETIREMENT		2,795.97		53.72	2,795.97			100
1830	MEDICAL INSURANC		5,063.33			5,063.33			100
1870	TIAA OPT RETIREMENT								100
	STAFF BENEFITS	15,745	32,676.27		53.72	21,937.33		10,738.94	67
	TOTAL PERSONNEL COMP	116,068	226,145.00		53.72	189,680.09		36,464.91	83
2302	LABORATORY SUPPLIES	10,000	22,531.00			16,494.14	1,672.80	4,364.06	80
2501	OFFICE SUPPLIES	123	283.00			249.13		33.87	88
	SUPPLIES AND MATERIA	10,123	22,814.00			16,743.27	1,672.80	4,397.93	80
3100	TRAVEL	8,000	1,934.49			60.00		1,934.49	0
3111	IN-STATE TRANSPORT		60.00		60.00	60.00			100
3119	IN-STATE OTHER TRAVE		679.75		679.75	679.75			100
3121	OUT-STATE TRANSP		1,558.00			1,558.00			100
3122	OUT-STATE SUBSIST		3,230.00			3,230.00			100
3129	OUT-STATE OTH TRA		1,272.76			1,272.76			100
	CURRENT SERVICES	8,000	8,735.00		739.75	6,800.51		1,934.49	77
4401	BUILDING MAINTENANCE	3,000							0
4901	INDIRECT COSTS	55,189	107,182.00			91,929.59		15,252.41	85
	FIXED CHARGES	58,189	107,182.00			91,929.59		15,252.41	85
5101	OFFICE EQUIPMENT	1,600	760.00			710.00		50.00	93
5302	SCIENTIFIC EQUIP	6,000	12,635.00			11,664.42		970.58	92

NORTH CAROLINA AGRICULTURAL AND TECHNICAL STATE UNIVERSITY
FINANCIAL RECORDS SYSTEM
ACCOUNT STATEMENT FOR 09/30/95

TO: WILLIAMS, ELVIRA
PHYSICS

OPEN COMMITMENTS	BALANCE AVAILABLE	PERC USED
1,672.80	1,020.58	92
1,672.80	22,605.41	85
1,672.80	59,070.32	84
1,672.80	9,818.39-	0

BUDGETS	REVISED	CURRENT MONTH	ACTUALS	FISCAL YEAR	PROJECT YEAR
ORIGINAL					
7,600	13,395.00		12,374.42		
33,912	152,125.00	739.75	127,847.79		
200,000	378,271.00	793.47	317,527.88		
		8,256.95-	8,145.59		

PLEASE REVIEW THIS SUMMARY OF YOUR ACCOUNT TRANSACTIONS & BALANCES. IF YOU HAVE QUESTIONS, CONTACT LAVERNE CARTER (ACCOUNTING, -7684).

OPEN COMMITMENTS STATUS

DATE	DESCRIPTION	ORIGINAL AMOUNT	LIQUIDATING EXPENDITURES	ADJUSTMENTS	CURRENT AMOUNT
10/02	MAC WAREHOUSE	453.80			453.80
09/30	FISHER SCIENTIFIC CO	259.00			259.00
09/30	INTERNATIONAL WAFER	960.00			960.00
	** ACCOUNT TOTAL **	1,672.80			1,672.80

DIRECT YOUR PO QUESTIONS TO THE PURCHASING OFFICE (EXT. -7555).

NORTH CAROLINA AGRICULTURAL AND TECHNICAL STATE UNIVERSITY
 FINANCIAL RECORDS SYSTEM
 REPORT OF TRANSACTIONS FOR 09/30/95

REPORT PAGE 2657
 PROGRAM ID FBM092
 ACCOUNT PAGE 1

DATE RUN 10/06/95
 TIME RUN 05:28:56
 FBM092

TO: WILLIAMS, ELVIRA
 PHYSICS

ACCT: 4-41065
 DEPT: 10124

SUB CODE	DESCRIPTION	DATE	TO	REF.	J-E OFFSET ACCOUNT	BUDGET ENTRIES	REV/EXP	COMMITMENTS	REF.	BATCH	DATE
2302	FISHER SCIENTIFIC CO	09/30	050	6103413				259.00		PUR018	093095
	MAC WAREHOUSE	10/02	050	6103411				453.80		PUR018	100295
	INTERNATIONAL WAFER	09/30	050	6103426				960.00		PUR018	093095
2302	CM TOTAL LABORATORY SUPPLIES							1,672.80			
								1,672.80			

*** ACCOUNT TOTAL ***

APPENDICES

Appendix A
Proposed First-Year Task Schedule

Appendix A
Proposed First-Year Task Schedule

Tasks	Begin	End
Characterize Our Chamber	May 1992	Jun 1992
Coat Flat Glass Samples	Jun 1992	Jul 1992
Characterize Glass Samples	Jul 1992	Aug 1992
Coat Aluminum/Alumina On Glass Samples	Aug 1992	Sep 1992
Characterize Aluminum/Alumina Samples	Sep 1992	Oct 1992
Coat Flat Copper Samples	Oct 1992	Nov 1992
Characterize Copper Samples	Nov 1992	Dec 1992
Coat Flat Composites/Polymides	Jan 1993	Feb 1993
Characterize Composites/Polymides	Feb 1993	Mar 1993
Coat Flat Metals Other Than Copper	Mar 1993	Apr 1993
Characterize Metal Samples	Apr 1993	May 1993

Appendix B
Revised First-Year Task Schedule

Appendix B
Revised First-Year Task Schedule

The principal investigator and both co-directors met with Mrs. Marilyn Freeman, Contracting Office Representative, at North Carolina A&T State University on 11 January 93 and together generated the following revised technical plan which represents a more realistic scheme considering the time the award was made (near the end of the Fall Semester):

<u>PROCEDURE</u>	<u>DATE</u>
Characterize Deposition Chamber (x,y,z optimization; coat silicon wafers using chemcore or microscope glass spacers)	January - May, 1993
Characterize Films on Silicon <ul style="list-style-type: none"> - Thickness (weight averages, tally surfaces, interference) - Index of Refraction (ellipsometry) - Composition (F.T.I.R., Auger (?), X-ray diffraction) - Adherence (plasma cleaning to assist) - Hall Effect 	January - May, 1993
Review (COR and researchers meeting) <ul style="list-style-type: none"> - Examine Data - Examine Charts/graphs (describing experiments and results) - Strategize (based on results) 	May, 1993
Coat Al on Glass Samples Characterize Films (and glass)	June-August, 1993
Coat Al ₂ O ₃ on glass samples Characterize Films (and glass)	
Review (COR and Researchers Meeting) <ul style="list-style-type: none"> - Examine Data - Examine Charts/Graphs (describing experiments and results) - Strategize (based on results) 	August, 1993
Begin Coating Copper Films on Glass	September, 1993

Appendix C
Schematic Diagram of Deposition Chamber

A schematic diagram of a capacitively coupled radio frequency Reactive Plasma Deposition (RPD) system

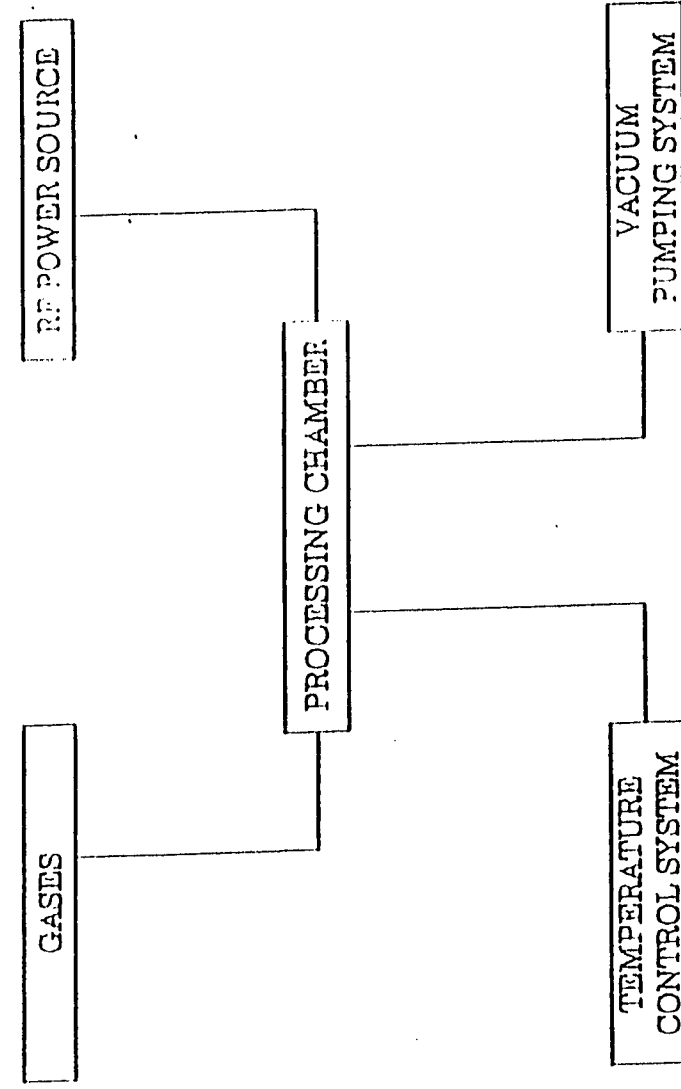

PLASMA DEPOSITION SYSTEM

Appendix D
Photograph of Deposition Chamber Showing
Baseplate, Cover and Some DLC Films on Baseplate

Appendix D
Photograph of Deposition Chamber Showing Baseplate, Cover
and Some DLC Films on Baseplate

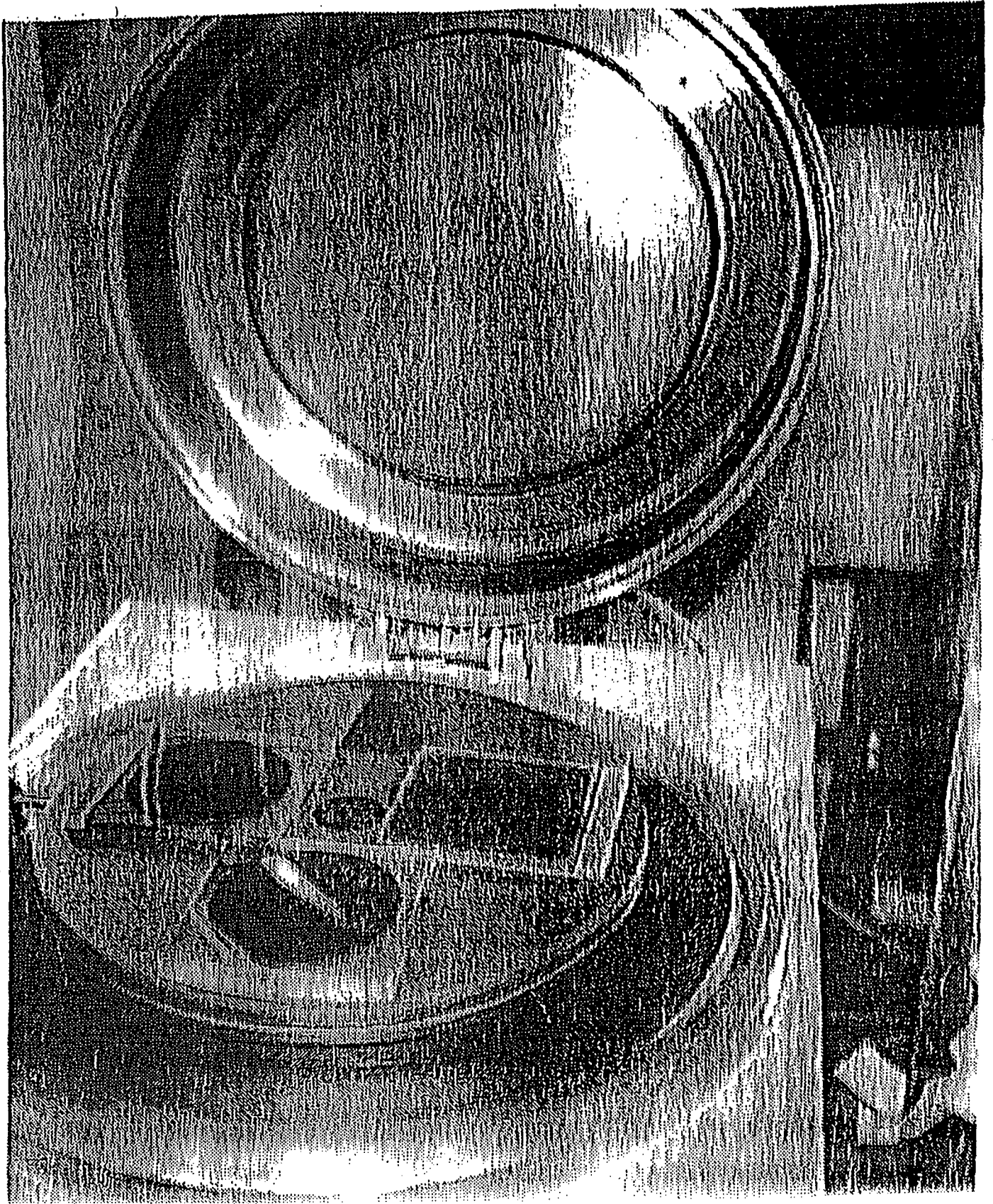

Processing Chamber Showing Baseplate, Cover and Some DLC Films on Baseplate.

Appendix E

Experiment #1 (discussed under section "c" below)

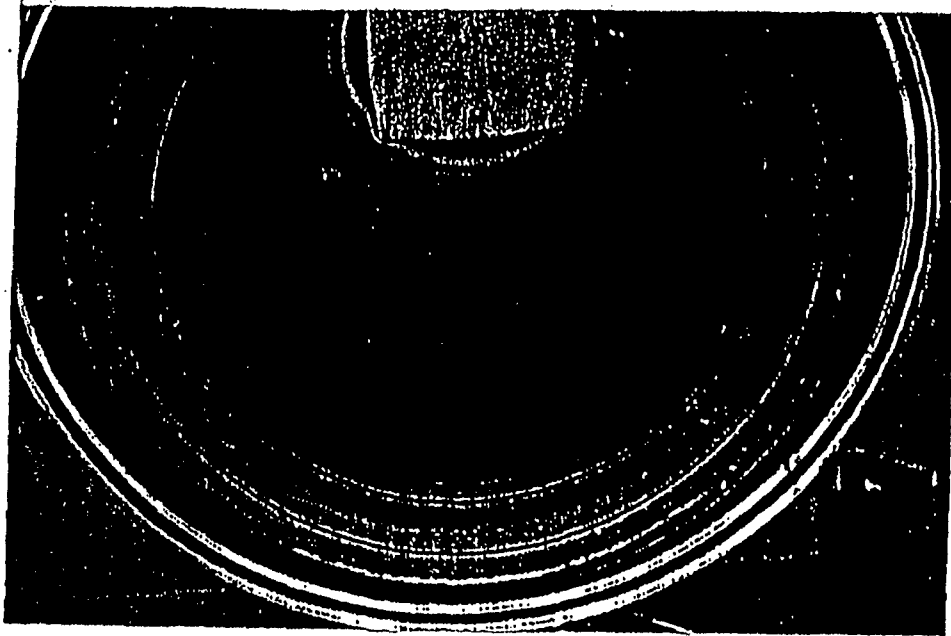

Figure B-3: Run #326-0°

Scientific Associations and Other Collaborative Efforts

The members of the Diamond-Thin Films Team at A&T keep in close contact, not only among themselves but also with team members at the University of Texas at Austin (UT) and at Picatinny Arsenal. During this quarter, team members have exchanged technical and other information not only through telephone conferences, faxes, written correspondence, etc., but also through the following activities:

a. Weekly Seminars

The A&T faculty and student researchers engaged in weekly technical seminars for information exchange topics related to the ARDEC project.

b. Scientific Meetings

The principal investigator, eight (8) undergraduate student researchers and one (1) graduate student, attended the National Society of Black Physicists Conference in Tallahassee, Florida on April 21-24, 1993. Three (3) undergraduate students presented papers and three others presented posters at that meeting. That meeting was substituted for the two (2) planned Summer 1992 meetings.

c. Technical Meeting at A&T

Marilyn Freeman of the Institute of Advanced Technology at the University of Texas (UT) at Austin and the Electrical Armament Division at ARDEC met with A&T ARDEC faculty (Elvira Williams and Johnnie Richardson from the Department of Physics and Alvin Kennedy from the Department of Chemistry) and students, June 16-18, 1993. Technical accomplishments during that meeting included: future project experiments, contamination reduction during processing, sharing of technical papers related to the project and joint performance of project experiments (see Figure B-8) by A&T and UT Team members.

One of these experiments was designated Experiment #1 since it was the first joint A&T/IAT that was done on a substrate prepared by ARDEC. In Experiment #1 a DLC film was placed on an Aluminum substrate prepared by ARDEC. All ARDEC samples were mounted on 7 mm high glass plates.

d. Technical Meeting at Picatinny Arsenal

The A&T faculty researchers and Marilyn Freeman met at Picatinny Arsenal with Kern Strickland and Greg Peppertrefon of the Nuclear Division July 14-15, 1993. Also present at that meeting were: Dr. T. Richard Jow, Research Physical Scientist at Fort Monmouth, NJ and Dr. W.J. Sergeant, James Clerk Maxwell, Professor of the State University of New York at Buffalo.



Figure B-8 (1-1): Undergraduate A&T researcher, Daryl Moore, UT/ARDEC researcher, Marilyn Freeman and graduate student, Donald Anderson

Prior to the A&T faculty researchers arrival at this meeting, Marilyn Freeman had film thickness measurements made at ARDEC on one sample film made at A&T during her June trip there. This thickness was 0.18 microns. The thickness needs to be at least 0.50 microns. Ms. Freeman had deliberately brought the films made at A&T to the ARDEC meeting in compact, closed containers in hot weather via standard airport luggage handling procedures as a wear test. They were observed to have

begun to sweat and to flake around the substrate edges. Also adhesion tests of the DLC film on the glass mount of the ARDEC Al substrate had been done back at A&T using acetone, km wipes, fingernail and scotch tape. It passed all of these tests except, the scotch tape.

Other accomplishments at the ARDEC meeting included reports on: 1) the contract status and the recent visit to A&T by Marilyn Freeman, 2) technical accomplishments to date and chamber characterization results by Elvira Williams, 3) IR analysis of DLC films to date by Alvin Kennedy, and 4) analytical tools or techniques required for film characterization and desired equipment list by Johnnie Richardson.

Figure C-2

Normalized Deposition Rate vs Power

Z = 7 mm

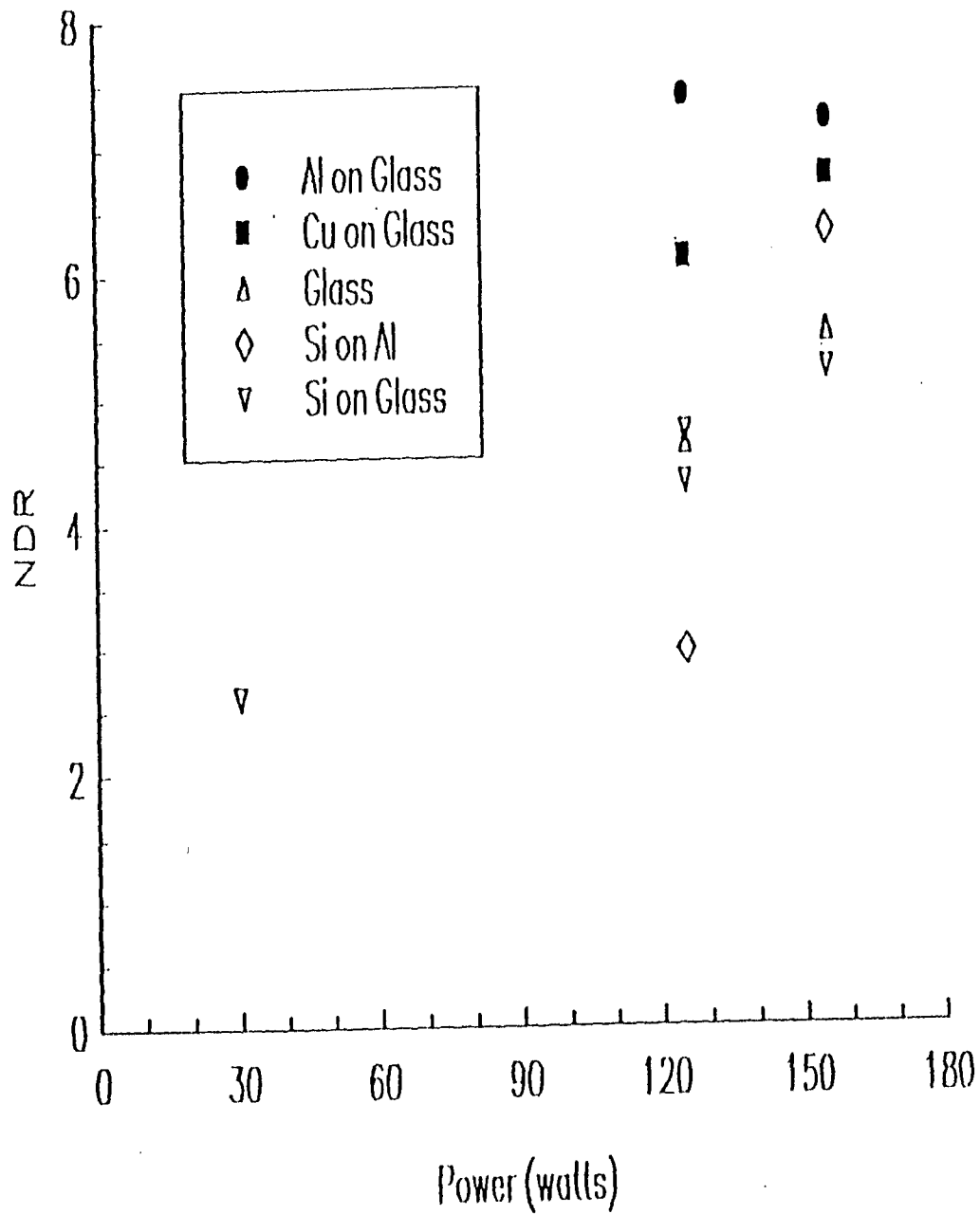

scans/spot) were taken at four different locations on each wafer. Each location was approximately 90° from each other.

Figures C-3 and C-4 shows the FTIR spectra between 1350 and 1150 cm^{-1} as a function of height for 30 and 120 watts respectively. All spectra have a peak at 1440 cm^{-1} which corresponds to a CH_2 or CH_3 deformation. This is consistent with the termination of diamond region in the film by these groups.

Figures C-5 and C-6 shows the FTIR spectra between 2600 and 3200 cm^{-1} as a function of height for 30 and 120 watts respectively. The weak spectra at 7mm and 14mm for the 30 watt spectra are the result of the lower transmission Si wafers used. All spectra display a peak near 2920 cm^{-1} which corresponds to a C-H stretch in a CH_2 function group. This strongly suggests that the DLC films are terminated with CH_2 as opposed to CH_3 .

Figure C-3

FTIR Transmission Spectra vs Height at 30 watts
CH₂ Asymmetric stretch

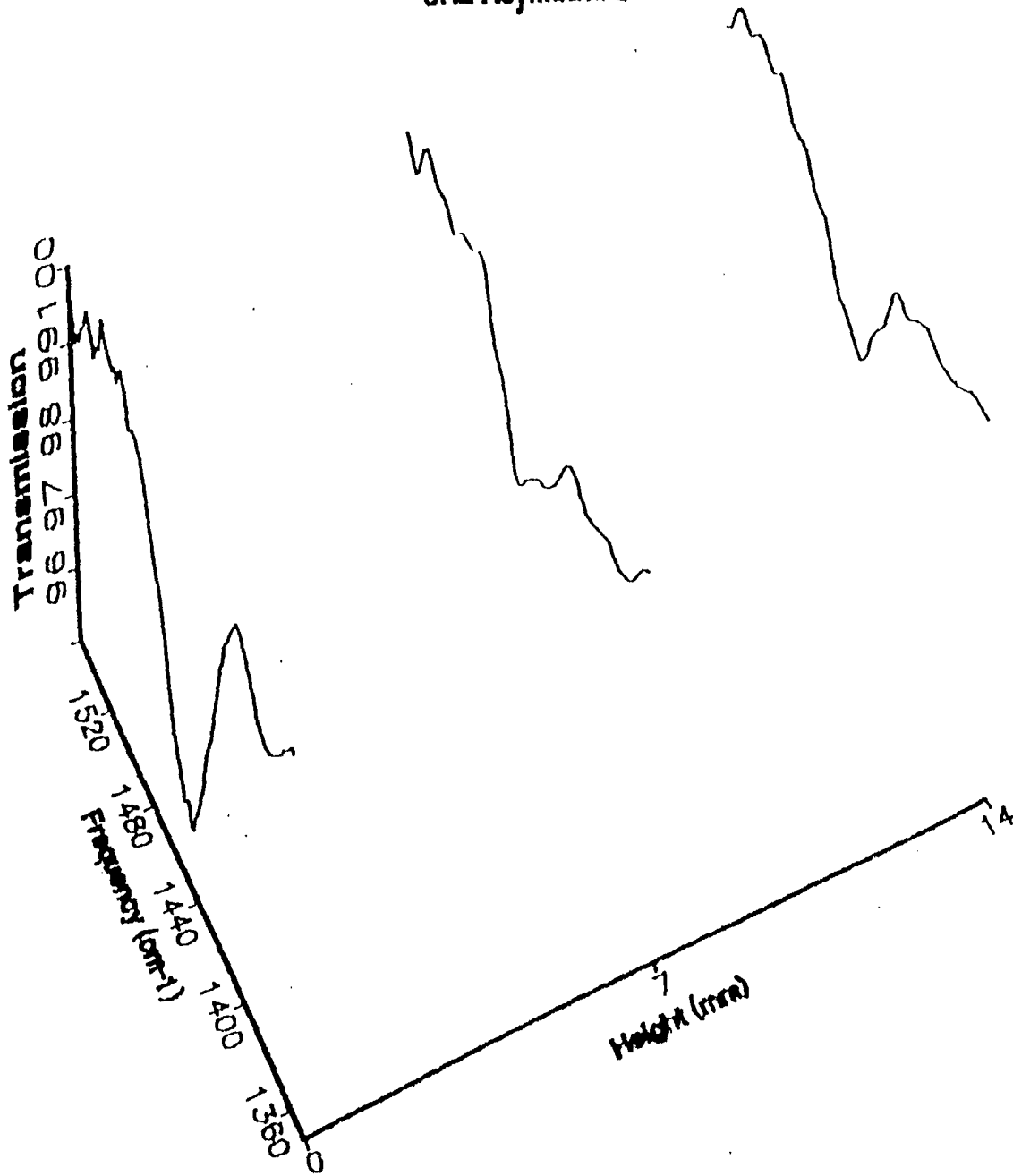

Figure C-4

FTIR Transmission Spectra vs Height at 120 watts
CH₂ Asymmetric stretch

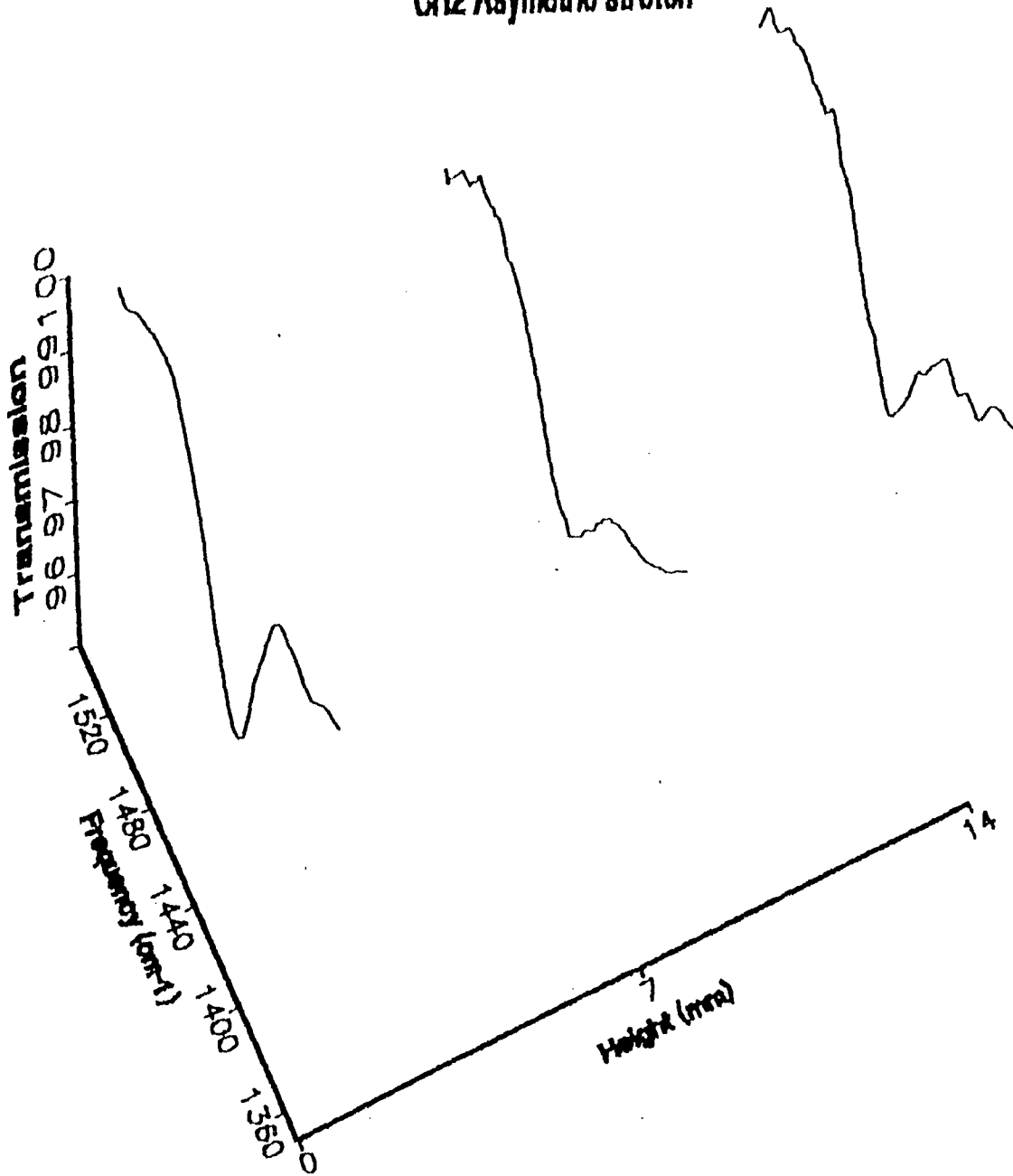

Figure C-5

FTIR Transmission Spectra vs Height at 30 watts CII Stretch region

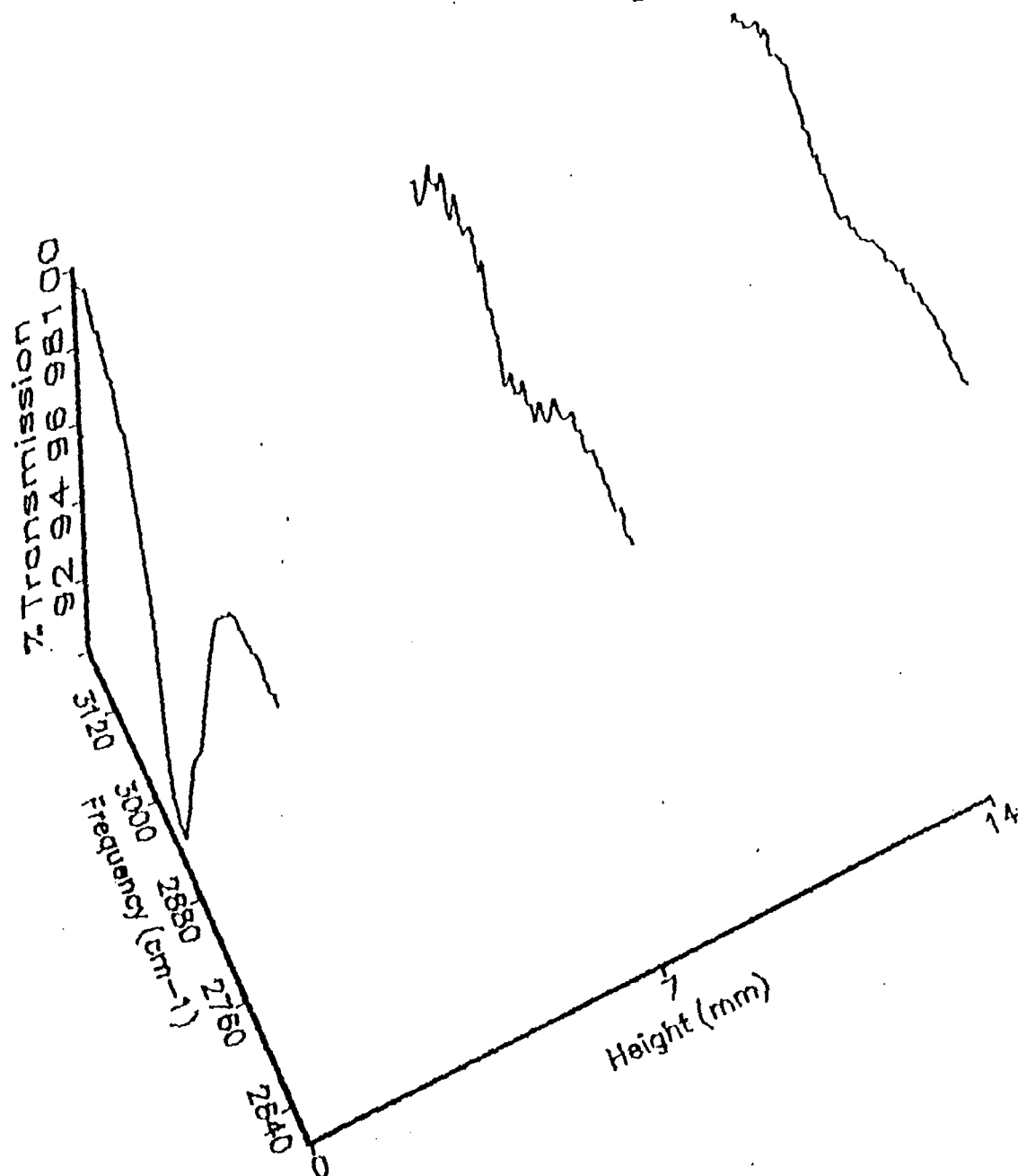
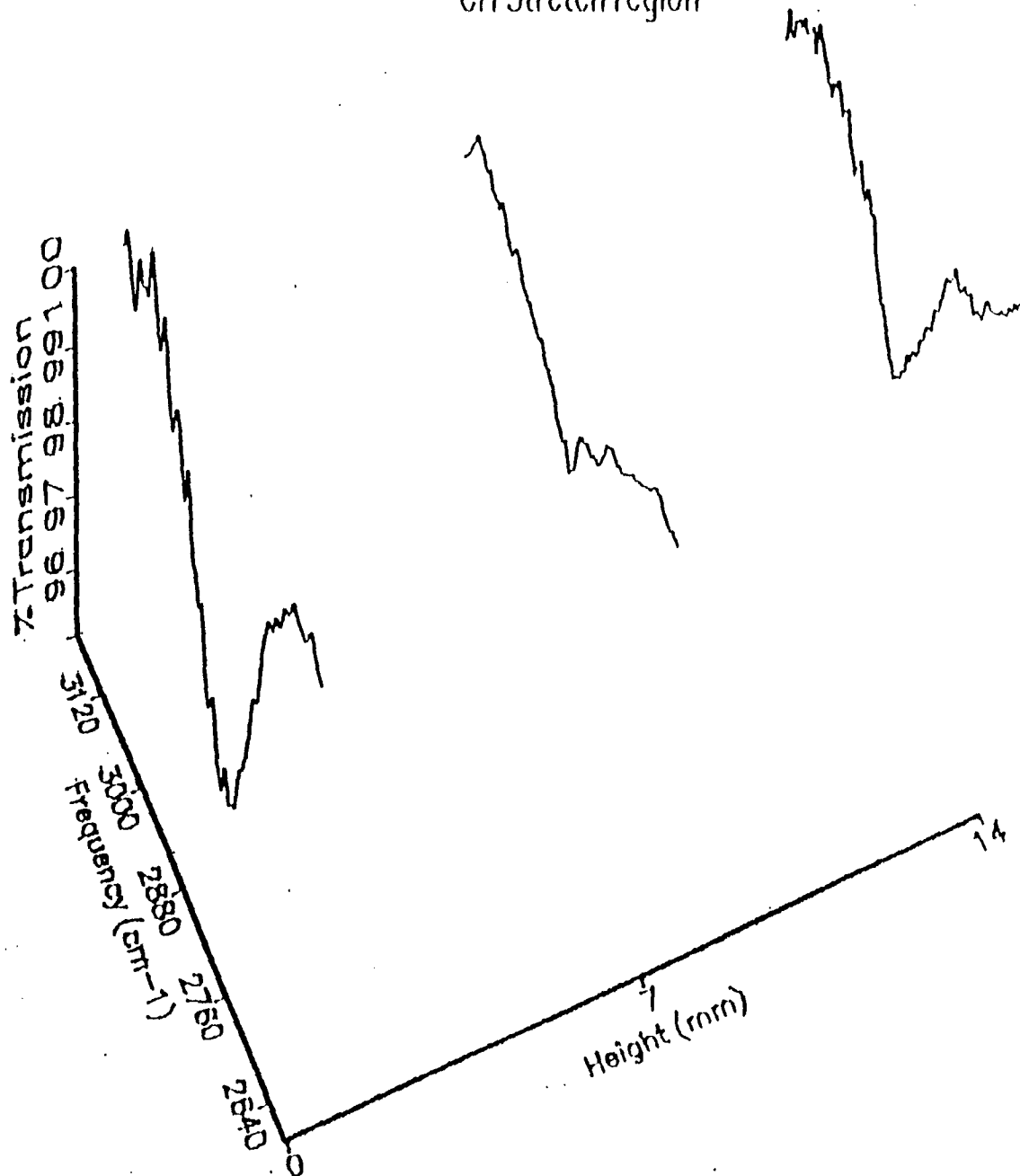

Figure C-6

FTIR Transmission Spectra vs Height at 120 walls
CH Stretch region



Figures C-7 and C-8 shows the FTIR spectra between 1550 and 1800 cm^{-1} as a function of height for 30 and 120 watts respectively. Figure C-8 shows strong IR peaks between 1600 cm^{-1} and 1650 cm^{-1} , which is the spectral region where carbon double bond stretches (C=C) usually appear. This suggest that at this power more unsaturated carbon or graphite type compositions are being formed. These carbon-carbon double bond features are present at all heights. There is no indication that similar structures are formed at a power of 30 watts (Figure C-7).

3. Summary

- A) The deposition composition is strongly dependent upon the power. High power levels (120 watts) tends to produce more graphite like carbon structures.

- B) The deposition rate is strongly dependent upon the power, and increases as the power increases.

Figure C-7

FTIR Transmission Spectra vs Height at 30 Walls
C=C Stretch region

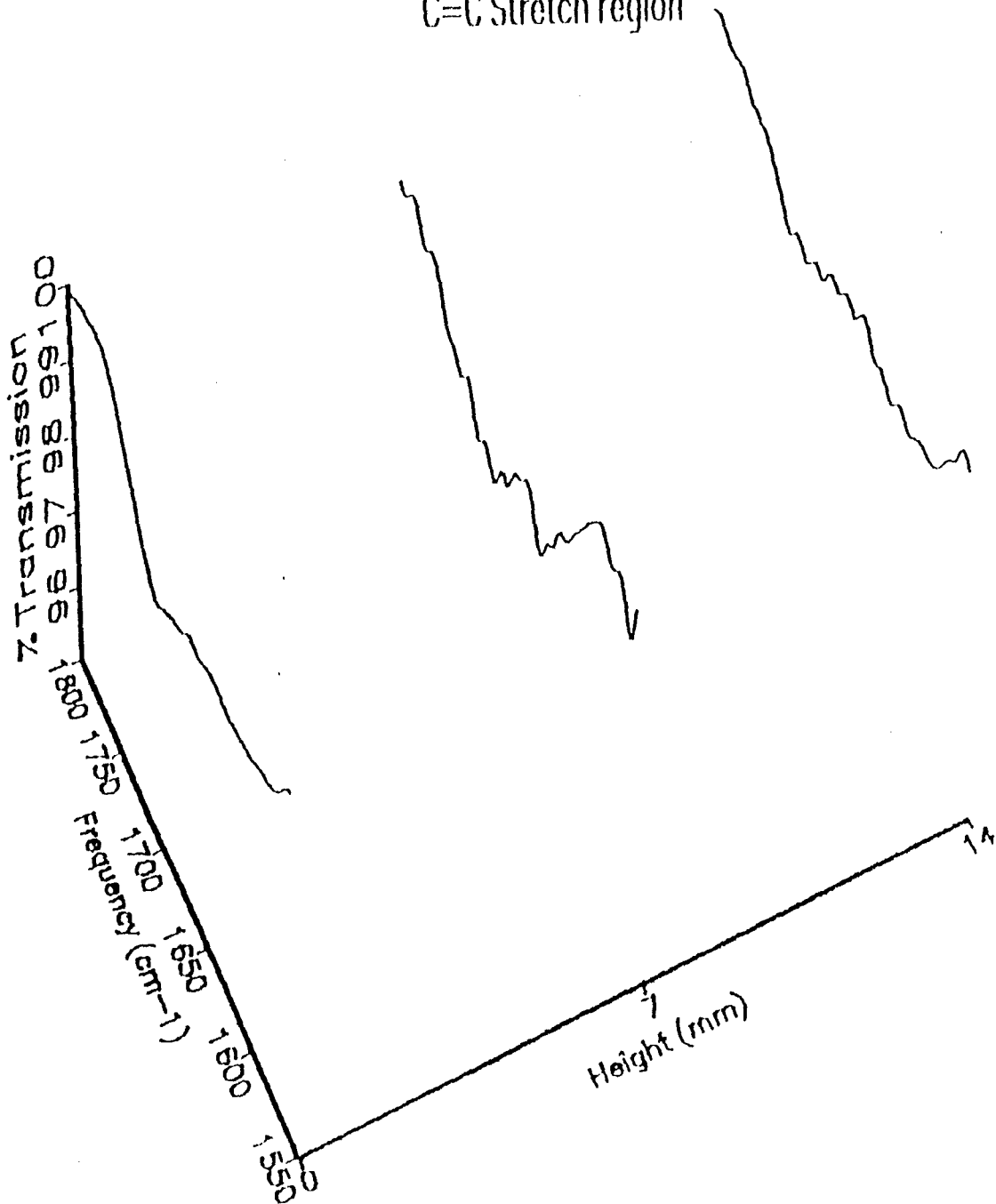
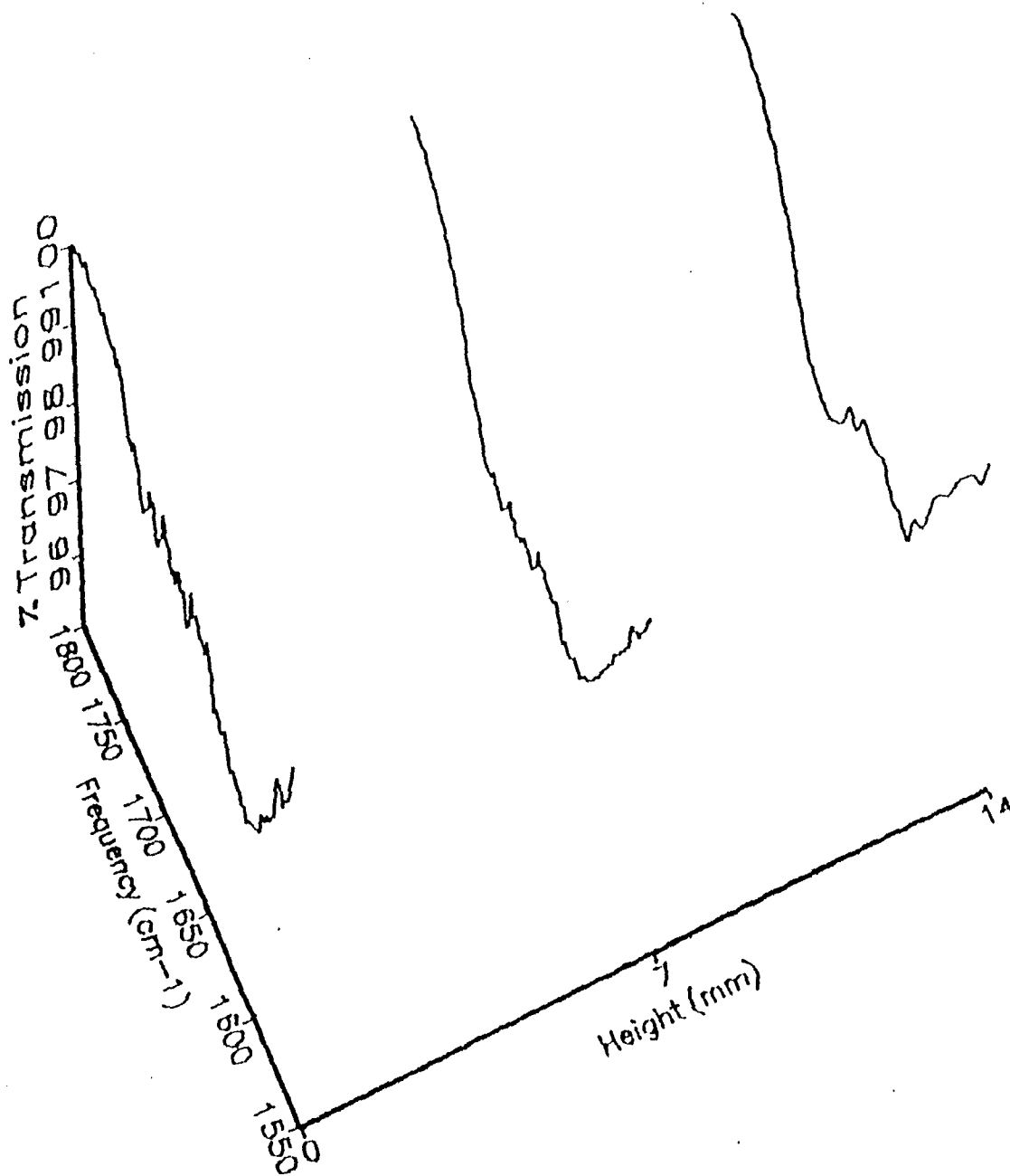

Figure C-8

FTIR Transmission Spectra vs Height at 120 Watts
C=C Stretch region



C) The deposition rate appears to decrease as the height of the substrate in the chamber increases.

D) The type of substrate and spacer used seems to affect the deposition rate.

D. Electric Field Approximation at Film Surface for Metal and Glass Spacers

Preliminary modelling of the electric field between the plates of a parallel plate capacitor (representations of the deposition chamber) follows on the next several pages.

In these models, the assumptions made are: (1) the localized electric field above a substrate on glass or metal spacers predominates, (2) vacuum, spacers, substrates, DLC films, all with area A , form a series capacitor arrangement, (3) the top capacitor plate is at 440 volts.

Also in these models, the following symbols have been defined:

- C = capacitance
- ϵ_0 = permittivity of free space
- A = area
- d = distance between capacitor plates
- U = the energy
- V = the voltage
- k = the dielectric constant

The different k's represent the regions of different dielectric constant between the capacitor plates. For example, in model #5, k1, k2, k3, and k4 might represent the dielectric constant for a glass spacer, a silicon substrate, a DLC film, and a vacuum, respectively. Preliminary numerical values that approximate those of the dielectrics used in our basic DLC experiments are explored using TK Solver Plus computer software to generate numbers that can be compared with real parameter values.

Equations used in the above models include:

$$\text{VOLUME} = A \cdot d$$

$$U = (1/2) C V^2$$

$$U = (1/2) \epsilon_0 \int k E^2 d\tau, \tau = \text{volume}$$

$$C = k \epsilon_0 (A/d) = k C_{\text{vacuum}}$$

$$1/C = (1/C_1) + (1/C_2) + (1/C_3) + \dots \dots \dots \text{(capacitors in series)}$$

S ile

"Modeling The Electric Field In The Deposition Chamber By
"Series And Parallel Parallel Plate Capacitors

"Model #1 - A Parallel Plate Capacitor In A Vacuum

$$C = \epsilon_0 \cdot A / d$$

$$U = (C \cdot V^2) / 2$$

$$U = (1/2) \cdot \epsilon_0 \cdot k \cdot (E^2) \cdot \text{volume}$$

$$\text{volume} = A \cdot d$$

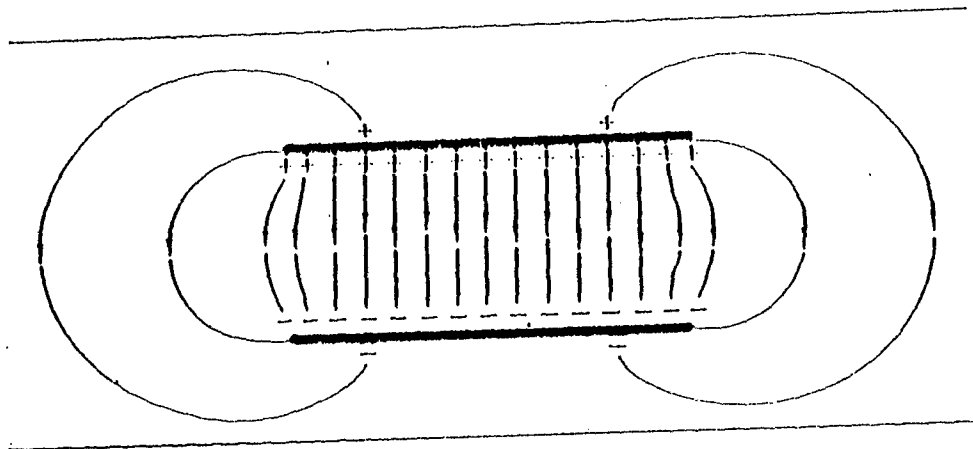

<u>St</u>	<u>Input</u>	<u>Name</u>	<u>Output</u>	<u>Unit</u>	<u>Comment</u>
		C	2.206E-12	farads	the capacitance
8.85E-12		e0		coulombss	
.0081		A		m	the area of the capacitor
.0325		d		m	the height of the capacitor gap
		U	2.1351E-7	joule	
440		V		volts	the potential at the top plate
1		k			
		E	9573.138	volts/m	the electric field
		volume	.00026325	mcubed	the volume of the dielectric

S Rule

"Model #2 - A parallel plate capacitor filled completely with
"a single dielectric k

$$C = k \cdot \epsilon_0 \cdot A / d$$

$$* U = C \cdot (V^2) / 2$$

$$* U = (1/2) \cdot \epsilon_0 \cdot k \cdot (E^2) \cdot \text{volume}$$

$$* \text{volume} = A \cdot d$$

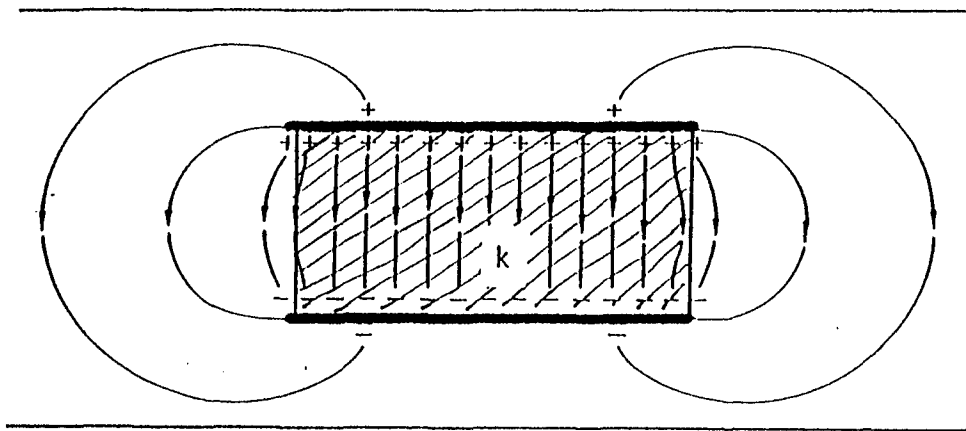

<u>St</u>	<u>Input</u>	<u>Name</u>	<u>Output</u>	<u>Unit</u>	<u>Comment</u>
		C	1.741E-11	farads	
	1.7	k			
	8.85E-12	e0		coulombss	
	? .0081	A		msq	
	.007	d		m	
		U	1.6852E-6	joules	
	440	V		volts	
		E	44446.712	volts/m	
		volume	? .0000567	mcubed	

S. Rule

Model #3 - A parallel plate capacitor filled with dielectrics k1 and k2

- * $C = (2 \cdot \epsilon_0 \cdot A / d) \cdot ((k_1 \cdot k_2) / (k_1 + k_2))$
- * $U = C \cdot (V^2) / 2$
- * $U_1 = (1/2) \cdot \epsilon_0 \cdot k_1 \cdot (E_1^2) \cdot \text{volume}_1$
- * $U_2 = (1/2) \cdot \epsilon_0 \cdot k_2 \cdot (E_2^2) \cdot \text{volume}_2$
- * $\text{volume}_1 = A \cdot d_1$
- * $\text{volume}_2 = A \cdot d_2$
- * $E = \alpha \cdot E_1$
- * $E = \beta \cdot E_2$
- * $U = U_1 + U_2$

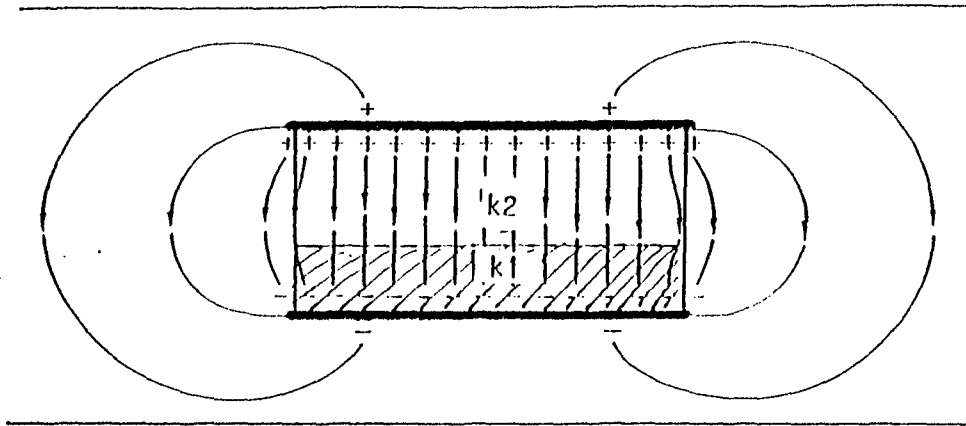

<u>St</u>	<u>Input</u>	<u>Name</u>	<u>Output</u>	<u>Unit</u>	<u>Comment</u>
		C	2.869E-12	farads	
		k			
	8.85E-12	e0		coulombss	
	.0081	A		msq	
	.0325	d		m	
		U	2.7771E-7	joules	
	440	V		mcubed	
	13538	E		volts/m	
		volume		mcubed	
	1.86	k1			
	1	k2			
		U1	9.5004E-7	joules	
		E1	45119.647	volts/m	
		volume1	.0000567	mcubed	
		U2	3.4174E-7	joules	
		E2	19336.445	joules	
		volume2	.00020655	mcubed	
	.007	d1		m	
	.0255	d2		m	
G	.30004667	alpha			
	.7001287	beta			

S. Rule

"Model #4 - A parallel plate capacitor filled with
"three dielectrics k_1, k_2, k_3

- * $(1/C) = (d_1/k_1 \cdot \epsilon_0 \cdot A) + (d_2/k_2 \cdot \epsilon_0 \cdot A) + (d_3/k_3 \cdot \epsilon_0 \cdot A)$
- * $U = C \cdot (V^2)/2$
- * $U_1 = (1/2) \cdot \epsilon_0 \cdot k_1 \cdot (E_1^2) \cdot \text{volume}_1$
- * $U_2 = (1/2) \cdot \epsilon_0 \cdot k_2 \cdot (E_2^2) \cdot \text{volume}_2$
- * $U_3 = (1/2) \cdot \epsilon_0 \cdot k_3 \cdot (E_3^2) \cdot \text{volume}_3$
- * $\text{volume}_1 = A \cdot d_1$
- * $\text{volume}_2 = A \cdot d_2$
- * $\text{volume}_3 = A \cdot d_3$
- * $E = \alpha \cdot E_1$
- * $E = \beta \cdot E_2$
- * $E = \gamma \cdot E_3$
- * $U = U_1 + U_2 + U_3$

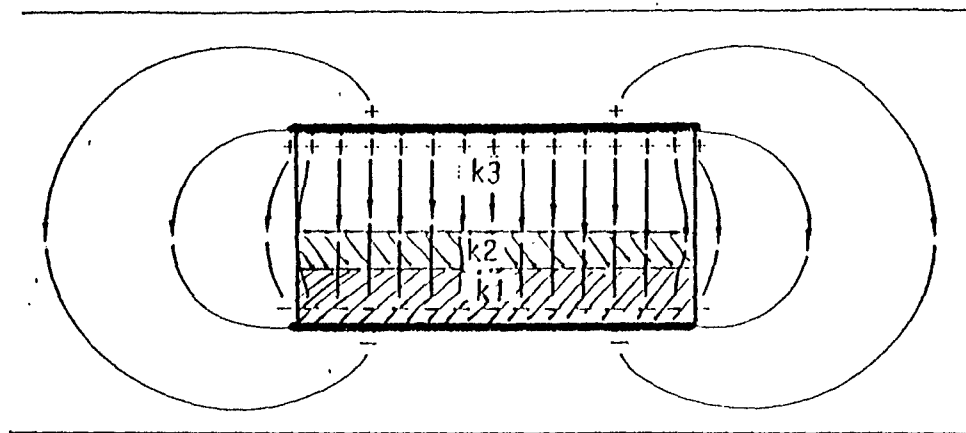

<u>St</u>	<u>Input</u>	<u>Name</u>	<u>Output</u>	<u>Unit</u>	<u>Comment</u>
		C		farads	
	1.86	k1			
	2	k2			
	1	k3			
		volume1		mcubed	
		volume2		mcubed	
		volume3		mcubed	
	13538	E		volts/m	
		E1	67690	volts/m	
		E2	45126.667	volts/m	
		E3	27076	volts/m	
	30	U		joules	
		U1		joules	
		U2		joules	
		U3		joules	
	.2	alpha			
	.3	beta			
	.5	gamma			
	.0081	A		msq	
	.007	d		m	
		V		mcubed	
		d1		m	
		e0		coulombss	
		d2		m	
		d3		m	

S Rule

"Model #5 - A parallel plate capacitor filled with
"three dielectrics k1, k2, k3, k4

$$(1/C) = (d1/k1*e0*A) + (d2/k2*e0*A) + (d3/k3*e0*A) + (d4/k4*e0*A)$$

$$U = C*(V^2)/2$$

$$U1 = (1/2)*e0*k1*(E1^2)*volume1$$

$$U2 = (1/2)*e0*k2*(E2^2)*volume2$$

$$U3 = (1/2)*e0*k3*(E3^2)*volume3$$

$$U4 = (1/2)*e0*k3*(E4^2)*volume4$$

$$volume1 = A*d1$$

$$volume2 = A*d2$$

$$volume3 = A*d3$$

$$volume4 = A*d4$$

$$E = \alpha*E1$$

$$E = \beta*E2$$

$$E = \gamma*E3$$

$$E = \delta*E4$$

$$U = U1 + U2 + U3 + U4$$

$$d = d1 + d2 + d3 + d4$$

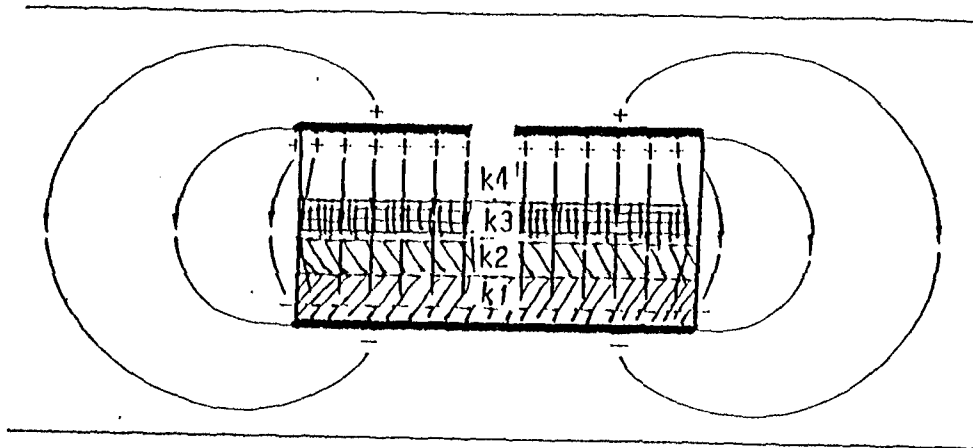

<u>St</u>	<u>Input</u>	<u>Name</u>	<u>Output</u>	<u>Unit</u>	<u>Comment</u>
		C	5.1891E14	farads	
	.007	d1		m	
	1.86	k1			
	8.85E-12	e0		coulombss	
	.0081	A		msq	
	.003	d2		m	
	2	k2			
	.0015	d3		m	
	2.42	k3			
		U	.00003611	joules	
		V	3.731E-10	volts	
		U1	2.1382E-6	joules	
		E1	67690	volts/m	
		volume1	.0000567	mcubed	
		U2	4.3794E-7	joules	
		E2	45126.667	volts/m	
		volume2	.0000243	mcubed	
		U3	1.4904E-7	joules	
		E3	33845	volts/m	
		volume3	.00001215	mcubed	
	13538	E		volts/m	
	.2	alpha			
	.3	beta			
	.4	gamma			
	.021	d4		m	
	1	k4			
		U4	3.3384E-5	joules	
		E4	135380	volts/m	
		volume4	.0001701	mcubed	
	.1	delta			
	.0325	d		m	

S Rule

References For Capacitors

"R.A. Serway, Physics For Scientists and Engineers
" With Modern Physics, Third Edition,
" pp. 726 - 731
"

"D. Haliday and R. Resnick, Fundamentals Of Physics,
" Second Edition, p. 501
"

"P.A. Tipler, Physics For Scientists and Engineers,
" Third Edition, pp. 690 - 709
"

"D.M. Trotter Jr., "Capacitors", Scientific American,
" July 1988, p. 86
"

"D.K. Cheng, Fundamentals of Engineering Electro-
" magnetics, Addison-Wesley, 1993
" pp. 116 - 142
"

"J.R. Reitz, F.J. Milford, and R.W. Christy,
" Foundations of Electromagnetic
" Theory, Addison-Wesley, 1993, pp.
" 150 - 153

Appendix F
Experiments #2 and #3, Maximum Milage
Experimental Set-up, Model of Electric Field in
Deposition Chamber

B. Fourth Quarter Technical Progress Report (Inclusive of Sections C,D)

During this reporting period, (July 27, 1993 - October 25, 1993) focus has been on: (1) continued characterization of the deposition chamber in the z-direction for diamond deposition on silicon substrates as standard and analysis of DLC films (See section C- below for discussion of details), (2) designing experiments to get the most mileage per experiment, (3) establishing a substrate cleaning (and etching) procedure, (4) deposition of DLC films on aluminum and copper substrates provided by ARDEC, (5) Electric Field approximations at film surface for metal and glass spacers.

1: Technical Meeting at A&T/Most-Mileage Experiment Designed

A collaborative research meeting was held at N.C. A&T State University on September 24-26, 1993. Attendees at the meeting on September 24, 1993 were: The A&T research team (Drs. Alvin Kennedy, Johnnie Richardson and Elvira Williams), Marilyn Freeman and Dr. Persad Chadee from the Institute of Advanced Technology (IAT) at the University of Texas at Austin. Attendees on September 25, 1993 were: Marilyn Freeman, Elvira Williams, Dawn Fant and Donald Anderson (Chemistry grad students), A. Akpan (lab assistant). Attendees on September 26, 1993 were: Marilyn Freeman, Alvin Kennedy, Elvira Williams, Dawn Fant, Donald Anderson, and A. Akpan. During the technical meeting on September 24, 1993, Dr. Chadee suggested the most-mileage experiment sketched below:

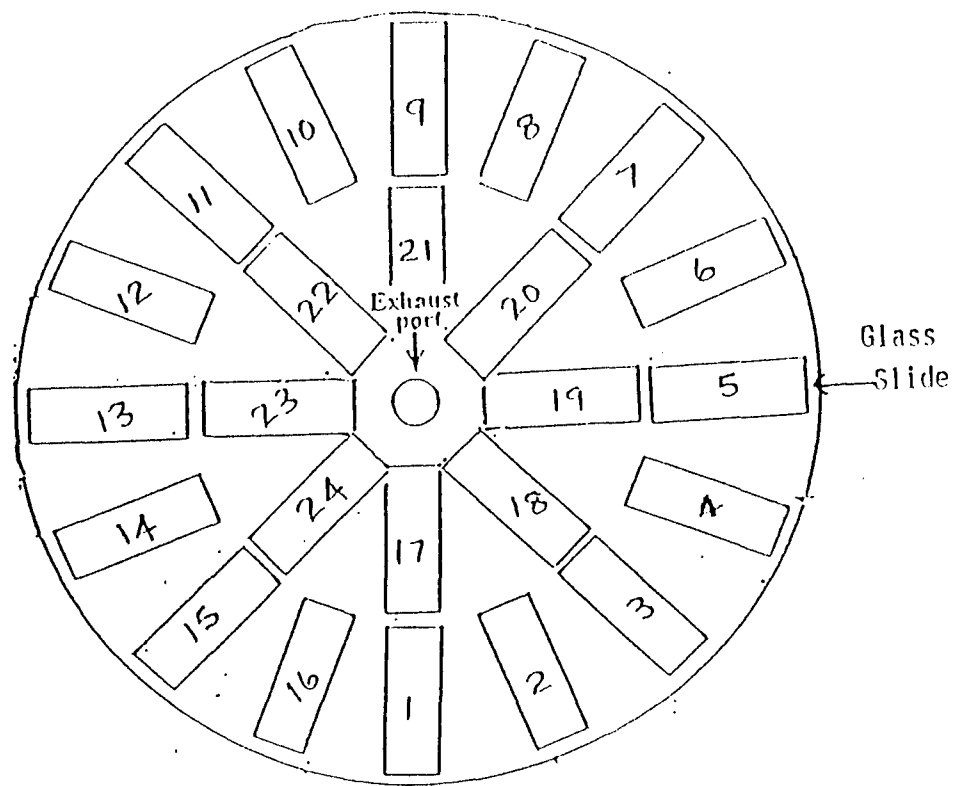

In this experiment, glass slides are to be placed around the chamber as

shown in stacks of 1,2,3,4, etc. as high as possible in the 32.5 mm high chamber. Repeat stacking until all chamber base is used. Place substrate chips on each slide stack and make a deposition run. Substrate chips may vary. e.g., Al, Cu, etc. Many experiments can be obtained from a single run. For example, deposition as a function of height, deposition as a function of substrate type, etc. The A&T team plans to do these experiments.

2. Technical Meeting at A&T/Substrate Cleaning and Etching Procedures Initiated

Substrate Cleaning (and Etching):

All substrates were cleaned using best available methods as follows:

Microscope Slides : Scrubbed with tap water and cheese cloth then rinsed with tap water and vapor dried in acetone vapor. (Acetone chemical grade)

Aluminum Sheets : Al sheet to be coated was pre- polished using tap water, cheese cloth and "Corning Cleaner and Conditioner", a polishing compound. This plate was then rinsed well in tap water and subsequently cleaned with same method as described below for rest of aluminum plates (for stacking). All aluminum plates were subjected to a 1-2 minute dip into room temperature concentrated Sodium hydroxide solution -etching- and then rinsed well in tap water. They were submerged in tap water then rinsed and vapor dried in acetone vapors.

Si Wafers : Si wafers were rinsed with acetone then tap water and vapor dried in acetone vapors repeatedly until the surface to be coated dried evenly and " looked clean". (n-type, p-doped)

ARDEC Plates : P-2, B-6, and A-12 were rinsed in tap water and repeatedly vapor cleaned in acetone vapors until the surface to be coated dried evenly when removed from the vapors and "appeared clean".

3. Deposition of DLC Films on Aluminum and Copper Substrates provided by ARDEC

During the second and third days of the Technical Meeting at A&T (September 25-26), two experiments were performed (run #367 or *Experiment #2* and run #368 or *Experiment #3*). The experiment performed during the June, 1993 collaborative technical meeting at A&T and reported in the Third Quarterly Report is referred to as *Experiment #1**. The experimenters for Experiments #2 and #3 were A. Akpan, Dawn Fant, Marilyn Freeman, and Elvira Williams. The objectives, and substrate configuration in the deposition chamber for these experiments are shown below :

Experiment #2

Objective: The Purpose of this experiment was to obtain the following data:

- 1) Preliminary temperature profile using heat tapes
- 2) Replicate results of Experiment #1 with cleaned substrates
- 3) Obtain samples of DLC films for further analysis by test methods other than those currently available at N.C. A&TSU
- 4) Coat with DLC film a Cu/Cr coated ARDEC plate

Substrate Configuration in Chamber (See top of following page)

***Note:** Ms. Freeman handed out at this meeting a report entitled, "Thickness measurement of Diamond-like Thin Films on Silicon Wafers and Glass Substrates", which was performed by research team members at ARDEC on the DLC films deposited in Experiment #1. This report, in Appendix C, gives film thickness measurements of 3500 Å, 7000 Å, and 7400 Å.

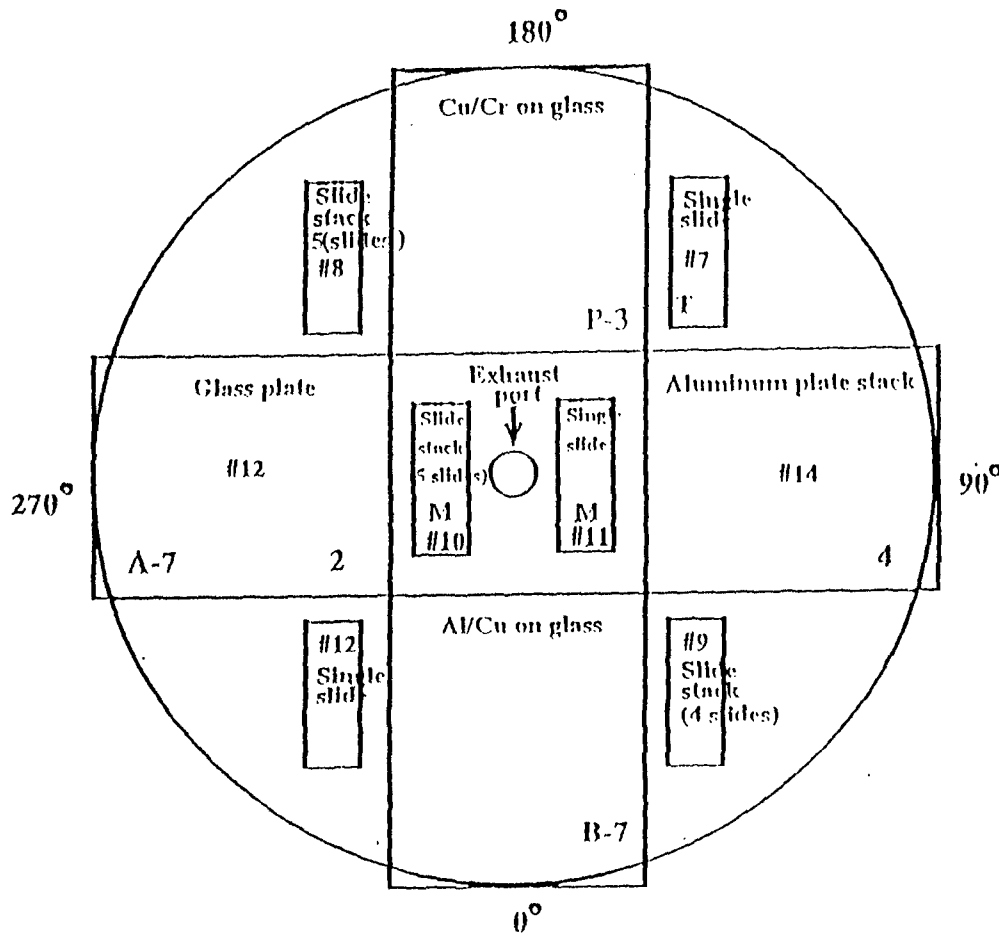

Note : (1) Heat tapes used were " CelsiStip " brand Type C, D, and E specially made for vacuums (Sprig/Switzerland). (2) Wafers were held on plate surfaces using small slip of 3M Scotch double-sided tape, (3) For the slides in the stack under slide #6 (See Chamber configuration sketch), a heat tape was placed on the bottom slide next to the platen: another on top of second slide up in the stack, another on top of the third and another on top of the top slide (4) "M" in sketch means mass of top slide was taken and "T" means a temperature tape, (5) Run time was 120 min., Rf power was 125W and substrate heights were all 7mm.

Experiment #3

Objective : To determine effects of raising Rf Power on quality and characteristics of carbon film (DLC) on various substrates.

Procedure: Substrates were cleaned using the same procedures as in Experiment 2. (Stacking slides and Al plates below the one substrate to be coated were not recleaned and heat tapes from previous runs were left in place since they had not changed during previous run). Substrates were placed in the same configuration in the chamber as in Experiment #2 and the same set of surfaces (Al, Si, Glass, Cu) were used. Efforts to replicate all deposition parameters of Experiment 2 were made except that Rf power for this run was to be increased to 175W. However, 175W was not achieved, so we ran at 155W.

Substrate Configuration in Chamber (See below):

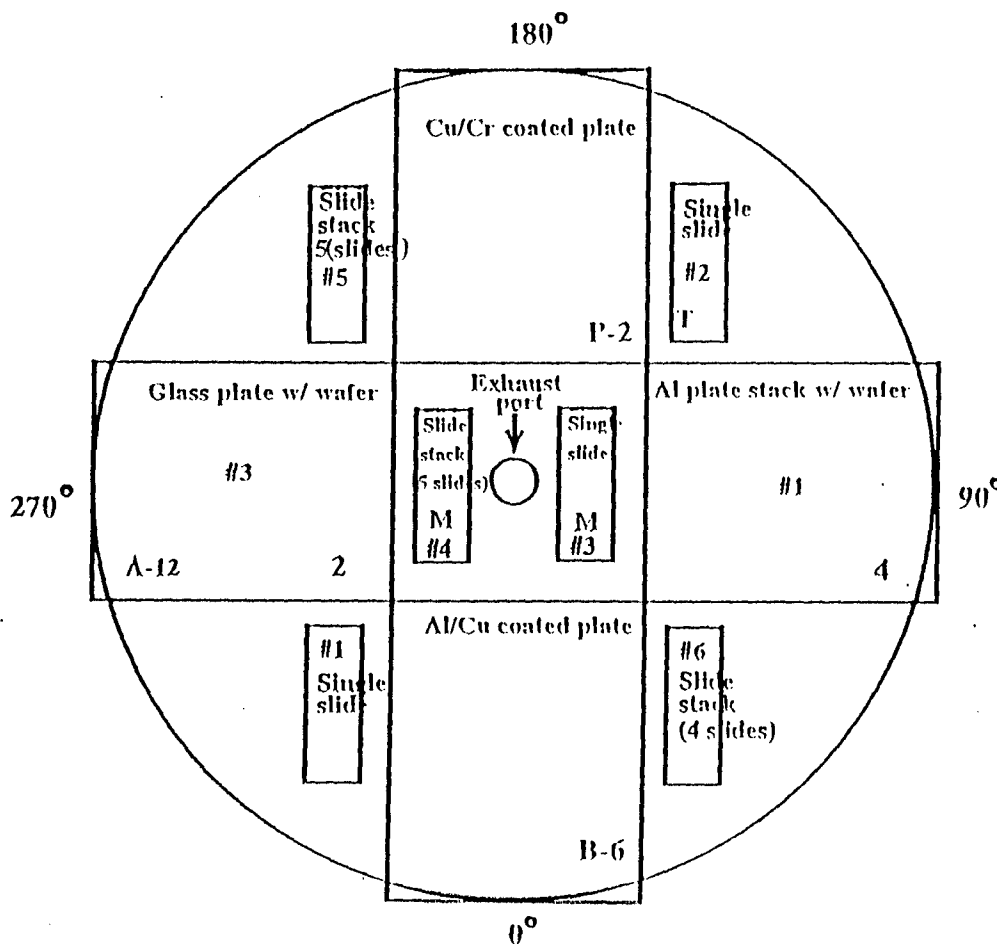

C. Analysis of DLC Films to Date:

The primary focus of these experiments was to determine the effect of both power and position of the substrate in the deposition chamber upon the deposition rate and composition of the DLC films. This section summarizes the results of the deposition chamber characterization experiments and preliminary analysis of runs made using ARDEC deposition plates. The deposition rate is reported using a normalized deposition rate (NDR) and the changes in composition are reported using FTIR data.

1. Normalized Deposition Rate (NDR)

As described in a previous section the mass of each wafer was measure before and after deposition. Because of the differences in the diameter of the wafers and the deposition times used these results are reported using a calculated normalized deposition rate (NDR). The NDR permits comparisons between different runs and the formula is given below:

$$\text{NDR} = \frac{\text{mass}}{\text{area} \cdot \text{time}}$$

Tables C-1 to C-3 show the NDR for depositions at different heights (z-direction) in the chamber and different deposition powers. A description of the positioning of the wafers can be found in section B.

Table C-1 shows the NDR for a substrate height of 0 mm in the chamber using both 30 and 120 watts. This corresponds to the silicon substrate resting directly on the base plate. The run number gives the actual run number and the x,y position of the wafer in the chamber. For example # 350-0 corresponds to run 350 at x,y position = 0°. Most of the runs were taken at X,Y = 0. Two runs (#339 & #307) were made with four wafers in the chamber at four different x,y positions (see section B for details) at 35 watts. Run #370 was run under the same conditions at 120 watts.

The average NDR at Z=0mm and 35 watts power was measured to be 3.9(0.2)E-06 mg/mm²-min. NDR values for

Table C-1
Normalized Deposition Rate for Z=0

RUN #	Diameter (mm)	Rf (watts)	Time (min)	Mass (mg)	NDR (mg/mm ² min)
339-0	101.6	35	360	11.05	4.0E-06
339-90	101.6	35	360	11.44	3.9E-06
339-180	101.6	35	360	11.69	4.0E-06
339-270	101.6	35	360	12.2	4.2E-06
307-0	101.6	35	180	4.89	3.8E-06
307-90	101.6	35	180	5.92	4.1E-06
307-180	101.6	35	180	5.32	3.6E-06
307-270	101.6	35	180	5.3	3.6E-06
				avg. =	3.8(0.5)E-06
370-0	101.6	120	168	9.74	7.2E-06
370-90	101.6	120	168	9.34	6.9E-06
370-180	101.6	120	168	9.58	7.0E-06
370-270	101.6	120	168	9.26	6.8E-06
				avg=	7.0(16)E-06

#339 have very little variation. While #307 NDR appears to vary with x,y position. The NDR at 120 watts was $7.0(0.2)E-06$ and corresponds to a 84% increase in the NDR at the higher powers.

Table C-2 shows the NDR for a substrate height of 7mm in the chamber at 30 and 125 watts. For 30 watts the NDR decreased with an increase in height to a value of $2.6(0.6)E-06$. There was also a decrease in NDR at 120 watts with the increased height to a value of $4.1(1.4)E-06$. Which is an increase of 58% compared to 30 watts.

Table C-3 shows the NDR for a height of 14mm in the chamber at 30 and 120 watts. The NDR decreased for both powers at this height. At 30 watts the NDR decreased to $1.0(0.1)E-06$, while at 120 watts the NDR decreased to $2.7(0.2)E-06$.

Figure C-1 is a graph of NDR vs deposition height and power. For both powers, NDR decreases linearly as the chamber height increases. The higher power clearly has a

Table C-2

Normalized Deposition Rate for Z=7 mm

RUN #	Diameter (mm)	Rf (watts)	Time (min)	Mass (mg)	NDR (mg/mm ² min)
364-0	101.6	30	180	2.63	2.7E-06
364-90	101.6	30	180	2.8	2.9E-06
364-180	101.6	30	180	2.7	2.8E-06
364-270	101.6	30	180	2.85	2.9E-06
				avg =	2.6(0.6)E-06
331-0	101.6	125	60	2.07	4.3E-06
331-90	101.6	125	60	2.33	4.8E-06
331-180	101.6	125	60	2.29	4.7E-06
331-270	101.6	125	60	2.44	5.0E-06
				AVG. =	4.1(1.4) E-06

Table C-3

Normalized Deposition Rate for Z=14 mm

RUN #	Diameter (mm)	Rf (watts)	Time (min)	Mass (mg)	NDR (mg/mm ² min)
376-0	101.6	30	180	1.53	1.0E-06
376-90	101.6	30	180	1.67	1.1E-06
376-180	101.6	30	180	1.46	1.0E-06
376-270	101.6	30	180	1.42	9.7E-07
				AVG =	1.0(0.1)E-6
375-0	101.6	120	180	3.55	2.4E-06
375-90	101.6	120	180	4.13	2.8E-06
375-180	101.6	120	180	4.11	2.8E-06
375-270	101.6	120	180	4.27	2.9E-06
				avg. =	2.7(2) E-06

faster deposition rate. This dependence on power and height does not imply that the same composition material is being deposited at the various heights. This will be discussed in the next section.

Figure C-2 shows the relationship between NDR and power for different substrates and higher powers at a chamber height of 7 mm. This graph combines data reported above with results obtained from experiments conducted with Ms. Marilyn Freeman. The experimental details of these runs were discussed in section B. The open symbols represent results obtained from depositions on insulating silicon containing substrates. The closed symbols represent metal films deposited on glass 7mm substrates.

The open inverted and upright triangles are the results for deposition on either glass slides or Si wafers on glass supports. For these completely insulating substrates the NDR clearly increases linearly with increasing power.

Figure C-1

Normalized Deposition Rate vs Power and Height

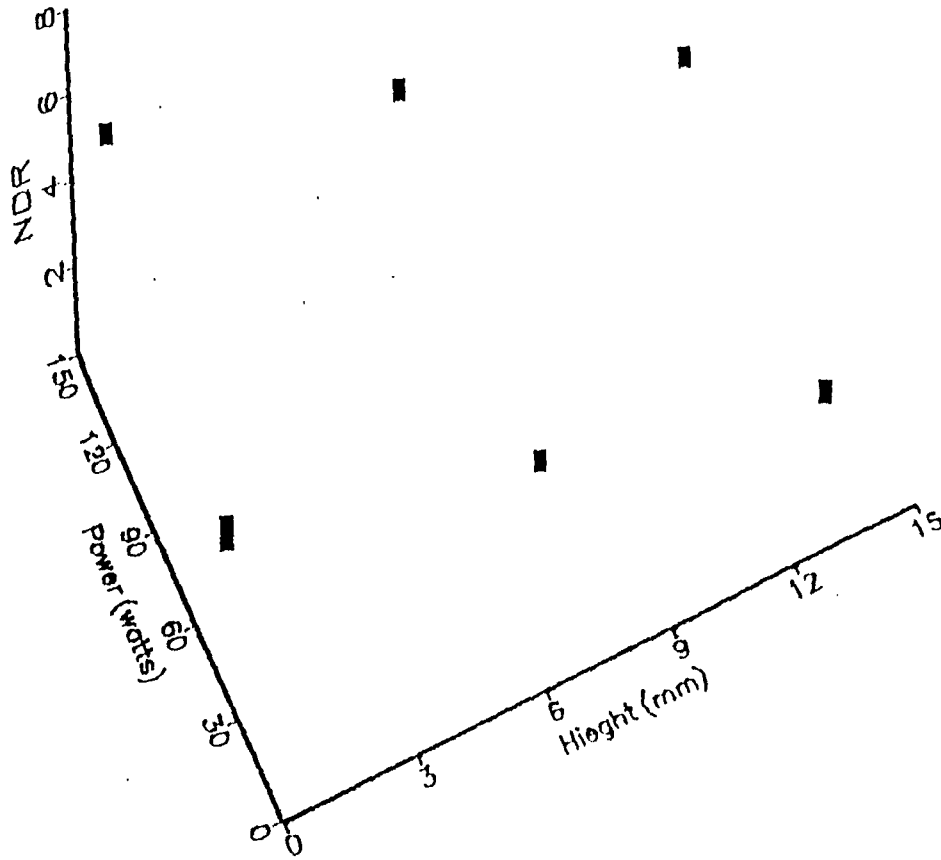

The open diamonds are the results of Si wafers on Al supports. At 120 watts the NDR is nearly the same as 30 watts. But there is a steep increase when the power is increased to 155 watts. At this power the deposition on the Si wafer is greater than the corresponding depositions on insulating supports. And nearly as large as the depositions on the metal thin films.

The closed circles and squares are the results of depositions on thin films of Al and Cu (respectively) deposited on 7mm glass substrates. At 120 watts there is clearly a larger deposition rate for these substrates than the Si containing materials. At 150 watts the change in NDR is not as large as the Si containing substrates. Which suggest very little dependence for the substrates upon power levels above 120 watts.

2. Analysis of Deposition Composition

Each FTIR run consisted of four wafers positioned around the chamber at a fixed chamber height (Z). FTIR scans (128

Appendix G
Experiments #4

Experiment #4

Objective: To determine the effects of grounding the metal substrates on the quality and characteristics of deposited carbon films (DLC)

Procedure: Substrates were metal-on-glass (2 Cu on glass, 2 Al on glass). Prior to cleaning, aluminum foil leads were attached to the tabs of one Al plate and one Cu plate using small pieces of Archer brand (64-010) tape solder (purchased at Radio Shack) and applying heat to the top side of the foil with a soldering iron. Plates were then rinsed in tap water and vapor cleaned in acetone vapor.

Substrate Chamber Configuration:

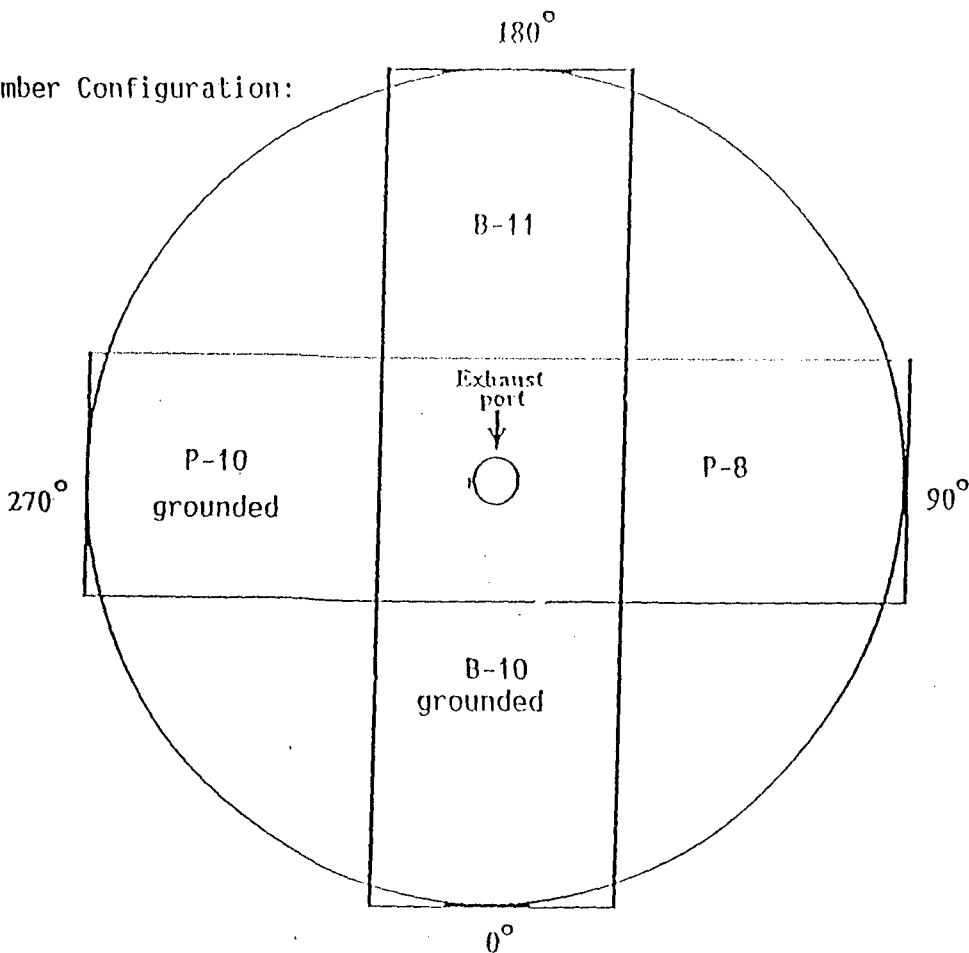

Appendix H
Experiments #5 and #6

Experiment #5

Objective: To obtain thicker films than those previously deposited on Al-on-glass plates and to make capacitor devices out of them for evaluation.

Procedure: Substrates were aluminum-on-glass (reliability plates). Plates were cleaned by rinsing with tap water and dried in acetone vapors. Plates were weighed, heat tape (cut) were applied as masked over the tabs (to prebase Al for later lead attachment), and plates were placed in the chamber as shown in the diagram below.

Experiment #6

Objective: To obtain thicker films than those previously deposited on al-on-glass plates and to make capacitor devices out of them for evaluation.

Procedure: 3 substrates were al-on-glass (reliability plates). 1 substrate was Al_2O_3 on Al-on-glass (reliability plates). All were cleaned by rinsing with tap water and dried in acetone vapors. Plates were weighed, heat tape (cut) mashed over tabs and placed into a clean chamber as shown in the diagram below.

Appendix I
Planned Technical Accomplishments Section
of July 26, 1994 Quarterly Report

The next phase of this design is the star or composite design. If there appears to be a lack of agreement between the average responses of the center point or non linearity, four star points are taken together. These points along with the factors are equidistant from the center points. These new runs are then randomized and the important effects and interactions can be determined by a linear regression.

From this information a response curve, which is a three-dimensional curve that plots the response against the factors, is plotted. This curve should span some range and thus indicates the areas of maximum and minimum experimental parameters.

II. PLANNED TECHNICAL ACCOMPLISHMENTS

The following are planned technical accomplishments to be conducted by the A&T* segment of the A&T - IAT/ARDEC research team that were generated during the July 11-13, 1994 Technical Meeting at A&T:

- (1) After the new flow meters are installed, the A&T segment of the research team will redo Experiment # 5 (see Appendix 2 for the objective and procedure of Experiment # 5) making any adjustments necessary to correlate the flow rates

*NOTE: Other parts of the joint experiments will be carried out by team members at IAT and ARDEC

(2) The A&T segment of the research team will correlate readings of the old flow controllers on the deposition system and the newly-ordered flow meters.

DLC films needed in Experiment # 6 (see statement of Experiment # 6 and its purpose in Appendix 2). The substrates will be 12 glass plates on which aluminum 1% copper (Al/1% Cu) films have been deposited by a standardized physical vapor deposition process utilizing resistance heating. The metal film layer will be nominally 2 microns thick and shall be examined prior to DLC deposition to ensure superior adhesion of the Al/1% Cu to the glass (samples tested should exhibit adhesions greater than 10,000 psi as measured by the Sebastian III adherence tester.)

All of the substrates will be coated with a DLC film using the PECVD technique at A&T. The deposition parameters are to be identical except for the time of run, i. e. thickness of the deposits will be the experimental variable. Since the deposition system at A&T can only accept four of the substrates in one run (due to the physical size of the deposition chamber), three runs will be required to coat the 12 substrates; therefore, three different DLC thicknesses will be produced.

(3) The A&T segment of the research team will make the DLC films needed in Experiment # 7 (see statement of Experiment

#7 and its purpose in Appendix 2). The substrates will be 12 glass plates supplied by ARDEC on which aluminum 1% copper (Al/1%Cu) films are deposited by a standardized physical vapor deposition process utilizing resistance heating. The metal film layer will be nominally 2 microns thick and shall be examined prior to DLC deposition to ensure superior adhesion of the Al/1%Cu to the glass (samples tested should exhibit adhesions greater than 10,000 psi as measured by the Sebastian III adherence tester.) Nine of these plates will be anodized under a standardized process so that an Al_2O_3 layer of nominal thickness of about 0.3 microns is formed.

All 12 of the substrates will be coated with a DLC film using the PECVD technique at A&T in which the deposition parameters are identical except for the time of the run, i. e. thickness of the deposits will be the experimental variable. Since the deposition system utilized at A&T can only accept four of the substrates in one run (due to the physical size of the deposition chamber), three runs will be required to coat the 12 substrates; one Al-on-glass plate with three Al/ Al_2O_3 -on-glass plates will comprise each run. Three different DLC thicknesses will be produced.

APPENDICES

MASS FLOWMETER
 CONVERSION FACTORS

GAS	SYMBOL	CALIBRATION DIAL SETTING
Acetylene	C_2H_2	.61
Air	—	1.00
Ammonia	NH_3	.68
Argon	A	1.44
Arsine	AsH_3	.66
Boron Trichloride	BCl_3	.39
Boron Trifluoride	BF_3	.61
Carbon Dioxide	CO_2	.74
Carbon Monoxide	CO	1.00
Chlorine	Cl_2	.84
Diborane	B_2H_6	.44
Dichlorosilane	SiH_2Cl_2	.44
Dichloro Methyl Silane	$(CH_3)_2SiCl_2$.23
Ethane	C_2H_6	.49
Ethylene	C_2H_4	.60
Freon-12	CCl_2F_2	.32
Freon-14	CF_4	.42
Freon-22	$CHClF_2$.44
Germane	GeH_4	.60
Helium*	He	1.43
Hydrogen*	H_2	1.02
Hydrogen Bromide	HBr	1.04
Hydrogen Chloride	HCl	.98
Hydrogen Fluoride	HF	1.00
Hydrogen Selenide	H_2Se	.81
Hydrogen Sulfide	H_2S	.79
Krypton	Kr	1.49
Methane	CH_4	.72
Methanol	CH_3OH	.58
Methyl Trichlorosilane	$(CH_3)_3SiCl$.25
Nitric Oxide	NO	.99
Nitrogen	N_2	1.00
Nitrogen Dioxide	NO_2	.41
Nitrous Oxide	N_2O	.73
Oxygen	O_2	1.00
Phosphine	PH_3	.69
Propane	C_3H_8	.36
Propylene	C_3H_6	.41
Silane	SiH_4	.59
Silicon Tetrachloride	$SiCl_4$.29
Sulfur Dioxide	SO_2	.66
Sulfur Hexafluoride	SF_6	.28
Tungsten Hexafluoride	WF_6	.22
Xenon	Xe	1.36
Trichlorosilane	$SiHCl_3$.35

Appendix 2: Some Details of Experiments #5, #6 and #7.

Experiment #5

Objective: To obtain thicker films than those previously deposited on Al-on-glass plates and to make capacitor devices out of them for evaluation.

Procedure: Substrates were aluminum-on-glass (reliability plates). Plates were cleaned by rinsing with tap water and dried in acetone vapors. Plates were weighed, heat tape (cut) were applied as masked over the tabs (to prebase Al for later lead attachment).

Experiment #6

Description:

Determination of the effect of thickness on dielectric strength (breakdown voltage) for DLC films produced by PECVD.

Purpose: To determine how breakdown voltage of parallel plate capacitors fabricated with PECVD DLC films varies with dielectric thickness.

Experiment # 7

Description:

Determination of the effect of a layered composite dielectric and layer thickness of dielectric strength (breakdown voltage) and DC leakage current for DLC films produced by PECVD in a layered Al_2O_3 /DLC dielectric system.

Purpose: 1) To determine the effect of a layered composite dielectric system comprising a thin film of Al_2O_3 under a DLC film on the DC leakage current and breakdown voltage of parallel plate capacitors.

2) To determine how breakdown voltage of parallel plate capacitors fabricated with layered composite dielectric comprised of a thin film of Al_2O_3 under PECVD DLC thin films varies with DLC thickness.