

JPRS-JST-90-035

27 JULY 1990

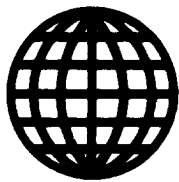

**FOREIGN
BROADCAST
INFORMATION
SERVICE**

JPRS Report

Science & Technology

Japan

27TH AIRCRAFT SYMPOSIUM

DISTRIBUTION STATEMENT A

**Approved for public release;
Distribution Unlimited**

REPRODUCED BY
U.S. DEPARTMENT OF COMMERCE
NATIONAL TECHNICAL INFORMATION SERVICE
SPRINGFIELD, VA. 22161

19980203 308

DIC QUALITY INSPECTED 3

SCIENCE & TECHNOLOGY

JAPAN

27TH AIRCRAFT SYMPOSIUM

906C3828 Tokyo HIKOKI SHINPOJIUMU in Japanese Oct 89 pp 1-63

[Selected papers on space plane development presented at the
27th Aircraft Symposium held Oct 1989 in Tokyo]

CONTENTS

Space Plane Flight Features, Motion Equation, Motion Mode [Kan'ichiro Kato].....	1
Winged Flying Object Plan [Jyun'ichiro Kawaguchi, Yoshibumi Inaya].....	7
Concept, Goals of Space Plane [Masataka Maita, Yoshiaki Ohkami, et al.].....	14
Objectives, Mission, Specifications for HOPE [Tetsuji Narasaki, Hiroshi Miyama].....	20
Aerodynamic Requirements for HOPE [Toshio Akimoto, Tetsuichi Ito, et al.].....	27
Aerodynamic Numerical Simulation of HOPE [Shigeaki Nomura, Yukimitsu Yamamoto, et al.].....	32
Heat Resisting Structure of HOPE [Masataka Yamamoto, Tadashi Matsumoto, et al.].....	40

Guidance Control Technology for HOPE
[Etsusada Takizawa, Hitoshi Mineno, et al.]..... 47

Rendezvous/Docking Technology for HOPE
[Yasushi Wakabayashi, Hiroyuki Nakamura, et al.]..... 57

Current Status, Role of Flight Simulation Technology
[Hirokazu Matsushima]..... 67

Space Plane Flight Features, Motion Equation, Motion Mode

906C3828A Tokyo HIKOKI SHINPOJIUMU in Japanese Oct 89 pp 14-17

[Article by Kan'ichiro Kato, Engineering Dept., Tokyo University:
"Aerodynamics of Space Plane"]

[Text] 1. Introduction

I publicized up-to-date study results (see reference) about space plane aerodynamics and its optimum routing. Dramatically different from conventional aircraft, the space plane flies at a very high speed at an ultra-high altitude where air is very thin. This kind of flight poses many problems not understood in conventional aerodynamics.

2. Flight Features

The flight range of a space plane is considerably greater than that of conventional aircraft. For example, in terms of the speed and altitude range, conventional aircraft fly at an altitude of 30,000 meters at about Mach 4 at most, but space planes are capable of flying several hundred kilometers high at as much as Mach 30. Of course, space planes do not need to fly in such a manner during all of their flights. For example, flying to and from space, the combination of flight speed and altitude is similar to that of an artificial satellite or space shuttle returning to earth.

When the United States announced a space plane plan a few years ago, the possibility of using the space plane for commercial flight was mentioned and its service was dubbed the "New Orient Express" by the newspapers. However, most countries are now very pessimistic about the commercial feasibility of space planes in view of their prohibitive cost. At present, interest in a space plane is as a research or experimental plane.

The combination of speed and altitude of a space plane is very roughly, as shown in examples of the U.S. NASP, a flight with constant dynamic pressure. Of course, when a space plane arrives at a satellite orbit, flight altitude increases at a constant rate at the end of its flight. Therefore, that portion does not undergo a constant dynamic pressure. In terms of flight to and return from a satellite orbit and in a cruising like an airplane, the

combination of speed and altitude is very much like a flight with constant dynamic pressure.

For example, a conventional aircraft, such as a modern jetliner, flies at Mach 0.8 at approximately 100,000 meters altitude. For a space plane flying at 50 kilometers (km) altitude, its speed will be about Mach 25, or 30 times higher than the jetliner.

At this altitude, air density is about one-thousandths of that at the ground surface. When dynamic pressures are compared, a flight at the altitude at 50 km is 30^2 in terms of the speed and $1/1,000$ in terms of the air density. The product of both is 0.9, or almost constant dynamic pressure.

This occurs for two reasons. First, the generation of flutters has a strong relationship to the extent of dynamic pressure. To eliminate flutters, flight speed tends to be limited during constant dynamic pressure. Second, air resistance is proportional to dynamic pressure. An air-suction-type engine increases its propulsion almost proportionate to its dynamic pressure. When an airplane with this type of engine flies at constant dynamic pressure, the balance between propulsion and resistance are adequate and additional redundant weight to reinforce strength is unnecessary because propulsion and resistance remain almost constant over a wide range of speeds.

The striking feature of a space plane flying like this is its enormous speed in a space with extremely thin air density. This results in three flight features.

First, heat is generated by its ultra-high altitude flight. When the airframe is reasonably round, the radiant parallel temperature is proportional to the square root of air density and the cube of speed. A flight with constant dynamic pressure increases the aerodynamic heating rate gradually as speed increases.

For the flight control of a space plane, the constraint of flying within a limit of aerodynamic heating rate plays an important role.

Second, because of its flight over the round earth at ultra-high speed, the centrifugal force as measured from the flying object becomes approximately same with as dynamic lift. For example, a flight at 5.5 km per second at 50 km altitude results in almost equal centrifugal force and lift. That is, the weight of crew becomes about half and the wings of space plane need to support just half of the weight.

Third, the ultra-high speed flow is approximated to Newtonian flow, and, as a result, its dynamic characteristics become drastically different from those of conventional flights. Generally, lift inclination decreases as the number of a flight Mach increases. In the hypersonic area, lift inclination becomes smaller by one digit (one-tenth) than lift inclination in the sub-hypersonic area. The dimensionless miniature coefficients, such as the static stability, angular speed attenuation and rudder steering, become smaller by one-tenth. Dynamic stability and rudder steering intrinsic to an airplane

become smaller by same degree when dynamic pressure is assumed to be almost constant.

3. Motion Equation

To analyze the flight route of a space plane, it is necessary to regard the earth as a sphere. For that purpose, it is convenient to use a polar coordinate. When a space plane is handled as a material point, six parameters--three positional coordinate variables (latitude, longitude, and altitude) and three motion coordinate variables (speed, route angle, and azimuth)--requiring six differential equations, are needed. In addition, when analyzing the motion as a fuselage, three integrating equations on moment are also needed. In that case, it is convenient to use linear-approximated dimensionless moment coefficients for three angular speeds and 2 speeds (angle of elevation and side slip).

For the six differential equations denoting routes, there are roughly two expressions. The first expresses speed and force in dimensions. For air density, a model that decrements logarithmically usually against altitudes is used. This is equivalent to rewriting a differential equation described in the third dimensional orthogonal coordinate used for conventional airplanes to a polar coordinate. It is useful when air density change is great, such as in lifting or returning home.

Another typical expression of the motion equation is the so-called improved Chapman parameter. A relationship described in a one-stage differential equation is assumed between air density and geocentric altitude. Then, some approximations are used and the air density component is removed from the motion equation. The improved Chapman parameter is expressed in Z and u . Z is roughly a variable related to air density (or altitude) and u is equivalent to a square of the speed made dimensionless with its altitude circular speed. The independent variable becomes a dimensionless arc (arc length).

In either of the motion equations, the aerodynamic characteristics of a space plane are approximated to C_L and C_D curves only.

However, when an improved Chapman variable is used, C_L is normalized with a $C_{L_{max}}$, giving the maximum lift and drag ratio. As a result, the aerodynamic characteristics expressed in the motion equation become a maximum lift and drag ratio in appearance only.

A motion equation using the improved Chapman variable is useful when an analysis is made or when altitude change (that is, density change) is small. When altitude change is large, Z (including density) is differentiated as a status variable, and its numerical value does not necessarily give a good result.

4. Motion Mode

Conventional aircraft have five modes--longitudinal short cycle, longitudinal long cycle, dutch roll, roll, and spiral. In the upper atmosphere, space planes exhibit all the modes except the longitudinal long cycle. However, the strength of stability and attenuation components are about one-tenth that of conventional aircraft, as mentioned earlier. Therefore, the attenuation component and natural frequency are far smaller values compared with ordinary aircraft.

A long-cycle motion is also generated for space planes. This is similar to that of conventional aircraft but the reason for its generation is different. In the upper atmosphere, air density lessens by about one-tenth each time altitude increases 16.5 km. The long-cycle motion generated in space planes is due to the effect of this density change.

If the route angle of an aircraft increases for some reason, its flight altitude soars. As a result, air density decreases and lift drops. The airplane starts to plummet below its initial altitude. Density then surges suddenly and lift increases to raise altitude again. The long-cycle motion generated in this way looks like the long-cycle mode for conventional aircraft. This oscillation for a shuttle plane takes about 200 seconds.

The motion of a space plane in the upper atmosphere includes a divergency mode, which does not exist for conventional aircraft (this mode is neutral for conventional airplanes). For conventional aircraft, route angle becomes an altitude when it is integrated. An intrinsic value (neutral root) equivalent to this integration becomes an unstable root for space planes.

When a space plane is supposed to be flying at a specified altitude and its speed is increased for any reason, centrifugal force and the radius of its circular motion increase slightly. Resistance decreases as air density decreases significantly. When propulsion is held constant, speed increases proportionate to the decrease of air and centrifugal force increases. As a result, the orbit bulges further.

Thus, the balance of a space plane flying on a circular orbit is not stabilized statically. Once speed increases, speed keeps increasing and the route bulges. In contrast, when speed decreases for any reason, speed keeps decreasing and altitude keeps lowering. This instability is not drastic, but it is unique to a flight in the upper atmosphere and has not been observed in conventional aircraft.

The two modes just mentioned are generated because air density change (though limited) varies suddenly (exponentially) in the altitude direction.

5. Optimization of the Flight Route

We have developed a formula for lifting, cruising, returning, and trajectory alteration (AOTV) as the optimum control problem and obtained its value solution.

The motion equation must be selected properly for each problem. For example, in the case of lifting and returning with considerable air density change, nondimensionless motion equations gave better results. Use of the Chapman variables at high density Z , including density, is differentiated as a status variable without giving good results.

In the case of lifting, not only air density but speed changes drastically. Better results were obtained by using horizontal and vertical speeds rather than flight speed and route angle as status variables.

In analyzing motion mode and AOTV optimization, good results were obtained by using a motion equation with the Chapman variables because the altitude change is relatively small. For the lifting problem, it is important to define engine performance reasonably; however, reliable engine data are not yet available.

From my own experience, acceleration in lifting increases considerably when an engine model now being proposed is used. Its satellite components are designed to sustain about 3.5 g's. Maximum propulsion had to be limited to optimize the route. Engine design is conducted independent of minimizing route at present, but I believe it is necessary to reflect the results from orbit analysis on the engine design in a reasonable manner.

In analyzing maneuver used in returning home or orbiting change, the limitations of load factor and aerodynamic heating affect flight route considerably. It is not yet clear which limitation is the most severe, but, from estimation of a curving of the orbit, aerodynamic heating may become the more severe limitation requirement. To relate aerodynamic heating to the optimization calculation strictly, it is necessary to analyze constraints of the quantity of state accurately.

Load factor change is proportional to dynamic pressure, and aerodynamic heating is proportional to the square root of air density and the cube of speed. In either case, air density and speed are related, but the speed of a space plane cannot be controlled suddenly. What can be widely observed from numerous calculations is that load and heating limitations are achieved mainly via air density change. That is, when limiting load factor and aerodynamic heating rate, many optimizing solutions are realized by adjusting flight altitude. In such cases, roll angle change is important in controlling flight altitude. Orbital face change using pneumatic force is equivalent to the turn of conventional airplane. However, orbital face change of a space plane is most effectively accomplished when it is used together with rocket injection. Orbital face change using pneumatic force is particularly effective when a space plane shifts to a lower orbit from a higher one. In this case, it is possible to save about half of the fuel (total including speed increase) compared with an orbital face change only with rocket injection.

For cruising, I developed a minimum fuel and shortest time formula. From such analyses, a typical flight profile is to soar high using fuel for a time

and then to skid like a bullet. This solution is optimal but is said to be economically unfeasible.

This kind of flight is not a steady state because its altitude and speed change always.

It is generally agreed that a cruising speed of about Mach 7 results in an economic hypersonic flight.

To fly at such a speed, a different type of engine is needed and it is necessary to set values for its specifications that differ from those of space shuttle engines. Design of a numerical model is also quite unsatisfactory at present. In the optimization calculation for cruising, an effect of the long-cycle mode appears, which is attributable to density change mentioned earlier. It is estimated that it is a result of oscillation, but it is difficult to obtain an accurate numerical solution in the cruising calculation.

6. Conclusion

The preceding results were obtained by assuming hypersonic characteristics for aerodynamic characteristics. Route optimization was calculated by assuming that characteristics do not depend on speed. In reality, characteristics should be varied, depending on a change of Mach. It also is necessary to consider this effect naturally for accurate further analysis.

It also is necessary to have an optimization calculation integrating cruising, lifting, and returning home. At present, we are calculating for optimization by separating them. However, it is still difficult to have numerical solutions from such a separation. It is estimated that it will be more difficult to have optimization solutions when such flight factors are integrated.

References

1. Kan'ichiro Kato: "Space Plane," Tokyo University Press, Sep 89.

Winged Flying Object Plan

906C3828B Tokyo HIKOKI SHINPOJIUMU in Japanese Oct 89 pp 18-21

[Article by Jyun'ichiro Kawaguchi and Yoshibumi Inaya (ISAS): "Winged Flying Object Plan of the Institute of Space and Astronautical Science"]

[Text] 1. Introduction

The Institute of Space and Astronautical Science organized a winged-flight object work group in 1982 to conduct basic development research on a future space transportation system. Its activities are ongoing and include effective use of methods needed in flight experiments of balloons and rockets possessed by the ISAS. The activities also include verifying basic research results by directly implementing flight experiments in preparation for a reusable space transportation system in the near future.

One important objective is to search for a suitable design for the space flying object for the Space Science Laboratory, with subsequent space development through these activities. This report describes initial research of a flight experiment using small flying objects.

2. Basic Development Research

2 - 1. System Research

The ISAS has investigated various flying object systems as targets for basic development research and in 1984 proposed a concept for the HIMES flying object (Highly Maneuverable Experimental Space Vehicle--Figure 1). This was proposed as an experimental vehicle for verifying technologies related to a full, reusable rocket flying object by matching the experimental plan with future plans for development of a liquid-oxide/liquid-hydrogen rocket promoted by the ISAS.

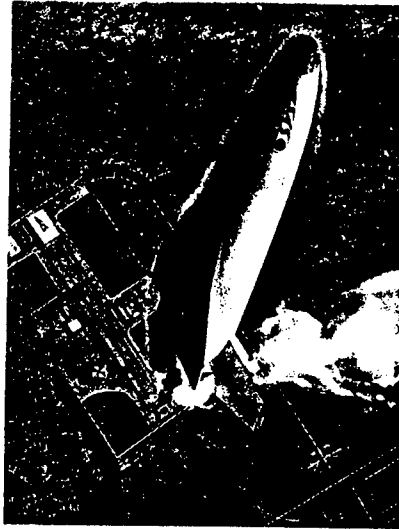

Figure 1. HIMES Flying Object

It is designed as a vehicle capable of bullet flight in the upper atmosphere, and its engineering objectives are aimed at technology related to:

- (1) Reusable rocket vehicles.
- (2) Aerodynamic, heat resistant flight control during atmospheric reentry.
- (3) Guidance and automatic landing of an unmanned flying vehicle.

The technologies needed to develop a flying vehicle are based primarily on those already developed and include an airframe system technology as a structural body, taking into account the heat resistance in reentering the atmosphere. Further, as an application, conducting scientific observation and a weightless experiment by making the most of observation rockets possessed by the ISAS was considered.

As a way of actualizing the HIMES flying vehicle, hardware mentioned earlier may be manufactured. Through its flight and blasting experiments, various technological elements will be clarified, test-produced, and verified as an activity policy of the ISAS. The following flight experiments are scheduled:

- (1) Skid flight experiment at low speed.
- (2) Atmospheric reentry experiments.
- (3) Flight experiments for guidance and automatic landing.

In addition, with the aim of use as a propulsion system loaded on an HIMES flying vehicle, the following is targeted as the next technological

development for the liquid-fuel rocket engine of the Space Science Laboratory:

(4) Development of a high-pressure expander cycle liquid-fuel rocket engine.

Development of these four components are the current tasks scheduled. Following is a description of some of the plans already put into practice.

2 - 2. Acquisition of Basic Technologies

We are investigating the general problems a lift flying vehicle reentering the atmosphere encounters and are conducting various activities to acquire experience needed for aerodynamic design of a HIMES flying vehicle and for small experimental planes.

We developed software design systems, acquired data through wind-tunnel experiments, and evaluated flight characteristics by concentrating particularly on aerodynamic designs that take into account the various aerodynamic problems involved in reentering the atmosphere at a large elevation angle. These experiments have had a direct impact on aerodynamic design and the flight system of experimental models.

Further, we conducted basic research on an inertial navigation guidance system for full-scale development of a guidance system to be used in the HIMES flight vehicle. We also manufactured test models of the mounting sensor and processor using system analysis, TDG, and an acceleration system. We also developed their software.

2 - 3. Thrust System

The engine development program of a liquid-oxygen/liquid-hydrogen rocket by the ISAS completed its initial development plan with completion of a stage combustion test for 10-ton-class rockets. As a next step, we have launched a program for a high-pressure expander cycle (HIPEX) provided with an in-house developed heat exchanger in its combustion unit to use in the first-stage rocket (Figure 2). Specifications for this engine have been determined as the main thrust system of the HIMES space vehicle described above. Subsequent to the basic development test related to the heat exchanger, we have conducted a test of an engine system with low-combustion inner pressure and verified that it has the specified capacity.

Further, we extended the liquid-hydrogen engine technology and conducted a basic R&D program for the air-turbo ram (ATR) jet engine, as well as basic research for an air suction engine needed in the future space transportation system. We then began development of a ground-based engine combustion test system. We also have a program for testing the capacity of model engines and for basic R&D of their air intake in the high-speed wind tunnel.

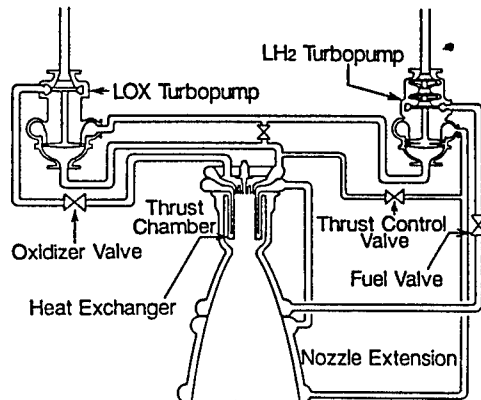

Figure 2. HIPEX Engine

2 - 4. Flight Experiment

2 - 4 - 1. Gliding Experiment

We have planned and conducted a flight experiment to acquire knowledge obtained through actual flights, because we consider it important to directly reflect results of basic research on the actual flight and promote its substantive study. After the inauguration of the Winged Space Vehicle Working Group, the gliding experiment was conducted in 1986 and 1987 (Figure 3) after a dynamic characteristics identification experiment of a small, radio-controlled space vehicle. The experiment was conducted to substantiate flight-control capacity at a low altitude by separating the space vehicle from a carrying helicopter at an altitude of 1,000 to 2,000 meters and piloting the vehicle automatically with a mounted control system. One of the experimental objectives was to establish a relatively simple experimental method in preparation for the forthcoming unmanned, landing guidance experiments.

Through the flight experiments of five test models, precious experience was obtained about aerodynamic flight control and guidance characteristics.

2 - 4 - 2. Reentry Experiment

A flight experiment succeeded the gliding experiment. We concentrated on substantiating flight characteristics during atmospheric reentry and investigated systems capable of conducting this kind of experiment at a comparatively low cost. Initially, it was proposed that a space vehicle be launched from the ground into the upper atmosphere using an observation rocket; however, this proved to be economically unfeasible. Many other ideas were proposed. We adopted and implemented a method to use a balloon and rocket combination for the reentry experiment.

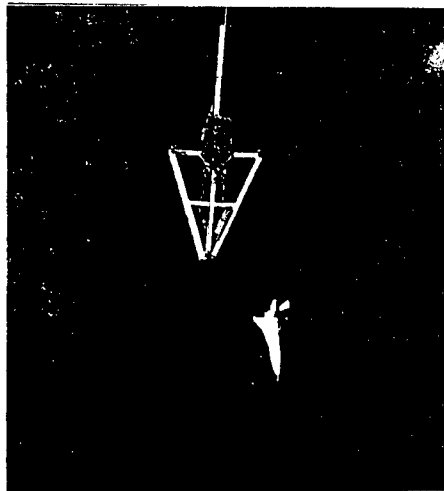

Figure 3. Gliding Experiment

In this experiment, we launched to an altitude of about 80 km a winged space vehicle having the two RCS attitude control functions and an aerodynamic rudder to conduct reentry to the atmosphere and high-speed gliding. We intentionally avoided a problem relating to aerodynamic heating and concentrated on aerodynamic performance and flight attitude during reentry.

The experiment was conducted by limiting the maximum Mach to about Mach 4. Following a confirmation test for balloons and separation of a space vehicle in the upper atmosphere in October 1987, we carried out the first flight experiment (Figure 4) in September 1988. An error generated in the balloon just before launching caused suspension of the experiment and jettison of the instruments. We are investigating the cause and developing countermeasures to prepare for resuming the experiment.

2 - 4 - 3. Landing Guidance Experiment

The landing guidance experiment is in the planning stages. We are discussing a development plan for the experiment system, together with an external navigation support system study, by using an unmanned, winged space vehicle for guiding and landing on the runway. We are making the most of basic research described earlier for gliding experiments and for a navigation guidance system. We are also considering the use of balloons to carry the space vehicle to the upper atmosphere.

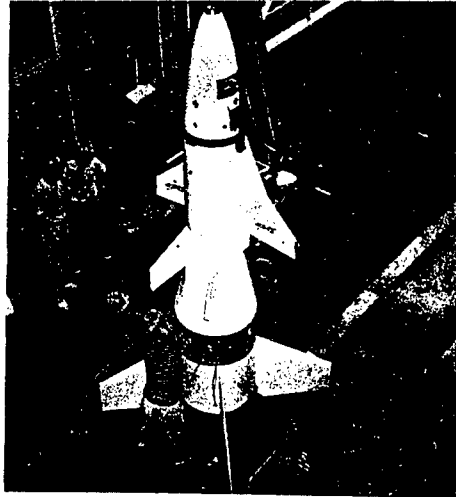

Figure 4. Atmospheric Reentry Experiment

3. Conclusion

We have outlined the present state of various R&D projects on a reusable, winged space transportation system proposed and implemented by the Space Science Laboratory. These programs are to be implemented in stages, with the realization of HIMES space vehicle proposed by the Space Science Laboratory as the mid-term development objective. At present, a so-called space plan is the target for transportation into space. Japan has little experience on flying vehicles using air positively (not only for hypersonic flight but also for supersonic flight), apart from rockets, and we believe it imperative that we acquire experience on such flights through various means. For that reason, it is important to promote development plans for experimental models proposed by related institutions and to accumulate basic data. We hope our programs are contributing to the realization of this target. The foregoing discussion outlines the many internal or external research activities of the Space Science Laboratory as summarized by the writers. See the references for representative research results.

References

1. Nagatomo, M., et al., "A Concept of HIMES Vehicle," 36th IAF, 1985.
2. Winged Space Vehicle Working Group: "HIMES Space Vehicle Program Outline," HIMES Space Vehicle Sub-committee, 1987.
3. Inatani, Y., "An Interactive Design System for Winged Space Vehicle," Transaction JSASS, Vol 31, No 94, Feb 1989.

4. Inatani, Y., "High Speed and High Angle of Attack Aerodynamic Characteristics of Winged Space Vehicle," ISAS Report No 624, 1987.
5. Yonemoto, K., et al., "Analytical Interpretation on the Lateral/Directional Stability and Controllability of High Angle-of-Attack Reentry Flight," ISAS Report No 630, 1988.
6. Naruo, Y., et al., "Development Study of LOX/LH2 High Pressure Expander Cycle Engine," JSTS, Vol 4, No 1, 1988.
7. Tanatsugu, N., et al., "Analytical Study of Space Plane Powered by Air-Turbo Ramjet With Intake Air Cooler," IAF-87-264, 1987.
8. Kawaguchi, J., et al., "On the Stability Derivative Identification via the Scaled-Down Model Free Flight Experiment of the Shuttle-Type Winged Vehicle," 14th ISTS, Tokyo, 1984.
9. Nagatomo, M., et al., "Low-Speed Glide Characteristics of Winged Space Vehicle," JSTS, Vol 4, No 2, 1988.
10. Inatani, Y., et al., "Preliminary Flight Test for Reentry Flight of Winged Space Vehicle," 16th ISTS, Sapporo, 1988.
11. Akiba, et al., "Winged Space Vehicle Reentry Experiment Plan," Space Transportation Symposium, 1987.
12. Kawaguchi, et al., "Flight Control System of Winged Space Vehicle Reentry Experiment Model and Its Flight Simulation Test," Space Science Laboratory Report No 64, 1989.

Concept, Goals of Space Plane

906C3828C Tokyo HIKOKI SHINPOJIUMU in Japanese Oct 89 pp 22-25

[Article by Masataka Maita, Yoshiaki Ohkami, and Takio Yamanaka of the Aerospace Technology Lab, Science and Technology Agency: "Concept of a Space Plane"]

[Text] The basic concept of a space plane for developing manned space activities and as manned transportation means to support the forthcoming space development and utilization (see references) has been discussed several times.

The goals of a next-generation space plane are safety, reliability, interchangeable operations, and reduced operational costs as a manned transportation means. We believe there are two different but complementary approaches to next-generation transportation. The first involves systematic design improvement and expanding development with an innovative system as its base by using new concepts and technology. The second is to use the H-II rocket, to be launched in early 1990s, as the base for launching unmanned freight transportation vehicles. It is important to implement a systematic R&D scenario for expanding the system with innovative technologies by maintaining the state of the art of Japan.

Keeping the foregoing basic requirements in mind, the concept of a space plane will be as follows:

- Utilization of the aerospace technical infrastructure, such as a redundant system in case of an engine trouble, an airplane-type control system, reduction of the thrust-loading ratio for use of wings (air), a flight-abort capacity, expansion of cross-range capacity, design criteria, and R&D process for the further improvement of safety and reliability.
- Utilization of an airplane-type operation (ground support facilities, constraints of an assembly tower for vertical launchings, and elimination of perishable components) for interchangeable operation, orbit-on-demand capacity, and reduction of the operating cost.

- Drastic reduction of the fuel fraction, especially the use of air as the thrust agent to reduce the oxidization agent, improvement of the thrust rate, and extension of the operation area.

- Drastic reduction of the structural weight with advanced materials and structural designs.

By concentrating on these important points, a configuration of newly developed technologies should be defined.³⁾

In the past, Goddard of the United States (in 1933) and Saenger of Germany (in 1956), among others, developed launch vehicles with air-breathing engine thrust systems--there are nothing new in the development itself. Many past developments centered on twin-stage to orbit (TSTO) and horizontal take-off and landing systems. This was because of its potential, an increase of the payload rate by staging, an air breathing engine activation at the development stage, capacity limit, lack of advanced materials, and weight reduction in structural designs (Figure 1).

The air-breathing engine as a thrust system is one of the largest factors to consider in determining the shape of a space plane. In particular, it is important to develop an engine with light weight, a high thrust rate, and a wide operational range to reduce the fuel fraction in the single-stage to orbit (SSTO) system³ (Figure 2). The following research on the thrust system and structural design is now being promoted.

- (i) Expansion of the activation limit of a scram jet engine;
- (ii) Engine connecting take-off to a scram operation range (LACE, ducted rocket, turbo system);
- (iii) Adoption of slush-hydrogen fuel.

The SCRUM/LACE engine is considered a promising target concept for the thrust system and researches for its related system have started to implement its R&D scenario (Figure 3).^{4),5),7)}

A time schedule is needed to develop the technology for a scram jet engine; improve to LACE based on the LE-7 engine to be developed for the H-II rocket; treat the integrated system from the foregoing as an intermediate, rocket-based manned vehicle; and implement the final SSTO system by integrating the scram engine. This should not be limited to a single concept in view of the uncertainty of technical developments--replaceable concepts should also be considered.

A definition study for this kind of space plane has been conducted in a system discussion using as reference a single-stage take-off-and-landing model (total weight of 350-ton class, four crews, mission weight of 2 tons, access of low orbit of 500 km).⁸⁾

Source	Date	No. stages	GTOW (ton)	Payload (ton)	Vehicle type	Engine type	Max ABE Mach no.
Goddard	1933	2	-	-	W	EF	-
Saenger	1956	2	2		HTO W	TJ, ERJ, RJ	
Ferri	1961	17,2,3	34-453	1.5-4.5		TJ, SCRJ	
Kappus	1961	2			HTO W	TJ, ATRock, ATE	
Wu	1961	3	136	4	W	RJ-SCRJ	13
Jamison (B. Sidd.)	1961	2	19-170	2.3	HTO W	TRJ, SCRJ	<14
Lane (B. Sidd.)	1962	2,3	4.5-226	0.8-4.5	HTO W	PCTJ, TRJ, LACEE...	<12
(Texaco Ex.)	1963	3	122	111	VTO	ATE	6
Bailey (Lockheed)	1964	3	317	3	HTO W	TRJ, LACEE	
Smith (BAC)	1965	3	227	53-107	HTO W	TRJ	4
Lombard (Rolls R.)	1965	2	45.4	0.23	HTO W	ATRock (JP4)	4.5
Finke	1965	2	112-162	4.5	HTO W	TJ, SCRJ	
Woodcock (NASA)	1965	2	362-680		HTO W	TRJ	<8
Peoples (Boeing)	1965	2,3	240-336	4.6-5.3	HTO W	TRJ	5.3
(Marquardt)	1966	1.2	453	<32	HTO W	EFRJ, LACE, SCRJ...	<12
Peterson (NASA)	1966	2	226	5.9	HTO W	TRJ	6
Dupin (Nord Av.)	1966	2	200	6	HTO W	TRJ (JP4)	4
Nudling (Boelknow)	1966	1,3	25-105	0.4-2.5	VTO	ERJ	4.5
Cooper (BAC)	1966	2	340	2.9	HTO W	ERJ	5
Nau (Convair)	1967	1,2	419-521	18.1	HTO W	TRJ, LACE, SCRJ	<12
Francis (H. Sidd.)	1967	2	220	12	HTO W	TRJ, EB, SCRJ	12
Dobrowolski (NASA)	1969	2		11.3	W	SCRJ (2nd stage)	<25
Goethert	1970	2	453	20	HTO W	SCRJ	
Gregory (NASA)	1970	2	508	15.4	HTO W	TRJ, SCRJ	10
Franciscus (NASA)	1972	2		23.6	W	SCRJ (2nd stage)	18
Knip (NASA)	1972	2,3	589	22.6	HTO W	TRJ (methane)	<8
Salkeld	1975	2	1188	31	HTO W	TRJ, SCRJ	<9
Beichel (Aerojet)	1975	1	2270	25	VTO W	ERJ	
Dipprey (NASA)	1976	2	952	27	HTO W	RJ, SCRJ	
Jackson (NASA)	1977	1/2	1180	29.5	HTO W	TJ (JP4)	3.5
Martin	1977	1	1030	<0	HTO W	EFRJ	4.4
Bell (Rockwell)	1978	1	5035	454	VTO	EB	
Reed (Rockwell)	1979	1	22780	89	HTO W	TRJ < ATE	6
Chase	1979	1,2	1049-1371	29	HTO W	TRJ, SCRJ	<10
Kramer	1979	1/2	155	12.1	VTO	ATRock, RJ	6.1
Cormier	1979	2	500	7.4	HTO W	TJ	0.8
Lantz	1982	2	985	32	HTO W	RJ, SCRJ	<25
Netterfield	1984	2	113	7	HTO W	EB	12
Barnard	1984	1	13	1.1	VTO W	ATRock, SCRJ	18
Cimino	1985	1	174	9	VTI W	ATRock, LACE, SCRJ	24
Escher	1985	1	<500	11	VTO	EFRJ, LACE, SCRJ	<20
Shoettle	1985	1	2106	50-61	HTO W	RJ	<8
Lo (DFVLR)	1985	2	402-437	7.5	H&VTO W	RJ	5.5
Parkinson (BAe)	1985	1	196-175	7	HTO W	PCTJ/LACE?	<6
Ashford	1986	2	181-500	2-4	HTO W	TJ	<4
Hartung	1986	1	159	9.1	HTO W	ATRock, SCRJ	20
Naftel (NASA)	1986	2,3	332-372	2.3	HTO W	TRJ	<5
(ESA)	1987	1,2	260-430	7	HTO W	ERJ, TRJ, ATRock...	<7
Koelle (MBB)	1987	1	300-350	5-15	HTO W	TRJ, ATRock	<6
Bouillet (CNES)	1987	2	250	7	HTO W	ATRock, TRJ	4.5
Tanatsugu (ISAS)	1987	2	360.5	15	HTO W	ATRock, ATE	6
Poth (Aerojet)	1987	1	450-800	4.5	VTO W	SCRJ	<17
Piland (NASP)	1987	1			HTO W	SCRJ	<25
Dorrington	1988	1	450		HTO W	ATRock, TRJ, RJ	5.3
Space Plane Coordination Council/NAL	1988	1	350		HTO W	SCRJ	<12

Key ; Horizontal takeoff HTO, Vertical takeoff VTO, Winged W, Air-turbo-exchanger ATE, Air-turbo-rocket ATRock, External burning EB, Ejector fan EF, Ejector ramjet ERJ, Liquid air cycle engine LACE, Precooled PC, Turbojet TJ, Turboramjet TRJ, Ramjet RJ, Supersonic Combustion SC.

Figure 1. Example of Air-Breezing Thrust Launch Vehicle Studies⁶⁾

Figure 2

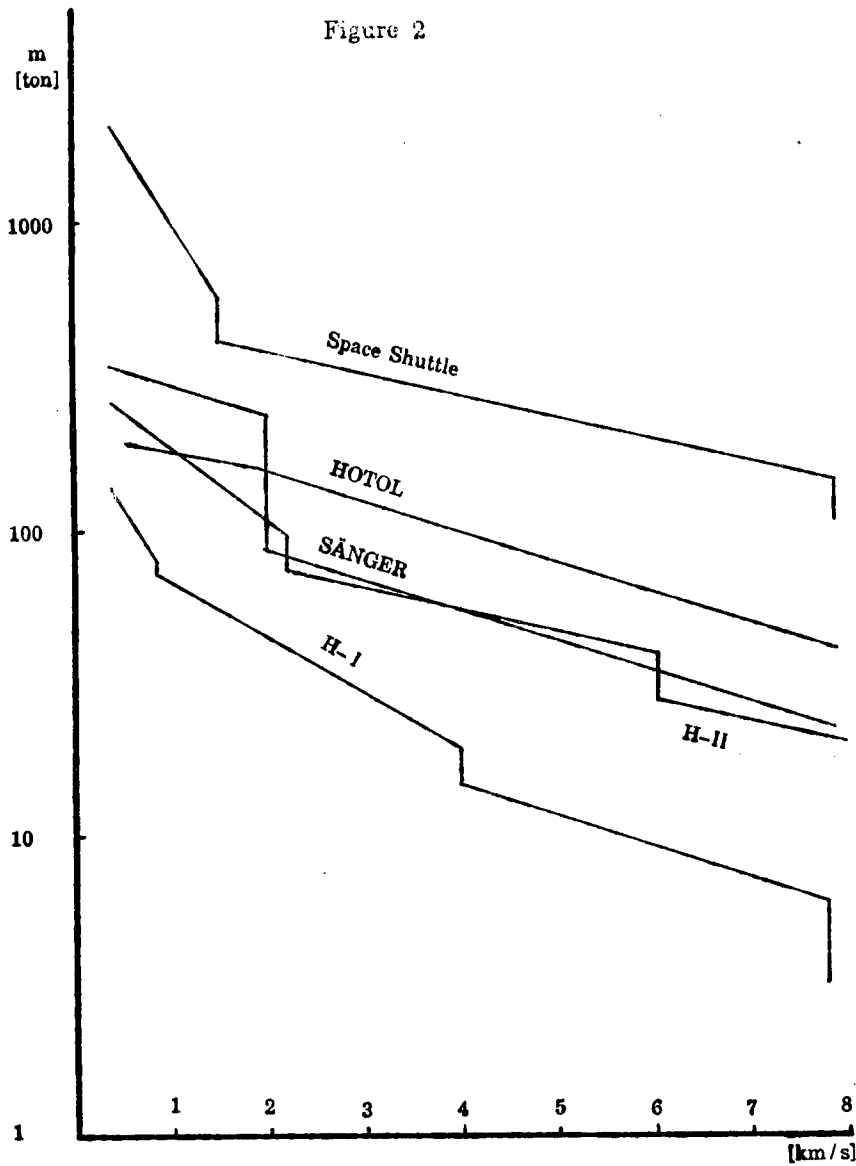

Space Shuttle	m	2041	670	SRB	310	141	ET	105	94.3	OMS-2 Stop
	v	0.41	1.54	Separation	1.54	7.82	Separation	7.82	7.74	
	h	0.0	47.3	Separation	47.3	118	Separation	118	280	
H-I	m	140	80	SOB	73.7	19.4	1st stage	14.5	5.9	2nd stage Separation
	v	0.4	0.86	Separation	0.86	4.0	Separation	4.0	7.8	
	h	0.09	20	Separation	20	104	Separation	104	186	
H-II	m	261	95.9	SRB	74	38.8	1st stage	27	19	2nd stage Combustion stop
	v	0.4	2.2	Separation	2.2	6.1	Separation	6.1	10.6	
	h	0	40	Separation	40	167	Separation	167	273	
HOTOL	m	196	LACE	162	Rocket	40				
	v	0.5		1.9		8.3				
	h	0		28		90				
SANGER	m	847	240	ERTV	87.7	22.2				Unit Mass m (Mg) Velocity v (km/s) Height h (km)
	v	0.41	2.0	Separation	2.0	7.9				
	h	0	31	Separation	31	85				

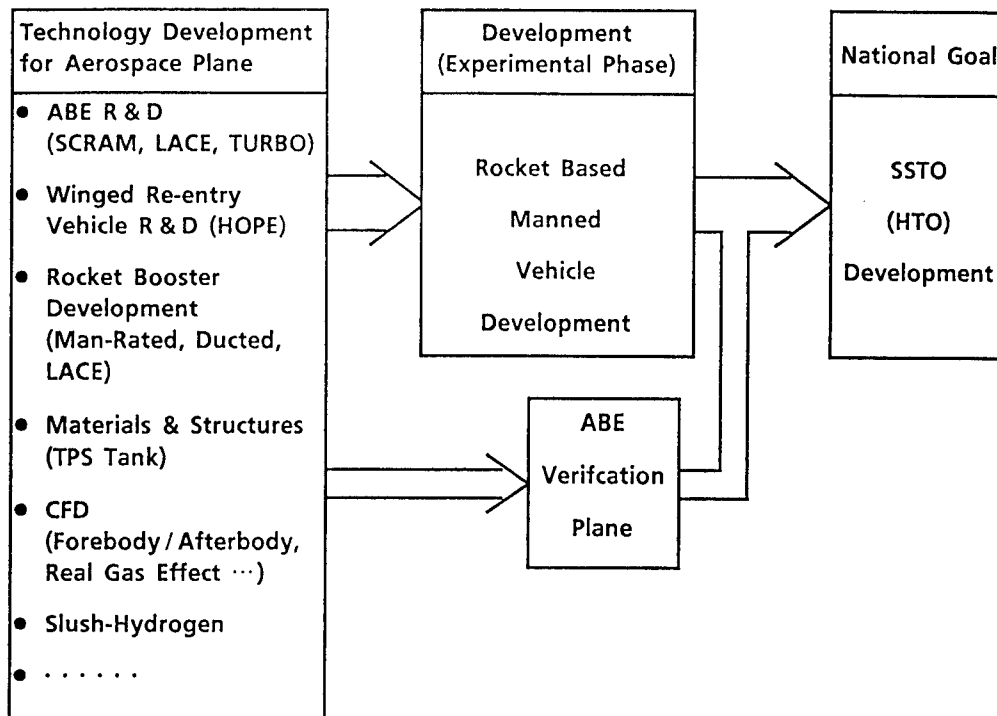

Figure 3. Manned Space Plane R&D Scenario

It is hoped a more concrete image for a space plane concept for Japan, with efforts of related institutions and Space Plane Coordinating Councils, as well as a prospect for promoting a full-scale R&D program, will be established.

References

1. Report on Space Plane Discussions, June 1987.
2. Kobayashi, S., Maita, M., et al., "Perspective on Japanese Space Plane R&D, Proc. of 1st International Conference on Hypersonic Flight in the 21st Century," September 1988.
3. Masataka Maita, "First-Generation Space Plane Transportation System of Japan," Japan Aerospace Society Journal, Vol 37, No 428, September 1989.
4. Yamanaka, T., "Space Plane Research Activities in Japan," AIAA Paper 89-5008, 1989.
5. Maita, M., et al., "Full Reusable SSTO Aerospace Plane Research and Development," International Journal of Cryogenic Energy, 1989.

6. After Dorrington, E., "Optimum Combined Cycle Propulsion Systems for Earth-to-Orbit Transportation," AIAA Paper 88-3073, 1988.
7. Report on Space Plane System Basic Concept Discussions, Aerospace Technology Lab/Mitsubishi Heavy Industry Inc., 1988.
8. Masataka Maita, et al., "Space Plane System Study," Japan Aerospace Society 26th Airplane Symposium, October 1988.

Objectives, Mission, Specifications for HOPE

906C3828D Tokyo HIKOKI SHINPOJIUMU in Japanese Oct 89 pp 36-39

[Article by Tetsuji Narasaki and Hiroshi Miyama of the National Space Development Agency: "HOPE Concept"]

[Text] 1. Introduction

In line with development of an international space station, it is time for Japanese space development to aim at activities in space using facilities on orbit. With this background, the space development policy guideline for the 1989 fiscal year laid out a future program for establishing its own technologies and international cooperation for manned space activities. The guideline called for participation in the space station program and promotion of basic technologies for a manned space shuttle (space plane).

The National Space Development Agency of Japan is now studying a winged shuttle (HOPE: H-II Orbiting Plane) to be launched by the H-II rocket. The mission of the winged shuttle is transportation of goods to the space station. Another objective is the development of technologies for a reusable space plane in the future.

The study of winged shuttle vehicles started in FY 1978, and we have promoted important studies needed for their development--such as heat protection, rendezvous, recovery guidance control, reentry aerodynamics, and aerodynamic heating approximation technologies. In FY 1985, we have launched a study on a space shuttle system with a view to implementing the space station program and, since FY 1987, we have been exercising a concept design for a 10-ton-class winged shuttle (HOPE) to be launched by the H-II rocket.

2. Objectives and Meaning of the Development

The development of the HOPE has two future objectives: (1) meeting needs for space shuttle transportation and (2) developing the main technologies for a winged space plane.

Materials for the Japanese Experiment Module (JEM) of the space station will be periodically supplied by a U.S. space shuttle.

However, if it is possible for Japan to maintain its own transportation and use the HOPE, based on the experiment schedule of Japan, it would result in more effective space experiments.

In addition, after development of the H-II rocket is completed, the technologies to launch a large-scale rocket from the ground will go international and emphasis will shift to a space plane.

Therefore, it is important to develop the HOPE as early as possible because it is a pre-stage vehicle for overall space plane development. The HOPE is an unmanned space shuttle that will be launched to low orbit from Tanegashima by the H-II rocket. It will conduct its mission and automatically land on a landing site after atmospheric reentry. When the flight phase of a space plane is divided into horizontal take-off, orbiting, reentry to the atmosphere and horizontal landing, the technology of reentering the atmosphere and afterwards will be substantiated by development of the HOPE. The flight sequence of HOPE is shown in Figure 1.

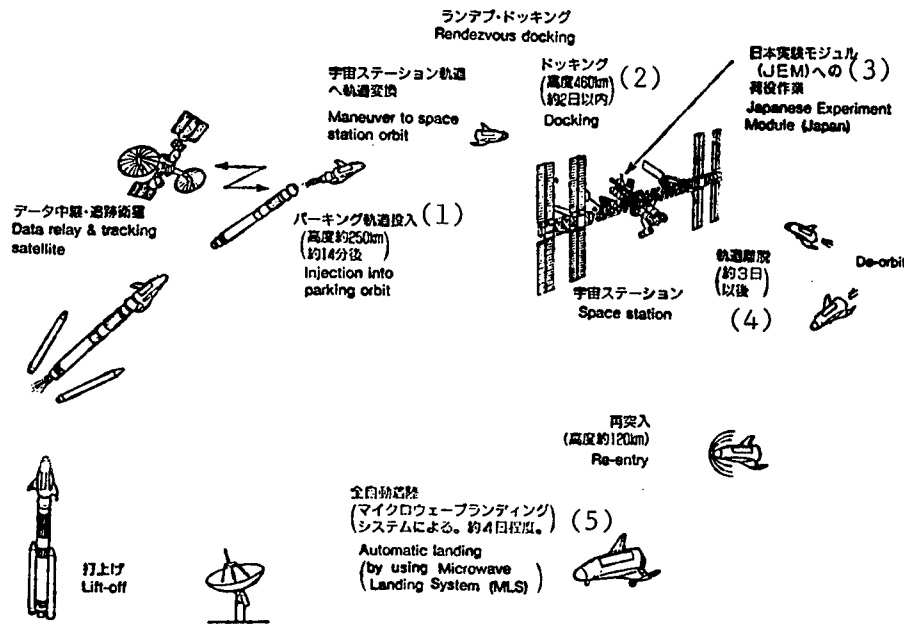

Figure 1. Flight Sequence of HOPE

Key:

1. To about 250 km altitude in about 14 minutes
2. At 460 km altitude within about two days
3. Supplying and discharging operation to JEM
4. De-orbit (after about three days)
5. About four days

3. Mission

Among the needs of a space shuttle transportation, we have been studying the supply and recovery of materials to and from JEM and material experiment on the orbit and physical/engineering experiments for rendezvous and docking as missions for the HOPE.

First, the material supply and recovery mission to and from JEM requires development of a HOPE system compatible with requirements for a space station after substantiating the landing and berthing technologies and clarifying the interface conditions. The working concept on the space station involves (Figure 2) approach and stop near the berthing position with the rendezvous function, berthing of the vehicle, payload handling, and release of the berthing.

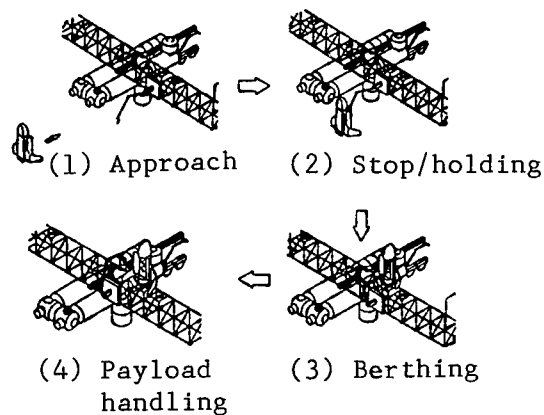

Figure 2. Concept of Working of the Space Station

The material and physical/engineering experiments on the orbit include a substantiating experiment in the space environment, a material experiment under minimal gravitation, and a rendezvous experiment with a target satellite while the HOPE is circling on a low orbit. In spite of time limitation for its missions, it is possible to conduct hazardous experiments difficult for JEM because the HOPE is an unmanned vehicle.

4. System Concept

4.1 Basic Policy

In discussing the concept of HOPE, we have set the following basic policy from reviews of past studies:

- (1) Launch from the Space Center at Tanegashima using an H-II rocket (including improved type).
- (2) Unmanned and full-auto maneuvering.

- (3) After de-orbiting in return, a nongravitation and gliding flight should be taken.
- (4) Horizontal landing on a specified runway strip.
- (5) A specified cargo should be loaded.
- (6) Repeated use should be possible with specified re-use maintenance.
- (7) Service should begin in the second half of 1990s, based on the current technologies of Japan.

4.2 Requirements

The National Space Development Agency of Japan has been promoting studies on the HOPE by setting the following requirements:

- (1) Flight on orbit should be about four days (96 hours).
- (2) Landing runway strip length should be of the 3,000-meter class.
- (3) The cross-range capacity should be about 1,500 km (TBD).

4.3 Study of the Fuselage

We have set airframe size for the HOPE based on the above basic policy and requirements. Figure 3 shows results from the studies thus far.

5. Development Program of HOPE

At present, we are promoting studies that assume the development of HOPE will result in a test flight in FY 1998. In designing the HOPE, development tasks remain in each technical field, particularly aerodynamics, structural material, and guidance control. Further, some dedicated equipment must be developed that differs from rocket and satellite equipment developed domestically thus far.

Aerodynamic design has been inaugurated since FY 1987 for its numerical analysis through programs of the wind tunnel and the Aerospace Technical Laboratory. We have been trying to obtain aerodynamic characteristics of a double-delta wing with a tip fin and improve its fuselage shape.

A test sample of heat-insulation materials have been under study since FY 1982, and we have concluded that it is possible for Japan to manufacture a ceramic tile or carbon material. To obtain physical values, for a guidance control system, we have been testing graphite-polyimide as a candidate structural material since FY 1987. We have been studying a navigation method, particularly the guidance control system of the HOPE, its guidance/control method, and its components.

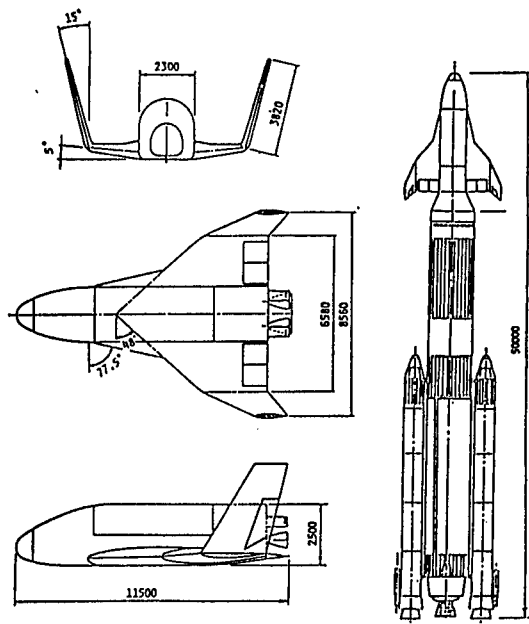

(Unit: meters)

Item	Specifications
Overall length	11.5 m
Overall width	8.56 m
Overall height	4.4 m
Fuselage width	2.3 m
Main wing area	30 m ²
Weight	10 tons in launching
(with load)	7.5 tons in return
Weight (no load)	8.5 tons
Payload	1.4 tons in launching
weight	1.0 ton in return
Wing load in return	250 kg/m ²
Capacity for staying in space	About 4 days
Cross-range capacity	Approximately 1,000~1,500 km
Landing capacity	Automatic landing on a 3,000 meter runway strip

Figure 3. Schematic Appearance of HOPE

Figure 4 shows the forthcoming development schedule. We are promoting steady development by checking functions for each sub-system--such as a small landing test model, a reentry model, and a life-size landing model--and with test flights.

We also expect to streamline the large wind tunnel facilities and landing site to facilitate development.

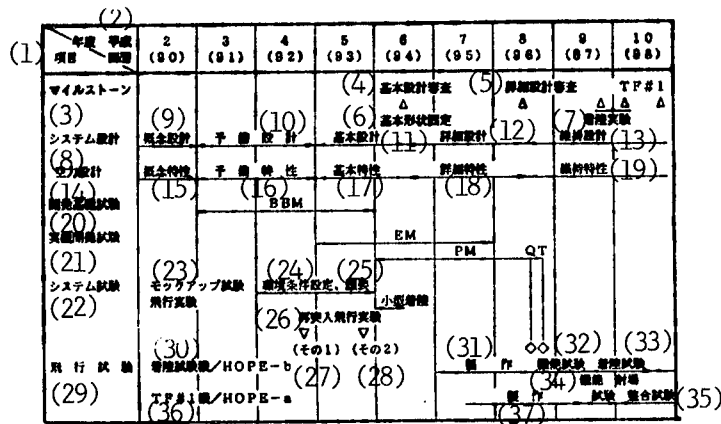

Figure 4. HOPE Development Program Schedule

Key:

1. Item
2. Year Heisei/(A.D.)
3. Milestone
4. Basic design examination
5. Detailed design examination
6. Basic shape decision
7. Landing experiment
8. System design
9. Concept design
10. Preliminary design
11. Basic design
12. Detailed design
13. Retention design
14. Aerodynamic design
15. Concept characteristics
16. Preliminary characteristics
17. Basic characteristics
18. Detailed characteristics
19. Retention characteristics
20. Basic test development
21. Real model development test
22. System test
23. Mock-up test and flight test
24. Setting and mounting environment conditions
25. Small landing model
26. Reentry flight test
27. First test
28. Second test
29. Flight test
30. Landing test model/HOPE-b
31. Manufacture
32. Function test
33. Landing test
34. Function test
35. Launching site matching test
36. TF#1 model/HOPE-a
37. Manufacture

6. Conclusions

The foregoing description of the HOPE concept is based on our studies and on discussions at the Space Development Agency of Japan.

We intend to fully investigate the effects, expandability, and costs of HOPE development that influence the forthcoming space infra-structure and to exchange some development scenarios. On the basis of various alternatives, we will develop a more effective HOPE program.

New development factors will be diversified and become vanguards for a future space plane. This kind of study calls for an all-out effort for Japan. We are determined to promote studies with cooperation from all parties concerned.

Aerodynamic Requirements for HOPE

906C3828E Tokyo HIKOKI SHINPOJIUMU in Japanese Oct 89 pp 40-43

[Article by Toshio Akimoto, Tetsuichi Ito, and Norio Suzuki of the National Space Development Agency; Hirokazu Hozumi, Seizo Sakakibara, and Iwao Kawamoto of the Aerospace Technical Lab: "Study of the HOPE Aerodynamic Shape"]

[Text] 1. Introduction

The National Space Development Agency of Japan and the Aerospace Technical Laboratory have been studying the aerodynamics of HOPE. This article describes design requirements, airframe shape, a wind tunnel test, and forthcoming tasks of the HOPE aerodynamics.

2. Aerodynamic Requirements

The requirements needed in determining the HOPE airframe shape are described below.

(1) Requirements for lift-up.

The HOPE airframe shape, in combination with the launching rocket, should not generate an aerodynamic disturbance moment surpassing the positioning control capacity of the launch rocket.

(2) Requirements in returning to earth.

(a) Requirements for heat-resistive materials.

Aerodynamic heating applied on each component of the HOPE during atmospheric reentry should be within the heat-resistant capacity of the materials used for the HOPE.

(b) Requirements for stability and controllability.

In each flight area of the HOPE, stability and control in the longitudinal and lateral directions for a desired flight should be assured.

(c) Requirements for operability.

The specified cross-range capacity needed for operability in reentry of the HOPE should be satisfied. In addition, landing should be possible under specified landing conditions, including runway length.

(3) Requirements for interface with the space station.

The HOPE airframe should not interfere with its berthing to the space station and other space vehicles or with exchanging payloads.

(4) Requirements for the airframe and mounting of equipment.

The airframe should not affect the entire vehicle structure and mounting of equipment.

3. Discussion on the Aerodynamic Formation

A suggested aerodynamic appearance of the HOPE is shown in Figure 1. The main reasons for selecting the aerodynamic appearance are discussed below.

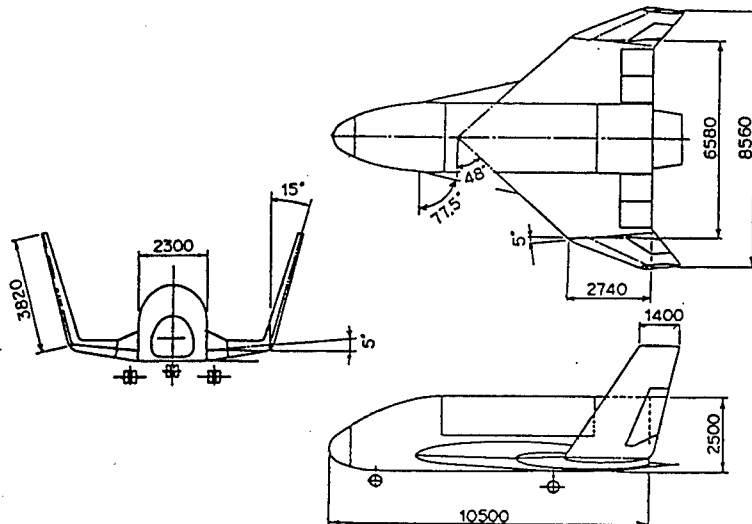

Figure 1. Suggested Aerodynamic Appearance of the HOPE

(1) Fuselage.

Fuselage length, width, and height were determined by a mounting method of payloads on the space station and by a space acquisition of the mounted equipment. The cone head is designed to be dull to minimize aerodynamic heating. It is more effective to have a shorter fuselage length, lower fuselage height, and a flatter fore-fuselage to ensure directional static

stability at a low speed area. A further check and improvement of the fuselage may be required.

(2) Main wing area.

The main wing area of the HOPE was set at 30 m² because of the constraint of the H-II rocket positioning control capacity.

(3) Main wing shape.

In view of their small vertical trim variation in the hypersonic area through low-speed area, we selected a delta wing and double-delta wing. We decided on the double-wing shape because of its better lift characteristics.

A larger leading swept-back angle minimizes aerodynamic heating of the wing's leading section. A smaller angle increases lift inclination. On the basis of these factors, the leading swept-back angle was selected.

(4) Cross section of the main wing.

For the main wing cross section, we are taking into account the aerodynamic heating limit of the leading part, main wing structure with heat-prevention materials, housing performance of the legs and rudders, and reduction of nonlinearity of aerodynamic characteristics, particularly in the transonic area.

(5) Tail wing shape.

We selected the tip-fin type because it does not cause difficulty in berthing to the space station, has good lateral direction characteristics in the hypersonic and high-elevation angle, and good lift characteristics at low speed.

(6) Tail wing shape.

We set span length (height) for the tail wing to maintain directional static stability at low speed. Cant angle was set to increase rudder control in the hypersonic area and to minimize the rolling moment increase to a proper range when controlling the rudder. Tow-out angle was added to reduce aerodynamic turbulence between the fuselage, main wings, and tip fins. At present, it is difficult to have a large tip fin structure, and it may be necessary to review the tip fin shape in view of the need for directional static stability.

4. Wind Tunnel Test

We conducted two wind tunnel tests for the HOPE in FY 1988 and FY 1989. We compared the results with the numerical analysis obtained through a newly developed aerodynamic numerical simulation program by the Aerospace Technical Lab in order to review points in applying the above program to the HOPE aerodynamic design. The wind tunnel tests and aerodynamic numerical

simulation cover tests and analyses of the aerodynamics from a low speed to hypersonic speed and the aerodynamic heating characteristics at a hypersonic speed.

In the wind tunnel test of FY 1988, we tested three different suggestions in terms of airframe size and appearance and checked aerodynamic feasibility for the HOPE. As a result of these tests, we clarified common aerodynamic tasks--such as a poor directional stability at low speed and an unstable phenomenon of the aerodynamic characteristics because of main wing/tip fin turbulence at transonic speed. Therefore, we selected a single airframe for the basic appearance (Figure 1) in the FY 1989 test and varied such parameters as fuselage, main wing, and tip fin shapes mainly to analyze parameter effects. The following features are from the wind tunnel test of FY 1989.

(1) Lateral direction stability.

Directional stability in each speed area with varied tip fin sizes as parameters is shown in Figure 2.

Directional stability was increased in each speed area with a proper tip fin size, directional stability did not improve as much at low and transonic speeds with a short tip fin.

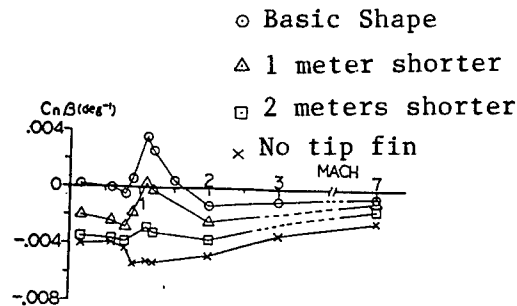

Figure 2. Effectiveness of Tip Fin Size (Schedule Elevation Angle)

(2) Transonic characteristics.

Figure 3 shows the lift characteristics of the transonic area.

As shown by this illustration, lift characteristics change at about an elevation angle of 10° in the transonic area. This change may be because of an increase in aerodynamic turbulence between the main wings and tip fins from the impact wave generated on the main wings. This phenomenon was observed in the FY 1987 wind tunnel test. We tried several measures, without appreciable success, to improve characteristics in the FY 1989 test.

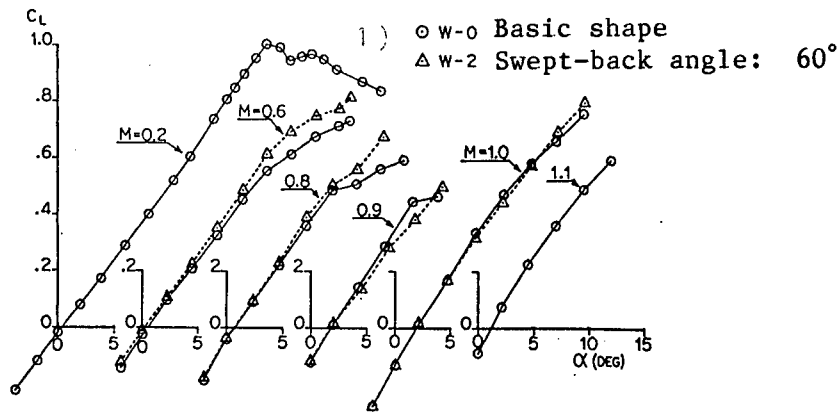

Figure 3. Transonic Lift Characteristics

5. Tasks To Be Solved

The following tasks need to be solved in the future.

- (1) Improvement of the tip fin shape.

There are structural problems for a lengthy and large tip fin. It is necessary to further improve the shape by taking into account directional static stability and an interface with the space station.

- (2) Improvement of aerodynamic characteristics in the transonic area.

Transonic characteristics should be improved by modifying the main wing cross section.

- (3) Improvement of aerodynamic heating characteristic estimation accuracy.

Because aerodynamic heating characteristics greatly influence the HOPE wing loads and the main wing leading swept-back angle, accurate calculation is required. Therefore, it is necessary to streamline aerodynamic numerical simulation programs, including the existent gas effect, and to test with a large wind tunnel facility.

- (4) Analysis of aerodynamic phenomena in the upper atmosphere and in the hypersonic area.

Aerodynamic phenomena, such as rarefied gas effect, existent gas effect, gas jet turbulence effect, boundary layer shift, and impact wave turbulence, in the upper atmosphere and hypersonic area must be examined to analyze their influence on aerodynamic characteristics.

6. Conclusions

The foregoing is a description on HOPE aerodynamic shapes at present. Many tasks remain to be solved for the HOPE as a space vehicle flying with a wide flight range, from the upper atmosphere and hypersonic area to the low-altitude, low-speed area. We invite advice and cooperation from a wide spectrum of fields.

Aerodynamic Numerical Simulation of HOPE

906C3828F Tokyo HIKOKI SHINPOJIUMU in Japanese Oct 89 pp 44-47

[Article by Shigeaki Nomura, Yukimitsu Yamamoto, Susumu Takanashi, Tetsu Ogawa, and Mitsunori Yanagisawa of the Aerospace Technology Lab; Toshio Akimoto of the National Space Development Agency: "Aerodynamic Numerical Simulation of HOPE"]

[Text] 1. Introduction

The H-II rocket-based winged shuttle vehicle HOPE developed by the National Space Development Agency of Japan is Japan's first space shuttle plane. It is hoped that an all-Japan system is established to implement this program.

The winged shuttle vehicle is a space plane with features found in aircraft. This calls for all-out support of the Aerospace Technology Laboratory (ATL). In particular, the aerodynamic numerical simulation of HOPE is a field where ATL has considerable experience. Since FY 1987 ATL has been conducting research jointly to implement this field by making the most of its software expertise (especially the Navier-Stokes analysis) and hardware experience (supercomputer).

This article reports calculated results of characteristics in a wide range of Mach areas for three proposed orbiters and characteristics in a transonic area for the H-II rocket and the orbiters to determine how the present numerical simulation technology can be effectively used in actual aerodynamic design.

2. Airframe Shape and Positioning Angle Requirements

The airframe shapes we used in our calculations (Figure 1) are three HOPE orbiters combined with the H-II rocket.

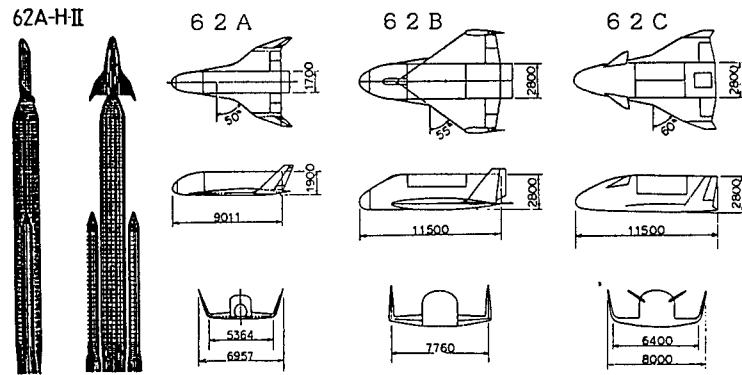

Figure 1. Airframes of Orbiters 62A, 62B, and 62C and the H-II Rocket/Orbiter 62A Combination

For orbiters, the full gas Navier-Stokes calculation was mainly used with $\alpha \leq 40^\circ$ in the hypersonic area ($M = 7$), $\alpha \leq 20^\circ$ in the supersonic and transonic areas, and $\alpha \leq 10^\circ$ ($\alpha \leq 15^\circ$ in the Panel Equation) in the subsonic area. Asymmetric conditions were also calculated with yaw angle β at 5° in the hypersonic and transonic speed areas. For rocket/orbiter combinations, the Euler Equation was used with $\alpha \leq 6^\circ$ and $\beta = 0$ at maximum dynamic pressure in launching.

3. Hypersonic Simulation

3.1 N - S Simulation

The numerical simulation in the hypersonic area for the orbiters 62A, 62B, and 62C was conducted with elevation angle $\alpha \leq 40^\circ$ and yaw angle $\beta = 0^\circ$ or 5° , taking reentry conditions into account under conditions of Mach 7 and Re No. 2.5×10^6 matching the hypersonic wind tunnel test. The numerical calculation was based on the TVD windward difference calculus,^{1),2),3)} with the thin layer N - S taking 640,000 grid points (X: 91, Y: 50, ϕ : 141 points) corresponding to the aerodynamic heating calculation. The gas was a full-gas air and the Baldwin-Lomax algebra turbulence model was used.

Figure 2 shows a pressure contour diagram around orbiter 62A with $\alpha = 40^\circ$, $\beta = 5^\circ$, and $M = 7$. A complicated impact accompanying an asymmetry in the flow field is observed. Results of the force and moment obtained after integrating the pressure (moment) around the airframe surface matches well with those of the wind tunnel test.

6 2 A Pressure Contours
 ($M_\infty = 7.0$, $Re_\infty = 2.5 \times 10^6$, $\alpha = 40^\circ$, $\beta = 5^\circ$)

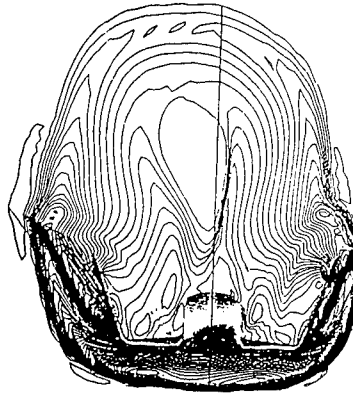

Figure 2. 62A Hypersonic N - S: Pressure Contours

Figure 3 shows the aerodynamic heating calculation results. Heating distribution is shown with dimensionless stagnation point values. The leading wing aerodynamic heating has initially confirmed how much grid distribution should be given to the main curvature direction so that its result does not depend on the grid. A detailed measurement of aerodynamic heating distribution in a hypersonic wind tunnel for HOPE has not been accurately done yet, but the distribution results on the underneath center line are approximately in agreement.

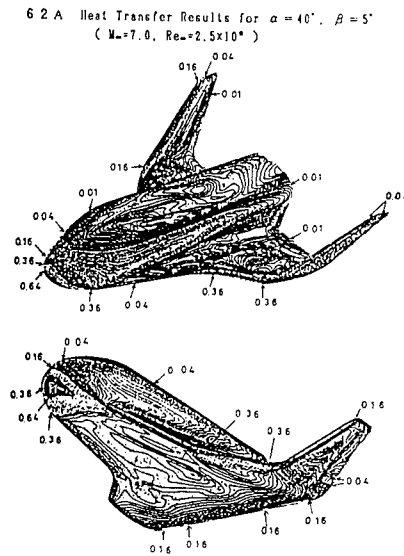

Figure 3. Aerodynamic Heating N - S: Dimensionless

3 - 2. Newtonian Calculation

We created the Newtonian calculation codes,⁴⁾ including the aerodynamic rudder face, and applied them to the aerodynamic calculation of the three HOPE orbiters with a very good result, matching that of a wind tunnel test (Figure 4).

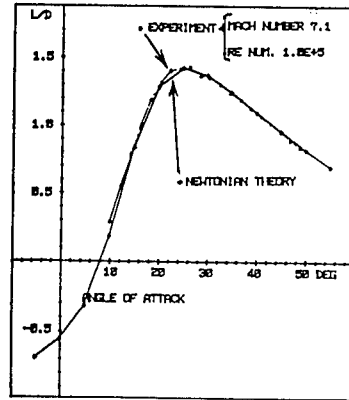

Figure 4. 62B Newtonian Calculation: $L/D \sim \alpha$

As a result of this calculation, it has been proven that the aerodynamic calculation in the full gas hypersonic area has a satisfactory accuracy with the Newtonian theory. Because the calculation takes very little time, it can be used effectively for system analyses, among others.

4. Subsonic, Transonic, and Supersonic Simulations

4 - 1. N - S Simulation

The thin layer approximation N - S was calculated by the upwind TVD method over subsonic, transonic, and supersonic speed ranges for the HOPE orbiter, 62B.^{5),6)} The calculation conditions are shown in the following.

	M	Re($\times 10^6$)	α	β
Subsonic	0.4	5.31	0 ~ 10°	0°
Transonic	0.9	5.31	0 ~ 20°	0°
	0.9	5.31	0 ~ 10°	5°
Supersonic	2	1.0	0 ~ 20°	0°

Figures 5 and 6 show simulation results of the cross flow with β at 5° in the transonic area and the shock wave on the airframe surface.

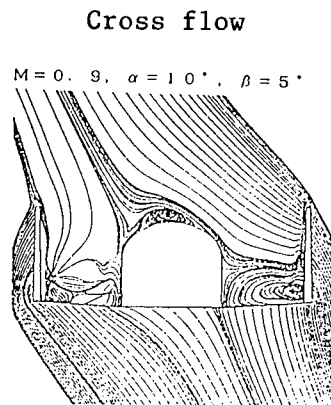

Figure 5. 62B Transonic N - S: Cross Flow

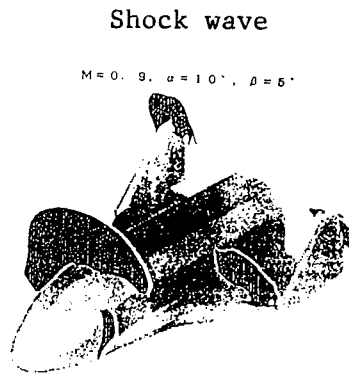

Figure 6. 62B Transonic N - S: Shock Wave

As shown by the illustrations, a shock wave is generated between the windward tip fin and the fuselage when yaw angle is taken and a large separation area, deemed to result from it, is caused between them in contrast with leeward asymmetry.

Experimental results show that this asymmetry induces the revolution moment, causing an instability of C_l and C_n β in the transonic area. To solve an aerodynamic problem of the HOPE with a large tip fin in the transonic area, analytical results in the flow area by CFD provide an important clue.

4 - 2. Panel Method Analysis

Aerodynamic calculations for the three HOPE orbiters were conducted with the Panel method⁷⁾ for a low speed of Mach 0.15.

Because the 62B orbiter has a canard, the canard lift was obtained (Figure 7) from the aft current. The top view pressure contours are shown in Figure 8. Because it has a port tail that differs from those of conventional aircraft, an aft current is given succeeding from the fuselage for calculation. However, its result does not satisfactorily agree with the experimental result. This may be because of an increase in lift as the negative pressure area increases with the delta wing's leading separation current.

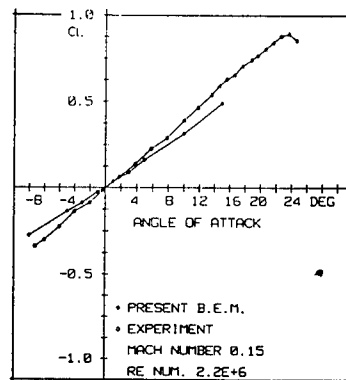
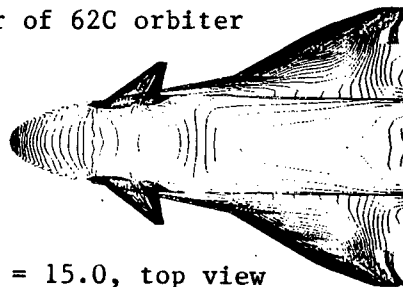

Figure 7. 62C Panel Method: $Cl \sim \alpha$

Pressure contour of 62C orbiter



$M = 0.15, \alpha = 15.0, \text{ top view}$

Figure 8. 62C Panel Method: Pressure Contour

5. HOPE/Rocket Combination

When an HOPE orbiter attached on the top of H-II rocket is launched, the main wings of HOPE generate a large revolution moment caused by beam wind. To minimize this moment within a control capacity range of the rocket, the main wing area must be limited--indicating the importance of the moment calculation.

The rocket has two SRBs and, on its top, an orbiter with tip fins.

In numerical simulations, it is necessary to drastically change some grid sizes. Therefore, we formed different grids locally: (1) rocket and orbiter fuselage (123 x 29 x 30 points), (2) SRB (71 x 36 x 20 points), and (3) orbiter wings (111 x 56 x 21 points). We superimposed them in three dimensions.

We solved an Euler equation with a TVD scheme. The calculation result agreed with experimental values (marked \square in the graph) as shown in Figure 10.

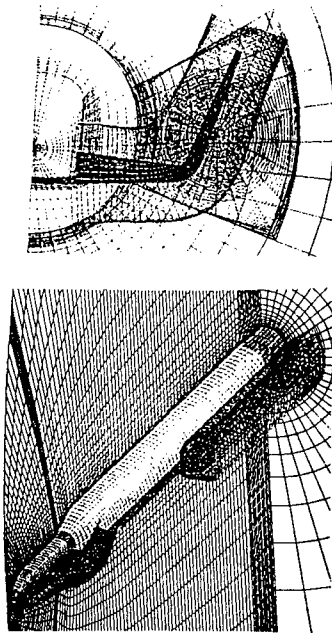

Figure 9. 62A-H-II Rocket: Superimposed Grids

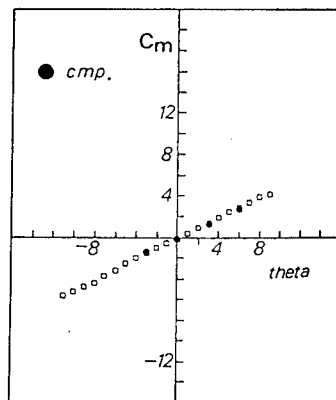

Figure 10. 62A/H-II Euler: $C_m \sim \alpha$

6. Conclusions

We obtained valuable results for aerodynamic designs by conducting aerodynamic numerical simulations for HOPE over a wide speed range from the subsonic to hypersonic areas. It was confirmed that H-II rocket/orbiter combinations can be applied in aerodynamic designs.

We are going to further compare results obtained in experiments and calculate the aerodynamic rudder effect. More detailed calculations for the existent gas effect in reentering the atmosphere must also be studied.

References

1. Y. Yamamoto, AIAA Paper 88-2615, 1988.
2. Y. Yamamoto, AIAA Paper 89-0273, 1989.
3. Y. Yamamoto, AIAA Paper 89-1699, 1989.
4. Mitsunori Yanagisawa, NAL TR-722, 1982.
5. Susumu Takanashi, NAL TR-1009.
6. Masakazu Tachimana, Susumu Takanashi, NAL SP-9.
7. Mitsunori Yanagisawa, NAL TR-835.
8. T. Ishiguro, S. Ogawa, Y. Takakura, NAL TR-950T, 1987.
9. S. Ogawa, T. Ishiguro, Y. Takakura, Numerical Fluid Mech. Vol 20, 1988.

Heat Resisting Structure of HOPE

906C3828G Tokyo HIKOKI SHINPOJIUMU in Japanese Oct 89 pp 48-51

[Article by Masataka Yamamoto, Tadashi Matsumoto, Hidehiko Mitsuma, Tomoyuki Kobayashi, Motohiro Atsumi, and Hirobumi Tamura of the National Space Development Agency: "Study of the Concept of HOPE's Heat Resisting Structure"]

[Text] 1. Introduction

The HOPE airframe is exposed to severe thermal and mechanical environments during launch, orbit, reentry, and landing. In particular, its design concept calls for a thorough investigation of a heat resistant design to protect the main structure and mounted equipment from high temperature caused by aerodynamic heating during reentry, as well as in the design structure for manufacturing a light airframe.

This study describes the feasibility of a model by setting a concept model (Figure 1) of the airframe structure satisfying requirements for the system, aerodynamics, and component program.

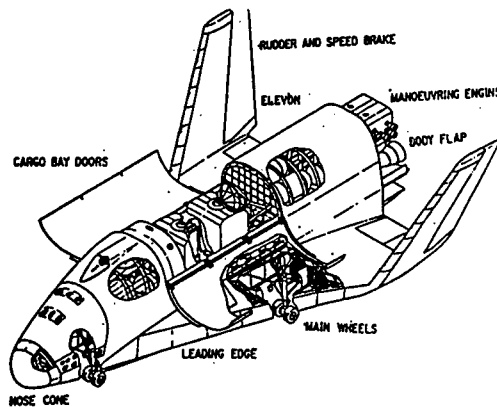

Figure 1. HOPE Airframe

2. Structural Design Requirements

(1) Airframe load requirements.

The main load types and load values applied to the airframe during main phases from handling on the ground, orbiting, reentry, and landing are shown in Table 1.

Table 1. Applied Mechanical Load Conditions to Airframe Through Flight

Overall load	Dynamic pressure	$q_{\max} = 5.4 \text{ ton/m}^2$ $M \approx 70 \text{ ton}\cdot\text{m}$ $S \approx 17 \text{ ton}$
Overall rigidity	Longitudinal	30 Hz
	Lateral	10 Hz
Acceleration (static)	Longitudinal	5 G
	Lateral	0.7 G
Acoustic		155 dB (overall)

(2) Thermal environment requirements.

We conducted thermal analysis on the entire airframe based on the orbiting and reentry operational conditions and obtained temperature conditions imposed on main structure materials (C/Pi, C/C). Table 2 shows the temperature conditions of main structure materials.

(3) Mounting environment requirements.

We set environment requirements individually for external materials, such as the heat protecting material, and for the internal equipment, such as electronic devices, the actuator, and landing gears.

3. Structural Frame Study

We studied the structural format of each part based on the dimensions and specifications of the airframe, component program, H-II rocket interface, characteristics of heat-resistant structure materials, and structural design requirements.

(1) Heat-resistant structural frame.

Outboard heat protection and inboard insulator materials are provided on the main structural frame (heat-resistant CFRP: C/Pi) to protect the airframe

from high temperature caused by severe aerodynamic heating (Figure 2). However, in a high-temperature area above 1,300°C, C/C materials will be used direct with inboard insulator materials.

Table 2. Primary Structural Temperature Subjected Through Flight

Mat.	Event	Temperature °C
CF/Pi	Ascent	Maximum 130 (forward fuselage) Minimum no critical
	On orbit	Maximum 89 (forward fuselage) Minimum -80 (forward fuselage)
	Reentry/landing	Maximum 300 (overall) Minimum no critical
C/C	Ascent	Maximum 317 (nose cone) Minimum no critical
	On orbit	Maximum 51 (nose cone) Minimum -59 (nose cone)
	Reentry/landing	Maximum 1700 (leading edge) Minimum no critical

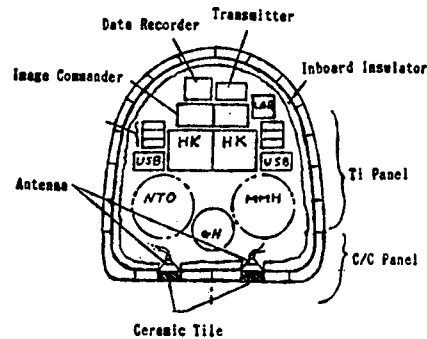

Figure 2. Heat-Resistant Structure of Forward Fuselage

(2) Fuselage structural frame

The cargo bay is positioned in the mid-fuselage. Because it is a large notch portion requiring many partial reinforcements, a panel/longeron/frame system is used for the mid-fuselage.

(3) Main wing structural frame.

The main wing is a double delta with a box-beam structure composed of several beams and upper/bottom panels.

This frame is resistant to shearing force, flexural moment, and twisting moment.

(4) Tip fin structural frame.

The tip fin is a large structure 3.8 meters high at present, and we assume that a box-beam structure resistant to flexural and twisting forces is proper for minimizing flutters.

(5) Wing/fuselage joint system.

Because the upper part of the mid-fuselage is a notch structure, the wing load is transmitted to the fuselage with a carry-through system by providing center wings underneath the aft fuselage. The main frame structure based on the above studies is shown in Figure 3.

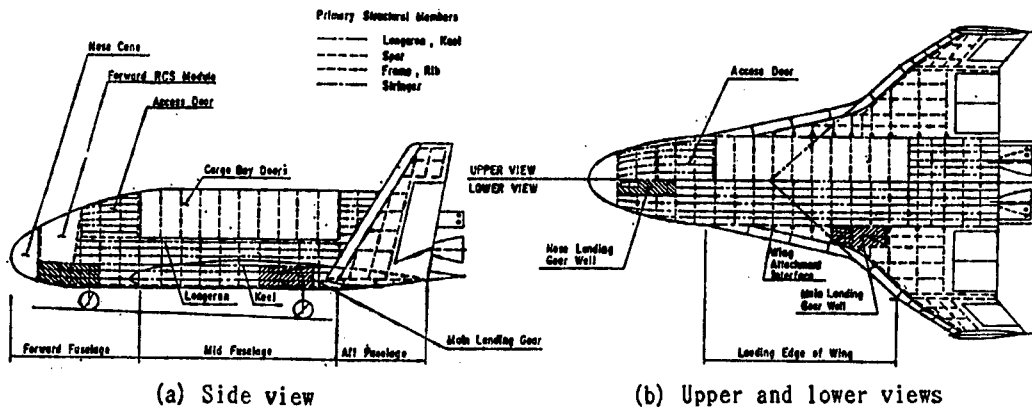

Figure 3. Frame Structure

4. Structural Materials Studies

(1) Main structural materials.

We conducted a feasibility study of frame materials by checking each of the candidate materials--Al alloy, Ti alloy, carbon fabric-reinforced epoxy (C/Ep), and C/polyimide (C/Pi).

As a result of this study, we found C/Pi excellent in heat resistance, specific strength, and specific rigidity (Table 3), allowing the manufacture of a light airframe. We are now conducting a basic test to obtain molding techniques and basic data from this material.

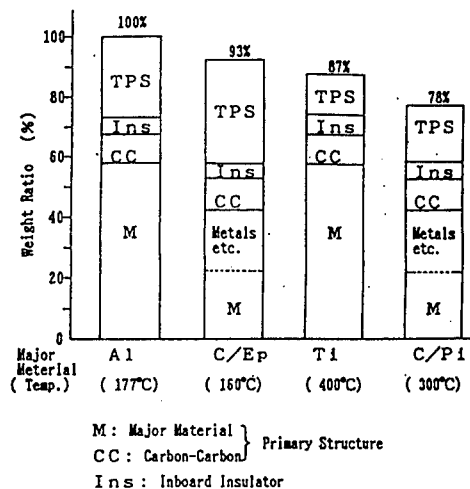

Table 3. Comparison With Structure Weight for Constituent Materials

(2) Heat protection material.

For heat protection materials, five materials are under study with requirements for reuse, easy maintenance, setup configuration of the airframe, and lightness. The setup configuration of the airframe is determined taking into account the heat resistance and surface temperature of each heat resisting material. Figure 4 shows the setup configuration of heat protection materials.

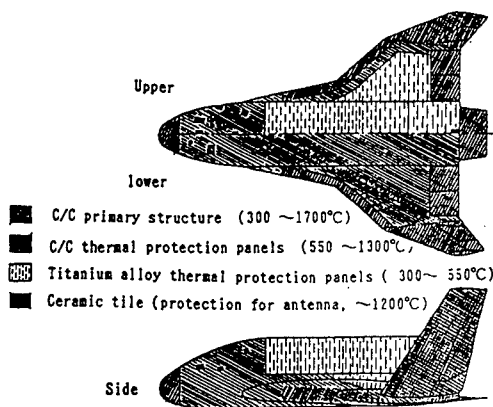

Figure 4. Setup Configuration of Thermal Protection Panels (Example)

- Ceramic tile (maximum operating temperature: 1,250°C)
- Ceramic-based insulator (650°C)
- Titan alloy-based panel (550°C)
- Nickel alloy-based panel (1,000 °C)
- Carbon/carbon panel (1,300°C)

On the basis of the above results, applied materials for each substructure and their structural diagram are shown in Figure 5.

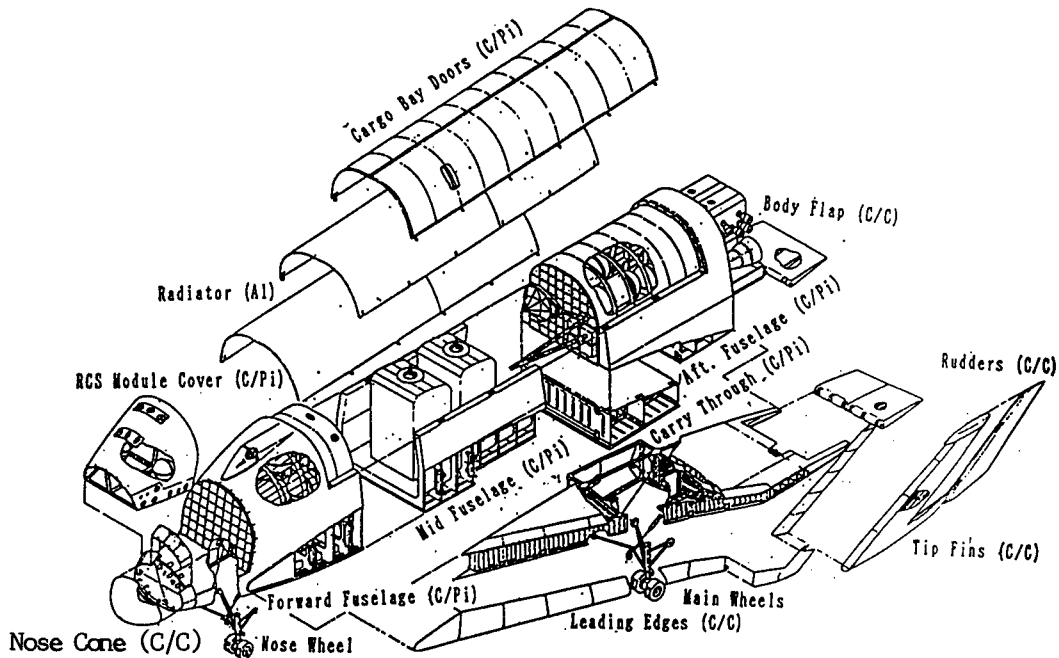

Figure 5. Substructures and Constituent Materials

(3) Inboard insulator material.

For inboard insulator materials, our research was based on requirements for low thermal conductivity and specific gravity, much specific heat, and no toxic gas. We found that ceramic-based materials (for example, Litflex KG-25 under 300°C or Finelex under 1,500°C) have excellent characteristics).

5. Structure/Heat Resistance Analysis

(1) Structural analysis.

On the basis of the study results of structural frames and applied materials, we created a finite element model for structural analysis and analyzed its strength and rigidity. Figure 6 shows the finite element model used in the analysis, and Table 4 shows the main modes and eigen values.

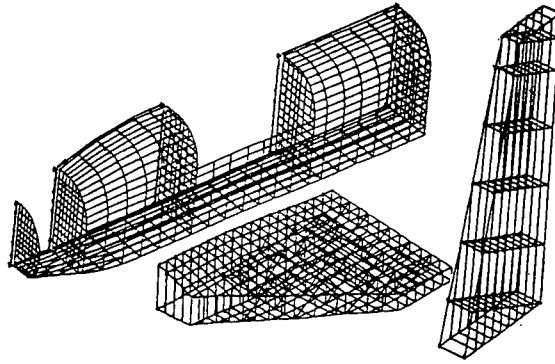

Figure 6. Finite Element Model for Structural Analysis

Table 4. Eigen Values and Eigen Modes of Body

Number	Eigen Value (H_z)	Mode
1	6.2	Bending of fuselage
2	11.2	Bending of wings and tip fins
3	25.5	Longitudinal

(2) Analysis of heat resistance.

We set a temperature hysteresis imposed on the airframe in operation and analyzed the temperature of each airframe and the heat stress generated on main sections. The highest and lowest temperatures generated on each airframe are shown in Table 2. When we checked the heat stress generated in each section caused by a temperature rise resulting from aerodynamic heating generated after the reentry, we found considerable stress (maximum main stress on the main wings: 45 kg/mm^2) on the main wings and fuselage 2,700 seconds after reentry, possibly requiring a forced cooling.

6. Conclusions and Forthcoming Technical Tasks

To create a conceptual design model of the HOPE airframe structure, we conducted structural and heat resistance analyses by checking its structural frames and applicable materials. With this check and study, we determined the feasibility of the model. The following technical tasks need to be solved in forthcoming designs: (1) manufacturing technology of structural materials (C/Pi, C/C, heat protection panels) and acquisition of their data, (2) clarification of the temperature environment imposed on the airframe and heat protection measures, and (3) optimum designing and manufacture of a light airframe from the viewpoint of structural designs.

Guidance Control Technology for HOPE

906C3828H Tokyo HIKOKI SHINPOJIUMU in Japanese Oct 89 pp 52-55

[Article by Etsusada Takizawa, Hitoshi Mineno, Yuichi Sato, Tatsushi Izumi, Toshiki Morito, and Nobuyoshi Hayashi of the National Space Development Agency: "Study on the Guidance Control Technology for HOPE"]

[Text] 1. Introduction

The National Space Development Agency has been studying the H-II rocket-based winged shuttle plane HOPE (H-II Orbiting Plane).

The HOPE is designed for unmanned flight in space (Figure 1). Its guidance control system needs to automatically manage and execute the HOPE flight. The Agency is studying the following guidance control technology jointly with the Aerospace Technology Lab, in hopes of designing this kind guidance control system for the HOPE. This article describes past study results and forthcoming tasks for the HOPE guidance control technology, including:

- (1) System configuration and management.
- (2) Navigation, guidance, and control.
- (3) Equipment.

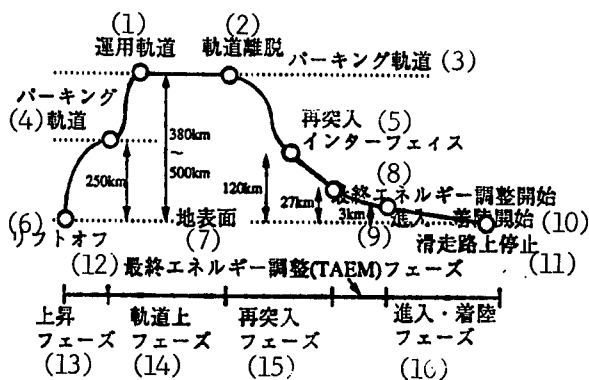

Figure 1. Representative Flight Profile

[Key on following page]

Key:

1. Operation orbit
2. De-orbiting
3. Parking orbit
4. Parking orbit
5. Reentry interface
6. Lift-off
7. Ground surface
8. Final energy adjustment start
9. Approach
10. Landing start
11. Stop on the runway
12. Final energy adjustment (TAEM) phase
13. Soaring phase
14. Orbiting phase
15. Reentry phase
16. Approach/landing phase

2. System Configuration and Management

Functions required of the HOPE guiding control system are analyzed and reviewed for a configuration of the guiding control system. The basic configuration consists of an automatic system and a remote control system (Figure 2).

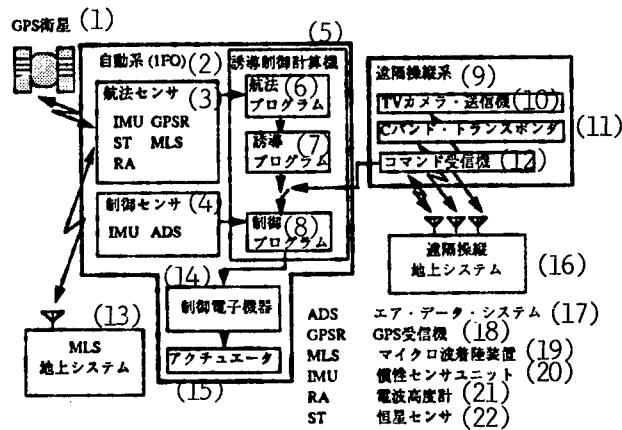

Figure 2. HOPE Guidance Control System Configuration (Suggested)

Key:

1. GPS satellite
2. Automatic system (1FO)
3. Navigation sensor
4. Control sensor
5. Guidance control computer
6. Navigation program
7. Guidance program

[Key continued on following page]

[Key continued]

8. Control program
9. Remote control system
10. TV camera/transmitter
11. C-band transponder
12. Command receiver
13. MLS ground system
14. Controlling electronic equipment
15. Actuator
16. Remote control ground system
17. ADS: air data system
18. GPSR: GPS receiver
19. MLS: microwave landing system
20. IMU: inertia sensor unit
21. RA: radio altitude meter
22. ST: star sensor

The automatic system is composed of equipment and its software for all automatic flight. The remote control system is composed of a backup to the automatic system near the landing site. The latter system may become larger as the remote control system gets more complicated. A simple configuration is maintained at present because its basic role is safe flight.

In the future, we will study landing feasibility using a remote control system, among others, and, as a result, the functions and configuration of a remote control system may be reviewed.

The HOPE may have to have a redundant management system because it has to fly for long periods of time. With this in mind, the automatic system shown in Figure 2 has a 1FO (1 Fail Operative: functions and performance do not deteriorate even if a failure occurs in the same operation system). A redundant management method to realize this 1FO is one of the tasks to be tackled. In case of the HOPE, the flight condition between de-orbiting and landing in particular changes dynamically, and it is necessary to detect, localize, and separate any failure in real time. We have concluded that a redundant management method should have a triple structural majority system as its base. Further, redundant management for the navigational sensor and guidance control computer should be done by the guidance control computer, and the controlling electronic equipment and actuator should be processed with controlling electronic equipment.

In the future it may be necessary to conduct a detailed design analysis of the logic, taking into account hardware characteristics, and to review redundant management and testing methods.

3. Navigation, Guidance, and Control Studies

3.1 Navigation studies

Table 1 shows the navigation accuracy considered necessary for a flight of the HOPE.

Table 1. Accuracy Required of Navigation (3 α Value)

Phase		Navigation Allowance		
		Position Error (meters)	Velocity Error (m/s)	Attitude Error (arcsec)
Orbit	In ending in-flight alignment	N/A	0.1	216
	In ending position speed renewal	100	N/A	N/A
	In starting de-orbiting	100	N/A	864
In ending black-out	Altitude Down range Cross range	3000 10000 9000	N/A	N/A
TAEM interface	Altitude Down range Cross range	2000 1800 4500	30 30 30	N/A
Approach/landing interface	Altitude Down range Cross range	300 300 300	0.29 0.2 0.32	N/A
Grounding	Altitude Down range Cross range	1 16.5 16.5	0.3 0.3 0.3	N/A

At present, it is expected to take 96 hours from launch to landing. It is impossible to satisfy the accuracy demand only with the inertia navigation used in conventional rockets. Composite navigations are required.

We traded off parameters of various navigation supports in each phase, taking into account performance evaluations by common-distribution analysis and operabilities. From this, we have set the structures shown in Figure 3 as the present base line.

Further, we have selected the mounting Carman filter's status quantity and demanding accuracies of the renewal cycle and navigation support equipment from common-distribution analysis. Tasks to be tackled include development of the mounting filter and evaluation of the composite navigation system using composite navigation equipment.

Phase Using Navigation Support Equipment

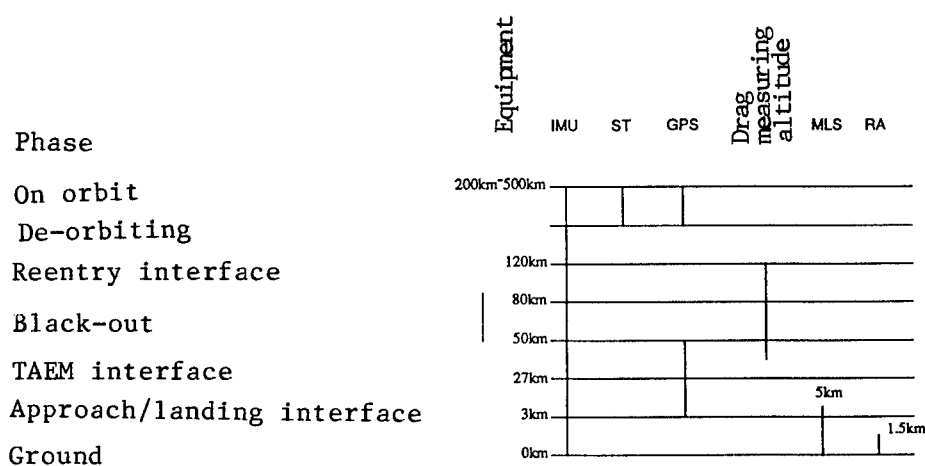

Figure 3. Navigational System Base Line Structure

3.2 Guidance Studies

We have studied orbital conversion, de-orbiting, reentry, final energy adjustment, and automatic landing guidance. The following describes only reentry guidance and automatic landing, regarded as technically critical.

Reentry guidance corrects orbiting errors generated by various turbulences that aerodynamic heating and load constraints when flying toward a target point.

There are many types of reentry guidance, but we chose the closed-home system, taking into account such things as its orbiting control flexibility and the capacity of the guidance control computer.

Figure 4 shows a concept of a closed-home system and recovery corridor formed by aerodynamic heating constraints.

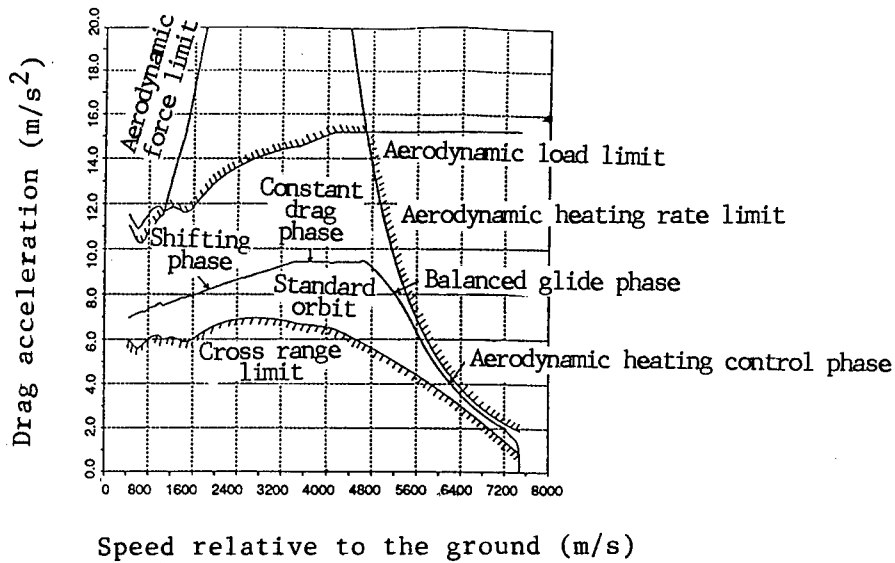

Figure 4. Conceptual Diagram of Recovery Corridor and Closed-Home Guidance

An actual flight orbit will be shifted from the standard orbit by external turbulences, such as an error in the aerodynamic characteristics calculation or atmosphere model. Therefore, the HOPE flight environment may be different from flying on a standard orbit, but it should not be over each of the limits.

To evaluate and verify the closed-home guidance system, it is necessary to conduct a guidance simulation, including external turbulence. Figure 5 shows a result of a aerodynamic heating rate simulation, the most critical limit, in the early reentry phase.

This example shows the necessity of an allowance of about 15 percent in the aerodynamic heating rate in designing a standard orbit. As a result of the above simulations, the closed-home guidance method has been evaluated as reasonable, and a reentry guidance algorithm has almost been determined. These checks have also led to demands for the airframe design, such as aerodynamic characteristics and wing surface loads.

The aim of HOPE is automatic landing on a 3,000-meter-class runway. The standard runway of the space shuttle is 4,500 meters. High-accuracy landing guidance is needed for the HOPE, for which we must come up with a solution.

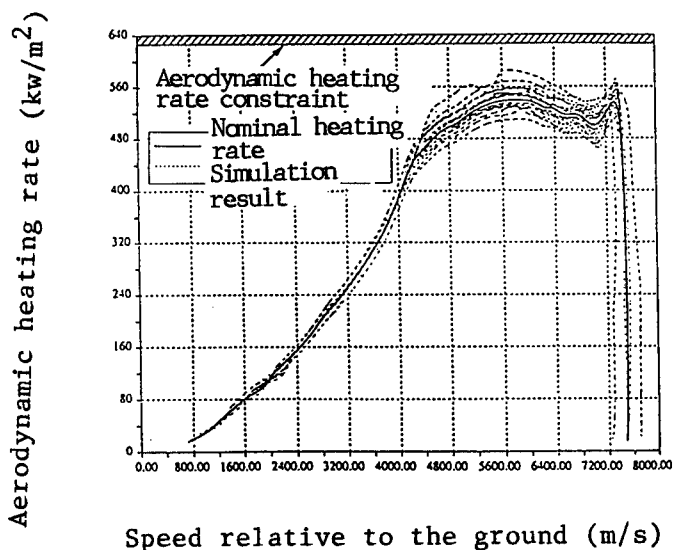

Figure 5. Example of Reentry Simulation (Aerodynamic Heating Rate)

As a result of our study, it was known that high-landing accuracy is possible by taking a large, balanced-descent angle in the steep glide slope flight, making the most of the unmanned flight feature of the HOPE (Figure 6), and then rising as swiftly as possible at a low altitude with a flare operation.

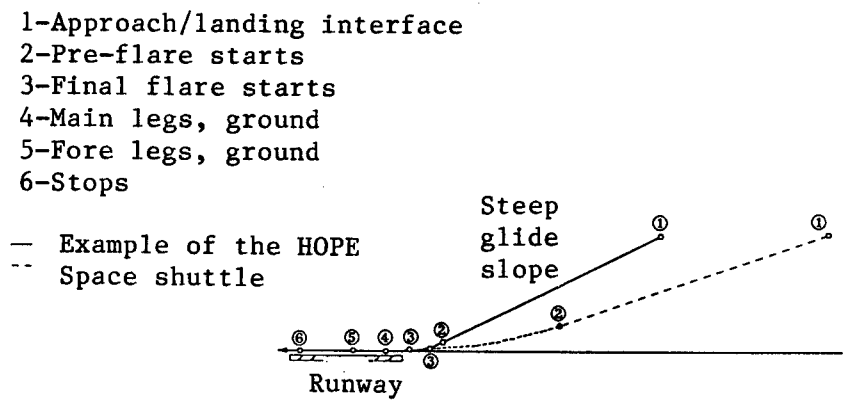
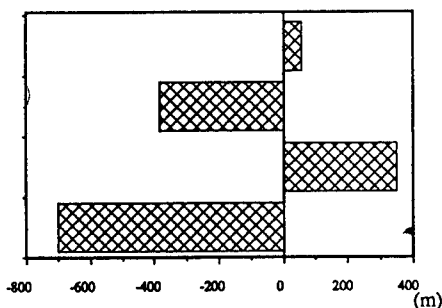

Figure 6. Example of Approach/Landing Phase of Flight Route

An example of 6-free-degree simulation, including control under turbulent wind, is shown in Figure 7.

Suggested HOPE's maximum energy system
 Suggested HOPE's minimum energy system
 Shuttle's maximum energy
 Shuttle's minimum energy



Positioning error relative to the ground

Simulation Case

	Maximum energy	Minimum energy
$\Delta L/D$	+ 10 %	- 10 %
Δh	+ 300 m	- 300 m
$\Delta \gamma$	+ 4 deg.	- 4 deg.
ΔV_{EAS}	+ 20 KT	- 20 KT
Wind	Forward (Pex=1%)	Against (Pex=1%)

$\Delta h, \Delta \gamma, \Delta V_{EAS}, \Delta L$ Interface errors

Figure 7. Results of a Landing Simulation

As this diagram shows, it is clear that accuracy has been improved in comparison with the space shuttle.

As a result of analysis under several turbulent conditions, including the result shown in Figure 7, we have estimated that the HOPE will be able to land and stop on a 3,000-meter-class runway. However, further detailed studies will be needed.

3.3 Control Studies

We studied controls of each phase of on-orbit, de-orbit, reentry, and landing. Here we describe the status of our studies on reentry and landing controls, along with most tasks to be settled. In this phase, HOPE characteristics to be controlled change dynamically, and errors must be approximated in the aerodynamic characteristics calculation, requiring an adaptable control rule.

Further, the actuator to be used has to be exchanged from the RCS to the rudder as a result of aerodynamic force and angle of elevation. This exchange timing and its control rule at the time of exchanging become

significant. Further, it has been shown in past studies on aerodynamic shape that it is desirable for the HOPE to lessen static stability longitudinally and laterally. It is vital in control tasks to determine an allowable level of static stability lessening.

Using aerodynamic characteristics approximated from wind tunnel and other tests, we designed control rules, conducted simulation analysis, and confirmed the following results.

- (1) A designing method for the control rule from reentry to landing has been clarified.
- (2) A sizable capacity is needed in the rudder actuator, but it has been proven that stable flight is possible without static stability. It may also be possible to make the tip fin smaller.
- (3) It is possible to exchange the actuator from the RCS to rudder at a higher altitude (lower aerodynamic force) compared with a space shuttle, enabling reduction in RCS thrust and thrust powder quantity. We may now need to analyze designs more in detail, matching them with the airframe design.

As described above, it is necessary to proceed with designing by making a close interface between control design and airframe design, including aerodynamics. For this interface, a simple barometer requiring no complicated simulations is needed. We are now working on this barometer, based on the results of simulation tests conducted so far.

4. Equipment Studies

The HOPE needs much equipment, and we have reviewed specifications for each type of equipment and for development programs. As a result, we have set specifications for main equipment (Table 2).

We have judged that technical accumulation might be necessary for the equipment shown in Table 2, and we have manufactured critical components for that equipment on a trial basis.

5. Conclusions

On the basis of studies thus far, the system configuration for managing and controlling HOPE flight automatically has been clarified. We could trade off formats regarding its navigation, guidance, and control and determine the basic algorithms for them. From these studies, we are sure that the HOPE will be able to automatically navigate in space, reenter, and land on a 3,000-meter-class runway.

We will continue to conduct detailed design analyses of navigational, guidance and control, and manufacture test equipment, accumulating basic technologies for a guidance control system.

Table 2. Required Specifications for Main Equipment

Equipment Name	Main Demanded Specifications
Guidance control computer	(1) 32-bit operation (2) Operation speed of 1 MIPS
Inertial sensor unit	(1) Reduction of dither noises
GPS receiver	(1) TIFF: 120 sec. or less (2) Number of channels: 5 (3) Short range accuracy: 50 m (3 σ)
Star sensor	(1) Tracking rate: 0.2/sec. or more (2) Demanding accuracy angle: 60 arcsec (3 σ)
MLS measurement angle receiver	(1) Directional angle measurement range: $\pm 40^\circ$ (2) High/low angle measurement range: $\pm 0.9^\circ \sim 30^\circ$ (3) Demanded accuracy PFE: $\pm 0.12^\circ$ (2 σ), CMN: $\pm 0.06^\circ$ (2 σ)
MLS distance measurement equipment	(1) Demanded accuracy PFE: 30 m, CMN: 18 m (2 σ)

References

1. Izumi, et al., "Navigation and Guidance of the H-II Orbiting Plane," XIth IFAC Symposium, 1989.
2. Takizawa, et al., "Automatic Landing of the HOPE," Japan Aerospace Society, 20th annual conference.
3. Sato, et al., "Navigation and Guidance Analyses of the HOPE in the Reentry Phase," 32nd Space Science Association.

Rendezvous/Docking Technology for HOPE

906C3828I Tokyo HIKOKI SHINPOJIUMU in Japanese Oct 89 pp 56-59

[Article by Yasushi Wakabayashi, Hiroyuki Nakamura, and Isao Kohno of the National Space Development Agency; Osamu Okamoto of the Aerospace Technology Lab: "Concept of the HOPE Rendezvous and Docking"]

[Text] 1. Introduction

Rendezvous/docking (RVD) technology is an important orbital technology for the HOPE and a common technology imperative for forthcoming wide-space activities--from supplying materials to the space station to completing the recovery mission.

This article describes the RVD system's concept, flight sequence, main study contents, and orbital verification tests regarding studies on the presently developed RVD technology.

2. System Concept and Flight Sequence

Our RVD system has targets for the following RVD missions.

- RVD to the space station by a Japanese unmanned space vehicle (SS-RVD): HOPE with space station.

- RVD with each of Japan's unmanned space vehicles (DO-RVD): HOPE with platform.

With an unmanned space vehicle as a chaser, RVD will be made to a cooperative target space vehicle. This kind of system is being studied and developed in the United States and Europe. What it should be needs to be discussed from the viewpoint not only of technology but also of international joint work. Its basic requirements, though they are focal points of studies, are as follows.^{1,2}

- (1) Securing safety, operability, and efficiency.
- (2) Automation and high accuracy.
- (3) Remote control piloting and ground-control technologies.

RVD of unmanned space vehicles drastically reduces constraints, such as the crew time line and matching with manual systems present in a manned flight, meanwhile requiring an automated system using high-accuracy sensors or a system including high-level remote control technologies.

Further, a safety standard condition of RVD, including RVD with manned vehicles, is that "no disastrous conditions, such as collision, result from even two consecutive abnormal failures of H/W, S/W, or operators (2FS)." In particular, a real-time RVD is needed in the proximity operation zone, requiring a highly automated mounting system and technologies on the ground to control its operation.

At present, we have adopted a highly automated mounting system and, while aiming at its realization, have also studied human-interface technologies, such as remote control command and ground control.

Figure 1 shows a typical flight profile for the HOPE SS-RVD mission.

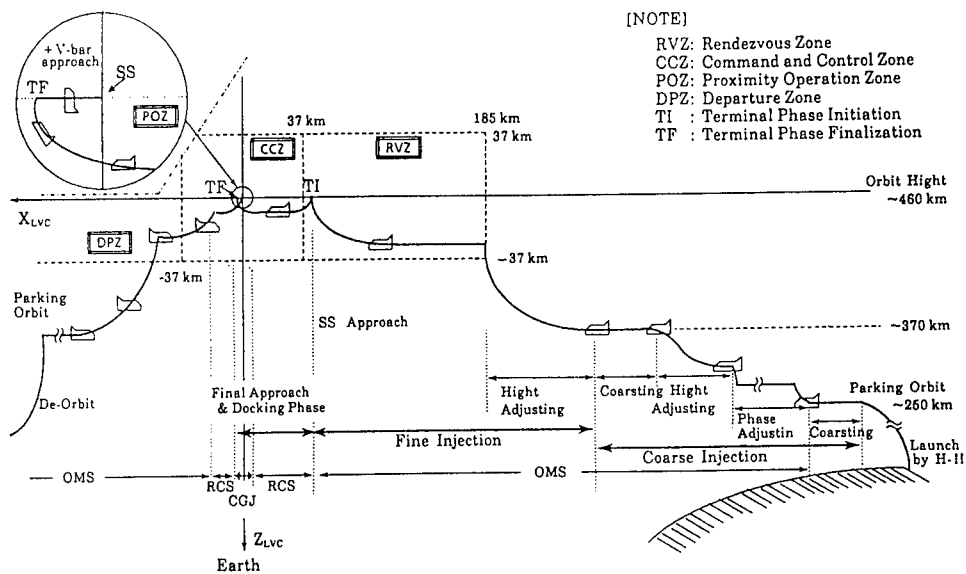

Figure 1. HOPE SS-RVD Mission Profile

In the following, each phase along the RVD sequence from launching to docking will be described.

- (1) Launching/orbit adjusting phase: after injection to an orbit face similar to the target by the H-II yaw steering, about six maneuvers will be made to adjust altitude, phase, orbital face, and arrival time before arrival at T1, relative stop point about 50 km after the target.

This phase takes 20 to 30 hours and covers the major portion of required rendezvous time. In this phase, a composite automated navigation with GPS-IMU-ST and an automated flight with the onboard targeting and guidance command, based on the Hohmann/Lambert algorithm, will be executed. The ground system will determine a sub-real-time orbiting, renew the target orbit, and monitor/evaluate the mounting system with DRTS.

(2) Relative approach: after establishing the communication circuit with the target at T1 point, the HOPE will fly over a noncollision orbit a few kilometers lower than the target orbit and arrive at TF, relative stop point about 100 meters, in front of the target and from below after a fly-around.

Here, the relative navigation by (dif) GPS, rendezvous laser radar, and rendezvous flight control meeting any error or failure will be the focal points. In the SS-RVD, this phase and subsequent phases will be under the control of the space station, which will transmit relative navigation data, with the ground system backing up its safety.

(3) Final approach: from the TF point, the HOPE will approach a docking start point/berthing point by slowing gradually at almost the same altitude lineally.

The flight control mission in this phase is vital, particularly in the proximity of a few tens of meters in approaching over the collision course. It is necessary to have collision avoidance maneuvering and retreating functions by an onboard automation system in case of circuit disconnection failure. In the space station RVD, we considered a scenario, such as a remote control approach by the space station crew, as envisioned by the U.S. OMV or a guidance by an automated command.

(4) Docking: for the DO-RVD, we considered two systems--low-impact docking and grapple berthing. In docking, the HOPE can be collided at a speed of about 1 cm/s and docked with a grasping mechanism having three to four absorbers. In berthing, the HOPE can be kept about 1 meter apart, held with a grappling extension mechanism, and pulled in for docking. These two operations could be done automatically, in principal, with some commands. A transit response accompanying a failure in the docking phase can be done automatically in real time.

In the space station-RVD, berthing may be done with the space station-RMS. In such a case, the automation system is vital.

The above systems presuppose the use of more than one data-relay satellite and will be operated with the Type III system of a space operation data system (SODS) to be developed. The space station-RVD has no clear-cut space station interface now, and its detailed design must be further adjusted.

3. Outline of the Rendezvous/Docking Technology

The RVD will be executed with a "guidance control plus RVD" system, a mounting system of the HOPE, and with a ground operation system. Figure 2

shows the installation positions of main mounting equipment, and Figure 3 shows a configuration of the mounting system.

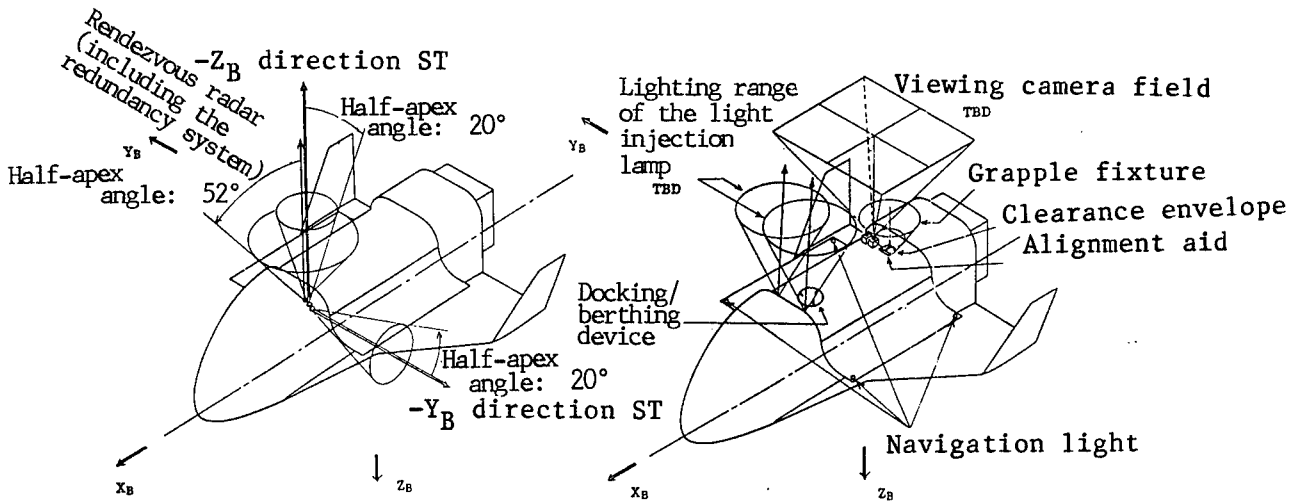

Figure 2. Installation Position of RVD-Mounted Equipment and Visual Field Characteristics

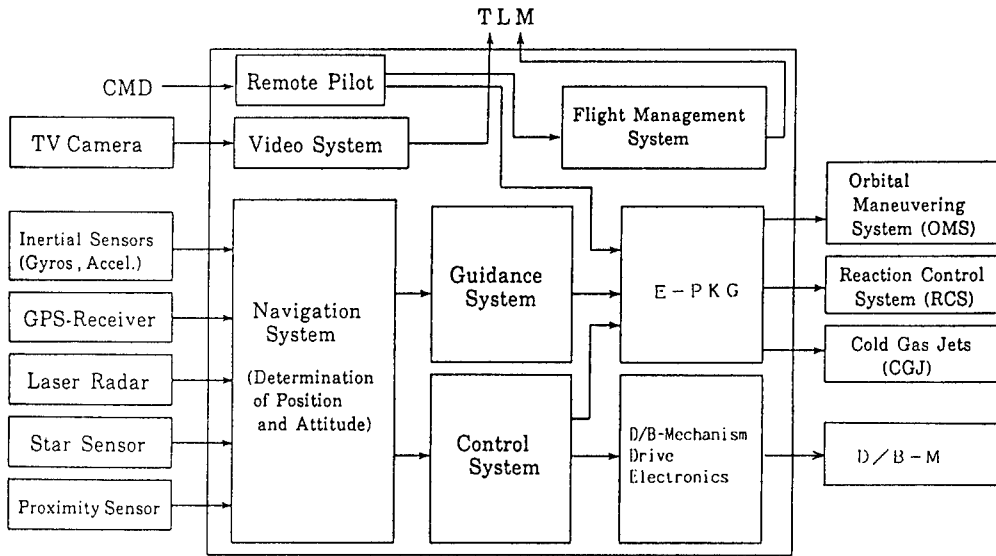

Figure 3. Block Diagram of the Mounting RVD System

The following roughly describes the contents of the major research and tasks of the mounting RVD system.³

(1) System technology

- Flight control: it controls mounted equipment and its software and executes controlling, monitoring, transferring, and resetting of the flight sequence, mode, and route, automatically or with support from the ground. Design of a switching algorithm to meet various situations and a verification method need to be established.

- Navigation method: in rendezvous navigation, there is an absolute navigation of the orbit adjustment phase and relative navigation after the relative approach. In particular, high-accuracy composite navigation, including transit characteristics, the navigation sensor, and the support interface up to the approach with dif-GPs and optical laser in the relative navigation, are important.

- Guidance: an automated targeting and guidance command will be executed based on the Hohmann/Lambert algorithm and Hill formula. The targeting cycle in correction maneuvers and detailed analyses of standard orbit, recovery, retreat, and avoidance guidance, which are described later, have to be tackled.

- Control: in contrast with a conventional satellite's attitude control technology, parallel proceeding and rotation of the (cold) RCS in the proximity zone are accurately controlled using a phase space control. An autopilot function in the proximity zone, bloom influence, analysis of the transit response, and sensor capacity have to be tackled, along with a docking/berthing control, such as the matching of contact conditions in docking.

(2) Equipment technology

- GPS receiver: in particular, highly accurate (a few meters, cm/s) relative navigation by the finite difference mode is required.

- Rendezvous radar: it is a 0.085μ continuous wave laser radar and a sensor to measure a range, range rate, and line of sight angle in the 2 meter to 20 km zone--a requisite sensor for automation of the proximity phase. It is important to design measurement and tracking section capacities and to develop interface designs and element technologies, including capacity improvement.

- Proximity sensor: this sensor measures the range and relative attitude in the 10 meter to several tens of meters zone. Basically, it will be achieved with a video camera plus data processing calculation, but one system using several points as the target and another using a specific pattern require further study.

- Docking mechanism: in the space station-RVD, a grapple fixture and berthing target to hold the space station-RMS, and a keel fitting for berthing are required. For the DO-RVD, we are manufacturing test elements of the mechanism capable of low-impact docking and grappling berthing. The docking system and mechanism have to be studied taking into account international compatibility.

To ensure safety and operability and perform RVD effectively with the above systems, design of a standard orbit and flight control method is important. With it, the RVD operation can be standardized.

Standard orbit is designed with the following composite requirements as the prerequisites: (1) ability to steadfastly execute safety control, (2) secure data relay satellite circuits, sunshine condition, and operability of recovery and retrieval, (3) compatible with the navigation guidance control system, and (4) effective required time and resource of thrust powder.

Flight control can be established by designing (1) mounting system redundancy, (2) onboard automated flight control, and (3) clarifying control functions of the ground operation system.

We have completed basic studies and are working on the main study, including verification methods.

The technology to accomplish ground operation control is a support technology for operators, with its real-time operation technology serving as the focal point. We have started on its basic study (it will be an objective for AI).

The remote control commanding technology has been under study for the final approach of space station-RVD and higher proximity work in the future. Further, we have been studying acceleration capacity related to MMI, a mounting system design such as optimization of the auto piloting function, and the ground command system.

4. Development of RVD System and Orbital Verification Test

The above RVD system knowhow will be regularly acquired with system tests on the ground and verification tests in orbit. Ground tests include a flight control test for automated and manned systems and a closed loop test for the proximity and docking phases. Orbital tests are for total confirmation of complicated systems, accumulation of data, and improvement of systems. Table 1 shows the need for element technology and orbital tests. At present, we are studying a TVD test for orbital tests, using an imaginary target and a subsatellite with the HOPE-TF#2, and a total RVD test for approaching the space station with the HOPE-TF#3.⁴

Table 1. Classification of RVD Technologies and Necessity of Orbital Experiments

A: Orbital experiments are required at the element technology level.
 B: Orbital experiments are required at the system technology level.
 C: Can be satisfactorily established with preprograms or tests on the ground.

A) Guidance/Control Sub-System Technology		Level
Automated Flight	<ol style="list-style-type: none"> 1. Mode control intrinsic to RVD 2. Automated wave-off control 3. Automated CAM control 	B
Navigation	<ol style="list-style-type: none"> 1. Inertia navigation 2. Composite navigation (position, speed) 3. Composite navigation (attitude) 	C
	<ol style="list-style-type: none"> 4. Relative navigation (position, speed) 5. Relative navigation (attitude, attitude rate) 	B
Guidance	<ol style="list-style-type: none"> 1. RV targeting 2. Coarse injection guidance 3. Fine injection guidance 4. Relative approach guidance 5. Relative position hold 6. Collision avoidance 7. Emergency refuge 8. Viewing 	B
	<ol style="list-style-type: none"> 1. Rendezvous launching (rocket) 	B
Control	<ol style="list-style-type: none"> 1. Parallel proceeding/rotation docking control 2. Thruster control logic 3. Relative control meeting blooms 4. Control adapting to change of characteristics 	B
	<ol style="list-style-type: none"> 1. Passive berthing 	C
Remote control	<ol style="list-style-type: none"> 1. Target search 2. Relative approach/hold 3. Fly-around 4. Proximity approach/viewing 5. Proximity stop 6. Collision avoidance/emergency refuge 	B

B) Equipment Technology

Level

Mounting computer	Functions corresponding to each technical item of a subsystem are executed in each phase.	B
Navigation equipment (sensors)	<ol style="list-style-type: none"> 1. GPS receiver (alone) 2. GPS receiver (difference) 3. Rendezvous radar 4. Star sensor 5. Approach sensor 	<p>C A A C B</p>
Equipment for remote control	<ol style="list-style-type: none"> 1. Viewing camera 2. Docking/berthing camera 3. Navigation light 4. Flood light 5. Visual ranging queue 	B
Guidance/control equipment	<ol style="list-style-type: none"> 1. Orbit control thruster (OMS) 2. Attitude control thruster (RCS) 3. Cold-gas jet (CGJ) 	<p>C C B</p>
Equipment and subsystem for berthing/docking	<ol style="list-style-type: none"> 1. General manipulator 2. Dedicated manipulator 3. Berthing target 4. Grapple fixture 5. FSS latch 6. FSS fixture 7. Sensor for automated docking 8. Docking/berthing mechanism 9. Keel hook 	<p>A A C C B B C A C</p>

C) Operational Control Technology

Level

Tracking control	<ol style="list-style-type: none"> 1. Decision of orbit (real time, sub-real time) 2. DRTS interface (dual) 3. System health check (real time) 4. Telemetry command management 5. Contingency control 	B
RVD mission control	<ol style="list-style-type: none"> 1. Flight management support <ul style="list-style-type: none"> - Flight plan, mission analysis - RVD scenario creation, re-creation - Flight safety, contingency control 2. Remote-distance guidance support <ul style="list-style-type: none"> - Rendezvous orbit information display (phase and altitude differences) 3. Near-distance guidance support <ul style="list-style-type: none"> - Position display on target coordinates - Emergency stop information - Calculation/display of flight safety control 4. Control support 	B
Remote control command/remote control operation	<ol style="list-style-type: none"> 1. Operation support system (arithmetic processing display) <ul style="list-style-type: none"> - Tele-presence, time-delay compensation 2. Operation system <ul style="list-style-type: none"> - Parallel proceeding/rotation operation (approach) - Berthing/docking operation - Emergency refuge/collision avoidance - Pilot training 	B
Control by space station	<ol style="list-style-type: none"> 1. Circuit interface (Space vehicle, ground station, DRTS, TDRS) 2. Operation/remote control by space station crew 	B

5. Conclusions

We have outlined the system concept, main technologies, and verification programs for RVD technology as a vital orbital technology. Further studies to develop and steadfastly acquire RVD technologies for an unmanned space vehicle, while exchanging information positively on the international common work, will continue.

References

1. W. G. Huber, et al., "Orbital Maneuvering Vehicle: New Capability," (IAF-87-194).
2. E S A S P-272, "1st European In-orbit Operation Technology," (1987).
3. H. Nakamura, et al., "Study of Autonomous Rendezvous and Docking," (JRS. winter '89).
4. I. Kawano, et al., "In-orbit Demonstration Concept for RVD," (IAF-89-017).

Current Status, Role of Flight Simulation Technology

906C3828J Tokyo HIKOKI SHINPOJIUMU in Japanese Oct 89 pp 60-63

[Article by Hirokazu Matsushima of the Aerospace Technology Lab: "Present Status and Role of Flight Simulation Technology"]

[Text] 1. Introduction

What does flight simulation mean in a broad sense? It is to analyze real situations and possibilities of a flight through a numerical or physical model as time lapses. On the basis of this thinking, I would like to introduce present technologies at our laboratory related to flight simulation and its role in developing space shuttles, including the HOPE, in the future.

2. Flight Simulation

In flight simulation, a real flight situation is reproduced as exactly as possible for accurate analyses (Figure 1).

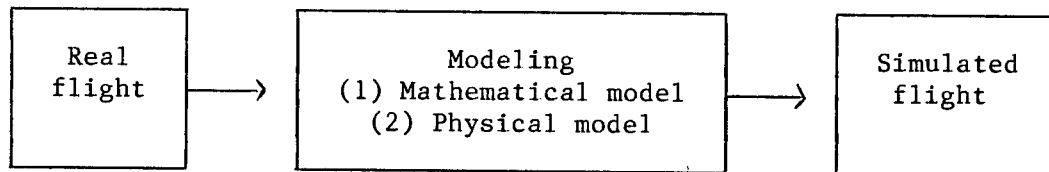

Figure 1. Flight Simulation

It is easy to imagine that a simple, low-cost flight simulation provides an effective means of developing an airframe. In fact, its role is becoming more important every year. In an aircraft, for example, the role of flight simulation can be used for tasks shown in Figure 2.

Simulation Utilization in Design/Development Stage

- Evaluation of flight characteristics.
- Evaluation of overall dynamic characteristics of airframe.
- Evaluation of navigation/guidance/control system.
- Evaluation of piloting system.
- Evaluation of things related to avionics.
- Pre-evaluation when designs are changed.
- Evaluation in emergency and contingency.
- Flight training.

Figure 2. Roles of Flight Simulation in Aircraft Development

Flight simulation is able to play these roles because real flight situations and unlikely possibilities are freely included in "a real-flight" frame.

For example, the following can be included:

- Generation of special troubles.
- Sequence conversion or partial generation of consecutive events.
- Creation of abstract events.
- Free setting of time length.

With these settings, a very effective test covering various trouble in a short time, execution of a landing phase without a take-off phase, and realization of longitudinal movement only.

I consider some effective uses of this simulation technology in view of the innovative technological challenges in fields where Japan has little experience, including such space shuttle developments as the HOPE.

The following four flight simulations will be described more in detail (Figure 3).

- (1) Simulation by an experimental aircraft.
- (2) Ground flight simulation.
- (3) Digital simulation.
- (4) Wind tunnel simulation using a dynamic model.

As shown in Figure 3, the first simulation is realized in a real environment through an experimental aircraft of FBW system by modifying rudder steering quantity and response parameters of its pilot and by altering the seeming stability of its airframe and control response. This poses the most reality with a nervous moment, but simulation range is limited to the operation range of an aircraft. In contrast, the second simulation is realized as the pilot physically feels through a cockpit installed on the ground based on movements obtained from the computer. The accuracy of a numerical model and the movement function of a cockpit are therefore, always problematical. However, simulation range can be made considerably wider than that of the first simulation when environmental conditions and the external line of sight are

set wider. The third simulation allows a very wide range of simulations, along with rapid development of computers, accurate numerical models, and numerical analysis methods. Its applications are varied but generally its effect is reinforced by concurrently using a physical model. The fourth simulation has a big problem in its similarity with a target airframe when a subscale model is used to evaluate its results, but it is very interesting for forthcoming tasks because it is possible to develop into a free flight test using a real environment.

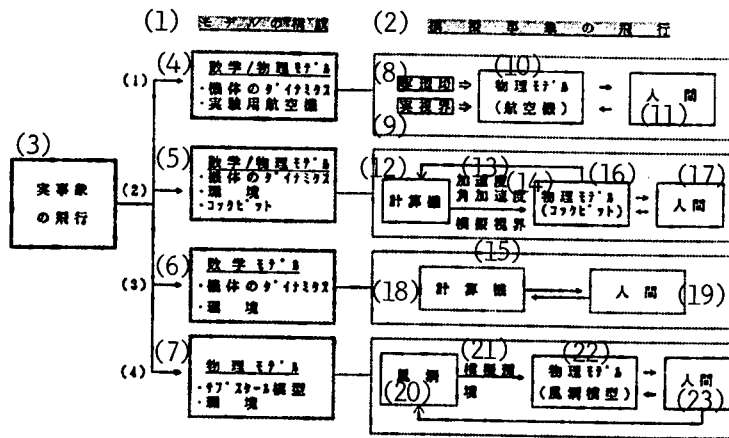

Figure 3. Conceptual Diagram of Four Flight Simulations

Key:

- | | |
|---------------------------------------|--|
| 1. Model configuration | 8. Real environment |
| 2. Simulated flight | 9. Real line of sight |
| 3. Real flight | 10. Physical model (aircraft) |
| 4. <u>Numerical/physical model</u> | 11. Human |
| - Dynamics of the airframe | 12. Computer |
| - Experimental aircraft | 13. Acceleration |
| 5. <u>Mathematical/physical model</u> | 14. Angle acceleration |
| - Dynamics of the airframe | 15. Simulated line of sight |
| - Environment | 16. Physical model (cockpit) |
| - Cockpit | 17. Human |
| 6. <u>Mathematical model</u> | 18. Computer |
| - Dynamics of the airframe | 19. Human |
| - Environment | 20. Wind tunnel |
| 7. <u>Physical model</u> | 21. Simulated environment |
| - Subscale model | 22. Physical model (wind tunnel model) |
| - Environment | 23. Human |

There four simulations are deemed to be typical models for a wide variety of flight simulations and are categorized as shown in Figure 4. A flight simulation uses a model to be simulated either in a real or simulated environment and a similar equivalent situation is realized. However, though similar in equivalence, human sense plays a vital factor when the simulation is realized through a human, and it is not necessarily physically equivalent. Therefore, a simulation is varied in its content, depending on its means. Its features ease in analyzing a study target, in execution, and in safety. To make the most of these features is a basis for selecting a particular simulation.

3. Present Status of the Flight Simulation Studies at the Space Technology Laboratory

3.1 Status of Each Simulation Study

Figure 5 shows details and presents the status of the four simulations described earlier.

3.2 Applications to HOPE R&D

Simulators for each simulation are often big structures or have specialty functions suited for each purpose, resulting in a problem in smoothing out that gap when existent structures are used for a new task. Using a Do-228 plane as an example, the following describes how to solve this problem for some tasks in the A/L phase for airframe flying at a high speed, like the HOPE. The tasks to be solved are how to simulate its speed, lowering angle, and attitude. Details are given below.

Type	Model to be Simulated	Simulated Flight Environment	Operator of Simulation	Simulation
(1)	Mathematical model and physical model	Real environment	Human*	- In-flight simulation
			Machine**	- Navigational test - Auto landing test
(2)		Mathematical simulated environment	Human*	- Ground flight simulation
(3)	Mathematical model	Mathematical simulated environment	Machine**	- Digital simulation
(4)	Physical model	Physical simulated environment	Machine**	- Dynamic wind tunnel test

* Human: a simulated situation is realized through human senses. (The final flight simulation is realized by a physical model but is a composite of senses for human movements and visual information, not necessarily a simulation of dynamics.)

** Machine: a simulated situation is realized through measurement instruments and computers. (The final flight simulation is a simulation of dynamics in a real situation.)

Figure 4. Classification of Flight Simulations

Simulation	Equipment and Functions	Study Target	Current Work
(1) In-flight simulation	<p>-DORNIER 228-200 (experimental aircraft)</p> <p>Overall length: 16.56 meters</p> <p>Overall width: 16.97 meters</p> <p>Overall height: 4.86 meters</p> <p>Wing area: 32.00 m²</p> <p>Passenger room capacity: 14.70 m²</p> <p>Number of seats: 19</p> <p>Standard empty weight: 3,202 kg</p> <p>Max. take-off weight: 5,700 kg</p> <p>Max. cruising speed: 370 km/h (overseas)</p> <p>-Fiber wiring of the simulated cockpit and VSRA of airframe are under study now</p>	<p>Targetting at A/L phase:</p> <p>-Evaluation of navigation sensor/ system</p> <p>-Evaluation of navigation system's functions/ reliability</p> <p>-Evaluation of auto landing system</p> <p>-Evaluation of remote control command system</p>	<p>-Evaluation test of navigation sensor</p> <p>-Evaluation test of composite navigation system^{1,2}</p>
(2) Ground-flight simulation	<p>-General-purpose flight simulator equipment</p> <p>Configuration:</p> <p>(1) Simulated pilot seat (for large transport aircraft)</p> <p>(2) External line of sight simulator (CGI format)</p> <p>(3) Motion simulator (8-free-degree, variable range up to ±1 meter parallel proceeding, ±30° rotation, ±1 g acceleration)</p> <p>(4) Flight movement computing (32-bit super minicon, etc.)</p> <p>-Simple pilot seat for space shuttle is under study.</p>	<p>-Evaluation of flight performance, command and safety</p> <p>-Evaluation of auto landing system</p> <p>-Evaluation of remote control command system</p> <p>-Evaluation of cockpit/remote control command table</p> <p>-Evaluation of flight experiments</p>	<p>-Simulation test of A/L phase simulating STS orbiter³</p> <p>-Structure of pilot seat for shuttles</p> <p>-Establishment of remote control piloting</p>

(3) Digital simulation	<p>Two representative examples are shown here (except CFD-related one)</p> <ul style="list-style-type: none"> -Space plane navigation simulator: Orbit creation and navigation system simulation of all phases from SP take-off, lift up, orbiting, reentry to landing. <p>Configuration:</p> <ul style="list-style-type: none"> (1) SP lift up/lowering phase status vector creation (2) Creation of multi-satellite orbits (SP/GPS/TDRSS data) (3) Navigation system simulations (measurement model/assumed model) <p>SP conceptual design support system: Design analysis support system capable of integrating composite analyses and input/output data, using intelligent processing techniques</p> <p>Configurations:</p> <ul style="list-style-type: none"> (1) Linked operation of each element technology program (2) Structuring database for design analyses 	<ul style="list-style-type: none"> -Evaluation of navigation system in all flight phases -Evaluation of safety controllability of hyper/supersonic flight -Operation analysis on orbit -Evaluation of guidance control system from reentry to landing -Evaluation of other simulation experiments -Evaluating interactive functions of each element technology -Evaluating SP conceptual designs and study tasks 	<ul style="list-style-type: none"> -Evaluation of navigation systems using GPS from reentry to A/L phase⁶ -Evaluation and concept designs based on flight simulation of thrust aerodynamic characteristics and materials⁷
------------------------	---	---	---

<p>(4) Wind tunnel simulation using dynamic models</p>	<p>-Wind tunnels capable of dynamic tests Large low-speed wind tunnel: measurement section; 8.5 m x 5.5 m test speed; 60 m/s or less transonic wind tunnel: measurement section; 2 m x 2 m test speed; 0.1 ~ 1.4 (Mach) -Proceeding from the cable mount method to automated flight is under study</p>	<p>-Measuring dynamic aerodynamic characteristics of SP model -Evaluating guidance control rules -Establishing dynamic wind tunnel test -Studying remote control piloting technology -Establishing free flight test technology -Establishing ACT technology</p>	<p>-Dynamic test based on the cable mount method using SP models⁴ -Active control technology test using all elastic models⁵</p>
--	---	--	--

Speed Problem

In a simulation of the approach phase, the length scales are conformed to and the time scale rate of an experiment plane for the HOPO is set to 1 to k . For example, when a navigation filter is tested, the following settings are conceivable in inputting sensor output of the experimental plane to the filter system:

Position/attitude angle sensor output \rightarrow as it is.
Speed/angular speed sensor output $\rightarrow k$ times.
Output of the acceleration sensor $\rightarrow k^2$ times.
Clock frequency of the navigation filter computer $\rightarrow 1/k$ times.
Gravity acceleration $g \rightarrow k^2$ times.

When approach speeds of the HOPE and the experimental plane are compared, the ratio is $k \sim 2$. To what range of a k value the above assumption is applicable depends, in part, on the dynamic range of each sensor.

Lowering Angle Problem

The maximum possible lowering angle depends on airframe L/D. What is allowed for Do-228 is about 10 degrees ($V_{EAS} = 120$ kt, deepest flap angle with lowered legs). To raise it to 20 degrees of the HOPE, it is necessary to increase D with a drag generator of a reverse thrust (not easy because both have limitations).

If only the lowering angle is considered, however, a simple means of acceleration flight with constant route angle is possible (Figure 6). In numerical calculation with τ at -20° , H was obtained at 1,400 (ft). ($V_1 = 90$ kt, $V_2 = 180$ kt, clean configuration).

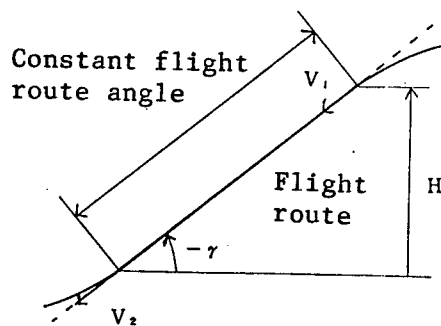

Figure 6. Trajectory of Constant Route Angle Flight

Altitude Correction

When a simulation is conducted in a flare, simulating longitudinal attitude change of the HOPE for an extremely small $C_L \alpha$ using a Do-228 plane definitely needs a facility like DLC. However, when a navigational system test like an inertia sensor is made, quite a lot can be achieved by installing a test stand supported by a gimbal in the plane.

4. Conclusions

A flight simulation, when its application purpose is R&D (not training), is just enough if the simulated situation is partly equivalent to the real situation. Therefore, what is needed is a simulation suited as much as possible to understanding the substance of the real target. Further, its execution must be easy, safe, and inexpensive. In another sense, it is possible to effectively use existing facilities and experience for the study target.

References

1. Ono, Sakai, Uchida, Kamata: Present Status and Flight Test of Experimental Aircraft Dornier Do-228 (Report scheduled at the 27th Aircraft Symposium).
2. Ono, Uchida, Kawahara, Matsushima, Ishikawa, Murata, Shingu: Study on the Differential GPS with Flight Experiments (Report scheduled at the 27th Aircraft Symposium).
3. Ono, Uchida, Kawahara, Wakairo, Kawamura, Fukutome, Yutaka, Makino: Tests and Studies on Space Plane Flight Simulator (Report scheduled at the 27th Aircraft Symposium).
4. Suzuki, Terui, Murota, Kondo, Nagayasu, et al.: Preliminary Dynamic Wind Tunnel Test of Space Plane with Cable Mount (Report scheduled at the 27th Aircraft Symposium).
5. Matsushita, Miyazawa, Kikuchi, Suzuki, Ueda, et al.: Wind Tunnel Test of Gust Load for All Elastic Model (1st Report) (Report scheduled at the 27th Aircraft Symposium).
6. Murata, Matsushima, Shigu, Yanagihara, Sanke, Shimizu, Yoshikawa: Preliminary Analysis of Space Plane, 5th Aerospace Guidance Control Symposium References, Measurement Automated Control Society, Nov., 1988.
7. Yamamoto, Naka, Harada, et al.: Conceptual Design Support System of Space Shuttle (33rd Space Science Technological Association Symposium).

- END -

22161

45

NTIS
ATTN: PROCESS 103
5285 PORT ROYAL RD
SPRINGFIELD, VA

22161

This is a U.S. policies, views, or attitudes of the U.S. Government. Users of this publication may cite FBIS or JPRS provided they do so in a manner clearly identifying them as the secondary source.

Foreign Broadcast Information Service (FBIS) and Joint Publications Research Service (JPRS) publications contain political, military, economic, environmental, and sociological news, commentary, and other information, as well as scientific and technical data and reports. All information has been obtained from foreign radio and television broadcasts, news agency transmissions, newspapers, books, and periodicals. Items generally are processed from the first or best available sources. It should not be inferred that they have been disseminated only in the medium, in the language, or to the area indicated. Items from foreign language sources are translated; those from English-language sources are transcribed. Except for excluding certain diacritics, FBIS renders personal and place-names in accordance with the romanization systems approved for U.S. Government publications by the U.S. Board of Geographic Names.

Headlines, editorial reports, and material enclosed in brackets [] are supplied by FBIS/JPRS. Processing indicators such as [Text] or [Excerpts] in the first line of each item indicate how the information was processed from the original. Unfamiliar names rendered phonetically are enclosed in parentheses. Words or names preceded by a question mark and enclosed in parentheses were not clear from the original source but have been supplied as appropriate to the context. Other unattributed parenthetical notes within the body of an item originate with the source. Times within items are as given by the source. Passages in boldface or italics are as published.

SUBSCRIPTION/PROCUREMENT INFORMATION

The FBIS DAILY REPORT contains current news and information and is published Monday through Friday in eight volumes: China, East Europe, Soviet Union, East Asia, Near East & South Asia, Sub-Saharan Africa, Latin America, and West Europe. Supplements to the DAILY REPORTs may also be available periodically and will be distributed to regular DAILY REPORT subscribers. JPRS publications, which include approximately 50 regional, worldwide, and topical reports, generally contain less time-sensitive information and are published periodically.

Current DAILY REPORTs and JPRS publications are listed in *Government Reports Announcements* issued semimonthly by the National Technical Information Service (NTIS), 5285 Port Royal Road, Springfield, Virginia 22161 and the *Monthly Catalog of U.S. Government Publications* issued by the Superintendent of Documents, U.S. Government Printing Office, Washington, D.C. 20402.

The public may subscribe to either hardcover or microfiche versions of the DAILY REPORTs and JPRS publications through NTIS at the above address or by calling (703) 487-4630. Subscription rates will be

provided by NTIS upon request. Subscriptions are available outside the United States from NTIS or appointed foreign dealers. New subscribers should expect a 30-day delay in receipt of the first issue.

U.S. Government offices may obtain subscriptions to the DAILY REPORTs or JPRS publications (hardcover or microfiche) at no charge through their sponsoring organizations. For additional information or assistance, call FBIS, (202) 338-6735, or write to P.O. Box 2604, Washington, D.C. 20013. Department of Defense consumers are required to submit requests through appropriate command validation channels to DIA, RTS-2C, Washington, D.C. 20301. (Telephone: (202) 373-3771, Autovon: 243-3771.)

Back issues or single copies of the DAILY REPORTs and JPRS publications are not available. Both the DAILY REPORTs and the JPRS publications are on file for public reference at the Library of Congress and at many Federal Depository Libraries. Reference copies may also be seen at many public and university libraries throughout the United States.