

NAVAL POSTGRADUATE SCHOOL
Monterey, California



THESIS

**INTEGRATION OF COMMERCIAL MOBILE SATELLITE
SERVICES INTO NAVAL COMMUNICATIONS**

by

Cary Reese Stone

September, 1997

Thesis Advisor:
Second Reader:

Brij Agrawal
Donald v. Z. Wadsworth

Approved for public release; distribution is unlimited

19980212 093

DTIC QUALITY INSPECTED 4

REPORT DOCUMENTATION PAGE

Form Approved
OMB No. 0704-0188

Public reporting burden for this collection of information is estimated to average 1 hour per response, including the time for reviewing instruction, searching existing data sources, gathering and maintaining the data needed, and completing and reviewing the collection of information. Send comments regarding this burden estimate or any other aspect of this collection of information, including suggestions for reducing this burden, to Washington headquarters Services, Directorate for Information Operations and Reports, 1215 Jefferson Davis Highway, Suite 1204, Arlington, VA 22202-4302, and to the Office of Management and Budget, Paperwork Reduction Project (0704-0188) Washington DC 20503.

1. AGENCY USE ONLY (Leave blank)		2. REPORT DATE September 1997	3. REPORT TYPE AND DATES COVERED Master's Thesis	
4. TITLE AND SUBTITLE Integration of Commercial Mobile Satellite Services into Naval Communications			5. FUNDING NUMBERS	
6. AUTHOR(S) Stone, Cary Reese				
7. PERFORMING ORGANIZATION NAME(S) AND ADDRESS(ES) Naval Postgraduate School Monterey, CA 93943-5000			8. PERFORMING ORGANIZATION REPORT NUMBER	
9. SPONSORING / MONITORING AGENCY NAME(S) AND ADDRESS(ES)			10. SPONSORING/MONITORING AGENCY REPORT NUMBER	
11. SUPPLEMENTARY NOTES The views expressed in this thesis are those of the author and do not reflect the official policy or position of the Department of Defense or the U.S. Government.				
12a. DISTRIBUTION / AVAILABILITY STATEMENT Approved for public release; distribution is unlimited.			12b. DISTRIBUTION CODE	
<p>ABSTRACT (maximum 200 words)</p> <p>Mobile Satellite Services (MSS) need to be integrated into Naval Communications. DoD SATCOM military-owned systems fall well short of meeting DoD SATCOM requirements in general and mobile SATCOM specifically. This thesis examines DoD SATCOM requirements, especially those affecting communications on the move. From these requirements, three systems -- Inmarsat, Iridium and Globalstar -- are identified and evaluated for potential use in Naval Communications. An overview of space communications and each of the three systems is provided to identify general operational capabilities, system strengths and system weaknesses. The Naval narrowband functional requirements process is explored and DoD SATCOM and Commercial MSS ability to satisfy those requirements is assessed. Potential Naval MSS communications missions are examined and possible DoD enhancements are considered for each system as well as the impact these enhancements will have on each system. Recommendations are provided as to which Naval communications missions are best suited for these enhanced MSS.</p>				
14. SUBJECT TERMS MSS, PCS, Naval Narrowband Functional Requirements, Space Communications, Inmarsat, Iridium, Globalstar, DoD SATCOM, LEO, MEO, GEO			15. NUMBER OF PAGES 168	
			16. PRICE CODE	
17. SECURITY CLASSIFICATION OF REPORT Unclassified	18. SECURITY CLASSIFICATION OF THIS PAGE Unclassified	19. SECURITY CLASSIFICATION OF ABSTRACT Unclassified	20. LIMITATION OF ABSTRACT UL	

NSN 7540-01-280-5500

Form 298 (Rev. 2-89)

Standard

by ANSI Std. Z39-18

Prescribed

Approved for public release; distribution is unlimited

**INTEGRATION OF COMMERCIAL MOBILE SATELLITE SERVICES
INTO NAVAL COMMUNICATIONS**

Cary Reese Stone
Lieutenant, United States Navy
B.S., University of Mississippi, 1992

Submitted in partial fulfillment of the
requirements for the degree of

MASTER OF SCIENCE IN SPACE SYSTEMS OPERATIONS

from the

**NAVAL POSTGRADUATE SCHOOL
September 1997**

Author: 
Cary Reese Stone

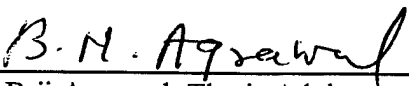
Approved by: 
Brij Agrawal, Thesis Advisor

Donald v. Z. Wadsworth, Second Reader

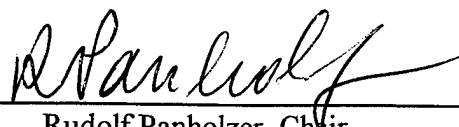
Rudolf Panholzer, Chair,
Space Systems Academic Group

ABSTRACT

Mobile Satellite Services (MSS) need to be integrated into Naval Communications. DoD SATCOM military-owned systems fall well short of meeting DoD SATCOM requirements in general and mobile SATCOM specifically. This thesis examines DoD SATCOM requirements, especially those affecting communications on the move. From these requirements, three systems -- Inmarsat, Iridium and Globalstar -- are identified and evaluated for potential use in Naval Communications. An overview of space communications and each of the three systems is provided to identify general operational capabilities, system strengths and system weaknesses. The Naval narrowband functional requirements process is explored and DoD SATCOM and Commercial MSS ability to satisfy those requirements is assessed. Potential Naval MSS communications missions are examined and possible DoD enhancements are considered for each system as well as the impact these enhancements will have on each system. Recommendations are provided as to which Naval communications missions are best suited for these enhanced MSS.

TABLE OF CONTENTS

I.	INTRODUCTION.....	1
A.	BACKGROUND.....	1
B.	PURPOSE	4
C.	ORGANIZATION	4
1.	Chapter II. Naval Narrowband Functional Requirements.....	4
2.	Chapter III. Overview of Commercial Mobile Satellite Services ..	4
3.	Chapter IV. Integration of Commercial Mobile Satellite Services into Naval Communications Architecture	5
4.	Chapter V. Conclusions and Recommendations.....	5
II.	NAVAL NARROWBAND FUNCTIONAL REQUIREMENTS.....	7
A.	NAVAL OPERATIONS	7
1.	Forward ...From the Sea	7
2.	Peacetime Forward Presence Operations.....	7
3.	Naval Operations -- Other than War.....	8
4.	Sealift	9
5.	Naval Operations in War.....	9
6.	Joint Operations	10
B.	DOD SATCOM FUNCTIONAL REQUIREMENTS DOCUMENT	11
1.	Requirements Databases	11
2.	Requirements Characteristics and Functional Areas.....	12
3.	Operational Deployment Scenarios.....	14
a.	<i>Peacetime Scenario</i>	15

b.	<i>Combined Major Regional Conflict Scenario (CMRC)</i>	15
c.	<i>Multiple Lesser Regional Conflict Scenario (MLRC)</i>	16
4.	Capacity Estimates.....	17
a.	<i>Composite Capacity</i>	17
b.	<i>Highly Protected Capacity</i>	18
c.	<i>Protected Capacity</i>	19
d.	<i>Minimally Protected Capacity</i>	20
e.	<i>Terminal Capacity</i>	20
C.	DOD SATCOM SYSTEM LIMITATIONS	21
1.	Replenishment of DoD-Owned Capability	22
2.	Connectivity	23
3.	Protection.....	24
4.	Access and Control.....	24
5.	Interoperability	25
6.	Flexibility.....	25
7.	Quality of Service	26
D.	MOBILE USER STUDY REQUIREMENTS (MUS) WORKING INTEGRATED PRODUCT TEAM (WIPT)	26
1.	MUS WIPT Overview	27
2.	MUS WIPT Requirements	27
3.	MSS Satisfying MUS WIPT Requirements	28
E.	SELECTION OF MSS FOR FURTHER STUDY	29
F.	DOD UHF SYSTEMS VS MSS	30

III.	OVERVIEW OF COMMERCIAL MOBILE SATELLITE SERVICES.....	33
A.	SPACE COMMUNICATIONS.....	33
1.	Space Segment.....	33
2.	Ground Segment.....	37
3.	Multiple Access Methods.....	38
a.	<i>Frequency Division Multiple Access (FDMA)</i>	39
b.	<i>Time Division Multiple Access (TDMA)</i>	40
c.	<i>Code Division Multiple Access (CDMA)</i>	41
B.	INMARSAT.....	43
1.	System Overview.....	43
a.	<i>Space Segment</i>	44
b.	<i>Ground Segment</i>	47
2.	System Strengths.....	51
3.	System Weaknesses.....	54
C.	IRIDIUM.....	56
1.	System Overview.....	56
a.	<i>Space Segment</i>	58
b.	<i>Ground Segment</i>	62
2.	System Strengths.....	66
3.	System Weaknesses.....	67
D.	GLOBALSTAR.....	70
1.	System Overview.....	70

a.	<i>Space Segment</i>	73
b.	<i>Ground Segment</i>	77
2.	System Strengths	83
3.	System Weaknesses	86
IV.	INTEGRATION OF COMMERCIAL MOBILE SATELLITE SERVICES INTO NAVAL COMMUNICATIONS	89
A.	MSS POTENTIAL NAVAL COMMUNICATIONS MISSIONS	89
1.	Polar Communications	90
2.	VIP/Flag Communications	91
3.	GBS Orderwire Communications	92
4.	Combat Search and Rescue (CSAR) Communications	93
5.	Command and Control (C2) of Tactical Forces Communications	94
6.	Maritime Operations Command Communications	95
7.	Special Operations Communications	96
8.	Naval Surface Fire Support (NSFS) Ship-to-Shore Communications	97
9.	Logistics Support Communications	98
10.	Moral Support Communications	99
11.	Peace Keeping and Humanitarian Operations Communications ..	100
12.	Military Support to Civilian Authorities Communications	101
B.	POTENTIAL DOD ENHANCEMENTS TO COMMERCIAL MOBILE SATELLITE SERVICES	102
1.	Inmarsat	102
2.	Iridium	104

3.	Globalstar	108
C.	DOD UHF SYSTEMS AND DOD-ENHANCED MSS ABILITY TO SATISFY DOD/NAVAL REQUIREMENTS	111
D.	INTEGRATION OF INMARSAT INTO NAVAL COMMUNICATIONS	113
E.	INTEGRATION OF IRIDIUM INTO NAVAL COMMUNICATIONS	115
F.	INTEGRATION OF GLOBALSTAR INTO NAVAL COMMUNICATIONS.....	119
V.	CONCLUSIONS AND RECOMMENDATIONS.....	123
A.	CONCLUSIONS.....	123
B.	RECOMMENDATIONS	125
	APPENDIX A. UHF SATCOM'S ABILITY TO SATISFY MRC REQUIREMENTS	127
	APPENDIX B. ACRONYMS	131
	APPENDIX C. GLOSSARY.....	135
	LIST OF REFERENCES	139
	INITIAL DISTRIBUTION LIST	143

LIST OF FIGURES

Figure 2-1. Current MILSATCOM Life Expectancy	22
Figure 3-1. Typical GEO Satellite Coverage Area.....	34
Figure 3-2. Numerous LEO Coverage Areas within GEO Footprint.....	35
Figure 3-3. Frequency Division Multiple Access	40
Figure 3-4. Time Division Multiple Access	41
Figure 3-5. Code Division Multiple Access	42
Figure 3-6. FDMA, TDMA and CDMA in the Time-Frequency Plane.....	43
Figure 3-7. Inmarsat Satellite Coverage Areas	45
Figure 3-8. Inmarsat III Spot Beams.....	46
Figure 3-9. Inmarsat A and B Standard Configuration.....	49
Figure 3-10. Comsat Fiber Relay Network.....	53
Figure 3-11. Overview of Iridium System	58
Figure 3-12. Iridium Instantaneous Coverage Areas.....	59
Figure 3-13. Iridium Satellite Constellations.....	59
Figure 3-14. Iridium Satellite	60
Figure 3-15. Iridium Satellite Links.....	61
Figure 3-16. Iridium Handheld Phone and Pager	64
Figure 3-17. How Iridium Handles a Handset to PSTN Phone Call	65
Figure 3-18. Globalstar System Architecture.....	73
Figure 3-19. Globalstar Satellite Architecture	74
Figure 3-20. Globalstar's Satellite Orbital Paths.....	75

Figure 3-21. Globalstar's Satellite Coverage	76
Figure 3-22. Globalstar's Frequency Plan	77
Figure 3-23. Globalstar's Data Network	78
Figure 3-24. Artist Conception of a Globalstar Gateway	80
Figure 3-25. Globalstar's Personal Subscriber Units	81
Figure 3-26. Globalstar's Registration and Authentication Procedure	82
Figure 3-27. Globalstar's Billing Procedure	83
Figure 3-28. Globalstar's Path Diversity	85
Figure 4-1. Inmarsat Naval Communications Missions	115
Figure 4-2. Iridium Naval Communications Missions	119
Figure 4-3. Globalstar Naval Communications Missions	122

LIST OF TABLES

Table 1-1. Other Mobile Satellite Services Providers	3
Table 2-1. Operational Threats and Mitigation Techniques	14
Table 2-2. CMRC Force Structure	16
Table 2-3. MLRC Force Structure	16
Table 2-4. CMRC/MLRC Force Structure Comparison	16
Table 2-5. Narrowband Composite Capacity (2005-2010)	17
Table 2-6a. Narrowband Highly Protected Capacity (2005-2010)	18
Table 2-6b. Highly Protected Capacity Break-out (2005-2010)	18
Table 2-7a. Narrowband Protected Capacity (2005-2010)	19
Table 2-7b. Protected Capacity Break-out (2005-2010)	19
Table 2-8. Narrowband Minimally Protected Capacity (2005-2010)	20
Table 2-9a. Narrowband (Netted) Capacity by Terminal (2005-2010)	21
Table 2-9b. Narrowband (Point to Point) Capacity by Terminal (2005-2010)	21
Table 2-10. DoD SATCOM UHF Unfulfilled Requirements	24
Table 2-11. Required Capabilities Voting Results	28
Table 2-12. MSS Ability to Satisfy Required Capabilities	28
Table 2-13. Reasons for MSS Exclusion	30
Table 2-14. Using MSS WIPT Requirements to compare DoD UHF Systems & MSS	31
Table 3-1. Satellite Subsystems	33
Table 3-2. Free Space Loss for a GEO and LEO Satellite	36
Table 3-3. Radio Frequency Bands Used for Satellite Communications	37

Table 3-4. Ground Segment Terminals.....	38
Table 3-5. Access Method Advantages and Disadvantages.....	39
Table 3-6. Inmarsat III Characteristics	47
Table 3-7. Inmarsat A and B SES services	48
Table 3-8. Navy Requirements Satisfied by Inmarsat.....	54
Table 3-9. Inmarsat A and B Service Costs.....	55
Table 3-10. Iridium Satellite Frequency Bands	62
Table 3-11. Example of Iridium Costs for Netted Communications	68
Table 3-12. Strategic Partners System Component Responsibilities	71
Table 3-13. Gateway Features.....	79
Table 3-14. Example of Globalstar Costs for Netted Communications.....	86
Table 4-1. MSS Mission Requirements Defined	90
Table 4-2. Polar Communications Mission Requirements	91
Table 4-3. VIP/Flag Communications Mission Requirements	92
Table 4-4. GBS Orderwire Communications Mission Requirements	93
Table 4-5. CSAR Communications Mission Requirements	94
Table 4-6. C2 Tactical Forces Communications Mission Requirements	95
Table 4-7. Maritime Operations Command Communications.....	96
Table 4-8. Special Operations Communications.....	97
Table 4-9. NSFS Ship-to-Shore Communications.....	95
Table 4-10. Logistics Support Communications	99

Table 4-11. Morale Support Communications 100

Table 4-12. Peace Keeping and Humanitarian Operations..... 101

Table 4-13. Military Support to Civilian Authorities..... 102

Table 4-14. Inmarsat versus DoD-enhanced Inmarsat..... 104

Table 4-15. Iridium versus DoD-enhanced Iridium..... 108

Table 4-16. Globalstar versus DoD-enhanced Globalstar..... 111

Table 4-17. DoD UHF Systems versus DoD-enhanced MSS in satisfying DoD/Naval Functional Requirements 113

EXECUTIVE SUMMARY

Current DoD Satcom Systems cannot deliver sufficient UHF services to support today's widely dispersed mobile forces information intensive needs. By utilizing existing and soon-to-be-realized commercial MSS capabilities, information flow to the Navy's highly mobile and dispersed forces can be greatly increased. Comparing Naval Space Command's SATCOM Functional Requirements Document's requirements for a Naval force operating in a one-MRC scenario to UFO's capacity, Iridium's capacity and Globalstar's capacity highlights the potential gains in overall UHF communications capacity that can be gained by integrating commercial MSS. The figure below depicts the orders of magnitude of additional, untapped, commercial MSS capacity that can go a long way to satisfying existing as well unforeseen UHF communications requirements.

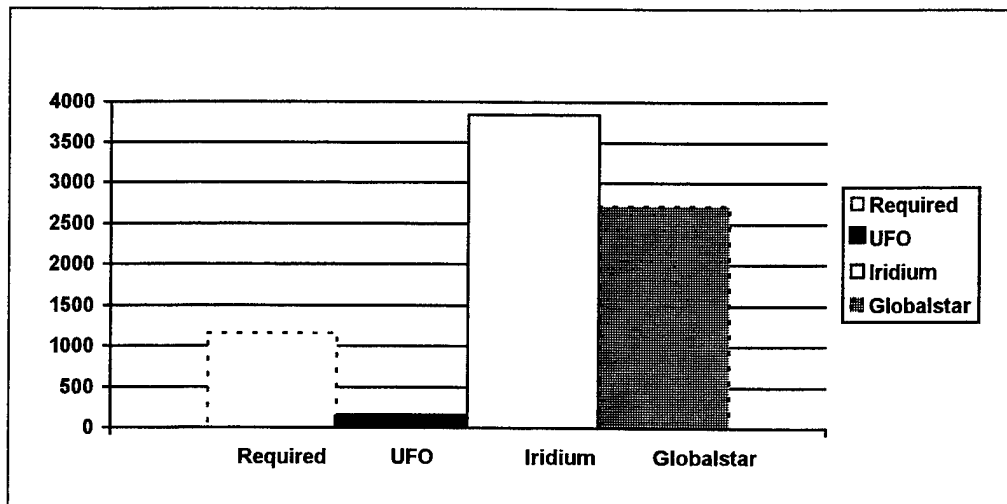

Naval One-MRC UHF Requirements Versus UFO, Iridium and Globalstar Capacities

The three commercial MSS which provide the greatest potential for integration into Naval communications are Inmarsat, Iridium and Globalstar. Inmarsat is already

integrated into half the fleet with the remaining half to have Inmarsat capability by the end of FY 97 and can provide Naval ships with up to 64 kbps communications connectivity. Iridium will be the first to market to provide cellular phone like satellite service and the only MSS to provide crosslinks between its satellites giving it truly world-wide communications capabilities. Globalstar will soon follow Iridium to market and has advantages in its use of CDMA technologies which will provide greater signal security as well as better operating characteristics in a tactical environment.

DoD enhancements will be necessary to increase the utility of integrating these three commercial MSS into Naval communications. DoD enhancements will take the form of contractual and technical techniques. These enhancements are necessary to satisfy requirements which are unique to military communications such as assured access and secure communications. Possible DoD enhancements for Inmarsat, Iridium and Globalstar are summarized in the table below.

MSS	Potential DoD Enhancements
Inmarsat	<ul style="list-style-type: none"> • STU III and KG-84 - secure communications. • Contracting a lease for transponders - increase assured access.
Iridium	<ul style="list-style-type: none"> • DoD gateway - increases call security, potential for netted service and improves assured access among DoD users. • Condor an NSA developed STU III device - secure communications. • Integration of GPS and Microburst technology - CSAR missions and remote sensor reporting. • Use of highly directional antenna - strategic and polar operations. • Contracting - priority preference, guaranteed call access and a surge provision - increase assured access.
Globalstar	<ul style="list-style-type: none"> • Combination of fixed and transportable DoD Gateway - increases call security and assured access among DoD users. • Condor an NSA developed STU III device - secure communications. • Integration of GPS and Microburst technology - CSAR missions and remote sensor reporting. • Group Services - enable broadcast and networking capabilities. • Contracting - priority preference, guaranteed call access and a surge provision - increase assured access.

Each of the DoD-enhanced MSS under discussion provide certain characteristics which make them attractive for certain missions with some mission overlap. DoD-enhanced Inmarsat provides Naval forces afloat with a larger two-way data rate capability which can be used for bandwidth-intensive functions such as BDA, GCCS, and Tomahawk MDU. Additionally, Inmarsat can support multiple, lower-data-rate services such as SALTS, multiple secure phone sessions and morale and welfare services. DoD-enhanced Iridium with its crosslinks and single DoD gateway is well-suited for missions which require world-wide connectivity. World-wide missions which could be undertaken by Iridium include certain VIP/Flag Travel, Logistic, CSAR, Polar, Peacekeeping/Humanitarian, and Military Support to Civilian Agencies communications. DoD-enhanced Globalstar with its CDMA technology, deployable DoD gateway and

Group Services can provide tactical mobile communications services in-theater. In-theater missions for which DoD-enhanced Globalstar is well-suited include GBS Orderwire, Logistics Support, C2 of Tactical Forces, Special Operations, and NSFS Ship-to-Shore communications. The figure below summarizes the areas that best suit these DoD-enhanced MSS.

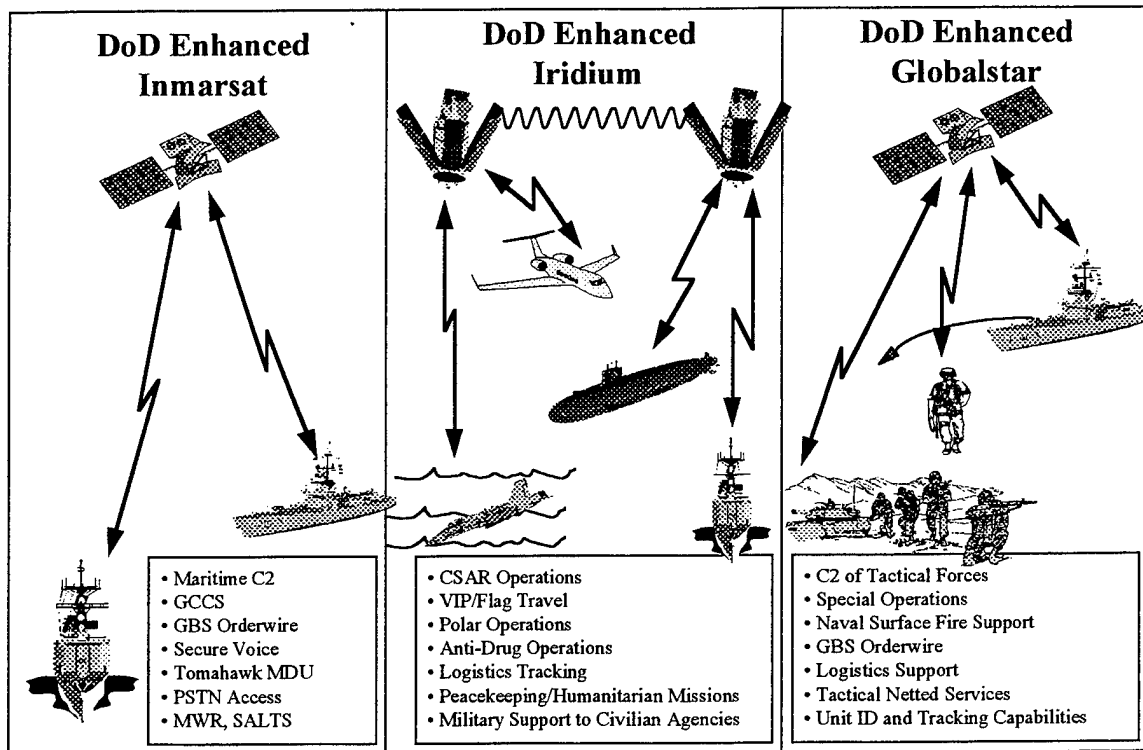

By capitalizing on each of the DoD-enhanced MSS strengths, DoD-enhanced MSS communications can provide the missing mobile communications piece in the Naval communications puzzle. In the long run, whether or not the Navy chooses to actively integrate commercial MSS into its communications infrastructure, the Navy needs to understand the implications of adversaries who will utilize commercial MSS.

ACKNOWLEDGMENT

The author would like to acknowledge the financial, academic and morale support provided to him throughout the thesis process. The financial support of Naval Space Command, Code N52, which allowed for travel to collect information vital to the development of this thesis. The academic guidance and assistance of Professor Agrawal and Professor Wadsworth in developing the final product. The morale support of my wife Nora and my daughter Kara which enabled me to complete my thesis on time.

I. INTRODUCTION

A. BACKGROUND

The Navy has made extensive use of commercial communications satellites since commercial satellite services first became available. Since the early seventies, the Navy has leased the services of commercial communications satellite systems such as Leasat to provide narrowband UHF communications capability to its widely dispersed forces worldwide. Even though numerous military communications satellites have been deployed since that time, there still exists a great gulf between the Navy's demand for narrowband satellite communications and the ability of Department of Defense (DoD) owned systems to meet that demand. Being a global force operating on all the Earth's major oceans and with information dominance becoming increasingly important, the Navy needs to expand its ability for two-way global narrowband communications. Commercial narrowband satellites can help provide that capability.

Narrowband communication is defined as low data rate communications providing voice and data communications of less than 64 kbps. Those narrowband commercial satellite communications systems operating in the UHF portion of the electromagnetic spectrum allow for the use of smaller user terminals. These smaller terminals vary from very small aperture terminals (VSAT) for geostationary (GEO) satellites and small handheld omnidirectional antennae for low earth orbiting (LEO) satellites. The narrowband commercial satellites providing these types of services are referred to as Mobile Satellite Services/Systems (MSS). The small size and portability of MSS terminals

are ideal for providing narrowband communications worldwide to the Navy who has hundreds of diverse platforms of varying size spread across the globe. The ability of two way Narrowband communications with any Navy platform anywhere in the world would greatly enhance the Navy's ability to coordinate between widely dispersed forces, pass time critical data, decrease response time to the National Command Authority's needs and increase situational awareness throughout the Navy's global forces.

Every other day it seems as if another company is entering the MSS market. Inmarsat, for one, has been providing ocean going vessels MSS for 10 to 15 years and currently, provides virtually the entire Navy with ship fixed Inmarsat terminals capable of up to 56 kbps MSS. Newly proposed MSS are focusing on the personal communication services (PCS) portion of the market that provides a mobile individual user voice and data service of up to 9.6 kbps. Iridium and Globalstar are two such satellite systems that promise to provide worldwide or virtually worldwide hand held PCS. There are other proposed MSS (summarized in Table 1-1) , however, industry and DoD analysts have found Iridium and Globalstar to be the two MSS providers which will have the largest impact on the PCS market in the near term. Inmarsat, Iridium and Globalstar are or will soon be available for Naval use and their impact on the Navy's communications architecture must be analyzed.

Parameter	Skycell	ICO	Ellipso	Odyssey
Primary Owner	AMSC (Hughes Communications)	ICO Global Communications	Mobile Communications Holdings	TRW
Orbit Type	GEO	MEO	MEO	MEO
Orbit Shape(s)	Synchronous	Circular	Circular & Elliptic	Circular
Orbit Alt (circular) km	35,786	10,400	8,068	10,355
Orbit Alt (ellipse) km	N/A	N/A	Apogee - 7,486 Perigee - 5,000	N/A
Orbit Planes (number)	1	2	3	3
Inclination(s) deg	0-1	45	1 @ 0° & 2 @ 116.6°	50
No of Sats (with spares)	2	12	17	14
Min Elev Angle (N. Lat)	10	20	25	20
Primary Coverage Lats	US & Parts S/A	70°N-55°S	70°N-47°S	70°N-55°S
Primary Coverage Longs	US & Parts S/A	All (Gaps over far northern latitudes and over ocean)	All (Gaps over far northern latitudes and over ocean)	All (Gaps over far northern latitudes and over ocean)
Unique Design	GEO Cellular	Complex antenna, onboard processing	Travels through Van Allen Belts/ New Solar Arrays	Satellite tracks earth service areas
Modulation/Handset	TDMA	TDMA	CDMA	CDMA
Antenna Beams/Satellite	23	121	37 & 61	61
Capacity, Hand-Held	6300	4500	2043	3000
Freq Band, Sat to User	1500-1600 MHz	2200 MHz	2483-2500 MHz	2483-2500
Freq Band, User to Sat	1500-1600 MHz	2000 MHz	1610-1626 MHz	1610-1626
Service Date IOC	1995	4Q 1999	3Q 1998	3Q 2000
Service Date FOC	1998	3Q 2000	2Q 1999	2Q 2001
No. Earth Stations	1	> 12	> 20	> 7
Space Segment Cost \$M	674	2600 (including earth stations)	900	3200 (including earth stations)
User Data Rates (kbps)	9.6	2.4, 4.8	0.3 - 9.6	2.4, 4.8, 9.6
Standard Handset Costs	500-700	1000	1000	500-700
Usage cost, \$ per minute	0.50	1-2	0.20-0.40	1-2

Table 1-1. Other Mobile Satellite Services Providers. After Ref. [1].

B. PURPOSE

The Navy's narrowband functional requirements are examined to identify what, if any, Naval narrowband requirements can be best satisfied using which MSS. The MSS under consideration are Inmarsat, Iridium and Globalstar. Each system is described, strengths assessed, weaknesses identified and DoD enhancements considered. An analysis of the integration of these three MSS into the Naval Communications Architecture is performed.

C. ORGANIZATION

1. Chapter II. Naval Narrowband Functional Requirements

The Navy's future narrowband functional requirements are summarized based on Naval Operations, including material drawn from the DoD SATCOM Functional Requirements Document and DoD SATCOM system limitations and the Mobile User Study Requirements Working Integrated Product Team.

2. Chapter III. Overview of Commercial Mobile Satellite Services

An overall examination of space communications is provided with three commercial MSS providers being examined in detail -- Inmarsat, Iridium and Globalstar. In addition to an overview of each system, the strengths and weaknesses of each MSS are evaluated in terms of satisfying the Navy's narrowband communications needs.

3. Chapter IV. Integration of Commercial Mobile Satellite Services into Naval Communications

Potential methods for integrating Inmarsat, Iridium and Globalstar into the Navy's communications architecture are examined. A review of potential Naval communications missions and proposed DoD enhancements to these three MSS is included.

4. Chapter V. Conclusions and Recommendations

The relative advantages and disadvantages of a Naval communications architecture based on DoD-owned MSS versus DoD-enhanced MSS are presented based on the examination of three commercial MSS. Recommendations concerning future research areas are provided.

II. NAVAL NARROWBAND FUNCTIONAL REQUIREMENTS

Naval Narrowband Functional Requirements (NNFR) have been developed by examining Naval Operations, DoD SATCOM Functional Requirements Document, examining DoD SATCOM system limitations and committee meetings such as the Mobile User Study Requirements Working Integrated Product Team. The requirements process is a cyclical process. There is no true beginning or end. What is produced after each iteration, is a snapshot in time. The MILSATCOM requirements generated is used for planning and implementation of next generation military satellite communications system which will best be able to satisfy those requirements within physical and fiscal constraints.

A. NAVAL OPERATIONS

1. Forward ...From the Sea

Forward ...From the Sea is a strategic concept adopted by the Navy and Marine Corps September 1992. ...From the Sea is a fundamental shift from the blue water, open ocean, large naval engagement strategy to a brown water, littoral regions which provides support for land based joint operations. Although the strategy has changed, the purpose of the Navy remains to project the United States' power and influence across the seas to foreign waters and shores in both peace and war. [Ref. 2: pp. 1-3]

2. Peacetime Forward Presence Operations

Naval Forces operate forward in peacetime to promote national influence, maintain access to critical areas, provide stability, deter aggression and provide an initial crisis-

response capability. Forward deployed naval forces alone are a tangible symbol of U.S. political commitments and military strength. They also promote peace through overseas engagements and partnership with U.S. allies which increases regional stability and decreases the need to fight in defense of our vital interests. Crisis response is the emergent and timely dispatch of naval forces to a specific area to render assistance or exert military force. Naval forces' forward deployment is essential to permit the United States to act quickly in meeting any crises that may affect our security. [Ref. 3: pp. 20]

3. Naval Operations -- Other than War

As part of crisis response, Naval Operations -- Other than War may require naval forces to conduct such contingency activities as show of force, freedom-of-navigation operations, short duration combat intervention operations and post-combat security restoration operations. The National Command Authority directs naval forces to protect the United States' international right to perform the following duties:

- Conduct contingency operations.
- Evacuate noncombatant personnel.
- Combat terrorism.
- Aid host nations through security assistance and foreign internal defense.
- Assist other nations in defending themselves.
- Enforce United Nations' economic sanctions.
- Participate in peace-support operations.
- Intercept vessels to prevent uncontrolled immigration.
- Plan and conduct disaster relief, humanitarian assistance, and civil support operations.
- Coordinate public health operations.
- Assist interagency counterdrug operations.

These activities maintain a visible and credible capability to fight and exercises many of the wartime capabilities which may be needed to defend our nation in time of war. [Ref. 3: pp. 21-23]

4. Sealift

Sealift is pivotal to supporting any large-scale deployment, reinforcement, and resupply. Historically, sealift has accounted for 90-95% of the total cargo delivered during military operations overseas. In order to provide this type of support, strategic sealift employs ships in three broad categories:

- Prepositioning - This capability allows the U.S. to place sustainment supplies near crisis areas for delivery to contingency forces.
- Surge - the initial deployment of U.S. based equipment and supplies in support of a contingency, transported in rapid-reinforcement shipping.
- Sustainment - Shipping that transports resupply cargoes to build up theater reserve stock levels.

Protecting logistical lines has always been a major factor in any successful campaign.

Sealift provides the U.S. with a logistical edge in any overseas operation. [Ref. 3: pp. 24]

5. Naval Operations in War

The Navy's fundamental role is sea control. Sea control protects naval forces' ability to project power ashore by controlling the entire battlespace: subsurface, surface, and airspace, both in the open ocean and littoral regions of the world. Sea control allows the U.S. to:

- Protect sea lines of communications.
- Deny the enemy commercial and military use of the seas.
- Establish an area of operations for power projection ashore and support of amphibious operations.
- Protect naval logistic support to forward deployed battle forces.

Control of the sea is accomplished through the following operations:

- Destroying or neutralizing enemy ships, submarines, aircraft, or mines.
- Disabling or disrupting enemy command and control.
- Destroying or neutralizing the land-based infrastructure that supports enemy sea control forces.
- Seizing islands, choke points, peninsulas, and coastal bases along the littorals.
- Conducting barrier operations in choke points that prevent enemy mobility under, on, and above the sea.

Control of the sea does not imply absolute control over all areas of the sea. Rather, complete sea control is only required of specific regions for particular periods of time, to allow unencumbered naval operations. [Ref. 3: pp. 26]

6. Joint Operations

Throughout the 20th century, naval forces have been operating in concert with the Army and Air Force with great success. Coherent joint doctrine has been and is continuing to be developed as a catalyst in developing ever increasing joint capabilities. Joint training, education and experience is being developed during frequent joint operations and exercises. A cornerstone to future joint operations is the development of joint C4I systems which have the following characteristics:

- Interoperable - must possess the interoperability necessary to ensure success in a joint and combined operations environment.
- Flexible - ability to meet changing situations and diversified operations with a minimum of disruption or delay.
- Responsive - system must be reliable, redundant and timely.
- Mobile - systems must be as mobile as the forces they support.
- Disciplined - ensure that limited system resources are used to the best advantage.
- Survivable - systems should be as survivable as the survival potential of the associated command centers and weapon systems.

- Sustainable - economical design and employment of C4 systems without sacrificing operational capability or survivability.

The future promises even greater integration between the services allowing the services to further complement each others' unique capabilities in time of conflict. [Ref. 4: pp. 5-9]

B. DOD SATCOM FUNCTIONAL REQUIREMENTS DOCUMENT

The Department of Defense (DoD) has a continuing need to utilize satellite communications (SATCOM) to provide for its information transfer needs in a global threat environment. The Defense Information Systems Agency (DISA) developed the DoD's SATCOM Functional Requirements Document (DSFRD) in 1996 to describe a user's needs for satellite communications service in the post-2005 time frame. The technical approach was to derive requirements from two separate databases, the Integrated Communications Data Base (ICDB) and the Emerging Requirements Data Base (ERDB) within the context of three operational scenarios: peacetime, multiple lesser regional conflict (MLRC), and combined major regional conflict (CMRC). The DSFRD intended use was for planning and study purposes.

1. Requirements Databases

The ICDB is a comprehensive data base of present day communications requirements for DoD and selected non-DoD Government agencies maintained by DISA. Contains terrestrial and commercial SATCOM data. Military SATCOM requirements are submitted by the CINCs/Agencies and are validated by the Joint Staff. The ERDB contains far-term requirements data not addressed by the ICDB. Additional factors contributing to the ERDB are force structure changes, new technologies, weapons

systems information and doctrinal changes. Emerging requirements are submitted to DISA and approved by the Joint Staff for planning and analysis purposes. The ERDB is completely compatible with the ICDB. [Ref. 5: pp. 1.2-1.3]

2. Requirements Characteristics and Functional Areas

Requirements characteristics apply in varying degrees to different classes of users and missions and across five functional areas. The requirements are unconstrained and independent of architectural solutions. The mobile and deployed warfighter's information transfer needs are the focus of the following requirements characteristics:

- **Connectivity** - The geographical coverage of the satellite communications system in reference to the users of that system and the capacity of the system relative to data throughput.
- **Protection** - The ability to avoid, prevent, negate, or mitigate the degradation, disruption, denial, unauthorized access, or exploitation of communications services by adversaries or the environment.
- **Access and control** - Access means immediate accessibility and availability when needed. Control refers to the ability to effectively plan, operate, manage and manipulate the available SATCOM resources.
- **Interoperability**- The ability of varying forces to communicate with one another quickly and effectively.
- **Flexibility** - The ability to support the full dynamic range of military operations and missions.
- **Quality of Service** - The ability to transfer information in a timely and accurate manner.

These requirements characteristics have been mapped into five functional areas to describe DoD SATCOM needs in various operational deployment scenarios. [Ref. 5: pp. 2.1-2.26]

Functional areas describe the type of SATCOM services available to the user community and the employment of SATCOM resources in supporting those services. The five functional areas are:

- **Highly Protected** - The minimum essential communications to support the National Command Authorities (NCA), CINC conferencing, Intergrated Tactical Warning and Attack Assessment (ITW/AA), and SIOP force element missions. The key attribute is survivability in a nuclear stressed environment.
- **Protected** - The services supporting tactical forces. Minimizing interference, interception or geolocation of SATCOM signals. The key attribute is survivability on a conventional battle field.
- **Narrowband Services (Netted)** - A single low capacity (<64 kbps) netted radio circuit operating in half-duplex (sometimes even simplex) mode. The types of connectivity within this functional area are: netted/conference, report back, broadcast and paging.
- **Narrowband Services (Point-to-Point)** - The requirement of two users or groups of users to communicate with each other. Typically consisting of a single <64 kbps full duplex SATCOM circuit linking two user terminals. Range of missions include support, training, joint operations and combined operations.
- **Wideband Services** - Full duplex (point to point) and simplex modes (broadcast) at rates greater than 64 kbps.

The threats which may be present in an operational environment are summarized in Table

2-1. Requirements characteristics can vary among functional areas depending upon the class of users and type of missions encountered. [Ref. 5: pp. 2.27-2.30]

Operational Threat	Mitigation Technique
High Altitude Electromagnetic Pulse (HEMP) A sudden very large surge of current produced by a nuclear detonation at high altitude.	HEMP The hardening and shielding of electronics to mitigate EMP effects.
Scintillation The collection of effects on the propagation medium caused by nuclear detonations.	Anti-Scintillation (AS) Techniques used to minimize effects of scintillation
SIGINT The intercept and the collection signals intelligence.	Low Probability of Intercept (LPI) The protection from intercept and the collection signals intelligence.
Detecting and Direction Finding Detecting a signal and following its direction back to its source.	Low Probability of Detection (LPD) The ability to transmit a communications signal while denying its detection and source location to maintain covertness of operations.
Jamming The deliberate interference with electromagnetic energy for the purpose of preventing or reducing someone else's use of the electromagnetic spectrum.	Anti-Jam (AJ) Using methods and techniques to decrease the likelihood of communications disruption due to jamming.

Table 2-1. Operational Threats and Mitigation Techniques. From Ref. [5].

3. Operational Deployment Scenarios

DoD SATCOM requirements were presented in the context of three operational scenarios: Peacetime, CMRC, and MLRC. These scenarios provided the framework used to evaluate future DoD SATCOM system capabilities in an operational setting. Because it was impossible to predict where future conflicts would occur, the scenarios are independent of geographic regions and the size of the theater of operations vary from

250,000 square miles for the smallest MLRC scenario and to 5,000,000 for the largest CMRC scenario. [Ref. 5: pp. 3.1]

a. Peacetime Scenario

Normal day-to-day operations fall into this category. U.S. Forces are not engaged in any crisis operations or conflict. The majority of these requirements represent the background SATCOM requirements necessary in the more stressful warfighting environments. Strategic forces deployed worldwide, VIP travel, forward deployed forces, afloat forces performing global operations, joint operations, combined operations and training all fall into the Peacetime Scenarios category. [Ref. 5: pp. 3.1-3.2]

b. Combined Major Regional Conflict Scenario (CMRC)

The CMRC Scenario represents the use of a large force in two geographically separate regions. In this worst-case scenario, the U.S. and her allies are engaged in near-simultaneous major regional conflicts (MRCs). Table 2-2 shows the distribution of forces for each Areas of Responsibility (AOR) used for the CMRC Scenario. Concentration of significant forces in two limited geographical areas could potentially place a severe strain on the ability of the DoD SATCOM systems to adequately satisfy DoD needs in a CMRC environment. This problem would be exacerbated if forces in each AOR are competing for satellite resources within the same satellite region. [Ref. 5: pp. 31-3.4]

Forces Region	Carrier Battle Group	Amphibious Ready Group	Army Corps	Army Division	Marine Expeditionary Force	Fighter Wing Equivalent
Theater 1	5	2	2	7	1+	7
Theater 2	4	1	1	3	1	9
Total	9	3	3	10	2+	16

Table 2-2. CMRC Force Structure. From Ref. [5].

c. Multiple Lesser Regional Conflict Scenario (MLRC)

MLRC involves use of medium size forces into a localized area in support of U.S. interests. The MLRC scenario analyzes DoD SATCOM architecture options in accommodating the needs of dispersed users in a combat environment. To develop this scenario, forces were dispersed to four regions to support various operations including peacekeeping, humanitarian and conflict missions. Two of the regions utilize sizable forces under operational command of a CINC and two regions use smaller forces under the command of a Commander, Joint Task Force. Table 2-3 shows the apportionment of MLRC forces and Table 2-4 Compares CMRS and MLRC force structures. [Ref. 5: pp. 3.4 - 3.5]

Forces Region	Carrier Battle Group	Amphibious Ready Group	Army Corps	Army Division	Marine Expeditionary Force	Fighter Wing Equivalent
Theater 1	2*	1	1	2	1	4
Theater 2	2*	1	3	1		4
Theater 3	2*	1		1		2
Theater 4	1	1		1	0.5	1
Total	7	3	2	7	2+	11

* One CVGB in the AOR with the second in transit.

Table 2-3. MLRC Force Structure. From Ref. [5].

Unit \ Scenario	CMRC	MLRC
Army Corps	3	2
Army Division	10	7
Carrier Battle Group	9	7
Amphibious Ready Group	3	3
Marine Expeditionary Force	2+	2+
Fighter Wing equivalent	16	11

Table 2-4. CMRC/MLRC Force Structure Comparison. From Ref. [5].

4. Capacity Estimates

Using data from the requirements databases and the operational scenarios described above, an analysis was made and tables created to reflect each operational scenarios' capacity by composite, highly protected, protected, minimally protected and by terminal categories.

a. Composite Capacity

Table 2-5 presents the minimum estimated narrowband SATCOM throughput requirements in the 2005-1010 time frame for each of the three scenarios discussed earlier. [Ref. 6: pp. 4.9 - 4.10]

Scenario \ Circuit Type	Peacetime		CMRC		MLRC	
	Mbps	Circuits	Mbps	Circuits	Mbps	Circuits
Narrowband (Netted)	2.5	900	6.5	1500	7.0	1500
Narrowband (Point to Point)	115	2550	125	3200	135	3600
Total Narrowband	117.5	3450	131.5	4700	142	5100

Note: For netted service, "circuits" column equals number of "networks"

Table 2-5. Narrowband Composite Capacity (2005-2010). After Ref. [6].

b. Highly Protected Capacity

The United States nuclear forces, ITW/AA and the NCA all require global high level of protection capable of operating in a nuclear trans- and post-attack environment. Table 2-6a describes the highly protected narrowband capacity requirements and Table 2-6b breaks those requirements into requisite protection mitigation measures.

[Ref. 6: pp. 4.11 - 4.12]

Scenario Circuit Type	Peacetime		CMRC		MLRC	
	Mbps	Circuits	Mbps	Circuits	Mbps	Circuits
Narrowband (Netted)	0.4	165	2.0	210	2.0	210
Narrowband (Point to Point)	1.6	115	1.6	130	1.6	130
Total Narrowband	2	280	3.6	340	3.6	340

Note: For netted service, “circuits” column equals number of “networks”.

Table 2-6a. Narrowband Highly Protected Capacity (2005-2010). After Ref. [6].

Scenario Mitigation Technique	Peacetime		CMRC		MLRC	
	Mbps	Circuits	Mbps	Circuits	Mbps	Circuits
Anti-Jam	20	300	20	350	20	350
Anti-scintillation	22	300	22	350	22	350
HEMP	16	250	16	280	16	280
LPI	4.5	40	5	50	4.0	35
LPD	5	40	5	50	4.0	35

Note: Includes wideband and most circuits require a combination of these features.

Table 2-6b. Highly Protected Capacity Break-out (2005-2010). After Ref. [6].

c. Protected Capacity

The United States needs a robust anti-jam, LPI, and LPD protection for many in-theater tactical forces to include maritime and amphibious battle group. These forces operate in close proximity to hostile forces and must be able to protect their most critical SATCOM links. Table 2-7a provides the narrowband protected capacity and Table 2-7b breaks the protected capacity into its constituent parts. [Ref. 6: pp. 4.12 - 4.13]

Scenario / Circuit Type	Peacetime		CMRC		MLRC	
	Mbps	Circuits	Mbps	Circuits	Mbps	Circuits
Narrowband (Netted)	1.0	440	3.0	780	3.0	800
Narrowband (Point to Point)	12	420	13	480	24	700
Total Narrowband	13	860	16	1260	27	1500

Note: For netted service, "circuits" column equals number of "networks".

Table 2-7a. Narrowband Protected Capacity (2005-2010). After Ref. [6].

Scenario / Mitigation Technique	Peacetime		CMRC		MLRC	
	Mbps	Circuits	Mbps	Circuits	Mbps	Circuits
Anti-Jam	600	1300	1346	2150	1600	2500
LPI	25	330	300	700	250	750
LPD	40	330	300	700	250	750

Note: Includes wideband and most circuits requiring LPI/LPD also require AJ.

Table 2-7b. Protected Capacity Break-out (2005-2010). After Ref. [6].

d. Minimally Protected Capacity

The minimal protected group of SATCOM are those communications that do not require any AJ/LPI/LPD capabilities. This category satisfies a subset of the users whose requirements who are separately covered in highly survivable and protected service categories who may also desire to operate in a non-protected mode until the mission or threat dictate otherwise. Logistics and administrative coordination communications are examples of minimally protected communications. Table 2-8 depicts minimally protected capacity estimates. [Ref. 6: pp. 4.13 - 4.14]

Scenario Circuit Type	Peacetime		CMRC		MLRC	
	Mbps	Circuits	Mbps	Circuits	Mbps	Circuits
Narrowband (Netted)	1	300	1.5	500	2.0	500
Narrowband (Point to Point)	100	2000	110	2600	110	2750
Total Narrowband	101	2300	111.5	3100	112	3250

Note: For netted service, "circuits" column equals number of "networks".

Table 2-8. Narrowband Minimally Protected Capacity (2005-2010). After Ref. [6].

e. Terminal Capacity

DoD SATCOM terminal capacity requirements for the three operational scenarios are depicted in Table 2-9a for Narrowband (netted) and Table 2-9b for Narrowband (point to point). Both tables summarize the capacity between the following categories of terminals: fixed to fixed (F/F); fixed to mobile (F/M); fixed to transportable (F/T); mobile to mobile (M/M); transportable to mobile (T/M); and transportable to transportable (T/T). [Ref. 5: pp. 4.6 - 4.8]

Scenario Terminal Type	Peacetime		CMRC		MLRC	
	Mbps	Circuits	Mbps	Circuits	Mbps	Circuits
Fixed/Fixed	.12	17	.15	27	.12	18
Fixed/Mobile	.08	61	.1	72	.07	67
Fixed/Transportable	.25	28	.3	43	.38	51
Mobile/Mobile	.18	128	.28	233	.27	251
Transportable/Mobile	.05	7	.04	10	.1	12
Transportable/ Transportable	.39	42	.6	105	.62	109

Note: For netted service, "circuits" column equals number of "networks".

Table 2-9a. Narrowband (Netted) Capacity by Terminal (2005-2010). After Ref. [5].

Scenario Terminal Type	Peacetime		CMRC		MLRC	
	Mbps	Circuits	Mbps	Circuits	Mbps	Circuits
Fixed/Fixed	85	1769	.84	1912	.83	1885
Fixed/Mobile	1	204	2	309	4	551
Fixed/Transportable	2	43	7	238	5	235
Mobile/Mobile	.04	2	0	0	0	0
Transportable/Mobile	0	0	.8	30	.9	35
Transportable/ Transportable	.04	4	10	102	6	73

Table 2-9b. Narrowband (Point to Point) Capacity by Terminal (2005-2010). After Ref. [5].

C. DOD SATCOM SYSTEM LIMITATIONS

The current and near term planned for DoD-owned SATCOM systems were designed to satisfy military requirements and weapon systems envisioned ten to twenty years ago. With the explosion in information technology and the vast increase in the information needed to support modern military operations, the current systems are not able to provide the connectivity, protection, flexibility or the interoperability needed to

support today's requirements let alone support tomorrow's even greater needs. In staying within the scope of this thesis, discussion of capabilities or lack thereof will be confined to narrowband mobile UHF communications. The capabilities which will be discussed are replenishment of DoD SATCOM systems, connectivity, protection, access and control, interoperability, flexibility and quality of service.

1. Replenishment of DoD-Owned Capability

DoD SATCOM systems even with planned upgrades will be unable to support the CMRC scenario in the 2003-2008 time frame, when they are finally scheduled for replacement. The legacy systems of that time are expected to meet less than 25 percent of DoD's forecasted need. Figure 2-1 depicts DoD SATCOM systems' anticipated life expectancies. [Ref. 6: pp. 3.1 - 3.2]

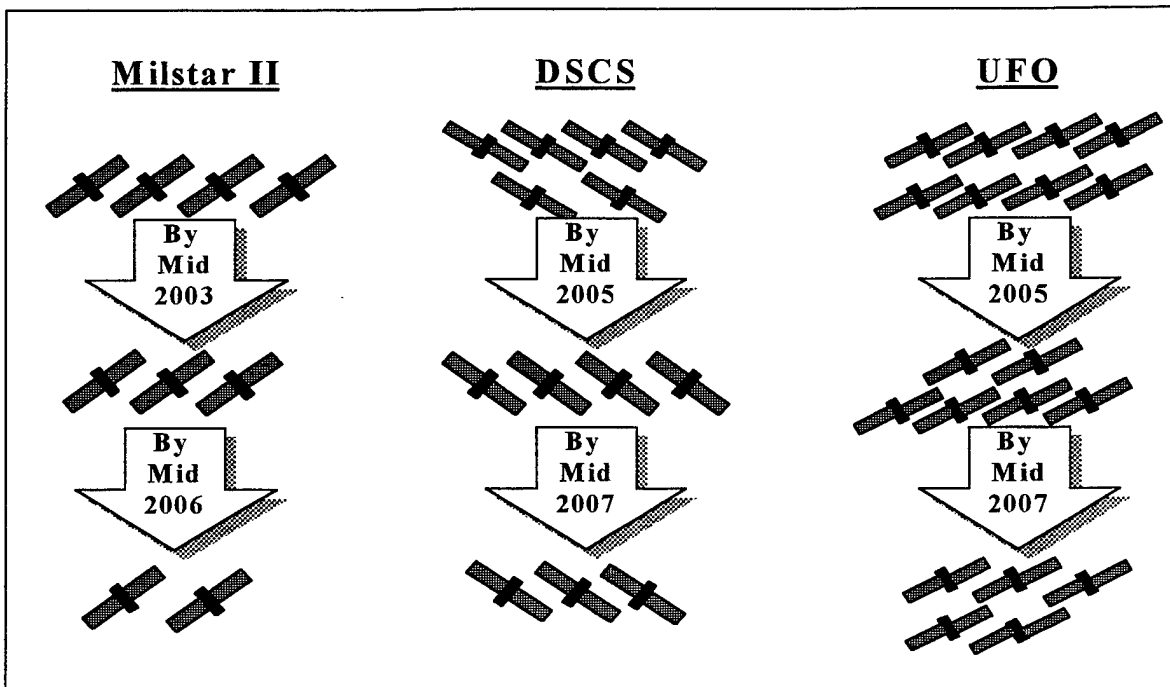

Figure 2-1. Current MILSATCOM Life Expectancy. After Ref. [6].

2. Connectivity

Connectivity, as discussed previously, includes both coverage and capacity. All of DoD-owned systems are geosynchronous satellites which limits their coverage to everywhere between 65° North and 65° South latitudes. Effectively no polar coverage is available. And in some areas, the capacity available is insufficient to meet U.S. needs and maintain continuous connectivity to all forces. Concerning capacity, current DoD SATCOM systems lack the capability to meet rapidly growing capacity requirements of tomorrow's information hungry, dynamic, flexible and mobile forces. Of particular interest, these systems cannot now and will not in the near future be able to provide the required information throughput to small SATCOM terminals/antennas required for on-the-move or at-the-pause communications required for battlefield information dominance. DoD owned systems that can be used for mobile narrowband UHF communications are MILSTAR and UFO. Table 2-10 compares the total number of UHF circuits these systems can support at full strength with the Peacetime Scenario Narrowband mobile circuit requirements provided in Tables 2-9a and 2-9b. The results of this exercise shows that DoD mobile UHF satellite capability falls well short of meeting user demands of even the least stressful scenario. DoD SATCOM shortfall in the UHF area becomes more pronounced if operations are concentrated in one part of the world. [Ref. 6: pp. 3.2 - 3.4]

	Calculations	Totals
UHF MILSATCOM	MILSTAR (4 sat * 4 Circuits/sat) + UFO (8 sat * 21 Circuits) =	184
Narrowband Mobile (Netted and Point to Point)	F/M(61+206) + M/M(128 + 2) + T/M (7 + 0) =	397
Unfulfilled Requirements	Capabilities (184) - Requirements (397) =	213

Table 2-10. DoD SATCOM UHF Unfulfilled Requirements.

3. Protection

DoD current generation of SATCOM does not adequately protect its communications circuits from disruption or exploitation. The UHF signals used for mobile narrowband on the move communications is extremely susceptible to jamming, detection and interception. Satellite terminal and control segments are also not well protected against all probable threats both physical and electronic, especially those segments that are located abroad. [Ref. 6: pp. 3.4 - 3.5]

4. Access and Control

DoD SATCOM system has significant force structure dedicated to managing and control. Shortcomings do exist, however, new management techniques are being employed to ensure that the time needed to identify, validate and support new or changed requirements is greatly reduced. A system is in place to ensure access to SATCOM resources on a priority basis. DoD control allows for dynamic allocation of resources to meet changing needs. [Ref. 6: pp. 3.5 - 3.6]

5. Interoperability

Interoperability was not considered when DoD SATCOM systems were initially developed. Developed and optimized for specific user communities needs, DoD SATCOM has only limited joint/combined communications interoperability. Many DoD SATCOM systems use different frequency bands, waveforms, protocols, control concepts and terminals. With no inter-system interoperability, operational flexibility is limited among users of the different systems and even the same SATCOM system because the network resources are parceled out in fixed allocations. Finally, DoD SATCOM systems have little if any interoperability and access to terrestrial systems as they have not yet been fully integrated into the Defense Information Infrastructure (DII). [Ref. 6: pp. 3.6 - 3.7]

6. Flexibility

Flexibility is defined as the use of SATCOM while U.S. forces are engaged in mobile, dynamic operations across the full spectrum of conflict. Communication on-the-move with current DoD SATCOM systems is exceedingly difficult. Today's DoD SATCOM systems are not always optimized for the user and platform. With the diverse types of terminals needed for use of diverse frequency bands, a warfighter would be required to transport multiple terminals into the combat or install them on the same platform. The current mobile terminal infrastructure is not "user friendly". Most of the current terminals were designed to be operated by dedicated, specially trained personnel. Finally, warfighters will out run their communications as the throughputs to ships, aircraft

and portable terminals will quickly overtax the current satellite constellations. [Ref. 6: pp. 3.7]

7. Quality of Service

Current systems will not meet future requirements for voice recognition and intelligibility. DoD SATCOM systems are already beyond totally committed. Any additional users will only exacerbate communications delays and blockages. Quality problems, system delays and blockages greatly diminishes situational awareness and dominant battlespace knowledge. Lack of communication will, in effect, greatly reduce combat efficiency and threaten mission success. [Ref. 6: pp. 3.7 - 3.8]

D. MOBILE USER STUDY REQUIREMENTS (MUS) WORKING INTEGRATED PRODUCT TEAM (WIPT)

1. MUS WIPT Overview

Naval Space Command facilitated the first MUS WIPT meeting 18 March 1997 with continuing MUS meetings being scheduled periodically throughout 1997. The MUS WIPT was tasked by the Deputy Under Secretary of Defense for Space (DUSDS), to develop and prioritize mobile user requirements sets for a follow-on UFO architecture to be implemented around 2005 - 2015 timeframe and to discuss commercial and military options. Once completed, the MUS WIPT will forward requirements sets and recommendations to an engineering committee which will explore architectural options which will address those recommendations. The WIPT team is composed of numerous experts in the field of requirements, military SATCOM and commercial SATCOM. Of those experts, six members are considered voting members. Those voting members,

representing the Navy, Air Force, Army, Marine Corps, DISA and Joint Chiefs Staff, vote on any items of contention throughout the meeting. The 16-17 April 1997 meeting led to a prioritized list of requirements and how commercial MSS stacks up against those requirements. [Ref. 7]

2. MUS WIPT Requirements

From the numerous requirements discussed, the following eight MUS WIPT requirements were agreed upon during the April meeting:

- **Assured Access** - The assurance that SATCOM access will be available when needed.
- **Netted Comms** - Communications, normally half duplex, which allows all users to receive from and send to all other users. Critical to C2.
- **Comms On-The-Move** - Communications to highly mobile and/or disadvantaged users that requires a small terminal to include hand held terminals and small platform terminals (ships, boats, trucks and aircraft).
- **Joint Interoperable** - The ability to exchange information services satisfactorily between joint forces in a timely and efficient manner.
- **World Wide Coverage** - Communications coverage between approximately 65° North and 65° South Latitudes.
- **Point to Point Comms** - Communications link from one specific node to another specific node. Can be duplex or simplex.
- **Broadcast** - Simplex communications. One way transmission from a single uplink source to an earth coverage downlink listening area. "A one to many topology".
- **Polar Coverage** - Coverage that extends to the extreme northern and southern polar regions (above 65° N and below 65° S).

Table 2-11 records the voting members rankings of the requirements listed above. [Ref. 7]

Required Capabilities	Voting Members							
	USA	USN	USAF	USMC	JCS	DISA	AVG	RANK
Assured Access	1	1	1	2	1	1	1.17	1
Netted Comms	2	2	2	1	2	2	1.83	2
Comms On The Move	3	3	6	3	3	4	3.67	3
Joint Interoperable	4	4	7	5	4	6	5.00	4
World Wide coverage	5	5	5	7	6	3	5.17	5
Point to Point Comms	6	8	4	6	7	8	6.50	6
Broadcast	6	8	4	6	7	8	6.50	7
Polar	7	7	8	8	8	7	7.50	8

Table 2-11. Required Capabilities Voting Results. From Ref. [7].

3. MSS Satisfying MUS WIPT Requirements

Upon agreement on the eight most important requirements, multiple briefings on current and future commercial mobile satellites were delivered to the MUS WIPT. After lengthy discussion among the entire group, the various MSS under consideration were rated on a red, yellow and green scale against the eight MUS WIPT requirements. Red is for total nonsatisfaction, yellow for partial satisfaction and green for total satisfaction. Table 2-12 lists the MSS which have been discussed previously in chapter one or will be discussed in chapter three, and their rating versus the eight requirements. [Ref. 7]

Required Capabilities	Mobile Satellite Services						
	Inmarsat	Skycell	Globalstar	Iridium	ICO	Ellipso	Odyssey
Assured Access	Red	Red	Ylw	Red	Red	Red	Red
Netted Comms	Red	Red	Ylw	Red	Red	Red	Red
Comms On The Move	Ylw	Ylw	Grn	Grn	Grn	Grn	Grn
Joint Interoperable	Ylw	Ylw	Ylw	Ylw	Ylw	Ylw	Ylw
World Wide coverage	Grn	Red	Ylw	Grn	Ylw	Ylw	Ylw
Point to Point Comms	Grn	Grn	Grn	Grn	Grn	Grn	Grn
Broadcast	Grn	Ylw	Ylw	Ylw	Red	Red	Red
Polar	Red	Red	Red	Grn	Ylw	Red	Ylw

Table 2-12. MSS Ability to Satisfy Required Capabilities. From Ref. [7].

E. SELECTION OF MSS FOR FURTHER STUDY

By examining Naval Doctrine, DoD FRD, DoD SATCOM shortcomings and MUS WIPT's grading of MSS, the author has identified three systems for potential integration into Naval Communications. Those three systems are Inmarsat, Iridium and Globalstar. The primary reasons that Skycell, Ellipso, ICO and Odyssey were not selected for further study is that none of them currently provide for a capability of world wide communications coverage between 70° N and 70° S latitudes and the desire to keep the scope of this thesis within manageable bounds. Skycell only intends on providing coverage for North and South America. The three MEO systems do not choose to provide coverage over open ocean and polar areas. Instead, they have operational policies which require them to concentrate the beams of their satellites on the land masses at the expense of nonpopulated areas, such as the ocean and polar regions. If these three systems change these policies, DoD's use of their services should be reconsidered. Table 2-13 provides further clarification why these systems were excluded. The three systems selected will be discussed in detail in subsequent sections to include their strengths, weaknesses, possible enhancements and potential integration into Naval communications.

MSS	Reasons for Exclusion
Skycell	<ul style="list-style-type: none"> • Fails to satisfy four out of eight MUS requirements. • Fully meets only the Comms on the Move requirement. • Most notable failure - World Wide Coverage. Initial plan is to concentrate only on North and South America. • Navy requires open ocean coverage.
ICO	<ul style="list-style-type: none"> • Fails to satisfy three out of eight MUS requirements. • Fully meets only Comms on the Move requirement and Point to Point Comms. • Most notable failure - listed as yellow for World Wide coverage, however, has no current plan to provide open ocean or polar coverage. • Navy requires open ocean coverage
Ellipso	<ul style="list-style-type: none"> • Fails to satisfy four out of eight MUS requirements. • Fully meets only Comms on the Move requirement and Point to Point Comms. • Most notable failure - listed as yellow for World Wide coverage, however, has no current plan to provide open ocean or polar coverage. • Navy requires open ocean coverage.
Odyssey	<ul style="list-style-type: none"> • Fails to satisfy three out of eight MUS requirements. • Fully meets only Comms on the Move requirement and Point to Point Comms. • Most notable failure - listed as yellow for World Wide coverage, however, has no current plan to provide open ocean or polar coverage. • Navy requires open ocean coverage.

Table 2-13. Reasons for MSS Exclusion. From Ref. [7].

F. DOD UHF SYSTEMS VS MSS

DoD UHF Systems (Milstar and UFO) as discussed before cannot meet the demand for their services. Secondly, being UHF systems they inherit that frequency bands limitations, specifically, its vulnerabilities to jamming, detection and exploitation. These systems also require more powerful specialized transceivers requiring dish antennae or other directional antennae limiting its mobility. Finally, using the MSS WIPT required capabilities, DoD UHF systems do not fully meet all of the MSS WIPT requirements with

the assured access being a yellow because DoD does control the satellites, but the satellites UHF capacities are severely limited. Table 2-14 compares DoD UHF Systems versus MSS systems overall against the MSS WIPT required capabilities. The results indicate that though MSS is no panacea, DoD UHF Systems cannot fully meet all of the MUS WIPT requirements either. Most notably, true communications on the move is a problem area and DoD UHF Systems totally fail to meet Joint Interoperable and Polar requirements.

Required Capabilities	DoD UHF Systems	MSS Totals
Assured Access	Yellow	Yellow
Netted Comms	Green	Yellow
Comms On The Move	Yellow	Green
Joint Interoperable	Red	Yellow
World Wide coverage	Green	Green
Point to Point Comms	Green	Green
Broadcast	Green	Yellow
Polar	Red	Green

Table 2-14. Using MSS WIPT Requirements to compare DoD UHF Systems & MSS.

III. OVERVIEW OF COMMERCIAL MOBILE SATELLITE SERVICES

A. SPACE COMMUNICATIONS

1. Space Segment

The space segment of a satellite system is composed of a satellite's subsystems, orbit and the frequency bands in which it operates. A satellite consists of seven main subsystems which affect the overall performance and design life of a satellite. As with all complex systems, performance and design issues must be addressed by making necessary trades between the various subsystems. The subsystems from which trades must be made are described in Table 3-1. [Ref. 8: pp. 2-2]

Subsystem	Function
Antenna	Enables Transmission and Reception of Radio Signals
Transponder	Converts Uplink Signal to Downlink Signal
Attitude	Maintains Acceptable Orientation of Satellite
Propulsion	Maintains Satellite within Acceptable Orbital Tolerances, Assists in Maintaining Attitude
Electrical Power	Generates, Stores, and Distributes Electricity Throughout the Satellite
Telemetry, Tracking, and Control (TT&C)	Enables Ground Control of Subsystems, Monitoring of Subsystems, and Satellite Tracking
Thermal Control	Maintains Requisite Operating Temperatures of Subsystems

Table 3-1. Satellite Subsystems. From Ref. [8]

A satellite's orbital regime directly affects coverage area, size of each satellite, cost of each satellite, the number of satellites necessary to provide similar services and the size of the antenna necessary to receive equivalent signals. Geostationary orbits (GEO) are

located in the equatorial plane of the earth, at an altitude of approximately 36000 kilometers or 22000 miles and thus have a period approximately equal to the earth's rotation rate. This enables a single GEO satellite to have continuous coverage over a fixed area of the earth's surface (Figure 3-1), with only three GEO satellites being required to cover the entire earth's surface between approximately 70° N to 70° S latitudes. The large distance which has to be traversed by the signal from GEO to a receiver on earth and back requires large antennas either in space, on the ground or both.

[Ref. 8: pp. 2-2, 2-3]

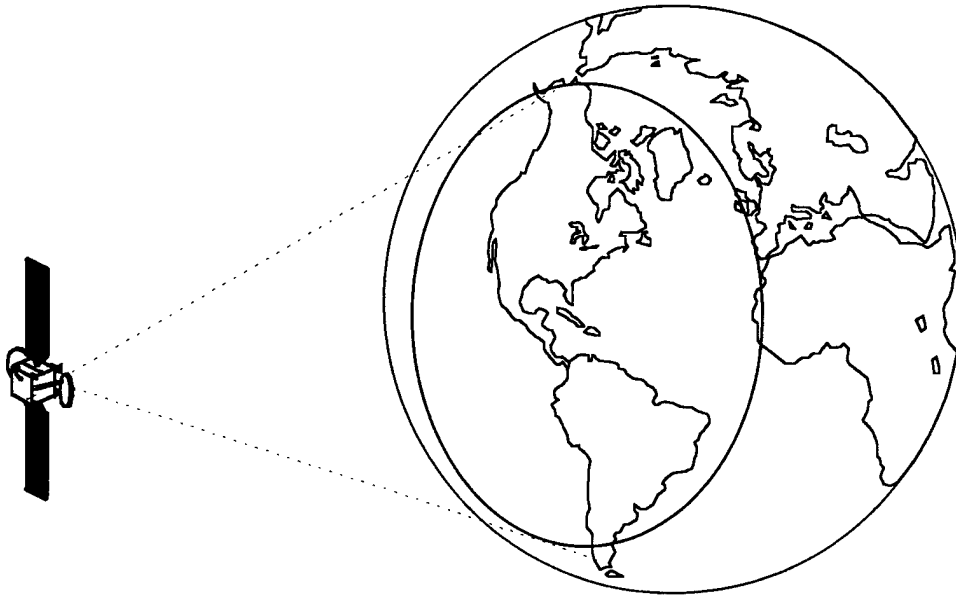

Figure 3-1. Typical GEO Satellite Coverage Area. From Ref. [8]

Low earth orbit (LEO) satellites, in contrast to the GEO satellites, are those satellites located at altitudes ranging from 400 km to 1400 km with periods of 100's of minutes. With comparatively small coverage areas that move rapidly across the earth's

surface, LEOs require a greater number of satellites to obtain the same coverage as a GEO satellite (Figure 3-2). However, given the correct number of satellites with the appropriate inclination, a LEO system can provide continuous worldwide coverage even at the poles.

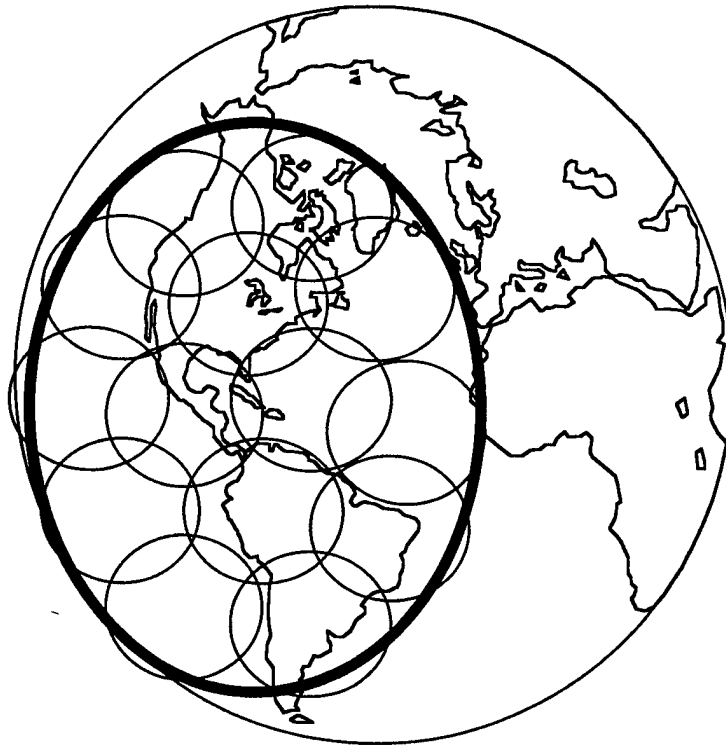

Figure 3-2. Numerous LEO Coverage Areas within GEO Footprint.

LEO satellite signals suffer a much lower free space loss (FSL) than GEO signals. In satellite communications, FSL represents the communications link loss in free space (vacuum). The lower FSL experienced by LEO satellites enables LEO terminals to be much more compact when compared to GEO terminals. Finally, there is a signal delay which increases with a satellite's distance from earth. This delay is approximately 0.018 seconds for round trip communications via a LEO satellite and about 0.5 second delay for

round trip communications via a GEO satellite. The FSL for various satellite frequencies at typical GEO and LEO altitudes are presented in Table 3-2. [Ref. 8: pp. 2-10, 2-11]

Band Name	Frequency	Free Space Loss	
		GEO Satellites (35,800 km)	LEO Satellites (750 km)
L	1.5 GHz	187.0 dB	153.5 dB
S	3.0 GHz	193.1 dB	159.5 dB
C	6.0 GHz	199.1 dB	165.5 dB
X	10.0 GHz	203.5 dB	169.9 dB
Ku	15.0 GHz	207.0 dB	173.5 dB
K	25.0 GHz	211.5 dB	177.9 dB

Table 3-2. Free Space Loss for a GEO and LEO Satellite. After Ref. [8].

The satellite frequency bands listed in Table 3-2 are set by the International Telecommunications Union (ITU). Each frequency band is associated with particular type of services authorized by the ITU (Table 3-3). Among these services are fixed satellite services (FSS) which refer to large fixed antenna terminals, mobile satellite services (MSS) referring to low data rate mobile terminals and broadcast satellite services which are high data rate one-way broadcasts to very small aperture terminals. For the three systems analyzed in this thesis, L-Band and S Band will be utilized. The advantages of these bands are the small to moderate antenna size required and the negligible atmospheric effects. Disadvantages include moderate-to-low data capacity and susceptibility to jamming. [Ref. 9: pp. 5-26]

Band Designation	Frequency Range	Services
L - Band	1 GHz - 2 GHz	FSS, MSS, BSS and Microwave Communications
S - Band	2 GHz - 4 GHz	FSS, MSS
C - Band	4 GHz - 8 GHz	FSS, MSS - terrestrial radio relay microwave systems
X - Band	8 GHz - 12 GHz	FSS, MSS - terrestrial mobile services. Government and Military services especially US and Russia
Ku - Band	12 GHz - 18 GHz	FSS, MSS, BSS
K - Band	18 GHz - 27 GHz	FSS

Table 3-3. Radio Frequency Bands Used for Satellite Communications. After Ref. [9].

2. Ground Segment

The ground segment is a complex system which is comprised of three categories of earth terminals -- fixed, mobile and earth terminal centers. Feederlink, hub, gateway, base and remote antennas are examples of fixed terminals. Included in the mobile terminals category are vehicle mounted, portable, handheld, messaging, remote data and paging. Earth terminal center supports various functions of the satellite system. Typical earth terminal processing centers are Network Control Center, TT&C Center and the Data Communications Center. Table 3-4 summarizes the different terminal and system center types, their functions, and their characteristics.

Ground Segment Types	Function	Characteristics
Fixed Terminals		
Feederlink Station	Supports all User Links, Providing High Capacity Communications Link.	Large Tracking Antenna(s), Can Support Remote Antennas
Hub Station	Supports Indirect Terminal Connections Using Star Configuration	Large Tracking Antenna(s), Supports Small Terminal Connections
Gateway Station	Connects Satellite To the PSTN	Switches Satellite Links To PSTN Trunks and Converts Satellite Network Protocols To PSTN
Gateway Station	Connects Private Network to Satellite	Large Tracking Antenna
Remote Antenna-RF Units	Support Only Antenna and RF Units with Connections to Remaining earth Station Subsystems	Large Tracking Antennas Located at Distances 10-30 km from Other sites
Mobile Terminals		
Vehicle Mounted Terminal	Voice, Data, Facsimile	Permanently Connected to Vehicle and Runs on Vehicle Battery
Portable Terminal	Voice, Data, Facsimile	Runs on Internal Batteries or Can Be Connected to Vehicle or to an AC Outlet, Brief Case Size
Handheld Voice Terminal	Voice Input/Reception, Provides Connection for Other Devices	Possible Dual Mode, i.e., Satellite or Cellular
Messaging Terminal	Message, Data Entry, Message Display	Keyboard Input
Remote Data Terminal	Monitor, Track, Alert, Control	Passive Communicators
Paging Terminal	Paging	Passive Communicators
Earth Processing Terminals		
Network Control Center	Allocates and Controls All Network Functions	Connected to All Feederlink or Hub Earth Stations
TT&C Center	Collect Telemetry, Process Tracking Data, Control the Satellite	At Least One is Required Per System
Data Communications Centers	Process and Distribute User Data Relayed by Satellite	Interface Point for User Connections to the PSTN or other Communications Systems

Table 3-4. Ground Segment Terminals. After Ref. [9].

3. Multiple Access Methods

With numerous ground segment terminals requiring access to the same bandwidth of a single transponder on a satellite, a multiple access scheme must be employed to utilize the satellite's resources efficiently. Of the multiple access schemes available, three will be

considered -- Frequency Division Multiple Access (FDMA), Time Division Multiple Access (TDMA) and Code Division Multiple Access. Table 3-5 briefly describes advantages and disadvantages of FDMA, TDMA and CDMA which will be discussed in more detail in the following subsections. [Ref. 8: pp. 2-18]

Access Methods	Advantages	Disadvantages
CDMA	Allows ranging, multipath mitigation, random access, soft hand-off, LPI/LPD, jam resistant, high frequency reuse	Complex, hardware, needs accurate power controls, high data rates are difficult
FDMA	Simple hardware, no synchronization needed between channels	Multiple carriers can cause intermodulation distortion, reallocations difficult, low reuse, hard hand-offs, fading sensitive
TDMA	Efficient use of power	All channels must be synchronized, complex hardware, low reuse, hard hand-offs, fading sensitive

Table 3-5. Access Method Advantages and Disadvantages. From Ref. [8].

a. Frequency Division Multiple Access (FDMA)

FDMA is characterized by frequency separation of signals. A satellite's transponder's available bandwidth is divided into frequency band segments where each segment is assigned to a user. Each earth station is assigned a specific uplink and downlink frequency. The number of segments can vary from one, where an entire transponder is assigned to a single user, to literally hundreds of segments. To avoid cochannel interference and intermodulation problems between multiple users, a network manager has to "balance" the power and ensure proper spacing between carriers. Figure 3-3 demonstrates the concept of FDMA. [Ref. 10: pp. 394]

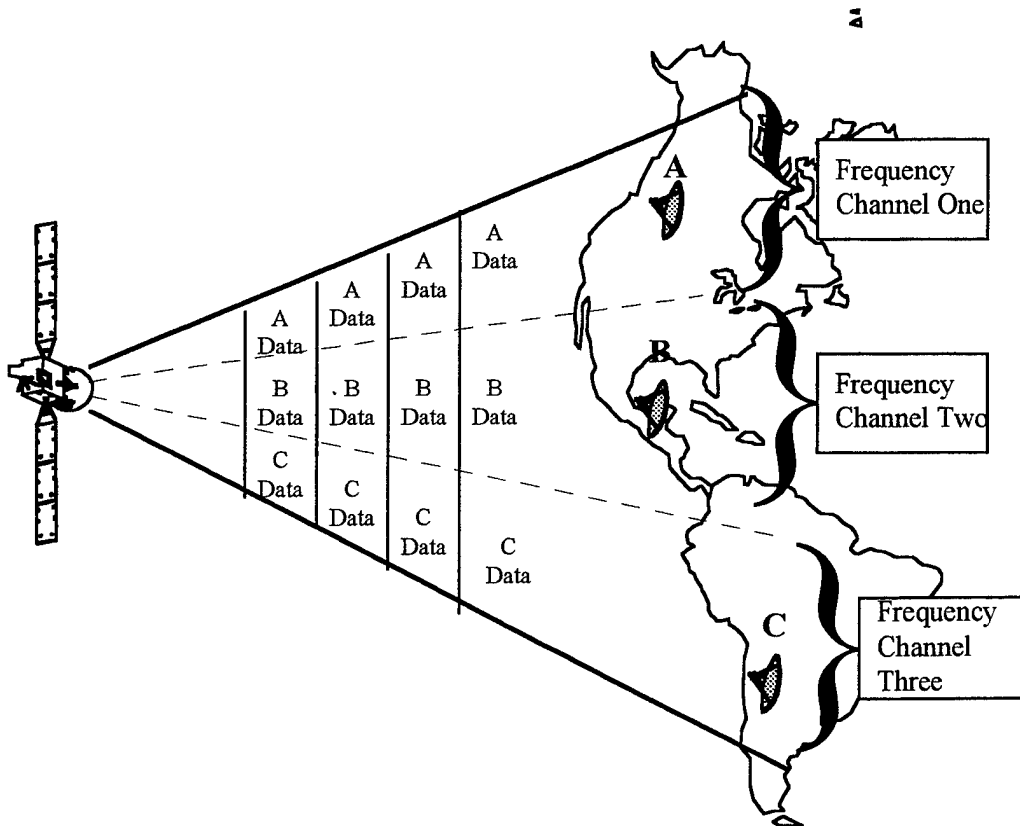

Figure 3-3. Frequency Division Multiple Access.

b. Time Division Multiple Access (TDMA)

TDMA allows many users to communicate on the same frequency but at different times. In TDMA, a single user is allowed to send a single signal to the satellite in a time interval called a time slot. At the end of this slot, another user repeats the process in the next time slot. This continues until all users have used at least one time slot. The aggregate total of these time slots is called a time frame, and this frame is then repeated. In this way, multiple users communicate on the same frequency, and avoid interference with each other by communicating at slightly different times. Figure 3-4 demonstrates the concept of TDMA. [Ref. 8: pp. 2-18, 2-19]

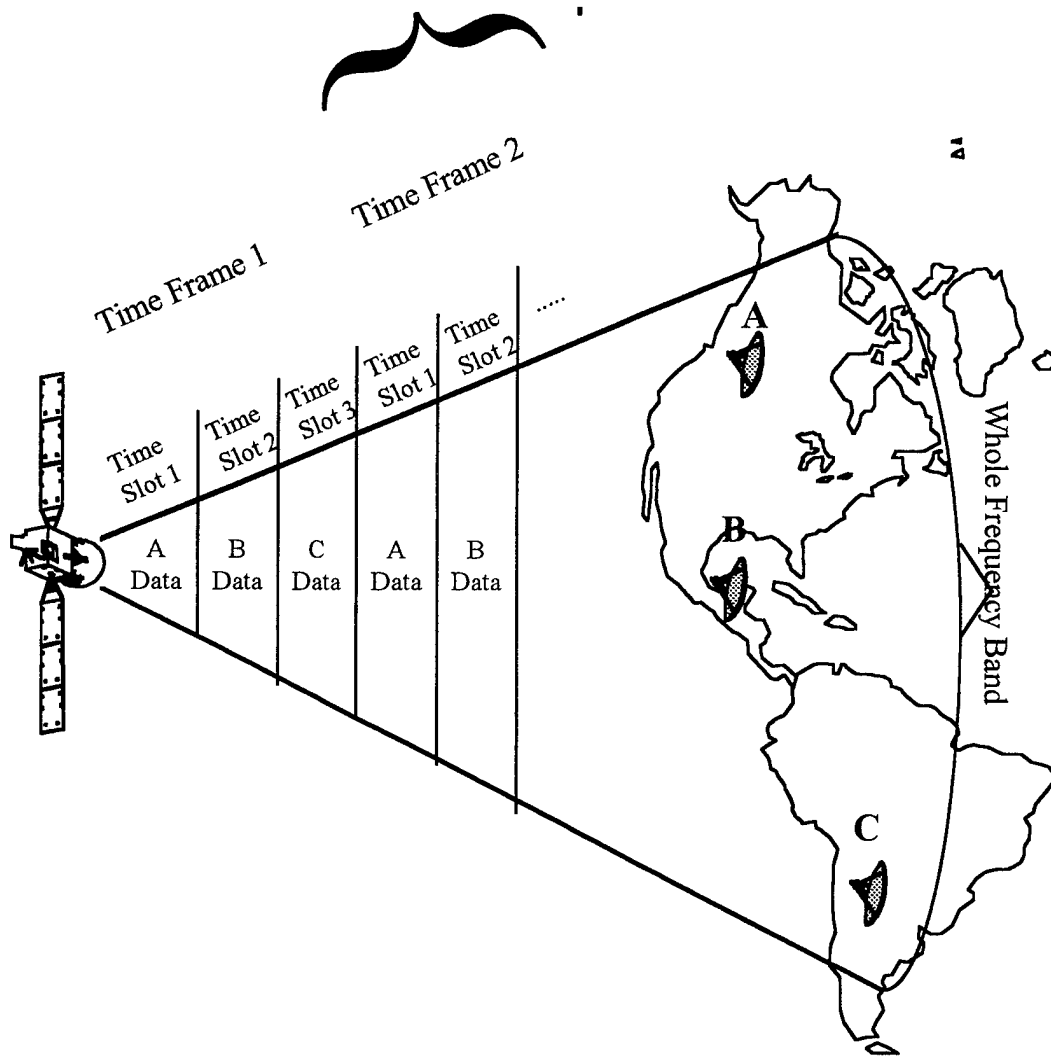

Figure 3-4. Time Division Multiple Access.

c. ***Code Division Multiple Access (CDMA)***

CDMA the signals of multiple users access the satellite simultaneously. Each signal uses the same carrier frequency and occupies the full carrier bandwidth, but the individual carriers are identified by means of a unique code assigned to them. The data is superimposed onto a specific coded address waveform. The combined signal is modulated onto a radio frequency carrier, producing signals that are “spread” across the

frequency bandwidth of the transponder. The CDMA receiving earth station is programmed to ignore all but signals carrying the correct code. CDMA's "spread" spectrum characteristics give it a distinct advantage in applications requiring LPI/LPD and jam protection. Figure 3-5 demonstrates CDMA and is followed by Figure 3-6 which compares the three multiple access schemes. [Ref 9: pp. 5-31]

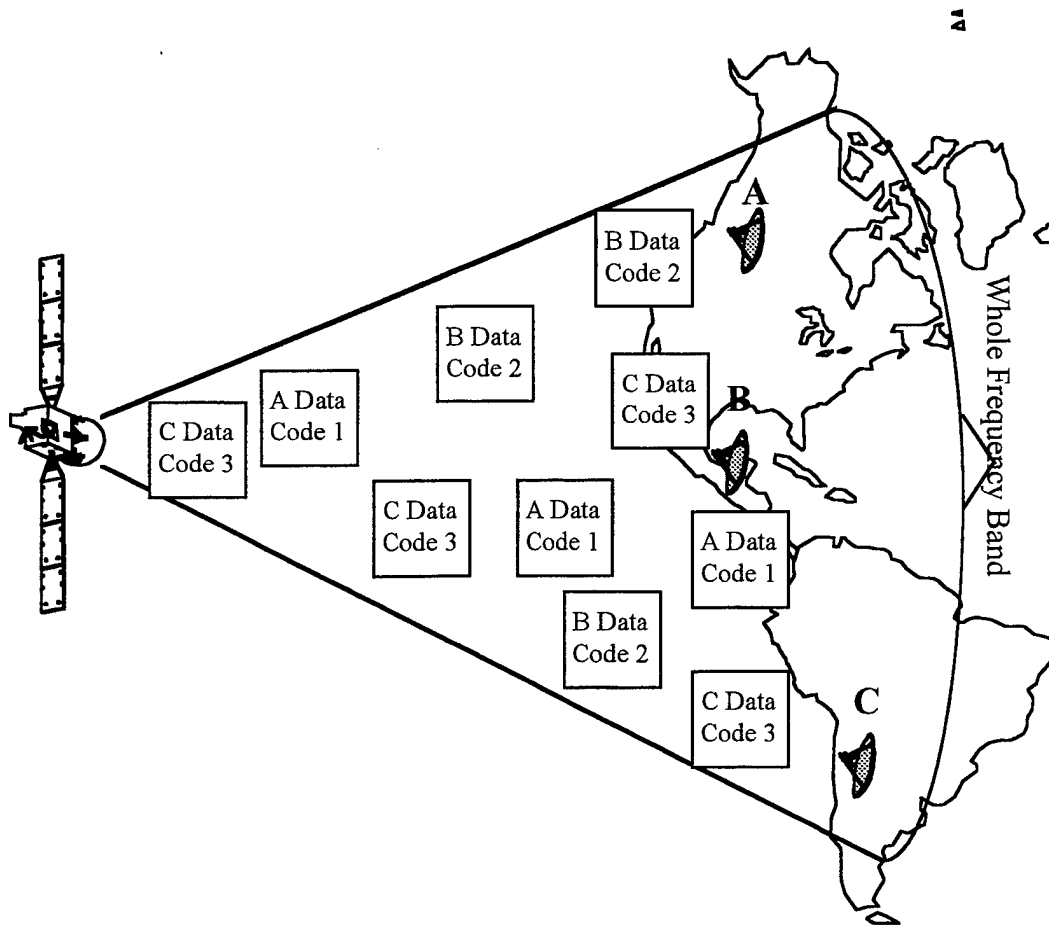

Figure 3-5. Code Division Multiple Access.

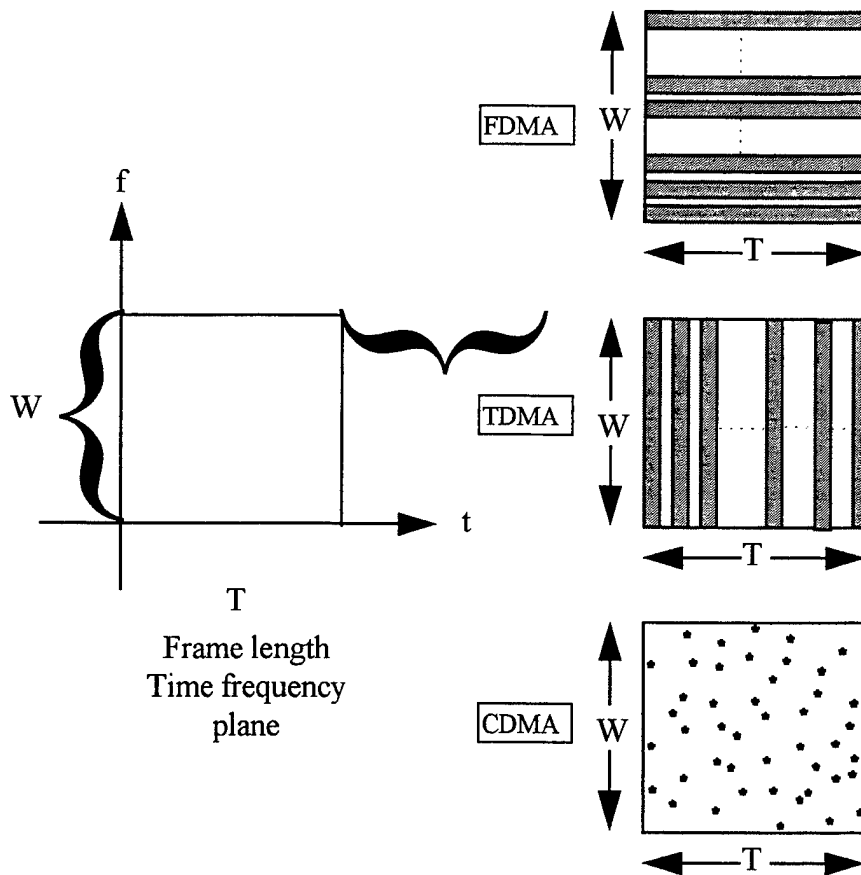

Figure 3-6. FDMA, TDMA and CDMA in the Time-Frequency Plane. From Ref. [10].

B. INMARSAT

1. System Overview

International Mobile Satellite Organization (Inmarsat) is a 79 member-state cooperative which operates a satellite system providing world wide (approximately 70° N latitude to 70° S latitude) telephone, telex, data and fax services to international shipping, aviation, offshore and land mobile industries. Inmarsat began in 1979 with the investment share of each member nation to be related to both the tonnage of ships registered and the volume of communications to and from it. The investment shares are adjusted yearly to

reflect the actual use of the system. In recent years, the major shares have been about 25 percent for the United States, 14 percent for the United Kingdom, 12 percent for Norway, and 9 percent for Japan. Comsat Corporation is the US representative in Inmarsat. Since Inmarsat began global operations, over 46,000 Inmarsat terminals have been sold and the demand is still rising. The Inmarsat system can be broken down into two segments -- space and ground. [Ref 11: pp. 116]

a. Space Segment

Inmarsat provides world wide satellite communications coverage from approximately 70° N to 70° S latitudes. Inmarsat's space segment is composed of a constellation of eight satellites in geosynchronous orbit located approximately at 55.5° W, 15.5° W, 64.5° E and 180° E longitude. The satellite coverage areas are the Atlantic Ocean Region West (AOR-W), Atlantic Ocean Region East (AOR-E), Indian Ocean Region (IOR), and Pacific Ocean Region (POR). The eight satellites are equally subdivided between the four operational areas with one active satellite and one on station spare at each location (Figure 3-7). [Ref 12: pp. 313]

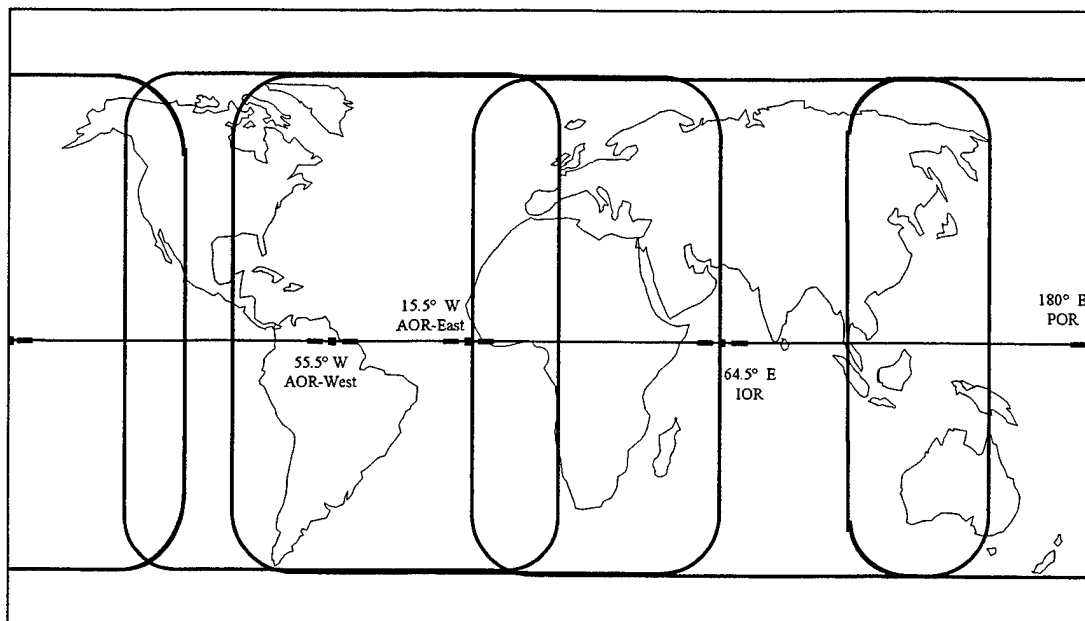

Figure 3-7. Inmarsat Satellite Coverage Areas. After Ref. [12].

Inmarsat's spare satellites are mainly composed of Inmarsat II satellites. Inmarsat II satellites use L-Band for communication with ships and C-band for communication with shore stations. Inmarsat II satellites use a hexagonal array of 61 elements to provide a global L-Band beam which can compensate for losses, which increase as the ship terminal elevation to the satellite decreases. For C-Band, each satellite has two seven-element arrays one for transmission and one for reception. One C/L-Band channel is used for shore to ship communications with 16 MHz bandwidth and four L/C-Band channels being used for ship to shore communications at 4.5 MHz bandwidths with a minimum of 25 dBW. The total capacity per satellite is 250 two-way voice circuits. Launched from between 1990 and 1992 each satellite has an estimated lifetime of 10 years, but with the introduction of the Inmarsat IIIs, Inmarsat IIs are being relegated to the roll of "hot spares". [Ref 11: pp. 111-112]

Inmarsat III satellites were not rushed into production because of the lifetime limitation of Inmarsat II, but by Inmarsat II's capacity limitations. With the interest in mobile communications on the rise, Inmarsat III satellites were developed to provide a capacity ten times that of Inmarsat II. Global, high power multiple spot beams will continue to support Inmarsat III types of services as well as provide newer mobile personal communications services and L-band to L-band communications via laptop size and smaller terminals. These spot beams will cover the majority of North America, South America, the Atlantic Ocean, Africa, Europe and the Far East (Figure 3-8).

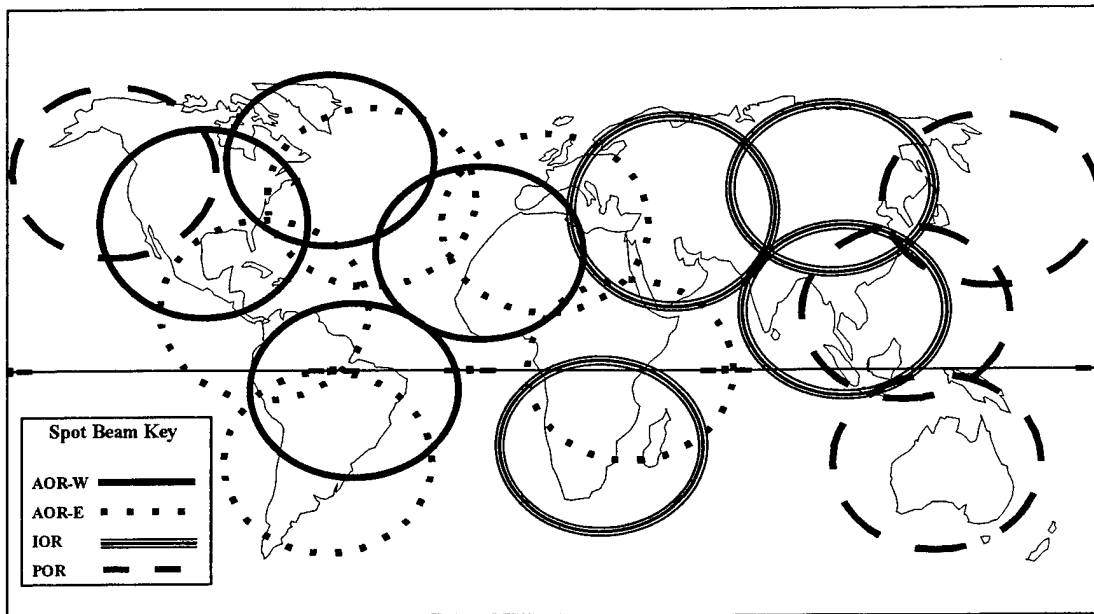

Figure 3-8. Inmarsat III Spot Beams. After Ref. [11].

A global spot beam was included to provide coverage between the spot beam coverage gaps and to provide to continued support for transoceanic users. The satellites will be able to re-allocate power and bandwidth between the five spot beams and the single global beam to dynamically meet changing traffic requirements. Each Inmarsat III satellite has a

design life of 13 years. Three Inmarsat IIIs are on station with the last satellite scheduled for launch late 1997. Inmarsat III's characteristics are described in Table 3-6. [Ref 11: pp. 113-115]

Configuration	Transmitter	Receiver	Antenna
<ul style="list-style-type: none"> - C-band to L-band forward channel, 19 bands with a total 64.5 MHz bandwidth - L-band to C-band return channel, 19 bands with a total 64.5 MHz bandwidth - C-band to C-band administrative channel, 0.9 MHz bandwidth. - L-band to L-band mobile channel. 1 MHz bandwidth - C-band to C-band and L-band navigation channel, 2.2 MHz bandwidth 	<ul style="list-style-type: none"> - C-Band: 3600 to 3629 MHz (L to C, and C to C), 3629.4 to 361.6 MHz (Nav). solid state power amplifiers. EIRP 27 dBW (I to C, and C to C), 0 dBW (Nav) - L-band: 1525 to 1529 MHz and 1530 to 1559 MHz (C to L, L to L), 1574.4 to 1576.6 MHz (Nav). Twenty-two solid state power amplifiers, 440 W total output (C to L, L to L). Redundant 17 W solid state amplifiers (Nav). EIRP 48 dBW split in any proportion between spot and global (C to L, L to L), 27.5 dBW(Nav) 	<ul style="list-style-type: none"> - C-Band: 6435 to 6454 MHz (C to L, C to C), 6454.4 to 6456.6 MHz (Nav). G/T -13 dB/K - L-band: 1626 to 1630.5 MHz and 1631.5 to 1660.5 MHz (L to C, L to L). One low-noise amplifier per antenna feed. G/T -11.5 dB/K (global beam), -5.5 dB/K (spot beam) 	<ul style="list-style-type: none"> - C-band: Two global coverage horns (1 transmit, 1 receive), each with dual circular polarization. - L-band: two offset fed deployed reflectors for global and spot beams (1 transmit, 1 receive), approximately 7.5 ft diameter, each with 22 cup-helix feeds, > 24.3 dB edge of coverage gain for spot beams (C to L) and > 19.2 dB peak gain for global beam (C to L, L to L), circular polarization; one 27 inch diameter center fed parabolic reflector (nav), 15.8 dB edge of coverage gain

Table 3-6. Inmarsat III Characteristics. After Ref. [11].

b. Ground Segment

The ground segment can be broken down into Ship Earth Stations (SES), Land Earth Stations (Gateways), Network Coordination Stations (NCS) and a Network Operations Center (NOC). The SES used by the Navy for shipboard mobile satellite services are Inmarsat A and Inmarsat B. Gateways are owned and operated by Inmarsat members, however Navy contracts exclusively with US owned and operated Comsat for

Inmarsat A and B services and routes its calls through one of Comsat's four Gateways. NCS are owned located at Fucino, Italy; Southbury, Connecticut; Santa Paula, California and Beijing, China. The NOC is located in London, UK [Ref 11: pp. 116]

The main difference between Inmarsat A and Inmarsat B is that A is an analog system and B is a digital system. The digital difference enables Inmarsat B to provide a substantial cost savings when compared to Inmarsat A. Additionally, Inmarsat B provides a path for future interoperability with Integrated Services Digital Network (ISDN). Both terminals perform similar functions, provide similar services and are of comparable size. The functions performed by Navy SES are reception and transmission of signaling messages, duplex telephony service, reception of Inmarsat Service Announcements, acknowledgment of shore-originated simplex call service, automatic distress testing capability, and priority request for establishing distress calls. Services provided by Inmarsat A and B are summarized in Table 3-7.

SERVICE	DATA RATE	NUMBER POSSIBLE
Voice	9.6 kbps	5
Facsimile	9.6 kbps	5
Telex	75 bps	740
Low Speed Data	9.6 kbps	5
High Speed Data	56 kbps	1
Video	56 kbps	1
Teleconferencing		
Compressed Video	56 kbps	1
Paging	1200 kbps	45
Broadcast/Group Calls	9.6 kbps	5

Table 3-7. Inmarsat A and B SES services. After Ref. [13].

Standard Maritime equipment for Inmarsat A and B SES include a 1016 mm stabilized parabolic directional antennae housed in a 1244 mm by 1350 mm radome, inside maritime equipment and the users equipment -- fax machines, PBX, phones, encryption devices, computers ... (Figure 3-9). [Ref 14: pp. 3]

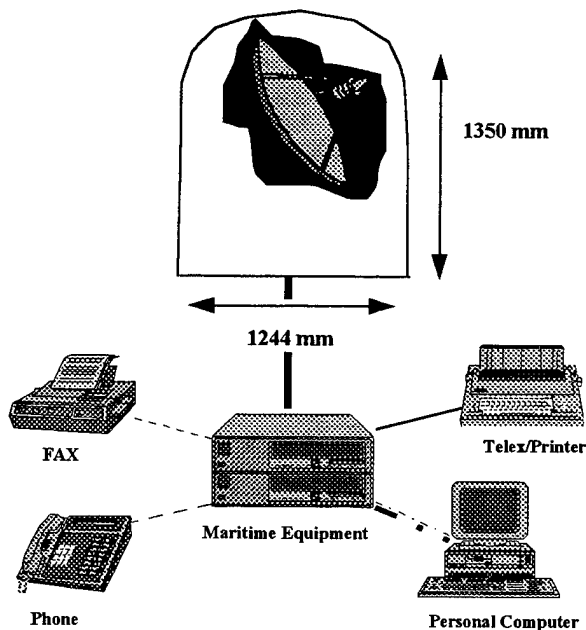

Figure 3-9. Inmarsat A and B Standard Configuration. After Ref [14].

Gateways process requests received from ships over a ship-to-shore “request” channel and from shoreside parties over the terrestrial trunks. For ship originated single channel per carrier (SCPC) calls the SES request message is received by the addressed Gateway which relays the request to the NCS for channel assignment; the NCS thereby assigns a channel in the appropriate satellite spot beam is available or a global beam channel is assigned if the appropriate spot beam frequency is not available. The NCS transmits the channel assignment to both the Gateway and SES. For shore

originated SCPC calls the Gateway requests the NCS to transmit a call announcement message to the required SES which then responds to the NCS. The NCS thereby assigns a channel in the appropriate satellite spot beam is available or a global beam channel is assigned if the appropriate spot beam frequency is not available. The NCS transmits the channel assignment to both the Gateway and SES. For ship originated TDMA calls, the SES request message is received by the addressed Gateway which then performs the assignment function and transmits the assignment message to the SES and NCS. For shore originated TDMA calls, the Gateway requests the NCS to transmit a call announcement message to the SES which then responds to the NCS. The NCS relays the SES response information to the Gateway which then performs the assignment function and transmits the assignment message to the SES and NCS. The Gateway provides support of duplex telephony, telex, transmission and reception of signaling messages, priority establishment, time slot assignments, requests frequency assignments, interstation signaling with the NCS, maintaining access control tables, commissioning SES installations, data reporting to Inmarsat and stand alone capability option in case of NCS failure. [Ref 15: pp. F-3]

Network Coordination Stations (NCS) are located at designated (collocated Gateway's and interface with the space segment at C-band and L-band for the purpose of signaling with SES and Gateways as appropriate and for overall network control and monitoring. NCS provides assignments for SCPC services and acts as back-up to Gateways handling ship originated distress calls. NCS monitors all signaling

channels received by the SESs. For spot beam operation the NCS carrier and spot beam identification are provided by the NCS bulletin board to permit spot beam identification for signaling units establishing calls. NCS transmits the NCS carrier for each spot beam to enable the SES to determine the appropriate spot beam identity. NCS determines the SES EIRP level on a call by call basis depending on the operational satellite; channel assignment in the spot or global beam and transmits the EIRP level in the assignment message. For TDMA channels the Gateway performs a similar function. The NCS processes all signaling messages (to Gateway and SES) on a first-come first-serve basis except those associated with priority distress calls. NCS functions include transmission and receptions of signaling messages, interstation signaling, channel assignment for SCPC, network monitoring, Maintain telephone and High Speed Data Service (HSD) list which indicates which channels are in uses as well as Gateway and SES using each channel. [Ref 15: F-4]

The Network Operations Center (NOC) is located at Inmarsat Headquarters located in London, UK. At that facility the capability exists for centralized monitoring provided by the monitor and test capabilities of Inmarsat's NCSs. NOC typically provides resource allocation of the space segment resources to NCS and Gateway earth stations where required. [Ref 15: pp. F-5]

2. System Strengths

The Navy has contracted Inmarsat services through US signatory Comsat since 1990. Article 3(3) of the Inmarsat Convention states that Inmarsat Organization 'shall act

exclusively for peaceful purposes". While at first glance "peaceful purposes" may seem to preclude military use of Inmarsat services, it has been determined that "peaceful purposes" does not exclude military activities so long as those activities are consistent with the UN Charter. This interpretation has allowed Inmarsat to install SES aboard warships. Currently, Inmarsat SESs are installed in over 150 Navy ships. In the near future, every ship in the Navy from FFGs to CVNs will be outfitted with at least one Inmarsat SES. Inmarsat SESs have proven their usefulness in providing direct dial phone services, high quality images, video conferencing, video products, BDA reports and weapons targeting in numerous Navy operations from the Gulf War to operations in Bosnia and beyond. [Ref 16: pp. 1]

COMSAT earth ground stations are located in Santa Paula CA (Pacific Ocean and Western Atlantic satellite), Southbury, CT (Western and Eastern Atlantic satellites), Anatolia, Turkey (Eastern Atlantic and Indian Ocean satellites) and Eurasia, Thailand (Indian Ocean and Pacific Satellites). The COMSAT ground stations are all linked via fiber optic cables. A Navy vessel's Inmarsat SES call is routed through one of these COMSAT owned ground stations, relayed via fiber optic cable to another Comsat owned gateway, over another Inmarsat satellite if the vessel is making a ship to ship call, relayed on to a Conus gateway where call will be routed either to a leased line or the public switched telephone network depending on the calls ultimate destination (Figure 3-10). [Ref 13: pp. 3-5]

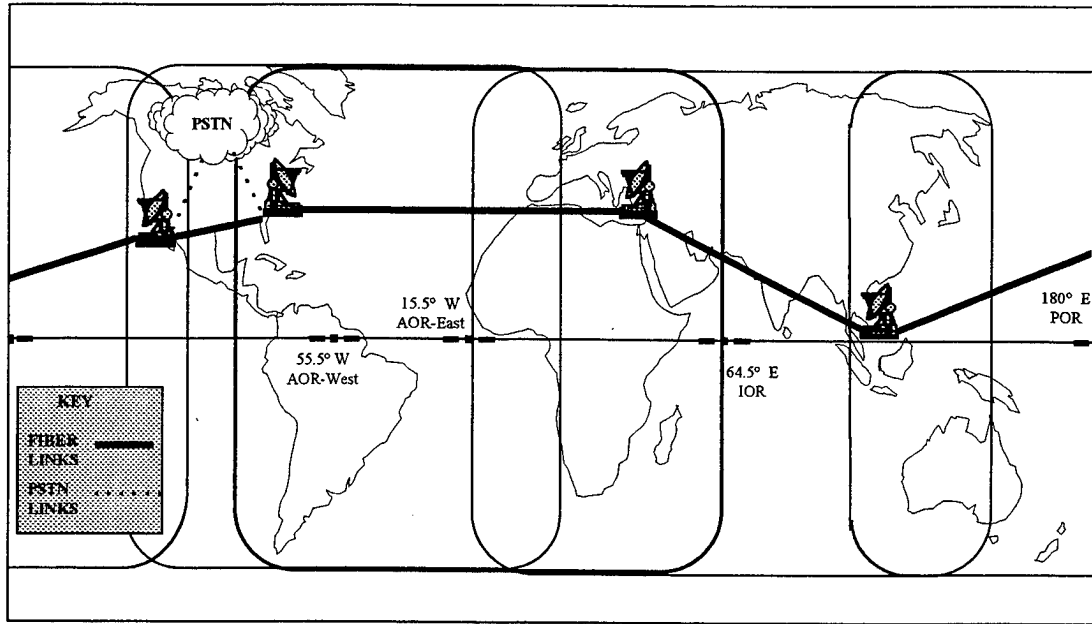

Figure 3-10. Comsat Fiber Relay Network. After Ref. [17].

The closed network formed by the Comsat fiber relay network provides the Navy with a more secure mode of communications between its widely dispersed forces rather than having to rely on numerous foreign owned Gateways. The Navy is the single largest user of Inmarsat services and is allied with Comsat, Inmarsat's largest shareholder. These two factors reflect positively on the Navy obtaining new services and being able to modify existing services to better meet its needs. For example, the Navy has been encrypting data passed over Inmarsat utilizing a STU III encryption device connected to the analog Inmarsat A something it would not be able to do over the new all digital Inmarsat B. At no additional research cost to the Navy, Comsat identified the problem and began work with governmental agencies to ensure STU III technology would be incorporated in

Inmarsat Bs. Table 3-8 describes a number of requirements which Comsat helped the Navy satisfy with existing, modified or new services. [Ref 17: pp. 4-5]

Requirement	Service
Netted Communications	Group Calls
Telemedicine	High Speed Data Service (HSD)
Battle Damage Assessments	HSD
Video Teleconferencing	Compressed Video via HSD
GENSUR & SI Message Rebroadcast	Broadcast
Situation Awareness	Rebroadcast Compressed Video of CNN
Logistics Support	Low Data Rate Service used for SALTS
Weapons Data	HSD
Moral Welfare Recreation	AFRTS Radio Bcast/Sailor Phone

Table 3-8. Navy Requirements Satisfied by Inmarsat.

3. System Weaknesses

Inmarsat's weaknesses are inherent in most commercial systems. Those weaknesses are cost of service, assured access and system vulnerabilities. The cost of Inmarsat's services depends on data rate and on whether you are calling ship to ship, ship to Conus or ship to out of Conus. Naturally, the higher the data rate the more bandwidth you need so the more you pay. A ship to ship direct call will add the greatest cost as it involves at least one gateway and two satellite hops -- ship to satellite to gateway to satellite to ship. A ship to out of Conus is the next highest on the cost scale as Comsat fiber network brings the call back to the US and into the public switched network for one fee with an additional charge being added for the international call from Conus. Finally, a ship to Conus call will be the lowest flat rate with no hidden charges as once the call is in

the US no additional charge will be assessed. The cost of Inmarsat A's all analog services is substantially higher than the cost for Inmarsat B's all digital services and is a driving factor in the Navy's decision to replace all Inmarsat As over the next five years. Table 3-9 compares the costs associated with Inmarsat A and B services. [Ref 18: pp. 2-5]

PRODUCT	INMARSAT A COST	INMARSAT B COST	DIFFERENCE
Voice /Low Data Rate/Fax Service (* add cost of long distance if overseas call)			
Ship to Conus	\$5.90/min *	\$2.85/min*	\$3.05/min*
Ship to Ship	\$11.90/min	\$4.35/min*	\$7.55/min
High Speed Data Service (* add cost of long distance if overseas call)			
Simplex Ship to Conus	\$7.90/min*	\$5.95/min*	\$1.95/min*
Simplex Ship to Ship	\$15.80/min	\$11.90/min	\$3.90/min
Duplex Ship to Conus	\$11.25/min*	\$9.00/min*	\$2.25/min*
Duplex Ship to Ship	\$22.50/min	\$18.00/min	\$4.00/min

Table 3-9. Inmarsat A and B Service Costs.

Access with Inmarsat as with all commercial systems can be a potential problem unless you lease or buy a transponder. Otherwise, you must compete for access on an equal basis with other paying Inmarsat customers. If the satellite or Comsat Gateway are overloaded the caller will get a busy signal until a channel becomes available to them. Over open ocean, access is readily available. However near a busy coastline or in a remote hot spot with little terrestrial infrastructure assured access is tenuous at best. Inmarsat historically has had a very good access rate, meaning when you want to make a call you can, of between 95 and 98 percent in off areas and 85 to 93 percent in congested areas. These rates will become even better over the next few months as the remaining

Inmarsat IIIs come on line with their fixed spot beams and ability to reallocate bandwidth and power dependent on traffic patterns. [Ref 9: pp. 30-33]

Commercial satellites are vulnerable to threats of hostile jamming, detection interception and geolocation because the commercial world trades protection for bandwidth. Jamming of a geosynchronous satellite can be done with components obtained from a local electronics store as was proven when a gentleman in the US jammed an cable company satellite channel using a microwave and a trash can lid. Detecting a TDMA and FDMA signal can be easily done with the correct location, a little knowledge and a spectrum analyzer. With a little more effort, interception can also be accomplished, however, STU III encrypted information would be unintelligible. Finally, geolocation would take much more skill and effort on the part of an adversary, but remains well within the abilities of many. In fact, Inmarsat provides additional help for the adversary attempting to geolocate or track Navy ships at sea. If a ship leaves their Inmarsat on after completion of a call, the ship can be geolocated to under a hundred miles simply by someone calling the ship and receiving a ring back. [Ref. 8: pp. 2-18 , 2-19]

B. IRIDIUM

1. System Overview

Motorola pioneered the idea of a Low Earth Orbit (LEO) system which would provide worldwide telephone service providing a dial tone anywhere at anytime. The original concept as visualized in 1988 contained 77 Satellites. Hence the name "Iridium" was selected, since the element iridium in the periodic table has the atomic number 77.

The name has stuck even though the number of active satellites has been reduced to 66 with a System Control Segment, gateways, intersatellite links and handheld phones completing the system. Iridium Inc. is an international corporation with US based corporation Motorola maintaining the largest share (18%) with the remaining shares (83%) divided between other corporations in the United States, Africa, Canada, China, India, Middle East, South America, Russia, South Korea, Japan, Taiwan, Italy, Thailand and Germany. Iridium was granted a full Federal Communications Commission (FCC) license in January, 1995 for operations in the United States with landing rights around the world being successfully negotiated separately with host nations. Launch services are being provided by China, Russia and U.S. based launch facilities. Motorola, Lockheed-Martin, Raytheon COM DEV, Bechtel, Scientific Atlanta and Siemens are producing Iridium system components. Initial launch dates have slipped until the spring of 1998. Projected initial operational capability (IOC) is the fall of 1999 with full operational capability not expected until fall 2000. [Ref. 19: pp. 1-2, 5-6]

The Iridium system uses Groupe Special Mobile (GSM) telephony architecture to provide a digitally switched telephone network enabling global roaming. A subscriber will be assigned a personal phone number. The Iridium system determines the user's location and in turn the network charges at the appropriate rate for that location will be levied on that personal phone number. Besides voice traffic, Iridium will support paging data traffic and facsimile. Iridium's key system design feature is a constellation of low earth orbiting satellites interconnected with four crosslinks per satellite creating a call routing network in

the sky minimizing the number of satellite to earth hops thereby minimizing path delay. The Iridium phones -- called Subscriber Units (SU)-- will be capable of operating in a "dual mode" to enable the use of lower cost compatible terrestrial cellular networks where available. Additional services offered by Iridium are mobile exchange units and solar powered phone booths for multiple users in remote locations. Figure 3-11 depicts the Iridium system architecture, the components of which will be discussed in greater detail in subsequent paragraphs. [Ref. 20: pp. 483-484]

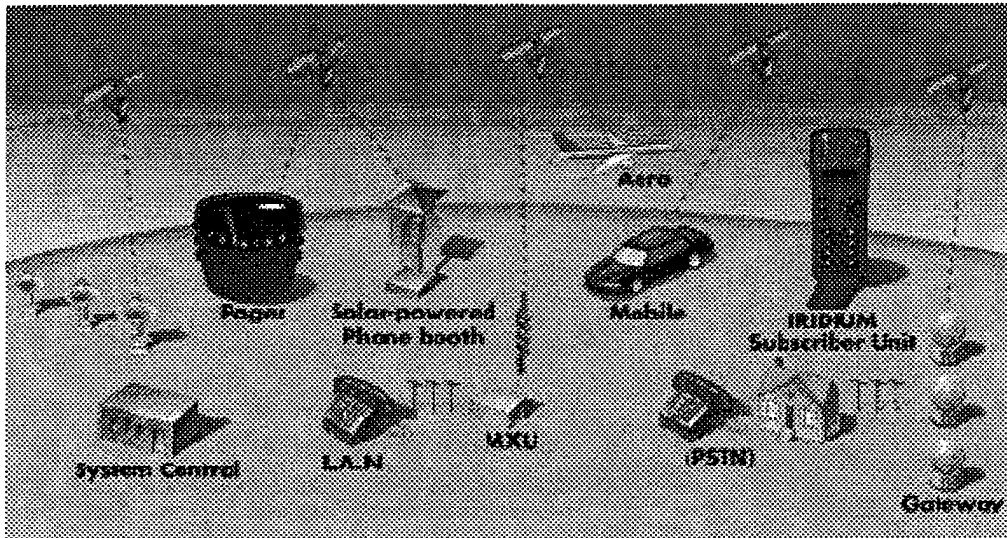

Figure 3-11. Overview of Iridium System. From Ref. [21].

a. Space Segment

Sixty-Six operational satellites are configured in six orbital planes with an inclination of 86.4° and 11 satellites plus one on-orbit spare in each plane. This allows Iridium to cover all areas of the Earth (see Figure 3-12). The satellites are phased

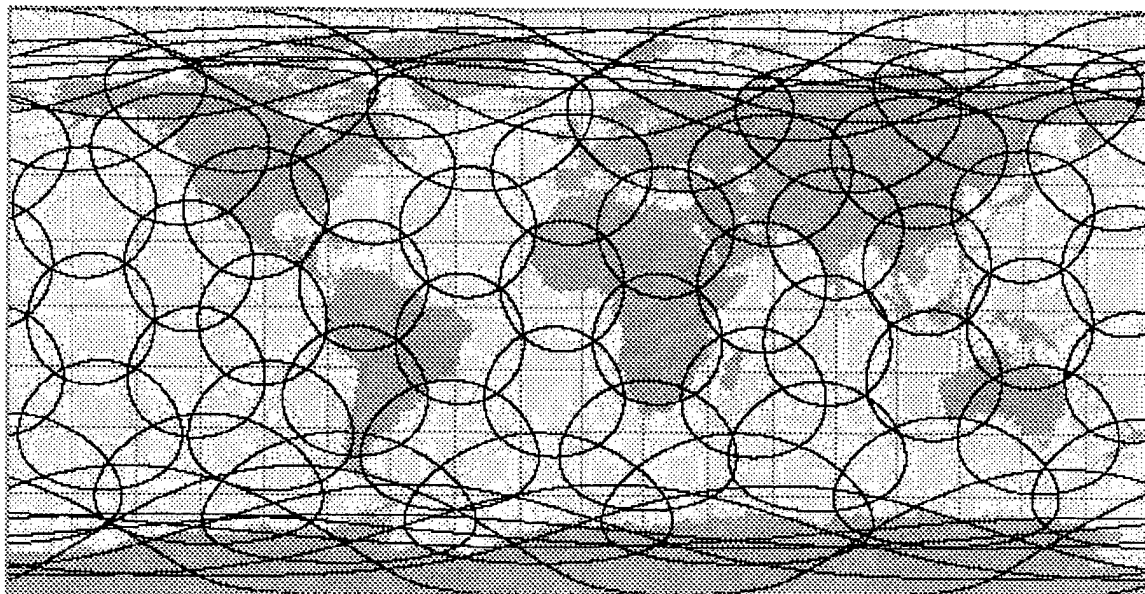

Figure 3-12. Iridium Instantaneous Coverage Areas. After Ref. [22].

appropriately in co-rotating planes up one side of the earth, across the poles, and down the other side of the earth. These co-rotating planes are separated by 31.6 degrees. The satellites orbit at a mean altitude of 780 km (see Figure 3-13).

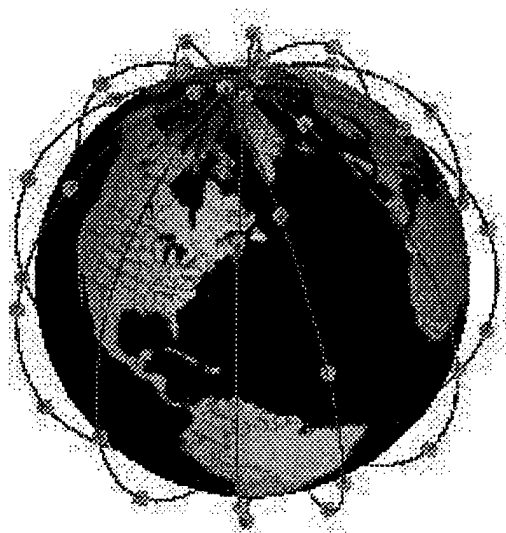

Figure 3-13. Iridium Satellite Constellations. From Ref. [23].

Full Earth coverage is enabled by three L-band antennas which form a honeycomb pattern of 48 beams below each satellite. As the satellite beam footprint moves over the ground, the subscriber signal is switched from one beam to the next or from one satellite to the next in a hand-off process. As the satellites approach the poles, their footprints converge and the beams overlap. [Ref. 24: pp. 4.15-4.16]

All routing is done completely by the space network enabled by Iridium's crosslink technology. Iridium is the first mobile satellite system to incorporate sophisticated digital onboard processing on each satellite and the crosslink capability between satellites (see Figure 3-14).

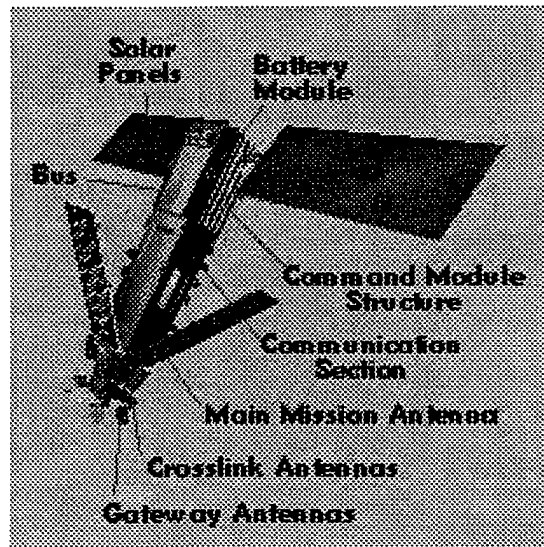

Figure 3-14. Iridium Satellite. From Ref. [21]

The four crosslinks, and the feeder links connecting satellites to gateways, operate at K-Band frequencies. These intersatellite links together with the gateway links operate in packetized Time Division Multiplexing mode. The service links connecting subscriber

units to the satellites operate in L-Band frequencies in the narrowband TDMA/FDMA mode (see Figure 3-15).

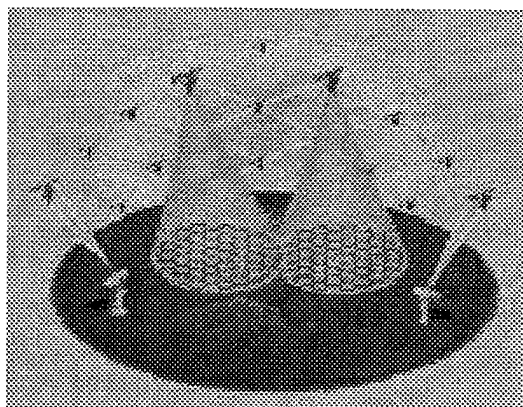

Figure 3-15. Iridium Satellite Links. From Ref. [21].

The L-Band communication service links operate in the 1610-1626.5 MHz band. The total occupied bandwidth is 5.15 MHz. Modulation is quadrature phase shift key (QPSK). With 80 circuits per beam 48 beams per satellite 3,840 circuits are possible per satellite. With a total of 66 satellites in the system 253,440 channels are possible with 1.2 Gbps being the total system throughput possible. Both uplinks and downlinks operate in the L-band, using Time Division Duplexing (TDD). All K-Band links--uplink, downlink, and crosslinks--are packetized TDM/FDMA using QPSK modulation. Coded data rates for the gateways and satellite control facility links are 6.25 Mbps, with the crosslinks operating at a higher data rate of 25 Mbps. Crosslinks allow for reduced ground infrastructure requirements, enable least cost routing, and permit full global coverage (including the oceans). Iridium's satellite frequency bands are described in Table 3-10. [Ref. 24: pp. 4.20-4.25]

Type of Link	Frequency Bands
K-Band Down-Links	18.8-20.2 GHz
K-Band Up-Links	27.5-30.0 GHz
K-Band Crosslinks	22.55-23-55 GHz
L-Band Service Links	1610-1626.5 MHz

Table 3-10. Iridium Satellite Frequency Bands.

b. Ground Segment

The ground segment consists of system control segment, gateway segment and user segment. The system control segment is composed of the mission control facility (MCF), the system engineering control facility (SCF) and the system control sites (SCS). The mission control facility is responsible for operation and control of the Iridium's satellites. Initially, Chandler, Arizona will handle MCF responsibilities for the first 40 satellites before transferring control to Lansdowne, Virginia. Chandler, Arizona will then revert to its primary mission as a SCF responsible for providing engineering support and anomaly resolution. The final portion of the system control segment, SCS, functions as the conduit between the satellite and the MCF. Iridium satellites will always remain in contact with one of the SCSs in the network. Telemetry data will be sent directly from the satellite to an SCS which will then relay the data to the MCF. There are two primary SCSs in Canada one of which provides the additional function as Iridium's main gateway keeping track of all Iridium's billing information. A SCS located in Waimea, Hawaii will be used by the SCF during the launch phase. Other SCSs include Rome, Italy which also

functions as a backup MCF and additional deployable SCSs are available in Iceland. [Ref. 20: pp. 485-486]

The gateway segment is designed to interconnect the constellation with the Public Switched Telephone Network (PSTN). A gateway is intended to handle call set-up, caller location and collection of necessary data to support billing. Caller location is necessary because an Iridium SU can be carried anywhere in the world. The SU, when powered on, is being designed to communicate to the nearest satellite which will then notify the access control processor which updates updates the location register of the home gateway. Access to the system is to be controlled geographically to help prevent communications between locations that are barred by the controlling regulatory administration. This access is to be controlled by determining the user's location during the call set up process and correlating it with the user's home and call destination. This process is transparent to the user but is necessary for regulatory purposes. Connection to the PSTN allow calls to be placed not only from one Iridium subscriber to another, but also to and from any Iridium SU to any PSTN connected device. Gateways will use two to four 3.3 meter antennas. At least two antenna terminals are needed with one always acquiring the next spacecraft with additional antennas being used for backup. GSM telephone architecture and Iridium's geographic-controlled system permits backup arrangements between gateways to safeguard against catastrophic events. The Iridium system could provide service with only one Gateway worldwide. However, when fully

implemented, the Iridium system will have over 20 gateways distributed around the globe.

[Ref. 24: pp. 4.15-4.25]

IRIDIUM PHONE

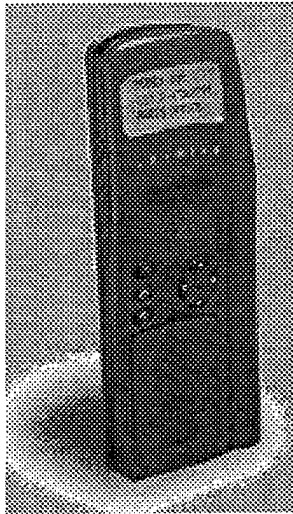

IRIDIUM PAGER



Figure 3-16. Iridium Handheld Phone and Pager. From Ref. [21].

Subscriber units will come in a variety of shapes and sizes depending upon their functions (see Figure 3-16). Initial development includes the handheld unit, mobile unit to be installed in autos, planes, boats... and a variety of paging products with an estimated cost of between \$2,000.00 and \$3,000.00. The services provided by these SUs will be voice/data, paging and fax. Through dual-mode handheld telephones, an Iridium subscriber has use of both a local terrestrial system (where available) and an Iridium satellite overhead a user can transmit high quality voice, data and fax at 2.4 kbps 24 hours a day from anywhere on earth. Iridium pagers are an even smaller SU which will be able to receive and store alphanumeric messages on a global scale. These SUs are currently designed to operate for 24 hours on a single recharge with a combination of standby (able

to ring) and active modes. Access to the Iridium satellite constellation will cost approximately \$3.00/min and will be through L-Band cellular links using FDMA/TDMA techniques and a low profile antenna which receives and transmits at power levels comparable to those of handheld cellular telephones. The quality of voice communication is directly related to the vocoder (digital voice encoder) selected. Currently, several high-quality vocoder's can be used to produce voice recognition quality though not emotion sensitive transmissions at a data rate of 2.4 kbps. Figure 3-17 demonstrates how Iridium would handle an Iridium SU to PSTN call. [Ref. 25: pp. 1-10]

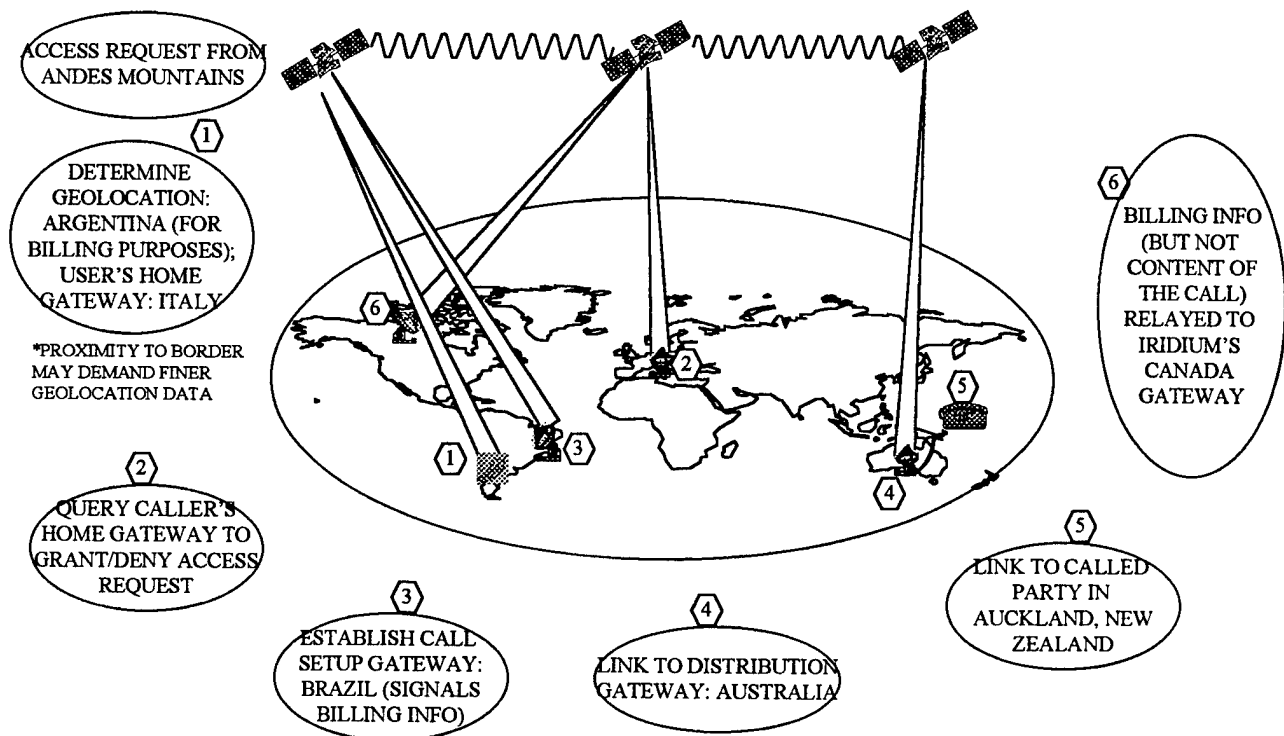

Figure 3-17. How Iridium Handles a Handset to PSTN Phone Call. After Ref. [25].

2. System Strengths

Iridium's strengths are their handsets (cost, portability, temporary terminal ID and dual mode) crosslinks (global coverage and failure resistant) geolocation and head start in the PCS market. The cellular phone size and weight of Iridium's handset provide the user with unlimited mobility allowing them to be carried to any where in the world. Even at the high end of \$3,000.00 per handset, terminal costs are more than reasonable when compared to military and other commercial terminals which cost upwards of \$40,000.00 apiece. Handsets also do not broadcast their terminal ID's over open frequency which could be intercepted and spoofed by others. Instead, Iridium handsets use a complicated cryptographic system which assigns each user a new temporary ID every time the phone is used. The temporary ID is then correlated at the user's gateway who identifies the user as a valid caller to the Iridium network and the call set up process proceeds unhindered. The dual mode of Iridium handsets allows the user the flexibility to use a cheaper terrestrial network when within its service area and to use the more expensive Iridium network when no terrestrial network is available. [Ref. 24: pp. 4.30]

Iridium's crosslinks provide the unique capability of being able to call from any point on the face of the earth and reach any other corresponding point without the call ever intervening terrestrial links. Figure 3-17 demonstrates the process. The only information passed to the various ground sites only concern the call setup, not the call content. An additional benefit to Iridium's crosslinks and onboard switching capabilities is

the ability to withstand a satellite failure. Traffic can be routed around satellites which fail due to natural or unnatural causes, keeping the network viable. [Ref. 25: pp. 5]

Geolocation, which is built into Iridium, can provide a useful service to Navy users. The geolocation will have to be accurate enough to identify what country a user is calling from in order to pay that country's portion of the Iridium usage fee. The granularity of geolocation will have to be less than five miles. At that level of accuracy, the Navy could develop uses for the system such as geolocating downed pilots at sea. [Ref. 25: pp. 6]

Iridium has been working the PCS issue since 1988, has built a good portion of its ground infrastructure, has secured enough financing for IOC, has developed various subscriber units, negotiated landing rights worldwide and has secured its first successful launch of its first five satellites on May 5, 1997. Even with launch setbacks and other unexpected occurrences, Iridium should be providing worldwide cellular services by 1999. This head start gives them the edge in developing a strong customer base before its competitors enter the market.

3. System Weaknesses

Iridium shares weaknesses with most other commercial satellite systems – assured access, cost of service and system vulnerabilities. Assured access with Iridium cannot be guaranteed. The system supports only 253,440 total channels worldwide. Only 3840 circuits are available in a satellite footprint the approximate size of the United States. Within that footprint, each the approximate size of Arizona, are 48 cells which can handle

up to 80 circuits. Consider the UN operations in Bosnia. Given that Bosnia's size is comparable to Arizona's, the thousands of peace keeping forces operating there would have access to no more than 80 circuits which, by the way, they must share with anyone else in the area equipped with a valid Iridium SU.

Cost of service at the standard rate of \$3.00/min would be cost prohibitive for a number of potential Naval uses. If netted communications were possible, using Iridium for any but the most critical networks would be difficult to justify due to the excessive cost. Table 3-11 presents a sample scenario for using Iridium in a netted mode, assuming one network and varying the number of users from 2 - 10 for a 24 hour operation:

Number of Users	Cost/min	Number Hours	Total Cost
2	3.00	24	\$8,640.00
4	3.00	24	\$17,280.00
6	3.00	24	\$25,920.00
8	3.00	24	\$34,560.00
10	3.00	24	\$43,200.00

Table 3-11. Example of Iridium Costs for Netted Communications.

Considering that in a theater of operations you would have hundreds of networks which would have to be established, the cost for netted communications alone would be prohibitive. For a 30 day operation with only 100 networks and a limit of 10 per network, a total cost of \$129,600,000.00 would be incurred just for those maintaining those networks using Iridium. [Ref. 24: pp. 4.50]

System vulnerabilities include high probability of detection and interception, jamming, unencrypted data interception, exploitation of gateways and use of geolocation

data by adversaries. Iridium relies on TDMA and FDMA for access to its satellites. Both access methods are easy to detect and intercept. TDMA and FDMA produce signals which can easily be exploited by utilizing spectrum analyzers readily available from numerous commercial sources. The Iridium system out-of-the-box only encrypts the temporary ID, not the voice/data being passed by the systems. Again, in order to intercept the unencrypted signals, all that would be required is to be within line of sight of the Iridium emitters and to obtain a few components from the local electronics store. In order to jam a cell, an adversary would require a jammer capable of jamming across 845 kHz range which is not technically challenging [Ref. 24: pp. 4.55]

The multiple gateways through which the call setup data must pass (see Figure 3-17) represent a number of potential vulnerabilities. The billing information, which includes geolocation data, call source/destination and call duration, could be exploited and prove to be detrimental to Naval forces. Geolocation data could be intercepted at a gateway and used to geolocate Naval forces. Call source/destination combined with call duration information could be exploited using traffic analysis techniques to provide Navy adversaries with vital intelligence on Naval forces structure and disposition. Control of one of the gateways which a user's call setup approval must pass could enable an adversary to prevent connection by a valid user by falsifying or corrupting call setup data. [Ref. 24: pp. 4.56]

C. GLOBALSTAR

1. Overview

Originally proposed in 1986 by Ford Aerospace to provide mobile satellite communications services to automobiles, Globalstar, founded in 1991, has evolved into a world-spanning wireless mobile and fixed voice, data and facsimile telecommunications system. Globalstar is a low-earth-orbit (LEO) satellite based mobile communications system which provides quality LDR wireless communications (voice and/or data) anywhere in the world from 70°S to 70°N latitudes except areas without gateways. The Globalstar system is composed of 48 "bent pipe" satellites local gateways, Ground Operations Control Centers(GOCC), Satellite Operations Control Centers SOCC, Globalstar Data Network (GDN) and Subscriber Units (SU). Globalstar LP is an international limited partnership who will sell access to a worldwide network of regional and local service providers. Loral Space and Communications a U.S. based company maintains the largest share at 33% international strategic partners from United States, France, Germany, Italy and South Korea maintain a 49% share with the remaining 18% held publicly. Globalstar was granted a full FCC license in November 1996 and worldwide feeder and user link frequencies being approved by the International Telecommunications Union in November 1995. Launch Services will be provided by McDonnell Douglas, St. Louis, Missouri, will launch eight Globalstar satellites aboard two Delta II rockets, NPO Yuzhnoye, Kiev, Ukraine, will launch a total of 36 Globalstar satellites on three Zenit-2 launch vehicles and, Starsem, Suresnes, France, will launch 12

Globalstar satellites aboard three Soyuz launch vehicles. Table 3-12 describes component responsibilities. Projected IOC of 24 satellites is projected for fall 1999 with full operational capability not expected until fall 2000. [Ref. 26: pp. 1-10]

Strategic Partner	Globalstar System Component
Alcatel	Satellite Communications Equipment
Alenia	Final Assembly, Integration and Testing of Satellites
DASA	Satellite Power Propulsion Elements and Solar Arrays
Hyundai	Satellite Electronic Components
Loral Space & Communications	Overall Management, design construction and operations.
Qualcomm	Design and Manufacture of SUs and GOCCs (provides proprietary CDMA and position location technologies)
Space Systems Loral	Construction of Satellite Constellation
AirTouch	Service Provider for US, Indonesia, Japan, Malaysia, Portugal Austria Netherlands, Switzerland and Belgium
DACOM	Service Provider for Taiwan, India Thailand, Pakistan, South Korea, North Korea, Hungary, Chile and Finland
France Telecom	Service Provider for Venezuela, Peru, Uruguay, Argentina, Columbia, France, Poland, Czech Republic, Spain, Morocco, Algeria Tunisia, Egypt, Lebanon, Vietnam, Cameroon, Central African Republic, Congo, Gabon, Ivory Coast and Senegal
Vodafone Group	Service Provider for Australia, Sweden, South Africa, Greece, Denmark, Malta, Hong Kong and UK
Elsag Baily	Service Provider for Italy, Serbia, Slovenia, Croatia, Albania, Romania, Bulgaria, Ukraine, Moldavia and Macedonia
Local and Regional Service Providers	Provide Remaining Services to Respective Localities (China, Russia...)

Table 3-12. Strategic Partners System Component Responsibilities. After Ref. [26].

The Globalstar System uses CDMA technology for efficient power and spectrum usage bent pipe satellite transponders, multisatellite user links (3 optimum) and soft hand-off between satellites to provide worldwide mobile service. The SUs have a dual mode capabilities to enable the use of lower cost compatible terrestrial cellular networks where

available. Where not available, a satellite (or multiple satellites) will relay the SU's signal to a local Gateway in the same footprint who will handle the users call and add additional PSTN usage costs. Key capabilities provided by Globalstar are low cost usage (approximately .60 cents/min), CDMA (increased quality and privacy) link, position location and multiple satellite coverage (path diversity which is resistant to blockage). The Globalstar system will provide voice, data, fax, and other telecommunications services to users worldwide. The Globalstar system is designed to complement and extend, not replace, existing Public Switch Telephone Network (PSTN) and Public Land Mobile Network (PLMN) infrastructure. Users of Globalstar will make or receive calls using hand-held or vehicle mounted terminals similar to today's cellular phones. Calls will be relayed through the Globalstar satellite constellation to a ground station, and then through local terrestrial wireline and wireless systems to their end destinations. Figure 3-18 depicts the Globalstar system architecture, the components of which will be discussed in greater detail in subsequent paragraphs. [Ref. 27: pp. 1-6]

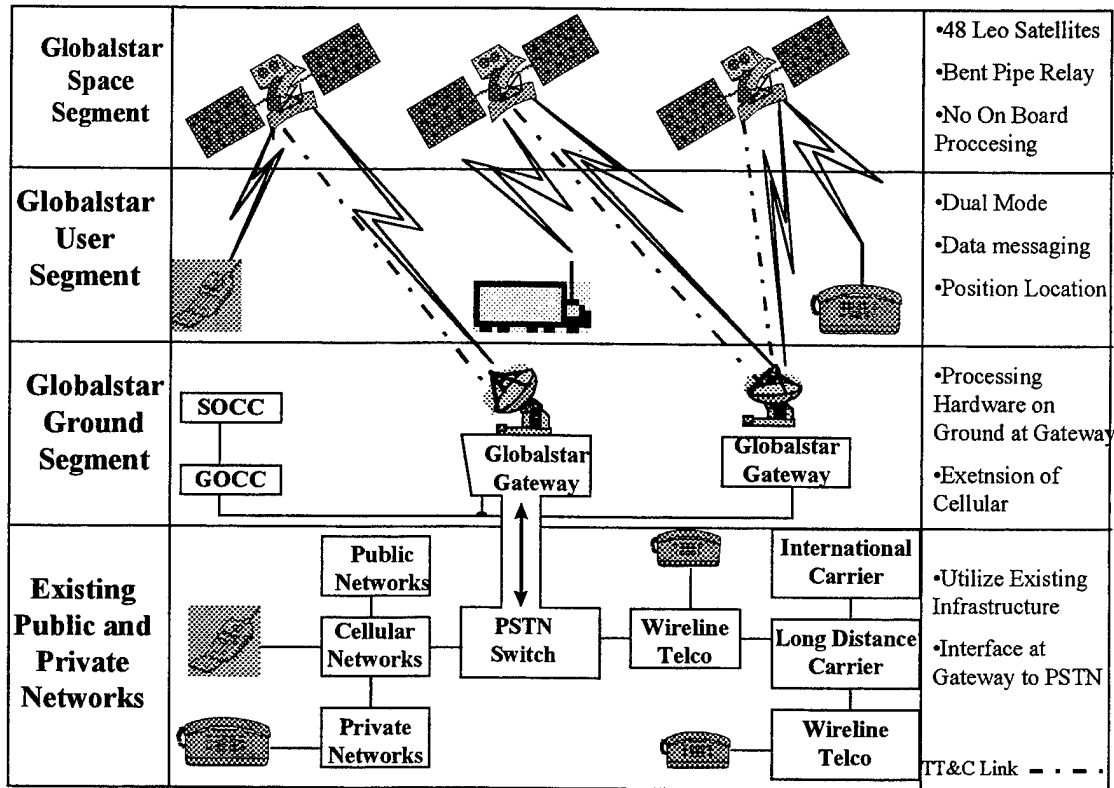

Figure 3-18. Globalstar System Architecture. After Ref. [27].

a. Space Segment

The Globalstar satellite is a simple low cost satellite. Globalstar contain no onboard processing or crosslink technology instead they use bent pipe relays. Bent pipe relay communications connect a user and a gateway. The party being called will be connected with the Gateway through the Public Switch Telephone Network or back through a satellite if the party is another Globalstar user in the same geographic area. The satellite is there axis stabilized and uses GPS to keep track of its orbital location and attitude as well as sun, earth and magnetic sensors. Momentum wheels and magnetic torquers are used for attitude control. Five hydrazine thrusters are used for orbit raising ,

station-keeping and attitude control. Electrical power is provided by two sun tracking solar arrays and batteries which provide power during eclipse periods. Communications is provided by phased array antennas. There are C-band antennas for communications with gateways, and L- and S-Band antennas for communications with user terminals. These antennas produce a pattern of 16 spot beams on the Earth's surface covering a footprint of several thousand kilometers in diameter. Figure 3-19 provides additional information on the satellites structure.

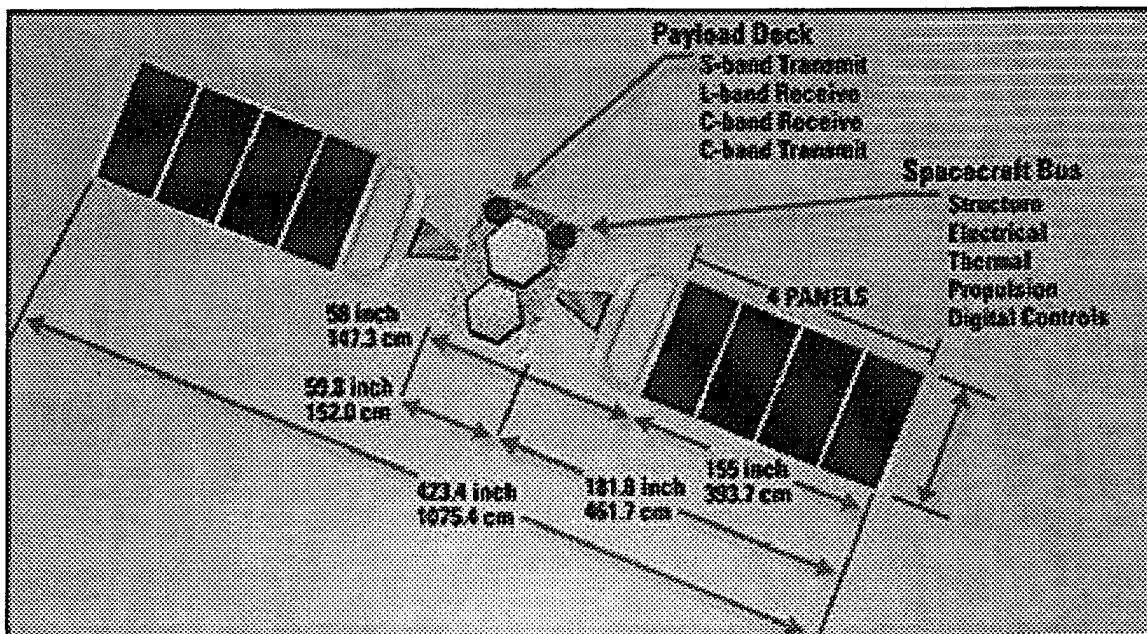

Figure 3-19. Globalstar Satellite Architecture. From Ref. [28].

The space segment is composed of 56 Globalstar satellites, 48 of which will be operational. The satellites are organized in a 48/8/1 Walker constellation (eight planes with six satellites per plane), with a 1414 km altitude and 52 degrees inclination. The orbital period is 114 minutes. The walker constellation simplifies orbital control and

concentrates the satellite density over the more highly populated temperate zones. The altitude was chosen to be below the Van Allen Belt, above the "debris" belt, low enough to minimize space loss and transit delay, and high enough to permit broad (5760 km) beam coverage. the orbital inclination was chosen to provide 100% coverage by at least two satellites from 70°N to 70°S. Figure 3-20 depicts the satellite orbital paths above the earth while Figure 3-21 illustrates the coverage provided by Globalstar. [Ref. 27: pp. 4]

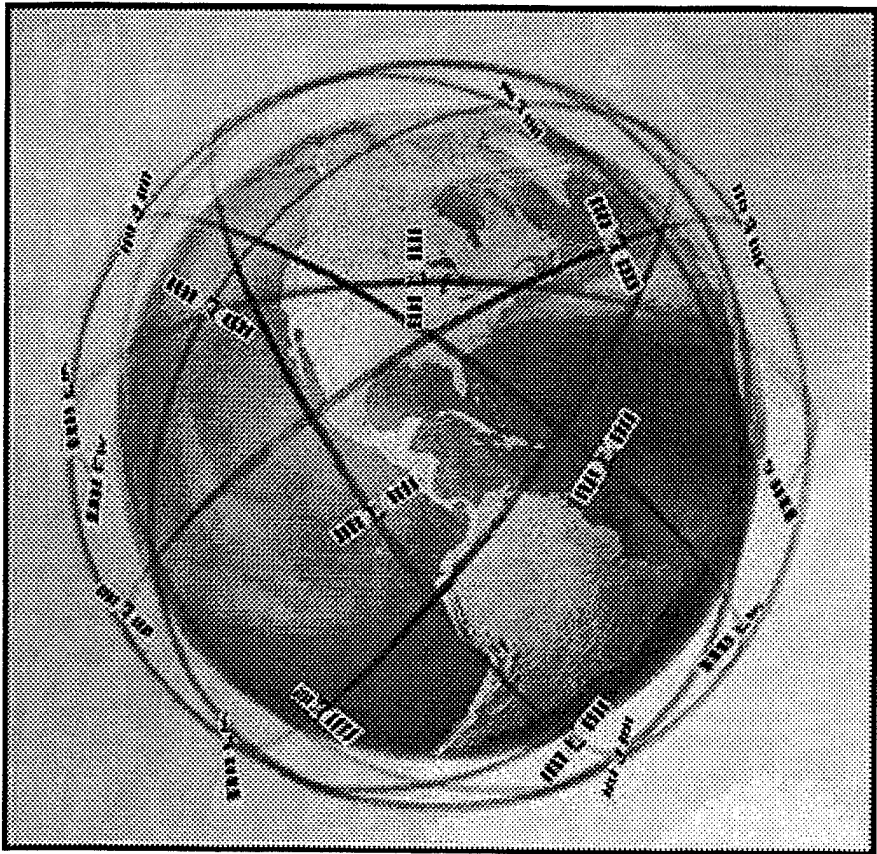

Figure 3-20. Globalstar's Satellite Orbital Paths. From Ref. [28].

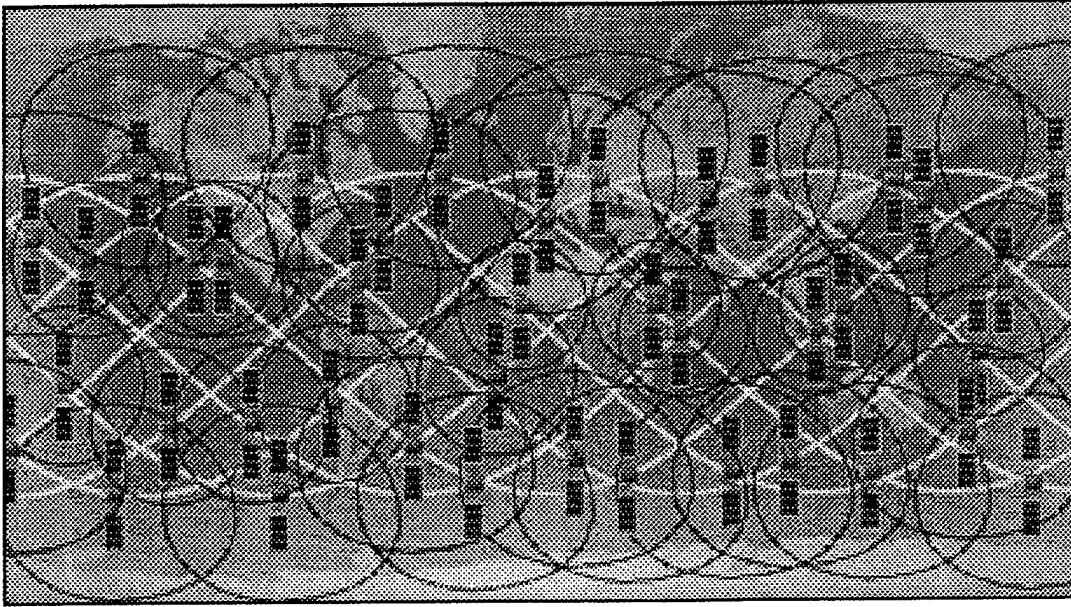

Figure 3-21. Globalstar's Satellite Coverage. From Ref. [28].

Globalstar's receives user signals at L-Band (1610-1626.5 MHz). It amplifies the signal, converts it to C-Band (6875-7055 MHz) and relays it to a gateway. This is called the reverse link. The signal from the gateway is also in C-band (5091-5250 MHz) is received by the satellite, amplified, converted to S-Band (2483.5-2500) and transmitted to the user. This is called the forward link. The allocated bandwidth is divided into thirteen 1.25 MHz channels. The L- and S- band antennas use a sophisticated phased array design to divide the user coverage into 16 beams that collectively fill the 5760 km diameter circle on the earth visible to an individual satellite. The beams, for the S-Link, form a honeycomb pattern with one beam in the center surrounded by a circle of six beams, which are in turn surrounded by a circle of nine beams. For the L-link, one beam is in the center with the remaining 15 surrounding the one. The multibeam antenna design serves two critical functions, First the individual beams provide high gain than a

single antenna spanning the entire coverage area. Second, the entire L- and S-Band frequency band allocated to Globalstar is used in each of the 16 beams (CDMA enables), which increases system capacity. The Gateway links, in C-band operate through satellite antennas that use a single beam to cover the 5760 km satellite coverage footprint. The frequency spectrum from each of the beams is combined using FDMA into a single broad spectrum. Figure 3-22 delineates Globalstar's frequency plan. [Ref. 27: pp. 7-8]

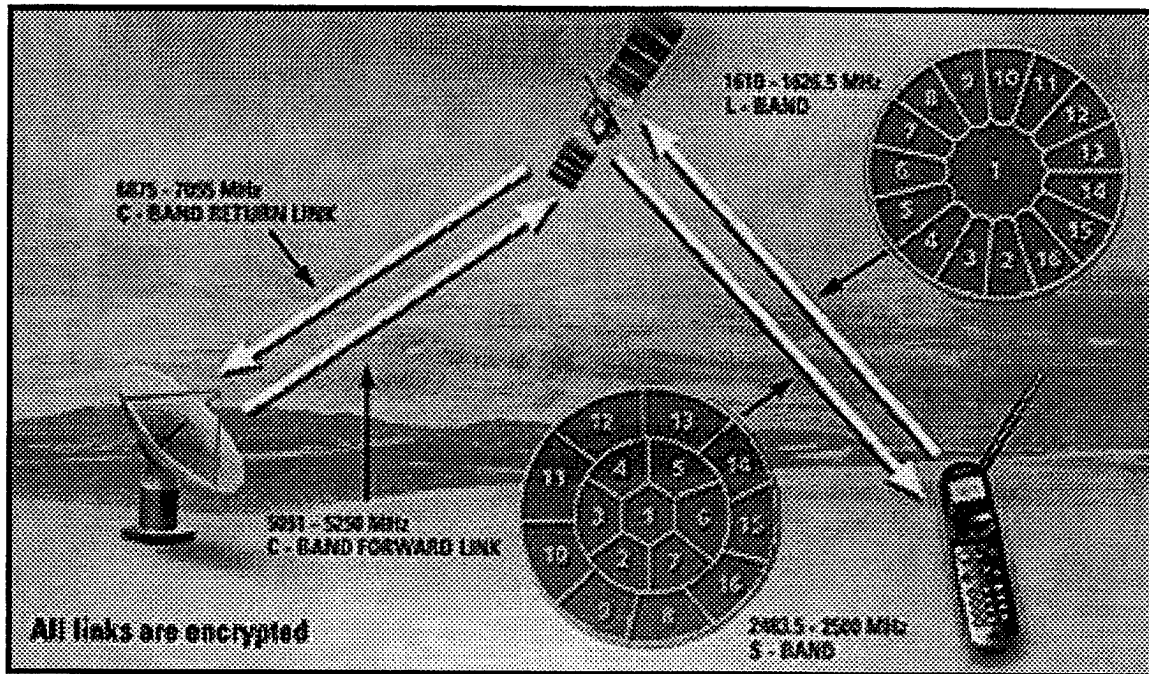

Figure 3-22. Globalstar's Frequency Plan. From Ref. [28].

b. Ground Segment

The ground segment consists of system control segment, gateway segment and user segment. The system control segment is composed of the Ground Operations Control Centers (GOCC), the Satellite Operations Control Center (SOCC) and the Globalstar Data Network. The GOCCs are responsible for planning and controlling

satellite utilization by gateway terminals, and for coordinating this utilization with SOCC. GOCCs plan the communications schedules for the Gateways and control the allocation of satellite resources to each Gateway. The Gateways then process real time traffic within these assigned resources. The SOCC manages the Globalstar satellite constellations, satellite launch and deployment activities. The SOCC, in conjunction with redundant SOCC facilities, tracks the satellites, controls the orbits and provides Telemetry and Command (T&C) services for the satellite constellation. Finally, the Globalstar Data network (GDN) is the connective network providing wide-area intercommunications between the Gateways, the GOCCs and the SOCCs using PSTN (Figure 3-23). [Ref. 29: pp. 1-2]

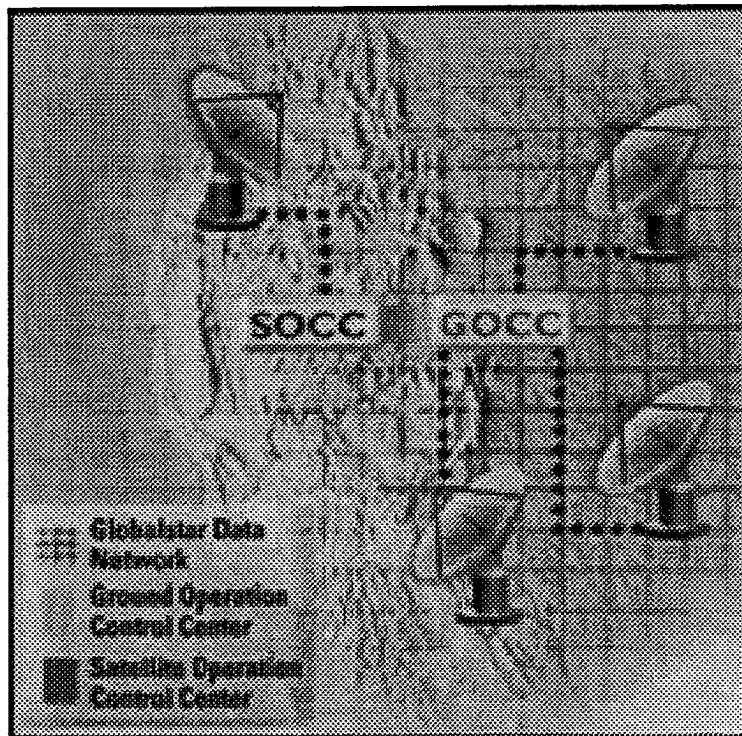

Figure 3-23. Globalstar's Data Network. From Ref. [29].

A Gateway are the interconnection point between the Globalstar satellite constellations and existing land-based telecommunications networks. A Gateway can be connected to existing PSTN and to cellular networks (GSM and AMPS). Each Gateway will contain up to four tracking antennas and radio frequency front ends that track the satellites orbiting in their view. Gateways are expected to cost from \$3 million to \$6 million, depending upon the number of subscribers being serviced by the Gateway and assuming that the Gateway will be located at the site of existing cellular or other appropriate telecommunications switch. Gateway features are listed in Table 3-13.

Gateway Features:
Standard T1/E1 interfaces to existing PSTN/PLMN
Programmable signaling interface for interconnection to local infrastructure
R1, R2 and SS7 signaling
Fire wall to ensure security between gateway sharing service providers
Seamless services for global roamers, GSM and AMPS
Cellular AMPS and GSM feature sets at all sites
Unmanned operation with remote monitoring and operations
Encryption for voice and signaling security
Diversity available for all calls

Table 3-13. Gateway Features. After Ref. [30]

Each nation with at least one Gateway within its borders will have complete control over system access by users within its territory. A single Gateway is expected to be able to provide fixed coverage over an area larger than Saudi Arabia and mobile coverage over an area almost as large as Western Europe. Thus, full global land-based coverage of virtually all inhabited areas of the globe could be theoretically achieved with as few as 100 Gateways. Figure 3-24 is an artists conception of a typical Gateway. [Ref. 26: pp. 7]

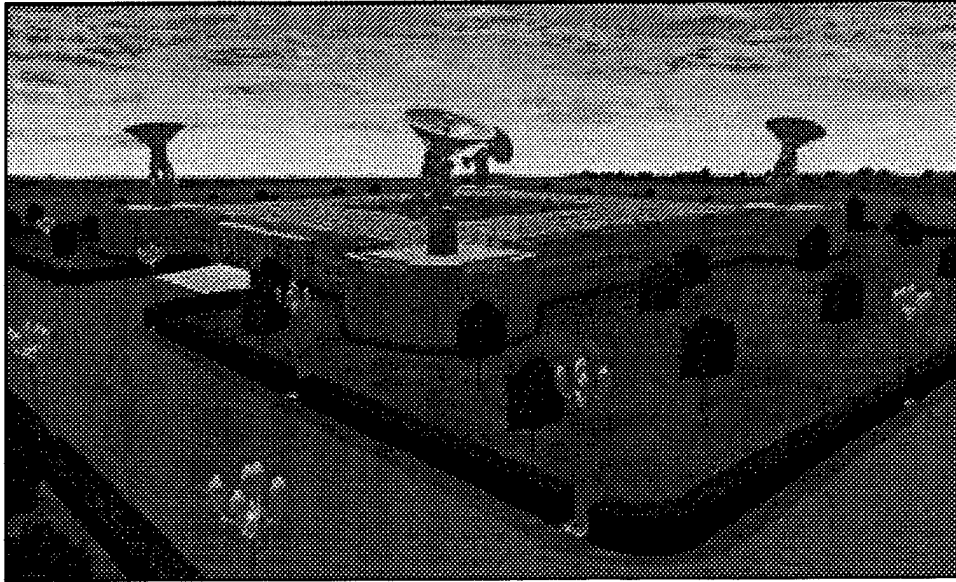

Figure 3-24. Artist Conception of a Globalstar Gateway. From Ref. [30].

The Globalstar's Subscriber Units (SU) are divided in three classes fixed, mobile and personal. The fixed SUs are phone booth type units in hard to reach areas of a country and uses a satellite tracking phased array antennae to complete the link. The mobile SUs are vehicle mounted car kits which allows the Globalstar handheld unit to be mounted in a cradle that provides power to extend life and provide hands-free operation. The personal SUs (Figure 3-25) use an omnidirectional antenna and provide worldwide digital cellular-like services and offer two global roaming options -- Dual-mode or Tri-Mode handsets. The Dual-mode SU supports Globalstar and GSM cellular standards while the Tri-Mode supports Globalstar, AMPS and IS-95 (a CDMA cellular standard). The cost associated with the use of the Globalstar system is approximately .60 cents per minute plus any charge incurred from use of PSTN or PLMN. [Ref. 31: pp. 1-2]

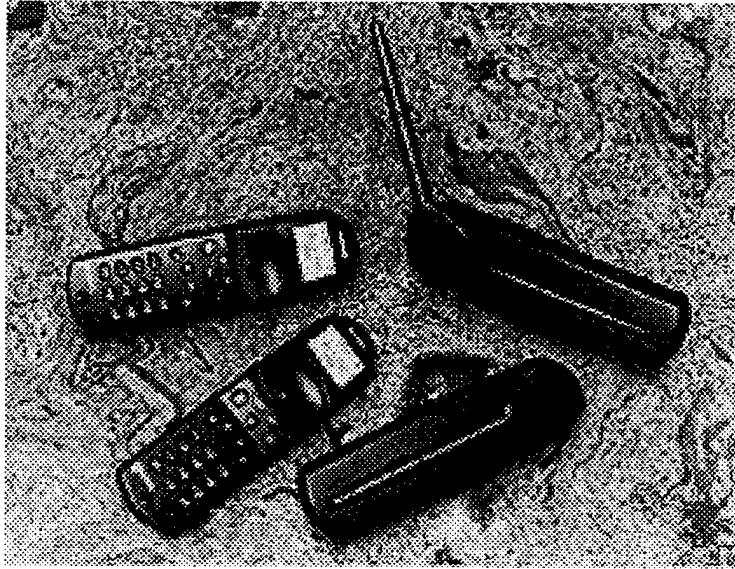

Figure 3-25. Globalstar's Personal Subscriber Units. From Ref. [31].

All three SU classes' capabilities revolve around Qualcomm's revolutionary CDMA vocoder design. Qualcomm's vocoder takes advantage of the fact that in a typical full duplex two-way voice conversation the average duty cycle of each voice is typically only 35% to 40%. With the CDMA system, the transmitted data rate is reduced when there is less speech activity allowing a corresponding reduction in transmitter power and therefore a substantial reduction in interference to others. Decrease the interference you can increase capacity by a factor of two or more and the energy efficiency by a factor of three. TDMA and FDMA can not produce these results because each signal operates in a separate time slot or frequency channel. Qualcomm's vocoder design uses a 20 msec frame interval and produces four different data rates which can vary every 20 msec frame. The terrestrial rates are 9600, 4800, 2400 and 1200 bits per second (actual data transmission is slightly lower because of overhead bits). The vocoder rate will vary each

frame in response to voice/data activity. When no activity is detected, the rate drops to 1200 bps. The CDMA system automatically reduces transmission power when lower rate vocoder frames are produced. This reduces average interference to others and allows proportionately higher capacity. [Ref. 32: pp. 14]

Globalstar's basic operations have been discussed previously and depicted in Figure 3-18 without actually discussing how Globalstar registers, authenticates and bills its users. Globalstar uses CDMA bilateration which is cooperative ranging between the SU and the Gateway. This is accomplished by a one time or sequential round-trip transmissions with an accuracy of 10 km for caller assignment and 300 m for billable services. The user position is not stored within the system. The registration and authentication procedures is described in Figure 3-26.

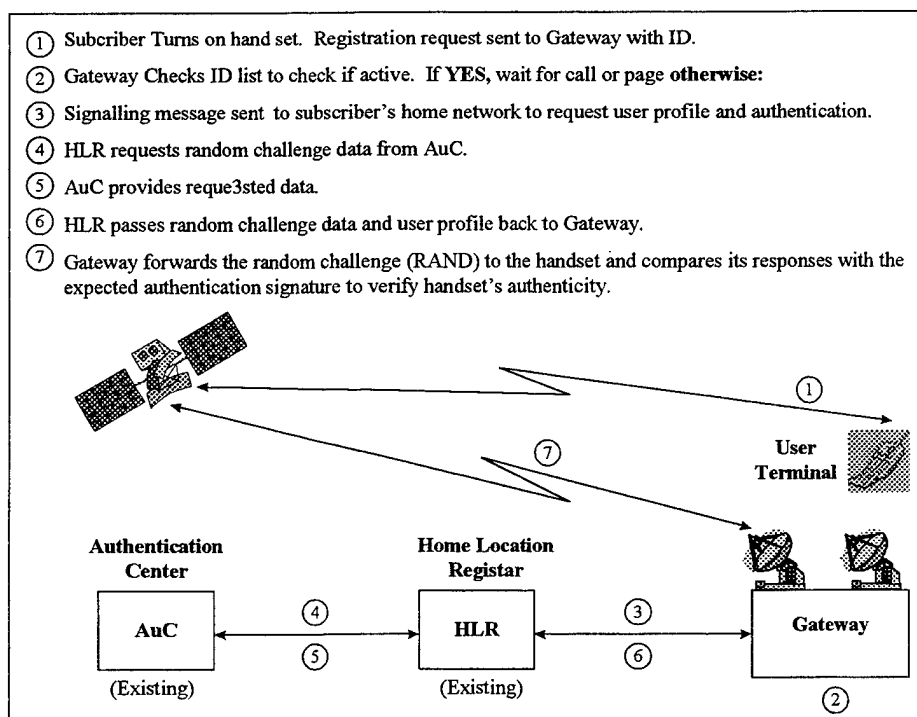

Figure 3-26. Globalstar's Registration and Authentication Procedure. After Ref. [27].

Globalstar's billing procedure is demonstrated in Figure 3-27. [Ref. 27: pp. 11-12]

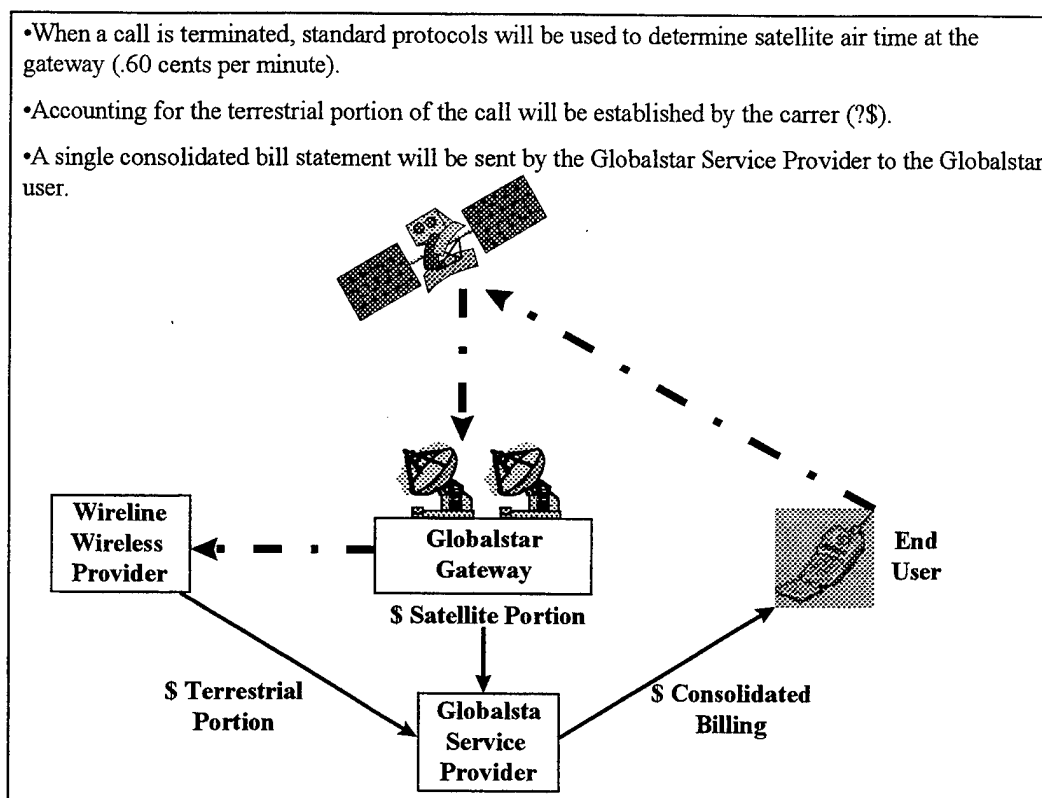

Figure 3-27. Globalstar's Billing Procedure. After Ref. [27].

2. System Strengths

Globalstar's strengths are their handsets (cost, portability, multiple modes and vocoder), CDMA signal, geolocation, proven satellite technology, path diversity and low usage costs. Globalstar's handsets are even less expensive than Iridium's handsets. Priced around \$700.00, the low cost would enable spare sets to be bought as ready replacements. The cellular phone size and weight of a Globalstar handsets provides the user with unlimited mobility allowing them to be used in most parts of the world (on land between 70°N to 70°S latitudes). The multiple mode options available with Globalstar's handsets

allow access to any terrestrial cellular phone system enhancing the systems overall flexibility. The vocoder ability to produce four different rates every 20 msec to compensate for low usage reduces transmission power which would increase battery life, produce a less detectable signal and increase overall system capacity. [Ref. 33: pp. 3-4]

CDMA, as discussed in previous sections, provides many benefits. CDMA provides spectrum-efficient, economical and high quality signals. CDMA signals are harder to detect as they use a pseudorandom number (PN) to encode the signal which is spread throughout the allotted frequency spectrum (Figure 3-6). Even when detected, the entity bent on exploitation of a CDMA signal would have to break the PN code first. Jamming a CDMA signal is also more difficult to accomplish as the CDMA signal is spread over an entire frequency channel. Finally, CDMA allows for multiple path diversity. [Ref. 33: pp. 4-5]

Geolocation, which is built into Globalstar, can provide a useful service to Navy users. The geolocation will be accurate to 300 meters for billing purposes. At that level of accuracy, the Navy could develop uses for the system such as geolocating and monitoring friendly forces. [Ref. 33: pp. 6]

Globalstar satellite technology is well proven. All the subsystems have been successfully employed on previous satellites. The bent pipe transponder system has proven to be highly reliable and efficient. Finally, the phased array antennas are electronically steerable eliminating the need for mechanical steering of antenna removes

potential mechanical failures and is much less demanding on the attitude control system.

[Ref. 27: pp. 12]

Globalstar provides path diversity by using CDMA, using a rake receiver and providing several satellites in view of one mobile terminal at one time. Globalstar provides the user the opportunity to transmit and receive by way of the satellite with the best available signal, or to (rake receiver) combine all available signals to produce an even better signal. In situations where a particular user-satellite path may be blocked by a structure or foliage, Globalstar's path diversity will provide the user access to a second or third satellite in view. This diversity scheme will achieve a high degree of circuit availability and will allow each mobile user terminal to operate at a lower power level.

Figure 3-28 demonstrates the concept of path diversity. [Ref. 33: pp. 5-6]

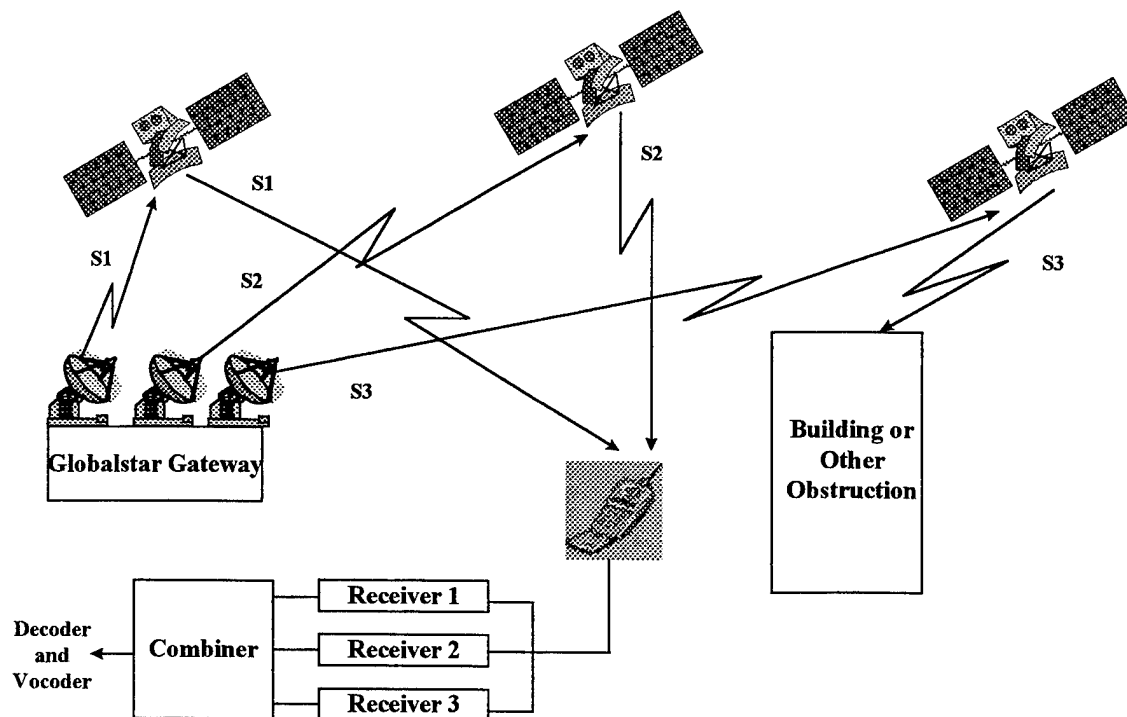

Figure 3-28. Globalstar's Path Diversity. After Ref. [27].

Globalstar's low cost of .60 cents per minute is very attractive especially when considering using Globalstar as major part of a regional network. If netted communications are possible, Globalstar looks extremely affordable. Table 3-14 presents a sample scenario for using Globalstar in a netted mode, assuming one network and varying the number of users from 2-10 for a 24 hour operation.

Number of Users	Cost/Min	Number of Hours	Total Cost
2	.6	24	\$1,728.00
4	.6	24	\$3,456.00
6	.6	24	\$5,184.00
8	.6	24	\$6,912.00
10	.6	24	\$8,640.00

Table 3-14. Example of Globalstar Costs for Netted Communications.

Even when considering that in a theater of operations you would have potentially hundreds of networks which would have to be established, the Globalstar's cost for netted communications still looks attractive. For a 30 day operation with only 100 networks, a limit of 10 per network operating 24 hours a day, a total cost of \$259,200.00. Significantly better than the \$129,600,000.00 it would cost to run the same operation with Iridium.

3. System Weaknesses

In addition to the standard commercial weaknesses shared by all commercial systems-- assured access and system vulnerabilities, Globalstar major weakness is its inability to provide truly worldwide access. The system supports a total of 130,368 full

duplex 2.4 kbps channels (channels can support up to 9.6 kbps) worldwide. Only 2716 2.4 kbps channels per satellite are available in a satellite footprint with a diameter of 5760 km. The thousands of troops in Desert Storm would have access to no more than 2716 channels which they would have to share with anyone in the Middle East with a valid Globalstar SU. [Ref. 26: pp. 5.50]

System vulnerabilities include probability of detection and interception, jamming, unencrypted data interception, exploitation of gateways and use of geolocation data by adversaries. While Globalstar's use of CDMA signals greatly reduce its susceptibility to LPD/LPI, jamming, and unencrypted data interception, CDMA alone does not eliminate these possibilities. A technologically adept adversary could detect, jam and read the unencrypted data. To detect and intercept a signal, an adversary would have to have sophisticated equipment to pick the signal out of the noise to detect it. Second, they would need to 'crack' the PN code to intercept the signal and read the unencrypted data. Third, to jam a signal, an adversary would have to either jam the entire channel or selectively jam portions of the channel in such a way as to disrupt the flow of information. [Ref. 26: pp. 5.54]

The Gateways through which the call must pass (see Figure 3-18) represent a number of potential vulnerabilities. The call must be routed to a Gateway within the same satellite footprint as a user making that call. Interception of billing information and the content of the call itself poses significant risk to Naval forces. Billing information and the call content can be exploited by an adversaries intelligence service to the detriment of

Naval operations. The geolocation data, which could also be intercepted at the local Gateway, could be used to target Naval forces. Control of any of the nodes or links of the registration and authentication process could be used by an adversary to prevent connection by a valid user by falsifying or corrupting call setup data. [Ref. 26: pp. 5.57]

Globalstar's greatest weakness is the coverage it provides. With an inclination of 52°, Globalstar can provide no (or extremely limited) polar coverage. Globalstar's coverage of the rest of the world between 70°N and 70°S latitudes is confined to areas with terrestrial gateways. In general, that limits Globalstar to land masses with limited ocean coverage (littoral areas). Globalstar has no onboard processing or crosslink capabilities. In order to use a Globalstar SU, a SU and a Gateway must be within the same satellite footprint. If there is no Gateway in the Globalstar satellite footprint of a Globalstar user, the user would have better luck communicating with smoke signals because Globalstar won't be able to provide a connection.

IV. INTEGRATION OF COMMERCIAL MOBILE SATELLITE SERVICES INTO NAVAL COMMUNICATIONS

A. MSS POTENTIAL NAVAL COMMUNICATIONS MISSIONS

Potential naval communications MSS missions considered are narrowband communications <64 kbps on the move. These missions are based on the DoD Communications FRD and discussions with DoD/USN personnel as described in preceding sections. Inmarsat provides mobile communications services, up to 64 kbps, to ships at sea while Globalstar and Iridium provide personnel communication services, at 2.4 to 4.8 kbps, to a mobile individual. The 12 Naval/DoD missions are:

- Polar Communications
- VIP/Flag Communications
- GBS Orderwire Communications
- Combat Search and Rescue Communications
- Command and Control of Tactical Forces Communications
- Maritime Operations Command Communications
- Special Operations Communications
- Naval Surface Fire Support (NSFS) Ship-to-Shore Communications
- Logistics Support Communications
- Morale Support Communications
- Peacekeeping and Humanitarian Operations Communications
- Military Support to Civilian Authorities Communications

Each mission listed above will be discussed in greater detail in the subsequent sections. A brief description will be made and the mission requirements, defined in Table 4-1, provided. The minimum and the optimum requirement will be provided. [Ref. 34: pp. F.1 - F.2]

Mission Requirement	Definition
Communications Services	Voice, Data, Fax (rates) and DISN access (Yes/No)
Area of Operation	(Latitudes which must have coverage or Global)
Platforms	(Aircraft, Ships, Submarine, Vehicular and/or Ground)
Security	Confidentiality (SI, Top Secret, Secret or None), Anti-Jam (High, Med, Low or None), LPI/LPD (High, Med, Low or None).
Operations	Service Density (High, Med or Low), Assured Access (High, Med, Low or None), Priority Calling (Yes or No)

Table 4-1. MSS Mission Requirements Defined.

1. Polar Communications

Polar Communications are those communications linking deployed forces operating between 65°N to 90°N with the DII. Examples of Polar Communications include SSN in the polar region providing status reports, medical emergency requests or Tomahawk Mission Data Update (MDU). Polar Communications mission requirements are summarized in Table 4-2. [Ref. 34: pp. F.2 - F.3]

Mission Requirements	Minimum	Optimum
Communications Services		
Voice	2400 bps	2400 bps
Data	2400 bps	2400 bps
Fax	2400 bps	2400 bps
DISN Access	No	No
Area of Operation	65°N to 90°N	65°N to 90°N
Platforms	Aircraft, Ships, Submarines, Ground	Aircraft, Ships, Submarines, Ground
Security		
Confidentiality	Secret	Top Secret
Anti-Jam	High	High
LPI/LPD	High	High
Operations		
Service Density	Low	Low
Assured Access	Med	None
Priority Calling	No	Yes

Table 4-2. Polar Communications Mission Requirements. After Ref. [34]

2. VIP/Flag Communications

The VIP/Flag Communications are those communications which provide Flag Officers and VIPs the ability to communicate effectively while on travel. An example of this mission is how CINCPAC would need to remain up to date as she travels from California to South Korea in response to escalating tensions in the area. VIP/Flag Communications mission requirements are depicted in Table 4-3. [Ref. 34: pp. F.3 - F.4].

Mission Requirements	Minimum	Optimum
Communications Services		
Voice	2400 bps (voice recognition)	4800 bps
Data	4800 bps	9600 bps
Fax	4800 bps	9600 bps
DISN Access	Yes	Yes
Area of Operation	70°N to 70°S	Global
Platforms	Aircraft, Ships, Vehicular, Ground	Aircraft, Ships, Vehicular, Ground
Security		
Confidentiality	Secret	Top Secret
Anti-Jam	High	High
LPI/LPD	None	Low
Operations		
Service Density	Low	Low
Assured Access	High	High
Priority Calling	No	Yes

Table 4-3. VIP/Flag Communications Mission Requirements. After Ref. [34]

3. GBS Orderwire Communications

The Global Broadcast Service (GBS) will provide high capacity broadcast capability to support the timely dissemination of high capacity information products worldwide (70°N to 70°S). GBS Orderwire Communications are those communications which would allow deployed forces to access the source of the information products to allow a user to tailor information requirements for delivery via GBS. An example of this mission is an artillery officer who calls back to GBS operators requesting updated battle damage assessment photos be sent via GBS broadcast. GBS Orderwire Communications mission requirements are depicted in Table 4-4. [Ref. 34: pp. F.4 - F.5]

Mission Requirements	Minimum	Optimum
Communications Services		
Voice	2400 bps	2400 bps
Data	4800 bps	4800 bps
Fax	No	No
DISN Access	No	Yes
Area of Operation	70°N to 70°S	70°N to 70°S
Platforms	Aircraft, Ships, Vehicular, Ground	Aircraft, Ships, Vehicular, Ground
Security		
Confidentiality	Secret	Top Secret
Anti-Jam	None	Low
LPI/LPD	None	Low
Operations		
Service Density	Low	Low
Assured Access	Med	High
Priority Calling	No	Yes

Table 4-4. GBS Orderwire Communications Mission Requirements. After Ref. [34]

4. Combat Search and Rescue (CSAR) Communications

DoD requirements for CSAR radio include that it provide highly accurate position information, over the horizon data communications, and line of sight voice communications. In addition, it must be a small ruggedized hand-held unit able to survive salt water immersion, aircrew ejection and support editable, canned data messages. An example of this mission is a downed pilot who edits and sends a reformatted message providing his precise status and location using integrated GPS receiver. CSAR Communications mission requirements are depicted in Table 4-5. [Ref. 34: pp. F.5 - F.6]

Mission Requirements	Minimum	Optimum
Communications Services		
Voice	2400 bps	2400 bps
Data	2400 bps	4800 bps
Fax	No	No
DISN Access	No	No
Area of Operation	70°N to 70°S	Global
Platforms	Ground	Ground
Security		
Confidentiality	None	None
Anti-Jam	High	High
LPI/LPD	High	High
Operations		
Service Density	Low	Low
Assured Access	High	High
Priority Calling	Yes	Yes

Table 4-5. CSAR Communications Mission Requirements. After Ref. [34]

5. Command and Control (C2) of Tactical Forces Communications

C2 of Tactical Forces Communications is for providing connectivity both between high level commanders and highly mobile tactical forces. This mission's main importance lies in providing a surge capacity during the initial entry into a region before standard telecommunications services can be established. For example, a Joint Task Force entry team would need voice and data services immediately to coordinate the build-up of forces in a particular area of interest. C2 of Tactical Forces Communications mission requirements are depicted in Table 4-6. [Ref. 34: pp. F.6 - F.7]

Mission Requirements	Minimum	Optimum
Communications Services		
Voice	2400 bps	4800 bps
Data	2400 bps	4800/9600 bps
Fax	2400 bps	4800/9600 bps
DISN Access	No	Yes
Area of Operation	70°N to 70°S	Global
Platforms	Aircraft, Ships, Vehicular, Ground	Aircraft, Ships, Vehicular, Ground
Security		
Confidentiality	Secret	Top Secret
Anti-Jam	High	High
LPI/LPD	Low	High
Operations		
Service Density	Low	Low
Assured Access	High	High
Priority Calling	No	Yes

Table 4-6. C2 Tactical Forces Communications Mission Requirements. After Ref. [34]

6. Maritime Operations Command Communications

Maritime Operations Command Communications require command and control connectivity between Navy ships, and shore commands. While this missions could be a subset of C2 of Tactical Forces mission, it is being considered separately due to its importance to Naval Forces. An example is direct, private connection between CINCLANT and the Captains of his ships operating off Bosnia. Maritime Operations Command Communications mission requirements are depicted in Table 4-7. [Ref. 34: pp. F.8 - F.9]

Mission Requirements	Minimum	Optimum
Communications Services		
Voice	2400 bps	4800 bps
Data	2400 bps	56 kbps*
Fax	2400	4800 bps
DISN Access	Yes	Yes
Area of Operation	70°N to 70°S	Global
Platforms	Ships, Submarines	Ships, Submarines
Security		
Confidentiality	Secret	Top Secret
Anti-Jam	High	High
LPI/LPD	None	High
Operations		
Service Density	Low	Low
Assured Access	High	High
Priority Calling	No	Yes

*Note: Requirement to Connect to the Global Command and Control System.

Table 4-7. Maritime Operations Command Communications. After Ref. [34]

7. Special Operations Communications

Special Operations Communications missions would provide for connectivity to deployed special forces units. The desire is to provide higher level commanders connectivity to their highly mobile special forces units. An example is a special forces team deployed in a foreign country calling their commander to confirm their operation is a go. Special Operations Communications mission requirements are depicted in Table 4-8.

[Ref. 34: pp. F9 - F.10]

Mission Requirements	Minimum	Optimum
Communications Services		
Voice	2400 bps	4800 bps
Data	2400 bps	4800/9600 bps
Fax	2400	4800/9600 bps
DISN Access	No	Yes
Area of Operation	70°N to 70°S	Global
Platforms	Aircraft, Ships, Ground, Vehicular	Aircraft, Ships, Ground, Vehicular
Security		
Confidentiality	Top Secret	SI
Anti-Jam	High	High
LPI/LPD	High	High
Operations		
Service Density	Low	Low
Assured Access	High	High
Priority Calling	No	Yes

Table 4-8. Special Operations Communications. After Ref. [34]

8. Naval Surface Fire Support (NSFS) Ship-to-Shore Communications

NSFS Ship-to-Shore Communications missions would provide for connectivity between NSFS systems aboard ship and ashore forward observers (FO) and fire support coordination centers. For example, a Marine FO providing firing direction to a Navy ship who is providing direct support to a Marine unit ashore. NSFS Ship-to-Shore Communications mission requirements are depicted in Table 4-9. [Ref. 34: pp. F10 - F.11]

Mission Requirements	Minimum	Optimum
Communications Services		
Voice	2400 bps	2400 bps
Data	4800 bps	9600 bps
Fax	No	No
DISN Access	No	Yes
Area of Operation	70°N to 70°S	Global
Platforms	Ships, Ground, Vehicular	Ships, Ground, Vehicular
Security		
Confidentiality	None	Secret
Anti-Jam	High	High
LPI/LPD	Low	High
Operations		
Service Density	High	High
Assured Access	High	High
Priority Calling	No	Yes

Table 4-9. NSFS Ship-to-Shore Communications. After Ref. [34]

9. Logistics Support Communications

Logistics Support Communications missions provide connectivity between logistics commands and the logistics personnel of deployed forces and perhaps an automated cargo tracking system. This service would provide for transfer of logistics reports, tracking of items in transit, manual transfers and maintenance information transfer. An example might be a forward deployed unit running low on ammunition could query a U.S. based logistics command for status of next shipment. Logistics Support Communications mission requirements are depicted in Table 4-10. [Ref. 34: pp. F11 - F.12]

Mission Requirements	Minimum	Optimum
Communications Services		
Voice	2400 bps	4800 bps
Data	2400 bps	4800/9600 bps
Fax	No	Yes
DISN Access	No	Yes
Area of Operation	70°N to 70°S	Global
Platforms	Ships, Ground, Vehicular	Ships, Ground, Vehicular
Security		
Confidentiality	None	Secret
Anti-Jam	None	Low
LPI/LPD	None	Low
Operations		
Service Density	Low	Low
Assured Access	Med	High
Priority Calling	No	No

Table 4-10. Logistics Support Communications. After Ref. [34]

10. **Morale Support Communications**

Morale Support Communications missions allow PSTN calls through the DISN from remote locations around the world. This mission allows remotely located personnel to phone home thereby enhancing unit morale. The capability would be provided by the unit with the unit personnel calling home at their own expense. For example, personnel stationed upon a FFG in the middle of the Pacific could place calls home to family members. Morale Support Communications mission requirements are depicted in Table 4-11. [Ref. 34: pp. F12 - F.13]

Mission Requirements	Minimum	Optimum
Communications Services		
Voice	2400 bps	4800 bps
Data	2400 bps	4800 bps
Fax	2400 bps	4800 bps
DISN Access	Yes	Yes
Area of Operation	70°N to 70°S	Global
Platforms	Ships, Ground	Ships, Ground
Security		
Confidentiality	None	None
Anti-Jam	None	None
LPI/LPD	None	Low
Operations		
Service Density	Low	Low
Assured Access	Low	Low
Priority Calling	No	No

Table 4-11. Morale Support Communications. After Ref. [34]

11. Peace Keeping and Humanitarian Operations Communications

Peace Keeping and Humanitarian Operations Communications mission requires connectivity of national and international tactical forces deployed in support of peacekeeping or humanitarian missions. For example, UN forces operating in Bosnia separated by mountains which prevent LOS communications. Peace Keeping and Humanitarian Operations Communications mission requirements are depicted in Table 4-12. [Ref. 34: pp. F13 - F.14]

Mission Requirements	Minimum	Optimum
Communications Services		
Voice	2400 bps	4800 bps
Data	2400 bps	4800 bps
Fax	2400 bps	4800 bps
DISN Access	Yes	Yes
Area of Operation	70°N to 70°S	70°N to 70°S
Platforms	Aircraft, Ships, Ground, Vehicular	Aircraft, Ships, Ground, Vehicular
Security		
Confidentiality	Secret	Secret
Anti-Jam	Low	Low
LPI/LPD	None	Low
Operations		
Service Density	Low	High
Assured Access	High	High
Priority Calling	No	Yes

Table 4-12. Peace Keeping and Humanitarian Operations. After Ref. [34]

12. Military Support to Civilian Authorities Communications

Military Support to Civilian Authorities Communications mission requires connectivity between the military forces and civilian authorities such as FEMA, FBI, Coast Guard or DEA. An example is the coordination necessary between the Navy, Coast Guard and DEA agents in the apprehension of a drug runner on the high seas Military Support to Civilian Authorities Communications mission requirements are depicted in Table 4-13. [Ref. 34: pp. F13 - F.14]

Mission Requirements	Minimum	Optimum
Communications Services		
Voice	2400 bps	4800 bps
Data	4800 bps	9600 bps
Fax	4800 bps	9600 bps
DISN Access	Yes	Yes
Area of Operation	70°N to 70°S	70°N to 70°S
Platforms	Aircraft, Ships, Ground, Vehicular	Aircraft, Ships, Ground, Vehicular
Security		
Confidentiality	None	Secret
Anti-Jam	Low	Low
LPI/LPD	None	High
Operations		
Service Density	Low	High
Assured Access	High	High
Priority Calling	Yes	Yes

Table 4-13. Military Support to Civilian Authorities. After Ref. [34]

B. POTENTIAL DOD ENHANCEMENTS TO COMMERCIAL MOBILE SATELLITE SERVICES

1. Inmarsat

DoD enhancements to Inmarsat include using existing encryption devices, leasing transponders and centralizing control. The Navy is currently using STU III encryption devices for 9.6 kbps communications and KG-84's for up to 64 kbps data rate encryption. Communications terminals which utilize these encryption devices are approved by the National Security Agency (NSA) to transmit Top Secret SI level communications. They all but assure that, when used properly, these devices will render the communications unreadable even to the most sophisticated adversary.

Leasing Inmarsat satellite transponders will cost the Navy less and increase Navy control. The Navy spent over \$3,000,000.00 dollars in 1995 on Inmarsat calls with only 125 ships with Inmarsat capability. The Navy will have 250 ships Inmarsat capable by the end of 1997 and will be relying even more on Inmarsat communications capabilities. For the same cost in 1995 the Navy could have leased transponders on each of the Inmarsat satellites worldwide. A leased transponder would enable the Navy to provide assured access, prioritize calls and control costs. No high priority caller would have to get a busy signal from an overtaxed satellite. The Navy could prioritize its users and bump who they needed to make room for the higher priority. The bumped individual could wait for access to the Navy's transponder or choose to use the pay-as-you-go standard Inmarsat service.

[Ref. 35]

Centralized control of Navy Inmarsat services would allow for greater flexibility and cost savings. Statistics could be compiled which would provide a basis for studying usage patterns and lead to increasing Inmarsat's utility to the Navy. A central Naval control would facilitate Navy wide broadcasts, setting up connections with other DoD agencies and provide a single connection point for GCCS. Netted communications would be possible as the Navy would own the transponder and with centralized control could set up communications nets with a portion of each transponders allotted bandwidth. A cost savings would be had by reducing the overhead that is necessary to maintain a more decentralized control system. Additionally, centralized billing, as opposed to each unit

paying for Inmarsat services, would decrease COMSAT's administrative costs which would be reflected as lower service charges to the Navy. [Ref. 35]

The enhancements discussed above along with an increase in operational diligence greatly increase Inmarsat's utility to the Navy. Table 4-14 compares Inmarsat with the DoD-enhanced Inmarsat using the required capabilities identified by the MUS WIPT discussed earlier.

Required Capabilities	Inmarsat	DoD-enhanced Inmarsat
Assured Access	Red	Grn
Netted Comms	Red	Grn
Comms On the Move	Ylw	Ylw
Joint Interoperable	Ylw	Ylw
World Wide Coverage	Grn	Grn
Point to Point Comms	Grn	Grn
Broadcast	Grn	Grn
Polar	Red	Red

Table 4-14. Inmarsat versus DoD-enhanced Inmarsat. After Ref. [7]

2. Iridium

DoD potential enhancements to Iridium include a secret key system, NSA developed STU III encryption capability, specializing terminals, a single government owned and operated gateway and contracting additional services. Iridium has incorporated features to prevent fraudulent use of the system like "cloning a cellular phone". To accomplish this, the users unique number is never transmitted. The user is assigned a new temporary ID to use on at least a daily basis. The phone number of the user does not change. The gateway stores the temporary ID for each user. An

authentication process using a secret key and cryptographic algorithm is performed prior to the call set up. The secret key is virtually impossible to break as the algorithm uses a 64 bit random challenge, 32 bit signed response and finally, a 128 bit secret key. [Ref. 36: pp. 13 14]

Condor is a NSA sponsored program intent on providing modular security to mobile phones including mobile satellite service phones. Condor will provide a sleeve which will attach to the back of Iridium's cellular handset with the battery attaching to the back of the sleeve. The sleeve will accommodate a cryptographic PCMCIA card which will provide STU-III capable communications. When connected to the Iridium handset, Condor will create a trusted handset capable of communicating securely anywhere in the world. [Ref. 37]

The terminals provided by Iridium will fit most missions. However, ruggedized terminals will have to be developed for shipboard use and field use. Shipboard use, to include CSAR missions, will require ruggedized and specialized terminals. To operate in a ship environment, the terminals will have to be able to be salt water resistant. To be of use for CSAR mission, the terminals will have to be salt water proof and shock resistant. Similar requirements will be necessary for operating under the physically stressful environment of military operations ashore. Shore terminals will have to be weather and shock resistance. Finally, GPS like capabilities can be incorporated into certain terminals such as remote sensor terminals and CSAR terminals to assist in providing position

location data. DoD has extensive experience in ruggedizing and specializing commercial equipment to meet its own unique needs making these requirements imminently attainable.

A single government owned and operated gateway greatly increases Iridium's utility for Navy and DoD operations. As discussed in Chapter Three, a commercial Iridium call's information passes through numerous foreign gateways which pose significant security risks to DoD users. By using a government gateway, foreign involvement in a DoD call can be eliminated. The government gateway would function as the home, visiting and distribution gateway. No foreign government need ever see DoD access requests, signaling information or billing information. Government users must use the government gateway which will provide a number of additional utilities. Control of DoD caller access and priority schemes can be established. DoD callers could be prioritized according to the needs and desires of the regional commander and the government gateway managers would be able to implement that plan among the callers under their control. Pseudo netted communications could be enabled by combining calls at the gateway in a way similar to conference calling. Direct interface into the DISN along with the ability to originate calls from the gateway to an Iridium user will increase Iridium's Joint Interoperable capabilities. Finally, consolidation in billing will significantly reduce costs. [Ref. 38]

Additional services which can be contracted from Iridium are priority preference, guaranteed call access and a surge provision. The government gateway can only prioritize DoD calls. Furthermore, the gateway can only provide assured access among DoD users;

meaning they cannot remove callers other than DoD callers to make room for a higher priority caller. If a satellite is busy, subsequent calls made to said satellite are queued in a first come first serve basis. DoD could pay for the privilege of going to the top of the queue when a satellite is busy and obtaining the next available circuit. DoD could also pay for a number of circuits on each satellite to be reserved exclusively for DoD use. For example, a satellite over a particular hot spot is overwhelmed by commercial users, but with the guaranteed access clause, DoD would still have a number of circuits available for its exclusive use. Finally, CNN and other commercial information entities pay communications satellite companies a contingency fee for the privilege of being able to up their demand upon a moments notice. DoD could work out similar terms. DoD could pay a contingency fee for the ability to increase the number of guaranteed circuits over a particular hot spot during a crisis. This ability would increase DoD's surge capacity and greatly increase Iridium's utility during times of crisis.

The enhancements discussed above in conjunction with Iridium's truly world wide coverage would greatly increase Iridium's utility to the Navy. Table 4-15 compares Iridium with the DoD-enhanced Iridium using the required capabilities identified by the MUS WIPT discussed earlier.

Required Capabilities	Iridium	DoD-enhanced Iridium
Assured Access	Red	Grn
Netted Comms	Red	Ylw
Comms On the Move	Grn	Grn
Joint Interoperable	Ylw	Grn
World Wide Coverage	Grn	Grn
Point to Point Comms	Grn	Grn
Broadcast	Ylw	Ylw
Polar	Grn	Grn

Table 4-15. Iridium versus DoD-enhanced Iridium. After Ref. [7]

3. Globalstar

DoD potential enhancements to Globalstar include a NSA developed STU III encryption capability, specialized terminals, government worldwide fixed and transportable gateways, group services and contracting additional services. Condor is a NSA sponsored program intent on providing modular security to mobile phones including mobile satellite service phones. Condor will provide a sleeve which will attach to the back of Globalstar's cellular handset with the battery attaching to the back of the sleeve. The sleeve will accommodate a cryptographic PCMCIA card which will provide STU-III capable communications. When connected to the Globalstar handset, Condor will create a trusted handset capable of communicating securely anywhere in the world. [Ref. 37]

The terminals provided by Globalstar will fit most missions. However, ruggedized terminals will have to be developed for shipboard use and field use. Shipboard use, to include CSAR missions, will require ruggedized and specialized terminals. To operate in a ship environment, the terminals will have to be able to be salt water resistant. To be of

use for CSAR mission, the terminals will have to be salt water proof and shock resistant. Similar requirements will be necessary for operating under the physically stressful environment of military operations ashore. Shore terminals will have to be weather and shock resistance. Finally, GPS like capabilities can be incorporated into certain terminals such as remote sensor terminals and CSAR terminals to assist in providing position location data. DoD has extensive experience in ruggedizing and specializing commercial equipment to meet its own unique needs making these requirements imminently attainable.

Globalstar's shortcomings in regard to world wide coverage and foreign gateway interaction with DoD calls was discussed in Chapter III. One proposal to greatly increase world wide coverage while decreasing dependence on foreign gateways for DoD calls is a combination of fixed and transportable DoD gateways. The fixed gateways would be placed strategically around the world to minimize coverage gaps specifically over the open ocean and higher latitudes. Transportable DoD gateways could be flown into any AOR to establish a DoD only gateway eliminating the need to use a foreign gateway during a sensitive operation. Control of these gateways provide many of the same benefits mentioned above in the section on Iridium -- control of DoD caller access, information, establishing priority schemes and increasing joint interoperability. [Ref. 39]

Group services, which can be provided by Globalstar, will enable broadcast and networking capabilities. Work group services work on a defined group of services and provide for one talker with many listeners. The system allocates broadcast channels dynamically based on the users. A single phone number activates the service which can

operate within the Globalstar system or a terrestrial system. Group services are five to twenty times more efficient than normal telephone conferencing. Services provided are voice, data, multiple work groups, text messaging, voice mail and security. Features include push-to-talk ,for netted communications on demand, selection of security modes, and system notifications on who's talking, workgroups active, conventional calls, voice mail availability, text messaging and paging/alerting functions. [Ref. 40]

Additional services which can be contracted from Globalstar are priority preference, guaranteed call access and a surge provision. A government gateway can only prioritize DoD calls. Furthermore, a gateway can only provide assured access among DoD users. Meaning they cannot remove callers other than DoD callers to make room for a higher priority caller. If a satellite is busy, subsequent calls made to said satellite are queued in a first come first serve basis. DoD could pay for the privilege of going to the top of the queue when a satellite is busy and obtaining the next available circuit. DoD could also pay for a number of circuits on each satellite to be exclusively reserved for DoD use. For example, a satellite over a particular hot spot is overwhelmed by commercial users, but with the guaranteed access clause, DoD would still have a number of circuits available for its exclusive use. Finally, CNN and other commercial information entities pay communications satellite companies a contingency fee for the privilege of being able to up their demand upon a moments notice. DoD could work out similar terms. DoD could pay a contingency fee for the ability to increase the number of guaranteed circuits

over a particular hot spot during a crisis. This ability would increase DoD's surge capacity and greatly increase Globalstar's utility during times of crisis.

DoD-enhanced Globalstar MSS would have significant impact on the manner in which Naval forces communicate. Table 4-16 compares Globalstar with the DoD-enhanced Globalstar using the required capabilities identified by the MUS WIPT discussed earlier.

Required Capabilities	Globalstar	DoD-enhanced Globalstar
Assured Access	Ylw	Ylw/Grn
Netted Comms	Ylw	Grn
Comms On the Move	Grn	Grn
Joint Interoperable	Ylw	Grn
World wide Coverage	Ylw	Ylw/Grn
Point to Point Comms	Grn	Grn
Broadcast	Ylw	Grn
Polar	Red	Ylw

Table 4-16. Globalstar versus DoD-enhanced Globalstar. After Ref. [7]

C. DOD UHF SYSTEMS AND DOD-ENHANCED MSS ABILITY TO SATISFY DOD/NAVAL REQUIREMENTS

DoD UHF systems and DoD-enhanced Mobile Satellite Services (MSS) can be compared against the DoD functional requirements which were discussed in Chapter II.

These functional requirements are delineated below:

- **Connectivity** - The geographical **coverage** of the satellite communications system in reference to the users of that system and the **capacity** of the system relative to data throughput.
- **Protection** - The ability to avoid, prevent, negate, or mitigate the degradation, disruption, denial, unauthorized access, or exploitation of communications services by adversaries or the environment.

- **Access and control** - Access means immediate accessibility and availability when needed. Control refers to the ability to effectively plan, operate, manage and manipulate the available SATCOM resources.
- **Interoperability**- The ability of varying forces to communicate with one another quickly and effectively.
- **Flexibility** - The ability to support the full dynamic range of military operations and missions.
- **Quality of Service** - The ability to transfer information in a timely and accurate manner.

DoD UHF systems underachieve in the areas of geographical coverage (limited to 65° N to 65° S latitudes), capacity (210 unfulfilled requirements described in Table 2-10), protection (has all of UHF vulnerabilities), interoperability (specialized service unique terminals), flexibility (inability to support omnidirectional antennas limit utility man mobile communications) and quality of service (over taxed systems impact adversely on quality).

DoD UHF systems provide much greater access and control as the systems are completely under DoD control. DoD-enhanced MSS (Inmarsat, Iridium, and Globalstar), on the other hand, provide marginal access and control as only a portion of the system and certain user segments are under direct DoD control. Protection is another problem area for DoD-enhanced systems. Although the communications can be secured using encryption devices, UHF communications are inherently vulnerable to a skilled adversary. Furthermore, the civil ownership of these systems increase the possibility of security problems. DoD-enhanced MSS taken together do satisfy many of DoD/Naval functional requirements. DoD-enhanced MSS provide greater coverage (with Iridium's worldwide coverage), capacity (thousands of circuits versus hundreds for DoD UHF systems), interoperability (with DoD owned gateways and connection into DISN), flexibility

(operational doctrine could be developed to cover full range of military operations and missions) and finally, quality of service (MSS will push for ever higher quality of service to support commercial interests as well as DoD). Table 4-17 uses a red (no satisfaction), yellow (partial satisfaction) and green (full satisfaction) to compare DoD UHF systems versus DoD-enhanced MSS.

DoD/Naval Functional Requirements	DoD UHF Systems	DoD-Enhanced MSS
Connectivity	Red/Yellow	Yellow/Green
Protection	Yellow	Yellow
Access and Control	Green	Yellow
Interoperability	Red/Yellow	Yellow/Green
Flexibility	Yellow	Yellow/Green
Quality of Service	Red/Yellow	Yellow/Green

Table 4-17. DoD UHF Systems Versus DoD-Enhanced MSS in Satisfying DoD/Naval Functional Requirements.

D. INTEGRATION OF INMARSAT INTO NAVAL COMMUNICATIONS

Inmarsat is already well on its way to being completely integrated into Naval Communications. As discussed in Chapter III, Inmarsat will be installed on every Naval combatant afloat by the end on 1998. Due to its fixed-to-the-ship nature and inherent vulnerabilities, Inmarsat main utility to Naval Communications will be in open water and outer littoral regions of the world. Naval communications missions for which Inmarsat is well-suited are C2 of Tactical Forces Communications, Maritime Command and Control of Tactical Forces Communications, GBS Orderwire Communications, Logistics Support Communications, Moral Support Communications, Peacekeeping and Humanitarian

Operations Communications and Military Support To Civilian Authorities
Communications. [Ref. 35]

Inmarsat is extremely well-suited for C2 of Tactical Forces Communications, Maritime Command and Control of Tactical Forces Communications on the open ocean and early entry into a region of instability. The Global Command and Control System (GCCS) and Joint Maritime Command Information System (JMCIS) are the future of both C2 and Maritime operations. Both require a relatively large two way pipe to operate effectively. Inmarsat, with a capability of up to 64 kbps, meets GCCS and JMCIS requirements which greatly increase its utility for use in C2 and Maritime Operations communications.

GBS Orderwire, Logistical Support Communications and Moral Support Communications can all be provided by Inmarsat simultaneously. By multiplexing a number of 9.6 kbps links, a ship at sea can order a large image file from a GBS broadcast provider, connect to logistical support in CONUS via a 9.6 kbps using SALTS program and still have a number of pay-as-you-use phone calls to mom, providing moral support to the troops.

Inmarsat was the first company to provide commercially available mobile communications world wide. As such, many nations, organizations, government agencies, and DoD entities purchased quite a few Inmarsat terminals. Having such a large and varied install base currently makes Inmarsat a natural for Peacekeeping and Humanitarian
Operations Communications and Military Support To Civilian Authorities

Communications. In the near term, as many as 10,000 Inmarsat terminals as small as a notebook computer have been sold world-wide, making the likelihood relatively high that all parties concerned during a Peacekeeping, Joint or Interagency action will have access to an Inmarsat terminal. Figure 4-1 depicts a number of Naval communications missions for which DoD-enhanced Inmarsat appears well-suited.

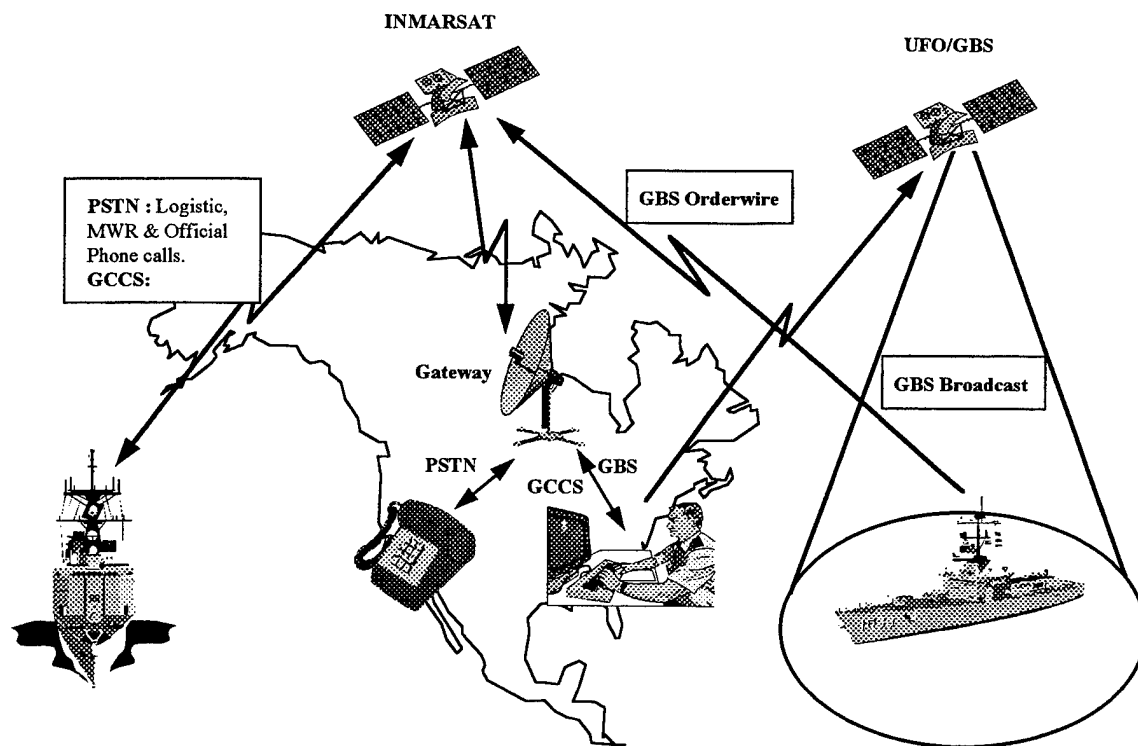

Figure 4-1. Inmarsat Naval Communications Missions.

E. INTEGRATION OF IRIDIUM INTO NAVAL COMMUNICATIONS

Iridium will be used by DoD and the Navy in some capacity. Iridium as already begun launching satellites and developing its infrastructure. DISA is actively pursuing Iridium services. A site has been chosen and work begun on a DoD Iridium gateway. NSA is producing, in cooperation with Iridium, a Condor sleeve to enable STU-III

capable handsets. Additional research is being done on netted services and contracting for additional services. With DoD enhancements and world wide capabilities, Iridium will be able to satisfy a number of Naval communications missions. Naval missions which Iridium is particularly well suited for include Polar Communications, VIP/Flag Communications, GBS Orderwire Communications, Combat Search and Rescue Communications, Special Operations Communications, Logistics Support Communications, Peacekeeping and Humanitarian Operations Communications and Military Support to Civilian Authorities Communications. [Ref. 41]

Iridium is the only MSS under discussion which can cover the polar regions. As such, Iridium can satisfy many of the polar communications requirements with some additional modification. Naval forces which are operating in the North and South pole research stations can use Iridium as is for communications which up to now have been relegated to land lines and repeater stations. To provide services to Naval strategic forces, additional research will need to be undertaken to develop LPI/LPD directional antenna which will decrease the risk of geolocation of those assets. An Iridium tracking parabolic dish or phased array antenna would significantly reduce the likelihood of detection.

VIP/Flag Communications require a worldwide capability to support VIP/Flag travel which can easily be accomplished using DoD-enhanced Iridium. With STU-III capable communications and a DoD gateway, Iridium can provide secure links for VIP/Flag travelers which would be extremely difficult for an adversary to exploit. By using Iridium for a good portion of VIP/Flag travel communication, current tasking of

tactical MILSATCOM assets could be significantly reduced freeing them for tactical forces.

GBS Orderwire could be satisfied by Iridium in all but the most strenuous operational scenarios. Given Iridium's use of TDMA/FDMA in the UHF frequency range, Iridium should not be used in a tactical environment in which Naval forces could be endangered by jamming or geolocation of their Iridium handsets. However, Naval forces operate worldwide in numerous capacities. In those situations where the forces are safe from exploitation, Iridium could be used to order broadcast data to be delivered by GBS.

Combat Search and Rescue Communications (CSAR) can be accomplished using Iridium with some additional DoD enhancements to the system. With its worldwide capabilities, Iridium can provide an extremely valuable service by providing CSAR services to the Navy's widely dispersed forces. Modifications which would enhance Iridium's utility in CSAR include contracting guaranteed circuits, ruggedizing the handset, integrating GPS and microburst communications. As discussed previously, a number of circuits could be reserved for a cost worldwide ensuring a circuit would be available for CSAR. Ruggedizing the handset would include salt waterproofing and providing shock resistance capable of withstanding aircraft ejection. GPS has been integrated into numerous applications and could be integrated into Iridium handsets to reduce Iridium's geolocation capabilities from hundreds of meters to tens of meters. Finally, using existing cellular digital messaging standards, microburst preformatted messages could be used to minimize the likelihood a CSAR communication could be located by an adversary.

Iridium cannot satisfy all of the Navy's Special Operations Communications needs due to its use of TDMA/FDMA. However, Iridium's worldwide capability combined with the DoD-controlled gateway make it an attractive communications option for startup actions or other initial covert operations. First, in an urban environment, differentiating an Iridium phone from other cell phones would be next to impossible. Second, using microburst communications, special operations Iridium communications would be difficult to geolocate. Finally, if the adversary is not expecting covert operations, short term Iridium usage would more than likely go unnoticed.

Logistics Support Communications can be satisfied by Iridium in a number of ways. The logistical software SALTS can be supported by the data rates provided by Iridium to assist logisticians in making logistical requests. Iridium could also satisfy some of the Strategic Airlift requirements by providing low data rate information to enhance coordination of aircraft routing, passenger data, crew scheduling, etc. Finally, Iridium friendly devices could send logistic shipment location data which could be used to track supplies as they transit from CONUS to their final destination.

Iridium can become a cornerstone for Peacekeeping and Humanitarian Operations Communications and Military Support to Civilian Authorities Communications. Given the DoD controlled gateway, Iridium can provide secure and reliable communications which will facilitate peacekeeping/humanitarian operations and military support to civilian authorities. Iridium handsets could be issued for these missions to provide a standard communications facility which will be inherently interoperable thereby greatly reducing the

communications planning and overhead. Figure 4-2 depicts a number of Naval communications missions which DoD-enhanced Iridium appears to be well suited.

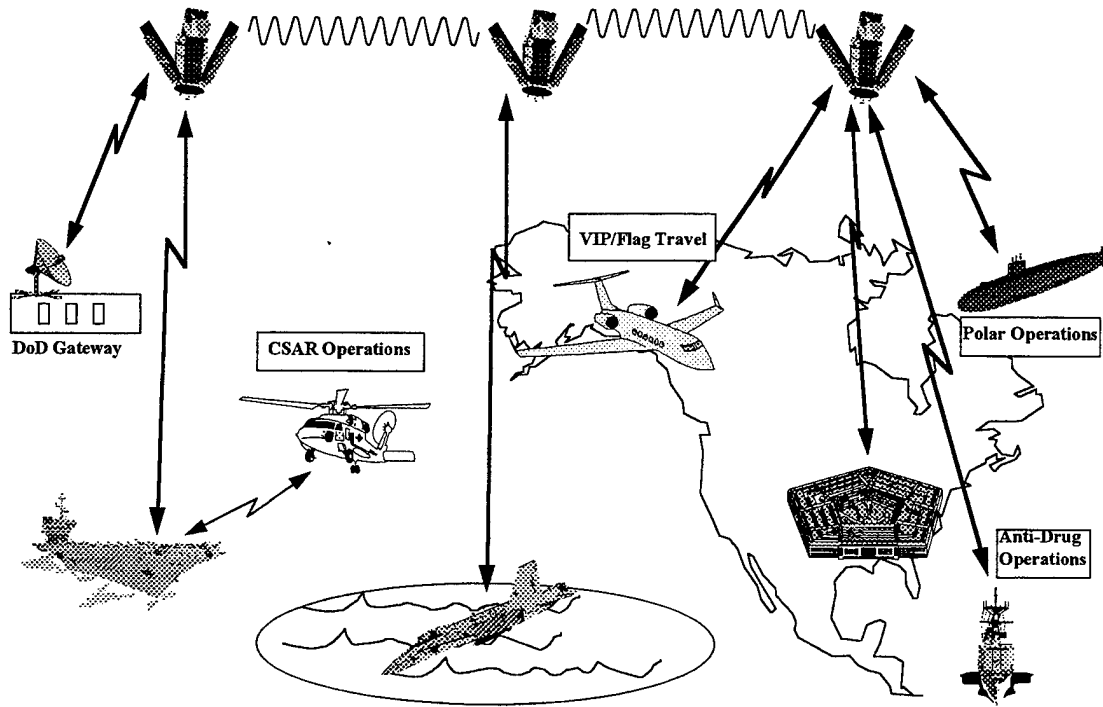

Figure 4-2. Iridium Naval Communications Missions.

F. INTEGRATION OF GLOBALSTAR INTO NAVAL COMMUNICATIONS

DoD-enhanced Globalstar possesses a number of characteristics which make it extremely attractive for use by Naval forces. While Globalstar's bent pipe characteristics and lack of worldwide coverage limit its day to day usefulness, Globalstar's use of CDMA and Group Services makes it particularly attractive for more extensive use by Naval tactical forces. CDMA communications are inherently more difficult for an adversary to exploit and Group Services allow tactical forces to operate in a networked mode. Naval communications missions which Globalstar is particularly well suited for include GBS

Orderwire, Logistics Support Communications, C2 of Tactical Forces Communications, Special Operations Communications, and NSFS Ship-to-Shore Communications. [Ref. 40]

Globalstar's CDMA communications signal would allow for GBS Orderwire and Logistics Support Communications by tactical users in the field. An adversary would be hard pressed to geolocate or interfere with these short requests by a Globalstar user for a GBS broadcast tailored for their needs. With a tactical gateway deployed in theater, a Globalstar user could request logistical assistance from the rear where the request could be taken care of or relayed to a logistical support center out of theater.

C2 Tactical Forces Communications rely on networks for situational awareness and to pass C2 information to units in the field. Globalstar's ability to provide a secure communications path combined with Group Services allow the theater commander the flexibility to establish Globalstar C2 nets as needed. In addition to networks provided by Globalstar's Group Service, Globalstar's broadcast capabilities enable commanders to push C2 information and guidance to units deployed in the field virtually eliminating the possibility of individual unit detection. Finally, units could use Globalstar friendly devices and random microburst transmissions of unit status information enhancing the tactical commanders view of the battlefield.

Special Operations Communications involving incursions deep into adversarial territory can be accomplished using Globalstar in conjunction with a Globalstar gateway deployed in theater. Globalstar's CDMA communications makes detection and geolocation difficult for all, but the most sophisticated adversary. Special operational

techniques such as microburst communications in conjunction with push broadcast decrease an adversaries ability to disrupt communications even further. Globalstar's additional ability to combine multiple signals from all satellites in view further enhance Special Forces ability to operate in a wide range of areas from a cluttered urban environment to a heavily forested region.

Naval forces using NSFS Ship-to-Shore Communications to direct Naval gun fire can rely on Globalstar. Again, CDMA greatly reduces the possibility of detection while a forward observer directs naval gun fire or calls for naval air support in support of tactical operations ashore. Furthermore, Globalstar's ability to operate on the move in a cluttered environment would allow the forward observer to communicate while remaining concealed from view. Figure 4-2 depicts a number of Naval communications missions which DoD-enhanced Globalstar appears to be well suited.

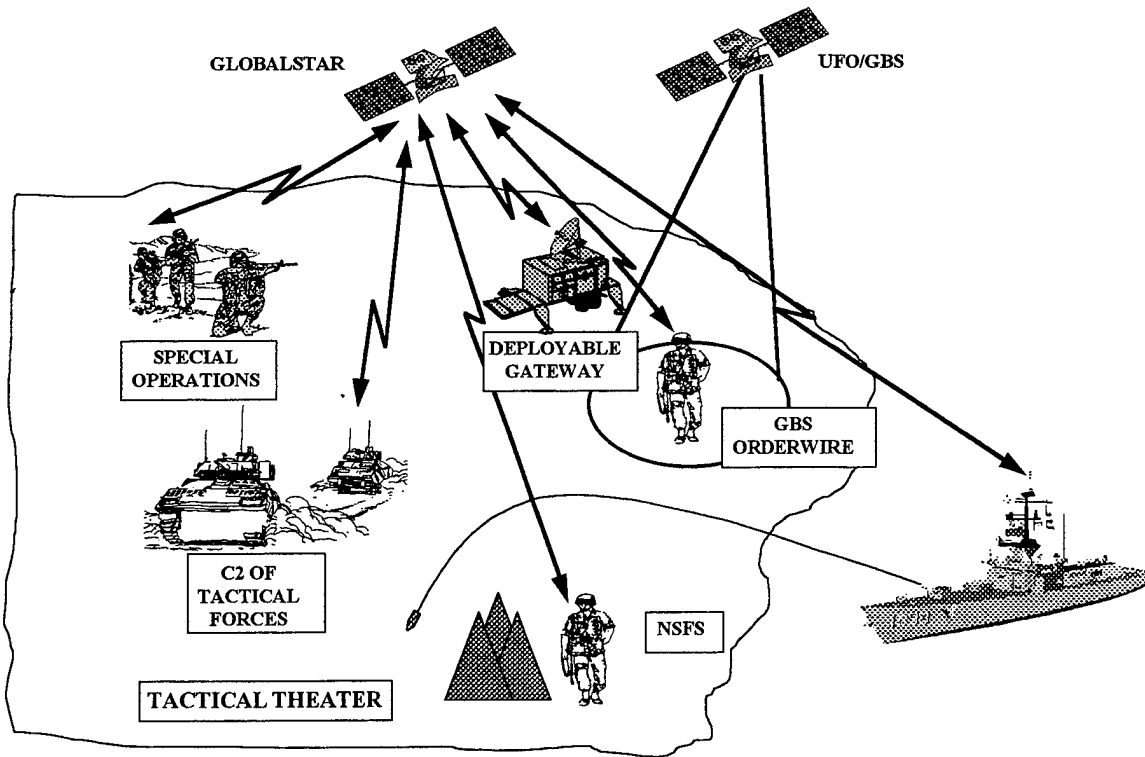

Figure 4-3. Globalstar Naval Communications Missions.

V. CONCLUSIONS AND RECOMMENDATIONS

A. CONCLUSIONS

As discussed in Appendix A, DoD Satcom Systems cannot deliver enough UHF services to support today's widely dispersed mobile forces information intensive needs. By utilizing existing and soon-to-be-realized commercial MSS capabilities, information flow to the Navy's highly mobile and dispersed forces can be greatly increased. By capitalizing on each of the DoD-enhanced MSS strengths, DoD-enhanced MSS communications can provide the missing mobile communications piece in the Naval communications puzzle for the next five to ten years. Greater military control and additional cost savings could be realized if the DoD developed a MSS-compatible in-theater tactical arena mobile communications system (TAMCS). Given the inherent vulnerabilities of commercial MSS and the cost of service, DoD should explore military MSS options which would decrease dependence on commercial systems. In the long run, whether or not DoD chooses to actively integrate commercial MSS into its communications infrastructure, DoD needs to understand the implications of adversaries who will utilize commercial MSS.

As discussed in Chapter IV, each of the MSS under discussion provide certain characteristics which make them attractive for certain missions with some mission overlap. DoD-enhanced Inmarsat provides Naval forces afloat with a larger two-way data rate capability which can be used for bandwidth-intensive functions such as BDA, GCCS, and Tomahawk MDU. Additionally, Inmarsat can support multiple, lower data-rate services

such as SALTS, multiple secure phone sessions and morale and welfare services. DoD-enhanced Iridium with its crosslinks and single DoD gateway is well-suited for missions which require world-wide connectivity. World-wide missions which could be undertaken by Iridium include certain VIP/Flag Travel, Logistic, CSAR, Polar, Peacekeeping/Humanitarian, and Military Support to Civilian Agencies communications. DoD-enhanced Globalstar with its CDMA technology, deployable DoD gateway and Group Services can provide tactical mobile communications services in-theater. In-theater missions for which DoD-enhanced Globalstar is well-suited for include GBS Orderwire, Logistics Support, C2 of Tactical Forces, Special Operations, and NSFS Ship-to-Shore communications.

The weaknesses of commercial MSS include cost of service, assured access, and vulnerability issues. As the commercial MSS mature, demand for their services by the commercial sector will increase. The military will also begin to increase usage as these systems are integrated into DoD's communications infrastructure. This increase in demand by the commercial sector will reduce the availability of circuits. It will make it more difficult and costly to contract for assured services with the various commercial MSS as DoD's usage becomes less important to the commercial MSS financially. DoD needs to investigate the development of a DoD-owned MSS to offset these trends and to maintain its mobile communications capabilities at an affordable cost and performance level.

B. RECOMMENDATIONS

Research into integrating commercial MSS into Naval communications raises a great many questions which beg to be answered. Questions concerning technical implementation of the DoD enhancements recommended herein, and under study at this time by other agencies, still require additional research. A few such technical items which need further study are:

- **Multimode MSS Handsets** - Research into a handset which could communicate with Globalstar, Iridium and a tactical cellular system.
- **Globalstar Deployable DoD Gateway** - Research into increasing the deployability of Globalstar Deployable DoD Gateway.
- **LPI/LPD Iridium Unit** - Research into developing a LPI/LPD Iridium Unit for strategic operations.
- **Iridium CSAR Unit** - Research into an Iridium unit which will enhance CSAR operations without sacrificing personnel safety.
- **Tactical Arena Mobile Communications System (TAMCS)**- Research into a TAMCS which would utilize both terrestrial and airborne assets.
- **Logistic Tracking Unit** - Research into the feasibility that a MSS unit could assist in tracking supplies in transit.
- **Battlefield Management Unit** - Research into the use of a MSS and TAMCS unit in a manner, such as SABER, to assist in overall battlefield management.
- **DoD-Owned MSS** - Research into various DoD-owned MSS options such as LEO, MEO and GEO DoD-Owned MSS constellations.

With the explosion of communications satellite technology, it is not a question of “if” but “when” world-wide mobile communications will be integrated into Naval communications, and what form it will take.

APPENDIX A

UHF SATCOM'S ABILITY TO SATISFY MRC REQUIREMENTS

The following analysis relies heavily upon information provided in Naval Space Command's Naval 1996 Satellite Communications Functional Requirements Document (Naval SATCOM FRD). In this document, C4I requirements were assessed for Naval forces involved in a single MRC. The Naval forces composition for one MRC was defined as follows:

- Carrier Battle Force
 - 1 Fleet Flagship
 - 4-5 Carriers
 - 8-10 Aegis Cruisers
 - 12-15 Destroyers
 - 12-15 Guided Missile Frigates
 - 12-15 Attack Submarines
 - 4-5 Fast Combat Logistics Support Ships
 - 4-5 Tenders
 - 8-10 T-AGOS Ships
 - 28-32 Mine Warfare Ships
- Amphibious Task Force
 - 4-5 Amphibious Assault Ships
 - 4-5 Amphibious Transport Dock Ships
 - 4-5 Landing Ship Dock Ships
 - 8-10 Escort Ships
 - 4-5 Additional Ships
- Marine Expeditionary Force
 - Command Element
 - SRIG
 - Force Recon Group

- Radio Battalion
- Intel Company
- Comm Battalion
- Ground Combat Element = One Division
 - Communications Company
- Air Combat Element = One Wing
 - Communications Squadron
- Combat Service Support Element = One FSSG
 - Communications Company

The summaries provided by the Naval SATCOM FRD were broken down into voice, data and video requirements. Of these categories, only voice and data requirements were considered as viable UHF SATCOM candidates. Within the voice and data requirements under consideration, the analysis excludes highly protected communications, as they are better suited to DoD-owned SHF and EHF satellite circuits. The data requirements were further restricted to low data rate (LDR) communications.

Naval one-MRC UHF SATCOM requirements were broken down into COMNAVFOR, CVBG, ARG, MARFOR, MEF and MEU circuit requirements in theater, taking the excluded items into account, and did not include ships in transit or support units held in reserve. Table A-1 below summarizes those circuit requirements.

CATEGORY	VOICE	DATA	TOTAL
COMNAVFOR	57	12	69
CVBG	294	162	456
ARG	120	75	195
MARFOR	71	10	81
MEF	250	60	310
MEU	30	17	47
TOTAL REQUIREMENTS	822	336	1158

Table A-1. Naval One MRC UHF Requirements.

The Navy's main UHF SATCOM resource will be DoD-owned UFO satellites. There will be two UFO satellites covering each AOR where a single MRC might occur. Each satellite has seventeen 25 kHz channels which can support up to four 2.4 kHz voice/data channels and one 5 kHz channel which can support one 2.4 kHz voice/data channel. UFO can therefore only satisfy a total of 138 of the 1158 LDR requirements of Naval forces in a one-MRC scenario. Commercial MSS could handle much of the remaining requirements Iridium can support up to 3840 circuits and Globalstar can support up to 2716 circuits in a MRC area of operations. The integration of commercial MSS with DoD-owned UHF satellite systems offers an order of magnitude increase in satellite communications capabilities as is depicted in Figure A-1.

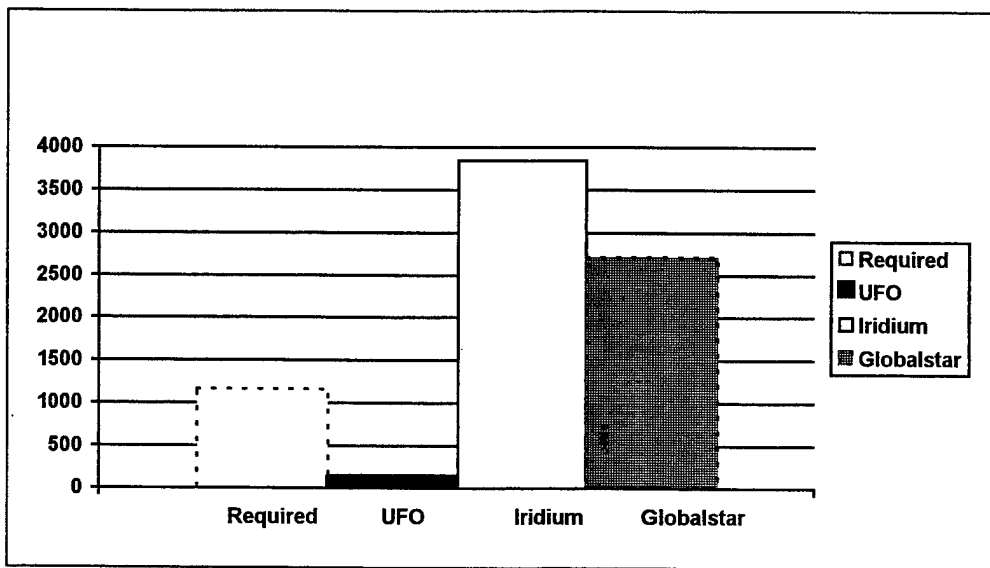

Figure A-1. Naval UHF Requirements Versus UFO, Iridium and Globalstar.

APPENDIX B

ACRONYMS

ADCS	Attitude Determination and Control Subsystem
AJ	Anti-Jam
AMPS	Advanced Mobile Phone Service
AOR	Area of Responsibility
AOR-W	Atlantic Ocean Region West
AOR-E	Atlantic Ocean Region East
AS	Anti-Scintillation
BER	Bit Error Rate
CDMA	Code Division Multiple Access
CMRC	Combined Major Regional Conflict
COMSEC	Communications Security
COTS	Commercial Off the Shelf
CSAR	Combat Search and Rescue
C2	Command and Control
dB	Decibels
DII	Defense Information Infrastructure
DISA	Defense Information Systems Agency
DSFRD	DoD's SATCOM Functional Requirements Document
DISN	Defense Information Systems Network
DoD	Department of Defense
DUSDS	Deputy Under Secretary of Defense for Space
EHF	Extremely High Frequency
EMI	Electromagnetic Interference
EMP	Electromagnetic Pulse
EPS	Electrical Power Subsystem
ERDB	Emerging Requirements Database
FCC	Federal Communications Commission
FDMA	Frequency Division Multiple Access
F/F	Fixed to Fixed
F/M	Fixed to Mobile
FO	Forward Observer
FSL	Free Space Loss
FSS	Fixed Satellite Service
F/T	Fixed to Transportable
Gateway	Land Earth Station
GBS	Global Broadcast Service
GCCS	Global Command and Control System
GDN	Globalstar Data Network
GEO	Geostationary Earth Orbit
GHz	Gigahertz
GOCC	Ground Operational Control Center
GPS	Global Positioning System
GSM	Global System for Mobile Communications
	Groupe System Mobile
HEMP	High Altitude Electromagnetic Pulse
HLR	Home Location Register

HSD	High Speed Data Service
ICDB	Integrated Communications Database
INMARSAT	International Maritime Satellite Organization
IOC	Initial Operational Capability
IOR	Indian Ocean Region
ISDN	Integrated Services Digital Network
ITU	International Telecommunication Union
ITW/AA	Intergrated Tactical Warning and Attack Assessment
JMCIS	Joint Maritime Command Information System
kbps	Kilobit per second
LEO	Low Earth Orbit
LOS	Line of Sight
LPD	Low Probability of Detection
LPI	Low Probability of Intercept
MCF	Mission Control Facility
MDU	Mission Data Update
MEO	Medium Earth Orbit
MHz	Megahertz
MILSATCOM	Military Satellite Communication
MLRC	Multiple Lesser Regional Conflict
M/M	Mobile to Mobile
MRC	Major Regional Conflict
MSS	Mobile Satellite Service/System
MUS WIPT	Mobile User Study Working Integrated Product Team
NCA	National Command Authority
NCS	Network Coordination Station
NOC	Network Operations Center
NNFR	Naval Narrrowband Functional Requirements
NSFS	Naval Surface Fire Support
NSA	National Security Agency
ORD	Operational Requirements Document
PCS	Personal Communications System
PLMN	Public Land Mobile Network
PN	Psuedorandom Number
POR	Pacific Ocean Region
PSTN	Public Switched telephone Network
QPSK	Quadrature Phase Shift Keying
RF	Radio Frequency
SATCOM	Satellite Communications
SCF	System Engineering Control Facility
SCOC	Satellite Control Operations Center
SCPC	Single Channel Per Carrier
SCS	System Control Site
SES	Ship Earth Station
SHF	Super High Frequency
SNR	Signal to Noise Ratio
SOCC	Satellite Operational Control Center
SU	Subsriber Unit
TAMCS	Tactical Arena Mobile Communications System
TDD	Time Division Duplexing
TDMA	Time Division Multiple Access

T/M	Transportable to Mobile
T&C	Telemetry and Command
T/T	Transportable to Transportable
TT&C	Telemetry, Tracking, and Control
UHF	Ultra High Frequency
VHF	Very High Frequency
VSAT	Very Small Aperture Terminal

APPENDIX C

GLOSSARY

Access Control. A technique used to define or restrict the rights or capabilities of individuals or application programs to communicate with other individuals or application programs and/or to obtain data from, or place data onto, a storage device. [Ref. 4]

Apogee. The point in a satellite's orbit that is farthest from Earth. [Ref. 8]

Attenuation. The reduction in strength of a radio signal. [Ref. 8]

Authentication. The process of verifying the identity of a user, terminal, application program, or service provider. This is a security measure designed to protect a communication system against acceptance of fraudulent transmission or simulation by establishing the validity of a transmission message or originator. [Ref. 4]

Bandwidth. The range of frequencies over which a system operates. [Ref. 8]

Bent-pipe. A satellite that receives a signal and retransmits it with no intervening processing. [Ref. 8]

Confidentiality. Assurance that information is protected against disclosure to unauthorized persons, programs, or systems. [Ref. 4]

Cover. To convert the transmitted waveform into an unusable form by means of communications and information security and cryptographic techniques. [Ref. 4]

Data Encryption Standard (DES). A cryptographic algorithm for the protection of unclassified computer data, issued as Federal Information Processing Standard Publication 46-1 and intended for public and Government use. [Ref. 4]

Demodulate. To separate an information signal from an RF carrier signal. [Ref. 8]

Demultiplex. The process of separating multiple bit streams from a single bit stream source. [Ref. 8]

Denial of Service. The prevention of authorized access to system assets or services, or the delaying of time-critical operations. [Ref. 4]

Downlink. The signal path from the satellite to the Earth. [Ref. 8]

Dual Mode. Describes a mobile terminal that interfaces with local telephone cellular networks and, if no local cellular network is available, the terminal interfaces directly with a satellite. [Ref. 8]

Eavesdropping. The unauthorized interception of information-bearing emanations through the use of methods other than wiretapping. [Ref. 4]

Eccentricity. The degree to which an orbit deviates from a circle. [Ref. 8]

Encrypt. To convert plain text into a form unintelligible to entrusted individuals or processes by means of a crypto system. Encryption also supports authentication and may support information integrity and access control. [Ref. 4]

Gateway Station. An earth station that interfaces with the satellite network through some other network, such as the PSTN. [Ref. 8]

Information Integrity. Assurance that information, data, programs, and other system resources are protected against malicious or inadvertent modification or destruction by unauthorized persons, programs, or systems. [Ref. 4]

Intrusion. The act of joining a communications circuit without permission or authority, usually with the intention of causing a distraction or disrupting communications. [Ref. 4]

Landing Rights. Permission to operate a satellite in a country. This is granted by the affected country with possible ITU input. [Ref. 8]

Masquerading. Assuming the identity of another party that has authorization to perform operations not authorized for some parties. [Ref. 4]

Mobile Satellite Systems/Service. Systems/services that allow subscribers direct access to a satellite. Mobile satellite systems/services range from fixed GEO satellite service to individuals to service from nonstationary, LEO satellites. [Ref. 4]

Modulate. To combine an information signal with an RF signal so that the transmitted RF signal "carries" that information to an intended receiver. [Ref. 8]

Monitoring. The observation of information passing between users over a communications channel. [Ref. 4]

Multipath. A situation in which a receiver simultaneously receives at least two delayed radio signals from reflections that interfere with each other. [Ref. 8]

Multiplex. The process of creating a single bit stream from multiple bitstream sources. [Ref. 8]

Noise. Undesired signals affecting the communications channel; usually random in behavior. [Ref. 8]

Null. A point at which signal cancellation occurs. [Ref. 8]

Orbital Window. There are two usages for this term. In the case of an operational GEO satellite, this refers to the maintenance of that satellite within the tolerances of its assigned

location. In the case of a non-GEO satellite, it refers to the time period in which that satellite is in view above a minimum elevation angle of an earth terminal. [Ref. 8]

Paging Service. A one-way wireless radio service to provide a message to the subscriber. [Ref. 4]

Perigee. The point in a satellite's orbit that is closest to Earth. [Ref. 8]

Period. The time required for a satellite to make one revolution about the earth. [Ref. 8]

Privacy. The ability to control or influence access to user information and protect such information from disclosure. [Ref. 4]

Propagation. The travelling of a radio signal outward from its source. [Ref. 8]

Scintillation. The rapid fluctuation of radio signals due to variations in propagation media. [Ref. 8]

Secure Telephone Unit (STU). A U.S. Government-approved telecommunications terminal designed to protect the transmission of sensitive or classified information in the voice, data, and facsimile modes. [Ref. 4]

Security. The condition achieved when designated information, material, personnel, activities, and installations are protected against espionage, sabotage, subversion, and terrorism as well as against loss or unauthorized disclosure. The term is also applied to those measures necessary to achieve this condition. [Ref. 4]

Shadowing. A situation where a radio signal is blocked by physical objects in the path. [Ref. 8]

Shaped Beam. A beam shaped to cover a desired contour. [Ref. 8]

Spot Beam. A concentrated narrow beam with a relatively small footprint. [Ref. 8]

Spread Spectrum. A signal-structuring technique that employs direct sequence, frequency hopping, or a hybrid of these, which can be used for multiple access and/or multiple functions. This technique decreases the potential interference to other receivers while achieving privacy and increasing the immunity of spread-spectrum receivers to noise and interference. Spread spectrum generally makes use of a sequential noise-like signal structure to spread the normally narrowband information signal over a relatively wide band of frequencies. The receiver correlates the signals to the original information signal. [Ref. 4]

Traffic Flow Analysis. The analysis of traffic and signalling patterns over time, in the hope that pattern changes may indicate identifiable changes in operations or provide intelligence about a target individual or organization. [Ref. 4]

Transponder. The electronic device on a satellite that transforms the received signal into a form suitable for retransmission. [Ref. 8]

Uplink. The signal path from the Earth to the satellite. [Ref. 8]

Window. The time period in which a satellite is in view of a site on Earth (also called orbital window). [Ref. 8]

Zone Beam. A shaped beam to cover a specific area. [Ref. 8]

LIST OF REFERENCES

1. Wisloff, Tor E., *Tor E. Wisloff's Tabulated Overview of Big LEO's*, <http://www.idt.unit.no/~torwi/tables.html>, 15 May 1997.
2. Dalton, John H., *Forward ...From the Sea*, The Department of the Navy, Washington, D.C., 1994.
3. Naval Doctrine Command, Naval Warfare, Naval Doctrine Publication 1, The Department of the Navy, Washington D.C., 28 March 1994.
4. Joint Chiefs of Staff, *Doctrine for Command, Control, Communications, and Computer (C4) Systems Support to Joint Operations*, Joint Pub 6-0, Washington, D.C. 30 May 1995.
5. D8, *DoD Satcom Functional Requirements Document, Defense Information Systems Agency*, 7 February 1996.
6. United States Space Command, *DoD Advanced Satellite Communications Capstone Requirements Document (Draft)*, USSPACCOM, 10 June 1996.
7. Boyd, Austin, *Mobile Users Study Requirements Working Integrated Product Team*, Naval Space Command, 16-17 April 1997.
8. Eppink, James, Morris, Michelle and McRae, Lymuel, *Mobile Satellite Communications: An Overview of Systems and Concepts*, U.S. Department of Defense, January 26, 1996.
9. Naval Space Command (N52), *Commercial Satcom, Satisfying Naval Requirements*, August 1996.
10. Freeman, Roger L., *Telecommunication Transmission Handbook*, 3rd Edition, John Wiley & Sons, Inc., 1991.
11. Martin, Donald H., *Communications Satellites 1958-1995*, Aerospace Corporation, May 1996.
12. Wilson, Andrew, *Janes Space Directory Eleventh Edition*, Janes Information Group Ltd., 1995.
13. COMSAT, *A World Apart a World Connected*, COMSAT, 1996

14. Ziegler, Michael, *Enhancing the Naval Warfighter's Communications: Rapid Emergence in Use of Commercial Satellite Communications on Navy Ships at Sea*, AIAA 1995 Space Programs and Technologies Conference, September, 26-28 1995.
15. COMSAT Team, *Commercial Satellite Communications Initiatives Volume II, MSS System Engineering Studies and Capabilities*, DISA, February 1, 1993.
16. Mandsager, D.L., *Use of INMARSAT During Armed Conflict*, Office of the Judge Advocate General, 14 January 1991.
17. D'Ambrosio, Wayne, *Digital INMARSAT Contract Services and Prices*, COMSAT, July 1996.
18. Santiano, Aurora, *The Turning Point, INMARSAT Competitive Systems*, INMARSAT, 24 September 1996.
19. Windolph, John, *Iridium Background Information*, Iridium Inc., August 1996.
20. Maine, Kris, Devieux, Carrie and Swan, Pete, *Overview of Iridium Satellite Network*, IEEE Potentials, August 1995.
21. Cutler, Dave, *Global Telecommunications Gets Personal*, Iridium Today Volume 2 Number 4, Iridium Incorporated, June 1996.
22. Wood, Loyd, *Iridium.html*, <http://www.ee.surrey.ac.uk/Personal/L.Wood/constellation>, May 7, 1997.
23. Savi Project, *Contellations.html*, <http://www.geom.umn.edu/~worlfolk/SaVi/>, University of Minnesota, March 1, 1996.
24. AT&T, *Mobile Satellite Viability Assessment*, September 1996.
25. Putz, Neil L., *Mobile Satellite Services, Enabling Global Leaders*, Joint Chiefs Of Staff, May 1996.
26. Globalstar, *Globalstar Backgrounder*, Globalstar LP, 6 December 1996.
27. Long, Steven, *Globalstar Overview Brief*, Globalstar LP, 16 April 1997.
28. Globalstar, *satellite.htm*, <http://www.globalstar.com/system/>, Globalstar LP, 11 June 1997.
29. Globalstar, *gcc.htm*, <http://www.globalstar.com/system/>, Globalstar LP, 11 June 1997.

30. Globalstar, *gateway.htm*, <http://www.globalstar.com/system/>, Globalstar LP, 11 June 1997.
31. Globalstar, *user.htm*, <http://www.globalstar.com/system/>, Globalstar LP, 11 June 1997.
32. Schindall, Joel, *Concept and Implementation of the Globalstar Mobile Satellite System*, International Mobile Satellite Conference, Ottawa, Canada, 1995.
33. Henderickson, Rich and Penwarden, Kent, *Globalstar for the Military*, Globalstar L.P., SanJose, California, 1996.
34. Naval Security Group Command, *Project Starcross: Mobile Satellite Systems Assessment: Phase II* October 1996.
35. D'Ambrosio, Wayne, *Thesis Meeting with INMARSAT Navy Sales Manager*, COMSAT, 15 Dec 1996.
36. Iridium LLC, *Iridium Background Information*, August 1996.
37. Strategic Secure Voice Systems, *The Condor Wireless Initiative*, National Security Agency, March 1997.
38. Putz, Neil, *General Officer's Mobile Satellite Services Brief*, Joint Staff, November 1996.
39. Hendrickson, Rich, *Globalstar for the Military*, Globalstar L.P., 1996.
40. Long, Steven, *Secure Netted Broadcast Communications for the Digital Battlefield*, Qualcomm, 15 April 1997.
41. Kerrigan, Don, *Thesis Meeting with J6T*, Joint Staff, 4 December 1996.

INITIAL DISTRIBUTION LIST

1. Defense Technical Information Center..... 2
8725 John J. Kingman Rd., STE 0944
Ft. Belvoir, Virginia 22060-6218
2. Dudley Knox Library 2
Naval Postgraduate School
411 Dyer Rd.
Monterey, California 93943-5101
3. DoD Space Architect 2
Attn: CDR David A. Baciocco
2461 Eisenhower Ave, Suite 164
Alexandria, Virginia 22331-0900
4. Dr. Rudolf Panholzer 1
Code SP
Naval Postgraduate School
Monterey, California 93943-5101
5. Professor Donald Wadsworth..... 1
Code EC/WD
Naval Postgraduate School
Monterey, California 93943-5101
6. Professor Brig Agrawal..... 1
Code AA/Ag
Naval Postgraduate School
Monterey, California 93943-5101
7. Office of the Chief of Naval Operations..... 1
OPNAV N633, Attn: LCDR J.J. Shaw
Washington, D.C. 20350
8. Office of the Joint Staff..... 1
J-6T, Attn: CDR Don Kerrigan
Pentagon
Washington, D.C. 20350
9. Commander, Naval Space Command 2
N-5 Attn: CDR Austin Boyd
Dahlgren, Virginia 22448-5170
10. LT Cary Reese Stone..... 2
1009 Waite Ave
Eldersburg, Maryland 21784