

25  
3

OTS: 60-11,604

JPRS: 2632

9 June 1960

RESEARCH TO MAIN FILE

AN INSTRUMENT FOR RECORDING ACCELERATIONS AND INCLINATIONS  
IN DETERMINATIONS OF THE FORCE OF GRAVITY AT SEA

USSR -

by V. V. Sukhodol'skiy

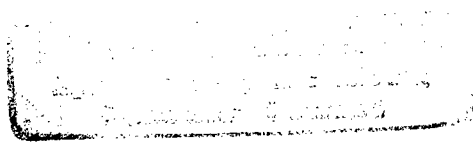

U.S. GOVERNMENT PRINTING OFFICE

19980115 000

Distributed by:

OFFICE OF TECHNICAL SERVICES  
U. S. DEPARTMENT OF COMMERCE  
WASHINGTON 25, D. C.

Price: \$0.50

U. S. JOINT PUBLICATIONS RESEARCH SERVICE  
205 EAST 42nd STREET, SUITE 300  
NEW YORK 17, N. Y.

JPRS: 2632

CSO: 3681-N/a

AN INSTRUMENT FOR RECORDING ACCELERATIONS AND INCLINATIONS  
IN DETERMINATIONS OF THE FORCE OF GRAVITY AT SEA

[This is a translation of an article written by V. V. Sukhodol'skiy in Izvestiya Ak Nauk SSSR, Seriya Geofizicheskaya (News of the Academy of Sciences USSR, Geophysics Series), No. 11, 1959, pages 1570-1578.]

A description is given of the RNvu instrument, which registers inclinations and accelerations of the base of a gravimetric instrument when used to determine the force of gravity at sea; the principal data and characteristics of the instrument are given.

Purpose of the RNvu Instrument and Principal  
Computational Data

When the force of gravity at sea is determined by means of surface ships, the inclinations and accelerations influence greatly the results of the measurement, and their effect must be taken into account. As was already shown by Wening-Meines, Braun, and L. V. Sorokin, in marine gravimetric observations it is necessary to register the inclinations and horizontal accelerations in two mutually-perpendicular directions, and also the vertical accelerations of the base of the instrument.

For this purpose, the author of this article developed in 1955 a registering instrument (RNvu), consisting of two inclination-measuring long-period pendulums and a vertical accelerometer.

The two horizontal accelerometers were mounted directly on the stand of the pendulum instrument in such a manner, that they were recorded on photographic film simultaneously with the recordings of the readings of the real and fictitious pendulums.

The experimental shop of the Special Construction Bureau (SKB) for Geophysical Instrument Building of the Institute of Earth Physics, Academy of Sciences USSR, has built in 1955 two NRvu instruments and a set of horizontal accelerometers; these were used by the expeditions of the Academy of Sciences USSR in 1955-1957.

The principal parameters of the accelerometers, namely the natural oscillation period and the damping constant of the pendulums,

were computed on the basis of the following considerations.

The motion of the base of the gravimetric instruments, in the case of observations at sea, can be considered to be almost harmonic.

The displacement and the acceleration of the mounting can be represented here in the form

$$x(t) = x_m \cdot \sin \omega t, \quad (1)$$

$$\ddot{x}(t) = -x_m \cdot \omega^2 \cdot \sin \omega t, \quad (2)$$

where  $x_m$  -- amplitude of oscillation of the base of the instrument;

$\omega = \frac{2\pi}{T_\omega}$  -- the circular frequency of of oscillation;  $t$  - time.

The amplitude of oscillation of the accelerometer pendulum is determined on the recording from the equation

$$y = -v_0 \cdot U_1 \cdot x(t). \quad (3)$$

To reconcile the recording with the actual accelerations it is necessary that the frequency characteristic of the accelerometer have the following form

$$U_1 = c \cdot \omega^2. \quad (4)$$

Then

$$y = -v_0 c \cdot \omega^2 x(t) = v_0 c \cdot \ddot{x}(t). \quad (5)$$

The equation of the frequency characteristic of the pendulum [1] has the form

$$U_1 = \frac{1}{\sqrt{(1 - u_1^2)^2 + 4D_1^2 u_1^4}}, \quad (6)$$

where  $u_1 = \frac{n_1}{\omega}$ ;  $n_1 = \frac{2\pi}{T_1}$ ,  $D_1$  -- the damping constant of the pendulum,

and  $T_1$  is the period of the natural oscillations of the pendulum.

It is easy to see that

$$U_1 = \frac{1}{u_1^2} \cdot \frac{1}{\sqrt{1 + \left( \frac{1}{u_1^4} + \frac{4D_1^2 - 2}{u_1^2} \right)}}, \quad (7)$$

or

$$U_1 = \frac{1}{u_1^2} \cdot \frac{1}{\sqrt{1 + x}}, \quad (8)$$

where

$$x = \left[ \frac{1}{u_1^4} + \frac{2(2D_1^2 - 1)}{u_1^2} \right], \quad (9)$$

and consequently

$$y = -\frac{v_0}{\pi_1^2} \cdot \omega^2 \cdot x(t) \frac{1}{\sqrt{1+x}}. \quad (10)$$

The recording will correspond to the actual accelerations, if in Eq. (10)  $\frac{1}{\sqrt{1+x}} \approx 1$ , i. e.  $x \ll 1$ .

The error in the amplitude is

$$\alpha = \frac{1}{2}x = \frac{1}{2} \left[ \frac{1}{u_1^4} + \frac{2(2D_1^2 - 1)}{u_1^2} \right]. \quad (11)$$

Specifying an error of one percent ( $\alpha = 0.01$ ) and using a damping constant  $D = 0.4$  as recommended for our case, we determine the period of natural oscillations  $T_1$  of the accelerometer pendulum

$$T_1 \leq \frac{T_{\text{min}}}{8.25}. \quad (12)$$

On the basis of data of marine gravimetric expeditions,  $T_{\text{min}} = 4$  sec. Consequently,  $T_1 = 0.48$  sec, i. e., for accelerometer calculations one can assume  $T_1 = 0.45$  sec. We then obtain from the formula  $T_1 = 2\pi \sqrt{\frac{l}{g}}$  a value  $l = 5$  cm for the reduced length, and by using the formula

$$l = \frac{K_p}{M \cdot R_0}, \quad (13)$$

we can readily determine the dimension of the pendulum elements.

The moments of inertia about the axes passing through the centers of gravity of the pendulum elements are considerably smaller than the moments of inertia of the masses of the pendulum elements about its own axis of rotation. Therefore, in the design of the pendulum one can use the equation

$$K_p \cong M_1 R_{01}^2 + M_2 R_{02}^2. \quad (14)$$

where  $K_p$  is the moment of inertia of the pendulum,  $M_1$  and  $M_2$  are the masses of the pendulum elements,  $R_{01}$  and  $R_{02}$  are the distance from the axis of rotation to the center of gravity of the pendulum elements. From constructional considerations (Fig. 1), we specify dimensions for the masses  $M_1$  of the pendulum and  $M_2$  of the damping plate, and also the distance  $R_y$  between their centers of gravity.

Solving simultaneously Eqs. (13) and (14), and substituting  $R_{02} = R_{01} + R_y$ , we obtain the values of  $R_{01}$  and  $R_{02}$ .

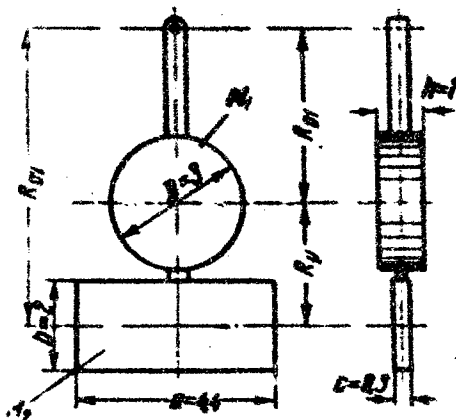

Fig. 1. Diagram of horizontal accelerometer

In direct registration [1] the damping constant of the pendulum is  $D_1 = D_{10} + D_{1d}$ , where  $D_{10}$  is the fraction of damping due to absorption of energy by purely mechanical means (air resistance, friction in the suspension, etc.);  $D_{1d}$  is the fraction of damping due to interaction of electric eddy currents, which are produced in the damping plate as it moves in the magnetic field of the magnet.

Since the pendulum oscillates on a shaft of very small diameter, supported by agate bearings, the friction in the pendulum suspension will be small. The value of  $D_{10}$  is many times smaller than the value of  $D_{1d}$ ; one can therefore disregard the damping fraction  $D_{10}$  and to use in the damper design the approximate equation

$$D_1 = D_{1d} \quad (15)$$

In the case of damping due to eddy currents [1]

$$D_{1d} = \frac{c \cdot \lambda \cdot H^2 V \cdot L_D^2}{2 \cdot K_p \cdot n \cdot p} = D_1 \quad (16)$$

where H is the intensity of the magnetic field in the armature gap (oersteds);  $\lambda$  -- the electric conductivity of the material of the plate ( $\text{ohm}^{-1}\text{mm}^2$ ); V -- the volume of the damping plate, located in the magnetic field ( $\text{cm}^3$ );  $L_0$  -- the distance from the pendulum axis to the center of the damping plate (cm);  $K_p$  -- the moment of inertia of the pendulum about its own axis ( $\text{g}\cdot\text{cm}^2$ );  $n_p$  -- angular frequency of the pendulum's natural oscillations;  $\bar{c}$  -- a coefficient which depends on the form of the damping plate (experimentally determined). For a plate of rectangular form, projecting outside the air gap of the magnet at least half the width of the pole pieces,  $\bar{c} = 4 \times 10^{-6}$ . In the design of the magnetic system we will put  $D = 0.4$ . When a damping plate of red copper is used to construct the damper,  $\lambda = 57 \text{ mm}^2/\text{ohm}$  [1]. Inserting these values in Eq. (16) we determine the value of  $H_1$  of the magnetic system of of damper

$$H_1 = \sqrt{\frac{2 \cdot K_p n_p^2 \bar{c} \cdot D_1}{\bar{c} \cdot \lambda \cdot v \cdot L_0^2}}$$

From theoretical calculation of the influence of corrections on the inclinations and accelerations that act on a pendulum instrument in a Cardan suspension, we obtain the following: a) when the period of the perturbing influences is greater than 2 -- 3 sec, the horizontal accelerometers with natural oscillation periods of less than one second register the angle  $\theta_u$  between the instantaneous vertical and the geometric axis of the instrument (Fig. 2):

b) inclination-measuring pendulums with natural oscillation periods of 30-40 sec. register the angle  $\alpha$  between the geometric axis of the instrument and the true vertical when the period of the perturbing influences is less than 15 or 20 sec.

To record vertical accelerations, one uses a pendulum which responds weakly to horizontal accelerations and inclinations. This condition is best satisfied if the center of gravity of the pendulum lies in the same horizontal plane as its axis of rotation. The pendulum is maintained in such a position with the aid of a spring.

To register vertical accelerations we use a pendulum with the damper, the design of which was given above, using a spiral spring to maintain the pendulum in a horizontal position (Fig. 3).

To insure the specified period of natural oscillations in the pendulum, it is necessary to select a spiral spring which maintains the pendulum in a horizontal position.

The stiffness of the spring  $C_p$  is determined from the following relations [1]:

$$C_p = \frac{n_p^2 \cdot K}{a^2} \quad (17)$$



formula

$$C_p = \frac{G \cdot d^4}{64 \cdot N \cdot R^3}, \quad (18)$$

Where  $G$  is the shear modulus ( $8 \times 10^{11}$  g/cm-sec. for steel).

From the magnitude of the force  $F$  stretching the spring we determine the elongation of the spring

$$y_{\text{Spr}} = \frac{F}{C_p}.$$

The length of the spring, with allowance for its elongation under the influence of the force  $P_p = P_1 + P_2$ , is determined from the equation

$$l_{\text{Spr}} = N \cdot d + y_{\text{Spr}}$$

In order for an inclination-measuring pendulum to maintain a horizontal position with sufficient reliability while the inclinations of the instrument vary with a period  $T = 4 \text{ -- } 12$  sec, its natural oscillation period should be on the order of  $30 \text{ -- } 40$  sec.

The construction of the vertical pendulum with the center of gravity located near its axis of rotation insures, at relatively small dimensions, the required period of natural oscillations.

It was proposed earlier (Wening-Meines, L. V. Sorokin) to use for this purpose a construction of a long-period pendulum oscillating on an agate knife edge.

In such a long-period pendulum the friction between the knife and the agate bearing is very small, and when the center of gravity of the pendulum shifts relative to the knife edge by a very small quantity it is possible to obtain a restoring torque, sufficient to overcome the resistance forces.

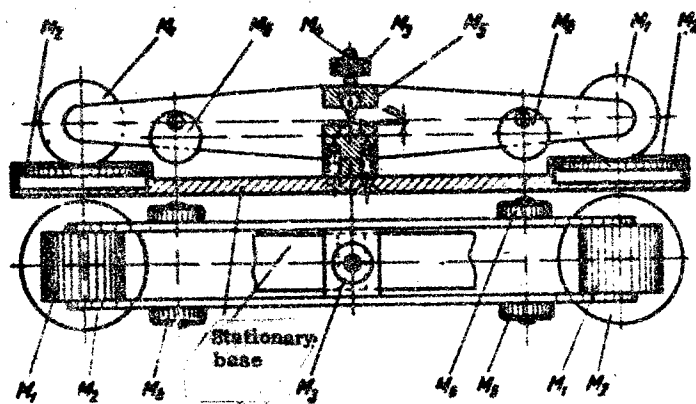

Fig. 4  
Diagram of inclination-measuring pendulum

From Eq. (13) it is seen that to obtain a pendulum with a large reduced length it is necessary to construct such a pendulum, which would have a considerable moment of inertia with relatively small mass.

In addition, the construction of the pendulum should provide for the possibility of shifting the center of gravity of the pendulum relative to the knife edge, by means of a micrometer-mounted additional weight, so that the value of  $R_0$  can be set on the order of 20--30 . From these considerations, we determine the required dimensions of the principal elements of the pendulum (Fig. 4).

Knowing the dimensions of the pendulum elements, the size of the masses, and the position of the center of gravity, we determine the moment of inertia of the pendulum  $K_p$  about its axis of oscillation.

The natural period of oscillations of a long-period pendulum, with a moment of inertia  $K_p = 41120 \text{ g-cm}^2$ , could be reduced to 36 sec, using air damping with the aid of a dash pot to damp out the oscillations of the pendulum.

#### Accelerometers and Inclination-Measuring Pendulum

The horizontal accelerometer is a pendulum, whose axis rotates in a housing with agate bearings (Fig. 5).

Thanks to the small diameter of the shaft, the friction in the agate bearing is very small. Secured to the rod of the pendulum is a mirror, which reflects light from an illuminator unto a photographic film of the registering portion of the marine pendulum instrument.

When the pendulum oscillates, the damping plate, made of red copper, moves in the gap of a magnetic system, consisting of two pole pieces made of Armco steel and a magnet made of Magnico alloy, placed between them.

By rotating a special knob the pendulum can be locked and unlocked.

The construction of the vertical accelerometer is analogous to the construction of the horizontal accelerometer, differing only in the presence of the spring, which maintains the pendulum in a horizontal position, and a device to regulate the tension of the spring (Fig. 6).

A long-period pendulum with air damping consists of a rocker arm with a built in agate knife and screw rod, on which an adjusting mass is located (Fig. 7).

The rocker arm with the details mounted on it rocks freely on an agate knife, the edge of which rests on agate bearings. On the base, in addition to the agate bearings, are secured the dashpot cylinder and the locking device.

Fastened on the pendulum are pistons, which enter with a gap of 1.2 mm, and the cylinders of the dashpot.

As the pendulum rocks, air damping is produced by the displacement of the pistons in the cylinders. To increase the degree of damping, grooves are cut on the inner surface of the cylinders, which produce turbulent air motion as the piston moves.

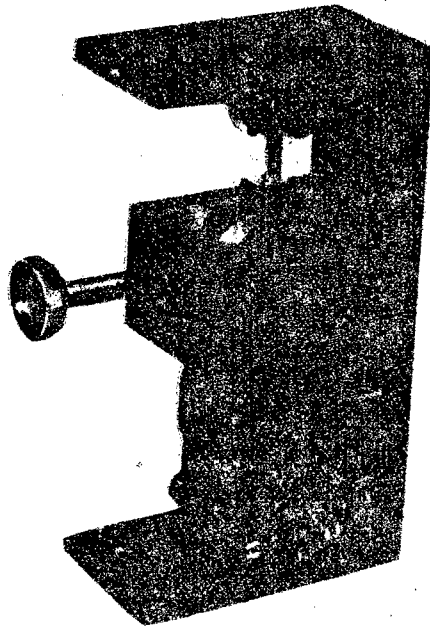

Fig. 5  
Overall view of a horizontal accelerometer with cover removed.

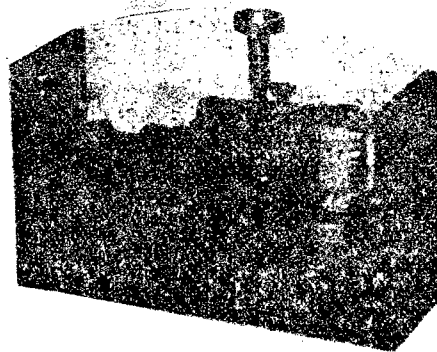

Fig. 6  
Overall view of vertical accelerometer.

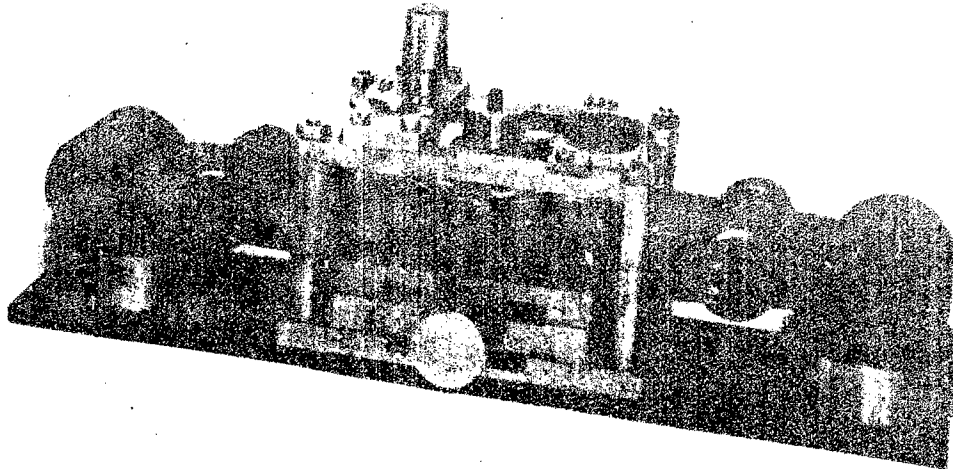

Fig. 7  
Overall view of inclination-measuring accelerometer.

On the rocker of the pendulum is a mirror, which reflects the rays of light unto the photographic film of the registering portion of the instrument.

The pendulum is locked by means of a special knob, which rotates the rising eccentric of the clamping device. The locking device has a self-stopping device, which guards against spontaneous unlocking of the pendulum.

Before the start of the observations, in order to carry out recordings of the period of natural oscillations of the pendulum, it is necessary to deflect it by a certain angle, and for this purpose a starting device is provided in the inclination-measuring pendulum.

The pendulum is started by loading the rocker arm with a miniature wire ring weighing a few milligrams. This disturbs the equilibrium of the pendulum, which deflects by a certain angle.

#### Recorder of Inclinations and Accelerations (RNVU)

The recorder of inclinations and accelerations (RNVU) is mounted during the time of observations on the housing of the pendulum instrument. In the housing of the instrument are mounted the two inclination pendulums and one vertical accelerometer. Two horizontal accelerometers are placed directly in the pendulum instrument, and the recording is produced at the same time with the recording of the actual and fictitious pendulum on a single photographic film.\*

\*In those cases when the accelerometers are located near invar pendulums or quartz pendulums with invar heads, it was recommended that the pendulums of the accelerometers be damped by a liquid damping method instead of magnetic.

Moving in the vertical guides of the housing is a film cassette, which holds 10 m of film of 60 mm width. When the cassette moves into the housing of the instrument, the light-type blind which covers the slit in the cassette opens automatically.

Mounted in the RNVU instrument is a slit time marker of the relay type, which is operated by a contact-making chronometer or some other contact making mechanism and which produces time markers over the entire width of the photographic film in the form of some transverse lines.

The RNVU instrument permits registration at three film speeds:  $v_1 = 0.75$ ,  $v_2 = 1.5$ , and  $v_3 = 3.0$  mm/sec.

Fig. 8 shows the optical diagram of the RNVU instrument. Light from the straight-filament lamp  $L_1$  passes through prism  $P_1$  and condenser C and falls on the group of mirrors  $M_1$  --  $M_6$ , which then deflect the light rays unto mirrors  $M_{11}$  and  $M_{12}$ , of the inclination-measuring pendulums and on mirror MA of the vertical accelerometer pendulum.

After passing through objectives  $O_1$  (spherical lenses), located in front of the mirror of each pendulum, and being reflected from the latter, the light rays again pass through the objectives  $O_1$  and are reflected by the mirrors  $M_1$ -- $M_6$  on a photographic film, which is wound by the drive shift DS of the cassette. The cylindrical lens CL, located in front of the photographic film, gathers the images of the vertical filament of the lamp into bright spots of light.

Fig. 9 shows the kinematic diagram of the instrument. The electric motor E joined through a worm gear reduction WG with a gear-change box, drives the winding mechanism of the cassette. The takeup for the cassette TU rotates uniformly, and therefore the kinematic link between it and the idler spool contains a friction device, insuring the slipping of the latter as it becomes filled up with film. The speed is changed by shifting the inter changeable gears  $Z_{22}$ ,  $Z_{33}$ , and  $Z_{44}$ .

Fig. 10 shows the electric diagram of the RNVU instrument. Connected to the terminals PT is 12 v dc. The switch CS connects the current to the electric supply of the instrument. Simultaneously it connects the signal lamp SL and the lamp STs-79 (2.5 v and 2.8 amp) of the pendulum illuminator PI. The switch MS connects the electric motor E, which has terminals RMT for remote control. When the motor is turned on the rewinding of the film begins.

The switch TM closes the circuit of the relay time marker RM, which is operated by the chronometer through a polarized relay. Connected in the circuit of the STs-78 lamp (7 v and 0.5 amp) of the time marker illuminator is a supplementary resistance SR, which reduces the tube filament voltage to 7 volts. The necessary filament current in the illuminator lamp, depending on the speed of motion of the photographic film and its sensitivity, is set by

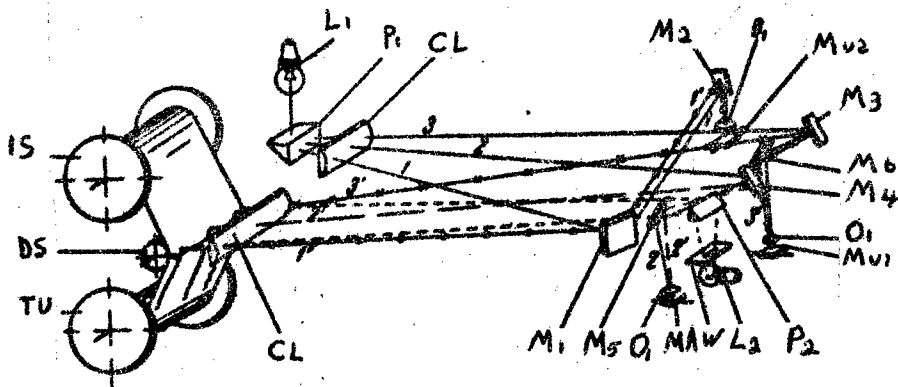

Fig. 8  
 Optical diagram of the RNVU instrument.  $L_1$  -- lamp of pendulum illuminator,  $L_2$  -- lamp of time marker illuminator,  $P_1$  -- prism, C -- condenser lens,  $M_1$  --  $M_6$  -- reflecting mirrors,  $P_2$  -- time marker prism, B -- blind of slit time marker of relay type,  $M_{i1}$ ,  $M_{i2}$  -- mirrors of inclination-measuring pendulums, MA -- mirror of vertical accelerometer,  $O_1$  -- objectives, CL -- cylindrical lens, DS -- drive shaft, IS -- idler spool, TU -- takeup spool.

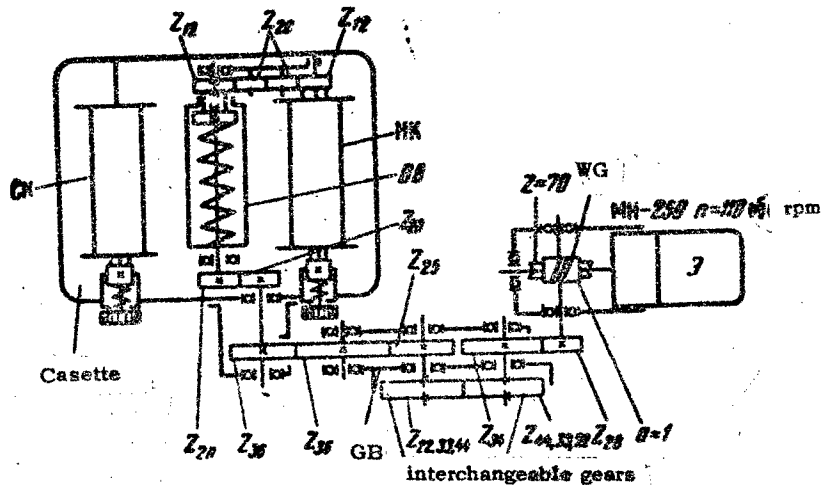

Fig. 9  
 Kinematic diagram of the RNVU instrument. E -- electric motor, WG -- worm gear, DS -- driving shaft, IS -- idler spool, TJ -- takeup spool, GB -- gear box, Z -- gears.

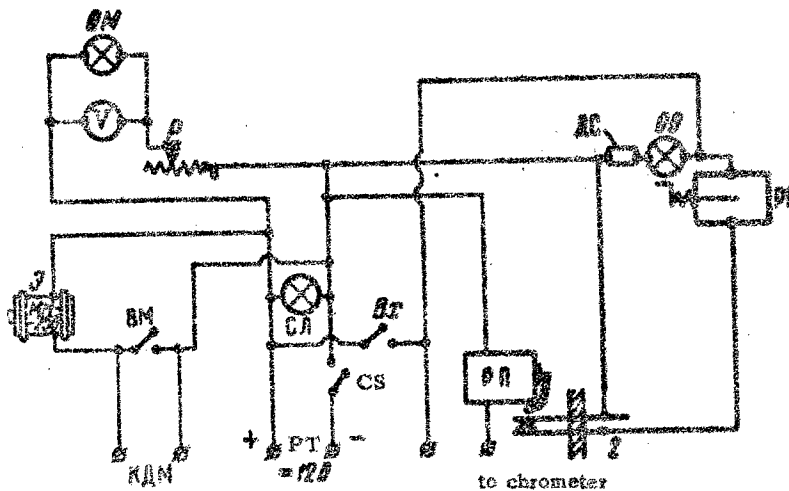

Fig. 10

Electric diagram of the RNVU instrument. E -- electric motor, PT -- power terminals of the instrument, CS -- common switch, SL -- signal lamp, PI -- lamp of pendulum illuminator, V -- voltmeter, R -- rheostat, MS -- motor switch, KAM -- remote control terminals for motor, IM -- relay time marker, 3R -- lamp of time marker illuminator, 3R -- supplementary resistance, TM -- time marker switch, PR -- polarized relay.

means of rheostat R.

The total power consumed by the instrument is 18 watts at 12v.

The tests made on the RNVU instrument in horizontal accelerometers have shown that the pendulums of the accelerometers and inclination meters have the following data.

1. Pendulum of vertical accelerometer. Natural oscillations period  $T = 0.25$  sec, sensitivity at an optical arm of 550 mm -- acceleration of 1 gal represents 0.34 mm on the recording.

2. Pendulum of horizontal accelerometers. Period of natural oscillations  $T = 0.45$  sec, sensitivity at an optical arm of 1000 mm -- 2.05 mm correspond to an acceleration of 1 gal.

3. Inclination-measuring pendulums. Period of natural oscillations  $T_1 = 39$  sec,  $T_2 = 36$  sec; sensitivity at an optical arm of 550 mm -- 19.2 mm on the recording corresponds to an angle of inclination  $1^\circ$ .

4. Sensitivity of the pendulums of the horizontal accelerometers to inclinations, at an optical arm of 1000 mm -- 34.9 mm on the recording corresponds to an angle of inclination of  $1^\circ$ .

5. The RNVU instrument makes it possible to register

\* inclinations up to  $\pm 2^\circ$  and vertical accelerations up to  $\pm 85$  gal. 7

The period of natural oscillations of the pendulum of the vertical accelerometer is less than the calculated value, since in the manufacture of the vertical accelerometer a spring was inserted in the instrument, which maintains the pendulum in a horizontal position with greater stiffness than assumed in the calculations.

The dimensions of the RNVU instrument with the cassette are 540 x 390 x 260 mm. The instrument with two cassettes weights 21 kg.

In 1957 the RNVU instruments were modernized, so as to double the range of registration of inclinations and vertical accelerations.

In the modernized instrument a new cassette is used, which holds 12 m of film 120 mm wide. The dimensions and weight of the instrument remain unchange .

At the present time the modernized RNVU-M instruments are used in marine expeditions of the Academy of Sciences, USSR.

Academy of Sciences USSR,  
Institute of Earth Sciences

Received 7 February 1959

#### Bibliography

1. Kirnos, D. P., Certain Problems in Instrumental Seismology. Trudy Geofiz. in-ta AN SSSR [Works of the Geophysical Institute, Academy of Sciences USSR] No. 27, 1955.

This publication was prepared under contract to the  
UNITED STATES JOINT PUBLICATIONS RESEARCH SERVICE  
a federal government organization established  
to service the translation and research needs  
of the various government departments.