

282078

JPRS-JST-86-023

29 AUGUST 1986

Japan Report

SCIENCE AND TECHNOLOGY

DISTRIBUTION STATEMENT A

Approved for public release;
Distribution Unlimited

19980218 088

FBIS

FOREIGN BROADCAST INFORMATION SERVICE

REPRODUCED BY
NATIONAL TECHNICAL
INFORMATION SERVICE
U.S. DEPARTMENT OF COMMERCE
SPRINGFIELD, VA. 22161

19
75
A44

NOTE

JPRS publications contain information primarily from foreign newspapers, periodicals and books, but also from news agency transmissions and broadcasts. Materials from foreign-language sources are translated; those from English-language sources are transcribed or reprinted, with the original phrasing and other characteristics retained.

Headlines, editorial reports, and material enclosed in brackets [] are supplied by JPRS. Processing indicators such as [Text] or [Excerpt] in the first line of each item, or following the last line of a brief, indicate how the original information was processed. Where no processing indicator is given, the information was summarized or extracted.

Unfamiliar names rendered phonetically or transliterated are enclosed in parentheses. Words or names preceded by a question mark and enclosed in parentheses were not clear in the original but have been supplied as appropriate in context. Other unattributed parenthetical notes within the body of an item originate with the source. Times within items are as given by source.

The contents of this publication in no way represent the policies, views or attitudes of the U.S. Government.

PROCUREMENT OF PUBLICATIONS

JPRS publications may be ordered from the National Technical Information Service, Springfield, Virginia 22161. In ordering, it is recommended that the JPRS number, title, date and author, if applicable, of publication be cited.

Current JPRS publications are announced in Government Reports Announcements issued semi-monthly by the National Technical Information Service, and are listed in the Monthly Catalog of U.S. Government Publications issued by the Superintendent of Documents, U.S. Government Printing Office, Washington, D.C. 20402.

Correspondence pertaining to matters other than procurement may be addressed to Joint Publications Research Service, 1000 North Glebe Road, Arlington, Virginia 22201.

JAPAN REPORT
SCIENCE AND TECHNOLOGY

CONTENTS

AEROSPACE SCIENCES

Government Acts to Step Up Air Commuter, Helicopter Services
(AEROSPACE JAPAN, Feb 86) 1

BIOTECHNOLOGY

Factors in Large-Scale Culture of Plant Cells Outlined
(Teijiro Morimoto; BIO INDUSTRY, Feb 86) 7

CHEMICAL ENGINEERING

General Electric, Japan, Executive Discusses Engineering Plastics
(Hideo Sato Interview; KOGYO ZAIRYO, Oct 85) 16

COMPUTERS

Handwritten Chinese Character Recognition, Categorization Studied
(Kunio Sakai, Haruo Asada; KEISOKU TO SEIGYO, Nov 85) 29

Recent Progress of Sigma System Reported
(JECC NEWS, 1 Feb 86) 41

DEFENSE INDUSTRY

Possible Military Applications of Stratospheric Airship Discussed
(Junichi Kimura; et al.; BOEI GIJUTSU, Nov 85) 49

NUCLEAR DEVELOPMENT

Status of Laser Enrichment Technology Updated
(Yasushi Sakabe; PUROMETEUSU, Nov 85) 63

Interim Report on High Temperature Gas Reactor Development
(GENSHIRYOKU SANGYO SHIMBUN, 1 May 86) 70

/9987

AEROSPACE SCIENCES

GOVERNMENT ACTS TO STEP UP AIR COMMUTER, HELICOPTER SERVICES

Tokyo AEROSPACE JAPAN in Japanese Feb 86 pp 32-33

[Article: "New Standards on Air Commuter Service; Policy To Increase Use of Helicopters Decided"]

[Text] The Civil Aviation Bureau, Ministry of Transport, which had been studying increased air commuter service and conformity to the government's action program, prepared new standards and a utilization policy and announced them on 26 December [1985].

This announcement by the Civil Aviation Bureau comprises two features: new standards concerning commuter service and the intensified utilization of helicopters; it is in the nature of "deregulation a la japonais." Below is the summary of the notable aspects and main amendments.

1. New Standards on Air Commuter Service

The new standards on air commuter service (standards on the approval of conduct of passenger transportation between two points) may be generally divided into standards for airplanes (amendment of old standards) and standards for helicopters (newly prescribed) and their essentials are consolidated in Tables 1 and 2.

First, let us discuss commuter service using airplanes. The new standards prescribe that even where there is airline service, commuter service may be provided if no fear of the latter seriously affecting the former is involved. Judgement in this connection is rather difficult. For example, a commuter route between Chofu and Oshima is permissible even though there is airline service between Tokyo and Oshima. This is a problem with, say, the Tokyo-Yatsuo route, whereas, commuter companies can operate on the same competitive route.

Equipment used, a highlight of the amendment, has been drastically expanded from the past standard of up to 5.7 tons (equivalent to approximately 19 seats in terms of seating capacity) in maximum take-off weight to 60 seats at maximum. Theoretically by these standards YS-11 with 60 seats can be flown as a commuter plane. But analyzed in further detail, the necessary number of pilots is one business pilot for up to nine seats; one senior business pilot and one business copilot for a maximum take-off weight of up to 13.65 tons of aircraft; one airline transport pilot and one copilot for more than 13.65 tons. In terms of specific equipment, equipment with up to nine seats include Islander, equipment

of up to 13.65 tons include Short 330 (30 seats), Short 360 (36 seats), Brasilia (30 seats), CN-235 (39 seats) and Saab SF340 (35 seats) and equipment of more than 13.65 tons include DASH8 (36 seats), DASH7 (50 seats), ATR42 (45 seats) and Fokker 50 (50 seats). As for maintenance crew, the maintenance of equipment of up to 15 tons in maximum take-off weight is the work of 2d-class aircraft mechanics while that of equipment of more than 15 tons is the work of 1st class aircraft mechanics. DASH7, ART42 and Fokker 50 are commuter planes of more than 15 tons. The recent amendment is unique as far as cabin crew members are concerned. It set forth the following details: No cabin crew is necessary if the number of seats does not exceed 19. Even if the number of seats is 20 to 30, none is necessary if the number of passengers who actually board does not exceed 19 but one is necessary if the number of passengers exceeds 19. One is unconditionally necessary if the number of seats is 31 to 50 and two are necessary if the number of seats exceeds 50.

The new standards have opened the Japanese market to nearly all commuter planes, making all trading companies happy (particularly, those with larger commuter planes). As standards for aviation, they are, if anything, laxer than U.S. counterparts as far as pilots, etc. are concerned. (The United States lacks the category of senior business pilot.)

The standards for commuter service using helicopters have been newly set to replace the temporary standards having been formed to meet needs in the Taikuba Scientific Exposition. What is most remarkable about these standards is the relaxation of regulation on the flying formula; the rules on special visual flight requiring ground visibility of 3 km or more have been relaxed to 1.5 km. This directly contributes to the improvement of the operation rates of flight personnel. Further, one may mention the fact that navigation by the night visual flight formula has become possible, though conditionally, for helicopters as well as for airplanes, the fact that the flight experience of captains has been cut from 2,000 hours to 1,500 hours and the fact that the standards for heliports used for the take-off and landing of helicopters have been relaxed.

It is expected that the setting of these new standards will bring closer to realization the Narita-Haneda and Narita-Tokyo Heliport heli-commuter services for which preparations are now being made.

2. Measures To Further Utilize Helicopters

These are measures aimed at the further utilization of helicopters by relaxing current regulations on the use of helicopters to a minimum within the limits of safety and the protection of environment. The measures have not only relaxed the standards for providing heliports to the U.S. level and relaxed accordingly the standards for approving extra take-off/landing grounds (temporary heliports) but also revised the standards for helicopter operation.

Especially, the regulation of such matters as the length of approaches to heliports and extra take-off/landing grounds and the surface gradients of these approaches has been drastically relaxed. In addition, it has become possible for these facilities to be operated more flexibly than ever by such wording as ".... as designated by the Minister of Transport."

Furthermore, the new navigation standards for helicopters allow for the shortening of flying routes and give considerable latitude to helicopter operation to the major airports of Narita, Haneda and Osaka in order to step up scheduled passenger transportation by helicopters.

The Civil Aviation Bureau is hopeful that these new standards will stimulate the construction of heliports and the operation of helicopters and thus further the use of helicopters and enable them to be imported in increasing numbers.

Table 1. Standards on Approval of Conduct of Airline Passenger Transportation Between Two Points

1. Transport section	There must be no fear of seriously affecting the maintenance of airline transport service.
2. Enterpriser	Person with stabilized business foundation and technical ability.
3. Airplane	(1) Maximum number of seats: less than 60, (2) Rules concerning equipment requirements: omitted. (They are as prescribed in Aviation Law Enforcement Regulations.) (Before amendment, multiengine planes with maximum take-off weight of 5,700 kg)
4. Flying formula	Principle: IFR, VFR may be used except for following: (1) On-top flight, (2) Night flight in such air space as congested air space and air space where position confirmation by ground lights, etc. is impossible. (3) Flight beyond 20,000 ft. (4) Flight under meteorological conditions prescribed by detailed execution rules.
5. Pilot (captain)	(1) For airplanes with maximum take-off of up to 13,650 kg ① Senior business pilot, ② Flight experience of at least 1,500 hours. ③ Must have company permit. (2) For airplanes with maximum take-off weight of more than 13,650 kg ① Pilot for airline transport. ② Flight experience of at least 2,000 hours. ③ Must have Civil Aviation Bureau's permit.

- 6. Cabin crew There must be one cabin crew member if the number of passenger seats does not exceed 30 and the number of passengers exceeds 19 or if the number of passenger seats exceeds 30 but does not exceed 50. There must be two cabin crew members if this number exceeds 50.
- 7. Report on transport results Rules: omitted. (It has become unnecessary to report every month and every business year.)
- 8. Temporary or Permanent stop of business This has only to be reported to Civil Aviation Bureau. (Before amendment, it had to be approved by Civil Aviation Bureau.)

Table 2. New Standards on Approval of Conduct of Helicopter Passenger Transportation Between Two Points

-
- 1. Enterpriser An unscheduled air transport enterpriser desiring to start helicopter-air transportation between two points must be a person recognized to have sufficient business foundation stability and technical ability to carry out this transport business infallibly.
 - 2. Equipment to be used Rotary wing aircraft transportation TA class (Equipment that can safely continue to fly even if one of the two engines fails.)
 - 3. Flying formula It must be VFR (visual flight regulation) formula. Special visual flight is approved for ground visibility of 1.5 km or over. (By Tsukuba Expo standards, special visual flight was available for 3 km or over.)
 - 4. Pilot In principle, there must be two pilots. However, one is sufficient if the number of passenger seats does not exceed nine. Must be qualified as captain. (1) Business pilot with flying experience of 1,500 hours or over. Must have company permit. (By Tsukuba Expo standards, business pilot with flying experience of 2,000 hours or over.)
 - 5. Cabin crew There must be a cabin crew if the number of passengers exceeds 19
 - 6. Temporary or permanent halt of business The temporary or permanent halt of business must be reported without delay.
 - 7. Place of take-off and landing No rules. (In accordance with permission standards in proviso of Article 79, Aviation Law.)

- | | |
|--------------------------------|--|
| 8. Periodic screening | (1) There must be a company screening system and a pilot in charge of inspection and captains must be screened once a year by pilot in charge of inspection. (2) Pilot in charge of inspection must be qualified once a year by Civil Aviation Bureau. (By Tsukuba Expo standards, company rules concerning training and screening were prescribed.) |
| 9. Report on transport results | No rules. (By Tsukuba Expo standards, monthly reporting to Civil Aviation Bureau was required.) |

Table 3. On Measures To Increase Utilization of Helicopters

- | | |
|---|---|
| 1. Standards on Installation of Heliports | [Relaxed to U.S. level] |
| ① Length of approach | Always 1,000 m. For a rooftop heliport, length of less than 1,000 m and designated by Minister of Transport. (Before amendment, 1,000 ~ 2,000 m) |
| ② Gradient of approach surface | Always 1/8 (For scheduled passenger transport, as prescribed separately). For a rooftop heliport, gradient of at least 1/8 and designated by Minister of Transport. |
| ③ Gradient of shift surface | Always 1/2. (Before amendment, always 1/4) |
| ④ Length of radius of horizontal surface | Always 200 m. For a rooftop heliport, length of less than 200-m and designated by Minister of Transport. (Before amendment, 400 ~ 800 m) |
| ⑤ Approach take-off path | Allowed approach and take-off directions of up to 90° (Before amendment, straightline, as a principle) |
| ⑥ Forced landing area | No forced landing area is provided for a heliport use by helicopters of types capable of vertical take-off. |
| 2. Standards for Approval of Extra Take-off/Landing Grounds | [Relaxed in general accordance with standards on installation of heliports] |
| ① Length of approach | Less than 1,000-m may be used. (Before amendment, 1,000-m) |
| ② Gradient of approach surface | 1/8 (For scheduled passenger transport, as prescribed separately). (Before amendment, 1/10) |

- ③ Length of radius of horizontal surface No need to be set.
- ④ Landing zone Length and width: length of fuselage x 1.2 (For scheduled passenger transport, as prescribed separately.)
- ⑤ (Procedure of applying for approval No drawings need be appended if no conditions have changed since previous approval. Also, photographs and compendium on conduct of navigation are unnecessary.
- ⑥ Period of approval 15 days, as a principle and 1 year at maximum. (Before amendment, 15 days, as a principle, and 3 months at maximum)
3. Navigation Standards for Helicopters
- ① Flying route Short-cut routes may be set for high-performance twin-engine helicopters used for scheduled passenger transport. (For others, flying routes at levels below minimum safety altitude may be used freely.)
- ② Night flight IFR: free. VFR: permissible under certain conditions (including ability to ascertain position by ground lights, etc.).
- ③ Ground visibility (special VFR) 1.5-km or over. (Before amendment, 3-km or over for scheduled passenger transport)
- ④ Use of existing airports Use of Narita, Haneda, and Osaka Airports is disapproved, as a principle. (Possibilities of use of these airports for scheduled passenger transport are being studied). Other airports are made available, whenever possible.

20,108/7051
CSO: 4306/2550

BIOTECHNOLOGY

FACTORS IN LARGE-SCALE CULTURE OF PLANT CELLS OUTLINED

Tokyo BIO INDUSTRY in Japanese Feb 86 pp 67-72

[Article by Teijiro Morimoto, acting director of Bionics Laboratory of Mitsui Petrochemical Industries Ltd.]

[Text] It is shown in the culture of plant cells that the propagation of cells and production of secondary metabolic products are greatly influenced by such physical factors as culture temperature, coefficient of oxygen transfer capacity, concentration of dissolved oxygen, and speed and method of stirring. A method of optimizing these factors to establish large-scale culture technology is introduced, along with several large culture tanks.

1. Introduction

We put secondary metabolic products of plants to use in such things as medicines, seasonings, dyes and sweeteners. Because these are at present obtained from plants, whether grown or gathered, they are subject to the problems of seasonal and regional restrictions and nonuniformity of quality and content. Moreover, in recent years the plants which serve as raw materials have become less plentiful each year, and some are just short of extinction. The issue of new resources is becoming a problem.

In an effort to solve, in one stroke, the problems involved in natural plants, there has been active research on putting vigorous culture cells into suspension in a tank to cultivate plant tissues from individual cells which produce large volumes of secondary metabolic products. But most of this research is still on an experimental scale; the only cases of results on an industrial scale are my murasaki [gromwell, a plant of the genus *Lithospermum*] cell cultures in a 0.75 m³ tank and ginseng cell cultures in a 2 m³ tank by Nitto Electric Industrial Co. Although the plant tissue culture is an attractive method in terms of production of secondary metabolic products, industrial use of the method has been delayed. One reason for the delay is that results obtained in the laboratory often cannot be reproduced using large-scale equipment. Plant culture cells are large-- 20 to 60 microns-- and soft. And because large clumps are formed when large numbers of cells are brought together, they are sensitive to environmental changes and to stress. When temperature controls, oxygen supply and stirring method differ from those in the laboratory and large culture equipment with completely different shapes

are used, it is no wonder that the same results cannot be obtained. At present there is not enough industrial research to understand and solve these problems. But in order to increase the importance and improve the future promise of plant tissue cultures, it will be necessary for research to develop in this field.

In this paper, I will present a number of fundamental items considered in the course of establishing a method for shikonin, and related research results. I will also discuss, for reference purposes, the future development of large-scale plant cell culture technology.

2. Influence of culture temperature

Propagation of plant cells and production of secondary metabolic products are greatly affected by temperature; suitable temperatures are generally between 20° and 30°C. For example, Ogotuga et al have reported that caffeine production by tea callus is highest at 26°C.¹⁾ Minakami reported culturing murasaki callus in the range from 10° to 30°C, with both propagation and shikonin production greatest at 20°C. Both were suppressed at low temperatures, while at 30° there was little suppression of propagation but almost no shikonin production.²⁾ When I cultured murasaki cells in a liquid medium for two weeks in the range from 20° to 30°C, the yields of cells and shikonin were as shown in figure 1.

Figure 1 Influence of temperature on murasaki cell cultures

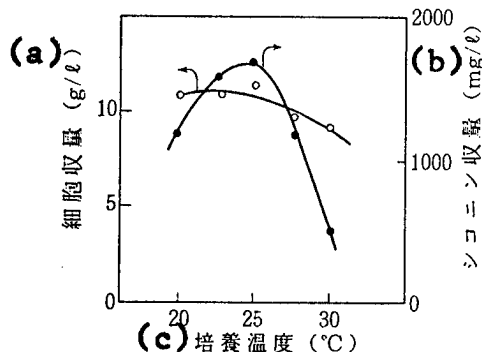

- (a) Cell yield
- (b) Shikonin yield
- (c) Culture temperature

Within this temperature range, the cell yield declines somewhat beyond 25°C, but no great change was noticed. The shikonin yield, on the other hand, is greatest at 25°C, and drops off rapidly above or below that temperature. Shikonin production is particularly curtailed at temperatures above 25°C.

This situation closely resembles Minakami's results, cited above; this indicates there is almost no difference between solid and liquid cultures of murasaki cells in regard to the effect of changes of temperature.

From research on propagation of tobacco cells, Shono concluded that variation of cell propagation resulting from culture temperature is based on variation in metabolism of endogenous hormones, especially cytokinin.³⁾ The influence of temperature on propagation of murasaki cells may come through the same mechanism. The influence of temperature on the secondary metabolic product shikonin, on the other hand, is thought to result from the activity of enzymes involved in its synthesis.

Because the production of secondary metabolic products in plant cell cultures is thus sensitive to changes in culture temperature, it is necessary to accurately control culture temperature to obtain secondary metabolic products efficiently. In laboratory research, it is possible to control culture temperature accurately by using a thermostatic tank. But in large culture tanks where temperature is controlled by heating or cooling with thermal catalysts, it is necessary to devise methods for accurate determination of temperatures within the tank, and to control the temperature evenly, without hot spots.

3. Supply of oxygen

Culture cells propagate and produce secondary metabolic products by incorporating oxygen dissolved in the liquid culture medium. It is thus important to carefully supply adequate amounts of oxygen in the culture medium. The controlling factors are the coefficient of oxygen transfer capacity k_{La} and the concentration of dissolved oxygen C . The relationship between these two values in the presence of cells is shown in the formula:

$$dc/dt = k_{La}(C^* - C) - K_r \cdot M$$

where C^* is the saturation value of dissolved oxygen concentration, K_r is the relative absorption speed of the cells, M is the concentration of cells, and t is time. In actual measurements, however, it is difficult to obtain accurate values in the presence of cells, so K_r and M are sometimes left out of the equation.⁴⁾

I have investigated the relationship between k_{La} and the propagation of cells in cultures of murasaki cells. The results indicated that when k_{La} is less than 10hr^{-1} , cells propagate in proportion to k_{La} , but above 10hr^{-1} the rate of propagation is steady. Kato obtained the same results in his investigation of the relationship between k_{La} and propagation of tobacco cells.⁴⁾ The production of secondary metabolic products is also influenced by k_{La} . As shown in figure 2, in a culture of murasaki cells the production of shikonin increases in direct proportion to k_{La} when k_{La} is less than 10hr^{-1} , and is greatest when k_{La} is between 10 and 15hr^{-1} .

Figure 2 k_{La} and Shikonin Yield

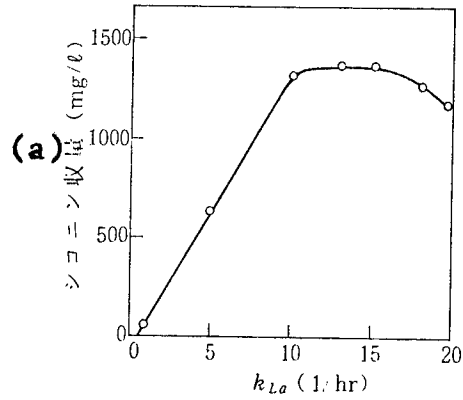

(a) Shikonin yield

The effect of concentration of dissolved oxygen in murasaki cell cultures is shown in figure 3. Cell propagation levels off after peaking at a dissolved oxygen concentration of 6 ppm. The production of the secondary metabolic product shikonin is influenced by the concentration of dissolved oxygen even more greatly than cell propagation is; shikonin production is greatest at concentrations of 5 to 8 ppm. Shikonin production drops off sharply with concentrations outside that range, so the concentration of dissolved oxygen must be strictly controlled. Fortunately, both propagation of murasaki cells and production of shikonin are greatest when the concentration of dissolved oxygen is close to 6 ppm, so shikonin productivity can be maximized by controlling that value.

Figure 3 The effect of concentration of dissolved oxygen in murasaki cell cultures

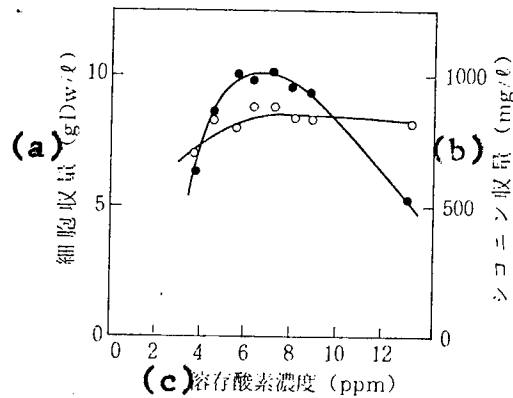

- (a) Cell yield
- (b) Shikonin yield
- (c) Dissolved oxygen concentration

In large-scale cultures of plant cells, necessary oxygen is normally supplied by blowing a gas containing oxygen into the culture tank. There has been doubt as to whether it is better, at such times, to let a gas with a high concentration of oxygen slowly permeate the culture, or to blow in a gas with a low oxygen content. Using cultures of murasaki cells, gases with oxygen concentrations ranging from 21 percent (air) to 90 percent were blown in, with the flow speed varied to maintain dissolved oxygen concentration at the optimal 6 ppm. Cell yields and shikonin production in 14-day cultures are shown in figure 4.

Figure 4 The Effect of Ventilation Rate

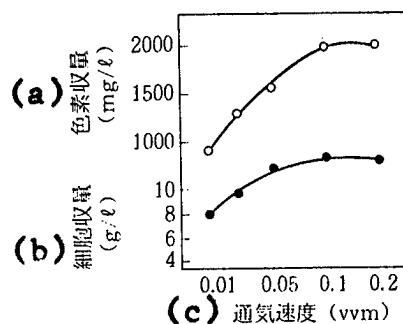

- (a) Pigment yield
- (b) Cell yield
- (c) Ventilation rate

Both cell yield and shikonin production are greater when the ventilation rate is higher; that is, when a gas with a low concentration of oxygen is infiltrated. Within the scope of this experiment, it was best to ventilate with air. Compared with the use of gas with an oxygen concentration of 90 percent, the cell yield is 1.5 times as great when air is used, and shikonin production is twice as high. The influence of this can be called quite great.

4. Influence of Stirring

Plant cells themselves are large, and they tend to clump together when propagating. They are sensitive to stress, and often subject to physical damage. For example, Tanaka has reported an experiment in back-and-forth shaking of a flask containing a culture of *Cudrania tricuspidata* (harikuwa) cells. The faster the flask was shaken, the fewer large-sized cell clumps there were, and the more small-sized clumps. But almost no living cells were found in the small clumps; there were only dead cell fragments.⁵⁾ It is thus a major task to keep the plant cells as free from stress as possible in the culture tank, while stirring them to maintain an even distribution and renew the liquid medium on the surface of the cell to allow absorption of the necessary oxygen and nutrients.

No method has been developed yet to quantitatively measure the degree of physical effect of stress on plant cells in a culture. Tanaka has tried to get a quantitative understanding of the effect of stress on cells, although indirectly, using coefficient k , which is the extent of solid particles dissolved in the liquid medium of a general mixing tank.⁵⁾ That is, he used beta-naphthol particles which have about the same specific gravity as plant cells, poor solubility in water, and about the same size as clumps of plant cells, and he sought values of k for various mixing conditions. Then he cultured harikuwa cells for 15 days using the same conditions to determine the relationship between k and cell propagation. As shown in figure 5, the results were that the volume of cells decreased as k increased, dropping off particularly when k exceeded 4.4×10^3 cm/sec. That fact suggests that the k value shows the extent of physical effect on cells, and that cell propagation is controlled by the strength of physical influences on the cells.

Figure 5 Relationship Between k Value and Propagation of Harikuwa cells

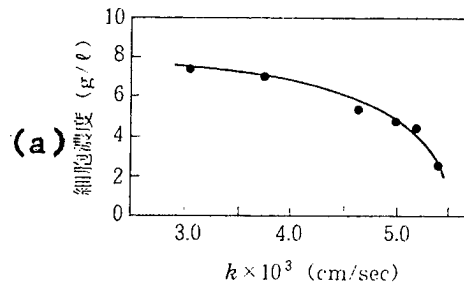

(a) Cell concentration

As an example of the relationship between the physical effect on cells and the production of secondary metabolic products, a culture of murasaki cells was done using a ventilation culture tank; figure 6 shows the relationship between mixing speed and shikonin yield. The mixing tool used was the four-blade screw type.

Figure 6 Influence of mixing speed on shikonin yield

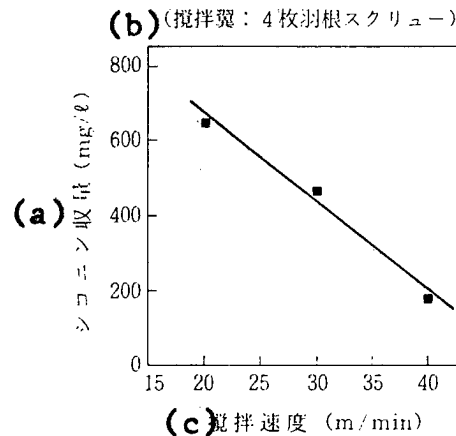

(a) Shikonin yield
 (b) Mixer: four-blade screw
 (c) Mixing speed

Within the scope of this experiment, there was a straight-line correlation between shikonin yield and mixer speed; the slower the mixer speed, the greater the shikonin yield. The slope of the line is quite steep; mixer speed has a controlling influence on shikonin production. Mixer speed exerts a physical effect on cells, such as the shearing stress mentioned previously, and the effect on production of secondary metabolic products is far greater even than the effect on cell propagation. It has a grave effect. Together with the culture equipment discussed in the next paragraph, mixing is one of the most serious issues in carrying out large-scale cultures.

5. Large-scale Culture Equipment

Plant cell cultures are often regarded as being the same as microbe cultures and carried out in the same way. But as I have already said, the cells are larger and form into clumps, so they are more easily affected by ventilation and mixing than microorganisms. It is thus necessary to think of plant cell cultures apart from microbe cultures and consider culture equipment based on the characteristics of plant cells. A number of studies have been made with the ventilation mixing tanks and airlift culture tanks widely used with microbe cultures, but results have not been consistent, and it is hard to say which type is superior.

Wagner et al used four types of equipment including ventilation mixing tanks and airlift culture tanks with yaeyama-aoki cells to study cell propagation and production of the secondary metabolic product anthraquinone.⁷⁾ The results were that in ventilation mixing tanks there was somewhat less cell propagation in the area of the mixer blade, and anthraquinone production was greatly suppressed. But in airlift culture tanks fitted with draft tubes, there was little shearing stress on cells and the supply of oxygen was adequate; both cell propagation and production of anthraquinone were good, and this equipment was declared superior for plant cell cultures. Wilson, on the other hand, has pointed out that there is generally no problem with airlift culture tanks if the cell concentration is less than 2 percent, but higher concentrations are not desirable because there is inadequate mixing within the tank.⁸⁾

Tanaka tested the characteristics of four types of tanks, including ventilation mixing tanks and airlift culture tanks, with a high-density culture of harikuwa cells. The result was that when an airlift culture tank with draft tube attached was used with a cell concentration of 1.1 percent, k_{La} was unacceptably low-- half of that when no cells are present. On the other hand, in a ventilation mixing tank with a variable paddle-type mixer blade, adequate uniformity and air bubble dispersion was maintained even with cell concentrations above 2 percent; there was only a very slight decrease in k_{La} , and he concluded that this is the best culture equipment for plant cells.⁵⁾

I cultured murasaki cells using a ventilation mixer tank, an airlift culture tank with draft tube and a rotary ventilation tank. The rotary ventilation tank is a horizontal, cylindrical culture tank with ventilation and exhaust tubes mounted internally; mixing is accomplished by rotating the culture tank itself.⁹⁾ As the culture process went forward in the airlift culture tank

with draft tube and the concentration of cells increased, distribution within the tank became uneven and cells were expelled, so it was not possible to collect accurate data. The occurrence of this sort of operational trouble may be a fatal defect. Figure 7 shows shikonin production in relation to the mixing speed (rotation speed for the rotary tank) in ventilation mixing tanks fitted with four-blade screw and variable-paddle mixer blades, and the rotary ventilation tank. Of the ventilator mixing tanks, the variable-paddle mixer blade type caused less shearing of cells than the screw type, as Tanaka pointed out, and thus allowed a higher shikonin yield. the rotary mixing tank showed a straight-line relationship between shikonin yield and mixing speed (tank rotation): the slower the mixing speed, the greater the yield. Shikonin yield in the rotary tank was the same as in the ventilation mixing tanks fitted with variable-paddle mixer blade. And because the inner surface of such a tank is continuously washed by the culture liquid, cells do not adhere to the cell wall, and stable, long-term operation is possible. The rotary tank is considered superior as a device for large-scale culture of plant tells.

Figure 7 Mixing method and shikonin yield

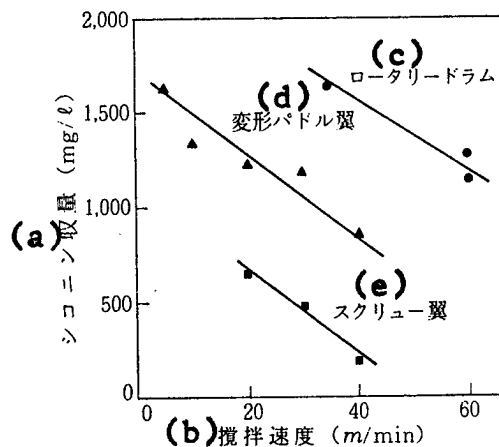

- (a) Shikonin yield
- (b) Mixing speed
- (c) Rotary drum
- (d) Variable-paddle blade
- (e) Screw blade

6. Conclusion

I have stated a number of fundamental items that should be kept in mind in establishing technology for large-scale culture of plant cells. Even though the importance of plant cell cultures and their industrial value is recognized and research has been done on some aspects, industrial research to establish large-scale culture technology has not gone beyond the beginning stage. Large, soft, easily-damaged plant cells form clumps as they propagate; in

order to explicate that circumstance and relate it to large-scale culture technology, it is necessary to establish a new field of research-- plant cell culture engineering-- which is independent of the earlier fermentation engineering. That will be of great engineering value, not just because of the production of secondary metabolic products, but because of numerous research results in regard to plant tissue cultures. Although the content of this paper is merely superficial and descriptive, I would be happy to think it was a step in the progress of research in this field.

BIBLIOGRAPHY

- 1) D.A.B. Ogutuga and D.H. Northcote: "J. Exptl. Bot.," 21, 258 (1970)
- 2) H. Minakami: Kyoto University dissertation
- 3) K. Syono and T. Furuya: "Plant Cell Physiol.," 12, 61 (1971)
- 4) H. Tanaka: HAKKO KOGAKU, 63, 245 (1985)
- 5) A. Kato: HAKKO KOGAKU, 60, 105 (1982)
- 6) H. Tanaka: "Bioatechnol. Bioeng.," 23, 1203 (1981)
- 7) F. Wagner and H Vogelmann: "Plant Tissue Culture and Its Biotechnological Application," p 245, Springer-Verlag, Heidelberg (1976)
- 8) G. Wilson: "Frontiers of Plant Tissue Culture 1978," (Thorpe, T.A.), p 169, Calgarg (1978)
- 9) Mitsui Petrochemical Industries Ltd.: Special publication 58-134989 [1983]

9601

CSO:4306/1159

CHEMICAL ENGINEERING

GENERAL ELECTRIC, JAPAN, EXECUTIVE DISCUSSES ENGINEERING PLASTICS

Tokyo KOGYO ZAIRYO in Japanese Oct 85 pp 1-13

[Interview with Hideo Sato, president of General Electric (USA) Plastics, Japan, by Akira Suzuki, editor; date and place not specified]

[Excerpts] Whereas the engineering plastics industry has steadily been growing in Japan, severe competition is taking place in the domestic engineering plastics market joined by aggressive foreign makers such as EPL, Du Pont, and ICI. For the 18th part of the "High-Level Interview on Most-Advanced Industrial Material" series, Akira Suzuki, editor, visited Hideo Sato, president [title as published] of General Electric Technical Japan Branch, Plastics Business Division, Services Co., Inc., to interview him chiefly on GE's strategy for engineering plastics marketing.

Definition of "Engineering Plastics" Still Uncertain

Suzuki: I guess what the readers of the KOGYO ZAIRYO most wish Mr Sato to talk about are the advantages and disadvantages of Japanese-made industrial materials. Today, your talk will center on engineering plastics. As president of General Electric (USA) Plastics Japan, you may not be in a position to freely talk about every thing as asked, but I would be obliged if you would generally discuss Japanese-made engineering plastics from an objective point of view.

Sato: To comply with such a request is rather difficult. I feel it is appropriate to start our discussion by considering what engineering plastics is. When GE first brought polyphenylene-oxide (PPO) into Japan, Japanese industry was not yet in a state which enabled PPO to be processed for molding, that is, judged from an overall standpoint with such factors as mechanical properties of the resin, the resin molding technology and the ability to design molds taken into consideration. It was not possible to have PPO molded in Japan at that time (around 1966) when acrylonitrile-butadiene-styrene (ABS) resin was in the limelight. At that time, Japan had just acquired technology for molding general-purpose ABS resin. It was around that time that they started using the term "engineering plastics." There was no established definition of engineering plastics. Even today, I occasionally feel it necessary to determine what engineering plastics is, but it is not yet entirely clear to me.

Plastics products include household articles, but engineering plastics is somewhat different from plastics used to produce household goods. It is used as industrial material. It does not follow, however, that any plastics, which may be vinyl chloride resin or ABS, usable as industrial material, are engineering plastics. Can we then say that resin which can replace iron is engineering plastics? I cannot definitely say "Yes" or "No."

Recently, a derivative term "general-purpose engineering plastics" came into use. I wonder if the introduction of the term "general-purpose engineering plastics" suggests that, as the sales of certain industrial-use plastics increase, such plastics come to be less frequently referred to as engineering plastics. It is difficult to determine whether such understanding is appropriate. Rather than making things difficult, I feel I may roughly define engineering plastics as plastics which are used for functional parts, can replace metal depending on the case, and require utmost care as to molding and specification design.

This definition of engineering plastics agrees with the history of engineering plastics. Again, it was around 1966 that GE brought PPO, that is, modified PPO trade-named "Noryl" into Japan for the first time. At that time, Noryl was almost ignored. The first disadvantage pointed out of Noryl was the difficulty involved in molding it. The temperature range allowable for molding it was very narrow. Even if it was molded into products, the products easily broke unless they were very well designed. Furthermore, it was, after all, expensive. It did have many advantages, such as high thermal resistance and fireproofness, but these were outweighed by the disadvantage--difficulty in molding.

After the disadvantage was overcome, Noryl started growing rapidly in the market. Now, with nearly 20 years having elapsed since we started promoting Noryl from scratch in Japan, its sales come close to ¥40 billion a year. Based on the present status, I may say that Noryl is an example of a great success we have accomplished in Japan.

Engineering Plastics Makers Are Not Mere Suppliers; They Are Customers' Partners

Sato: Reviewing past development, I feel that successfully promoting engineering plastics requires the makers to work hand in hand with the users through the designing stage, the molding process, and the after-sale follow-up to confirm the long-range safety of the products. I think a characteristic of industrial material, called engineering plastics, is that it requires its makers to be capable of extending extensive care, including both before-sale and after-sale care to the users.

Suzuki: That is what Matsumura, managing director of Mitsubishi Gas Chemical Company, also stressed when I interviewed him for the 16th part of this "high-level interview" series.

Sato: Is that so? Well, I can understand why he would. Mitsubishi Gas Chemical and my company resemble each other in our manner of doing business. Take polycarbonate, for example. Teijin Ltd., another company in the same line of business, is rather good at sundries, for example, such small items as eyedroppers and combs, and larger goods like helmets. It is because Mr Hattori of Teijin Ltd., maintains a close network between the company and many small- and medium-sized enterprises, and the network enables the company to efficiently promote its products while taking good care of the users.

The approach used by Mitsubishi Gas Chemical as well as our company is different from that used by Teijin Ltd. In our approach, which may appear somewhat unrefined, we tend to develop everything needed. To produce small parts, for example, we tend to originally design both the parts and the molds to be used.

I guess what Mr Matsumura meant is almost identical with what I recognize.

Suzuki: Of the development activity related to the marketing of your products, technical services are undertaken by EPL (a joint venture between General Electric (USA) Plastics Japan and the Nagase & Co., Ltd.), aren't they?

Sato: That's right. At the time we became the first to promote Noryl in Japan, we sent four people from Nagase, who are now with EPL, to the United States for training. After returning from the United States, they were assigned to be in charge of technical services. Since Nagase is a trading firm, we had no worry at all about its ability as far as sales were concerned. The term "technical service," however, even though everybody knows it today, was still relatively new to many people at that time. Anyway, under such circumstances, we started promotion, stressing technical services.

Now, let me outline our worldwide technical service system. Our technical service center is named the Plastics Technology Center. It belongs to our head office, and is located in Massachusetts. It is designed to serve customers. No research on plastic monomers or polymers is conducted there. It is used exclusively for the development of application technologies. People working there to develop application technologies keep in mind how various parts are to be designed and what plastic materials are to be used for different parts. Our worldwide technical service network includes 14 other technical service stations located in principal cities of the world.

Suzuki: You have one in Japan, too, haven't you?

Sato: Yes, one of them is located in Gotenba. The rest comprise those located in Atlanta, Detroit, Los Angeles, Selkirk and Mount Vernon of the United States, and those located in Toronto (Canada), Bergen-op-Zoom (Holland), Leslie (UK), Evreux (France), (Russelsheim) (W. Germany), Melbourne (Australia), and Milan (Italy). What I want to say is that we do not like to be called mere resin suppliers. We wish our customers to regard us as their partners. We welcome customers coming to us for consultation. We

will be pleased if our engineers and our machines can assist them in solving their problems. While working with customers, we will be able to introduce various resins which are not limited to those produced and sold by us to them. Often, things really develop that way in our application technology laboratory in Gotenba. Doing so is not our purpose, but there are cases in which we are led to do so while assisting customers in various aspects of their work.

So far, many people have come to the application technology laboratory in Gotenba, though I cannot mention their names. There were instances in which customers brought us their products, we disassembled and redesigned them, and improved manufacturing processes were suggested to the customers. Depending on the case and product, manufacturing process improvement we suggest to customers results in a reduction of ¥2,000 to ¥3,000 in unit manufacturing cost. These services are included in the functions of the application technology laboratory.

I consider that the customers' trust we have acquired by serving them in this way constitutes an important asset of our company. It may perhaps be said that such a way of doing business is peculiar to GE.

Differences Between Japanese and American Strategies for Engineering Plastic Marketing Are Lessening

Suzuki: You mentioned that, when GE brought its Noryl into Japan for the first time, the conditions in Japan as to resin molding technology, etc., were not yet ripe enough to enable immediate successful marketing of Noryl. I assume that the know-how of the processing of such a resin had already been established to some extent in the United States at that time, hadn't it?

Sato: You are right. But, even with regard to the ABS resin, the first engineering plastic introduced in Japan, people who have been in the resin business for many years will remember that processing was not easy in the early days. It does not necessarily mean that the molding technology level was much too low at that time. Rather, it simply means that molding machines suitable for application to the ABS resin were not in use at that time, and that the industry was not yet experienced in handling a resin with such a high heat distortion temperature (HDT) as that of the ABS resin. In the molding industry of today, no firm engaged in molding will find ABS molding difficult. It was certainly difficult, however, in the early days. Similarly, when Noryl was first brought into Japan, it was very difficult to mold the resin. Now, we are selling, among others, a resin trade-named "Ultem". The HDT of the Ultem is about 180°C and it is not easy to mold the resin. In the course of time, however, the molding technique will advance to make the molding of the Ultem no problem.

Polybutylene terephthalate (PBT) also went through a similar process. When it was introduced, its HDT was higher than those of other resins so that difficulty was involved in molding it. Now, no specialized firm will find PBT molding difficult.

Suzuki: I consider that, in the market for molded products, Japanese customers are much more mindful of details with regard to their requirements than American customers. When you review the development of engineering plastics in that way, I wonder, therefore, if there were cases in which molding techniques, developed in the United States, required some modification or improvement before being put in use in Japan to meet the requirements of Japanese customers.

Sato: There were many such cases. Speaking of the Japanese customers' mindfulness of details, they are generally very strict about even the shapes of pellets. In the United States, they are not as strict about such details. They do not complain even if pellets have fins or include irregularly shaped ones among them. This is only one example of a difference in attitude between the Japanese and U.S. customers. When engineering plastic pellets are produced at our company, we check them using metal detectors. The metal detectors used by us are of very high sensitivity so that they do not miss any pellets containing even the smallest amount of metal. In the checking system, the pellets detected by the metal detectors are automatically ejected as defective. The resin pellets having come through such strict checks can be used for such parts as coil bobbins for high-voltage applications. Such coil bobbins can be used where high voltages are used, in TV's and other machines without causing sparking or shortcircuiting. There are not many U.S. resin makers who use metal detectors with sensitivity comparable to that of those used by us. In Japan, such high-sensitivity metal detectors are indispensable. Furthermore, with regard to other factors such as the fluidity, heat resistance and fireproofness, engineering plastics produced in Japan is very stable. It is because the Japanese customers strongly request that the properties of the resins they purchase be highly stable.

We occasionally examine U.S.-made engineering plastics. Based on this, we are of the opinion that the quality of U.S.-made engineering plastic is not as stable as that of the Japanese-made equivalent. We assume it is because, compared with Japanese customers, U.S. customers do not impose as severe requirements on the resin makers. Our view of the qualitative stability of the U.S.-made resin is not peculiar to us. It is shared by other resin makers.

Suzuki: Then, are there cases in which, when know-how developed in Japan to meet requirements of the Japanese customers who care about details, is introduced in the United States, the U.S. makers reject the Japanese know-how saying it is not necessary to adhere to such details.

Sato: Well, the recent trend is the opposite from what you may expect. Canon Inc. is expanding into France. Toshiba Corp., Hitachi Ltd., and Sony Corp. are all advancing into the United States. Toyota Motor Corp. and Nissan Motor Co. are also going to the United States. Even if our customers go abroad, we have to prepare the specifications of resins needed by them, such as Noryl and Lexan. For customers engaged in production in the United States, for example, we provide GE with the specifications of resins needed by the customers so as not to inconvenience them in the United States.

When Japanese resin users go abroad, and purchase resins there, they demand quality comparable to that of the resins they use in Japan. When our customers start overseas production, therefore, whether in Europe, the United States, Australia, or Canada, we provide, as required, appropriate overseas affiliates of our with the specifications of the resins to be delivered to the customers. This is a kind of quality control. Such quality control is being advanced for a rapidly increasing number of Japanese customers engaged in overseas production.

Suzuki: I recently overheard that, when Japanese automakers start production in the United States, the Japanese resin producers selling resins to these automakers in Japan, transfer their service engineers in charge of the automakers to the United States, to let them take care of the resin requirements of the auto plants built in the United States by the Japanese automakers.

Sato: That's nothing new to us. We started using that type of approach 4 years ago. At present, two of our service engineers are stationed abroad; one in Mount Vernon, and the other in Detroit. They have been there for 4 years to deal with Japanese firms, so what you overheard is true. Japanese firms advancing into the United States feel that they and U.S. salesmen or marketing engineers do not quickly get tuned to each other in various negotiations. They say they find salesmen or sales engineers, who have a Japanese sense and can respond to their inquiries in the Japanese way, very handy. That's why we have resorted to such measures as keeping our representatives abroad for Japanese firms.

Suzuki: Doesn't it then happen that, when Japanese users, who are fastidious about their requirements, complain in the United States about the quality of U.S.-made resins in the same manner as they do in Japan, their complaints are rejected by the U.S. resin makers as being unrealistic?

Sato: Well, I may be going back to the original subject, but our share of the global engineering plastic market stands at around 24-25 percent based on the information obtained from various sources. We regard ourselves as being active and having been established as a worldwide resin supplier. Therefore, as far as we are concerned, we think we are prompt and flexible in dealing with complaints made by our customers.

Engineering Plastics Are Custom-Made

Suzuki: Sorry I am giving you question after question. By the way, I hope you will read the report of my interview with Matsumura, managing director of Mitsubishi Gas Chemical Co., when you have time. According to Mr Matsumura, Japanese plastic makers are, generally by far, smaller than their customers; for example, such automakers as Toyota Motor Corp. and Nissan Motor Co. Therefore, even then the inquiries given them by such large users are for resins which cannot easily be developed, they tend to work hard to develop the resins as requested, without putting up any resistance, hoping, eventually, to be given large-lot orders. He said that, in the United States and

Europe, plastic makers such as Du Pont, GE, and Bayer are on approximately even terms with their customers such as GM, Ford, and Chrysler in terms of corporate scale, so that U.S. plastic makers often assume a rather strong attitude toward their customers. For example, according to Mr Matsumura, there are cases in which they develop new plastics and ask their customers to find ways to make use of the new plastics. He said that the situation in Japan is different from that in the United States.

To our way of thinking, for example, we do not regard engineering plastics as something to be displayed at stores to attract buyers. To develop engineering plastics needed by customers, we closely consult with the customers on the parts to be developed, parts design, and the type of resin to be developed. When parts design is determined, we propose concrete properties of resin such as fluidity, rigidity, fireproofness and heat resistance which we consider suitable for the designed parts. We consider that supplying our customers with engineering plastics developed through such procedures is our role, as well as an advantage of our way of doing business. Therefore, as far as GE is concerned, there are no cases in which the plastic maker asks customers to accept its unilateral way of doing business.

We intend to further enhance our business in the field of custom-made engineering plastics. Noryl, in the first place, is custom-made resin. As you perhaps know, we can modify PPO differently (Noryl is modified PPO) to meet different requirements of different users. Such adjustability is an advantage of Noryl. For example, if a customer says that Noryl, to be molded by the company, required high fluidity, and that, to raise its fluidity, its rigidity may be sacrificed to some extent without affecting its heat resistance; then we can prepare Noryl to meet the needs of the specific customer. Adjustment in the stage of PPO modification enables Noryl to be given varied properties. It's a feature of Noryl.

If another customer requires Noryl's heat resistance be enhanced at the sacrifice of its fluidity, but without decreasing its rigidity, we can prepare such Noryl. Since we have long been dealing with Noryl in this manner, we are not reluctant to provide our customers with custom-made resins. We take it for granted that engineering plastics is custom-made to meet the needs of individual users.

Suzuki: I guess, while you work jointly with your customers to develop customized resins, some know-how will be generated. Do you possess such know-how jointly with the customers?

Sato: It depends on the case. When some know-how is developed while we are working jointly with a customer, the customer, in most cases, requests that the specific resin developed using such know-how be grade-numbered to prevent it from being sold to other customers for 2 to 3 years at the last. We comply with such a request, depending on the case. Since the know-how of engineering plastic modification is our property, however, there are not many cases in which we share know-how on plastics with customers. It is of course quite possible for us to do so if strongly requested by customers, depending on the case.

Suzuki: When the target properties of the resin to be produced for a customer are finalized between you and the customer, you determine the specifications, and produce the resin after having the specifications approved by the customer. The know-how you use to produce the resin according to the specifications becomes your property. Is my understanding right?

Sato: Right.

Suzuki: Speaking of the definition of engineering plastics again, I think the definition you gave certainly indicates one way of defining it. I myself consulted the second edition of McGraw-Hill's Dictionary of Scientific and Technical Terms published in Japanese by NIKKAN KOBYO SHIMBUN. I understand that no definition of engineering plastics has been established in the United States, either.

Sato: No, there is no established definition. That's true.

How Attractive Is the Japanese Market to Overseas Engineering Plastics Makers?

Suzuki: Now, let me change the subject. I understand that, recently, foreign resin makers including your firm, Du Pont, and ICI are stepping up their activities in the Japanese market or are planning on entering into the Japanese market. As we were discussing, there are many users fastidious about their requirements in the Japanese market. What is the attraction of the Japanese market that makes such foreign resin makers eager to advance into Japan?

Sato: Well, after all, Japan is the most industrially advanced nation in the Far East. Speaking of the attraction of the Japanese market, I think it's the growth rate. Japan's industrial production grows fastest. Any engineering plastic maker aiming to expand its business on an overall basis will think it necessary to advance into the country enjoying the highest rate of growth of industrial strength or industrial output.

Further, in this connection, I think, even though the term "multinational enterprise" is in use today, in a sense such a term is already obsolete. Comparatively speaking, the world is no longer as large as it was before. To be sure, when I was ordered to report to GE's head office in the United States while I was working for Union Carbide in Japan, that is, the company where I started my career in the resin business, I used to stay overnight in Hawaii en route from Haneda. I made another overnight stop at San Francisco en route from Hawaii before finally arriving at New York on the third day. It was, therefore, on the fourth day that I would report to the head office of the company. Since the trip from Japan to New York crosses the international date line, it took 4 days before I could start working in the head office after leaving Japan, putting aside the calculation of the net time taken. Needless to say, it took me the same amount of time to return to Japan. Today, if I am asked by phone to fly to New York, I am able to take a flight on the same day, arriving in New York in 13 hours. In this sense, the world is rapidly growing smaller and smaller. What is happening in

Europe can be immediately known in Japan through videotext information. At our company, we use a crossfile system which enables us to communicate with parties in the United States and Europe via a communications satellite.

With the global market narrowing like this, plastic users are advancing to areas all over the world, and material makers are also going out to various parts of the world. Under these circumstances, they cannot afford to expand into only a certain part of the worldwide market. For them, advancing into Japan or the Far East is only a step of their strategy aimed at spreading their foothold throughout the world. Isn't it imperative for them to adopt such a strategy?

It is true that many makers are coming to Japan. Du Pont is coming, ICI is coming, and Celanese, too.

On the other hand, many Japanese companies are going out. Toshiba Corp. is expanding into Britain and other European countries. It is advancing into Canada and the United States. It can go anywhere. Sony Corp. is spreading its operation on a global basis. I think such business globalization is a major trend of the present age. Neither the United States nor Europe is as far away from Japan as it used to be.

When Will Foreign Engineering Plastic Makers Start Production in Japan?

Suzuki: Certainly the advancement of telecommunications has greatly speeded up information exchanges. Even between the United States and Japan, information can be exchanged as easily and speedily as within either country. Still, physical distribution is required to cover the same physical distances as before. The physical distances over which materials and goods are to be transported have not been shortened. I hear that your company recently established GEM, a subsidiary, mainly for purposes of producing PPO and related products in Japan and supplying them to EPL which is a joint venture between your company and Nagase to enable the production of Noryl. If GE produces resins in the United States for sale in Japan, it has to ship the products over a distance of nearly 10,000 km. Information can instantaneously be transmitted between the two countries, for example, via a communications satellite, but physical products must travel the long distance.

Sato: You certainly have a point there. In planning our production strategy, we are required to consider all economic factors. We are willing to produce both monomers and polymers including PBT, polycarbonate and the Ultem in Japan in the future. Under the present circumstances, however, in which about 20 percent of the total production capacity of the Japanese polycarbonate makers, including Idemitsu, is not used if we construct our own polycarbonate production facilities in Japan, it will only confuse the market. Such an act will benefit neither ourselves nor users. As long as GE has huge production capacities both in the United States and in Europe, we consider, based on the present situation, that it is more advisable for us to have resins produced in the United States or Europe shipped to Japan. Long distances are involved, to be sure, but doing so, we think, is more economical when judged on an overall basis. I don't know what we will be doing next year, or the year after next, though.

Suzuki: It was reported on pages 11 and 12 of the 31 July 1985 issue of the U.S. chemical magazine CHEMICAL WEEK that GE was planning to increase its annual polycarbonate production capacity by 125 million pounds.

Sato: Yes, the company is going to build a large plant. New technology is going to be used for production at the plant, so that high-quality plastics will be produced there.

Suzuki: It is said that production in Japan is uneconomical at a production level below 15,000 tons per year. Therefore, depending on the expected sales volume, there can be cases in which shipping resins, produced at low costs at a large overseas plant, to Japan for sale there is more advisable, even if the long-distance shipping cost is taken into account, than starting the production of such resins in Japan. Right?

Sato: That's right. In planning the construction of a resin plant, it is necessary to take into account the funds needed to construct such a resin plant, say, with an annual production capacity of 15,000 tons, the interest on the funds, the depreciation, other relevant investments to be made, and various expenses. To determine which is better, producing resins in Japan or having resins shipped to Japan, the resin production cost calculated based on such factors should be compared with the cost of resins produced overseas and shipped to Japan. I think Ross Child's strategic plan is based on such consideration.

Elaborating on this subject, it is our company that holds the largest share of the polycarbonate market in the Far East, including China. In Japan, however, our market share stands at around 15 percent. How come our share in Japan is not as high? We, of course, would like to have a larger share, but a larger share does not mean greater profitability. In other words, a market share of 10 to 15 percent may be most appropriate for us as long as we stick to normal sales promotion.

If we start selling monomers in the future, however, I think we should try to increase our market share. The direction in which we should advance may change year by year. We have a plan to start polycarbonate production in Japan, but I'm sure we will not carry it out this year, under the current circumstances. Probably, we will not carry it out next year either. What about the year after next? It's a matter requiring later consideration.

Evaluation of Japanese-made Engineering Plastic Molding Machines in Worldwide Market

Suzuki: Now, I'd like to talk about the Japanese-made plastics molding machines. How are they, those for molding mainly engineering plastics, evaluated in the United States and Europe.

Sato: I think they are highly rated. Introducing a case we experienced ourselves, we are using a machine made by Toshiba Machine Company. By the way, it is not because I was once an executive member of a joint venture

between our company and Toshiba Machine Company. I think the Toshiba-made machine is less expensive and has higher performance than a certain German-made machine, though I refrain from mentioning the name of the German maker. The machine I am speaking of is not a molding machine, it is an extruder. It is also being used by GE in the United States for silicone extrusion. Its performance is rated highly in the U.S. plant, also. When it comes to servicing, however, the maker's service stations nearest our plants are still much too far away. The service network of Toshiba Machine is not yet so extensive as to enable its servicemen to be available at our plants on request by phone. Therefore, I regret to say, Toshiba-made machines are not convenient for us to use in the final analysis. I really regret to say this.

Suzuki: For the fifth part of this high-level interview series, I interviewed Mr Shima, president of Nissei Plastic Industrial. On that occasion, I learned that molding machine makers are striving to meet the needs of molding machine users. I am sure that they will produce good machines.

Sato: I refrain from mentioning the names of specific makers, but we are conducting joint research with many machine makers. For forming, for example, we are engaged in R&D work jointly with machine makers on blow molding machines, injection molding machines, etc.

Suzuki: I heard an interesting story from Mr Shima. He was speaking of parts for wristwatches. According to him, among the parts for wristwatches are very small plastic parts which require high precision. He said there are cases such as the following: When a user requiring such small precision plastic parts visits a plastic maker for negotiation, the plastic maker says: "OK, if we can develop the plastic that meets your requirements, how many tons of the plastic will you order from us?" The user then answers: "Well, we do not need tons of the plastic for such small parts. We will require scores of kilograms of the plastic." The plastic maker rejects the inquiry saying: "Developing a plastic for such a small-scale demand does not pay."

Sato: Among many plastic makers, there may be some which assume such an inflexible attitude. Excuse me, but, does your wristwatch have a calendar? (Sato leans over to look at the wristwatch worn by Suzuki.) If it does, it contains parts made of plastics produced by us. Most of such plastic parts are made of Noryl. We sell Noryl to be used for such small parts by the gram. Most gears and other parts for the calendar mechanism for wristwatches are made of Noryl. We are therefore accustomed to handling such tiny parts. The plastics we sell for such tiny parts amount to a little over 100 kg a month. Among the parts made of plastic are those even smaller than parts for wristwatches. For example, connectors which are almost invisible to the naked eye are also made of plastics.

Suzuki: When I visit plastic product exhibitions, I notice tiny parts which cannot be examined without a magnifier are on display.

Sato: There are various connector makers. Most of the parts for which they use Noryl are such tiny ones.

Candid Advice to the Japanese Engineering Plastics Industry

Suzuki: Are there any comments you can make to commend or encourage the Japanese engineering plastics industry, any advice to be given to it, or any requests to be made of it from an objective standpoint, not as a member of GE?

Sato: Let me see. Well, I'd like to point out a difference between the United States and Japan. It is not limited to a specific industry such as the plastics industry or molding industry. In Japan, when something marketed by a maker proves highly successful in the market, many other makers rush in to the same market. It is a phenomenon which is not normally observed in other countries. Take polycarbonate, for example. There used to be only two makers in the large U.S. market. Only recently, a third maker, Dow Chemical, joined the market for polycarbonate. The third maker came into the market 20 years behind the earlier-starter.

In the Japanese market which is smaller than the U.S. market, there are more polycarbonate makers such as Mitsubishi Gas Chemical, Co., Mitsubishi Chemical Industries, our EPL, and also Idemitsu. As for PBT, there are eight makers, aren't there? Noryl is a plastic which we managed to nurture into a major product, but there are now two more makers, Asahi Chemical Industry and Mitsubishi Gas Chemical. Furthermore, two to three other makers are considering entering the market. When a product introduced by a maker sells well, or the market for a certain product starts growing, everybody come into the same market, causing excessive competition to result. It's an interesting phenomenon which is beyond my comprehension.

Suzuki: I wonder if such a phenomenon observed in Japan is attributable to the intrinsic nature of the Japanese. (Laughter broke out.)

Sato: I don't know about that. It is understandable to some extent that, when a product proves successful, other people enter the market to eventually cause market expansion.

Suzuki: The output of engineering plastics including the five major engineering plastics totaled about 300,000 tons in Japan last year, whereas it was over 400,000 tons in the United States. Right?

Sato: Right. In Japan, there is a total of 28 engineering plastics makers. That's a large number. I have a favor to ask of you. When you interview different people for the following parts of this "High-level Interview" series, will you please ask them how they view the phenomenon we were speaking of?

Suzuki: Thank you for giving me an assignment. (Laughter broke out.)

Sato: That funny phenomenon observed in the Japanese market is what I noticed as a difference between Japan and the United States, or Europe.

Suzuki: That's what happened when I was working for a petrochemical maker. Everybody was rushing into the petrochemical market.

Sato: I know what the rush was like.

Suzuki: After all, Japan is a country of single-rooted, agricultural people. (Laughter broke out.) They do not feel secure unless they are growing the same rice plant as other people, whether it is the "koshihikari" or "sasanishiki" rice plant. These people are afraid of losing money by doing different things. This psychology may have some connection with the market phenomenon at issue. In my opinion, it appears to be a long-fostered characteristics of the Japanese to tend to compete with others, mutually producing similar products which have slightly different features. I admit, I myself cannot talk as if I am an exception.

Sato: I have noticed another difference between Japan and the United States. Putting aside the question of whether it is good or bad, in Japan, the price structure is determined, in a sense, with understanding among the customers, makers, and dealers. In the United States, though it may be partly attributable to the existence of the powerful Fair Trade Commission and the like, prices are in many cases determined unilaterally by makers. In Japan, it would be out of the question for makers to implement price hikes just by sending out notification to their customers. I am not discussing the propriety of pricing systems.

Suzuki: I feel the Japanese way of pricing as described by you has some relevance to the state of over-competition in Japan.

Sato: What is strange in the United States is that, if a maker raises the prices of its products, other makers in the same line also carry out price hikes in rapid succession, no matter how fiercely they are competing with each other in the market.

Suzuki: Does it mean that each industry has a price leader?

Sato: Maybe so. When a maker discloses price hikes, its competitors delightfully follow suit. In Japan, it can happen that, when a maker announces price increases, a competitor considers price reductions for the purpose of increasing its market share. American enterprises do not use such tactics, and I wonder why. Our head office in the United States often gets angry saying: "What on earth are you doing there? Don't sell our products at a bargain. Why don't you raise prices?" I then have to explain, as if making an excuse, saying: "Don't be absurd. We cannot raise our prices as easily here, due to the local custom of trade." In the state, all they have to do to raise the prices of their products is to inform their customers of the new prices and the date when they become effective, in writing. You cannot do that in Japan. This difference between the two countries really causes our head office to get angry at me. As far as I am concerned, that's the biggest difference between the trade practices of the two countries.

Suzuki: Thank you very much for this interview.

20109/6662

CSO: 4306/3570

HANDWRITTEN CHINESE CHARACTER RECOGNITION, CATEGORIZATION STUDIED

Tokyo KEISOKU TO SEIGYO in Japanese Nov 85 pp 19-24

[Article by Kunio Sakai and Haruo Asada, Information System Research Laboratory, Toshiba Research Laboratory, Inc.: "Handwritten Chinese Character Recognition and Categorization Studied--Techniques and Systems for Handwritten Chinese Character Recognition"]

[Text] 1. Preface

This article describes techniques and systems for Chinese characters as viewed from the standpoint of "categorization of multiple patterns." In the case of multiple occurrences, it is the routine means to try to increase efficiency of retrieval and processing by categorization. A familiar, conventional example is categorization of several thousand Chinese characters by left-hand radical, right-hand radical, crown [top] radical, bottom radical, and by the number of strokes (arranged in the Chinese-Japanese dictionary).

Categorization is necessary also when Chinese characters are read by a pattern recognition technique. If not categorized, reading speed drops due to the great number of characters or the scale of the device would become great. Since the initial purpose of categorization for Chinese character recognition is to raise processing efficiency, a machine-oriented, simple categorization method is necessary. However, arranging characters in a dictionary described above is easy for a human to do, but is difficult by machine (for example, reproducing the writing order and stroke numbers of a written character or determining the shape of a corner area where the border is vague). So far, therefore, many methods have been devised as machine-oriented Chinese character pattern categorization methods.

(Footnote 1) (Kawahara, "Handwritten Chinese Character Recognition Research for Which General Categorization Stages Have Almost Been Completed," NIKKEI ELECTRONICS, No 7, December 1981, pp 148-165.) These methods are generally based on extraction of geometric characteristics, pattern matching, and structure analysis.

The second purpose of categorization in Chinese character recognition is categorizing the load to be applied to the recognition system. There are difficulties involved in the Chinese characters besides 1) the enormous number of types, 2) the complex structure of character lines, and 3) the

many similar character pairs involved. On the other hand, the majority of Chinese characters have some characteristics which make it easy to distinguish characters from one another. In addition, these characteristics are really diversified when viewed from various viewpoints. From this fact, the idea of "narrowing down candidate characters for correct solution in stages" has made its appearance. (Footnote 2) (Sakai, et al., "Present State of Printed Chinese Character Recognition," INFORMATION PROCESSING, Vol 22 No 4, 1981, pp 274-279.) The characteristic of this method is that the product of the quantitative spread and qualitative depth of processing to be distributed to each stage is nearly constant and a highly efficient system which is balanced as a whole can be set up.

This article introduces the current state of categorization techniques and the handwritten/printed Chinese character OCR (Footnote 3) (Asada, et al., "Development of Handwritten/Printed Chinese Character OCR," Collection of papers of fiscal 1983 General Meeting of the Institute of Electronics and Communication Engineers of Japan, S10-14, 1983, pp 5-425-5-426.) (optical character reader) based on the above-mentioned multistage processing approach.

2. Categorization of Chinese Character Patterns

The categorization of Chinese character pattern recognition is closely related to identification. Categorization is necessary for the preliminary stage in identification, and that repetition of categorization leading to identification is generally the scheme (Figure 1). What is obtained as a result of categorization and identification is the candidate character set that contains the correct solution category of input pattern. The component elements of this set are affected by the noise that acts on the input pattern and changes each time. That is, a "kind" (set of similar characters) is determined depending on an input pattern and does not exist in advance in a definitely separated form.

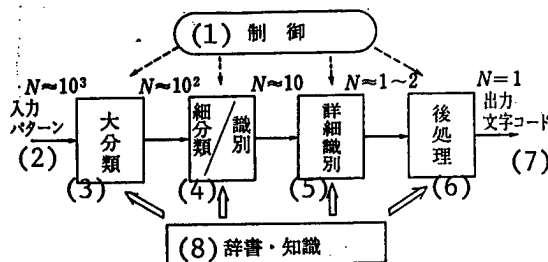

Figure 1. Procedure for Chinese Character Recognition (N: order of number in candidate characters)

Key:

- | | |
|-------------------------------|----------------------------|
| 1. Control | 5. Detailed identification |
| 2. Input pattern | 6. Postprocessing |
| 3. General categorization | 7. Output character code |
| 4. Subdivision/identification | 8. Dictionary knowledge |

In order to categorize and identify, it is necessary to determine how the characteristic quantity is characterized against the target pattern and in what types of scale to use for measuring similarity of input pattern and standard pattern. Also, the following could be considered as an evaluation standard for categorization and identification.

- 1) Efficiency--The average number and quantity of dispersions of candidate characters
- 2) Precision--Probability of correctness within the candidate character set or the reverse (erroneous categorization rate)
- 3) Reliability--Degrees in efficiency decreasing and precision of low-quality patterns
- 4) Simplicity--Ease of realization method, processing speed.

Table 1 is the method for categorization made public thus far and shows the general tendencies with reference to the above standards. There are no schemes showing superior characteristics at all points, but it can be said that those which are simple and capable of high-speed processing are suitable for general categorization and those that take time but are highly distinguishable are suitable for detailed categorization.

3. Categorization Based on Geometric Characteristics

In character recognition, extracting characteristics of character patterns are divided into those taken from character lines, backgrounds or contours of borders of both above items. From another viewpoint, characteristics of character patterns can be classified into characteristics of one whole character, those which are abstracted with attention to parts of a character and those which are highly characterized by local accumulating relationships among characteristics of parts. Some characteristics are represented by simple scalars while others are represented by multidimensional vectors depending on to what degree of detail these characteristics are described respectively.

Since unlike alphanumeric characters, Chinese characters are complex and numerous in number, depending on categorization characteristics a powerful type is necessary. It is important to diversely investigate the target Chinese character patterns and clarify their nature in order to find effective categorization characteristics.

In the past, much research was done from such a standpoint and the following are the findings of such results (see Footnote 2).

- (1) There are complex Chinese characters and others are simple. If a quantification scale of complexity can be found, it will be useful for categorization and identification.

Table 1. Methods of Categorization and Identification of Chinese Character Patterns

Type	Method	Characteristic
Based on extracting geometric characteristics	Density of character lines	Characteristics to correspond with complexity of character. Easy to extract and having highest categorization power independently.
	Background pattern of peripheral parts	Characteristics to correspond with intuitive representation of character line layout
Based on pattern-matching	Complexed similarity degree	Characteristics of shaded distribution. High capability obtained in a simple operation uniformly.
	Directivity matching	Characteristics of line-element directional distribution. Much operational quantity great but high identifying capability of similar characters.
Those based on structural analysis	Relaxation method	Effective even for unbalanced deformed characters. Numerous computational quantity for matching.
	Proportionate pattern matching	Effective for distinguishing against similar character. No established method is available yet.

(2) On the other hand, the circumference of Chinese character pattern (contour part) also contains much identifying information. Effective characteristics can also be extracted from this.

(3) Since the Chinese character pattern is diversified, a uniform categorization would be easier by not only using one method, but also using multiple methods together.

Table 2 graphically shows representative categorizing procedures from the viewpoint of characteristics extraction. What sort of characteristics were extracted from each character pattern is outlined below.

Complexity index and average number of lines include densities of character lines measured in longitudinal, traversal (oblique) directions and intuitively correspond to the number of strokes. Stroke density distribution, directional contributory density, etc., are characteristics detailing these types.

Table 2. Distribution of Numbers of Loops in Chinese Character " 田 " [TA]

Number of loops	0	1	2	3	4	Total
Data base						
ETL9 number	40	41	58	37	24	200
(percent)	(20.0)	(20.5)	(29.0)	(18.5)	(12.0)	(100)
ETL8 number	34	34	31	34	27	160
(percent)	(21.3)	(21.3)	(19.4)	(21.3)	(16.9)	(100)

Area between lines, background area and peripheral pattern are characteristics noting the blank area of a character--that is, its background. The area between the lines of the blank area of adjacent lines. The shape and background area is the the length from top, bottom, left, and right character frame sides to the outermost contour character lines (state of indentation), and the peripheral pattern is the characteristics dividing this characteristic into small areas for vectorization.

Contour line length is the characteristic related to general shape and length of contour line (complexity of character periphery) positioned at the outermost contour as viewed from top, bottom, left, and right character frame sides.

Peripheral distribution is the characteristic obtained by addition of numbers of character lines, and the length of blank, and the dark areas from one character frame side to the opposite character frame side.

Characteristic locus is the characteristic of extended feelers from top, bottom, left, and right and the line segments which intersect until the character frame side is reached. The structure-integrated characteristic is obtained by enhancing this characteristic for the purpose of reflecting character lines inclined toward blank areas.

As mentioned above, there are numerous characteristics in the classification of Chinese character patterns. However, when multiple kinds of characteristics are combined as one categorizing technique, it is also important that the characteristics are of different nature. That is, the point is to investigate how individual characteristic values change the input patterns by the added noise and selecting those which behave complementarily.

Since the categorizing technique based on extraction of geometric characteristics is often used for general categorization, methods of computing characteristic values are generally simple. For example, the characteristics shown in Figure 2 are all extracted by scanning the input pattern in longitudinal, traversal, and oblique directions.

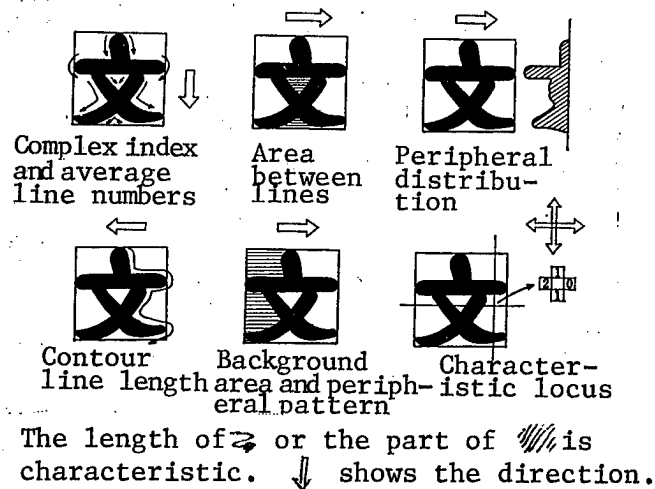

Figure 2. Various Methods of Extracting Geometrical Characteristics

The barter curve shown in Figure 3 is conveniently used to visually grasp categorization characteristics. To obtain these curves, it suffices to enter many patterns into a categorizing system and to obtain the number of average candidate characters N and erroneous categorization rate E , with the discrimination threshold value as the parameter. Naturally enough, the efficiency (small N) and the precision (small E) are factors which contradict each other. That a technique which does not come off the allowable area on the N - E plane even if character quality deteriorates--that is, which is highly reliable--is known to be satisfactory.

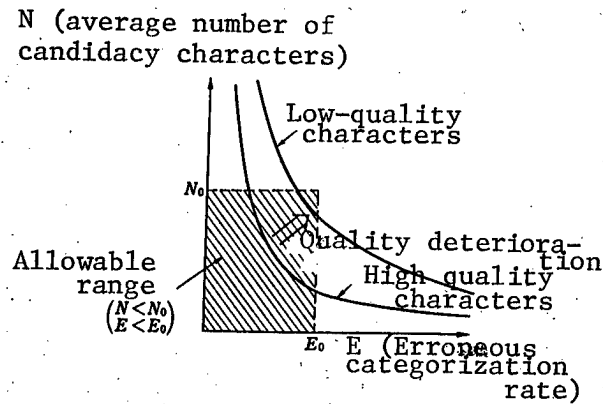

Figure 3. Relationship Between Categorization Effectiveness and Categorization Precision

4. Categorization Based on Pattern Matching

After various kinds of Chinese characters have been generally categorized, processing enters the stage of categorizing obtained candidate characters in more details. Think about a case where a person reads Chinese characters.

If an adult, he would read Chinese character patterns of complex shapes without difficulty at an amazing speed, an unbelievable speed so it is questionable whether a detailed analysis of geometric shapes of Chinese character patterns was made. Rather, it is believed that through quickly grasping overall characteristics of Chinese character patterns, a comparison is made with standards acquired by lengthy education and learning. Such a method is also being widely used in the case where a machine is made to read Chinese characters. That is, the method is in seeking characteristic patterns that represent Chinese character patterns as a whole, to superimposing the pattern on standardized characteristic patterns calculated beforehand for individual types of characters, and identification made based on the degree of matching these patterns. Of the Chinese-character-recognizing algorithms that have been publicized up to now most of those which are near to being placed into practical use adopt such an approach. This is called the pattern-matching method.

The greatest advantage of such a method is that if Chinese character patterns are represented as characteristic vectors, the scale of similarity can be obtained simply with inner operations, etc., for uniform processing. Also, since a standard pattern can be automatically generated, it is considered to be most suitable for categorization of the several thousand kinds of Chinese characters. However, with regard to the types of characteristics, there is a limitation in image processing capability of a machine which is far inferior to that of a human comparatively as to precision and speed. At present it is not in the stages which allow high-speed extraction of characteristics as efficiently as when extracted by a human. The current status is that candidacies, which have been narrowed down to about 100 in general categorization, have now been improved to several types of candidacies.

A concrete description of the method follows. Pattern-matching techniques are classified into the following three kinds depending on which characteristic is selected.

(1) Geometric Characteristic

This is the technique which divides a Chinese character pattern into partial areas of about 4×4 or 8×4 , average sectional geometric characteristics measured for individual pixels, and represents a Chinese character as a characteristic vector of 16 to 256 dimensions. As to the kinds of characteristics, the characteristics described in the previous chapter are detailed further and used. As a scale of similarity, a simple city block distance is mainly used, and in addition, the Euclid distance and the Maharanobis' general distance are used. Furthermore, the modified Maharanobis' general distance that ignores covariance is sometimes used. Since when only one kind of characteristic is used, only capability comparable with that of general categorization is obtained, multiple characteristics are combined to enhance capability.

(2) Line Element Direction

A Chinese character pattern is composed of various strokes, the majority of them linear. The part and direction of the respective stroke of a Chinese character pattern becomes an effective characteristic for identification of the character. Unlike the structure analysis method described in the following chapter, which does not handle strokes as graphics, this technique considers the direction of a line element as the component element of the stroke, and makes the two-dimensional pattern obtained by taking out only the line elements in the same direction of a characteristic. To be more concrete, this technique makes a differential pattern obtained by operating first order differential operators in several directions on a Chinese character pattern as the characteristic vector. Usually, four to eight directions are used. There is a report (Footnote 4) (Yasuda, et al., "Improvement of Correlation Method for Character Recognition," Communication Related Papers (D), J-68D-3, 1985, pp 353-360.) about vagueness being added to the differential pattern using position-corrected simple similarity as the scale of similarity. Moreover, the technique which uses complex similarity as the similarity scale is called a complex structure similarity method (Footnote 5) (Maeda, et al., "Introducing Local Structure Pattern Matching Method," Communication Related Papers, J68-D-3, 1985, pp 345-352.) and is reported to be effective for identification of similar character structures such as "職," "織," and "織."

(3) Shade

A light and shaded image obtained from observation of a pattern can also be made a characteristic. Since various characteristics as graphics described so far can all be computed based on this, the information necessary for identification of Chinese characters can be said to be included in all this. However, since the information is simple as a characteristic and has not been condensed, a satisfactory capability cannot be obtained when a simple similarity scale is used. The best correct reading rate based on simple similarity degree was 74.8 percent for the handwritten Chinese character data base gathered by the Electron Technical Laboratory (ETL8: 956 kinds of characters 160 persons). (See Footnote 4) The simple similarity degree is the correlation coefficient between an unknown input pattern and the standard pattern, and if a Chinese character pattern is considered to be a vector in a characteristic space, the simple similarity degree can be said to have the angle between itself and the standard pattern vector its scale. Therefore, if a learning pattern set correctly reflects deformation of actual patterns, diversified deformation of handwritten characters can also be absorbed.

5. Categorization Based on Structure Analysis

A child who has started studying Chinese characters, in learning new Chinese characters, analyzes one point and one stroke carving their positional relationships into his brain. A child who has learned Chinese characters to some degree begins to remember new Chinese characters by combining somewhat larger unit such as the left-hand radical, right-hand radical, or the already-known Chinese characters used as partial patterns (for example,

"心" [heart] in "愛" [love], etc. And, when such a Chinese character is encountered, the child recognizes it based on theoretical inference by disassembling it into partial patterns. In this way, the structure of Chinese character pattern is in level layers, and the method first thought up to have a machine read Chinese characters was in making use of this hierarchy. Input Chinese character patterns are represented separately by parts and are recognized by matching these representations with each individual structure of Chinese characters written beforehand. Since simple description suffices for the standard type of each Chinese character, it is easy to teach a machine new Chinese characters in the same way as when a child is taught Chinese characters. However, this approach has not been successful so far. This is because there are unexpected cutting and contacting between strokes in handwritten Chinese characters, and no suitable graphic processing algorithm is available for the correct separation and integration. According to a report (Footnote 6) (Saito, et al., "JIS Level 1 Handwritten Chinese Character Data Base ETL 9 and Its Analysis," Communication-Related Papers (D), J68-D-4, 1985, pp 757-764.) on analysis of data bases, ETL's 8 and 9, even the nature of basic linkage and the number of holes have not been retained (Table 2). Furthermore, partial disassembly is deeply related to the long-sustained research called form recognition of graphics and can be said to be a very difficult issue.

At present, the following two approaches are said to be representative as realistic and are taken as a structure analysis method:

(1) Symbolic Description of Graphics Matching

This method approximates character contours with straight lines, etc., representing a series of Chinese character patterns that recognizes the character based on symbolic matching. The difference of the symbolic matching from the matching described in the previous chapter is that for the latter, the characteristic is a two- or one-dimensional array of scalar quantities, but for the former, the characteristic is an attributed symbol series. The unit of description is a smaller segment which configures a stroke. The characteristic of this method is integration of these segments to directly identify a character without interpreting. Thus, this method avoids the difficulty of graphic recognition mentioned earlier. The method using relaxation (the relaxation method) is typical as a successful example of the method. (Footnote 7) (Yamamoto, "Handwritten Education Chinese Character Recognition Based on Relaxation Matching Method," Communication-Related Papers (D), J65-D09, 1982, pp 1167-1174.) This method first approximates character contours with a polygon and makes the side (segment) of the polygon the descriptive unit. Descriptive items are coordinates of the starting and ending points, the direction and the length. Then, all the input segments are made to correspond with the dictionary segments and the corresponding degree is obtained as an adaptation coefficient. Relaxation is then applied with the connection and position relationships of segments as restrictive conditions, and the character which indicates consistent correspondency as the character as a whole is the result of recognition. The time required for recognition is longer than that of the pattern-matching method (a few seconds for one character) but practicalization is possible through hardware enhancement.

(2) Sectional Matching

In order to select one character among the few candidate characters selected by the pattern-matching method, this approach is attentive to partial patterns of a Chinese character. As many Chinese characters have the same left radical but a different right radical or only partially differing from one another like "微" and "徽," they cannot be identified with high precision by the pattern-matching method. Therefore, it takes notice of different parts to find a key to identification.

This method is further subdivided into two categories: a) one generating mask of partial patterns for pattern matching and b) another separating partial patterns as graphics. Recognition is made through using either of the methods. Both are used in the detailed identification after pattern matching. Since in this case, the radical type and the kind and approximate position of the partial pattern to be noted are known in advance, top-down processing becomes possible and partial division becomes comparatively easy. In this approach, processing distribution described in Chapter 1 is being effectively conducted to make the cost-effectiveness ratio optimum. However, when deformation of many handwritten characters are taken into consideration, the techniques for partial pattern extraction and identification of the position are still unrefined and functional improvement to be attained by this method is not expected at present to be so great. Research in the pattern-matching method has come to a halt, and research in this field will probably become active in the future.

6. Handwritten/Printed Chinese Character OCR (Optical Character Reader)

It is comparatively long ago, going back about 15 years, that research in Chinese character recognition started in Japan. During this time, research has evolved from recognition of printed Chinese characters (see Footnote 2) to that of handwritten (see Footnote 1) characters and research has recently progressed to product development stages. The purposes and effects of categorization techniques are to be shown more concretely here with a system (see Footnote 3) capable of reading handwritten and printed Chinese characters as examples.

The first level layer of this system is the general categorization based on extraction of geometric characteristics and enhances the categorization effect by combining complementary characteristics such as "average number of lines," "background area," "contour length," etc., from among the characteristics shown in Figure 2. The secondary level is the identification based on degree of complex similarity, which is one of the pattern-matching methods, and provides stable recognition capability for the deteriorated print quality and deformed handwritten character. The third level is the detailed identification which performs contour analysis with circular arc approximation and is used for similar character discrimination based on top-down driving. The postprocessing in the fourth level differs in that it processes a symbol called a character line as a result of recognition rather than processing at the level mentioned so far as the pattern level. That is, this method reduces the vagueness of pattern recognition and using knowledge

Table 3. Standard Specifications for Written Character Recognition (OCR-V/595)

Read character and the like	2,200 types of printed written characters
Character recognition speed	50 characters per second
Modification format	Candidate selection and Kana-Kanji conversion
Knowledge base	Address, name, other (such as company or commodity name)

Although the number of Chinese characters are numerous and complex, they are easy to understand. This is what is experienced daily. Probably, the Chinese character pattern effectively laying out diversified graphic elements on a two-dimensional plane conforms well to the characteristics of human vision and memory. Also, it is pointed out that anyone who had studied Chinese characteristics of human vision and memory. Also, it is pointed out that anyone had studied Chinese characters well passes the stages of overall recognition, partial recognition, and finally, recollection of the meaning and reading in this order when recognizing a Chinese character. (Footnote 8) (Watanabe, "Chinese Characters and Graphics," NHK BOOKS 264, Nippon Hoso Kyokai, 1976.) The Chinese character OCR described in the previous chapter is very interesting in that coincidentally it takes a similar pattern to that as described above.

Reading Chinese characters by machine is important not only from the standpoint of pattern recognition, but also from the aspect of social needs that involve enhancement and spread of Japanese information processing. For example, in order to build data bases for patents, literature, real estate, commercial registration, newspapers, enterprise management information, etc., and conduct retrieval services, it goes without saying that input automation is a prerequisite. In this sense, high-speed inputting of massive data by using a Chinese character OCR is realistic and effective and has already been put into practical use. On the other hand, demands for direct inputting of handwritten characters and printed matter have increased in offices and homes. To respond to these needs, processing of documents with pictures where characters, illustrations, and photographs are mixed, high-level language knowledge processing which automatically performs checking of erroneous reading and keyword extraction, etc., will become important in the future. Further developments in character and graphic pattern recognizing technologies are expected.

20111/9365
 CSO: 4306/1531

COMPUTERS

RECENT PROGRESS OF SIGMA SYSTEM REPORTED

Tokyo JECC NEWS in Japanese 1 Feb 86 pp 4,5

[Article: "Development of Sigma System Aimed at Preventing 'Software Crisis' and at Promoting High Information Society"]

[Text] The Sigma System is a 5-year development project (1985-1989) called "Software Production Industrialization System." The Information Processing Association (IPA) (director: Jiro Adachi) has invested ¥25 billion in the project. The objectives of the system are to prevent a "software crisis" in the near future and to efficiently systematize software production in Japan. To attain these objectives, the system aims: 1) to improve quality and productivity; 2) to prevent duplicated development of software; 3) to improve the equipment to develop software and to accumulate expertise; and 4) to educate engineers efficiently.

The Sigma System Development Team (chief: Ken Tsujioka) is in charge of the development of the Sigma System. It is staffed with about 50 members, including those dispatched from enterprises. In order to start fullfledged operation in 1990, the team aims: 1) to establish a standard developmental environment which allows the user to develop software independently from the hardware which actually executes the program; and 2) to establish a network system for the retrieval and transmission of programs and technical data.

This year marks the second year of the 5-year development plan and is an important year in establishing the foundation for trial service to begin in 1987.

Software Crisis

There are three reasons for the observation that a software crisis will certainly come in the near future.

1. Increasing gap between software supply and demand

In accordance with the rapid progress of the information society, the demand for software has been growing drastically at an annual pace of about 26 percent. On the other hand, technology to develop software has not yet progressed sufficiently, and software productivity shows almost no improvement.

The development of software still depends upon manual labor, while the number of software engineers grows by only 13 percent annually. Because of these factors, it is forecast that there will be a shortage of about 600,000 software engineers in 1990.

2. Increasing software cost against cost of the entire computer system

The cost of hardware has been declining due to the progress of electronic technology, while software has become larger and more complicated due to the more advanced hardware. The technology to develop software efficiently, however, has not yet developed sufficiently. On the otherhand, more and more accumulating software has been increasing maintenance costs. In this situation, it could be that software will cost 5 or 10 times more than hardware. The percentage of software cost in information processing costs has been steadily increasing.

3. Need for high quality software

Since computer systems are being used more and more in the important fields of society, there have been increasing needs for more secure and reliable systems. There is also another increasing need for software among nonprofessional users in the booming field of personal computers. In either case, users are now looking for higher quality software. This tendency is likely to be promoted further in the future.

Structure of the Sigma System

As indicated in Figure 1, the Sigma System consists of three major sections.

1. The Sigma Center

The Sigma Center controls and coordinates the entire Sigma System. It plays the role of data base for the program products such as tools and modules, as well as for technical data. It also offers a network service such as electronic mail and file transmission. The Sigma Center consists of five subsystems which are described in Figure 2. These five subsystems have the following responsibilities:

a. Network service subsystem: This subsystem controls and coordinates the entire network of the Sigma Center. It plays the role of FEP (front end processor) for the other four subsystems.

b. Data base service subsystem: This subsystem controls and coordinates a data base and files accumulated in the Sigma Center. It provides users with information, tools, and packages.

c. Developmental environment subsystem: This subsystem provides the staff members of the Sigma Development Team with the environment to develop the Sigma System. It supports the team to develop and test tools. It also helps them promote computerization in their office. With the introduction of two UNIX computers in fiscal 1985 (VAS 785 was installed last November), the subsystem will be operable in fiscal 1986.

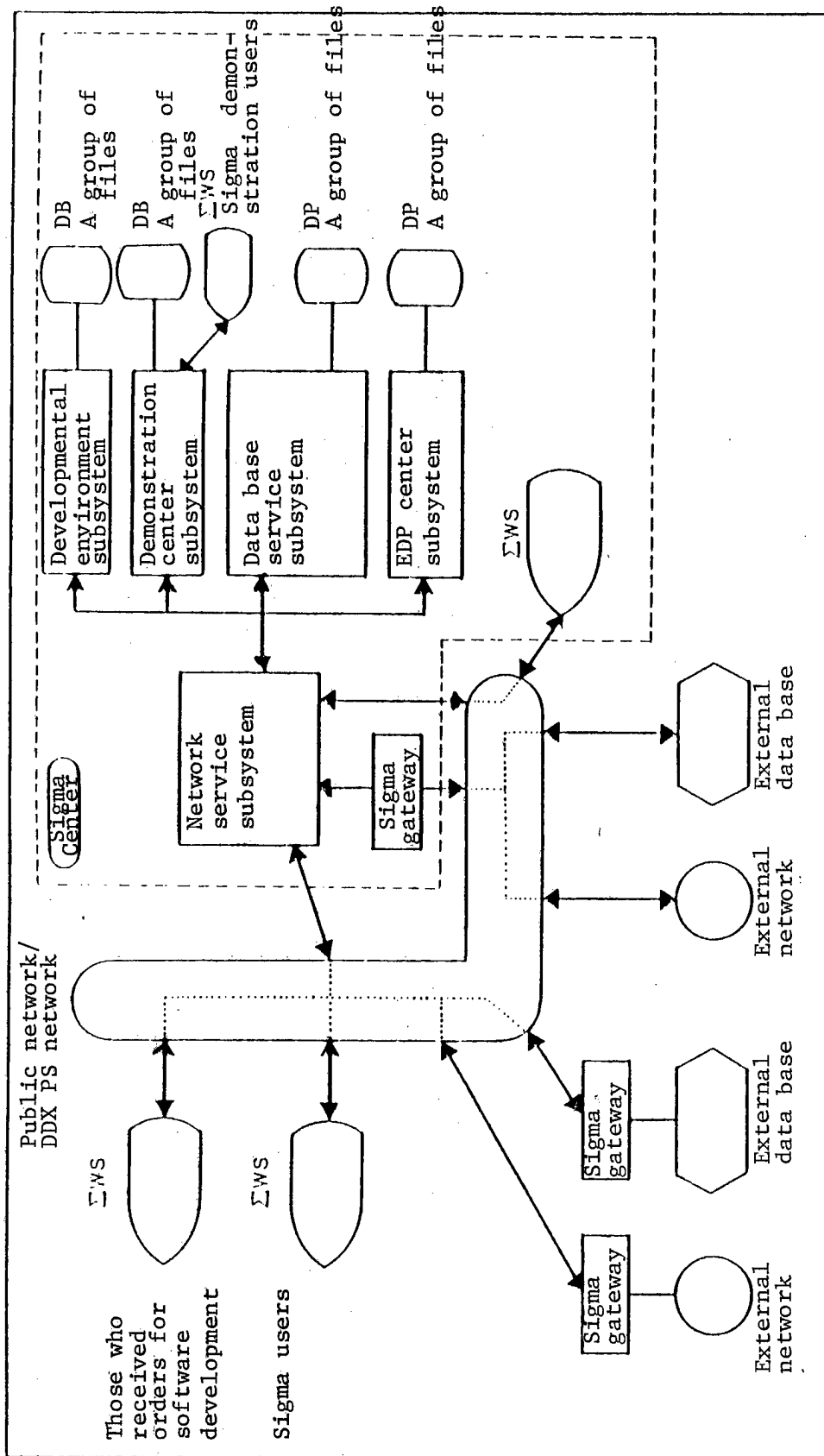

Figure 2. Structure of Subsystems

d. Demonstration center subsystem: This subsystem provides a demonstration environment for the Sigma System, and executes demonstration on request.

e. EPD center subsystems: This subsystem processes daily business chores to be generated when the Sigma System starts its business operation.

2. Sigma Network

This is a logic network linking the Sigma Center and users through which programs and data will be transmitted. This network will use DDX packet network service for its communications circuit with transmission speed, reliability and economy being considered. For telephone network users, it will use a network linkage service which allows users to use a DDX packet network through a telephone network. The question will be discussed in the future as to how to link the Sigma Center with external networks, external data bases and external target machines for test runs (the computer which executes the program developed is the Sigma WS).

IPM will decide the protocol, in addition to the protocol which is currently supporting the UNIX communications function, considering the future trend of UNIX and ISO's attempt to develop standard open system interaction (OSI).

3. User site

This section features workstations and multiple-use computers to be linked with the Sigma network through Sigma OS and the data base and general computers for test runs communicated through the Sigma gateway. These facilities are installed by users.

The Sigma workstation (Sigma WS) is the software developmental facility (software and hardware) installed by users. Its cost performance allows one software engineer to use one computer. A prototype Sigma WS will be constructed with the hardware supply described in Table 1 and with Sigma OS-VI as the operating system. It will be used when the Sigma System begins trial operation in 1987.

Sigma OS is an operating system for software development to be applied to the user site. It has two functions: the AT&T edition UNIX and the Berkley edition UNIX. Software developmental tools of either edition can be operated through the Sigma OS. Also, Sigma OS will have other functions such as Japanese processing, graphics, multiwindows, data base, and powerful communications. Sigma OS-VI is the first edition of Sigma OS defined by IPA.

Available Service From the Sigma System

The Sigma System aims to dramatically improve the productivity and reliability of all software production in Japan. This will be assisted by the standard operating system for software development installed at user workstations, and by various functions of the Sigma Center. The Sigma Center provides users with the following service:

Table 1. Prototype Sigma WS Hardware Supply (Plan)

	Requirements	Note	
Basic components	Price	¥3 million	
	CPU	32 bits	
	Performance	1 MIPS or more	
	Floating point processor	Standard supply	To be built in CPU board
	Main memory capacity	4 MB or more	
	Magnetic disk	80 MB or more	5 inches
	Streamer MT	40 MB or more	
	Floppy disk	5 inches 1.6 MB	Format to be decided later
	Serial I/F	RS-232C, four or more	
	Parallel I/F	One centronics or more	
	Display device	Bit map (1,000 x 1,000 dots or more) Four windows or more *Colors optional	Size: 14"-20" Display speed: 1 sec/1 screen or less (In case of full screen displayed with kanji)
Pointing device	Mouth, two buttons or more		
Keyboard	JIS modified type	Requirements in keyboard such as function keys to be determined later	
Laser printer	Communications interface	LAN IEEE 802.3 inter- face Global network x.25 interface Standard bus GP-1B Serial I/F RS-422	For linkage with IMB-ICE (In-circuit Emulator)
	Additional functions	300 dots/inch or more A4 size: 10 sheets/ minute or more	Thermal, dot impact types can also be used

1) An operating system for the development of standard software applicable to the software developmental business.

2) Data base service such as retrieving information concerning software development supporting tools, multiple-use programs, and software modules, or the programs themselves and related information, including data on systematized technologies to develop software and reference books.

3) Network service which allows users to use data base service at user sites all over the country, and file transmission and electronic mail service so users will be able to transmit documents and exchange information with other users.

4) Education programs to train users on how to use the Sigma System and to provide knowledge on software development technologies.

Advantages of the Sigma System

The most vital advantage of the Sigma System lies in the dramatic improvement of software productivity and reliability. It is also expected to help greatly improve the software developmental environment, and promote distribution of individual software resources.

1. Improvement of software productivity and reliability

The Sigma OS is perfect for software development. In addition, various tools will be available at the Sigma Center. The general tool market will be expanded since tools will become more compatible. Unified operating procedures will make engineers learn it easily in depth. Various information on software development will be available on a timely basis at a cheaper cost. All these factors will drastically increase software productivity and reliability.

2. Promoting distribution of individual computer resources

By sharing the common developmental environment linked by network, each user will obtain closer access to software resources which each user keeps individually. Distribution of packaged programs will also be further promoted.

3. Improvement of developmental facilities

The Sigma WS is a standard environment for software development independent from hardware. Therefore, users can concentrate on the Sigma System free from the trouble of developmental facilities which occurred when they had to develop software for more than one computer in different models.

4. Improvement of user education

The Sigma System will have HELP and menu functions to help users. The Sigma System will make CAI programs to educate users on how to use tools provided by the Sigma System and how to develop software. Thus, user education will become more efficient.

5. Establishment of standards in developing software and integration of basic data

Through the development and operation of the Sigma System, technology standards to develop software will be established from coded interface to guidelines for project operation. Consequently, software engineers who suffer

Table 2. Data Base Groups

Name of data base	Contents	Name of center in charge
Members data base	Store data concerning Sigma System members	Information network service center
Tool data base	Store various tools and related documents registered in Sigma Center	"
Tool catalog data base	Store data concerning Sigma System members	"
Software fact data base	Store various data concerning software development	Developmental environment center
Registration data base	Store data concerning tool users registered at Sigma Center	Information network service center
Index information data base	Store index of data stored in each data base, educational data and the data of external data bases	"
Maintenance information data base	Store data concerning maintenance of various tools, claims, and requests	"
Product shipment data base	Store data concerning shipping of various products from Sigma Center	EDP center
Levied charges data base	Storing information on levied charges, such as the usage status of the Sigma System by subscribers	Information network service center
Advanced technology information data base	Store information concerning advanced technologies appearing in newspapers, magazines, and books	"
Demonstration program data base	Store demonstration programs registered in Sigma Center	Demonstration center
Accounting data base	Store data concerning accounting of Sigma System	EDP center

from "dialogues" will be able to speak in a "common language." While the Sigma System is being developed, basic data concerning software development will be collected and organized efficiently.

20134/9365
 CSO: 4306/1544

DEFENSE INDUSTRY

POSSIBLE MILITARY APPLICATIONS OF STRATOSPHERIC AIRSHIP DISCUSSED

Tokyo BOEI GIJUTSU in Japanese Nov 85 pp 48-58

[Article by Junichi Kimura, Second Division, Third Laboratory Institute [TRDI], Defense Agency; Ryuichi Takeda, First Division, Third Laboratory, TRDI; Yukichi Fujimatsu, Test Team, Gifu Experimental Station, TRDI; and Toshiyuki Kato, Air Testing Group, Air Self-Defense Force, Defense Agency: "Feasibility Study of Airship for Military Use--Part 3"]

[Excerpt] 3. Conception of Defense Use of Stratospheric Airship

(1) General

This is a study made of the possibilities of a stratospheric airship of the LB (lifting body) type from the aspect of operation. Let us first see the details of aerological conditions that most severely restrict its operation and then consider the scope of its operation for the purpose of defense according to its characteristics.

(2) Restrictive Meteorological Conditions

a. Outline

The atmosphere is normally divided into six parts, the troposphere, stratosphere, chemosphere, ionosphere, mesosphere, and exosphere. In the stratosphere, which is 12-30 km in altitude, the temperature is approximately constant and the air is stable and normally cloudless. Here follows a study made of the conditions of the stratosphere above Japan based on the AEROLOGICAL DATA OF JAPAN published by the Meteorological Agency in March 1983 (to be referred to hereafter as "meteorological data"). These meteorological data are statistical data gained from aerological observation and consolidate monthly means of data acquired at 0900 and 2100 hours every day at 18 Japanese observatories from Wakkanai to Minamitorishima. They comprise geopotential altitudes, air temperatures, humidities, wind directions, and wind speeds at 25 designated barometric levels from 1,000 mb to 5 mb.

In this study, data from 1961 and later were used.

b. Wind Speed

Figure 19 shows the means of lowest and highest wind speeds at the different designated barometric levels at 0900 and 2100 hours from the meteorological data. From these charts, wind speeds at altitudes of 20-25 km are low at both 0900 and 2100 hours and the maximum wind speed is about 25 m/sec, which is lower than the night design wind speed of 28.3 m/sec.

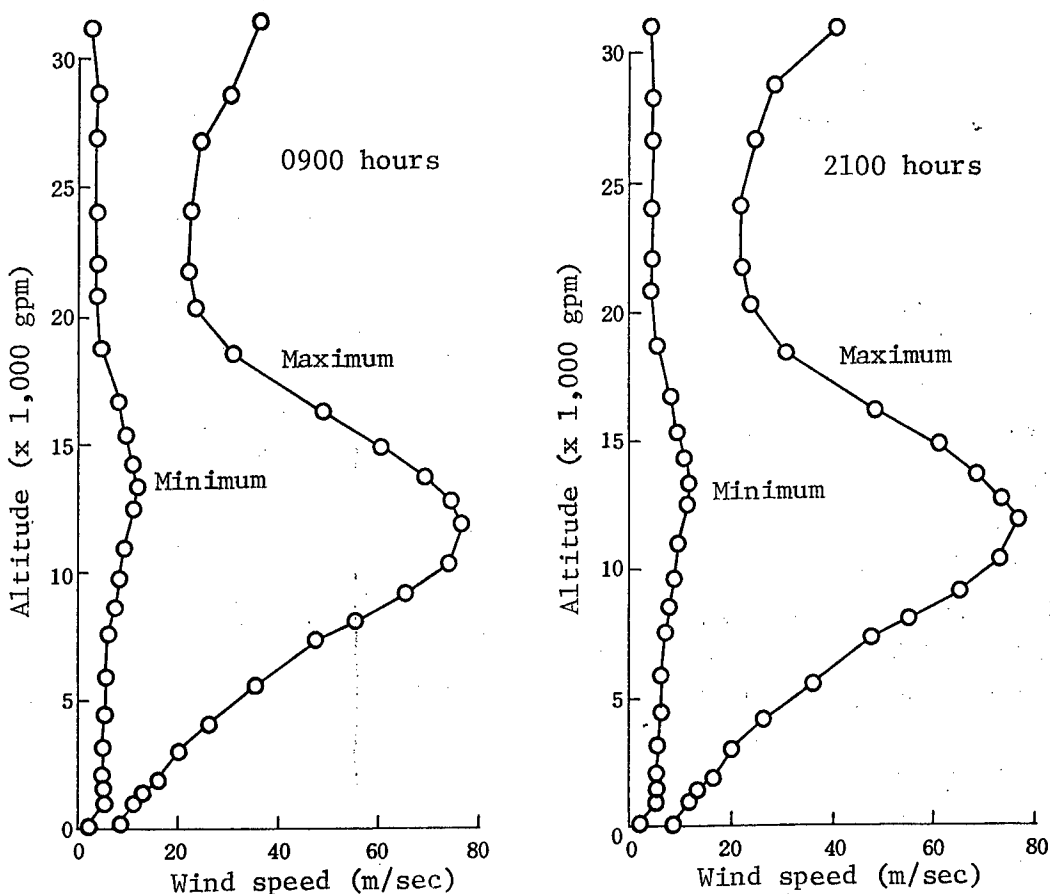

Figure 19. Minimum and Maximum Wind Speeds in Japan

Further details of winds at the altitude of about 20 km are as follows:

Figures 20 and 21 show 2σ and 3σ , monthly means at the altitude of 20 km at 0900 hours at, respectively, Wakkanai and Chichijima. From these charts, the design wind speed is not expected in daytime in any month even above Wakkanai where wind is strongest provided that it is mean + 2σ . So, the airship can stay there with the probability of more than 97.7 percent.

At night, meanwhile, the design wind speed, if it is mean + δ , is exceeded only at Wakkanai in December since there are hardly any wind speed differences by hours.

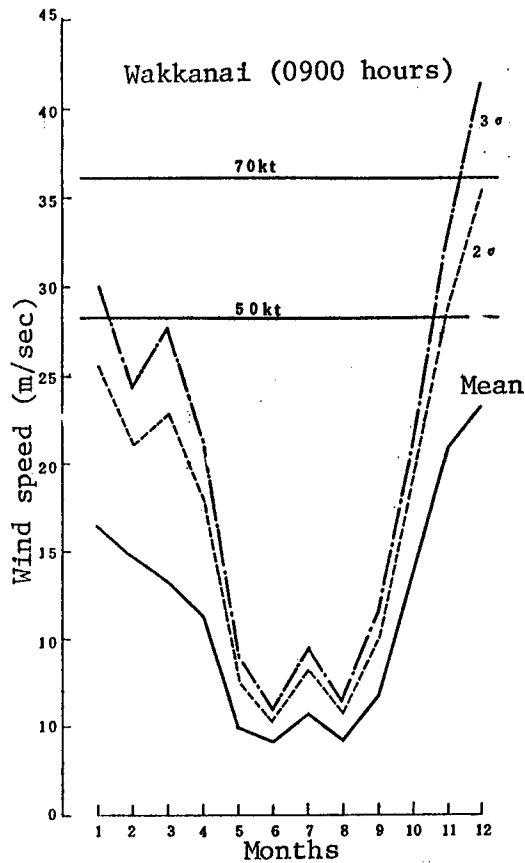

Figure 20. Mean Wind Speeds at Wakkanai by Months and Distribution (0900 hours)

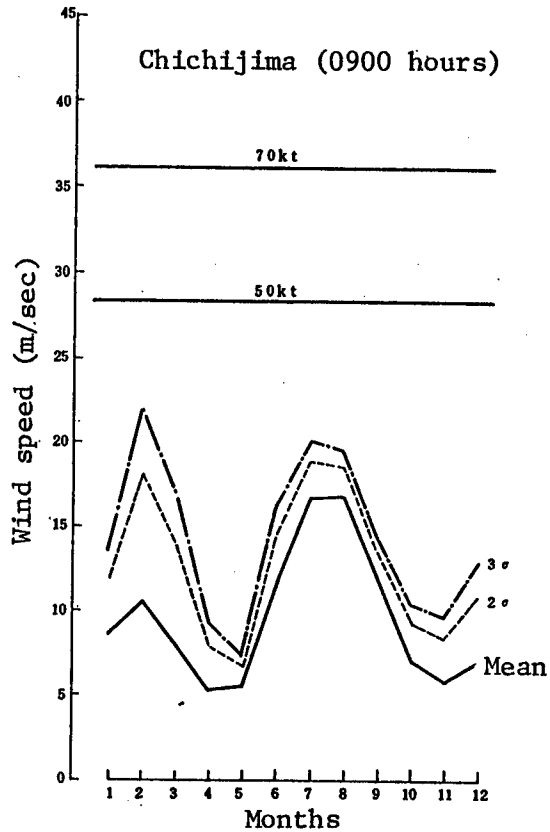

Figure 21. Mean Wind Speeds at Chichijima by Months and Distribution (0900 hours)

c. Wind Direction

From the meteorological data, wind direction 20 km above Japan is westerly in winter and easterly in summer. The period of west wind is long as you go north (9 months at Wakkanai) and the period of east wind is long as you go south (6 months at Chichijima). The time wind direction changes from westerly to easterly is clearly defined in the north but indistinct as you go south and there are periods of north or south wind.

The west wind is about 270° in the southwestern areas and is bent to the north as you go north so that there is a difference of 20° to 30° between Ishigakijima and Wakkanai. The east wind, meanwhile, is steady at about 85°.

Figure 22 shows wind direction and wind speed on the 50 mb barometric level in December as typical of winter while Figure 23 shows wind direction and wind speed on the 50 mb barometric level in July as typical of summer. Data from observation at 0900 hours were used for these charts but there are no known differences by hours of observation except for some hours of change from west wind to east wind.

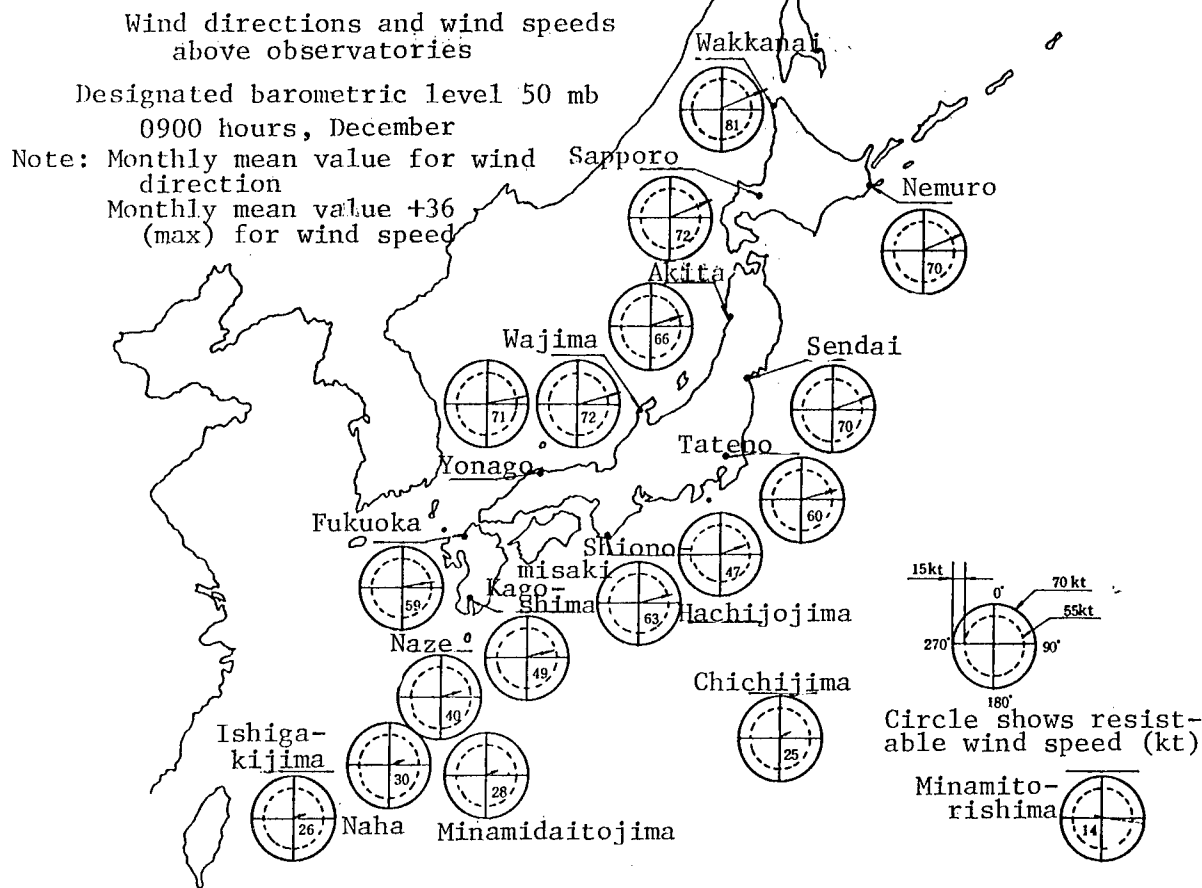

Figure 22. Wind Directions and Wind Speeds Above Observatories (Winter)

The areas where the 3δ value of wind speed exceeds design resistable wind speed abound in the north, mostly in wintertime. Since, however, winter winds in the north blow steadily in a single direction, an airship launched on the Sea of Japan side would drift to the Pacific side if it should ever drift by wind. So, there should not be much of a problem.

d. Temperature

From the meteorological data, air temperature at the altitude of 20 km is considered as follows:

Air temperature is low in summer and high in winter as you go north from the vicinity of latitude 33°N, the boundary. If you go south, instead, it is high in summer and low in winter. Thus, above Japan, the temperature difference is great in winter (about 18°C) and small in summer (about 8°C).

Wind directions and wind speeds above observatories

Designated barometric level 50 mb

0900 hours July

Note: Monthly mean value for wind direction

Monthly mean value +36 (max) for wind speed

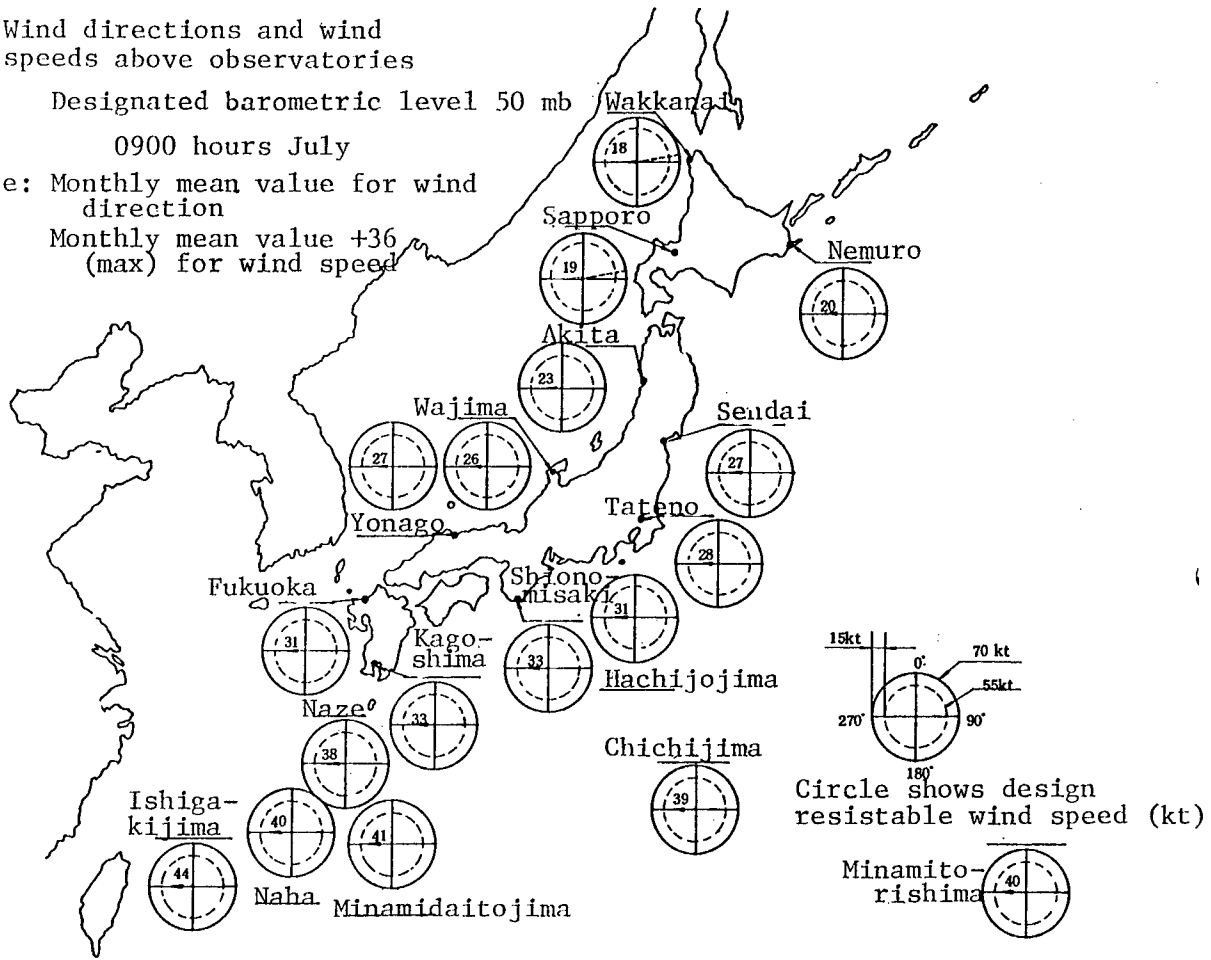

Figure 23. Wind Directions and Wind Speeds Above Observatories (Summer)

Compared by mean values, it is higher in the northern direction and lower in the southern direction--contrary to the tendency near the ground surface. So, the highest temperature of the 18 observatories is -47.1°C at Wakkanai in January and the lowest temperature is -66.9°C at Minamitorishima in December. Standard deviations range from 2.9°C to 0.6°C ; they are large in winter and small in summer.

Figure 24 shows a comparison between Sapporo with highest air temperature and Minamitorishima with lowest air temperature. It indicates that, unlike on the ground surface, there are no great differences by hours of observation.

e. Others

The above are wind speed, wind direction, and air temperature above Japan, particularly at the altitude of 20 km, based on the meteorological data. Meteorological phenomena posing threats to the airship are thunder and typhoons.

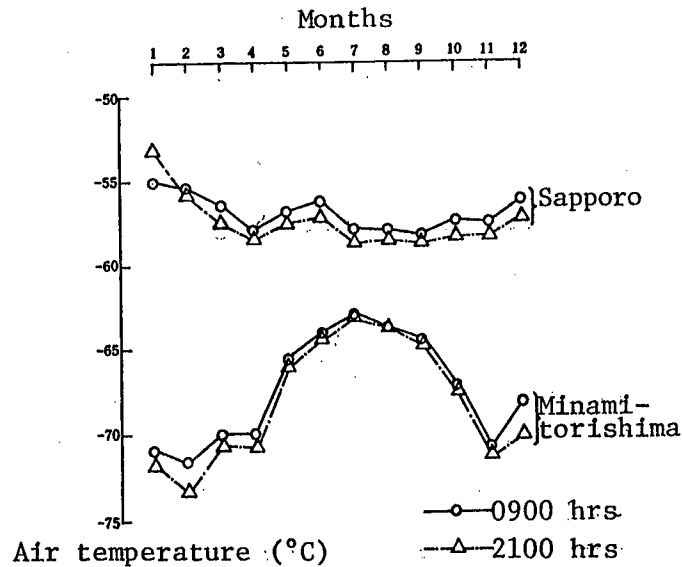

Figure 24. Air Temperature at Altitude of 20 km by Months (Mean value + 3σ)

(a) Thunder

The life of a thundercloud is normally divided into three stages: cumulus stage, mature stage, and decay stage (evanescence stage). In the cumulus stage the entire cloud is composed of ascending heat cells. The heat cells swell as they ascend and the cumulus ceases to develop when temperature at its top becomes equal to the temperature of the free atmosphere.

When the mature stage starts, the speed of the ascending current sometimes exceeds 30 m/sec and the cloud top reaches 8 to 11 km. In the tropics, it sometimes reaches 15 to 18 km. Raindrops or hailstones begin to fall, pulling air around them and turning it into a descending current. At the mature stage, the ascending current and the descending current adjoin each other.

When the descending current spreads over the entire thundercloud, the thundercloud enters into its decay stage, precipitation soon stops and the cloud disappears. If there is a strong wind in the upper layer and the axis of the thundercloud is greatly tilted, the descending current having developed in the middle layer drifts out of the cloud on the leeward side and sometimes endures for hours without causing a descending current until the supply of heat that feeds the thundercloud ends.

In any case, the altitude reached by the cloud top is about 18 km in the tropics but lower in Japan. So, it is unlikely to affect the airship which will stay 20 km high.

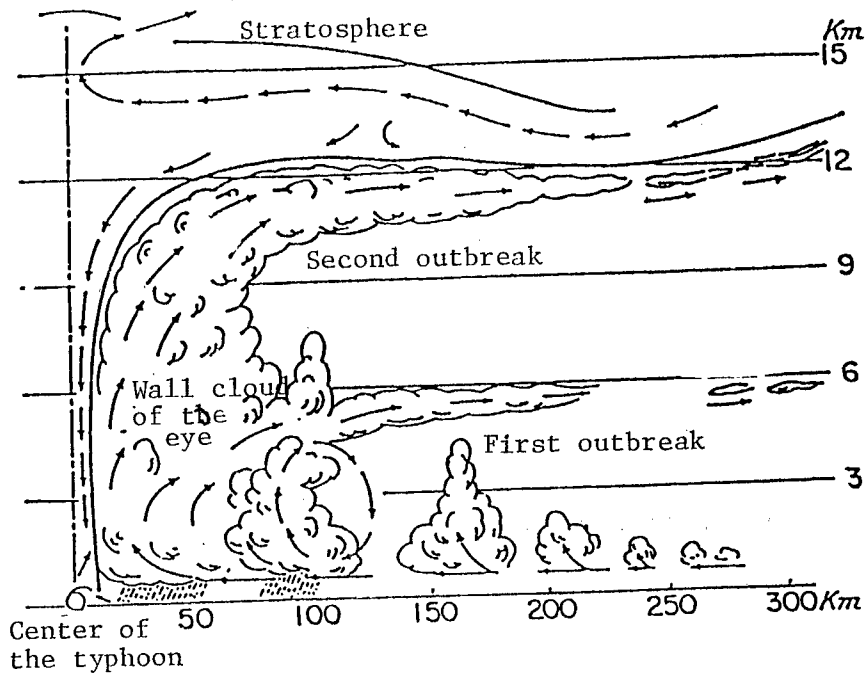

Figure 25. Solid Structure of Typhoon

(b) Typhoon

A typhoon is a tropical cyclone caused in the southern seas and accompanied by a rainstorm. Air pressure decreases sharply toward its center and wind speed increases as sharply. But at the center, wind suddenly falls. There, rain stops, and clouds break to show blue sky sometimes.

This is because all winds blowing toward the center of the typhoon become gradient winds (winds blowing toward the tangents of isobars) as they approach the center, the barometric gradient force (force that acts to move air from the high pressure part to the low pressure part) of the field and the centrifugal force by the revolution of air become balanced and the air current ceases to blow into the center. So, the air current ascends as it circles around the eye, reaches the top of the troposphere soon and diverges all round. Figure 25 shows the solid structure of a typhoon.

It is considered from the above that the effects of typhoon winds are generally limited within the bounds of the troposphere and that the winds do not affect the airship staying in the stratosphere.

(3) Characteristics of the Stratospheric Airship

The stratospheric airship has the following advantages over other aircraft and artificial satellites:

a. It can stay at a medium altitude.

As indicated in Figure 26, it can stay at an altitude intermediate between the artificial satellite and aircraft in general.

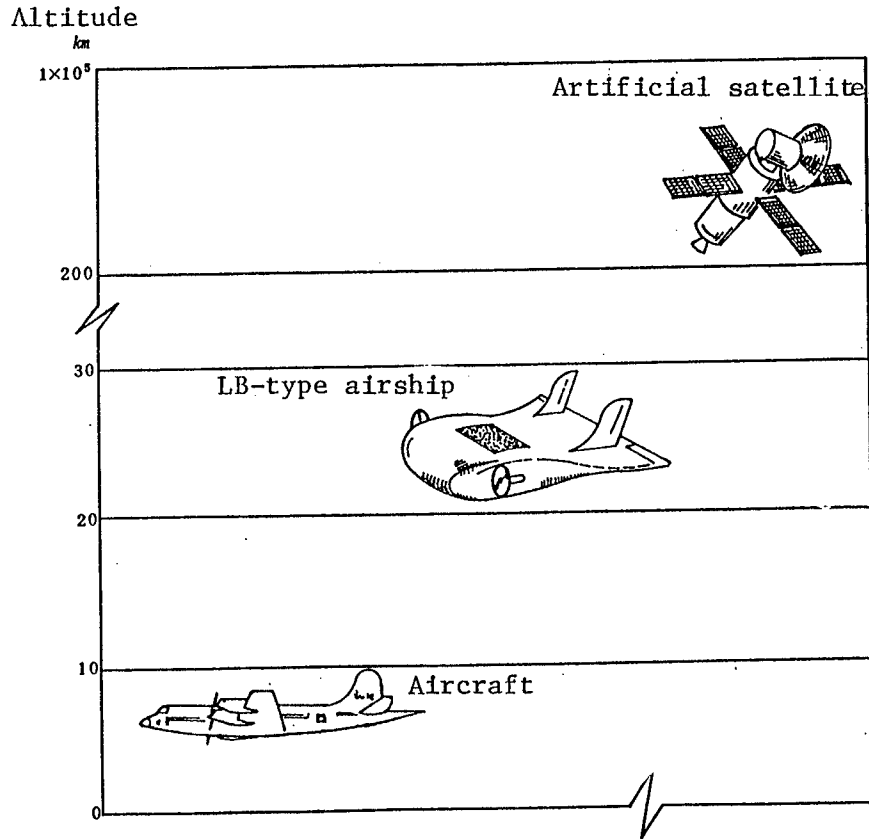

Figure 26. Comparison of Operating Altitudes of Aircraft, Stratosphere-Staying Airship and Artificial Satellite

b. It can remain buoyant for long hours.

The buoyancy of this airship is due to helium gas contained in the ship and the lift due to cruising. Its propelling power is supplied by both a solar cell and a regenerative fuel cell, thereby enabling it to stay for a long period.

c. It is economical.

It can be designed more easily than other aircraft because of its simple structure and its character of not flying at a high speed. Its operating cost is estimated at one-third and one-fifth, compared with, respectively, the fixed wing aircraft and the helicopter. Further, it does not involve the difficulty of recovery, as does the artificial satellite. It can be readily recovered and returned if malfunctioning.

d. It is virtually nonpolluting.

This airship normally operates at great altitudes but since it has a powered takeoff, the possibility of environmental pollution needs to be studied. It is propelled by slow-turning propellers driven by electric motors. So it causes only a small amount of noise and discharges no exhausts to pollute the stratosphere.

e. It requires only relatively small ground facilities.

The main ground facilities required to operate this airship are a runway and a hangar. Its V/STOL character makes the long aircraft runway unnecessary. Unlike the conventional (spindle-shaped) airship, this airship can be kept in an existing hangar. The LB type airship measures 75-m long, 42-m wide, and 18-m high, thus nearly equalling 70.5-m, 59.6-m, and 19.3-m for the Boeing 747.

f. It is very safe.

Since noncombustible helium gas, rather than combustible hydrogen gas as in the past, is used, this airship is in no danger of explosion. If a hole somehow develops in a part of the ship, there is no fear of a sudden fall since the ship holds a number of helium-containing bags. Further, it can easily avoid residential areas in landing through ground guidance because it is equipped for power.

g. It permits unmanned remote control.

Balloons in general are completely at the mercy of wind but this airship can be remote-controlled from a ground station because it is provided with power and with an elevator, etc.

h. It does not obstruct the navigation of civil aircraft.

Since this airship flies at the great altitude of 20,000 m, it never interferes with the flying routes at an altitude of about 10,000 m that civil aircraft often use.

i. A few such airships can handle simultaneous and sustained observation for the entire territory.

As will be later discussed in detail, at a great altitude the range of observation expands so much with the aid of radar, infrared camera, etc., that all of Japan can come under observation by only a few stratosphere-stationed airships. Unlike the United States which can make effective use of many reconnaissance satellites, Japan with its severe restriction on the use of artificial satellites for defense purposes will find these airships economical and effective as a means of early warning.

(4) Invulnerability of the Stratospheric Airship

If an ultrahigh (20-30 km) flying airship is to be attacked, it is by a military satellite or an aircraft. The means by which a military satellite attacks an airship is either a laser weapon or direct hit by an intercepting satellite. However, laser emitted against an airship from a military satellite (the approach point is 200-km even with a reconnaissance satellite which can come closest) is considered to be ineffective due to thick air because the airship stays in the stratosphere. Also, if an attempt is made to destroy the airship directly by an intercepting satellite with its changed orbit, the satellite seems likely to burn out as it enters the stratum. Even if it escapes burning, it cannot easily destroy the airship with pinpoint accuracy.

In an attack by a missile-carrying aircraft, meanwhile, the aircraft itself will have to climb to a considerable height and cannot surprise the airship which has a look-down capacity. If an attempt to attack is foreseen early enough, it will be possible to take such evasive actions as causing the airship to jettison its fuel cell and make a rapid climb by an instruction from the ground station.

As seen above, an airship designed for prolonged stay in the stratosphere is protected against surprise and unexpectedly invulnerable in spite of its vulnerable appearance. Figure 27 is a conceptual diagram of the invulnerability of this airship.

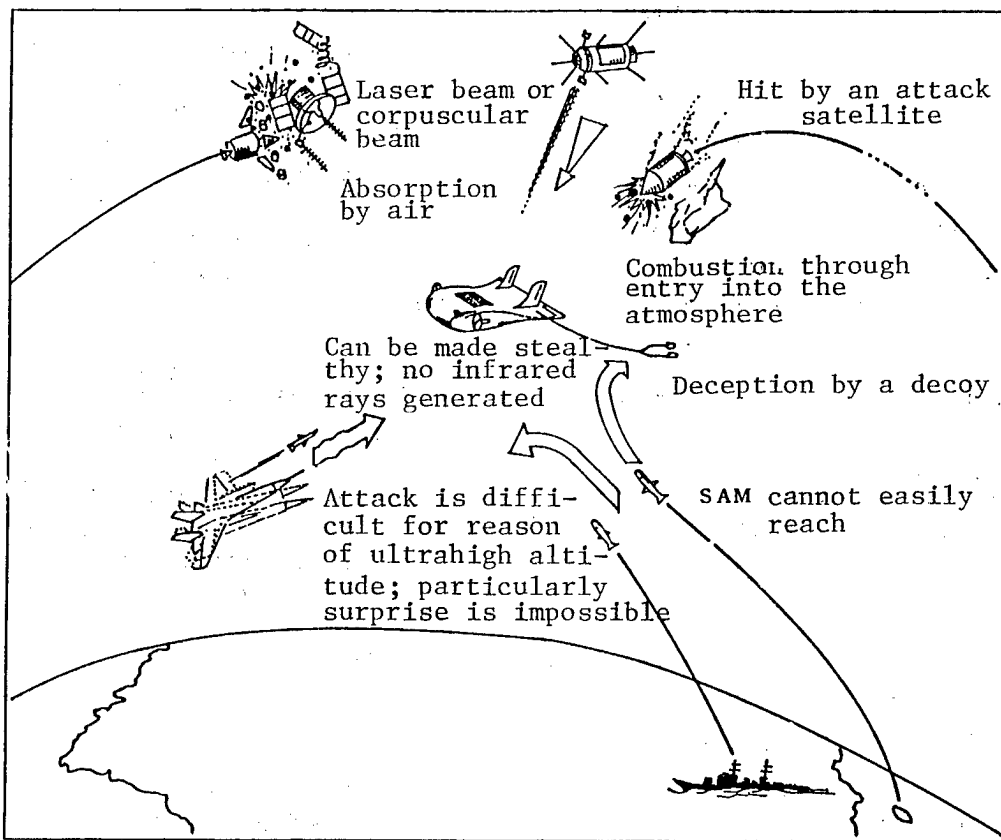

Figure 27. Conceptual Drawing of Invulnerability of Stratospheric Airship

(5) Examples of Defense Use of the Stratospheric Airship

a. Early warning

Latest aircraft not only have excellent flying capacity and improved capacities of onboard electronic equipment, such as radar and electronic warfare devices, due to the rapid advance of aeronautical technology but also the vastly improved combat capacities due to the development of long-distance, high-precision air-to-air missiles, and air-to-ground missiles. Ground radar sites, which are eyes and ears in air defense operations and handle air interception control, are certain to be attacked first and will be attacked with missiles from a long distance after low-altitude infiltration accompanied by jamming.

Japan has an air defense radar network composed of 28 fixed radar sites all around the Japanese islands and always on the lookout early to detect invading aircraft. However, low-flying invader planes are difficult to detect early because of the characteristics of radar and curvatures on the surface of the earth. A definite example of this is the MIG-25 affair which occurred in September 1976 and was an acute reminder of the clear limits to the role of ground radar sites. To supplement the functions of ground radar sites, mobile three-dimensional radar equipment and nine E-2C early warning planes capable of early detecting low-flying invader planes will be bought by the time of completion of work under the 1986 Intermediate Term Operations Estimates.

E-2C is an excellent early warning plane and its characteristics are mainly as follows: 1) It can fly as far out of the mainland as possible and make prolonged (4.5-hour) patrol; thus, it can give all the more time for interception. 2) It can range from low to ultrahigh altitudes and is capable of detecting and identifying from a long distance (capable of monitoring cylindrical space of SL~10,000 feet in altitude and radius of at least 200 nautical miles in distance) and, moreover, capable of complete detection and tracking (transmitting data to 300 targets and 45 friendly interceptors). 3) It can function at defense command.

Unlike the ground radar site, the one early warning flying unit proposed by the general defense plan may have difficulty maintaining lookout all around Japan at all times. It is, therefore, considered that incorporating airships with a look-down capacity and continuous monitoring capacity into the early warning system will contribute to the improvement of the early warning capacity and the strengthening of the system. The airships will carry remote sensing systems including radar infrared sensors and perform early warning duties by linking data gained to ground stations and aircraft, etc.

Table 10 compares various early warning systems.

b. Antisubmarine patrolling

Perhaps, the greatest threat to defense today is the nuclear-powered submarine carrying ballistic missiles and operating deep undersea.

Table 10. Comparison of Early Warning Systems

		Ground radar sites	Early warning planes	Subject airships
All-weather navigability		Excellent	Good	Excellent
Ability to detect low-flying invader planes		Inferior	Excellent	Excellent
Invulnerability		Inferior	Excellent	Good
Operating time		Excellent	Good	Excellent
Radar system	Clutter elimination	Excellent	Good	Excellent
	Reliability	Excellent	Excellent	Good
	Power	Excellent	Excellent	Good
Economy		Good	Inferior	Good

The submarine in World War I used batteries to cruise underwater and navigated the sea surface most of the time. Antisubmarine actions consisted merely of visual patrolling and attack. But now is the time of nuclear-powered submarines capable of long submerged cruises, great-depth submerging, quietness, and offensive power. To cope with them, aircraft and naval vessels carry various sensors and actions are initiated by the procedure of search and detection, identification, measurement for attack data, attack.

At present, fixed-wing planes (examples: P-3C and PS-1), helicopters, submarines, surface ships and military satellites (which Japan lacks) are used as platforms. As means of detection, sonars and sonobuoys taking advantage of underwater sounds and also radars, magnetic detectors, infrared sensors, etc., are used to detect submarines by observing their pump, screw, and other underwater navigating sounds, the disturbance of sea water in the case of shallow depths, warm effluents from nuclear-powered submarines and the disturbance of the earth's magnetic field. Besides, there are underwater fixed sonars and the Americans transmit data thus gained to their homeland via military satellites.

In the Japanese antisubmarine patrolling of today, platforms capable of extensive and continuous observation are nonexistent. It is, therefore, considered that if the subject airship, which can perform these functions, is used as an antisubmarine weapon by equipping it with a radar and infrared sensors, it may well prove to be effective. But unlike P-3C, it cannot attack or make pinpoint search. So, it must cooperate with other aircraft and naval vessels by data linking. Namely, effective operation can be achieved by using the airship to generally assess the movements of the invading submarine and enabling aircraft, to locate the submarine exactly.

When using sonobuoys, they are first scattered from a fast aircraft and signals from them are relayed by the airship; then an attack is mounted by

intercepting aircraft. In this manner, not only the time to detect and attack can be saved but also the workload of the crews of patrol planes making prolonged flights will be reduced.

c. Communications relay

Raising the level of each individual weapon does not significantly contribute to the buildup of combat capabilities. Rather, it is strategically and tactically very important how effective the cooperation between friendly aircraft or naval vessels can be. Today, the C³ system, or the system of joint command communications, is central to modern warfare. C³ stands for command, control and communication and "C³I" is sometimes used as C³ plus intelligence. C³ is a large military electronic system encompassing reconnaissance, intelligence analysis, command, the grasp of tactical situations, the control of strength and communications. If the missile, the tank and the like are muscles in the human body, C³ is the brain and the nervous system.

As Japanese command and control systems, there are the central command system, the fleet command support system and the BADGE system. And as communications systems, there are the fixed communications system linking camps, bases, and other facilities together and the mobile communications system linking field units, naval vessels, and aircraft together.

Both the United States and the Soviet Union operate military satellites with a view to the invulnerability of their communications networks, long-distance communications, and the increase of communication volume in an emergency.

It seems that, to strengthen the Japanese C³ system furthermore, the airship, which can handle long-distance communications, may be effectively used for a communications network. It is possible to make the subject airship function as a relay in command, communications, etc., by equipping it with a nondirectional antenna, a transmitter-receiver, and other items.

(6) Summary

Perhaps, military satellites or similar platforms for maintaining extensive and continuous security observation are among the equipment that is now most necessary for the defense of Japan. The proposed airship for prolonged stay in the stratosphere could substitute the military satellite in executing this mission and conforms to the Japanese principle of "defense only."

BIBLIOGRAPHY

1. Tanaka, Shinzo, "Airship Age," ASAHI SONORAMA, 1974.
2. Ibid., "Miscellany on the Airship," Graph Co., 1983.
3. Iinuma, Kazumasa, "Rediscovery of the Airship," Blue (Back), 384, Kodansha, 1979.

4. Azuma, (Akira), "Future of the Airship," JOURNAL OF THE JAPANESE SOCIETY OF AERONAUTICS AND SPACE SCIENCE, Vol 24 No 207, 1976.
5. "Investigation and Research Concerning LTA Aircraft System," Kikai Shinko Kyokai (foundation), September 1975.
6. "Second Investigation Concerning LTA Aircraft System," Kikai Shinko Kyokai (foundation), September 1976.
7. "Technology Assessment of LTA Aircraft System," Nippon Sangyo Gijutsu Shinko Kyokai (foundation), March 1978.
8. Azuma, (Akira), "About Two New Airships," BUOYANT KOKU (AVIATION), Vol 10 No 1, 1983, Buoyant Koku Kondankai.
9. "Study of Balloon-Carried Communications Relay System (Part 1)," First Team Attached to Technical Development Official (Aircraft), Technical Research and Development Institute, Defense Agency, January 1980.
10. Ardema, M.D., "Vehicle Concepts and Technology Requirements for Buoyant Heavy-Lift Systems," NASA Technical Paper 1921, 1981.
11. Miller, W. McE., Jr., Putman, W.F., and Havill, C.D., "The Lifting-Body-Airship: A Future Delivery System for Remote Area Logistics," Canadian Aeronautics and Space Journal, Vol 22 No 1, 1976
12. "FY 1983 Research Report on Airship System," Japanese Association of Aeronautical and Space Industry, August 1984.
13. Vorachek, Jerome J., "Investigation of Powered Lighter-Than-Air Vehicles," Goodyear Aerospace Corp., AFCRL-68-9626, AD680829, 1968.
14. Marcy, W.L., "Propulsion Options for the HI Spot Long Endurance Drone Airship," Martin Marietta Corp. AD074595, 1979.
15. Ardema, M.D. and Flaig, K., "Parametric Study of Modern Air Ship Productivity," NASA TM-81151, 1980.
16. Schneider, J.J., "Future Lighter-Than-Air Concepts," Air Transportation Meeting, Hartford, Conn., 6-8 May 1975.

20,108/9365
 CSO: 4306/2524

NUCLEAR DEVELOPMENT

STATUS OF LASER ENRICHMENT TECHNOLOGY UPDATED

Tokyo PUROMETEUSU in Japanese Nov 85 pp 41-43

[Article by Yasushi Sakabe, Nuclear Fuel Division, Atomic Energy Bureau, Science and Technology Agency]

[Text] As can be seen in the start of construction of a prototype plant by the Power Reactor and Nuclear Fuel Development Corporation and in the finalization of plans for the construction of a commercial plant by the Japan Nuclear Fuel Service Co., uranium enrichment in Japan is entering a stage of commercialization.

As for the world-wide supply and demand for enriched uranium, it is believed that the surplus in uranium will continue for some time to come, and consequently the demand for reduced enrichment costs is becoming more acute in all countries. It is easy to understand the U.S. Department of Energy's decision in June of this year to adopt an atomic laser method as the country's next generation of enrichment technology, in view of the enriched uranium situation.

Research into laser enrichment technology in Japan has until now been promoted mainly by the Japan Atomic Energy Research Institute and the Institute of Physical and Chemical Research, the former in the field of the atomic laser method and the latter in the particle laser method. There is increased momentum in Japan to accelerate research and development of uranium enrichment technology using lasers. This technology is expected to become more economical in the future, and it is felt that Japan should realize its commercial application at an early time.

Research in laser enrichment technology in Japan, however, is said to be about 10 years behind the United States, the leader in the field, and there are many technical tasks which need solutions before the technology can be put to practical use. This technology is an agglomeration of a wide spectrum of technology, including laser technology, high temperature and high vacuum technology. Research needs to be promoted with close cooperation between industry, academia and government.

Described below are the principles of uranium enrichment by a laser method, the technology's current status and future prospects, centered on research and development activity at the Japan Atomic Energy Research Institute and the Institute of Physical and Chemical Research.

Principles of uranium enrichment by laser

1. Atomic laser method

Uranium-235 and uranium-238 have slightly different levels of electron energy. In this method, the difference is taken advantage of to separate uranium-235 by using laser light with a wavelength that specifically absorbs only uranium-235. The method is made up of the following processes:

- (1) Evaporation process: By heating metal uranium to a temperature of about 3000 K and allowing it to evaporate, a flow of uranium atoms is created.
- (2) Selective excitation process: A flow of uranium atoms is irradiated with laser light of a specific wavelength so as to excite only uranium-235.
- (3) Ionization process: The selectively excited U-235 is further irradiated with laser light of a specific wavelength for intermediate excitation and ionization, to ionize it.
- (4) Recovery process: The uranium vapor produced in the wake of laser light irradiation is led to an electric field, where ionized U-235 is attracted to an electrode for recovery while uranium atoms (mainly uranium-238) not ionized, are collected in a recovery chamber.

Figure 1 shows the principles of uranium enrichment using the atomic laser method.

2. Particle laser method

UF₆ is a strong absorber of infrared rays of 16 microns. ²³⁵UF₆ and ²³⁸UF₆, however, absorb infrared rays of slightly different wavelengths, and the difference is utilized to separate ²³⁵U in the form of ²³⁵UF₅ (powder) for recovery. The work involves the following processes:

- (1) Cooling process: UF₆ gas is jetted through a nozzle into a vacuum to cool by adiabatic expansion to a temperature of about minus 200 degrees C and to clarify the shifting of isotopes in the absorption spectrum.
- (2) Selective excitation, and dissociation process: The UF₆, after cooling, is irradiated by a fine-controlled infrared laser to selectively excite ²³⁵UF₆ particles. It is further irradiated with a more powerful infrared laser. The ²³⁵UF₆ particles, after several energy level changes, go into a state of dissociation to produce ²³⁵UF₅.
- (3) Separation and collection process: After dissociation, the ²³⁵UF₅ takes the form of impalpable powder, so the particles can be separated for collection. Figure 2 shows the principles of the particle laser method.

図1 原子レーザー法ウラン濃縮プロセス概念図

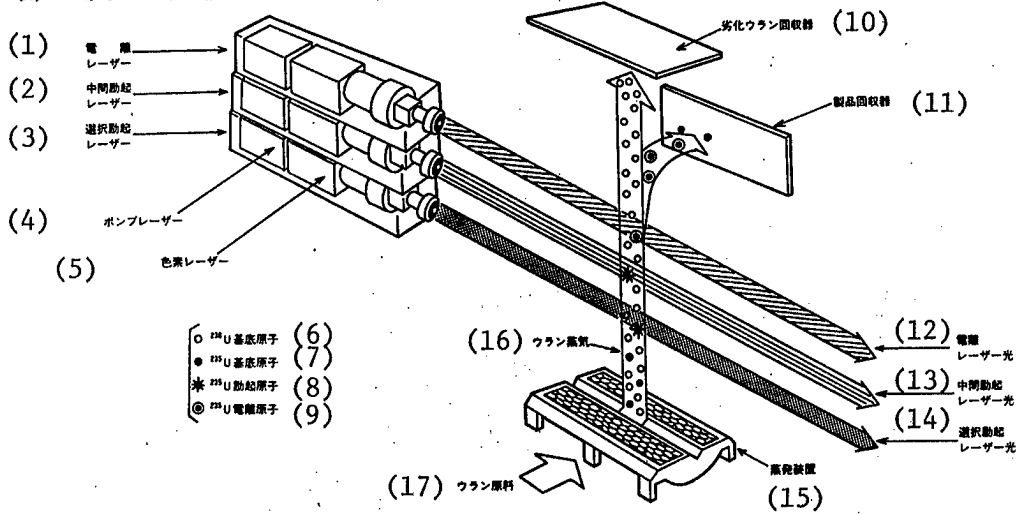

Figure 1. Schematic Diagram of Uranium Enrichment by Atomic Laser Method

Key:

1. Ionization laser
2. Intermediate excitation laser
3. Selective excitation laser
4. Pump laser
5. Pigment laser
6. ^{238}U base atom
7. ^{235}U base atom
8. ^{235}U excited atom
9. ^{235}U ionized atom
10. Depleted uranium recovery device
11. Produce recovery device
12. Ionized laser light
13. Intermediate excited laser light
14. Selective excited laser light
15. Vaporizing device
16. Uranium vapor
17. Uranium raw material

図2 分子レーザー法ウラン濃縮プロセス概念図

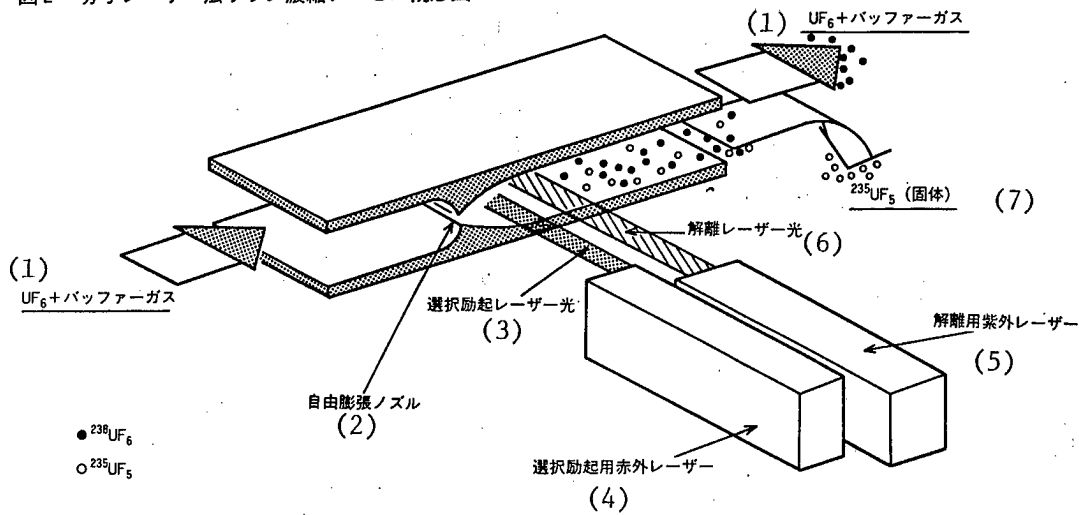

Figure 2. Schematic Diagram of Uranium Enrichment Process by Particle Laser Method

Key:

1. UF_6 + buffer gas
2. Free expansion nozzle
3. Selectively excited laser light
4. Infrared laser for selective excitation
5. Infrared laser for dissociation
6. Dissociated laser light
7. Solid

Features of uranium enrichment by laser method

1. Comparing the laser method with the conventional centrifuge method and gaseous diffusion method

Compared with the conventional processes, the laser uranium enrichment process has the following advantages:

(1) Since only ^{235}U and $^{235}UF_6$ are selectively made to change their qualitative properties before separation, the laser uranium enrichment method has a large separation coefficient, and yet requires a very small amount of energy in the separation process itself.

(2) Thanks to its large separation coefficient, the laser method has little need for a cascade system in which identical machines are linked together in succession, a requirement with the conventional enrichment methods. Therefore, the plant can be small and compact.

(3) Thanks to its large separation coefficient, the laser method can be used for enrichment of the depleted uranium that has been produced as a by-product of the conventional enrichment methods.

(4) Lasers themselves are a new and evolving high technology, and are expected to have great ripple effects on research in many other science and technology fields. Table 1 shows a comparison of various enrichment methods.

表1 ウラン濃縮技術の比較

(6) 項目 \ (1) 方法	(2) ガス拡散法 (GD)	(3) 遠心分離法 (GC)	(4) 原子レーザー法 (AVLIS)	(5) 分子レーザー法 (MLIS)
(7) 作業物質	UF ₆	UF ₆	U	UF ₆
(8) 分離係数	小 (11)	中 (12)	大 (13)	大 (13)
(9) 分離段数	大 (13)	中 (12)	小 (11)	小 (11)
(10) 電力消費量 (kWh/kgSWU)	大 (13)	小 (11)	小 (11)	小 (11)

Table 1. Comparing Uranium Enrichment Technologies

Key:

1. Method
2. Gaseous diffusion process
3. Centrifuge process
4. Atomic laser process
5. Particle laser process
6. Item
7. Working material
8. Separation coefficient
9. Separation stages
10. Power consumption
11. Small
12. Medium
13. Large

2. Comparing the atomic laser method with the particle laser method

The greatest features of the atomic laser method are its extremely large separation coefficient and the fact that it is far ahead of the particle laser method in terms of research and development. The particle laser method, on the other hand, has the advantage of employing the familiar technique of processing UF₆, thus making it resemble more closely an ordinary chemical plant.

Both methods have advantages and disadvantages, and their technical evaluation will be possible after further research and development and after evaluating field data.

Present status and tasks of the laser-based uranium enrichment technology

1. Atomic laser method

The Japan Atomic Energy Research Institute started basic research on laser enrichment technology in 1974, and in the principle demonstration tests conducted from FY 1976 to FY 1983, the institute confirmed the technology's high separation capability as expected and succeeded in the recovery of 88 micrograms of low-level enriched uranium.

On the strength of its achievements, the institute has begun engineering tests in a six-year program from FY 1984 to FY 1989. Research and development are now in progress.

The system based on atomic laser technology is made up of a laser system and a vacuum vessel (separation chamber) where uranium is enriched by generating and/or recovery uranium vapor.

The ultimate objective of this testing is to build up a system by combining various components and confirm its separation capability on the order of several kilograms SWU per year. As a precondition to the project, however, solutions need to be found to the problems associated with the components.

In the development of the copper vapor laser, which forms the core of the system, the problems are how to increase its output and its life.

In the development of the separation chamber, aside from the need to establish as soon as possible an engineering image of the entire chamber, there are many problems awaiting solutions. They include drafting designs of various components, including the uranium vapor generating system, laser irradiation device and uranium recovery device, heat designs of various chamber components, and development of a uranium alloy with high evaporation characteristics.

In the development of the copper vapor laser, the prospects are beginning to brighten, thanks to the efforts of the makers, but in the latter case, development of the separation chamber, much research and development will be needed for years to come.

2. Particle laser method

The Institute of Physical and Chemical Research has long been engaged in the research and development of lasers, and the development of a Raman laser suitable for the particle laser process is one of its achievements. The institute began research on a method for separation of isotopes using a laser as early as 1976. Under a 3-year project beginning in 1986, the institute has begun a test to demonstrate the principle of uranium enrichment based on the particle laser process and has already confirmed enrichment of uranium, albeit in small quantity.

The main objective of this testing is to manufacture, on trial, a system based on the particle laser process and confirm its separation capability on the order of several grams SWU/year. Among the tasks which need to be solved

before the system's element technologies can be developed are an increase in the number of repetitive oscillations of CO₂ laser, development of a nozzle with excellent cooling and light-absorbing characteristics, and development of a continuous supply and recovery system of UF₆ gas.

* * *

The tempo of construction of light water reactors in Japan has slowed, and the existing power plants have been running at a high operating rate. Prices of fossil fuels, on the other hand, have been shifting on a stable basis, and as a consequence nuclear power generation, it is reported, has lost some of the absolute superiority in economics that it once enjoyed over other means of power generation. Given such a situation, in the future the emphasis in new uranium enrichment technology will be placed more on reduction of the cost of enriched uranium than on the volume of enriched uranium. The effort in the development of the laser methods is considered part of that drive.

Japan has a long history of development of enriched uranium technology based on the centrifuge process. The results are about to bear a fruit, in the form of the beginning of operations in a commercial plant, scheduled for 1986. Depending on efforts, the centrifuge process has much room for improvement in its economics, and thus great expectations are placed on it. The laser process, on the other hand, has just marked its first step, so it needs to be fostered with the combined efforts of the government, academia and industry.

20114/9716
CSO: 4306/2540

NUCLEAR DEVELOPMENT

INTERIM REPORT ON HIGH TEMPERATURE GAS REACTOR DEVELOPMENT

Tokyo GENSHIRYOKU SANGYO SHIMBUN in Japanese 1 May 86 p 1

[Text] On 24 April the Nuclear Energy Commission convened the first meeting of the High Temperature Gas Reactor Research/Development Planning Council (chairman: Ryoseki Mishima, professor emeritus, Tokyo University) to deliberate the future course of high temperature gas furnace development with a view to reporting in November. While cost estimates for the heat used by consumers--with respect to such future technology as nuclear powered iron manufacturing--is stagnating, the debate will center around how high temperature gas furnaces can be developed and inducted into non-electrical sectors which comprises 70 percent of Japan's total energy consumption and how a stable supply of energy can be established.

The said Council was established by the Nuclear Energy Commission on 18 March with the purpose of deliberating 1. the significance of research development of a high temperature gas furnace; 2. evaluation of research development up to now and 3. the future course of research development.

In a statement made at the Council's initial meeting, the representative of the Nuclear Energy Commission Chief--Noboru Mukoabo--said: "Now that we have established the light water furnace, we must think about developing a heat efficient plant as a future direction. This includes high temperature heat utilization, smaller and simpler plant models and so on." He pointed out the need for more sophisticated and diversified nuclear energy development.

Currently in Japan, the Nuclear Energy Research Institute is in the final phase of working out detailed designs for a test furnace (furnace core opening helium temperature--950 C, heat output--50,000 kw). The plan calls for construction to begin as early as 1987.

The basic thinking in the various industries regarding actual utilization is as follows: The electric power sector holds that high temperature gas furnace power generation is unthinkable. The iron manufacturing industry is of the opinion that in the 21st century there is a possibility of obtaining cheap recycled gas. Half the chemical sector thinks that it can be inducted into methanol production, ethylene dehydrogenation processing and the other half believes that the chemical industry as a whole ought to aim toward biotechnology and the exact sciences. There is no uniformity of opinion as yet.

The next meeting of the Council is scheduled for 26 May. It will deliberate the civilian thinking regarding this matter compiled by the Japan Nuclear Energy Industry Council and consider arguments from the users' perspective as well. Thereafter the meetings will be called once a month and an interim report focusing on the budget for FY 1987 will be compiled by the end of August.

11460/12781
CSO: 4306/2078

END